

INTAKE AIR CONTROL VALVE

COMPONENTS

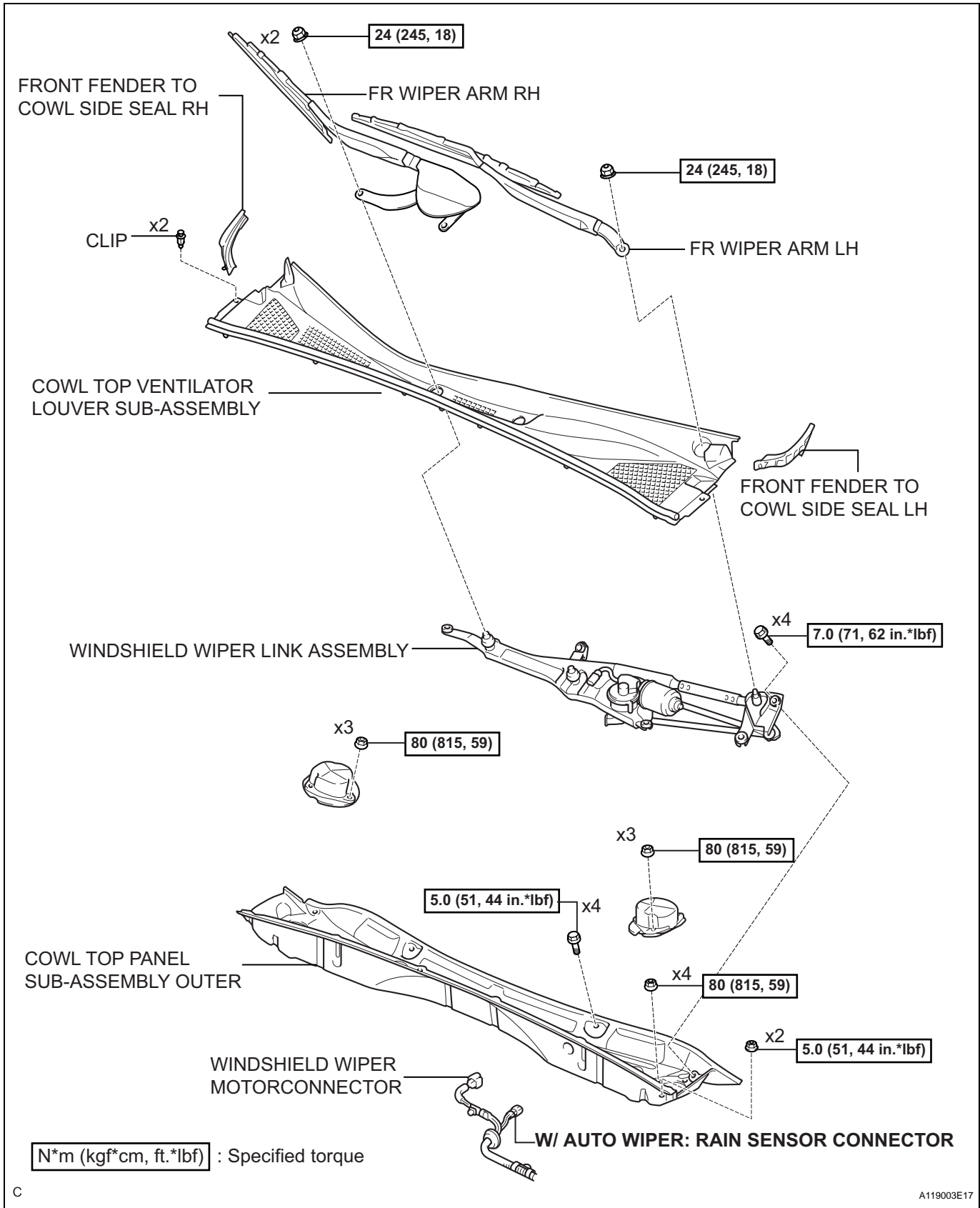

IT

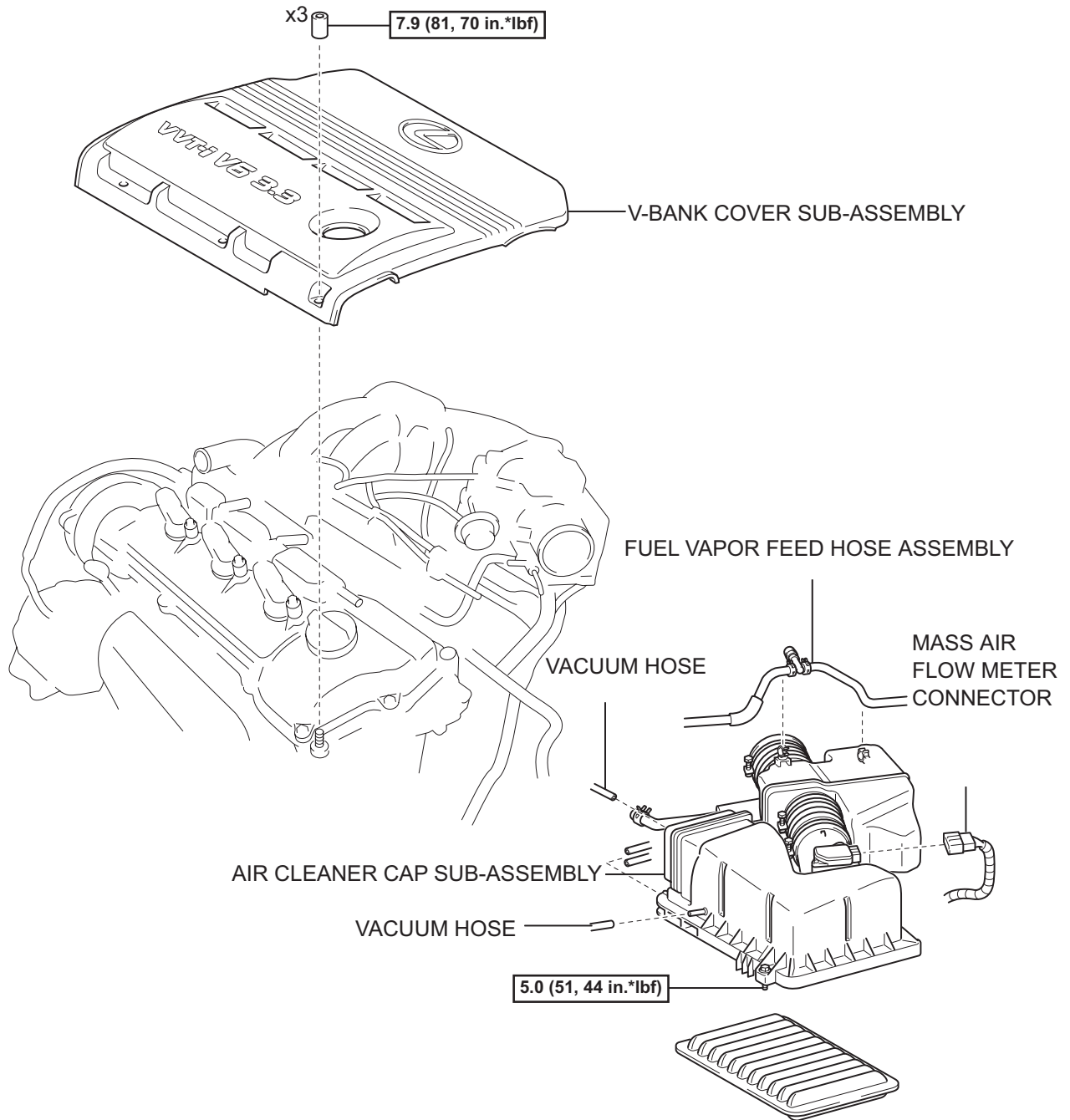

IT

N*m (kgf*cm, ft.*lbf) : Specified torque

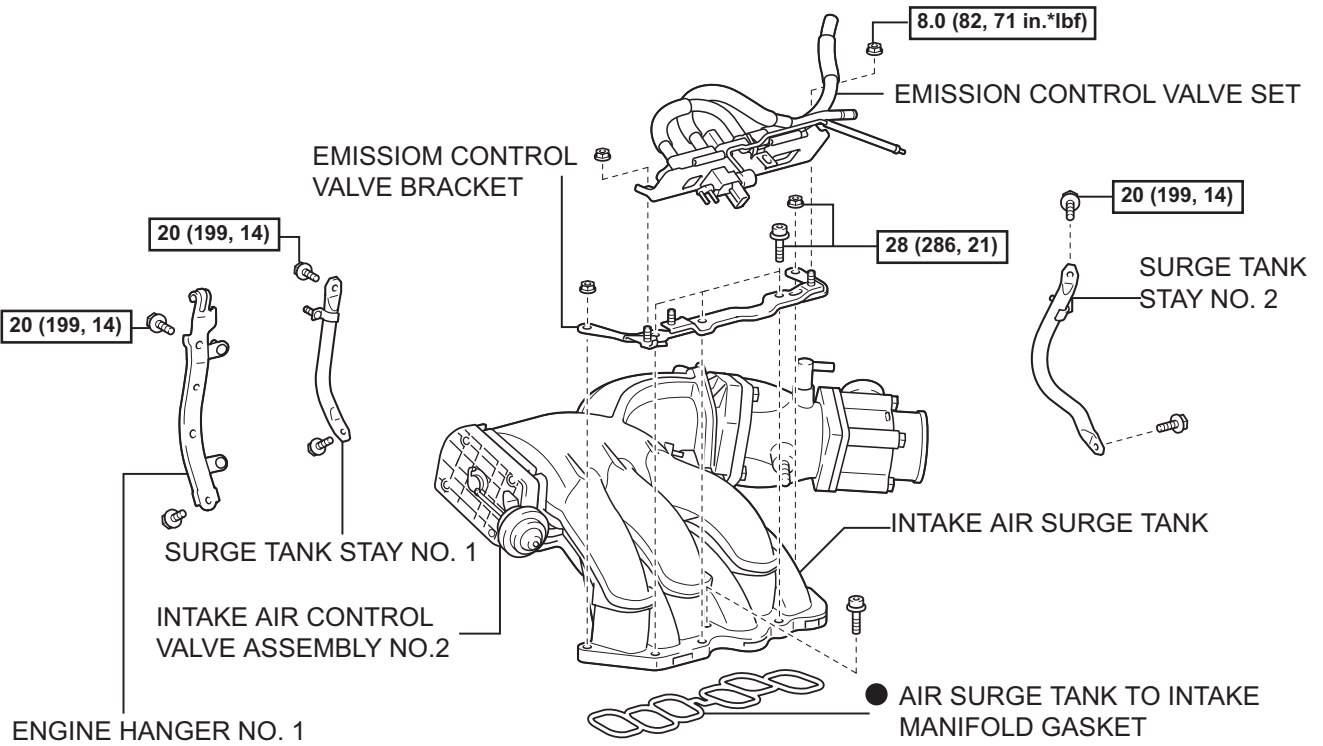

N*m (kgf*cm, ft.*lbf) : Specified torque

● Non-reusable part

IT