

## INSTALLATION

1. INSTALL LH HEADLIGHT ASSEMBLY
2. INSTALL FRONT BUMPER COVER (See page [ET-3](#))
3. INSTALL FRONT FENDER SPLASH SHIELD SUB-ASSEMBLY RH (See page [ET-4](#))
4. INSTALL FRONT FENDER SPLASH SHIELD SUB-ASSEMBLY LH (See page [ET-4](#))
5. INSTALL ENGINE UNDER COVER NO.1



## REPAIR

### 1. INSTALL HEADLIGHT PROTECTOR RETAINER UPPER

#### HINT:

- If the installation area of the headlight assembly is damaged, use the supply bracket for low-cost repair.
- Ensure that the headlight assembly is not damaged.

- (a) Cut off the part shaded in the illustration and sand smooth with sandpaper.

#### NOTICE:

**After cutting off the part, place the headlight protector retainer upper against the bosses and gradually file away until installation is possible.**

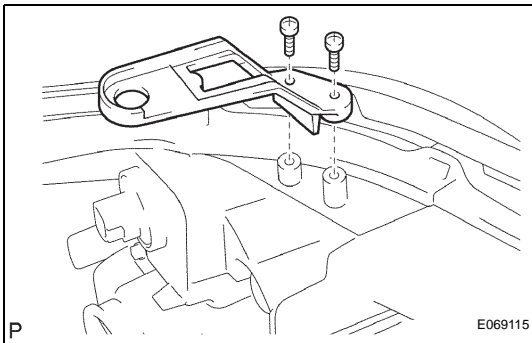
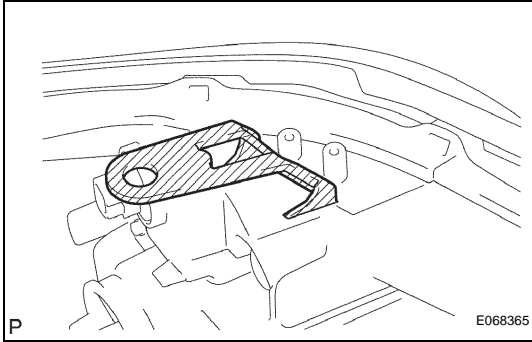

- (b) Install the headlight protector retainer upper with the 2 screws.

### 2. INSTALL HEADLIGHT PLATE

#### HINT:

- If the installation area of the headlight assembly is damaged, use the supply bracket for low-cost repair.
- Ensure that the headlight assembly is not damaged.

- (a) Cut off the part shaded in the illustration and sand smooth with sandpaper.

#### NOTICE:

**After cutting off the part, place the headlight plate against the bosses and gradually file away until installation is possible.**

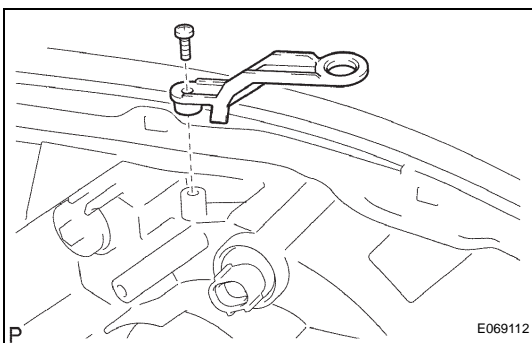
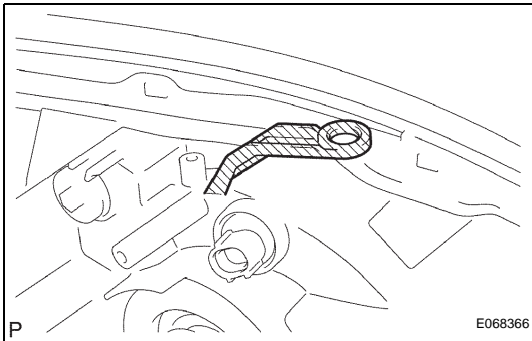

- (b) Install the headlight plate with the screw.

### 3. INSTALL HEADLIGHT PROTECTOR RETAINER LOWER

#### HINT:

- If the installation area of the headlight assembly is damaged, use the supply bracket for low-cost repair.
- Ensure that the headlight assembly is not damaged.

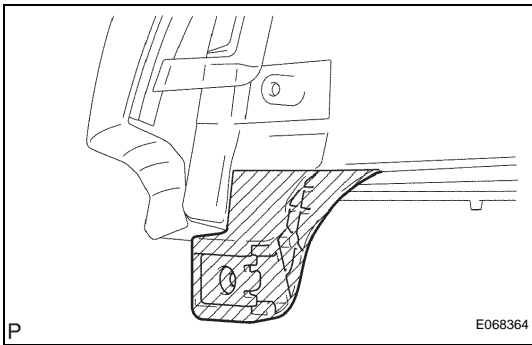

- (a) Cut off the part shaded in the illustration and sand smooth with sandpaper.

**NOTICE:**

**After cutting off the part, place the headlight protector retainer lower against the bosses and gradually file away until installation is possible.**

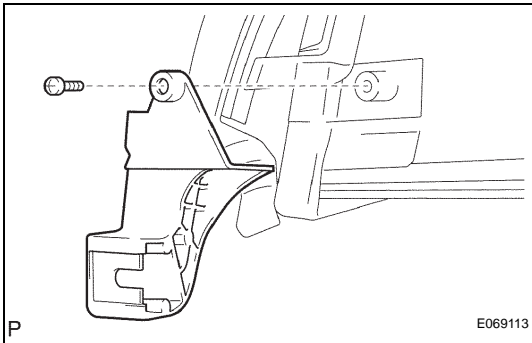

- (b) Install the headlight protector retainer lower with the screw.

**4. INSTALL HEADLIGHT BRACKET LOWER****HINT:**

- If the installation area of the headlight assembly is damaged, use the supply bracket for low-cost repair.
- Ensure that the headlight assembly is not damaged.

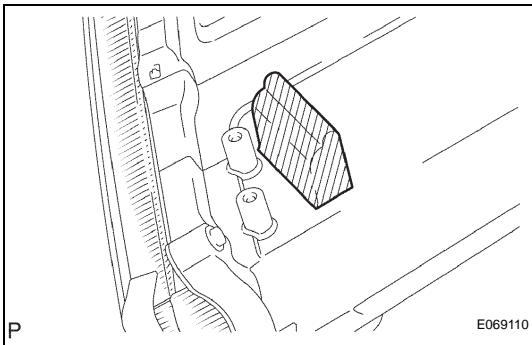

- (a) Cut off the part shaded in the illustration and sand smooth with sandpaper.

**NOTICE:**

**After cutting off the part, place the headlight bracket lower against the bosses and gradually file away until installation is possible.**

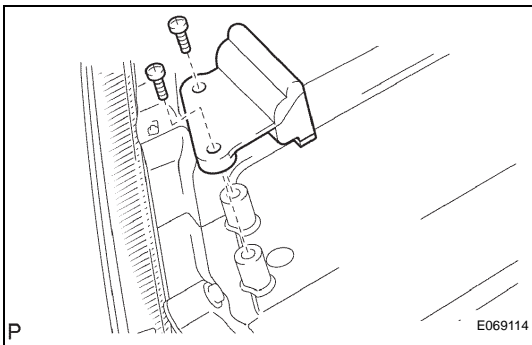

- (b) Install the headlight bracket lower with the 2 screws.