

DTC	B2410	Headlight Swivel ECU LH Communication Malfunction
DTC	B2411	Headlight Swivel ECU RH Communication Malfunction

DESCRIPTION

The headlight swivel ECU converts the signal from the AFS ECU to operate the headlight swivel motor, and receives the signal regarding the direction of the headlight and condition of the headlight swivel motor.

DTC No.	DTC Detecting Condition	Trouble Area
B2410	<ul style="list-style-type: none"> • Malfunction of headlight swivel ECU LH • Open or short in headlight swivel ECU LH circuit 	<ul style="list-style-type: none"> • Headlight swivel ECU LH • Harness or connector • AFS ECU
B2411	<ul style="list-style-type: none"> • Malfunction of headlight swivel ECU RH • Open or short in headlight swivel ECU RH circuit 	<ul style="list-style-type: none"> • Headlight swivel ECU RH • Harness or connector • AFS ECU

WIRING DIAGRAM

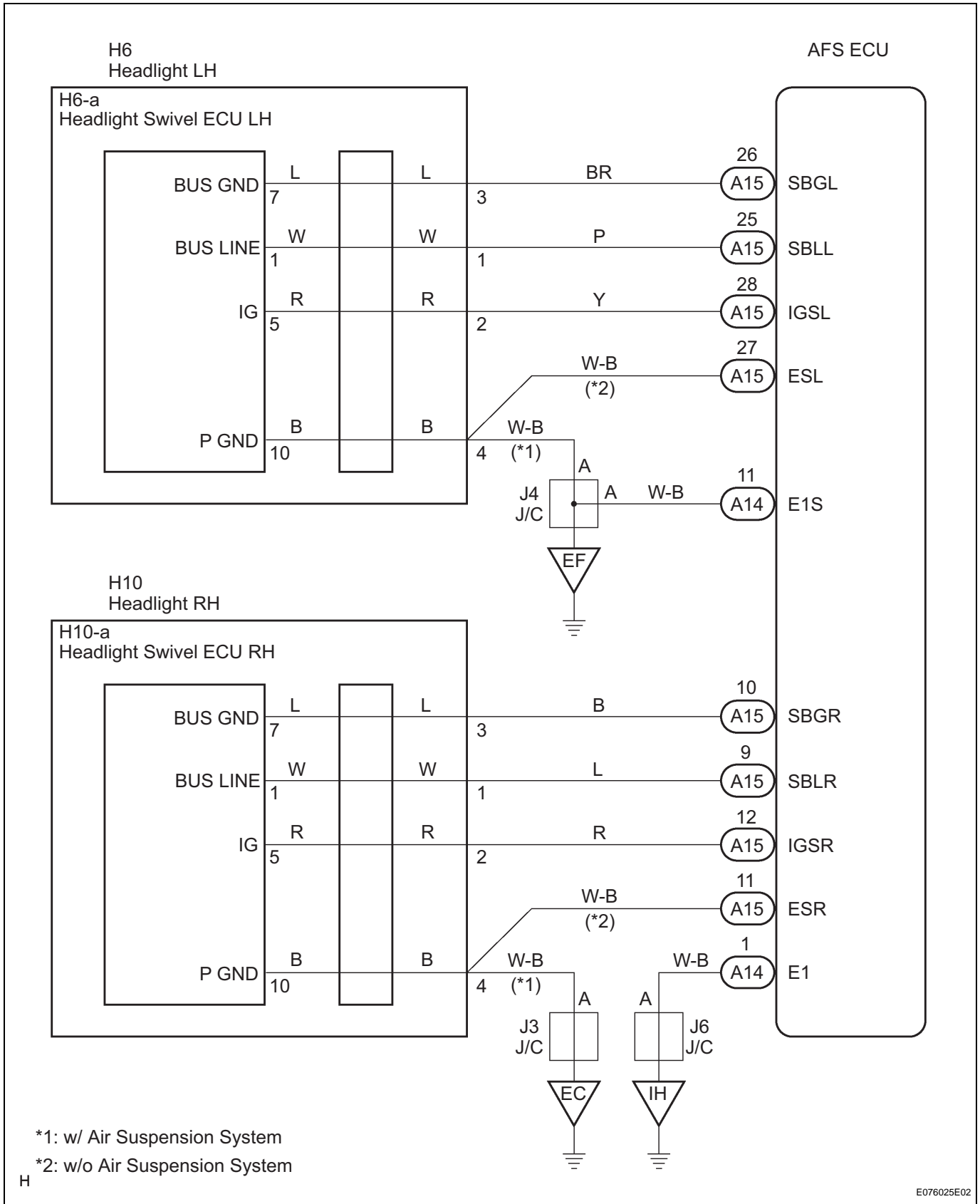

LI

1 CHECK VEHICLE CONDITION

(a) Check the vehicle condition.

Result

Condition	Proceed to
w/o Air Suspension System	A
w/ Air Suspension System	B

B → **Go to step 5**

A

2 CHECK HARNESS AND CONNECTOR (AFS ECU - HEADLIGHT SWIVEL ECU)

Wire Harness View:

- (H6)** Headlight LH
- (H10)** Headlight RH

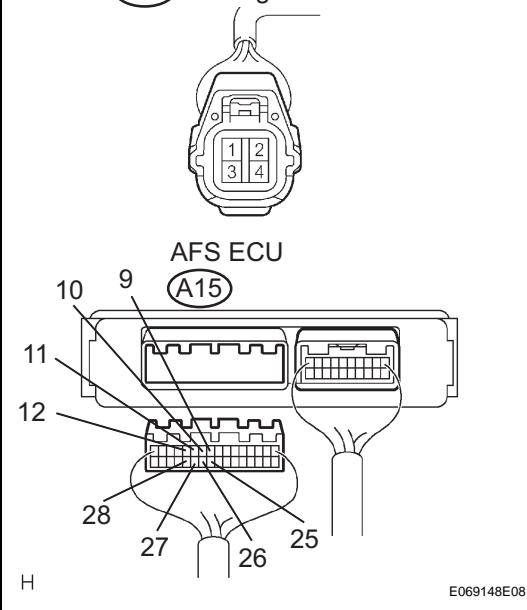

- (a) Disconnect the AFS ECU connector and headlight connector on the headlight swivel ECU side.
- (b) Measure the resistance according to the value(s) in the table below.

**Resistance:
LH Side (B2410)**

Tester connection	Condition	Specified condition
A15-25 (SBLL) - H6-1	Always	Below 1 Ω
A15-26 (SBGL) - H6-3	Always	Below 1 Ω
A15-28 (IGSL) - H6-2	Always	Below 1 Ω
A15-27 (ESL) - H6-4	Always	Below 1 Ω
A15-25 - Body ground	Always	10 kΩ or higher
A15-26 - Body ground	Always	10 kΩ or higher
A15-28 - Body ground	Always	10 kΩ or higher

RH Side (B2411)

Tester connection	Condition	Specified condition
A15-9 (SBLR) - H10-1	Always	Below 1 Ω
A15-10 (SBGR) - H10-3	Always	Below 1 Ω
A15-12 (IGSR) - H10-2	Always	Below 1 Ω
A15-11 (ESR) - H10-4	Always	Below 1 Ω

Tester connection	Condition	Specified condition
A15-9 - Body ground	Always	10 kΩ or higher
A15-10 - Body ground	Always	10 kΩ or higher
A15-12 - Body ground	Always	10 kΩ or higher

Connector Front View:

(H6) Headlight LH (H10) Headlight RH

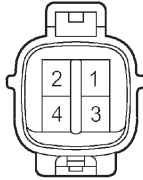

Wire Harness View:

(H6-a) Headlight Swivel ECU LH

(H10-a) Headlight Swivel ECU RH

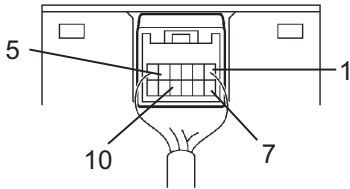

H

E069149E02

- (c) Disconnect the headlight connector on the headlight swivel ECU side and the headlight swivel ECU connector.
- (d) Measure the resistance according to the value(s) in the table below.

Resistance:

LH Side (B2410)

Tester connection	Condition	Specified condition
H6-1 - H6-a-1 (BUS LINE)	Always	Below 1 Ω
H6-2 - H6-a-5 (IG)	Always	Below 1 Ω
H6-3 - H6-a-7 (BUS GND)	Always	Below 1 Ω
H6-4 - H6-a-10 (P GND)	Always	Below 1 Ω

RH Side (B2411)

Tester connection	Condition	Specified condition
H10-1 - H10-a-1 (BUS LINE)	Always	Below 1 Ω
H10-2 - H10-a-5 (IG)	Always	Below 1 Ω
H10-3 - H10-a-7 (BUS GND)	Always	Below 1 Ω
H10-4 - H10-a-10 (P GND)	Always	Below 1 Ω

NG

REPAIR OR REPLACE HARNESS OR CONNECTOR

OK

3 CHECK HARNESS AND CONNECTOR (AFS ECU GROUND CIRCUIT)

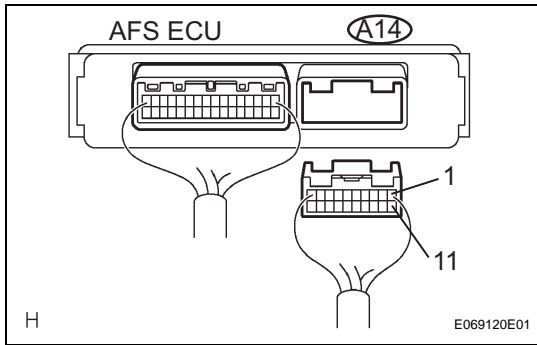

- (a) Disconnect the AFS ECU connector.
- (b) Measure the resistance according to the value(s) in the table below.

Resistance

Tester connection	Condition	Specified condition
A14-1 (E1) - Body ground	Always	Below 1 Ω
A14-11 (E1S) - Body ground	Always	Below 1 Ω

NG → REPAIR OR REPLACE HARNESS OR CONNECTOR

OK

4 INSPECT HEADLIGHT SWIVEL ECU

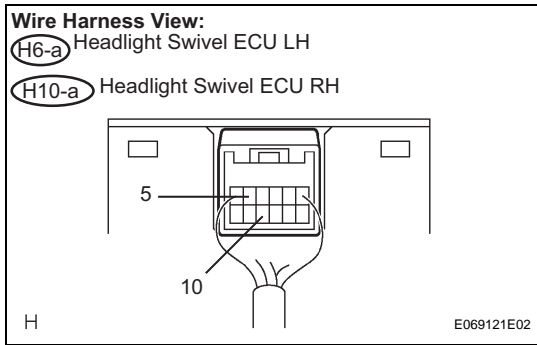

- (a) Disconnect the headlight swivel ECU connector.
- (b) Measure the voltage according to the value(s) in the table below.

Voltage:
LH Side (B2410)

Tester connection	Condition	Specified condition
IG (H6-a-5) - P GND (H6-a-10)	Ignition switch OFF → ON	Below 1 V → 10 to 14 V

RH Side (B2411)

Tester connection	Condition	Specified condition
IG (H10-a-5) - P GND (H10-a-10)	Ignition switch OFF → ON	Below 1 V → 10 to 14 V

Result

Condition	Proceed to
NG	A
OK (When checking from the DTC)	B
OK (When checking from the PROBLEM SYMPTOMS TABLE)	C

B → Go to step 9

C PROCEED TO NEXT CIRCUIT INSPECTION SHOWN IN PROBLEM SYMPTOMS TABLE

A

REPLACE AFS ECU

5 CHECK DTC OUTPUT (AIR SUSPENSION SYSTEM)

(a) Check the DTC of the air suspension system (See page [SC-8](#)).

OK:

Normal system code is output.

NG GO TO FLOW CHART

OK

6 CHECK HARNESS AND CONNECTOR (AFS ECU - HEADLIGHT SWIVEL ECU)

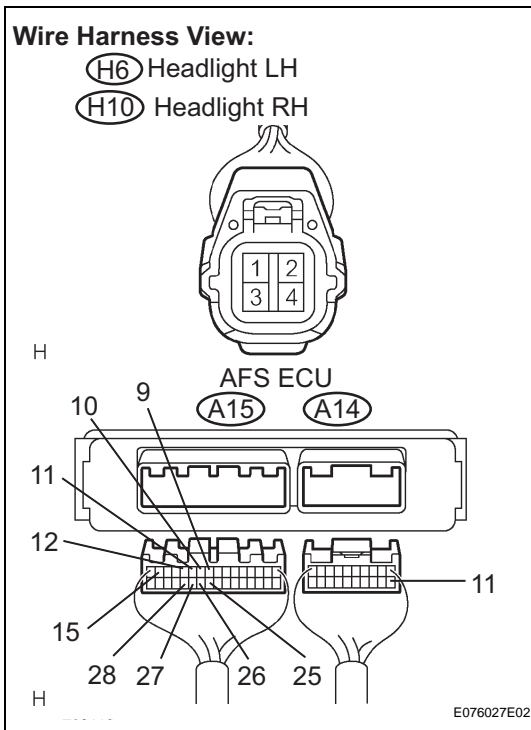

(a) Disconnect the AFS ECU connector and headlight connector on the headlight swivel ECU side.
(b) Measure the resistance according to the value(s) in the table below.

Resistance:

LH Side (B2410)

Tester connection	Condition	Specified condition
A15-25 (SBLL) - H6-1	Always	Below 1 Ω
A15-26 (SBGL) - H6-3	Always	Below 1 Ω
A15-28 (IGSL) - H6-2	Always	Below 1 Ω
A15-25 - Body ground	Always	10 kΩ or higher
A15-26 - Body ground	Always	10 kΩ or higher
A15-28 - Body ground	Always	10 kΩ or higher

RH Side (B2411)

Tester connection	Condition	Specified condition
A15-9 (SBLR) - H10-1	Always	Below 1 Ω
A15-10 (SBGR) - H10-3	Always	Below 1 Ω
A15-12 (IGSR) - H10-2	Always	Below 1 Ω
A15-9 - Body ground	Always	10 kΩ or higher
A15-10 - Body ground	Always	10 kΩ or higher
A15-12 - Body ground	Always	10 kΩ or higher

Connector Front View:

(H6) Headlight LH (H10) Headlight RH

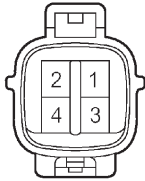

Wire Harness View:

(H6-a) Headlight Swivel ECU LH

(H10-a) Headlight Swivel ECU RH

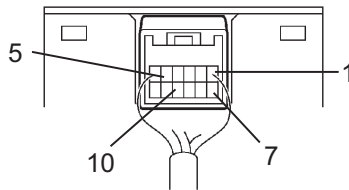

H

E069149E03

- (c) Disconnect the headlight connector on the headlight swivel ECU side and the headlight swivel ECU connector.
- (d) Measure the resistance according to the value(s) in the table below.

**Resistance:
LH Side (B2410)**

Tester connection	Condition	Specified condition
H6-1 - H6-a-1 (BUS LINE)	Always	Below 1 Ω
H6-2 - H6-a-5 (IG)	Always	Below 1 Ω
H6-3 - H6-a-7 (BUS GND)	Always	Below 1 Ω
H6-4 - H6-a-10 (P GND)	Always	Below 1 Ω

RH Side (B2411)

Tester connection	Condition	Specified condition
H10-1 - H10-a-1 (BUS LINE)	Always	Below 1 Ω
H10-2 - H10-a-5 (IG)	Always	Below 1 Ω
H10-3 - H10-a-7 (BUS GND)	Always	Below 1 Ω
H10-4 - H10-a-10 (P GND)	Always	Below 1 Ω

NG

REPAIR OR REPLACE HARNESS OR CONNECTOR

OK

7 CHECK HARNESS AND CONNECTOR (HEADLIGHT SWIVEL ECU GROUND CIRCUIT)

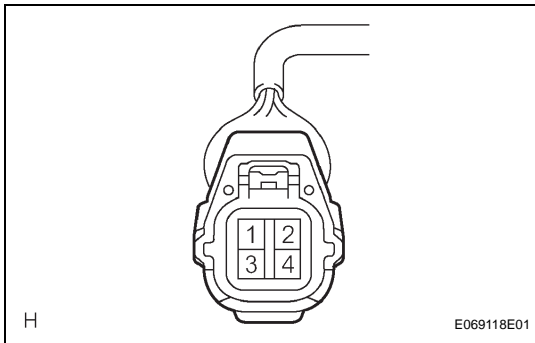

- (a) Disconnect the headlight connector on the headlight swivel ECU side.
- (b) Measure the resistance according to the value(s) in the table below.

Resistance:
LH Side (B2410)

Tester connection	Condition	Specified condition
H6-4 - Body ground	Always	Below 1 Ω

RH Side (B2411)

Tester connection	Condition	Specified condition
H10-4 - Body ground	Always	Below 1 Ω

NG → **REPAIR OR REPLACE HARNESS OR CONNECTOR**

OK

8 INSPECT HEADLIGHT SWIVEL ECU

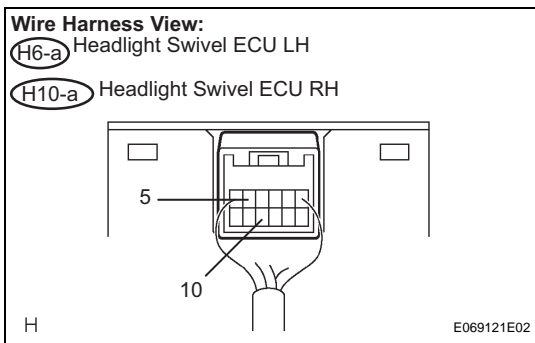

- (a) Disconnect the headlight swivel ECU connector.
- (b) Measure the voltage according to the value(s) in the table below.

Voltage:
LH Side (B2410)

Tester connection	Condition	Specified condition
H6-a-5(IG) - H6-a-10 (P GND)	Ignition switch OFF → ON	Below 1 V → 10 to 14 V

RH Side (B2411)

Tester connection	Condition	Specified condition
H10-a-5 (IG) - H10-a-10 (P GND)	Ignition switch OFF → ON	Below 1 V → 10 to 14 V

Result

Condition	Proceed to
OK (When checking from the DTC)	A
OK (When checking from the PROBLEM SYMPTOMS TABLE)	B
NG	C

B → PROCEED TO NEXT CIRCUIT INSPECTION SHOWN IN PROBLEM SYMPTOMS TABLE

C → REPLACE AFS ECU

A

9 REPLACE HEADLIGHT SWIVEL ECU

OK:
Returns to normal operation.

NG → REPLACE AFS ECU

OK

END

