

<b>DTC</b>	<b>B2603</b>	<b>Tilt and Telescopic Manual Switch Circuit Malfunction</b>
------------	--------------	--

**DESCRIPTION**

Different voltage values are input to the multiplex tilt and telescopic ECU by operating the manual switch. The multiplex tilt and telescopic ECU then judges which motor and in which direction that motor should be moved based on the voltage value.

DTC No.	Detection Item	Trouble Area
B2603	Abnormal voltage value, which is not within the specification, is input to the multiplex tilt and telescopic ECU when being operated by the manual switch.	<ul style="list-style-type: none"> <li>• Tilt and telescopic manual switch</li> <li>• Tilt and telescopic manual switch circuit</li> <li>• Multiplex tilt and telescopic ECU</li> </ul>

SR

**WIRING DIAGRAM**

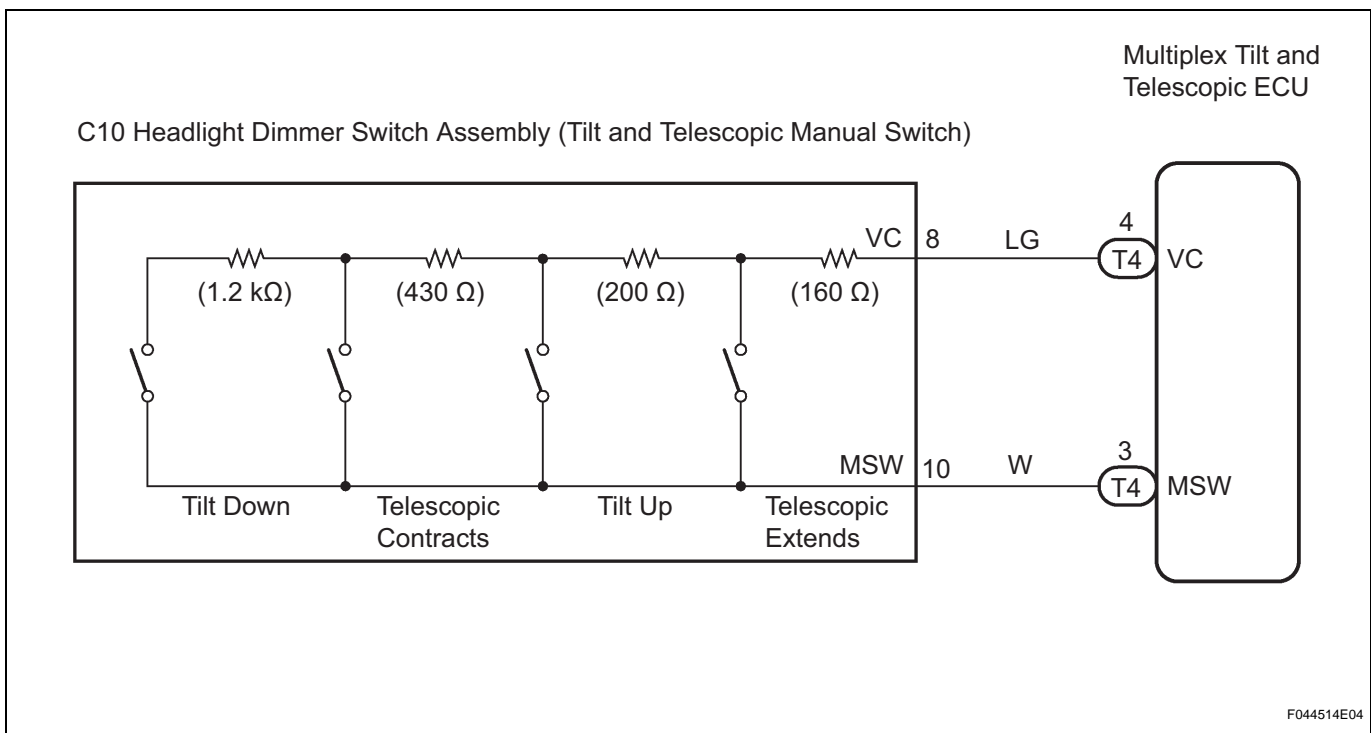

**1 READ VALUE OF INTELLIGENT TESTER**

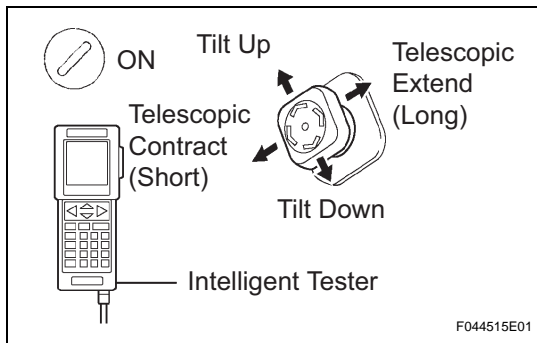

- (a) Connect the intelligent tester to the DLC3.
- (b) Turn the ignition switch to the ON position and turn on the intelligent tester.
- (c) Select "T & T MANUAL SW" from the DATA LIST.
- (d) Read voltages on the tester screen when operating the manual switch.

**Voltage**

Manual switch position	Specified value
<b>Neutral</b>	<b>Below 0.2 V</b>
<b>Tilt up</b>	<b>1.67 to 2.13 V</b>
<b>Tilt down</b>	<b>0.54 to 0.74 V</b>

SR

Manual switch position	Specified value
Telescopic contract	1.08 to 1.40 V
Telescopic extend	2.22 to 2.77 V

**Result**

Proceed to	Result
A	Switch voltages in all directions are within the standard.
B	Switch voltages in certain directions are outside the standard.
C	Switch voltages in all directions are outside the standard.

**A** → REPLACE MULTIPLEX TILT AND TELESCOPIC ECU

**B** → REPLACE HEADLIGHT DIMMER SWITCH ASSEMBLY

**C**

**2 CHECK HARNESS AND CONNECTOR (TILT AND TELESCOPIC ECU - TILT AND TELESCOPIC SWITCH)**

**Multiplex Tilt and Telescopic ECU:**

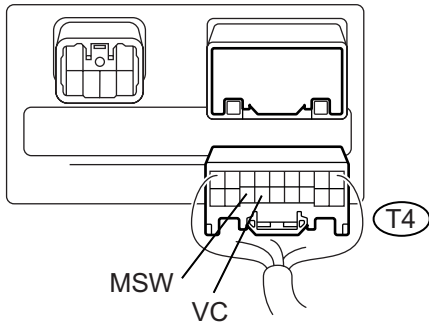

**Headlight Dimmer Switch Assembly:**

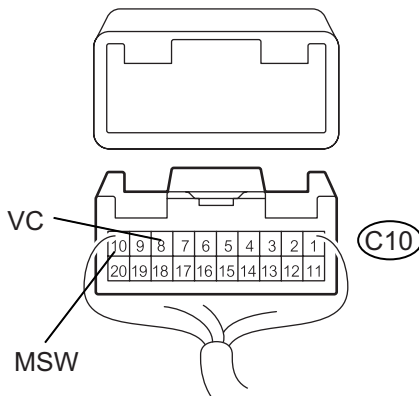

H

C104131E03

- (a) Disconnect the T4 connector from the multiplex tilt and telescopic ECU.
- (b) Disconnect the C10 connector from the headlight dimmer switch assembly.
- (c) Measure the resistance according to the value(s) in the table below.

**Resistance**

Tester connection (Terminal No.)	Condition	Specified value
VC (T4-4) - VC (C10-8)	Always	Below 1 Ω
MSW (T4-3) - MSW (C10-10)	Always	Below 1 Ω
VC (C10-8) - Body ground	Always	10 kΩ or higher
MSW (C10-10) - Body ground	Always	10 kΩ or higher

**NG** → REPAIR OR REPLACE HARNESS OR CONNECTOR

**OK**

SR

**3 INSPECT MULTIPLEX TILT AND TELESCOPIC ECU (VC TERMINAL VOLTAGE)**

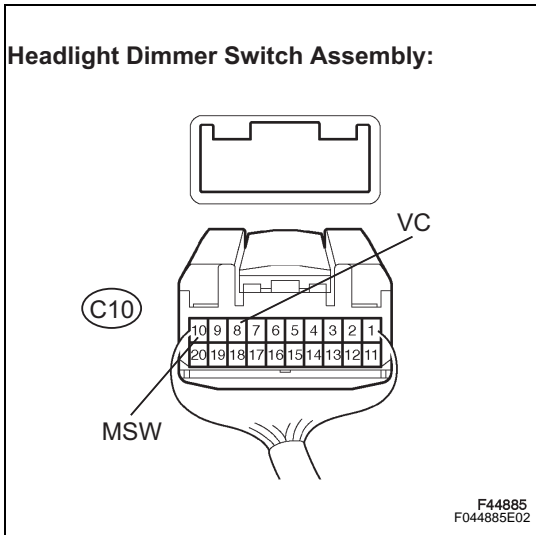

- (a) Reconnect the T4 connector to the multiplex tilt and telescopic ECU.
- (b) Measure the voltage according to the value(s) in the table below.

**Voltage**

Tester connection (Terminal No.)	Condition	Specified value
VC (C10-8) - MSW (C10-10)	IG switch ON	4.9 to 5.1 V

**NG** → REPLACE MULTIPLEX TILT AND TELESCOPIC ECU

OK

**4 INSPECT HEADLIGHT DIMMER SWITCH ASSEMBLY (TILT AND TELESCOPIC MANUAL SWITCH)**

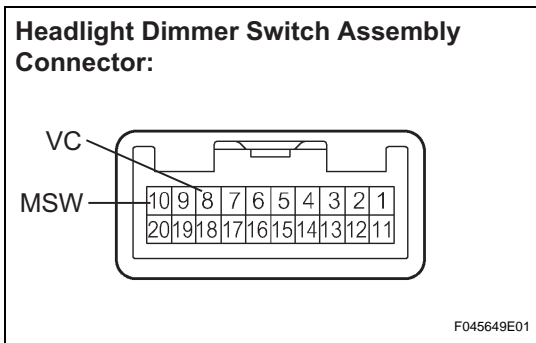

- (a) Measure the resistance according to the value(s) in the table below.

**Resistance**

Tester connection	Condition (Manual switch position)	Specified value
VC - MSW	Tilt up	360 Ω
	Tilt down	1,990 Ω
	Telescopic contract	790 Ω
	Telescopic extend	160 Ω

**NG** → REPLACE HEADLIGHT DIMMER SWITCH ASSEMBLY

OK

REPLACE MULTIPLEX TILT AND TELESCOPIC ECU