

DTC	B1161/84	Open in Curtain Shield Squib RH Circuit
------------	-----------------	--

DESCRIPTION

The curtain shield squib RH circuit consists of the center airbag sensor assembly and the curtain shield airbag assembly RH.

The circuit instructs the SRS to deploy when deployment conditions are met.

DTC B1161/84 is recorded when an open circuit is detected in the curtain shield squib RH circuit.

DTC No.	DTC Detecting Condition	Trouble Area
B1161/84	<ul style="list-style-type: none"> • Open circuit in ICR+ wire harness or ICR- wire harness of curtain shield squib RH • Curtain shield squib RH malfunction • Center airbag sensor assembly malfunction 	<ul style="list-style-type: none"> • Curtain shield airbag assembly RH (Curtain shield squib RH) • Center airbag sensor assembly • Floor wire • Roof wire No.2

RS

WIRING DIAGRAM

See page [RS-199](#).

1	CHECK VEHICLE CONDITION
----------	--------------------------------

- (a) Check whether or not the vehicle is equipped with the rear seat entertainment system.

Result:

A:

w/o Rear seat entertainment system

B:

w/ Rear seat entertainment system

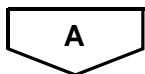

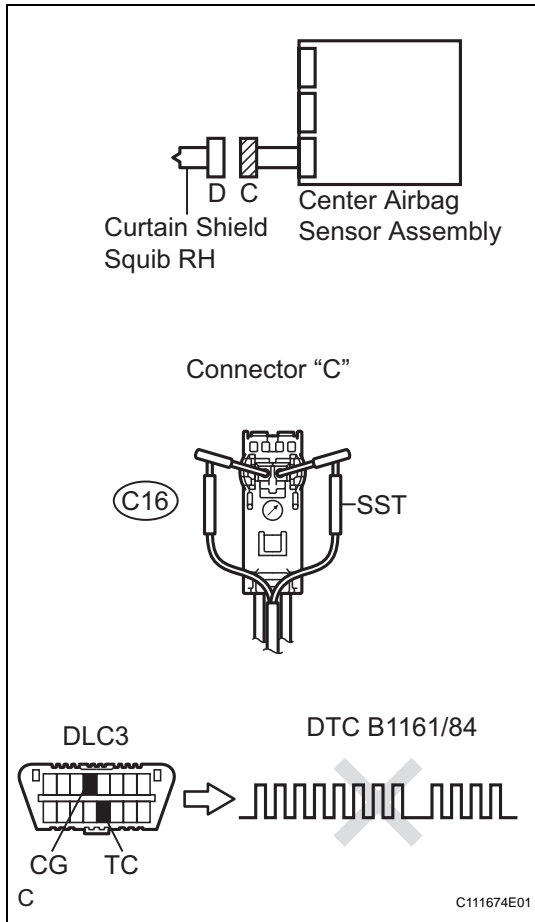
2**CHECK CURTAIN SHIELD AIRBAG ASSEMBLY RH (CURTAIN SHIELD SQUIB RH)**

- (a) Turn the ignition switch to the LOCK position.
- (b) Disconnect the negative (-) terminal cable from the battery, and wait for at least 90 seconds.
- (c) Disconnect the connectors from the curtain shield airbag assembly RH.
- (d) Connect the white wire side of SST (resistance 2.1 Ω) to the floor wire.

CAUTION:

Never connect a tester to the curtain shield airbag assembly RH (Curtain shield squib RH) for measurement, as this may lead to a serious injury due to airbag deployment.

NOTICE:

Do not forcibly insert the SST into the terminals of the connector when connecting.

Insert the SST straight into the terminals of the connector.

SST 09843-18060

- (e) Connect the negative (-) terminal cable to the battery, and wait for at least 2 seconds.
- (f) Turn the ignition switch to the ON position, and wait for at least 60 seconds.
- (g) Clear the DTCs stored in memory (See page [RS-32](#)).
- (h) Turn the ignition switch to the LOCK position.
- (i) Turn the ignition switch to the ON position, and wait for at least 60 seconds.
- (j) Check the DTCs (See page [RS-32](#)).

OK:

DTC B1161/84 is not output.

HINT:

Codes other than DTC B1161/84 may be output at this time, but they are not related to this check.

NG**Go to step 3****OK****REPLACE CURTAIN SHIELD AIRBAG ASSEMBLY RH**

3 CHECK FLOOR WIRE (CURTAIN SHIELD SQUIB RH CIRCUIT)

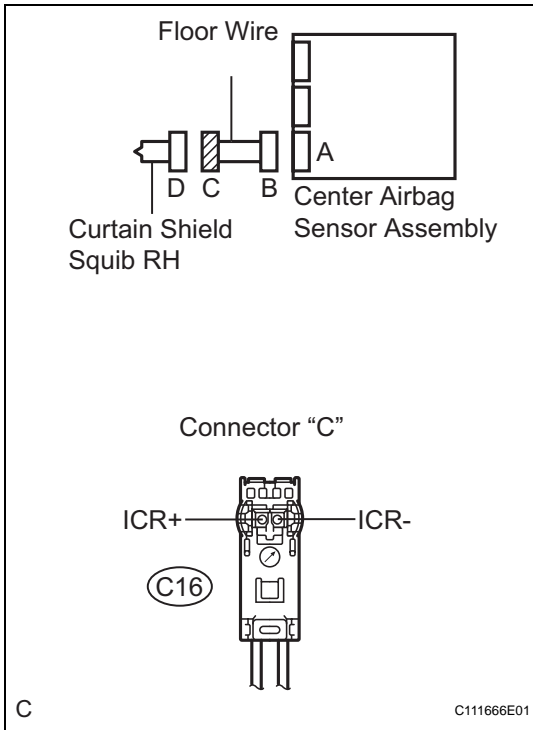

- (a) Disconnect the connector from the center airbag sensor assembly.
- (b) Measure the resistance according to the value(s) in the table below.

Resistance

Tester connection	Condition	Specified condition
C16-1 (ICR+) - C16-2 (ICR-)	Always	Below 1 Ω

NG REPAIR OR REPLACE FLOOR WIRE

OK

4 CHECK CENTER AIRBAG SENSOR ASSEMBLY

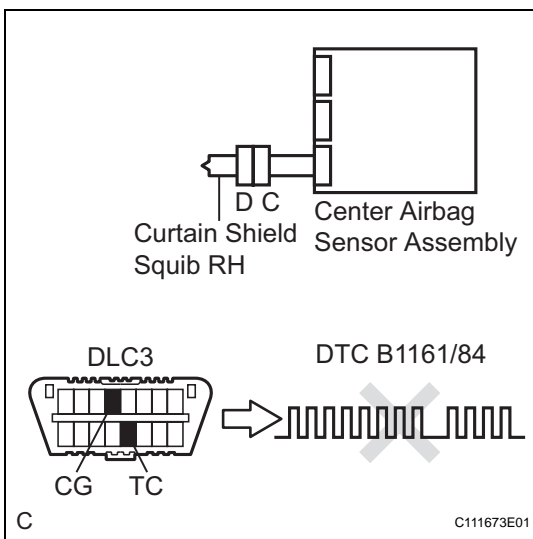

- (a) Connect the connectors to the curtain shield airbag assembly RH and the center airbag sensor assembly.
- (b) Connect the negative (-) terminal cable to the battery, and wait for at least 2 seconds.
- (c) Turn the ignition switch to the ON position, and wait for at least 60 seconds.
- (d) Clear the DTCs stored in memory (See page RS-32).
- (e) Turn the ignition switch to the LOCK position.
- (f) Turn the ignition switch to the ON position, and wait for at least 60 seconds.
- (g) Check the DTCs (See page RS-32).

OK:

DTC B1161/84 is not output.

HINT:

Codes other than DTC B1161/84 may be output at this time, but they are not related to this check.

NG REPLACE CENTER AIRBAG SENSOR ASSEMBLY

OK

USE SIMULATION METHOD TO CHECK

5 CHECK CURTAIN SHIELD AIRBAG ASSEMBLY RH (CURTAIN SHIELD SQUIB RH)

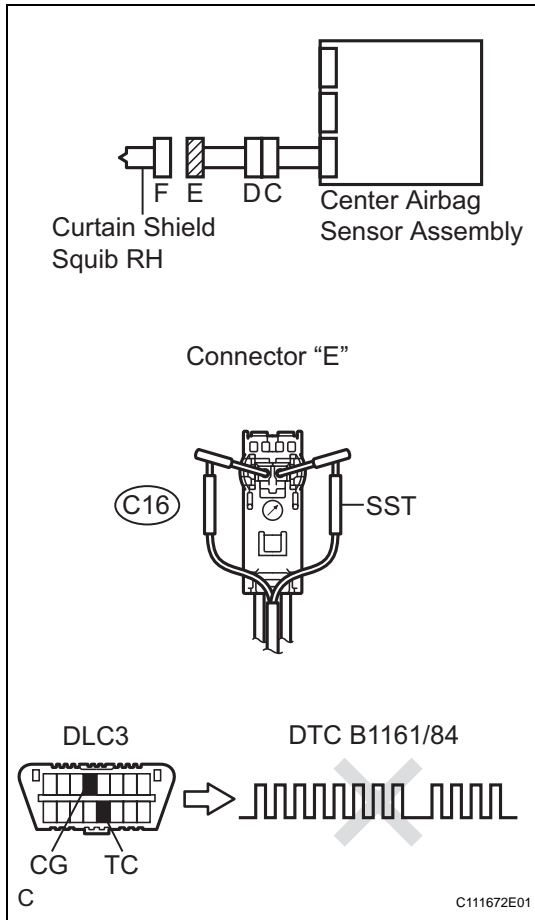

- Turn the ignition switch to the LOCK position.
- Disconnect the negative (-) terminal cable from the battery, and wait for at least 90 seconds.
- Disconnect the connectors from the curtain shield airbag assembly RH.
- Connect the white wire side of SST (resistance 2.1 Ω) to the roof wire No.2.

CAUTION:

Never connect a tester to the curtain shield airbag assembly RH (Curtain shield squib RH) for measurement, as this may lead to a serious injury due to airbag deployment.

NOTICE:

Do not forcibly insert the SST into the terminals of the connector when connecting.

Insert the SST straight into the terminals of the connector.

SST 09843-18060

- Connect the negative (-) terminal cable to the battery, and wait for at least 2 seconds.
- Turn the ignition switch to the ON position, and wait for at least 60 seconds.
- Clear the DTCs stored in memory (See page RS-32).
- Turn the ignition switch to the LOCK position.
- Turn the ignition switch to the ON position, and wait for at least 60 seconds.
- Check the DTCs (See page RS-32).

OK:

DTC B1161/84 is not output.

HINT:

Codes other than DTC B1161/84 may be output at this time, but they are not related to this check.

NG

Go to step 6

OK

REPLACE CURTAIN SHIELD AIRBAG ASSEMBLY RH

6 CHECK CURTAIN SHIELD SQUIB RH CIRCUIT

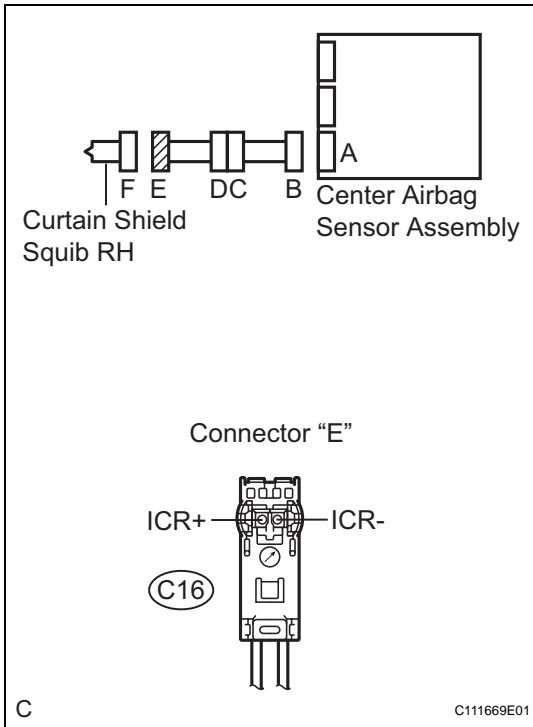

- (a) Disconnect the connector from the center airbag sensor assembly.
- (b) Measure the resistance according to the value(s) in the table below.

Resistance

Tester connection	Condition	Specified condition
C16-1 (ICR+) - C16-2 (ICR-)	Always	Below 1 Ω

NG

Go to step 8

RS

OK

7 CHECK CENTER AIRBAG SENSOR ASSEMBLY

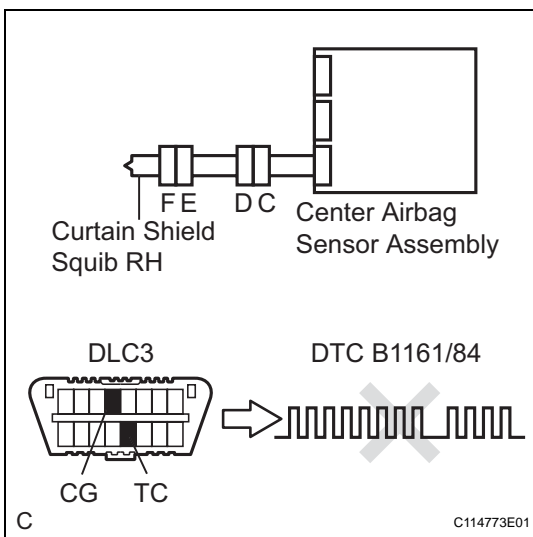

- (a) Connect the connectors to the curtain shield airbag assembly RH and the center airbag sensor assembly.
- (b) Connect the negative (-) terminal cable to the battery, and wait for at least 2 seconds.
- (c) Turn the ignition switch to the ON position, and wait for at least 60 seconds.
- (d) Clear the DTCs stored in memory (See page RS-32).
- (e) Turn the ignition switch to the LOCK position.
- (f) Turn the ignition switch to the ON position, and wait for at least 60 seconds.
- (g) Check the DTCs (See page RS-32).

OK:

DTC B1161/84 is not output.

HINT:

Codes other than DTC B1161/84 may be output at this time, but they are not related to this check.

NG

REPLACE CENTER AIRBAG SENSOR ASSEMBLY

OK

USE SIMULATION METHOD TO CHECK

8 CHECK FLOOR WIRE

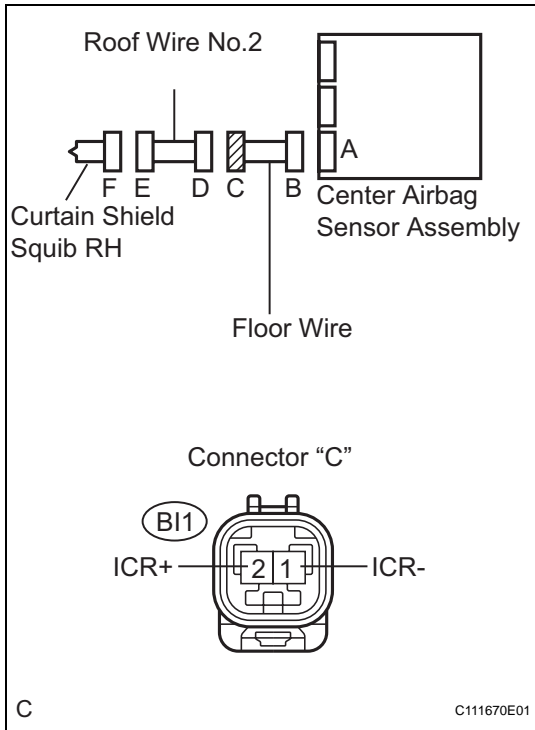

- (a) Disconnect the floor wire connector from the roof wire No.2.
- (b) Measure the resistance according to the value(s) in the table below.

Resistance

Tester connection	Condition	Specified condition
BI1-2 (ICR+) - BI1-1 (ICR-)	Always	Below 1 Ω

NG

REPAIR OR REPLACE FLOOR WIRE

OK

9 CHECK ROOF WIRE NO.2

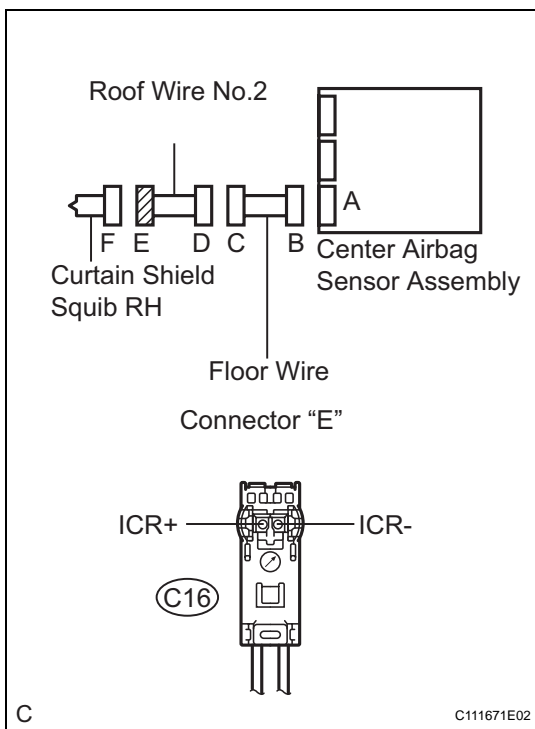

- (a) Measure the resistance according to the value(s) in the table below.

Resistance

Tester connection	Condition	Specified condition
C16-1 (ICR+) - C16-2 (ICR-)	Always	Below 1 Ω

NG

REPAIR OR REPLACE ROOF WIRE NO.2

OK

USE SIMULATION METHOD TO CHECK

RS