

DTC**B0106/54****Open in Front Passenger Side Squib Circuit****DESCRIPTION**

The front passenger side squib circuit consists of the center airbag sensor assembly and the front passenger airbag assembly.

The circuit instructs the SRS to deploy when deployment conditions are met.

DTC B0106/54 is recorded when an open circuit is detected in the front passenger side squib circuit.

DTC No.	DTC Detecting Condition	Trouble Area
B0106/54	<ul style="list-style-type: none"> Open circuit in P+ wire harness or P- wire harness of front passenger side squib Front passenger side squib malfunction Center airbag sensor assembly malfunction 	<ul style="list-style-type: none"> Front passenger airbag assembly (Front passenger side squib) Center airbag sensor assembly Instrument panel wire

RS**WIRING DIAGRAM**

See page [RS-58](#).

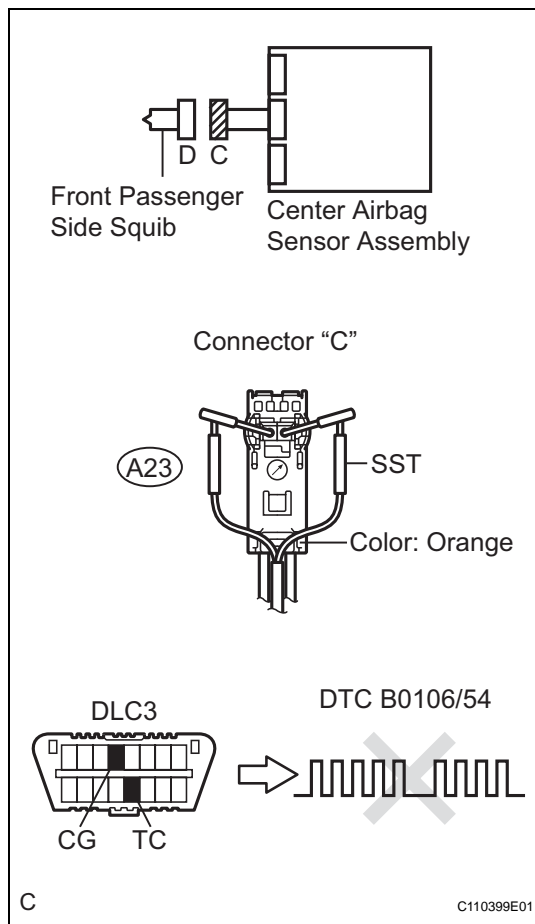
1**CHECK FRONT PASSENGER AIRBAG ASSEMBLY (FRONT PASSENGER SIDE SQUIB)**

- Turn the ignition switch to the LOCK position.
- Disconnect the negative (-) terminal cable from the battery, and wait for at least 90 seconds.
- Disconnect the connectors from the front passenger airbag assembly.
- Connect the white wire side of SST (resistance 2.1 Ω) to the instrument panel wire.

CAUTION:

Never connect a tester to the front passenger airbag assembly (Front passenger side squib) for measurement, as this may lead to a serious injury due to airbag deployment.

NOTICE:

Do not forcibly insert the SST into the terminals of the connector when connecting.

Insert the SST straight into the terminals of the connector.

SST 09843-18060

- Connect the negative (-) terminal cable to the battery, and wait for at least 2 seconds.
- Turn the ignition switch to the ON position, and wait for at least 60 seconds.
- Clear the DTCs stored in memory (See page [RS-32](#)).
- Turn the ignition switch to the LOCK position.
- Turn the ignition switch to the ON position, and wait for at least 60 seconds.
- Check the DTCs (See page [RS-32](#)).

OK:

DTC B0106/54 is not output.

HINT:

Codes other than DTC B0106/54 may be output at this time, but they are not related to this check.

NG

Go to step 2

OK

REPLACE FRONT PASSENGER AIRBAG ASSEMBLY

2 CHECK INSTRUMENT PANEL WIRE (FRONT PASSENGER SIDE SQUIB CIRCUIT)

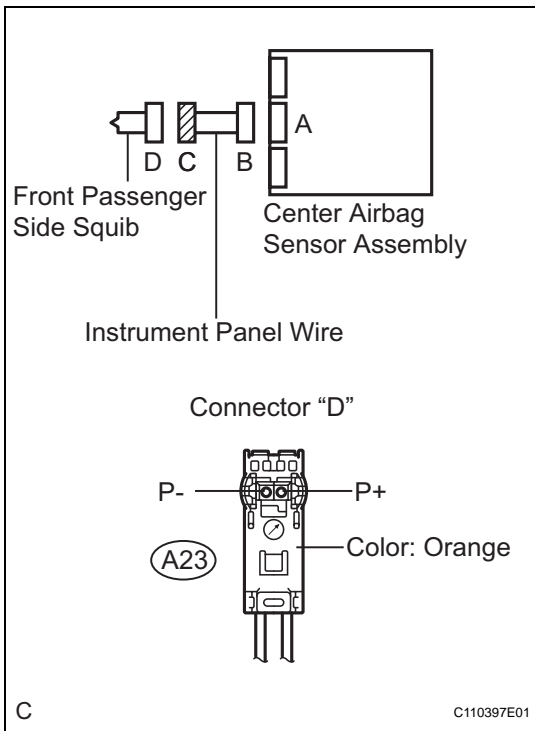

- (a) Disconnect the connector from the center airbag sensor assembly.
- (b) Measure the resistance according to the value(s) in the table below.

Resistance

Tester connection	Condition	Specified condition
A23-2 (P+) - A23-1 (P-)	Always	Below 1 Ω

NG

REPAIR OR REPLACE INSTRUMENT PANEL WIRE

OK

3 CHECK CENTER AIRBAG SENSOR ASSEMBLY

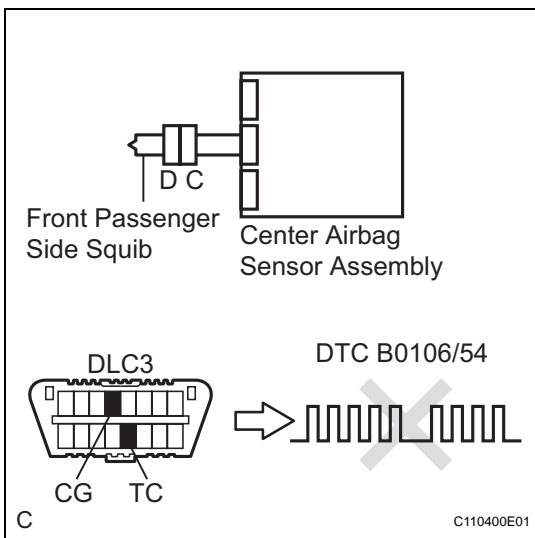

- (a) Connect the connectors to the front passenger airbag assembly and the center airbag sensor assembly.
- (b) Connect the negative (-) terminal cable to the battery, and wait for at least 2 seconds.
- (c) Turn the ignition switch to the ON position, and wait for at least 60 seconds.
- (d) Clear the DTCs stored in memory (See page RS-32).
- (e) Turn the ignition switch to the LOCK position.
- (f) Turn the ignition switch to the ON position, and wait for at least 60 seconds.
- (g) Check the DTCs (See page RS-32).

OK:

DTC B0106/54 is not output.

HINT:

Codes other than code B0106/54 may be output at this time, but they are not related to this check.

NG

REPLACE CENTER AIRBAG SENSOR ASSEMBLY

OK

USE SIMULATION METHOD TO CHECK