

DTC	B0115/47	Short in Side Squib LH Circuit
------------	-----------------	---------------------------------------

DESCRIPTION

The side squib LH circuit consists of the center airbag sensor assembly and the front seat side airbag assembly LH (side squib LH).

This circuit instructs the SRS to deploy when deployment conditions are met.

DTC B0115/47 is recorded when a short circuit is detected in the side squib LH circuit.

DTC No.	DTC Detecting Condition	Trouble Area
B0115/47	<ul style="list-style-type: none"> Short circuit between SFL+ wire harness and SFL- wire harness of side squib LH Side squib LH malfunction Center airbag sensor assembly malfunction 	<ul style="list-style-type: none"> Front seat side airbag assembly LH (Side squib LH) Center airbag sensor assembly Floor wire No.2

RS

WIRING DIAGRAM

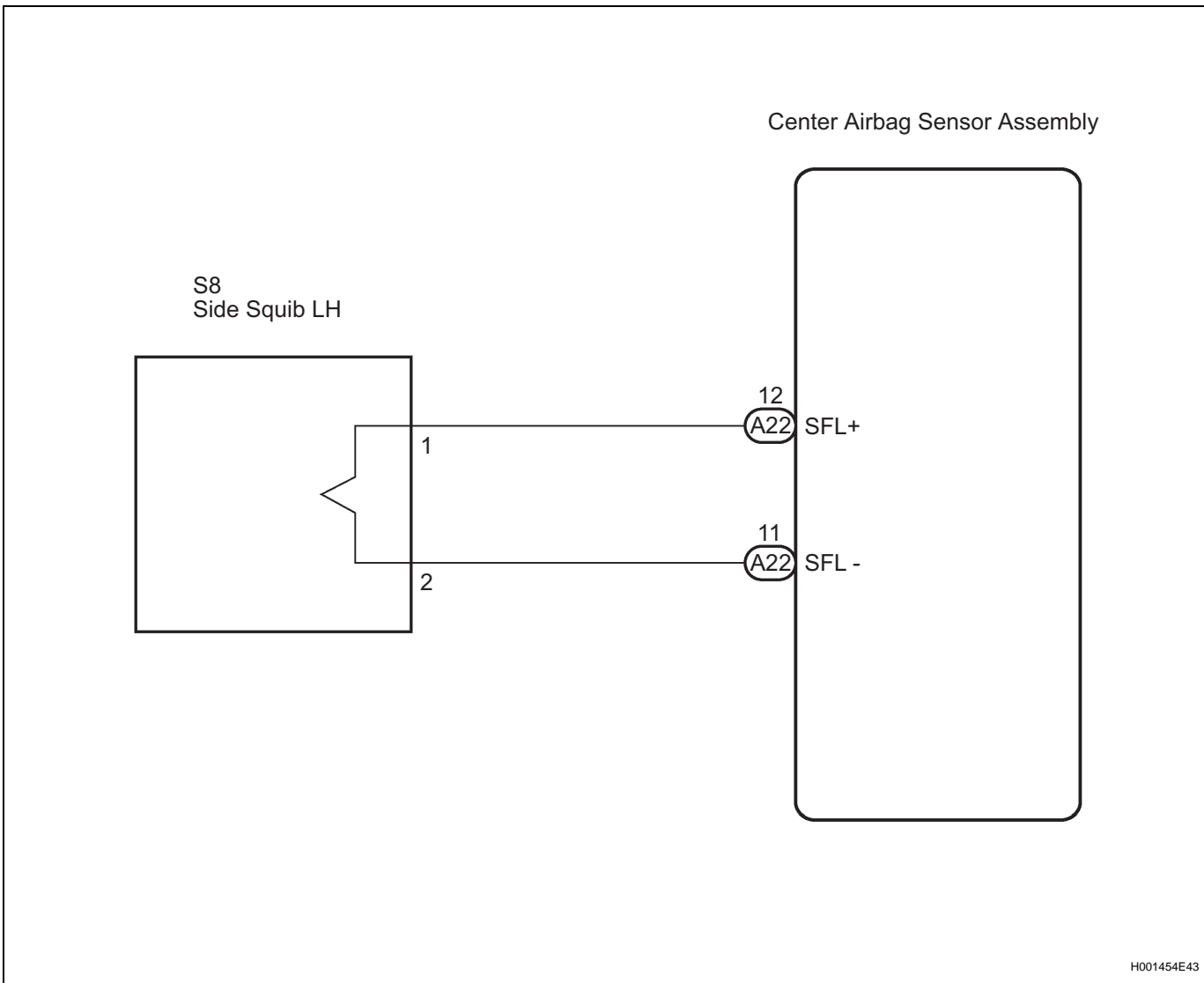

1 CHECK FRONT SEAT AIRBAG ASSEMBLY LH (SIDE SQUIB LH)

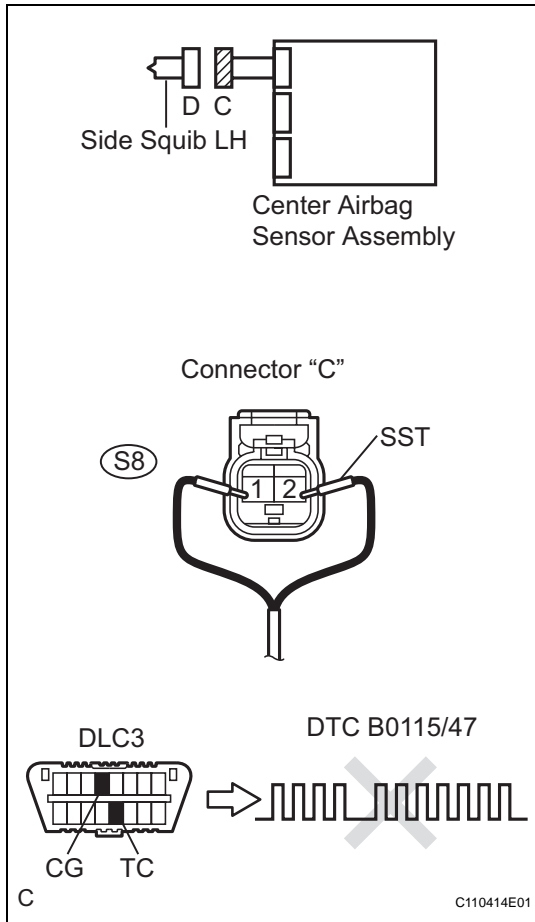

- Turn the ignition switch to the LOCK position.
- Disconnect the negative (-) terminal cable from the battery, and wait for at least 90 seconds.
- Disconnect the connectors from the front seat side airbag assembly LH.
- Connect the black wire side of SST (resistance 2.1 Ω) to the floor wire No.2.

CAUTION:

Never connect a tester to the front seat side airbag assembly LH (Side squib LH) for measurement, as this may lead to a serious injury due to airbag deployment.

NOTICE:

Do not forcibly insert the SST into the terminals of the connector when connecting.

Insert the SST straight into the terminals of the connector.

SST 09843-18060

- Connect the negative (-) terminal cable to the battery, and wait for at least 2 seconds.
- Turn the ignition switch to the ON position, and wait for at least 60 seconds.
- Clear the DTCs stored in memory (See page [RS-32](#)).
- Turn the ignition switch to the LOCK position.
- Turn the ignition switch to the ON position, and wait for at least 60 seconds.
- Check the DTCs (See page [RS-32](#)).

OK:

DTC B0115/47 is not output.

HINT:

Codes other than DTC B0115/47 may be output at this time, but they are not related to this check.

NG

Go to step 2

OK

REPLACE FRONT SEAT AIRBAG ASSEMBLY LH

2 CHECK FLOOR WIRE NO.2 (SIDE SQUIB LH CIRCUIT)

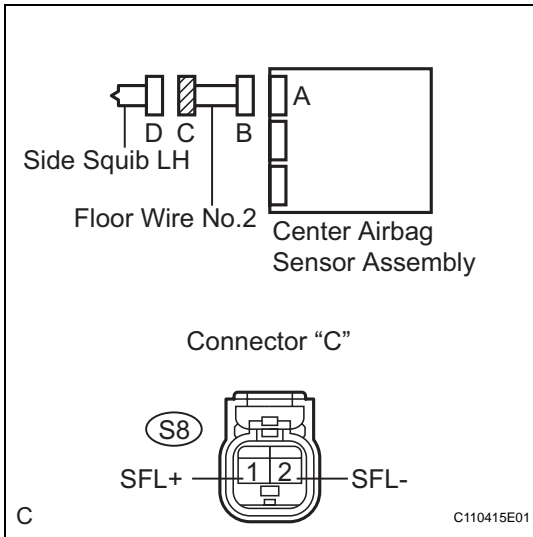

- (a) Disconnect the connector from the center airbag sensor assembly.
- (b) Release the activation prevention mechanism built into connector "B" (See page RS-25).
- (c) Measure the resistance according to the value(s) in the table below.

Resistance

Tester connection	Condition	Specified condition
S8-1 (SFL+) - S8-2 (SFL-)	Always	1 MΩ or higher

NG REPAIR OR REPLACE FLOOR WIRE NO.2

OK

3 CHECK CENTER AIRBAG SENSOR ASSEMBLY

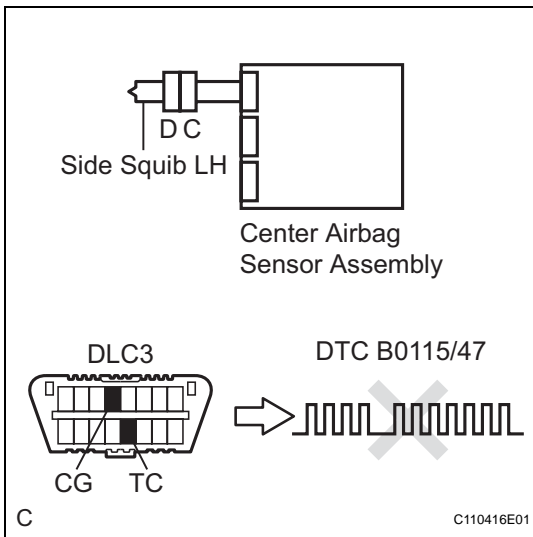

- (a) Connect the connectors to the front seat side airbag assembly LH and the center airbag sensor assembly.
- (b) Connect the negative (-) terminal cable to the battery, and wait for at least 2 seconds.
- (c) Turn the ignition switch to the ON position, and wait for at least 60 seconds.
- (d) Clear the DTCs stored in memory (See page RS-32).
- (e) Turn the ignition switch to the LOCK position.
- (f) Turn the ignition switch to the ON position, and wait for at least 60 seconds.
- (g) Check the DTCs (See page RS-32).

OK:

DTC B0115/47 is not output.

HINT:

Codes other than code B0115/47 may be output at this time, but they are not related to this check.

NG REPLACE CENTER AIRBAG SENSOR ASSEMBLY

OK

USE SIMULATION METHOD TO CHECK