

DTC CHECK / CLEAR

1. DIAGNOSTIC SYSTEM

- (a) Inspect the battery voltage.

Battery voltage:

11 to 14 V

If voltage is below 11 V, recharge the battery before proceeding.

- (b) Check the DLC3.

The vehicle's skid control ECU uses ISO 9141-2 for communication. The terminal arrangement of the DLC3 complies with SAE J1962 and matches with the ISO 9141-2 format.

Verify conditions listed in the table below:

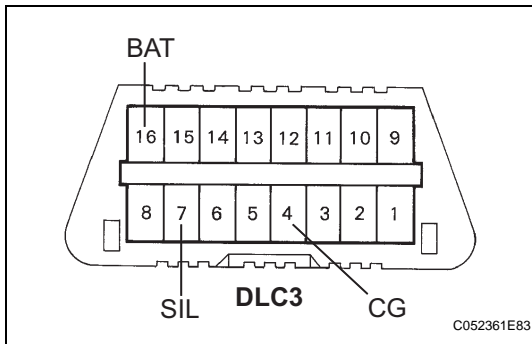

Terminal No.	Terminal name	Connection / Voltage or Resistance	Condition
7	SIL	Bus + Line / Pulse generation	During transmission
4	CG	Chassis Ground to Body Ground / 1 Ω or less	Always
16	BAT	Battery Positive to Body Ground / 10 to 14 V	Always

HINT:

If the intelligent tester displays "UNABLE TO CONNECT TO VEHICLE" when the cable of the intelligent tester is properly connected to the DLC3, the ignition switch is turned to the ON position and the tester is operated, there is either a problem on the vehicle side or tester side.

- If communication is normal when the tester is connected to another vehicle, inspect the DLC3 on the original vehicle.
- If communication is still not possible when the tool is connected to another vehicle, the problem is probably in the tester itself. In this case, consult the Service Department listed in the tester's instruction manual.

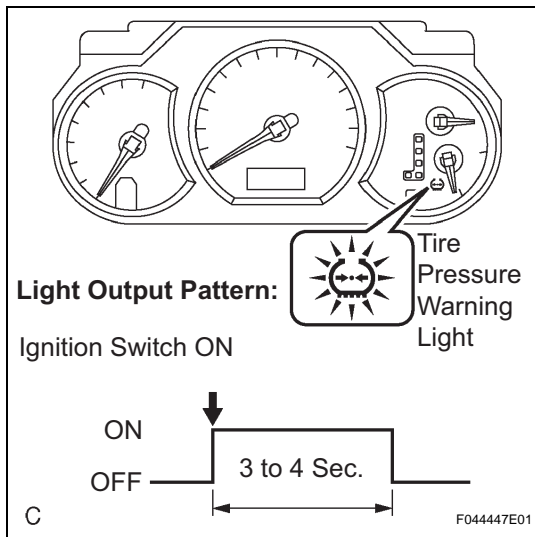

2. CHECK WARNING LIGHT

- (a) Turn the ignition switch to the OFF position.
- (b) When the ignition switch is turned to the ON position, the light should come on for 3 to 4 seconds and then go off.

HINT:

If the tire pressure warning light has a defect, check the tire pressure warning light output patterns and the problem symptoms table.

3. TIRE PRESSURE WARNING LIGHT CHART:

Priority	Condition	Tire Pressure Warning Light Output Pattern
1	Ignition switch is in the ON position	<p>Tire pressure warning light comes on for 3 seconds when the ignition switch is turned to the ON position. (However, during initialization, the light comes on for 4 seconds.)</p> <ul style="list-style-type: none"> • T1: 3 or 4 sec. • A: Ignition switch ON
2	<p>System abnormal 1 Tire pressure warning light signal is open. HINT: When the tire pressure warning light drive signal circuit opens due to a skid control ECU malfunction, communication error, open circuit in the wire harness, etc., the tire pressure warning light comes on. (Active Light Circuit)</p>	<p>Tire pressure warning light comes on</p> <ul style="list-style-type: none"> • B: Signal circuit open
3	<p>System abnormal 2 ABS system malfunction Speed sensor malfunction Stop light switch assembly malfunction HINT: The skid control ECU monitors the speed sensor signal and the stop light switch signal, and the tire pressure warning light blinks.</p>	<p>The pressure warning light blinks (Goes on and off repeatedly at 0.5 second intervals.)</p> <ul style="list-style-type: none"> • T2: 0.5 sec. • C: Malfunction Occurs <p>HINT: When the skid control ECU detects a system abnormal 2 malfunction, check the ABS DTCs and proceed to the pages on which the ABS DTCs are described.</p>

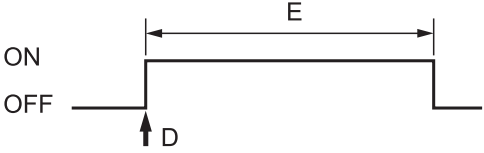
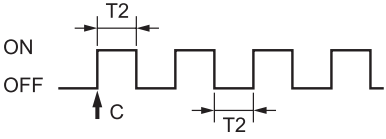
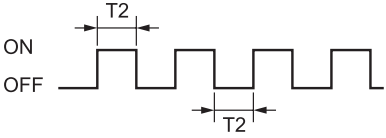
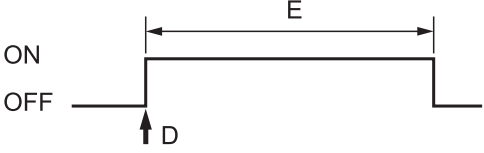
Priority	Condition	Tire Pressure Warning Light Output Pattern
4	Tire pressure warning reset switch is turned on during TEST mode. (Press and hold the tire pressure warning reset switch.)	<p>Tire pressure warning light comes on when the tire pressure warning reset switch is turned on.</p>  <ul style="list-style-type: none"> E: Switch operating D: Switch ON
5	Initialization mode is received. HINT: See step 3 for initialization procedure.	<p>Tire pressure warning light blinks 3 times (Turning on and off repeatedly at 1 second intervals.)</p>  <ul style="list-style-type: none"> T2: 1 sec. C: Switch ON
6	Failure to initialize when driving the vehicle. HINT: 3 conditions will indicate this pattern: 1. New vehicle from factory 2. ECM replacement 3. Failure to initialize	<p>Tire pressure warning light blinks (Turning on and off repeatedly at 0.25 second intervals.)</p>  <ul style="list-style-type: none"> T2: 0.25 sec.
7	Outputs tire air pressure check result. HINT: The result is output only when driving at 19 mph (35 km/h) or more.	<p>Tire pressure is judged to be normal: Warning switch is OFF</p> <p>Tire pressure is judged to be low:</p>  <ul style="list-style-type: none"> B: Judging low tire pressure

HINT:

When the skid control ECU does not operate properly, the ABS warning light comes on as an ABS system malfunction.

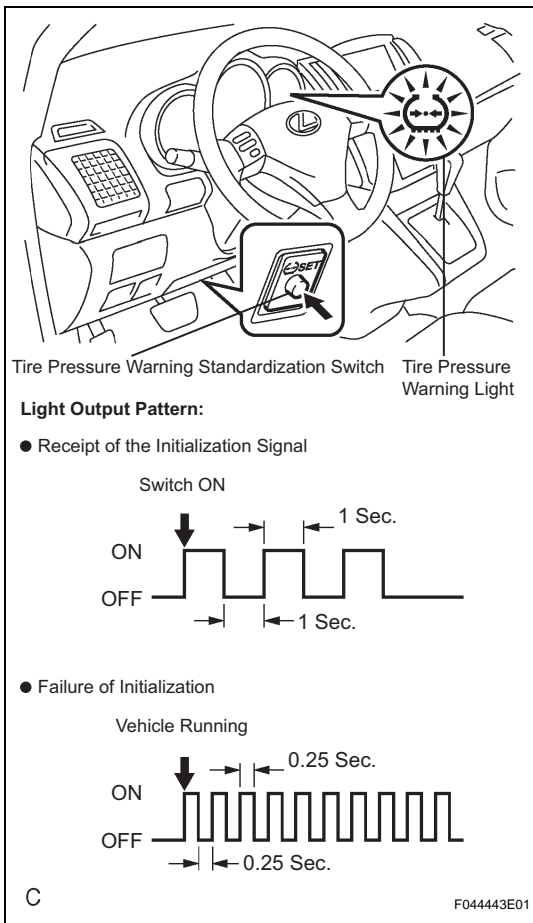

4. INITIALIZING THE TIRE PRESSURE WARNING SYSTEM

- Check and adjust the tire pressure to the specified value (See page TW-1). (Procedure "A")
- With the vehicle stopped, turn the ignition switch to the ON position. (Procedure "B")
- Press and hold the tire pressure warning standardization switch until the tire pressure warning light blinks 3 times at a 1 second interval. (Procedure "C")

HINT:

If the tire pressure warning light does not blink, perform the initialization again. (with the ignition switch off, perform the procedure above starting at procedure "B".)

- Drive the vehicle at 30 km/h (19 mph) or more, to complete the initialization of the skid control ECU. (It takes about 0.5 to 1.0 hour.) (Procedure "D")

HINT:

If the tire pressure warning light blinks at 0.25 second intervals while the vehicle is being driven, the initialization may have failed. If so, perform the initialization again. (Turn the ignition switch OFF and retry from procedure "A".)

- After initialization, is completed the skid control ECU monitors the tire pressure. Using the wheel speed sensors. (Procedure "E")
- To verify the system has been initialized check the length of time the tire pressure warning light is on after turning the ignition switch to the ON position. (Procedure "F")
 - Not initialized: 4 sec.
 - Initialized: 3 sec.

5. DIAGNOSTIC SYSTEM

- Inspect the battery voltage.

Battery voltage:

11 to 14 V

If voltage is below 11 V, recharge the battery before proceeding.

- Check DLC3.

The vehicle's skid control ECU uses ISO 9141-2 for communication. The terminal arrangement of DLC3 complies with SAE J1962 and matches with the ISO 9141-2 format.

Verify conditions listed in the table below:

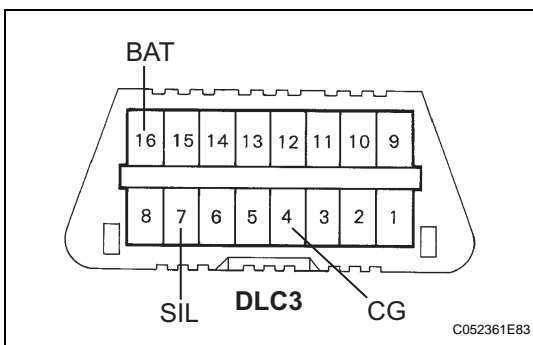

Terminal No.	Terminal name	Connection / Voltage or Resistance	Condition
7	SIL	Bus + Line / Pulse generation	During transmission
4	CG	Chassis Ground to Body Ground / 1 Ω or less	Always
16	BAT	Battery Positive to Body Ground / 10 to 14 V	Always

HINT:

If the intelligent tester displays "UNABLE TO CONNECT TO VEHICLE" when the cable of the intelligent tester is properly connected to DLC3, the ignition switch is turned to the ON position and the tester is operated, there is a problem on the vehicle side or tester side.

- If communication is normal when the tester is connected to another vehicle, inspect DLC3 on the original vehicle.
- If communication is still not possible when the tool is connected to another vehicle, the problem is probably in the tester itself. In this case, consult the Service Department listed in the tester's instruction manual.

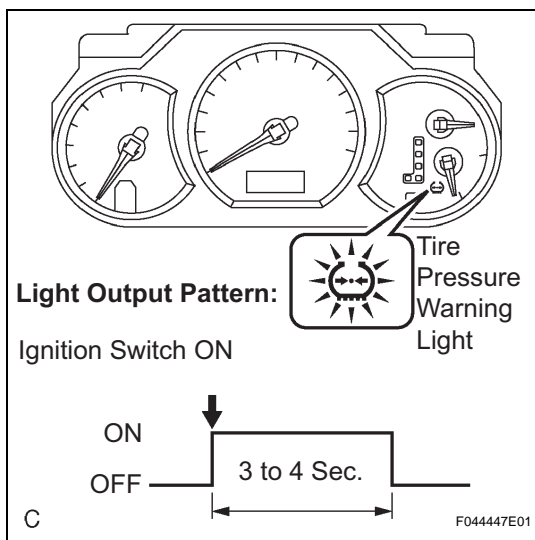
**6. CHECK WARNING LIGHT**

- Turn the ignition switch to the OFF position.
- When the ignition switch is turned to the ON position, the light should come on for 3 to 4 seconds and then go off.

HINT:

If the tire pressure warning light has a defect, check the tire pressure warning light output patterns and the problem symptoms table .

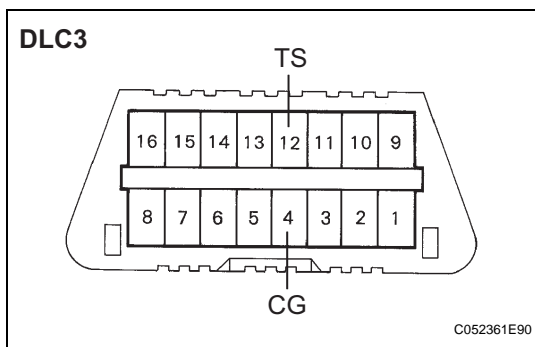
**7. TEST MODE (USING SST CHECK WIRE)**

- Make sure the ignition switch is OFF.
- Using the SST(s), connect the terminals TS and CG of DLC3.

SST 09843-18040

- Turn the ignition switch to the ON position (The tire pressure warning standardization switches to TEST mode).

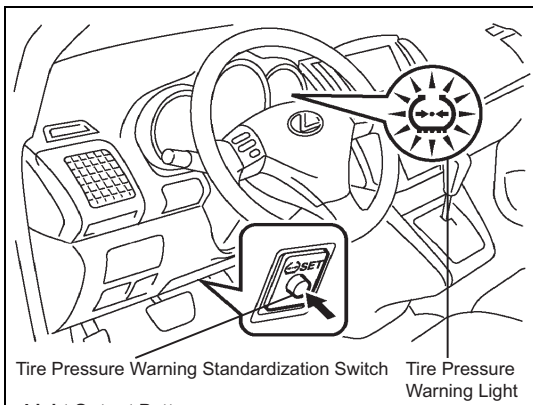

Tire Pressure Warning Standardization Switch Tire Pressure Warning Light

Light Output Pattern:

● Normal Condition

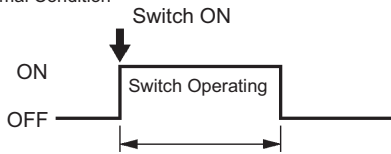

● System Malfunction

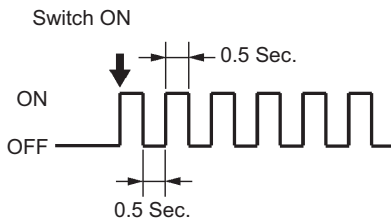

C

F044445E01

- (d) Press the tire pressure warning standardization switch. (Procedure "D")
- (e) Check that the tire pressure warning light comes on.
HINT:
 - Unless the above Procedure "D" is performed, the tire pressure warning light remains off while in TEST mode.
 - When the tire pressure warning system has any problem, the tire pressure warning light blinks at 0.5 seconds interval.

If the light output result is not normal, proceed to the problem symptoms table or TS terminal circuit.

Item	See procedure
Problem symptoms table	TW-6
TS terminal circuit	-

- (f) Turn the ignition switch off.
- (g) Remove the SST(s) from the DLC3.
SST 09843-18040

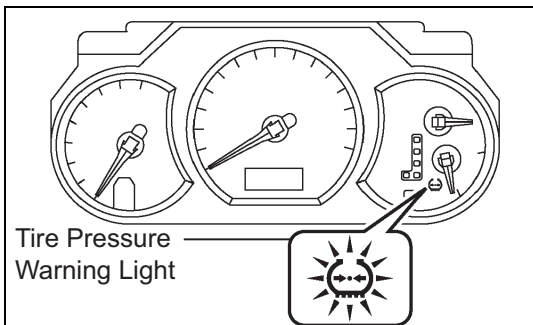

Tire Pressure Warning Light

Light Output Pattern:



C

F044446E01

- (h) Turn the ignition switch to the ON position.
- (i) Check that the tire pressure warning light goes off.
- (j) Initialize the tire pressure warning system (See step 1.).

8. TEST MODE (USING INTELLIGENT TESTER)

- (a) Connect the intelligent tester to DLC3.
- (b) Turn the ignition switch to the ON position.
- (c) Select the "TEST MODE", and proceed checking with the intelligent tester.

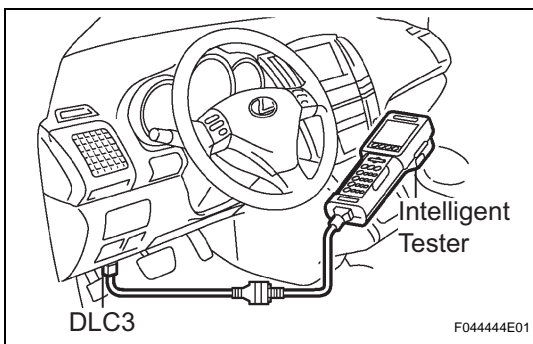

DLC3

F044444E01

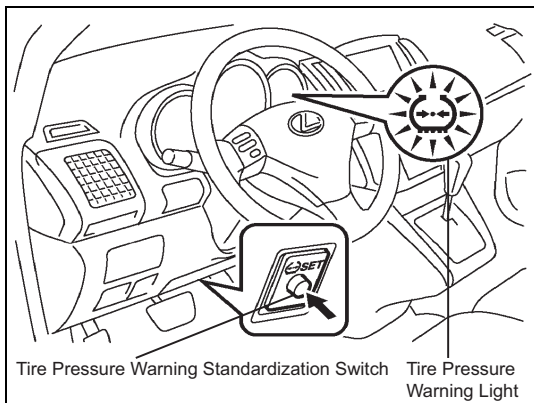

Tire Pressure Warning Standardization Switch Tire Pressure Warning Light

Light Output Pattern:

● Normal Condition

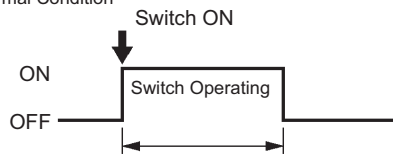

● System Malfunction

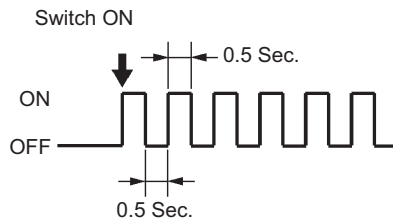

C F044445E01

- (d) Press the tire pressure warning standardization switch. (Procedure "D")
- (e) Check that the tire pressure warning light comes on.
HINT:
 - Unless the above Procedure "D" is performed, the tire pressure warning light remains off while in TEST mode.
 - When the tire pressure warning system has any problem, the tire pressure warning light blinks at 0.5 seconds interval.

If the light output result is not normal, proceed to the problem symptoms table or TS terminal circuit.

Item	See procedure
Problem symptoms table	TW-6
TS terminal circuit	-

- (f) Turn the ignition switch off.

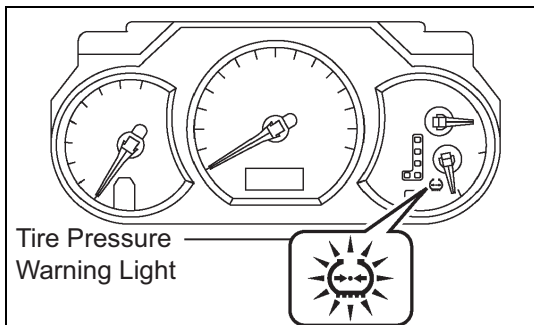

Tire Pressure Warning Light

Light Output Pattern:



C F044446E01

- (g) Turn the ignition switch to the ON position.
- (h) Check that the tire pressure warning light goes off.
- (i) Initialize the tire pressure warning system (See step 1.).

9. DTC CHECK (USING SST CHECK WIRE)

HINT:
Check for DTCs in the ABS system first.

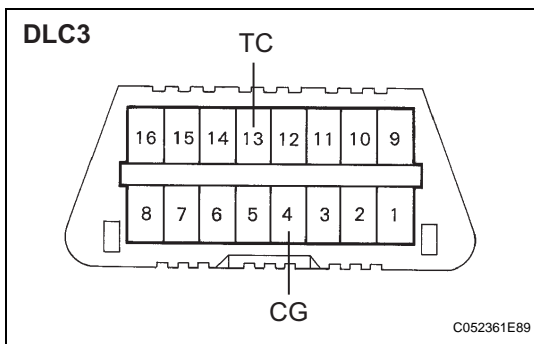

DLC3

TC

CG

C052361E89

- (a) Checking DTCs.
 - (1) Using SST(s), connect terminals TC and CG of DLC3.
SST 09843-18040
 - (2) Turn the ignition switch to the ON position.

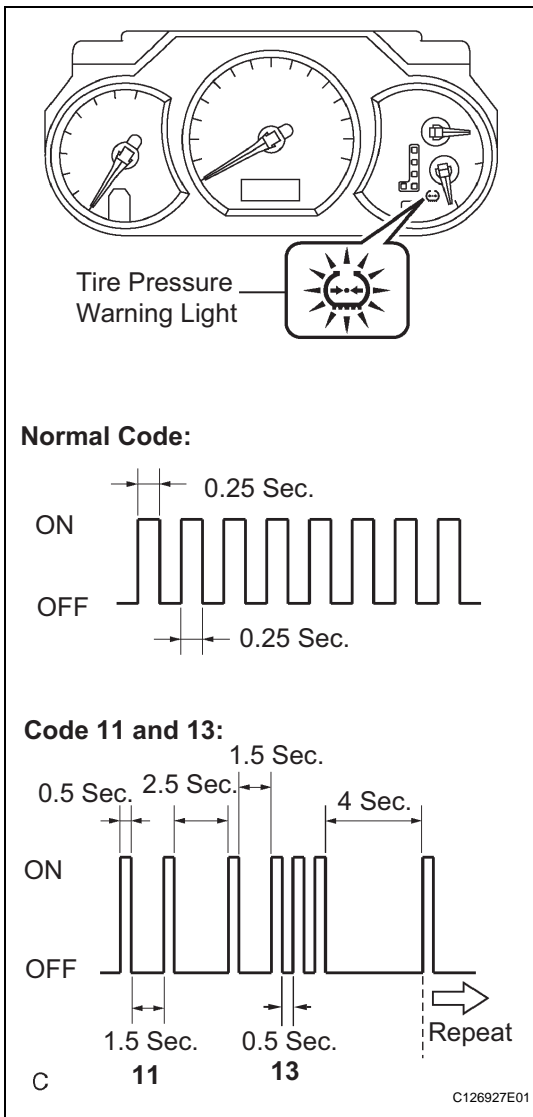

(3) Read and record any DTCs from the tire pressure warning light on the combination meter. Refer to the illustration to the left as examples for a normal system code and codes 11 and 13. HINT:

- If the tire pressure warning light does not blink, inspect the tire pressure warning light circuit or TC terminal circuit.

Trouble Area	See procedure
Tire pressure warning light circuit	TW-24
TC terminal circuit	-

- If 2 or more malfunctions occur at the same time, the lowest numbered DTC is displayed first.
- (4) Refer to the Diagnostic Trouble Code Chart (See page TW-17) for DTCs information.
- (5) After completing the check, turn the ignition switch off then remove SST(s) from DLC3.

SST 09843-18040

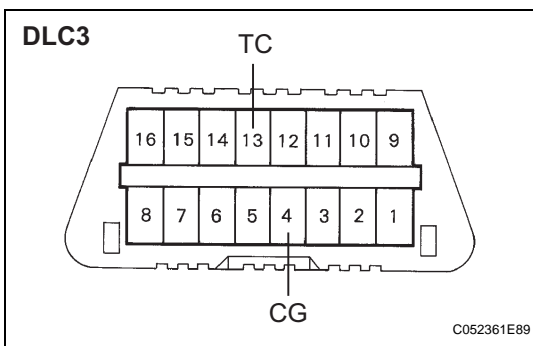

(b) Clearing the DTCs.

- (1) Turn the ignition switch off.
- (2) Using SST(s), connect terminals TC and CG of DLC3.

SST 09843-18040

- (3) Turn the ignition switch to the ON position.

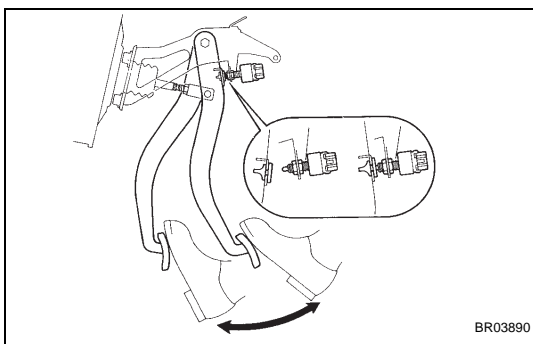

- (4) Clear the DTCs stored in the ECU by depressing the brake pedal 8 times or more within 5 seconds.

- (5) Check that the tire pressure warning light indicates the normal code.

- (6) Turn the ignition switch off, remove SST(s) from DLC3.

SST 09843-18040

HINT:

Disconnecting the battery cable will not erase the DTCs in the ECU.

10. DTC CHECK (USING INTELLIGENT TESTER)

HINT:

Check for DTCs in the ABS system first.

- (a) Checking the DTCs using the intelligent tester.
 - (1) Connect the intelligent tester to DLC3.
 - (2) Turn the ignition switch to the ON position.
 - (3) Read and record the DTCs by following the prompts on the tester screen.

HINT:

Refer to the intelligent tester operator's manual for further details.

- (b) Clearing the DTCs using the intelligent tester.
 - (1) Connect the intelligent tester to DLC3.
 - (2) Turn the ignition switch to the ON position.
 - (3) Clear the DTCs following the prompts on the tester screen.

HINT:

Refer to the intelligent tester operator's manual for further details.

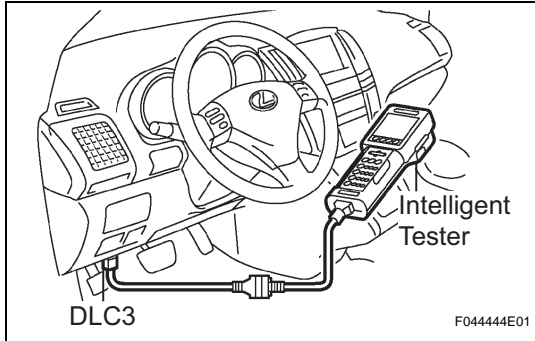

11. DATA LIST

HINT:

By accessing the ABS DATA LIST displayed by the intelligent tester, you can read the value of the switches and sensors without removing any parts. Reading the DATA LIST is the first step of troubleshooting is one method to shorten labor time.

- (a) Connect the intelligent tester to DLC3.
- (b) Turn the ignition switch to the ON position.
- (c) Following the display on the tester, select the ABS "DATA LIST".

ABS:

Item	Measurement Item / Range (Display)	Normal Condition	Diagnostic Note
STOP LIGHT SW	Stop light switch / ON or OFF	ON: Brake pedal depressed OFF: Brake pedal released	-
WHEEL SPD FR	Front right wheel speed reading / min.: 0 km/h (0 mph) max.: 326 km/h (202 mph)	Actual wheel speed	Speed indicated on speedometer
WHEEL SPD FL	Front left wheel speed reading / min.: 0 km/h (0 mph) max.: 326 km/h (202 mph)	Actual wheel speed	Speed indicated on speedometer
WHEEL SPD RR	Rear right wheel speed reading / min.: 0 km/h (0 mph) max.: 326 km/h (202 mph)	Actual wheel speed	Speed indicated on speedometer
WHEEL SPD RL	Rear left wheel speed reading / min.: 0 km/h (0 mph) max.: 326 km/h (202 mph)	Actual wheel speed	Speed indicated on speedometer
VEHICLE SPD	Vehicle speed reading / min.: 0 km/h (0 mph) max.: 255 km/h (158 mph)	Actual vehicle speed	Speed indicated on speedometer
EFI COM	EFI communication open detection / Normal or Open	Normal	-

Item	Measurement Item / Range (Display)	Normal Condition	Diagnostic Note
TEST MODE	Test mode / NORMAL or TEST	NORMAL: Normal mode TEST: During test mode	-
#CODES	Number of DTC recorded / min.: 0, max.: 255	Min.: 0, Max.: -	-

12. ACTIVE TEST LIST

HINT:

Perform the ACTIVE TEST using the intelligent tester to operate the ABS and tire pressure warning lights.

Performing the ACTIVE TEST is one of the methods to shorten labor time. It is possible to display the DATA LIST during the ACTIVE TEST.

- (a) Connect the intelligent tester to DLC3.
- (b) Turn the ignition switch to the ON position.
- (c) Following the display on tester, perform the "ACTIVE TEST".

ABS:

Item	Vehicle Condition / Test Details	Diagnostic Note
ABS WARN LIGHT	ABS warning light / ON or OFF	-

METER:

Item	Vehicle Condition / Test Details	Diagnostic Note
TIRE PRESS WARN LIGHT	Tire pressure warning light / ON or OFF	-