

Adjustment Data

MAZDA - 323 - 1.8i 16V - BP

Engine (general)

Item	Values	Units
Engine code	BP	
Capacity	1840	(cc)
Idle speed	1000 ± 50	(rpm)
Valve clearance		
Hydraulic		
Compression pressure		
Normal	12.8	(bar)
Minimum		(bar)
Oil pressure	3.4 - 4.4/3000	(bar / rpm)
Fuel system (make & type)	Mazda VICS L-Jetronic	
Adjustment screws (A = idle speed B = CO)	B	

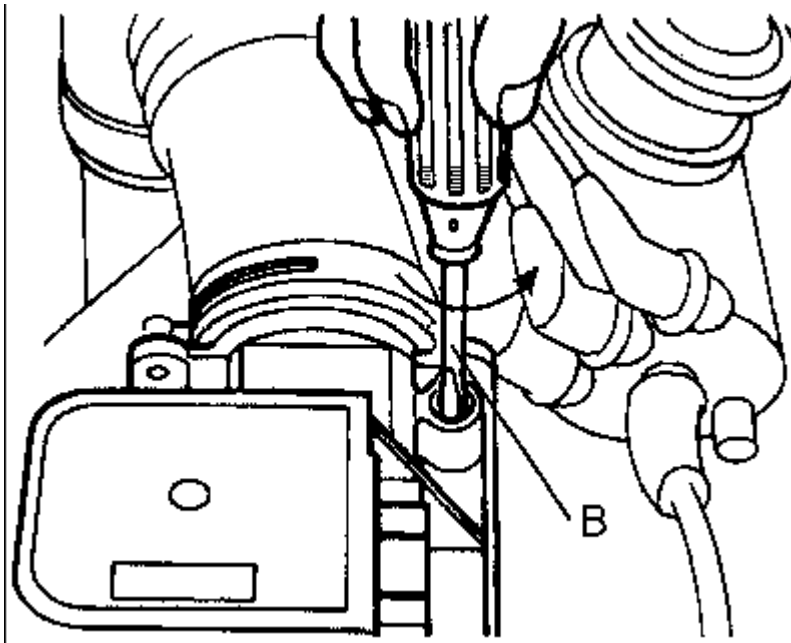

Firing order	1-3-4-2	
Timing stroboscopic (before TDC)	10 ± 1/1000	(° / rpm)
Ignition-coil resistance, primary	0.81 - 0.99	(ohms)
Ignition-coil resistance, secondary	10000 - 16000	(ohms)
Spark plugs (make & type)	NGK BKR6E11 Champion RC9YCC4	
Spark-plug gap	1.0 - 1.1	(mm)
Fuel-pump pressure	4.5 - 6.0	(bar)
Injection pressure / system pressure	2.7 - 3.2	(bar)
CO exhaust gas	< 0.5	(%)
CO2	14.5 - 16.0	(%)
HC	100	(ppm)
O2	0.1 - 0.5	(%)
Lambda	0.97-1.03	

Lambda change (Delta Lambda)	0.03	
Oil temperature during test	60	(°C)
Fast-idle speed	2500-2800	(rpm)
CO at fast-idle speed	< 0.3	(%)

Cooling system

Item	Values	Units
Cap pressure	0.75 - 1.05	(bar)
Thermostat opens at	84 - 89	(°C)
Fan on at	97	(°C)

Electrical

Item	Values	Units
Battery	80	(Ah)
Alternator	65	(A)

Brakes

Item	Values	Units
Disc thickness, front, min.	20	(mm)
Disc thickness, rear, min.	8.0	(mm)

Steering and wheel alignment

Item	Values	Units
Toe-in, front	2 ± 4	(mm)
Camber, front	-44' ± 1°	(°)
Castor, front	1° 55' ± 1°	(°)
K.P.I., front	13° 22'	(°)
Toe-in, rear	2 ± 4	(mm)
Camber, rear	-49' ± 1°	(°)

Wheels and tyres

Item	Values	Units
Tyre size	185/60R14	
Front tyre pressure	2.0	(bar)
Rear tyre pressure	1.8	(bar)

Capacities

Item	Values	Units
Engine sump, incl. filter	3.6	(l)
Manual transmission		
Gearbox refill	2.7	(l)
Automatic transmission		
Gearbox refill	4.9	(l)
Differential	0.8	(l)
Cooling system	6.0	(l)

Air-conditioner refrigerant	700 - 750	(g)
Air-conditioner compressor oil	150	(ml)

Torque settings

Item	Values	Units
------	--------	-------

Cylinder head

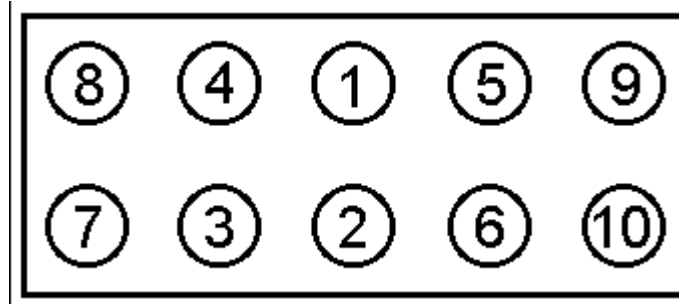

Stage 1	20 - 30	(Nm)
Stage 2	40 - 60	(Nm)
Stage 3	76 - 81	(Nm)
Front hub	235 - 319	(Nm)
Rear hub	177 - 235	(Nm)
Wheel nuts	118	(Nm)
Spark plugs	15 - 22	(Nm)

General information

- Electronic control unit (ECU) incorporates self-diagnosis function.
- ABS warning lamp will illuminate in the event of system failure.
- Trouble codes can be accessed with suitable code reader or a voltmeter connected to the data link connector (DLC) or diagnostic socket [Fig. 1](#) .
- For DLC or diagnostic socket location refer to System layout and components.

Accessing trouble codes

- Ensure ignition switched OFF.
- Bridge data link connector (DLC) terminals TBS and GND [Fig. 2](#) .
- Connect analogue voltmeter between data link connector (DLC) terminal FBS and vehicle battery [Fig. 2](#) .
- Switch ignition ON.
- Voltmeter needle will deflect to indicate trouble code(s).
- After a 3 second deflection the voltmeter indicates trouble code(s).
- A 1,2 second deflection indicates the 'tens' of the trouble code [Fig. 3](#) [A].
- A 0,4 second deflection indicates the 'units' of the trouble code [Fig. 3](#) [D].
- A 0,4 second pause separates each deflection [Fig. 3](#) [B].
- A 1 second pause separates the 'tens' and 'units' [Fig. 3](#) [C].
- A 4 second pause separates each trouble code [Fig. 3](#) [E].
- For example: Trouble code 22 displayed [Fig. 3](#) .
- Count voltmeter needle deflections.
- Compare with trouble code table.
- Switch ignition OFF.
- Remove bridge wire and voltmeter.

Erasing trouble codes

- Ensure ignition switched OFF.
- Bridge data link connector (DLC) terminals TBS and GND [Fig. 2](#) .
- Connect analogue voltmeter between data link connector (DLC) terminal FBS and vehicle battery [Fig. 2](#) .
- Switch ignition ON.
- Any stored trouble codes should be indicated.
- Depress and release brake pedal 10 times within 10 seconds.
- Warning lamp will illuminate for 2-3 seconds.
- Lamp extinguishes.
- Switch ignition OFF.
- Remove bridge wire and voltmeter.

Trouble code identification

Trouble code	Fault location
11	Wheel speed sensor, right front
12	Wheel speed sensor, left front
13	Wheel speed sensor, right rear
14	Wheel speed sensor, left rear
15	Wheel speed sensors
22	Solenoid valve, RH front
24	Solenoid valve, LH front
26	Solenoid valve, RH rear
28	Solenoid valve, LH rear
51	System relay
53	Pump motor
53	Pump motor relay
	Electronic control unit (ECU)

ABS warning lamp

Correct operating sequence

- Switch ignition ON.
- Lamp illuminates.
- Start engine.
- Lamp extinguishes after 3 seconds.

General test procedures

NOTE: Due to small size of ECU harness multi-plug pins it is advisable to use a breakout box.

Warning lamp circuit

Checking - Fig. 4

- Switch ignition ON.
- Check warning lamp illuminates.
- If not: Switch ignition OFF.
- Check fuses.
- Remove relay module.
- Disconnect ECU multi-plugs.
- Connect breakout box to 18-pin harness multi-plug.
- Bridge breakout box terminal 2L and earth.
- Switch ignition ON.
- Check warning lamp illuminates.
- If not: Switch ignition OFF.
- Check wiring and bulb.

Wheel speed sensors

Preparatory conditions

- Check wheel bearings for excessive play. Adjust or replace as necessary.
- Check wheel speed sensors for mechanical security.
- Inspect wheel speed sensor toothed rings visually for damaged teeth and cleanliness.

Checking

Technical Data	
Air gap	Not specified
Tightening torque	19-25 Nm

- No adjustment of wheel speed sensor air gaps is possible.
- If removed or replaced: Tighten fixing to specified torque.

Checking resistance - front - Fig. 5 & Fig. 6

Technical Data		
Terminals	Wheel speed sensor	Resistance
2O & 2P	Left hand	1600-2000 Ω
2N & 2M	Right hand	1600-2000 Ω

- Ensure ignition switched OFF.
- Disconnect ECU multi-plugs.
- Connect breakout box to 18-pin harness multi-plug.
- Check resistance between breakout box terminals [Fig. 5](#) .
- If resistance not as specified:
- Disconnect relevant wheel speed sensor multi-plug.
- Check resistance between wheel speed sensor terminals [Fig. 6](#) .
- If resistance as specified: Check wiring.
- If resistance not as specified: Suspect faulty wheel speed sensor.
- Repeat test for other wheel speed sensor.

Checking resistance - rear - [Fig. 5](#) & [Fig. 6](#)

Technical Data		
Terminals	Wheel speed sensor	Resistance
2R & 2Q	Left hand	1600-2000 Ω
2S & 2T	Right hand	1600-2000 Ω

- Ensure ignition switched OFF.
- Disconnect ECU multi-plugs.
- Connect breakout box to 18-pin harness multi-plug.
- Check resistance between breakout box terminals [Fig. 5](#) .
- If resistance not as specified:
- Disconnect relevant wheel speed sensor multi-plug.
- Check resistance between wheel speed sensor terminals [Fig. 6](#) .
- If resistance as specified: Check wiring.
- If resistance not as specified: Suspect faulty wheel speed sensor.
- Repeat test for other wheel speed sensor.

Checking voltage - front - [Fig. 7](#) & [Fig. 8](#)

Technical Data		
Terminals	Wheel speed sensor	Voltage
2O & 2P	Left hand	0,25-3,0 V ac
2N & 2M	Right hand	0,25-3,0 V ac

- Ensure ignition switched OFF.
- Raise vehicle.
- Disconnect ECU multi-plugs.
- Connect breakout box to 18-pin harness multi-plug.
- Adjust voltmeter to measure alternating current.
- Turn road wheel at 60 rpm.
- Check voltage between breakout box terminals [Fig. 7](#) .
- If voltage not as specified:
- Disconnect relevant wheel speed sensor multi-plug.
- Turn road wheel at 60 rpm.
- Check voltage between wheel speed sensor terminals [Fig. 8](#) .
- If voltage as specified: Check wiring.
- If voltage not as specified: Suspect faulty wheel speed sensor.
- Repeat test for other wheel speed sensor.

Checking voltage - rear - [Fig. 7](#) & [Fig. 8](#)

Technical Data		
Terminals	Wheel speed sensor	Voltage
2R & 2Q	Left hand	0,25-3,0 V ac
2S & 2T	Right hand	0,25-3,0 V ac

- Ensure ignition switched OFF.
- Raise vehicle.
- Disconnect ECU multi-plugs.
- Connect breakout box to 18-pin harness multi-plug.
- Adjust voltmeter to measure alternating current.
- Turn road wheel at 60 rpm.
- Check voltage between breakout box terminals **Fig. 7** .
- If voltage not as specified:
- Disconnect relevant wheel speed sensor multi-plug.
- Turn road wheel at 60 rpm.
- Check voltage between wheel speed sensor terminals **Fig. 8** .
- If voltage as specified: Check wiring.
- If voltage not as specified: Suspect faulty wheel speed sensor.
- Repeat test for other wheel speed sensor.

Checking wave form - front - **Fig. 9**

Technical Data	
Terminals	Wheel speed sensor
2O & 2P	Left hand
2N & 2M	Right hand

- Ensure ignition switched OFF.
- Raise vehicle.
- Disconnect ECU multi-plugs.
- Connect breakout box to 18-pin harness multi-plug.
- Connect oscilloscope between breakout box terminals.
- Turn road wheel at approximately 60 rpm.
- Check wave form of wheel speed sensor.
- If wave form not as specified:
- Disconnect relevant wheel speed sensor multi-plug.
- Turn road wheel at approximately 60 rpm.
- Check wave form between wheel speed sensor terminals.
- If wave form as specified: Check wiring.
- If wave form not as specified: Suspect faulty wheel speed sensor.
- Repeat test for other wheel speed sensor.

Checking wave form - rear - **Fig. 9**

Technical Data	
Terminals	Wheel speed sensor
2R & 2Q	Left hand
2S & 2T	Right hand

- Ensure ignition switched OFF.
- Raise vehicle.
- Disconnect ECU multi-plugs.
- Connect breakout box to 18-pin harness multi-plug.
- Connect oscilloscope between breakout box terminals.
- Turn road wheel at approximately 60 rpm.

- Check wave form of wheel speed sensor.
- If wave form not as specified:
- Disconnect relevant wheel speed sensor multi-plug.
- Turn road wheel at approximately 60 rpm.
- Check wave form between wheel speed sensor terminals.
- If wave form as specified: Check wiring.
- If wave form not as specified: Suspect faulty wheel speed sensor.
- Repeat test for other wheel speed sensor.

Relay module

NOTE: Relay module incorporates system relay and pump motor relay.

Checking supply voltage - [Fig. 10](#)

Technical Data		
Terminals	Condition	Voltage
B & earth	Ignition OFF	Battery voltage
D & earth	Ignition ON	Battery voltage

- Ensure ignition switched OFF.
- Remove relay module.
- Check voltage between relay module base terminal and earth.
- Switch ignition ON.
- Check voltage between relay module base terminal and earth.
- If voltage not as specified: Check wiring and fuses.

Checking earth connection - [Fig. 10](#)

Technical Data	
Terminals	Resistance
A & earth	Zero

- Ensure ignition switched OFF.
- Remove relay module.
- Check resistance between relay module base terminal and earth.
- If resistance not as specified: Check wiring.

Checking operation - system relay contacts - [Fig. 11](#)

Technical Data		
Terminals	Condition	Resistance
A & E	Battery voltage disconnected	Zero
B & E	Battery voltage disconnected	∞
A & E	Battery voltage connected	∞
B & E	Battery voltage connected	Zero
Battery + to terminal D		
Battery - to terminal C		

NOTE: Ensure battery voltage supply is connected correctly. Otherwise relay module could be damaged.

- Ensure ignition switched OFF.
- Remove relay module.
- Check resistance between relay module terminals.
- Connect battery voltage supply to specified relay module terminals.
- Check resistance between relay module terminals.

Checking resistance - system relay contacts - Fig. 11

Technical Data	
Terminals	Resistance
C & D	60-100 Ω

- Ensure ignition switched OFF.
- Remove relay module.
- Check resistance between relay module terminals.

Checking operation - pump motor relay contacts - Fig. 12

Technical Data		
Terminals	Condition	Resistance
B & F	Battery voltage disconnected	∞
B & F	Battery voltage connected	Zero
Battery + to terminal E		
Battery - to terminal H		

NOTE: Ensure battery voltage supply is connected correctly. Otherwise relay module could be damaged.

- Ensure ignition switched OFF.
- Remove relay module.
- Check resistance between relay module terminals.
- Connect battery voltage supply to specified relay module terminals.
- Check resistance between relay module terminals.

Checking resistance - pump motor relay contacts - Fig. 12

Technical Data	
Terminals	Resistance
E & H	50-90 Ω

- Ensure ignition switched OFF.
- Remove relay module.
- Check resistance between relay module terminals.

Electronic control unit (ECU)

Checking supply voltage - Fig. 13

Technical Data	
Terminals	Voltage
1H & earth	Battery voltage

- Ensure ignition switched OFF.
- Disconnect ECU multi-plugs.
- Connect breakout box to ECU harness multi-plugs.
- Switch ignition ON.
- Check voltage between breakout box terminal and earth.

Checking earth connection - [Fig. 13](#)

Technical Data	
Terminals	Resistance
1E & earth	Zero
1F & earth	Zero

- Ensure ignition switched OFF.
- Disconnect ECU multi-plugs.
- Connect breakout box to ECU harness multi-plugs.
- Check resistance between breakout box terminals and earth.
- If resistance not as specified: Check wiring.

Hydraulic modulator solenoid valves

Checking - [Fig. 14](#)

Technical Data		
Terminals	Solenoid valve	Resistance
C & G	LH front	3 Ω approx.
D & H	RH front	3 Ω approx.
A & E	LH rear	3 Ω approx.
B & F	RH rear	3 Ω approx.

- Ensure ignition switched OFF.
- Disconnect hydraulic modulator 8-pin multi-plug.
- Check resistance between hydraulic modulator terminals.

Checking supply voltage - [Fig. 15](#)

Technical Data	
Terminals	Voltage
E & earth	Battery voltage
F & earth	Battery voltage
G & earth	Battery voltage
H & earth	Battery voltage

- Ensure ignition switched OFF.
- Disconnect hydraulic modulator 8-pin multi-plug.

- Switch ignition ON.
- Check voltage between harness multi-plug terminals and earth.

Pump motor

Checking resistance - Fig. 16

Technical Data	
Terminals	Resistance
A & B	1 Ω max.

- Ensure ignition switched OFF.
- Disconnect hydraulic modulator 2-pin multi-plug.
- Check resistance between hydraulic modulator terminals.

Checking operation - Fig. 17

NOTE: DO NOT allow pump motor to run for more than 2 seconds.

- Ensure ignition switched OFF.
- Disconnect ECU multi-plugs.
- Remove relay module.
- Bridge relay module base terminals B and F with a switched lead.
- Operate switch.
- Pump motor should run.
- If not: Suspect faulty pump motor.

Brake pedal position (BPP) switch

Checking - Fig. 18

Technical Data		
Terminals	Condition	Voltage
1M & earth	Pedal released	Zero
1M & earth	Pedal depressed	Battery voltage

- Ensure ignition switched OFF.
- Disconnect ECU multi-plugs.
- Connect breakout box to 12-pin harness multi-plug.
- Check voltage between breakout box terminal and earth.
- Depress brake pedal.
- Check voltage between breakout box terminal and earth.
- If voltage not as specified: Check wiring and fuses.

Hydraulic system

Bleeding

- Ensure ignition switched OFF.
- Ensure reservoir topped up to MAX.
- Bleed in sequence: RH rear, LH rear, RH front, LH front.
- Connect tube to bleed screw and immerse end in jar of clean fluid.
- Depress brake pedal firmly two or three times.
- Open bleed screw.
- Depress brake pedal fully.
- Close bleed screw. Tightening torque: 6,9-9,8 Nm (front), 5,9-8,8 Nm (rear).

- Allow brake pedal to return.
- Repeat process until fluid is air free.
- Maintain fluid level in reservoir during bleeding procedure.
- Top up reservoir to MAX.

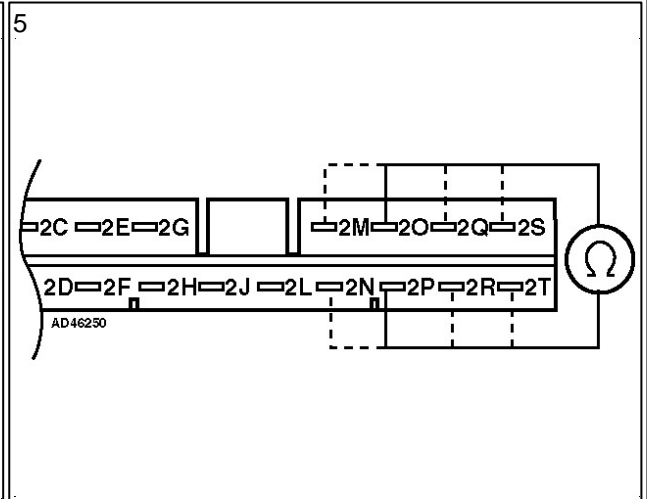
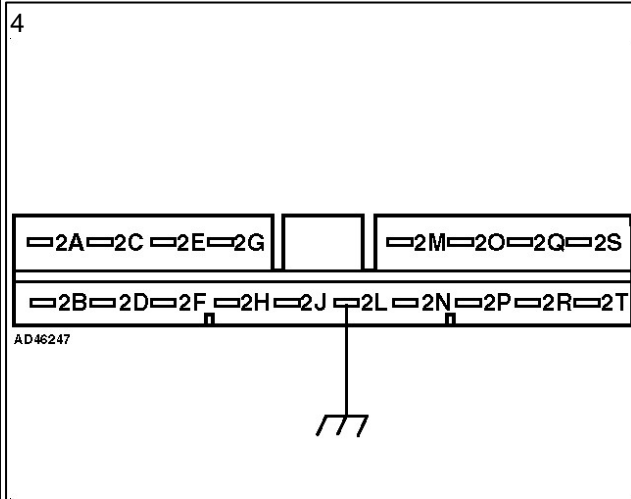
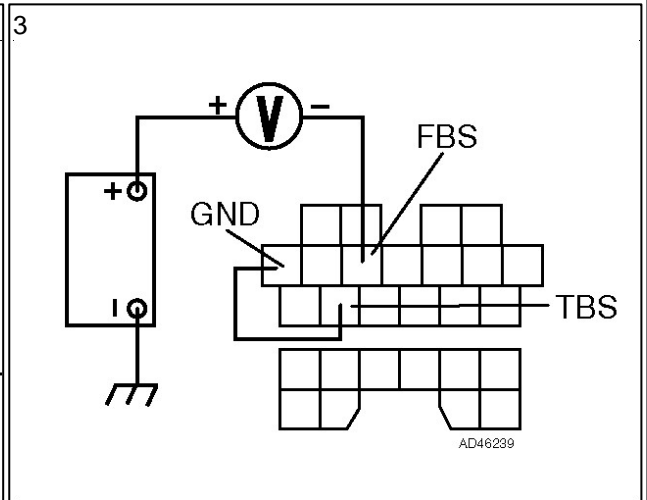
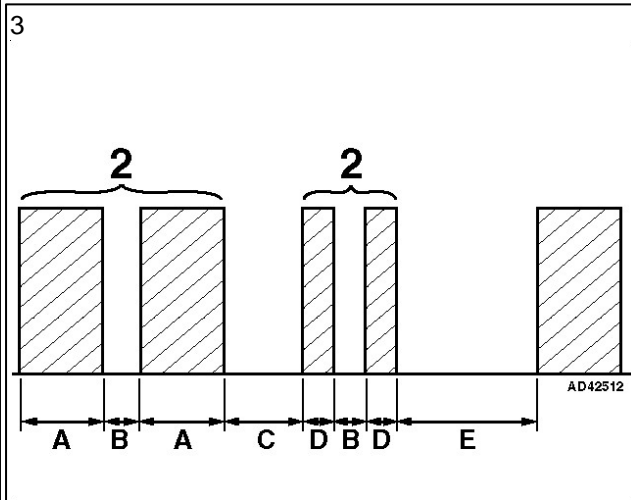
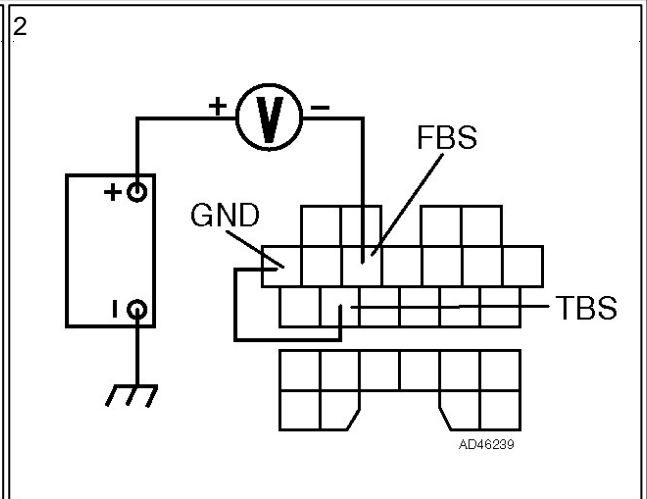
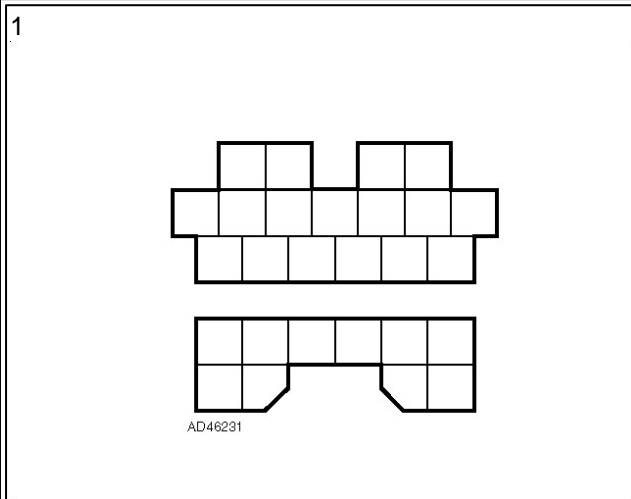

6



6

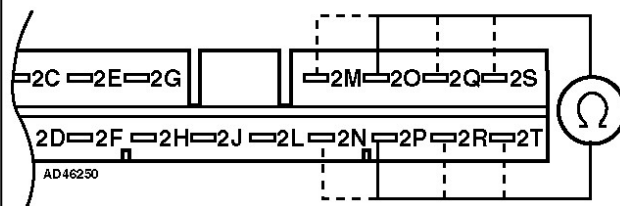

7

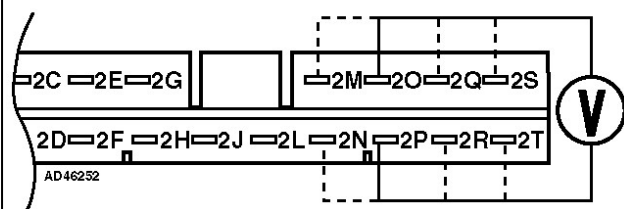

8

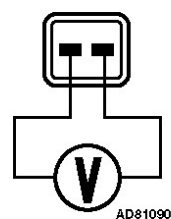

8

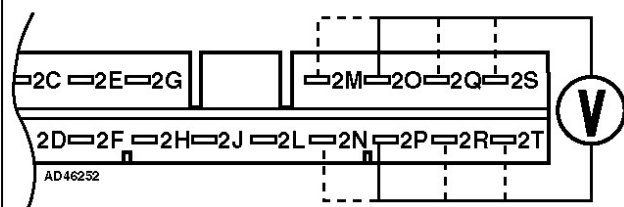

9

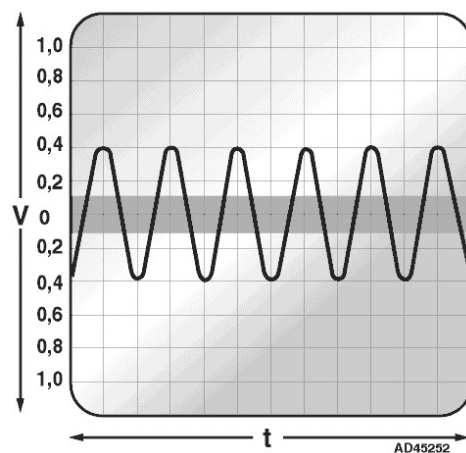

10

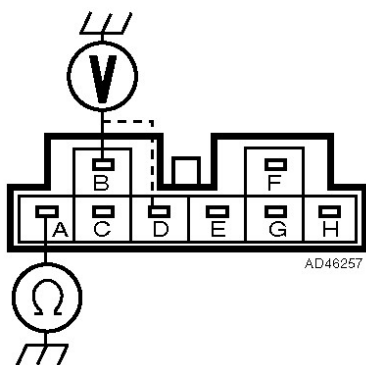

11

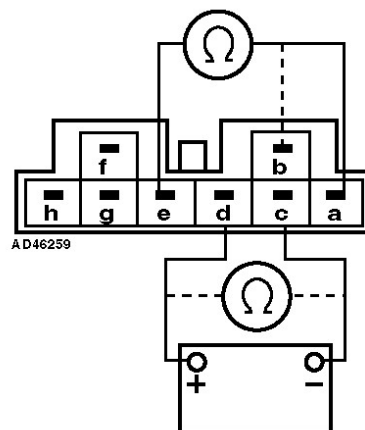

12

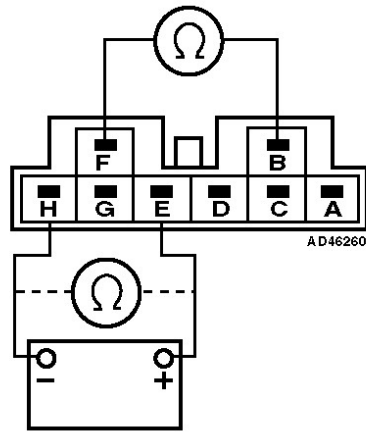

13

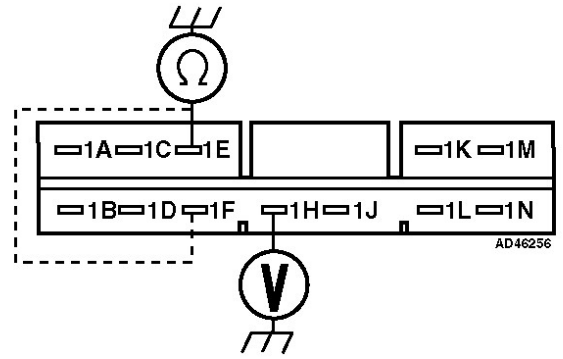

14

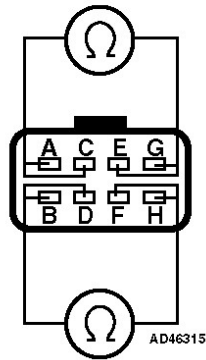

15

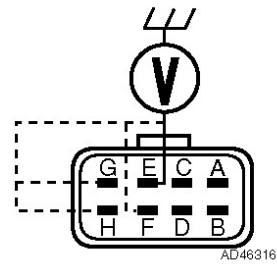

16

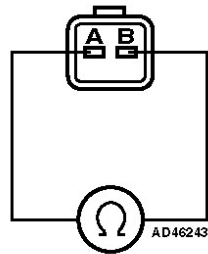

17

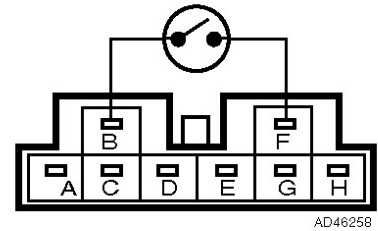

18

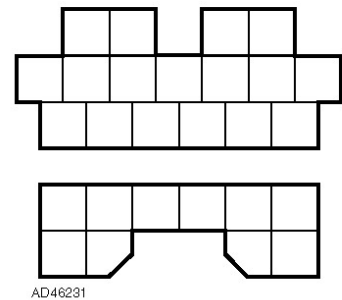

System description

- Optional driver's and front passenger's airbags.
- Airbag locations identified by the inscription 'SRS'.
- SRS control module mounted separately.
- Optional pyrotechnic pretensioners on front seat belts.

Special attention

- To prevent personal injury, expansion area of all airbags MUST remain clear.
- Steering wheel spiral cable has limited rotary movement.
- Centralise steering before disconnecting steering column. To prevent damage, ensure steering wheel and spiral cable DO NOT rotate before or during reassembly.
- Pyrotechnic pretensioners are electrically triggered by SRS control module.

SRS warning lamp

Operation

- Switch ignition ON.
- SRS warning lamp illuminates.
- If warning lamp does not illuminate: Suspect wiring or SRS warning lamp.
- Lamp extinguishes after approximately 4-8 seconds.
- If not: Suspect wiring or SRS control module.
- If warning lamp flashes:
- 3 flashes: Suspect open/short circuit or SRS control module.
- 6 flashes: Suspect driver's airbag.
- 7 flashes: Suspect passenger's airbag.

Disarm the system

When

- Fascia/instrument panel removal or replacement.
- Front seat belt removal or replacement.
- Front seat repair or replacement.
- Repair work around SRS components, especially airbags and pretensioners.
- SRS component removal or replacement.
- Steering wheel/column repair or replacement.
- Welding operations.

How

- Ensure ignition switched OFF.
- Disconnect battery earth lead. Make sure accidental reconnection is not possible.
- Disconnect SRS control module.
- Disconnect pyrotechnic pretensioners.

Arm the system

How

- Ensure ignition switched OFF.
- Reconnect SRS control module.

- Reconnect pyrotechnic pretensioners.
- Ensure vehicle interior is unoccupied.
- Reconnect battery earth lead.
- Switch ignition ON.
- Check SRS warning lamp operation.

After deployment

Check

- All mounting brackets for SRS components.
- Fascia/instrument panel.
- Seat assemblies.
- Seat belts, including buckles and anchorage points.
- Steering wheel and column.
- Surrounding components and trims.
- SRS wiring harness and multi-plugs for charred or damaged areas.

Renew

- All airbags.
- Fascia/instrument panel, if damaged.
- Front seat belts.
- Mounting brackets, if damaged.
- Seat components, if damaged.
- Spiral cable, if damaged or noisy.
- Steering column, if damaged.
- Steering wheel, if damaged.
- Surrounding components and trims, if damaged.
- SRS control module.
- SRS wiring harness and multi-plugs, if charred or damaged areas found.

Disposal

- Vehicle manufacturer suggests that deployed SRS components are sealed in a plastic bag and disposed of in accordance with local regulations.

Steering wheel removal and installation

Special attention

- Disarm system and remove driver's airbag.
- Centralise steering and disconnect spiral cable multi-plug before removing steering wheel.
- Spiral cable should not be allowed to rotate once steering wheel removed.
- To centralise spiral cable, slowly rotate clockwise until resistance is felt and then rotate approximately 2turns anti-clockwise until alignment marks aligned.
- Ensure spiral cable remains centralised during reassembly.

Steering wheel and airbag assembly [Fig. 1](#)

Spiral cable alignment marks [Fig. 2](#)

Tightening torques

Driver's airbag	8-12 Nm
Front passenger's airbag	16-22 Nm
Front seat	39-63 Nm
Front seat belt inertia reel	38-78 Nm
Front seat belt inertia reel bracket	18-26 Nm
Front seat belt buckle	39-78 Nm
Front seat belt upper anchorage point	38-78 Nm
Steering wheel	40-49 Nm
SRS control module	7-10 Nm

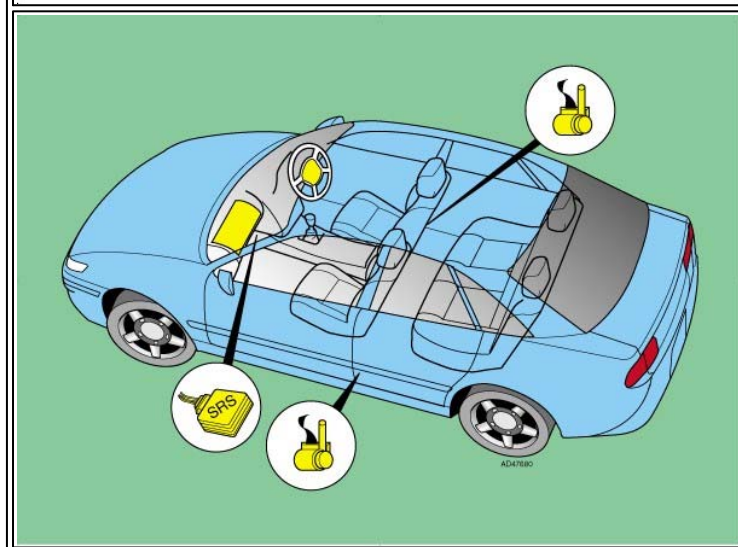
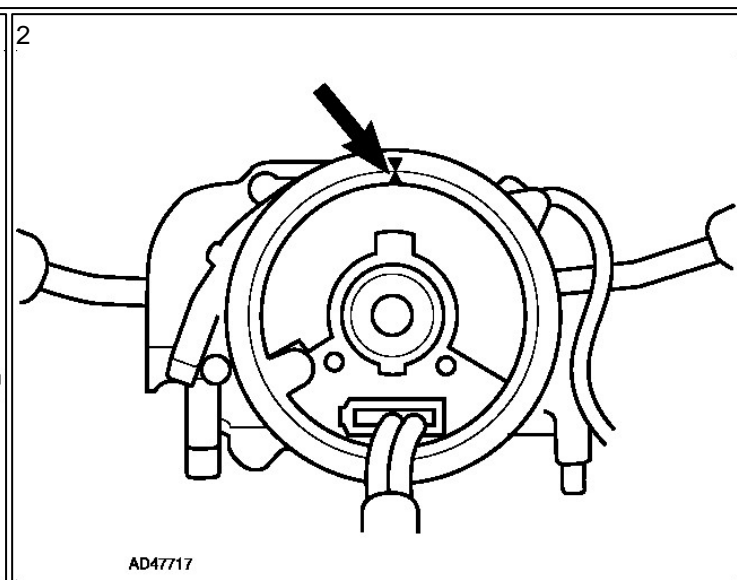
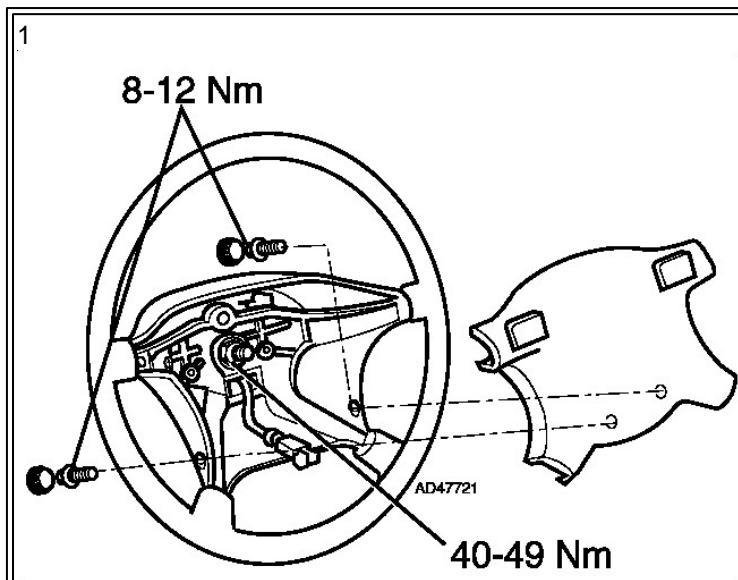

CANISTER PURGE SOLENOID

Function

The evaporative gases produced in the fuel tank are absorbed by the activated charcoal in the carbon canister. As the purge control solenoid valve opens, these gases are delivered to the intake manifold for combustion purposes. The purge control solenoid valve is controlled by the control unit. The control unit operates this valve during the time the lambda control loop is active.

Specifications

RESISTANCE:

resistance:	± 50 ohms
supply voltage:	12 Volts
current:	± 250 mA

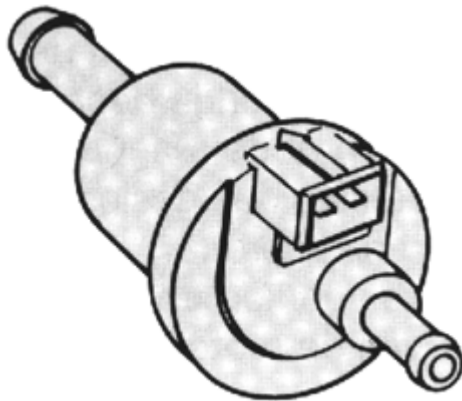

Electrical control

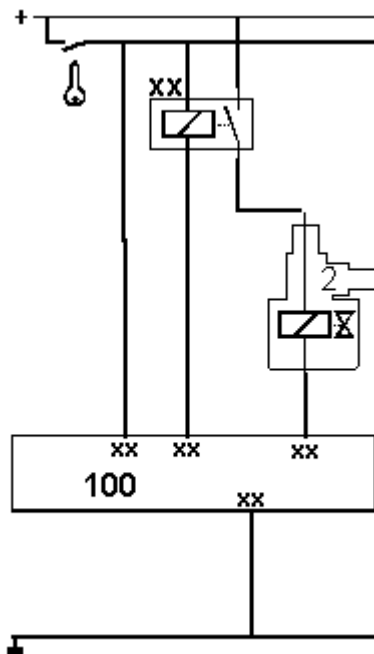

Most solenoids are normally closed. This means that the connection between the canister and the intake manifold is closed. The solenoid has a connector with two terminals. On one of those terminals is connected to the battery voltage. This supply-voltage is often switched with a relay. The other terminal leads directly to the control unit. The current through the solenoid is switched on during the time the control unit connects this terminal to ground. The voltage on this terminal is during this time 0 Volts. During the time the solenoid is switched off, the voltage on this terminal is 12 Volts. Some motormanagement systems control the amount of gases delivered to the intake manifold by switching the solenoid on and off with a certain duty cycle. In this case the duty-cycle depends on engine RPM and engine load.

Electrical diagnosis

STATIC

General

- To perform this measurements the relay switching the power to the solenoid should be closed. Short circuit the switch in the relay if necessary.

Measurements

- Measure the voltage on the control unit. Use the pin which switches the solenoid.

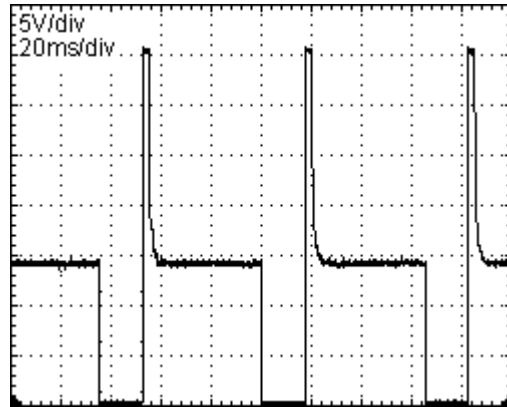

result: **12 V**

- solenoid and wiring are electrically OK

0 V

- check the relay switching the power to the solenoid
- check the wiring between the relay and the solenoid
- check the solenoid resistance
- check the wiring between the solenoid and the control unit
- check the control unit

Capacities

MAZDA - 323 - 1.8i 16V - BP

Item	Values	Units
Engine sump, incl. filter	3.6	(l)
Manual transmission		
Gearbox refill	2.7	(l)
Automatic transmission		
Gearbox refill	4.9	(l)
Differential	0.8	(l)
Cooling system	6.0	(l)
Air-conditioner refrigerant	700 - 750	(g)
Air-conditioner compressor oil	150	(ml)

© Copyright, Wessels + Müller AG

System information

Control system	Manual temperature control
System layout	Single evaporator - single zone
Refrigerant circuit type	Expansion valve

General information

Self-diagnosis

- No AC self-diagnosis function applicable to this model range.

System control

- Compressor operation controlled by refrigerant pressure switch.
- Compressor will not operate if refrigerant level is low.
- System incorporates an AC evaporator temperature sensor.

System repairs

- Access to evaporator housing from vehicle interior. Removal of fascia panel not required.
- Access to AC/heater blower motor from vehicle interior. Removal of fascia panel not required.

System service

- Refrigerant sight glass located in receiver/drier.
- Renew pollen filter every 36,000 miles or 48 months, whichever occurs first. [Fig. 1](#)

Refrigerant charging

NOTE: Running the engine with the high pressure service connector valve open is dangerous.

- Charging with vapour:
- Ensure refrigerant circuit is evacuated for a minimum of 15 minutes prior to charging.
- Charge via high pressure service connector.
- After 50% of refrigerant has entered system:
- Charge via low pressure service connector.
- Start engine.
- Air conditioning switched ON.
- Continue to charge until recommended quantity has entered system.

System fault diagnosis

- For information regarding system and component diagnosis refer to 'General test procedures' in the front section of this manual.

Fuse box/relay plates

Fascia [Fig. 2](#)

5-door

Fuse (Amps)	Circuit
F9 (10A) - 1,5	AC condenser blower motor relay, AC compressor clutch relay
F15 (10A) - except 2,0	AC amplifier, AC/heater function control panel, heater blower relay, AC/heater recirculation flap motor
F15 (10A) - 2,0	AC condenser blower motor relay, AC compressor clutch relay, AC amplifier, AC/heater function control panel, heater blower relay, AC/heater recirculation flap motor
F23 (40A) - → 10/96	AC/heater blower motor
F29 (15A)	AC/heater function control panel

→ 10/96 3/4-door

Fuse (Amps)	Circuit
F9 (10A)	AC condenser blower motor relay, AC compressor clutch relay
F15 (10A)	AC amplifier, AC/heater function control panel, heater blower relay, AC/heater recirculation flap motor
F23 (40A)	AC/heater blower motor

Fascia - 11/96 → 3/4-door [Fig. 3](#)

Fuse (Amps)	Circuit
F4 (15A)	AC amplifier, AC/heater function control panel, heater blower relay
F10 (10A)	AC condenser blower motor relay, AC compressor clutch relay
F11 (10A)	AC compressor clutch relay
F14 (15A) - 2,0TD	AC condenser blower motor relay II

Underbonnet [Fig. 4](#)

Fuse (Amps)	Circuit	
F4 (40A) - 11/96 →	AC/heater blower motor	
F4 (30A) - 5-door → 10/96	AC condenser blower motor relay I	
F9 (10A) - → 10/96	AC compressor clutch relay	
F9 (30A) - 11/96 →	AC condenser blower motor relay I	
F10 (30A) - 3/4-door → 10/96	AC condenser blower motor relay I	
F14 (30A) - 2,0TD	AC condenser blower motor relay II	
Location	Component	Circuit diagram code
2 - 11/96 →	Engine coolant blower motor relay	K12

Refrigerant pressures

Preparatory conditions

- Engine at normal operating temperature.
- Pollen filter installed and in good condition.

- All windows and doors closed.
- Ambient temperature above 15°C.
- Engine idling.
- Air conditioning switched ON.
- AC/heater blower motor switch set to position 4.
- AC/heater recirculation flap set to recirculation position.
- AC/heater temperature control(s) set to maximum cold position.
- Fascia ventilation outlets fully open.

Checking

- Run engine at 1500 rpm.

Ambient temperature	High pressure	Low pressure
15°C	10,3-11,4 bar	1,3-1,5 bar
20°C	11,7-12,7 bar	1,4-1,6 bar
25°C	13,1-14,9 bar	1,45-1,65 bar
30°C	15-17 bar	1,5-1,8 bar
35°C	16,5-19 bar	1,6-1,9 bar

Delivery temperature

Preparatory conditions

- Engine at normal operating temperature.
- Pollen filter installed and in good condition.
- Doors open.
- Engine idling.
- Air conditioning switched ON.
- Passenger compartment air temperature 15-40°C.
- Fascia ventilation outlets fully open.
- AC/heater blower motor switch set to position 4.
- AC/heater recirculation flap set to recirculation position.
- AC/heater temperature control(s) set to maximum cold position.

Checking

- Run engine at 1500 rpm.
- Measure ambient temperature in passenger footwell.
- Position temperature probe in fascia ventilation centre outlet.
- Wait for delivery temperature to stabilise.
- Measure temperature.

At 50% relative humidity

Ambient temperature	Delivery temperature
25°C	0-2°C
30°C	3-7°C
35°C	8-12°C
40°C	13-17°C

At 70% relative humidity

Ambient temperature	Delivery temperature
25°C	4-8°C
30°C	9-13°C
35°C	14-18°C
40°C	19-23°C

Technical data

Refrigerant	
Type	R134a
Type	Refer to engine bay label
Quantity - except 3HB/4SD 11/96 →	750 grams
Quantity - 3HB/4SD 11/96 →	700 grams

Refrigerant oil	
Type	Atmos GU10
Viscosity	ISO 46
Quantities:	
Compressor	Replace quantity drained + 10-20 ml
Condenser - 3/4-door	15 ml
Condenser - 5-door	30 ml
Evaporator - 3/4-door	50 ml
Evaporator - 5-door	60 ml
Line (general)	10 ml
Receiver/drier	10 ml
System - → 10/96	175 ml
System - 11/96 →	150 ml

Compressor clutch	
Adjustment type	Shim
Clearance	0,4-0,6 mm
Resistance	Not specified

AC evaporator temperature sensor	
Resistance	Not specified

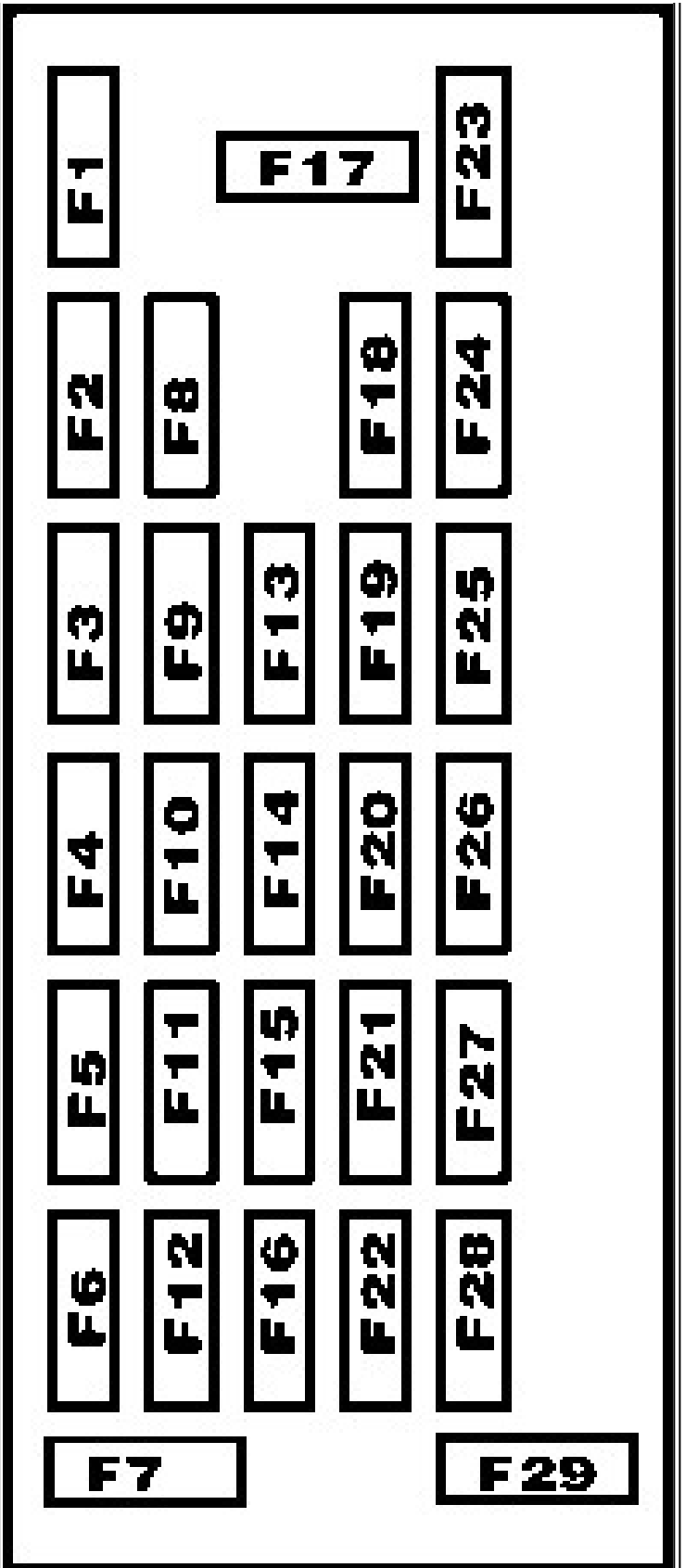

AD84819

3



AD49383

4

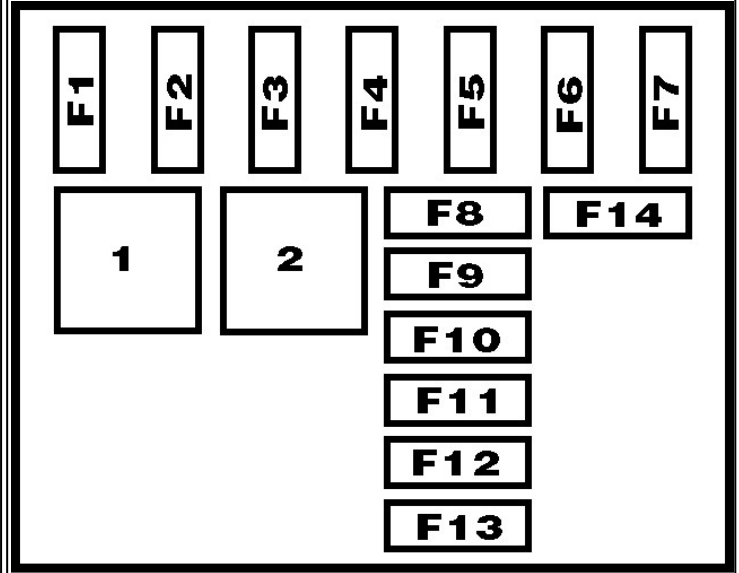

AD84821

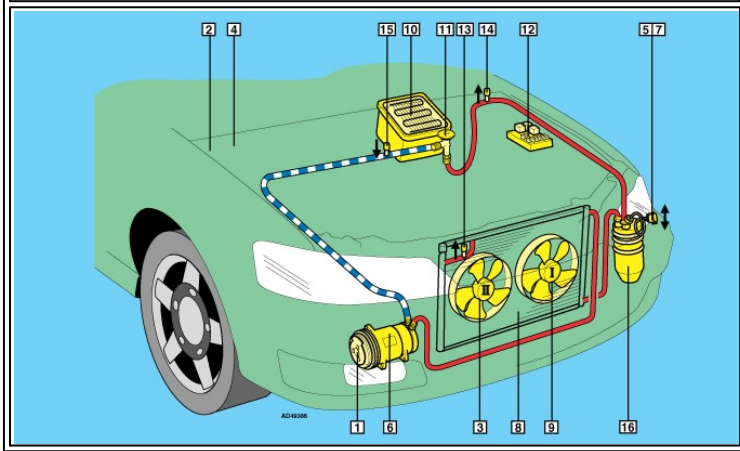

AD84821

Accessing trouble codes

- Ensure ignition switched OFF.
- Bridge data link connector (DLC) terminals GND and TEN **Fig. 1** .
- Connect LED test lamp between terminals FEN and B+ **Fig. 1** .

NOTE: Connect LED test lamp positive connection to DLC terminal B+.

- Switch ignition ON.
- Count LED flashes. Note trouble codes. Compare with trouble code table.
- Long flashes indicate the LH digit.
- Short flashes indicate the RH digit.
- Switch ignition OFF.
- The ECM fault memory can also be checked using suitable diagnostic equipment connected to the data link connector (DLC).

Erasing trouble codes

- Ensure ignition switched OFF.
- Disconnect battery earth lead.
- Depress brake pedal for 3 seconds.
- Reconnect battery earth lead.
- Repeat checking procedure to ensure no data remains in ECM fault memory.

WARNING: Disconnecting the battery may erase memory from electronic units (e.g. radio, clock).

Trouble code identification

Trouble code	Fault location
01	Ignition pulse
02	Engine speed (RPM) sensor/crankshaft position (CKP) sensor - Ne-signal
03	Camshaft position (CMP) sensor - G-signal
04	Camshaft position (CMP) sensor - G-signal
05	Knock sensor (KS)
06	Vehicle speed sensor (VSS)
08	Mass air flow (MAF) sensor/volume air flow (VAF) sensor
09	Engine coolant temperature (ECT) sensor
10	Intake air temperature (IAT) sensor
11	Intake air temperature (IAT) sensor
12	Throttle position (TP) sensor
14	Barometric pressure (BARO) sensor
15	Heated oxygen sensor (HO2S) - LH
16	Exhaust gas recirculation (EGR) sensor
17	Oxygen sensor (O2S)/heated oxygen sensor (HO2S)
23	Heated oxygen sensor (HO2S) - RH
24	Heated oxygen sensor (HO2S) - RH
25	Fuel pressure regulator control solenoid
26	Evaporative emission (EVAP) canister purge valve
28	Exhaust gas recirculation (EGR) solenoid - vacuum
29	Exhaust gas recirculation (EGR) solenoid - vent
34	Idle air control (IAC) valve
35	Fuel pressure regulator control solenoid 2

41	Intake manifold air control solenoid 1
46	Intake manifold air control solenoid 2
55	Speed sensor - AT torque converter
56	Temperature sensor - AT
60	Solenoid valve - 1-2 shift AT
61	Solenoid valve - 2-3 shift AT
62	Solenoid valve - 3-4 shift AT
63	Solenoid valve - lock-up AT
64	Solenoid valve - 3-2 shift AT
64	Engine coolant blower motor relay - K8-DOHC
65	Lock-up control solenoid valve (AT)
66	Line pressure solenoid (AT)
67	Engine coolant blower motor relay - 1/low temperature
68	Engine coolant blower motor relay - high temperature
69	Engine coolant blower motor temperature sensor

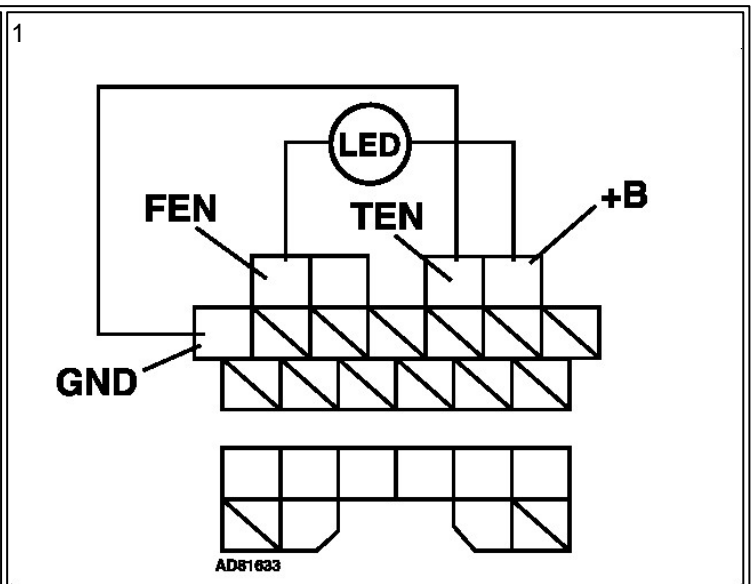
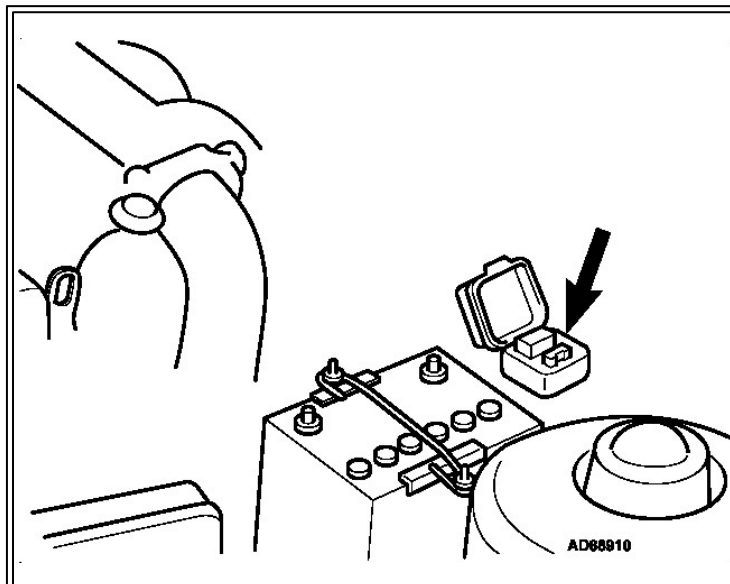

Environmental Data

MAZDA - 323 - 1.8i 16V - BP

Item	Values	Units
Engine code	BP	
Idle speed	1000 ± 50	(rpm)
Fuel system (make & type)	Mazda VICS L-Jetronic	
Adjustment screws (A = idle speed B = CO)	B	

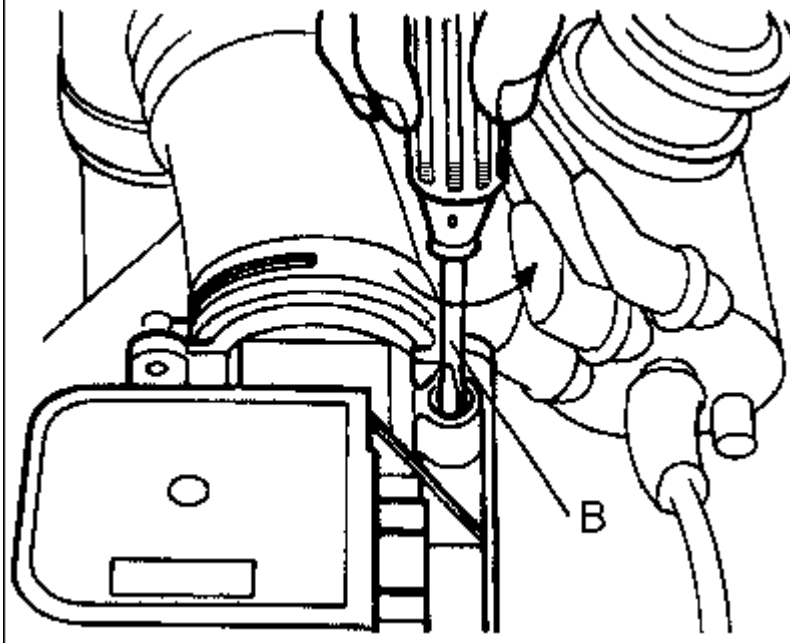

Timing stroboscopic (before TDC)	10 ± 1/1000	(° / rpm)
Fuel-pump pressure	4.5 - 6.0	(bar)
Injection pressure / system pressure	2.7 - 3.2	(bar)
CO exhaust gas	< 0.5	(%)
CO ₂	14.5 - 16.0	(%)
HC	100	(ppm)
O ₂	0.1 - 0.5	(%)
Lambda	0.97-1.03	
Lambda change (Delta Lambda)	0.03	
Oil temperature during test	60	(°C)
Fast-idle speed	2500-2800	(rpm)
CO at fast-idle speed	< 0.3	(%)

Notes			Specified value	Measured value
Vehicle identification				
	No. of cylinders	Type	4/DOHC	
	Capacity (Fiscal)	cc	1840	
	Compression ratio	:1	9,0	
	Suitable for unleaded petrol		Yes	
	Minimum octane rating	RON	91	
	Ignition system	Type	ESA	
	Ignition system	Description	Map-i	
	Trigger location		Distributor	
	Fuel system	Make	Mazda	
	Fuel System	Type	VICS	
	Fuel System	Description	MFI-s	
	Air metering	Type	Mass	
	Combined ignition and fuel ECM		Yes	
	Diagnostic socket		Yes	
Ignition system				
	Primary resistance	Ohm	0,49-0,73	
	Secondary resistance	Ohm	20000-31000	
	Firing order		1-3-4-2	
	Contact breaker gap/trigger air gap	mm	0,9	
Tuning and emissions				
7	Tuning conditions			
	Ignition timing - basic BTDC	°Engine/rpm	10±1/750	
	Ignition advance checks	°Engine/rpm	ECM Controlled	
	Idle speed	rpm	750±50	
	Oil temperature for CO test	°C	60	
	CO level at idle speed - tailpipe	Vol. % CO	0,5 Max Not adjustable	
	HC level at idle speed	ppm	100	
	CO2 level at idle speed	Vol. % CO2	14,5-16	
	O2 level at idle speed	Vol. % O2	0,1-0,5	
	Increased idle speed for CO test	rpm	2500-2800	
	CO content at increased idle speed	Vol. %	0,3	
	Lambda at increased idle	λ	0,97-1,03	
Spark plugs				
	Spark plugs	Original equipment	NGK	
	Spark plug	Type	BKR5E-11	
	Electrode gap	mm	1,1	
	Spark plugs	Make	Autolite	
	Spark plug	Type	APP3924	
	Electrode gap	mm	1,0	
	Spark plugs	Make	Beru	
	Spark plug	Type	14FR-7DUX	
	Electrode gap	mm	1,1	
	Spark plugs	Make	Bosch	
	Spark plug	Type	FR7DCX	
	Electrode gap	mm	1,1	
	Spark plugs	Make	Champion	
	Spark plug	Type	RC8YCC4	
	Electrode gap	mm	1,1	
	Spark plugs	Make	NGK	
	Spark plug	Type	BKR5E-11	
	Electrode gap	mm	1,1	
Fuel system				
	Fuel pump delivery pressure	bar	5,0-6,3	
	System pressure without vacuum	bar	2,8-3,1	
	Regulated pressure with vacuum	bar	2,0-2,4	

	Engine coolant temperature (ECT) sensor	Ohm/°C	300-400/80	
	Injector	Ohm	13,8	
	Idle speed control valve	Ohm	8,7-10,5	
	Oxygen sensor heater	Ohm	6	

Service checks and adjustments

78	Valve clearance -INLET	mm		
78	Valve clearance -EXHAUST	mm		
	Compression pressure	bar	9,6-12,8	
	Oil pressure	bar/rpm	4,4 Max	

Lubricants and capacities

	Engine oil grade - cold climate	SAE	5W/30	
	Engine oil grade - moderate climate	SAE	10W/30	
	Engine oil grade - hot climate	SAE	20W/40	
	Engine oil classification	API/ACEA	SJ/A2-96	
	Engine oil grade - alternative - moderate climate	SAE	10W/40	
	Engine oil classification - alternative - moderate climate	API/ACEA	SJ/A2-96	
	Engine with filter	litres	3,8	
	Gearbox oil grade	SAE	75W/90	
	Gearbox 4/5 speed	litres	2,7	
	Automatic transmission fluid	Type	Dexron II	
	Cooling system	litres	6,0	
	Brake fluid	Type	DOT 3/4	
	Power steering fluid	Type	Dexron II	
	Power steering fluid	litres	1,3-1,4	

Tightening torques

	Cylinder head instructions			
--	----------------------------	--	--	--

Cylinder head

		Renew bolts	No	
	Stage 1	Tighten	30 Nm	
	Stage 2	Tighten	55 Nm	
	Stage 3	Tighten	76-81 Nm	

Other tightening torques

	Main bearings	Renew bolts/nuts	No	
	Main bearings	Stage 1	30 Nm	
	Main bearings	Stage 2	54-58 Nm	
	Big end bearings	Renew bolts/nuts	No	
	Big end bearings	Stage 1	25 Nm	
	Big end bearings	Stage 2	48-50 Nm	
	Sump bolts		10 Nm	
	Sump drain bolt		30-40 Nm	
	Flywheel/driveplate		100 Nm/100 Nm	
	Clutch to flywheel		18-26 Nm	
	Crankshaft pulley/damper		157-166 Nm	
	Camshaft sprocket/gear		50-60 Nm	
	Camshaft carrier/cap		11-14 Nm	
	Camshaft/rocker cover		5-9 Nm	
	Inlet manifold to cylinder head		19-25 Nm	
	Exhaust manifold to cylinder head		39-46 Nm	
	Exhaust downpipe to manifold		38-51 Nm	
	Spark plugs		15-22 Nm	
	Oxygen sensor (Lambda)		30-49 Nm	
26	Front hub			
27	Rear hub			
	Steering track rod end		43-56 Nm	
	Brake caliper carrier to hub	Front	54 Nm	
	Brake caliper to carrier	Rear	53 Nm	
	Brake caliper carrier to hub	Rear	53 Nm	
	ABS sensor	Front	20 Nm	

	ABS sensor		Rear	20 Nm	
	Road wheels			89-127 Nm	
Starting and charging					
	Battery		V/RC(Ah)	12/50 (40)	
	Starter motor		Type	0,9/1,1 kW	
	Maximum cranking amps		A	108-132	
	Alternator/Regulator		Make	Mitsubishi	
	Alternator output at engine speed		A/V/rpm	80/14/2000	
	Regulated voltage		V	14,1-14,7	
Brake disc and drum dimensions					
	Minimum disc thickness - ventilated		Front	20 mm	
	Minimum disc thickness		Rear	8 mm	
	Disc runout		Front	0,10 mm	
	Disc runout		Rear	0,10 mm	
	Minimum pad thickness		Front	1 mm	
	Minimum pad thickness		Rear	1 mm	
	Minimum shoe thickness		Rear	1 mm	
	Handbrake travel		No. of notches	5-7	
Air conditioning					
	Air conditioning refrigerant		Type	R134a	
71	Air conditioning refrigerant quantity		grams	750	
	Air conditioning oil		Type	Atmos GU10	
51	Air conditioning oil quantity		cmi	175	

Cylinder layout

AD75043

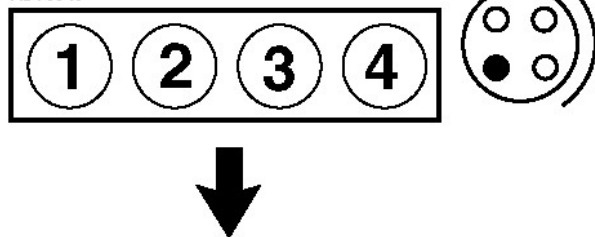

Timing mark

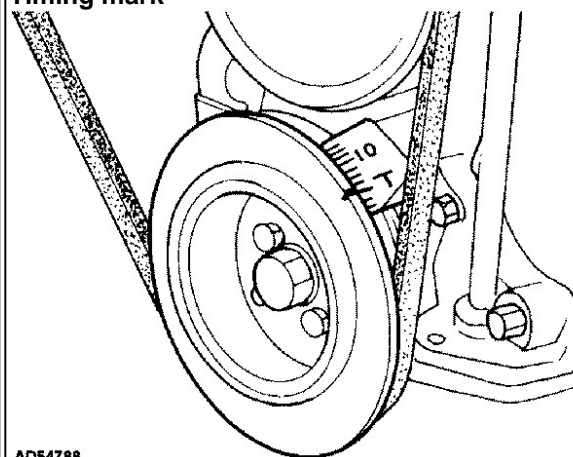

AD54788

Idle speed adjustment (A)

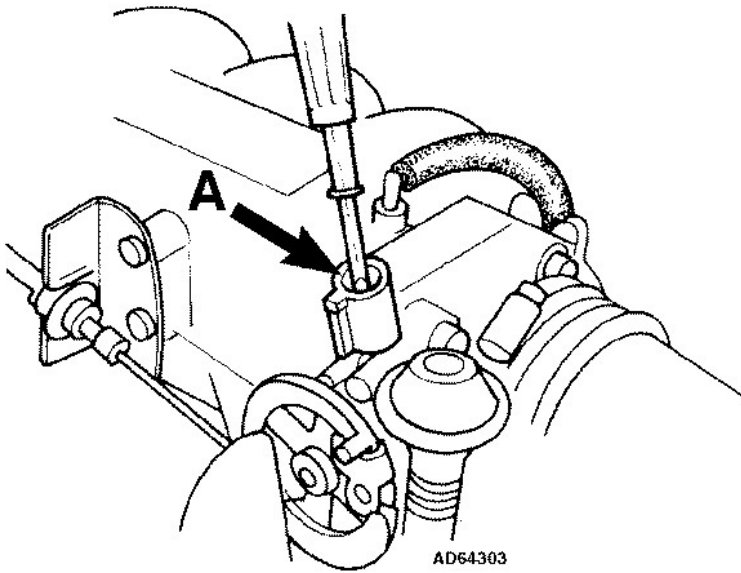

Tightening sequence

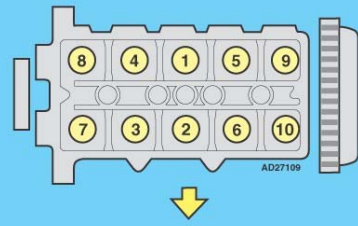

MAZDA - 323 - 1.8i 16V - BP

- 1 Identification plate
- 2 VIN
- 3 Engine code B3 / B5 / B6 / PN
- 4 Engine code BP / FP / FS
- 5 Manual transmission code

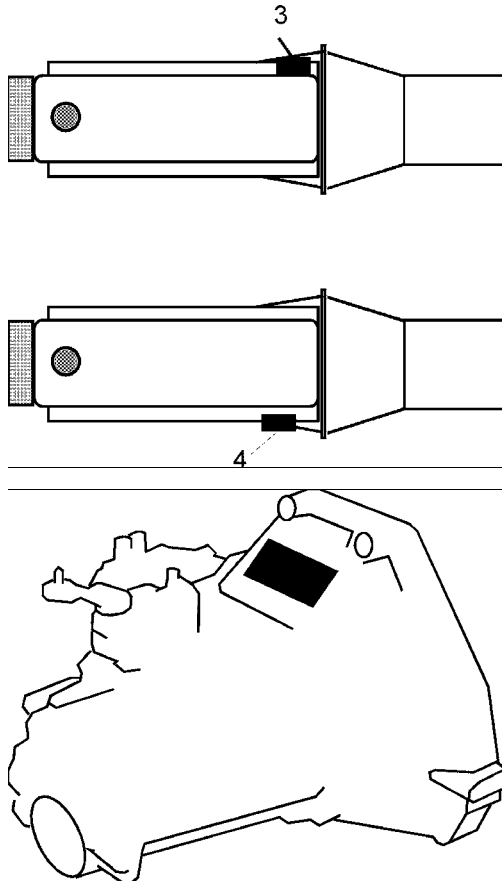

IDLE SPEED CONTROL VALVE

Function

The idle control valve is located in a tube bypassing the throttle. The control unit controls this device to ensure stable idling in all operating conditions.

Specifications

resistance coil(s):	± 20 ohms
supply voltage:	12 Volts

A rotary slide valve attached to the armature is turned to open the air bypass until the desired idle speed is obtained. The position of the armature is controlled by the force of an internal spring opposing the force of a solenoid (types with two terminals) or controlled by two solenoids energised alternately which exerts opposing forces on the armature (types with three terminals).

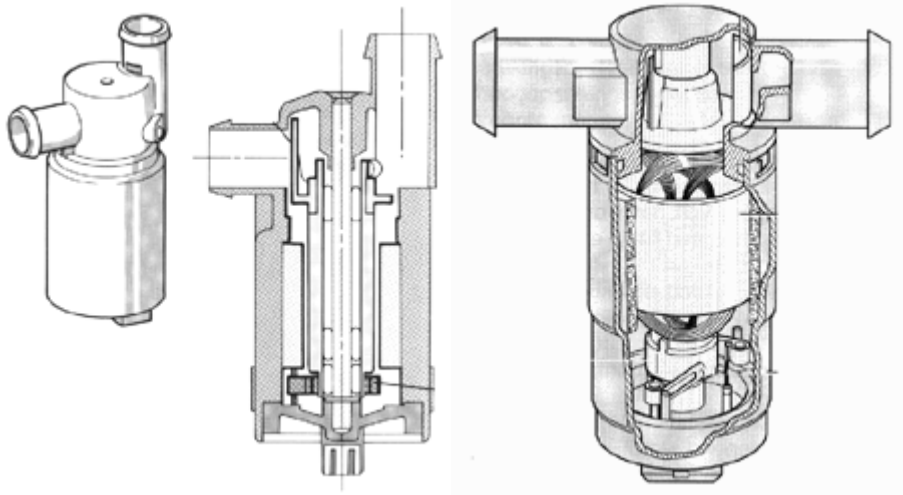

Electrical control

Types with two terminals

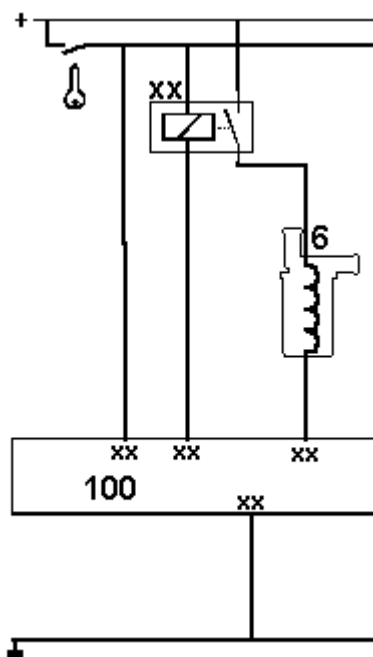

As a current flows through the coil the armature is turned against the spring force. As the current increases the airflow and the idle speed increases. If the current through the coil is switched off due to a malfunctioning system, the valve is forced into a position which results in a (too) high idle speed.

The idle control valve has a connector with two terminals. On one of those terminals is connected to the battery voltage. This supply-voltage is often switched with a relay. The other terminal leads directly to the control unit. The current through the coil is switched on during the time the control unit connects this terminal to ground. The voltage on this terminal is during this time 0 Volts. During the time the current through the coil is switched off, the voltage on this terminal is 12 Volts.

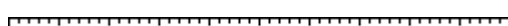

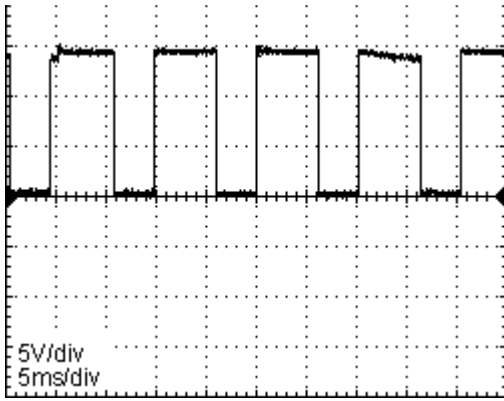

The control unit controls the current through the coil switching the current on and off with a certain duty cycle. The current increases as the duty-cycle increases. The duty cycle varies between approx. 35% (valve closed) and 85% (valve opened). Nominal idle speed is obtained when slightly open.

Three terminal types

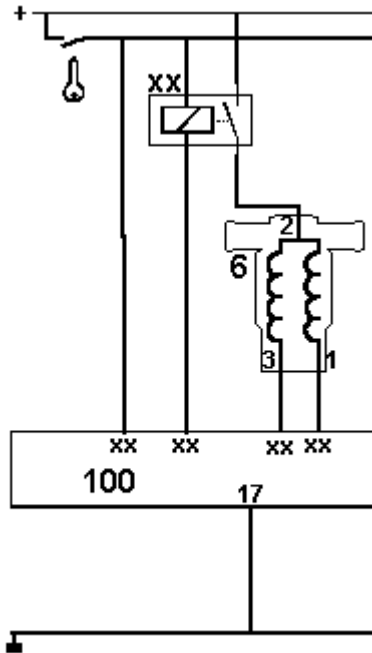

The two coils inside this type of idle speed control valve are connected with the supply voltage using one common terminal. The other two terminals lead directly to the control unit. The control unit switches the current through the solenoid on and off alternately with a duty cycle between 35 and 85%.

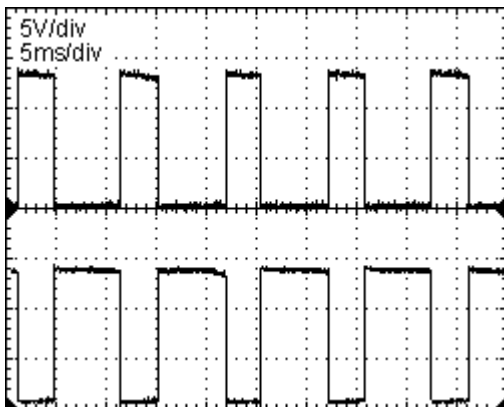

Electrical diagnosis

STATIC

- To perform this measurements the relay switching the power to the idle control valve should be closed. Short circuit the switch in the relay if necessary.

Measurements:

Disconnect the connector and

DYNAMIC TESTS THREE TERMINAL TYPES

- Remove the idle control valve but leave the electrical connections in place. Fully open or close the rotating plunger. Switch on the ignition.

measure the resistance of the coil(s). The nominal value is app. 20 ohms.

- Check the relay switching the power to the idle control valve
 - Check the wiring between the relay and the idle control valve
 - Check the wiring between the idle control valve and the control unit
 - Check the control unit
- result:
- Switch on the ignition. The rotating plunger must move to a position equivalent to app. 50% opening, and remain there.

Mechanical diagnosis

- Check the air chamber on air leakage.
- Check engine on air leaks into the intake system.
- Remove the idle control valve. The plunger should rotate or move easily. Clean if necessary.

IGNITION MODULE

Function

The ignition module switches the current through the primary ignition coil on and off. The ignition module charges the ignition coil during the time the current is switched on. The moment the ignition module switches the current 'off' the ignition coil induces an induction voltage which causes the spark.

An ignition module switches the current on and off according to an input signal. This input is delivered by the control unit. On older systems the input signal is delivered by an inductive, Hall or opto-coupled sensor mounted in the distributor.

Specifications

resistance	-
supply voltage	-

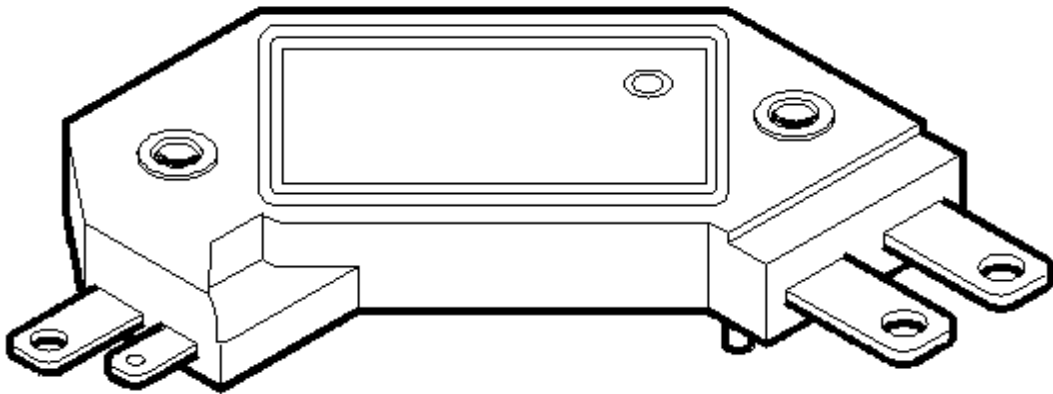

Electrical control

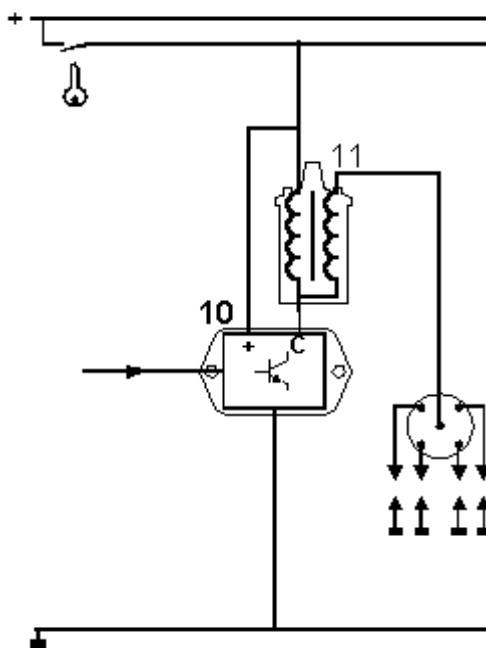

The connector of the ignition module has several terminals. The following terminals are used on common ignition modules.

- a terminal connected with the ignition coil. By this terminal the current through the ignition coil is switched on and of.
- a terminal connected with the supply voltage (12 Volts)
- a terminal connected with ground.
- terminal(s) to receive the input signal. If the input signal is delivered by an inductive sensor two terminals are needed.

The output voltage of an inductive sensor is delivered by an internal coil. This coil induces an almost sine wave output voltage. If the input signal is delivered by an Hall-sensor or opto-coupler three terminals are needed. Two of those three terminals are used to supply the sensor. The supply voltage is either 5 or 12 Volts. The third terminal receives the output signal from the sensor. The output voltage of these sensors is a square wave signal.

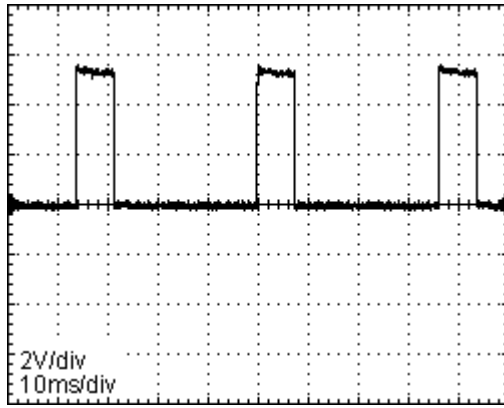

Addition terminals are possible. For example to send out a RPM signal to the revolution counter. Sometimes the input signal is delivered by a sensor while the ignition timing is controlled by the control unit. In this case the received input signal from the sensor is converted into a square wave signal by the ignition module and send out to the control unit. The control unit receiving this signal computes this input information and other input information from various engine parameters and sends out a new square wave signal to the ignition module. This signal is used by the ignition module to switch the current through the primary ignition coil on and off.

During the time the input signal for the ignition module is 'high' the current is switched 'on'. The moments this input signals falls to 'low' the current is switched 'off'. This moment the spark will appear

Electrical diagnosis

- Start the engine and measure (using an oscilloscope) the input signal delivered by the control unit or input sensor. The square wave signal or sine wave signal from a inductive sensor should be visible.
- signal not OK:
- Disconnect the ignition module's connector and check the wiring between the ignition module and the control unit or input sensor.
 - replace the ignition module if the signal appears on the disconnected connector and disappears on the connected connector.

If the output signal remains invisible the failure is not in the component.

- signal OK:
- check the power supply of the ignition module.
 - check the primary voltage using an ignition oscilloscope or normal oscilloscope with a suitable probe.
 - check the wiring between the ignition module and the ignition coil.

The voltage should be nearly 0 Volt during the period the ignition module receives an 'high' input voltage from the sensor or control unit.

Mechanical diagnosis

- Remove the auxiliary air valve without disconnecting the connector.
- Turn the ignition on and make sure that the valve closes as the heating element heats-up the bi-metallic strip.

MAZDA - 323 - 1.8i 16V - BP

Engine

Motor oil API SG	Below 0 °C	SAE 5W-30
Motor oil API SG	From -25 °C to 30 °C	SAE 10W-30
Motor oil API SG	Above -25 °C	SAE 10W-40
Motor oil API SG	Above -25 °C	SAE 10W-50
Motor oil API SG	Above -10 °C	SAE 20W-40
Motor oil API SG	Above -10 °C	SAE 20W-50

Cooling system

Coolant	All temperatures
---------	------------------

Manual transmission (2WD)

ATF Dexron II	All temperatures
ATF M-III	All temperatures

Manual transmission (4WD)

Gear oil API GL-4	All temperatures	SAE 75W-90
Gear oil API GL-5	All temperatures	SAE 75W-90
ATF Dexron II	All temperatures	

Automatic transmission

ATF Dexron II	All temperatures
ATF M-III	All temperatures

Transfer box

Gear oil API GL-5	Above -15 °C	SAE 90
Gear oil API GL-5	Below -1 °C	SAE 80W

Differential, rear (4WD)

Gear oil API GL-5	Above -15 °C	SAE 90
Gear oil API GL-5	Below -1 °C	SAE 80W

Power steering

ATF Dexron II	All temperatures
ATF M-III	All temperatures

Brakes system

Brake fluid DOT 3	All temperatures
-------------------	------------------

Air conditioning

Refrigerant R134a
Compressor oil PAG, ISO 46

Timing

MAZDA - 323 - 1.8i 16V - BP

General

Item

Always check the timing marks before timing belt removal

Note

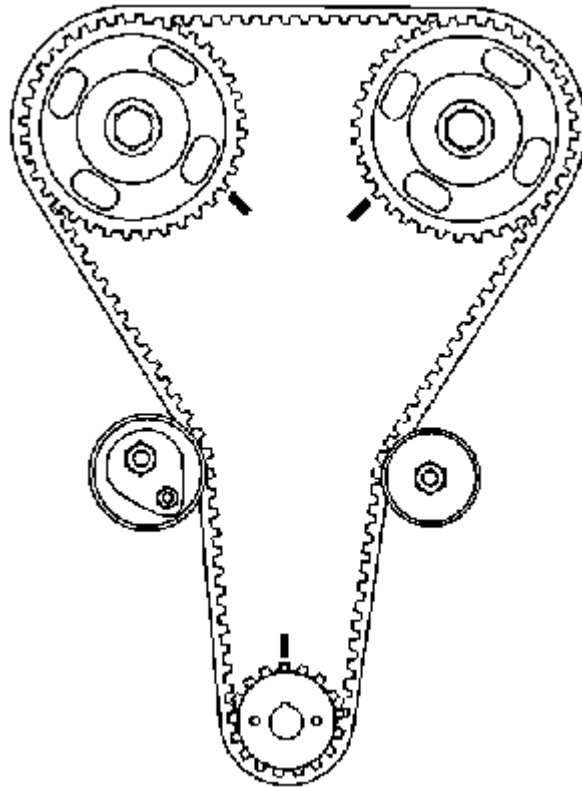

Before disconnecting the battery cable, check the audio system security code

Removal

Item

- Disconnect the battery
- Remove the right front wheel
- Remove the lower cover

Note

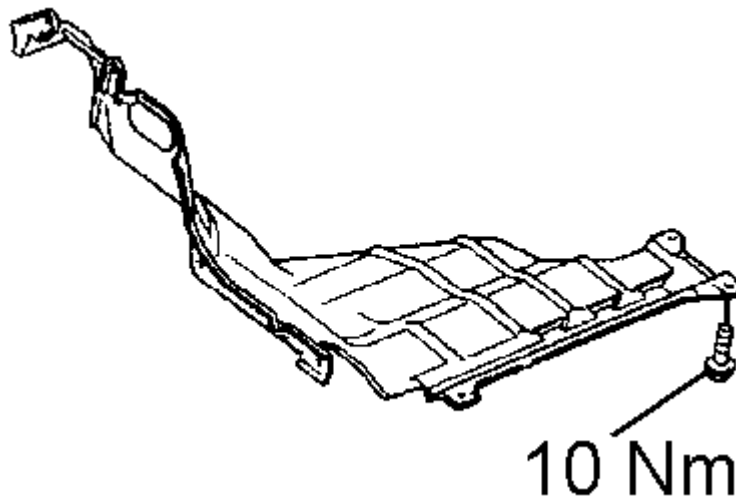

- Remove the ancillary drive belt
- Remove the water pump pulley

- Disconnect the spark-plug leads
- Remove the spark plugs
- Remove the dipstick
- Remove the camshaft cover

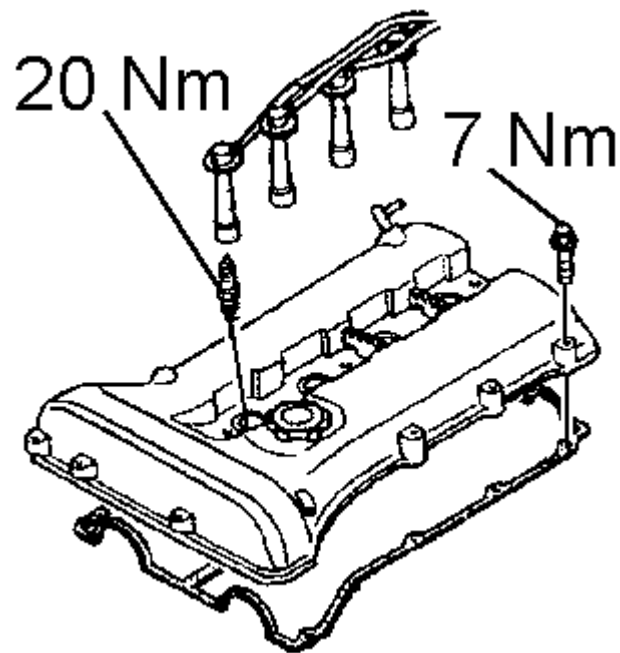

- Remove the timing-belt covers

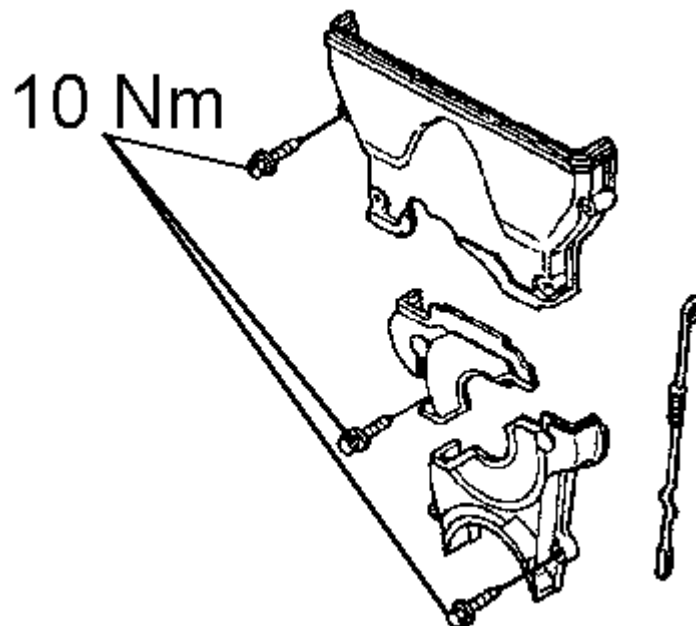

- Remove the crankshaft pulley

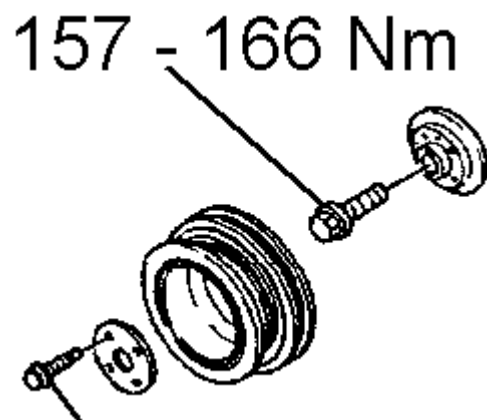

15` Nm

Use a special tool:

49 D011 102

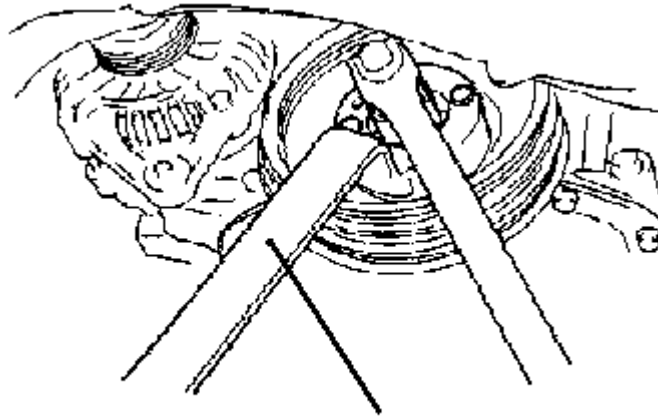

49 D011 102

Turn the crankshaft clockwise to align the timing marks

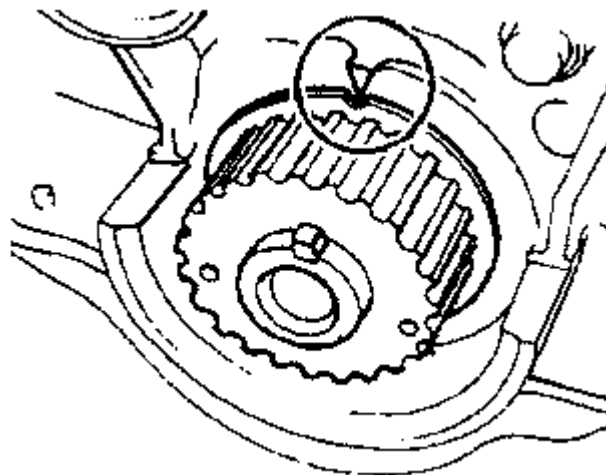
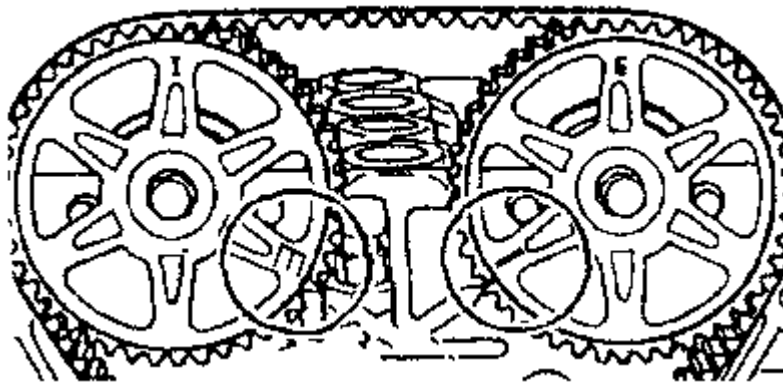

Loosen the tensioner

Push the tensioner pulley away from the timing belt

Tighten the tensioner

Remove the timing belt

Installation

Item

Check the timing marks

Note

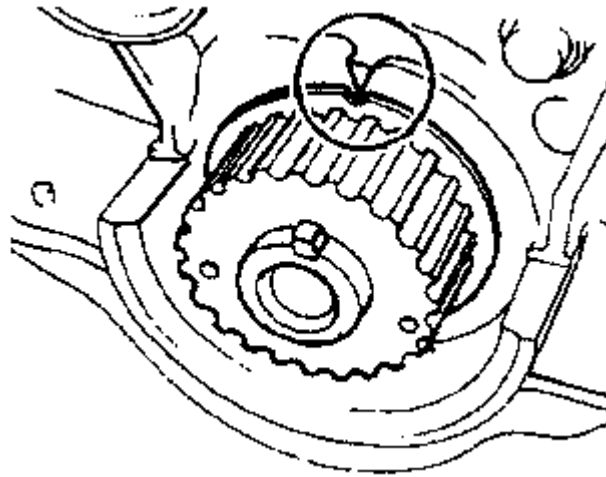
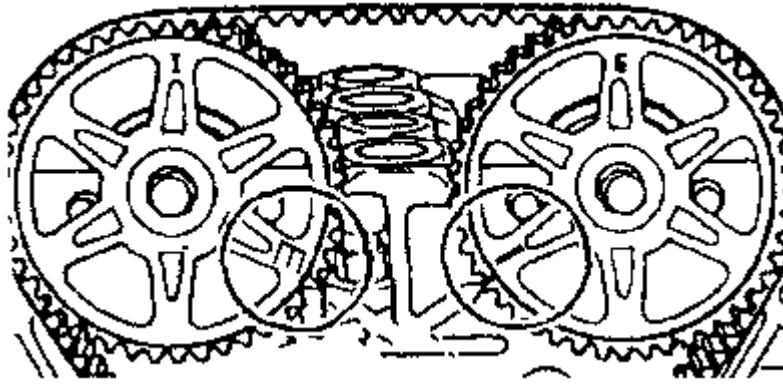

- Fit the timing belt
- Turn the engine 2 rotations by hand
- Check the timing marks
- Turn the engine $1 \frac{5}{6}$ times by hand

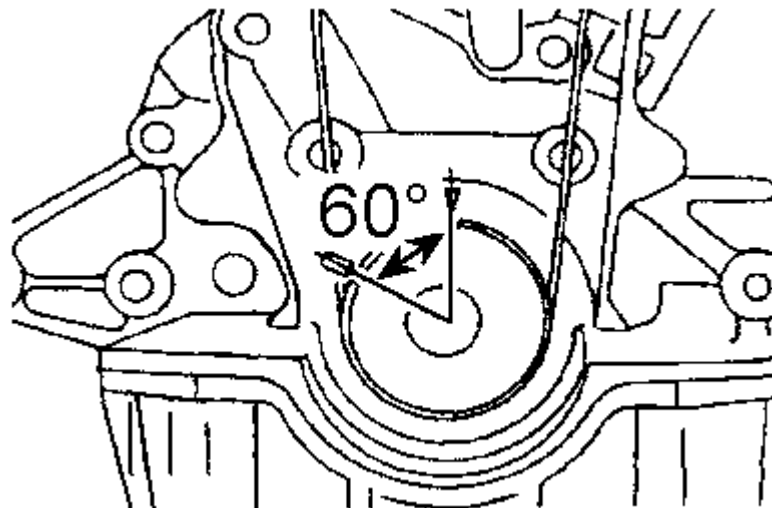

- Loosen the tensioner
- Tighten the tensioner
- Turn the engine $2 \frac{1}{6}$ revolutions
- Check the timing marks
- Measure the timing belt deflection

98 Nm



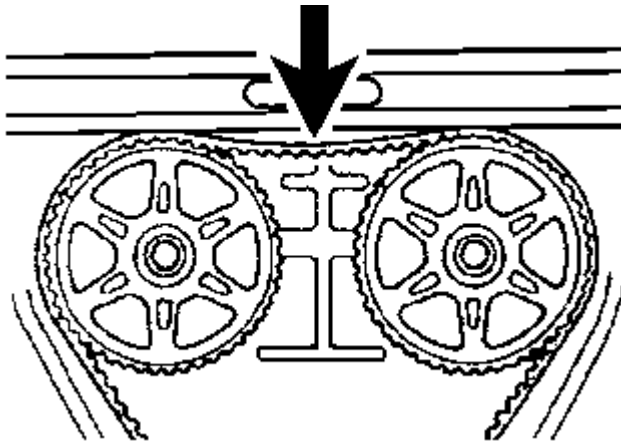

The tension is set at a deflection of:

9.0 - 11.5 mm / 98 N

Turn the engine 2 rotations by hand

Check the timing marks and tension again

Refit the spark plugs

20 Nm

Refit the crankshaft pulley

157 - 166 Nm

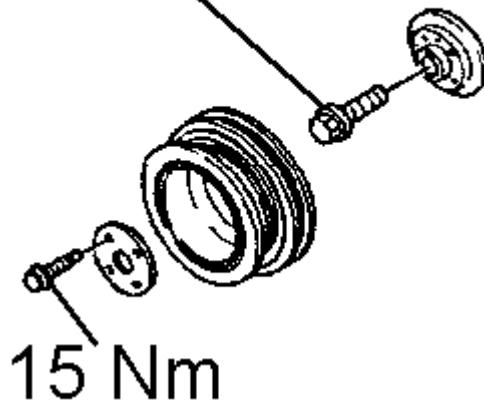

Use a special tool:

49 D011 102

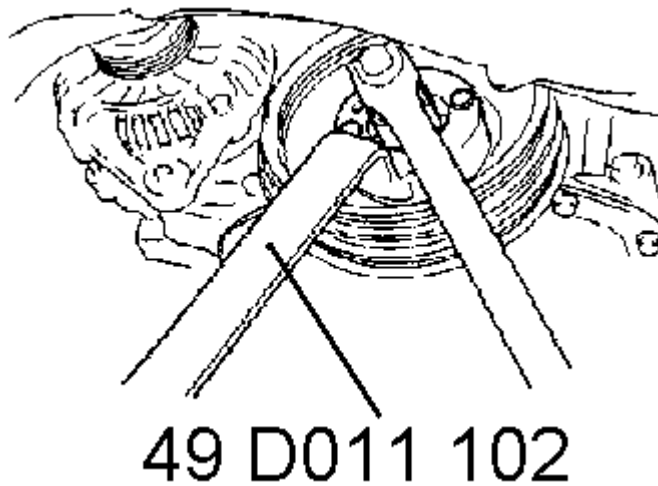

Refit the timing belt covers



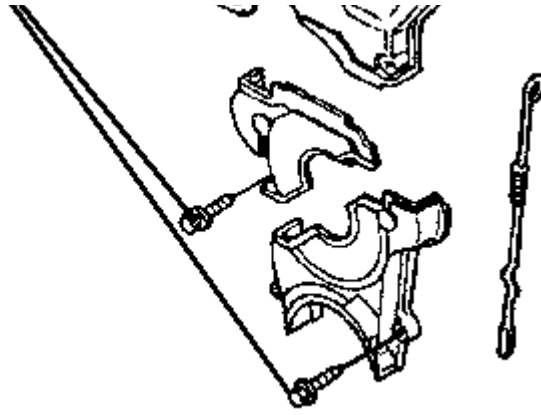

- Refit the cylinder-head cover
- Refit the dipstick tube
- Refit the spark plug leads

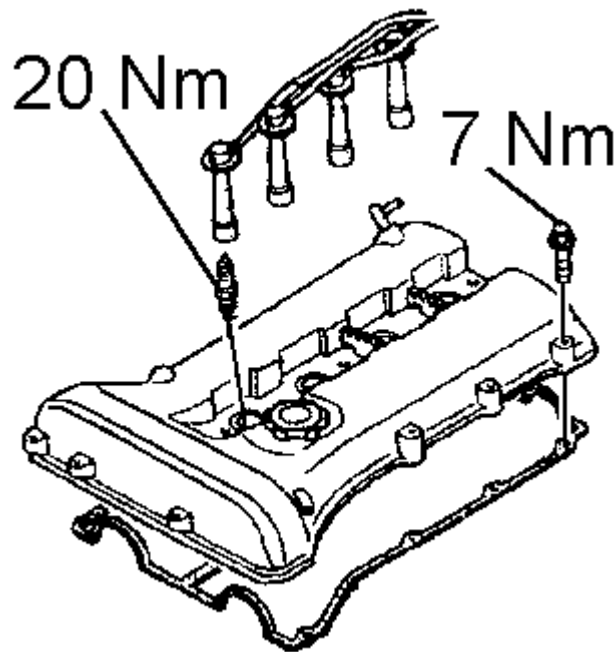

- Refit the water pump pulley
- Fit the ancillary drive belt
- Refit the engine lower covers

10 Nm

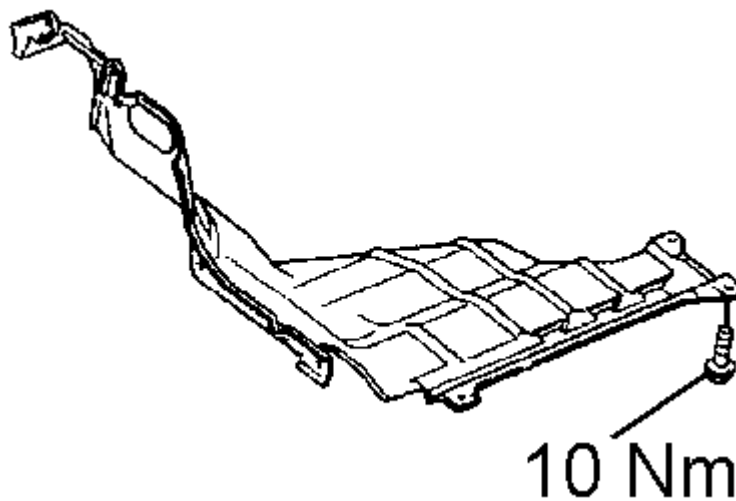

- Reconnect the battery earth cable
- Refit the right front wheel
- Check ignition timing

Torque settings

Item	Note
Crankshaft pulley:	15 Nm / 157 - 166 Nm
Water pump pulley:	10 Nm
Camshaft cover:	7 Nm
Tensioner:	38 - 51 Nm
Spark plugs:	20 Nm

Special tools

Item	Note
Crankshaft pulley:	49 D011 102