

**2007 Mazda CX-9 Grand Touring**

2007 ENGINE Cooling System (MZI-3.5) - CX-9

**2007 ENGINE**

**Cooling System (MZI-3.5) - CX-9**

**COOLING SYSTEM LOCATION INDEX [MZI-3.5]**

# 2007 Mazda CX-9 Grand Touring

## 2007 ENGINE Cooling System (MZI-3.5) - CX-9

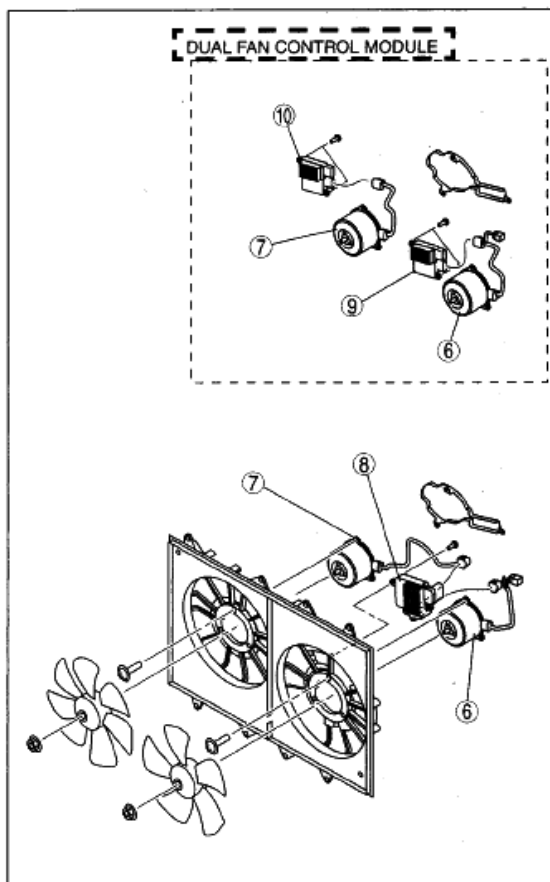
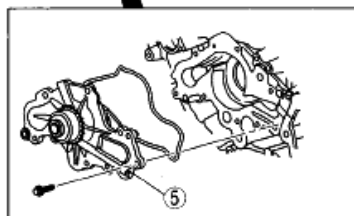
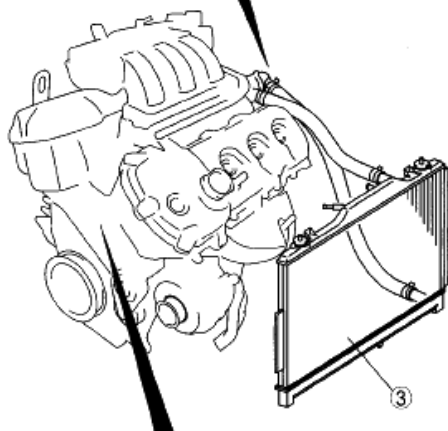
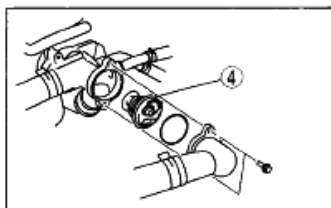

ac9uuw0002628

1	Cooling system cap (See <b>COOLING SYSTEM CAP INSPECTION [MZI-3.5].</b> )
2	Coolant reserve tank (See <b>ENGINE COOLANT LEVEL INSPECTION [MZI-3.5].</b> ) (See <b>COOLANT RESERVE TANK REMOVAL/INSTALLATION [MZI-3.5].</b> )
3	Radiator (See <b>ENGINE COOLANT PROTECTION INSPECTION [MZI-3.5].</b> ) (See <b>ENGINE COOLANT REPLACEMENT [MZI-3.5].</b> ) (See <b>ENGINE COOLANT LEAKAGE INSPECTION [MZI-3.5].</b> ) (See <b>RADIATOR REMOVAL/INSTALLATION [MZI-3.5].</b> )
4	Thermostat (See <b>THERMOSTAT REMOVAL/INSTALLATION [MZI-3.5].</b> ) (See <b>THERMOSTAT INSPECTION [MZI-3.5].</b> )
5	Water pump (See <b>WATER PUMP REMOVAL/INSTALLATION [MZI-3.5].</b> )

6	Cooling fan motor No.1 (See <b>FAN MOTOR REMOVAL/INSTALLATION [MZI-3.5].</b> ) (See <b>FAN MOTOR INSPECTION [MZI-3.5].</b> )
7	Cooling fan motor No.2 (See <b>FAN MOTOR REMOVAL/INSTALLATION [MZI-3.5].</b> ) (See <b>FAN MOTOR INSPECTION [MZI-3.5].</b> )
8	Fan control module (Single fan control module) (See <b>FAN CONTROL MODULE INSPECTION [MZI-3.5].</b> )
9	Fan control module No.1 (Dual fan control module) (See <b>FAN CONTROL MODULE INSPECTION [MZI-3.5].</b> )
10	Fan control module No.2 (Dual fan control module) (See <b>FAN CONTROL MODULE INSPECTION [MZI-3.5].</b> )

**Fig. 1: Identifying Cooling System Components**

Courtesy of MAZDA MOTORS CORP.

## **COOLING SYSTEM SERVICE WARNINGS [MZI 3.5]**

**WARNING:**

- Never remove the cooling system cap or loosen the radiator drain plug while the engine is running, or when the engine and radiator are hot. Scalding engine coolant and steam may shoot out and cause serious injury. It may also damage the engine and cooling system.
- Turn off the engine and wait until it is cool. Even then, be very careful when removing the cap. Wrap a thick cloth around it and slowly turn it counterclockwise to the first stop. Step back while the pressure escapes.
- When you are sure all the pressure is gone, press down on the cap using the cloth, turn it, and remove it.
- Depending on the vehicle, the cooling fan may operate suddenly even when the ignition switch is turned off. Therefore, keep hands and tools away from the cooling fan even if the cooling fan is not operating to prevent injury to personnel or damage to the cooling fan. Always disconnect the negative battery cable when servicing the cooling fan or parts near the cooling fan.

## **ENGINE COOLANT LEVEL INSPECTION [MZI-3.5]**

**WARNING:**

- Never remove the cooling system cap or loosen the radiator drain plug while the engine is running, or when the engine and radiator are hot. Scalding engine coolant and steam may shoot out and cause serious injury. It may also damage the engine and cooling system.
- Turn off the engine and wait until it is cool. Even then, be very careful when removing the cap. Wrap a thick cloth around it and slowly turn it counterclockwise to the first stop. Step back while the pressure escapes.
- When you are sure all the pressure is gone, press down on the cap using the cloth, turn it, and remove it.

**NOTE:**

- If the "FL22" mark is shown on or near the cooling system cap, use FL22 type engine coolant.
- FL22 type engine coolant is shipped as a diluted solution. Use the solution as is when replacing coolant.



8cxuuw00002058

**Fig. 2: Identifying "FL22" Mark On Cooling System Cap**  
Courtesy of MAZDA MOTORS CORP.

1. Verify that the engine coolant level in the coolant reserve tank is between the F and L marks.
  - If the engine coolant level is below the L mark, add engine coolant.

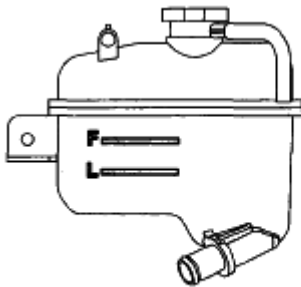

ac9uuw00002193

**Fig. 3: Identifying Engine Coolant Level In Coolant Reserve Tank**  
Courtesy of MAZDA MOTORS CORP.

## ENGINE COOLANT PROTECTION INSPECTION [MZI-3.5]

1. Measure the engine coolant temperature and specific gravity using a thermometer and a hydrometer.

### CAUTION:

- Use engine coolant at a concentration that meets the environmental conditions in which the vehicle is driven, otherwise engine damage could occur.
- The engine has aluminum parts and must be protected by an ethylene-glycol-based coolant to prevent corrosion and freezing.
- Do not use coolants containing Alcohol, Methanol, Borate or Silicate. These coolants could damage the cooling system.
- Use only soft (demineralized) water in the coolant mixture. Water that contains minerals will cut down on the coolant's effectiveness.
- Engine coolant damages paint. If engine coolant does get on a

Painted surface, rinse it off quickly.

**NOTE:**

- If the "FL22" mark is shown on or near the cooling system cap, use FL22 type engine coolant.
- FL22 type engine coolant is shipped as a diluted solution. Use the solution as is when replacing coolant.



acxuuw00002058

**Fig. 4: Identifying "FL22" Mark On Cooling System Cap**  
 Courtesy of MAZDA MOTORS CORP.

- Determine the engine coolant protection level by referring to the graph shown in the figure.
  - If the engine coolant protection level is not correct, add water or engine coolant.

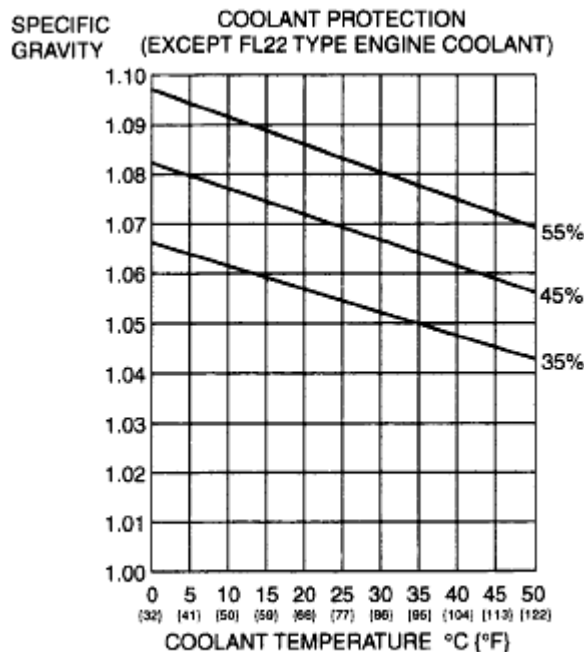

acxuuw00002059

**Fig. 5: Engine Coolant Protection Level Graph**  
 Courtesy of MAZDA MOTORS CORP.

## ENGINE COOLANT REPLACEMENT [MZI-3.5]

### WARNING:

- Never remove the cooling system cap or loosen the radiator drain plug while the engine is running, or when the engine and radiator are hot. Scalding engine coolant and steam may shoot out and cause serious injury. It may also damage the engine and cooling system.
- Turn off the engine and wait until it is cool. Even then, be very careful when removing the cap. Wrap a thick cloth around it and slowly turn it counterclockwise to the first stop. Step back while the pressure escapes.
- When you are sure all the pressure is gone, press down on the cap using the cloth, turn it, and remove it.

### CAUTION:

- Use engine coolant at a concentration that meets the environmental conditions in which the vehicle is driven, otherwise engine damage could occur.
- The engine has aluminum parts and must be protected by an ethylene-glycol-based coolant to prevent corrosion and freezing.
- Do not use coolants containing Alcohol, Methanol, Borate or Silicate. These coolants could damage the cooling system.
- Use only soft (demineralized) water in the coolant mixture. Water that contains minerals will cut down on the coolant's effectiveness.
- Engine coolant damages paint. If engine coolant does get on a painted surface, rinse it off quickly.

### NOTE:

- If the "FL22" mark is shown on or near the cooling system cap, use FL22 type engine coolant.
- FL22 type engine coolant is shipped as a diluted solution. Use the solution as is when replacing coolant.

Engine coolant capacity (approx. quantity)

Dual fan control module: 11.7 L {12.4 US qt, 10.3 Imp qt}

Single fan control module: 11.1 L {11.7 US qt, 9.77 Imp qt}



6c9uuw0002061

**Fig. 6: Identifying "FL22" Mark On Cooling System Cap**  
Courtesy of MAZDA MOTORS CORP.

1. Remove the cooling system cap.

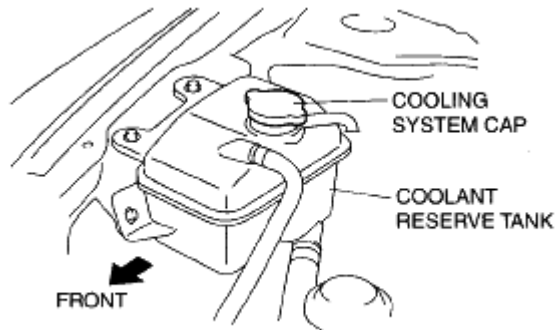

6c9uuw0002194

**Fig. 7: Identifying Cooling System Cap**  
Courtesy of MAZDA MOTORS CORP.

2. Remove the radiator drain plug and drain the engine coolant into a container.
3. Flush the cooling system with water until all traces of color are gone.
4. Let the system drain completely.
5. Tighten the radiator drain plug.

### **Tightening torque**

**1.5-2.4 N.m {15-25 kgf.cm, 13-21 in.lbf}**

6. Referring to the following chart, select the correct volume percentage of the water and engine coolant.

## 2007 Mazda CX-9 Grand Touring

2007 ENGINE Cooling System (MZI-3.5) - CX-9

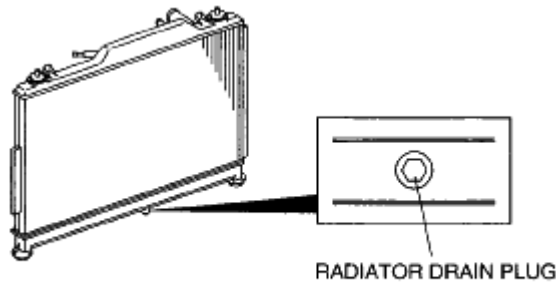

8c9uuw00002195

**Fig. 8: Identifying Radiator Drain Plug**  
Courtesy of MAZDA MOTORS CORP.

Antifreeze solution mixture percentage (Except FL22 type engine coolant)

### ENGINE COOLANT PROTECTION CHART

Engine coolant protection	Volume percentage (%)		Gravity at 20 °C {68 °F}
	Water	Coolant	
Above -16 °C {3 °F}	65	35	1.057
Above -26 °C {-15 °F}	55	45	1.072
Above -40 °C {-40 °F}	45	55	1.086

7. Refill the engine coolant into the coolant reserve tank up to the F mark on the tank.
8. Install the cooling system cap.

#### CAUTION:

- If the water temperature gauge rises too high, stop the engine and decrease the engine coolant temperature to prevent overheating. Then, verify the malfunctioning part and repair or replace it.
- If the engine coolant level in the coolant reserve tank is below the L mark during engine coolant air bleeding operation, stop the engine, and after the engine coolant temperature decreases, add engine coolant. Then, resume the engine coolant air bleeding operation.

9. Start the engine and warm up the engine by idling.
10. After the engine warms up, perform the following steps. At this time, be careful of the engine coolant temperature to prevent overheating.

#### NOTE:

- If the accelerator pedal is depressed continuously for a specified time, the engine speed may decrease to the idle speed. This does not indicate a malfunction.

1. Run the engine at approx. 4,000 rpm for 1 min.



## 2007 Mazda CX-9 Grand Touring

### 2007 ENGINE Cooling System (MZI-3.5) - CX-9

2. Run the engine at idle for **1 min.**
  3. Repeat steps (1), (2) **approx. 2 times.**
  4. Operate the heater at the maximum temperature and airflow, and verify that hot air blows from vent.
11. Stop the engine, and inspect the engine coolant level after the engine coolant temperature decreases. If it is low, repeat steps 7-10.
  12. Inspect for engine coolant leakage. (See ENGINE COOLANT LEAKAGE INSPECTION [MZI-3.5].)

## ENGINE COOLANT LEAKAGE INSPECTION [MZI-3.5]

### WARNING:

- **Never remove the cooling system cap or loosen the radiator drain plug while the engine is running, or when the engine and radiator are hot. Scalding engine coolant and steam may shoot out and cause serious injury. It may also damage the engine and cooling system.**
- **Turn off the engine and wait until it is cool. Even then, be very careful when removing the cap. Wrap a thick cloth around it and slowly turn it counterclockwise to the first stop. Step back while the pressure escapes.**
- **When you are sure all the pressure is gone, press down on the cap using the cloth, turn it, and remove it.**

1. Inspect the engine coolant level. (See ENGINE COOLANT LEVEL INSPECTION [MZI-3.5].)
2. Remove the cooling system cap.
3. Install the **SST** and a radiator cap tester to the coolant reserve tank filler port.
4. Apply pressure using the radiator cap tester.

### CAUTION:

- **Applying more than 122.6 kPa {1.25 kgf/cm<sup>2</sup>, 17.8 psi} can damage the hoses, fittings, and other components, and cause leakage.**

**Engine coolant leakage inspection pressure 122.6 kPa {1.25 kgf/cm<sup>2</sup>, 17.8 psi} [1 min]**

5. When pressurizing the cooling system, verify that the pressure is maintained.



8CXUJW00002060

**Fig. 9: Installing SST To Radiator Cap Tester**  
Courtesy of MAZDA MOTORS CORP.

- If the gauge needle drops, it may indicate water leakage. Repair or replace the applicable part.

## COOLING SYSTEM CAP INSPECTION [MZI-3.5]

### WARNING:

- **Never remove the cooling system cap or loosen the radiator drain plug while the engine is running, or when the engine and radiator are hot. Scalding engine coolant and steam may shoot out and cause serious injury. It may also damage the engine and cooling system.**
- **Turn off the engine and wait until it is cool. Even then, be very careful when removing the cap. Wrap a thick cloth around it and slowly turn it counterclockwise to the first stop. Step back while the pressure escapes.**
- **When you are sure all the pressure is gone, press down on the cap using the cloth, turn it, and remove it.**

1. Clean the cooling system cap and the sealed part.
2. Inspect the cooling system cap for cracks or everted seal.
  - If there is any malfunction, replace the cooling system cap.
3. Attach the cooling system cap to the **SST** and a radiator cap tester.
4. Hold the cooling system cap downward and apply pressure gradually. Verify that the pressure is held stable for **10 s**.
  - If the pressure is not held stable, replace the cooling system cap.

### Cooling system cap valve opening pressure

93.2-122.6 kPa {0.95-1.25 kgf/cm<sup>2</sup>, 13.5-17.8 psi}

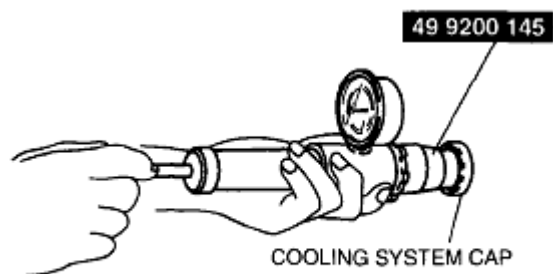

8CKJLW0002014

**Fig. 10: Attaching Cooling System Cap To SST**  
Courtesy of MAZDA MOTORS CORP.

## COOLANT RESERVE TANK REMOVAL/INSTALLATION [MZI-3.5]

### WARNING:

- Never remove the cooling system cap or loosen the radiator drain plug while the engine is running, or when the engine and radiator are hot. Scalding engine coolant and steam may shoot out and cause serious injury. It may also damage the engine and cooling system.
- Turn off the engine and wait until it is cool. Even then, be very careful when removing the cap. Wrap a thick cloth around it and slowly turn it counterclockwise to the first stop. Step back while the pressure escapes.
- When you are sure all the pressure is gone, press down on the cap using the cloth, turn it, and remove it.

1. Drain the engine coolant until the coolant reserve tank becomes empty. (See ENGINE COOLANT REPLACEMENT [MZI-3.5].)
2. Remove in the order indicated in the table.
3. Install in the reverse order of removal.
4. Refill the engine coolant. (See ENGINE COOLANT REPLACEMENT [MZI-3.5].)
5. Inspect for engine coolant leakage. (See ENGINE COOLANT LEAKAGE INSPECTION [MZI-3.5].)

## 2007 Mazda CX-9 Grand Touring

2007 ENGINE Cooling System (MZI-3.5) - CX-9

1	Hose
2	Coolant reserve tank

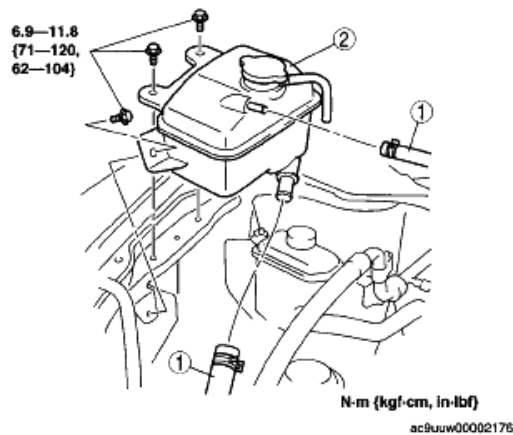

**Fig. 11: Identifying Coolant Reserve Tank And Hose With Torque Specifications**  
Courtesy of MAZDA MOTORS CORP.

### RADIATOR REMOVAL/INSTALLATION [MZI-3.5]

#### WARNING:

- Never remove the cooling system cap or loosen the radiator drain plug while the engine is running, or when the engine and radiator are hot. Scalding engine coolant and steam may shoot out and cause serious injury. It may also damage the engine and cooling system.
- Turn off the engine and wait until it is cool. Even then, be very careful when removing the cap. Wrap a thick cloth around it and slowly turn it counterclockwise to the first stop. Step back while the pressure escapes.
- When you are sure all the pressure is gone, press down on the cap using the cloth, turn it, and remove it.

1. Disconnect the negative battery cable.
2. Drain the engine coolant. (See ENGINE COOLANT REPLACEMENT [MZI-3.5].)
3. Remove the air cleaner and fresh air duct component. (see INTAKE-AIR SYSTEM REMOVAL/INSTALLATION [MZI-3.5] .)
4. Remove the cooling fan component. (See FAN MOTOR REMOVAL/INSTALLATION [MZI-3.5].)
5. Disconnect the ATF oil cooler hose from the radiator.
6. Remove in the order indicated in the table.
7. Install in the reverse order of the removal.
8. Refill the engine coolant. (See ENGINE COOLANT REPLACEMENT [MZI-3.5].)
9. Inspect for engine coolant leakage. (See ENGINE COOLANT LEAKAGE INSPECTION [MZI-3.5].)
10. Inspect the ATF level. (see AUTOMATIC TRANSAXLE FLUID (ATF) INSPECTION [AW6A-EL, AW6AX-EL] .)

## 2007 Mazda CX-9 Grand Touring

2007 ENGINE Cooling System (MZI-3.5) - CX-9

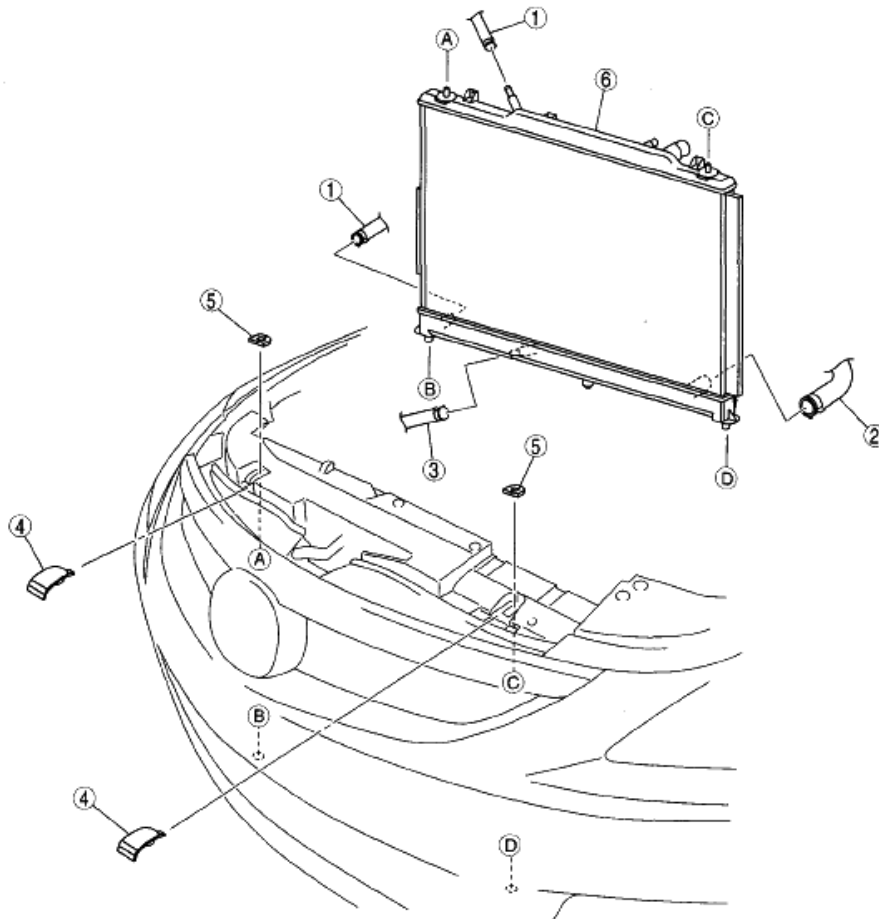

ac8uuw0002166

1	Coolant reserve tank hose
2	Lower radiator hose
3	Oil cooler water hose

4	Upper mount rubber bracket (See Upper Mount Rubber Bracket Removal Note.)
5	Upper mount rubber
6	Radiator (See Radiator Removal Note.)

**Fig. 12: Identifying Radiator Components**  
Courtesy of MAZDA MOTORS CORP.

### UPPER MOUNT RUBBER BRACKET REMOVAL NOTE

**CAUTION:**

- Do not apply force excessively and in the directions that are not specified, otherwise the upper mount rubber bracket could be damaged.

1. Insert a flathead screwdriver into the upper mount rubber bracket notch.

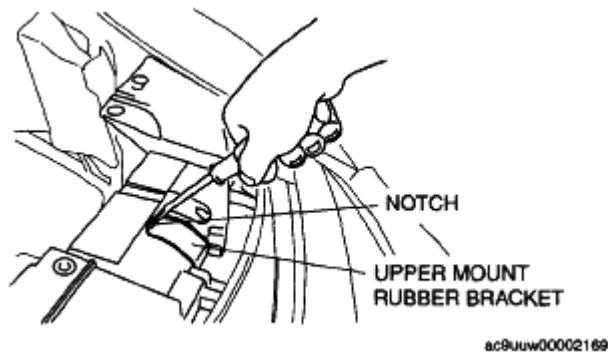

**Fig. 13: Inserting Flathead Screwdriver Into Upper Mount Rubber Bracket Notch**  
Courtesy of MAZDA MOTORS CORP.

2. Apply force in the direction shown by the arrow.

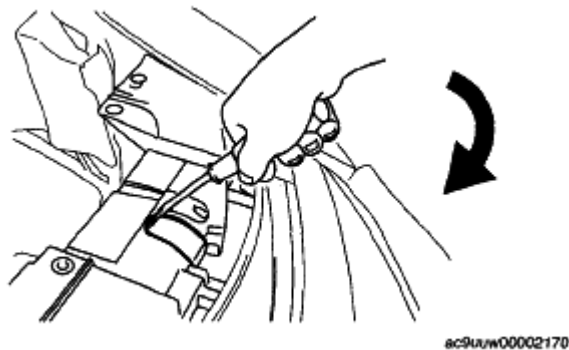

**Fig. 14: Applying Downward Force**  
Courtesy of MAZDA MOTORS CORP.

## RADIATOR REMOVAL NOTE

1. Remove the radiator from above the engine compartment.

## THERMOSTAT REMOVAL/INSTALLATION [MZI-3.5]

### WARNING:

- Never remove the cooling system cap or loosen the radiator drain plug while the engine is running, or when the engine and radiator are hot. Scalding engine coolant and steam may shoot out and cause serious injury. It may also damage the engine and cooling system.
- Turn off the engine and wait until it is cool. Even then, be very careful when removing the cap. Wrap a thick cloth around it and slowly turn it counterclockwise to the first stop. Step back while the pressure escapes.
- When you are sure all the pressure is gone, press down on the cap using the cloth, turn it, and remove it.

## 2007 Mazda CX-9 Grand Touring

### 2007 ENGINE Cooling System (MZI-3.5) - CX-9

1. Disconnect the negative battery cable.
2. Drain the engine coolant. (See **ENGINE COOLANT REPLACEMENT [MZI-3.5].**)
3. Remove the air cleaner and fresh air duct component. (see **INTAKE-AIR SYSTEM REMOVAL/INSTALLATION [MZI-3.5]** .)
4. Remove in the order indicated in the table.
5. Install in the reverse order of removal.
6. Refill the engine coolant. (See **ENGINE COOLANT REPLACEMENT [MZI-3.5].**)
7. Inspect for engine coolant leakage. (See **ENGINE COOLANT LEAKAGE INSPECTION [MZI-3.5].**)

1	Thermostat cover
2	O-ring (See O-ring Installation Note.)
3	Thermostat (See Thermostat Installation Note.)

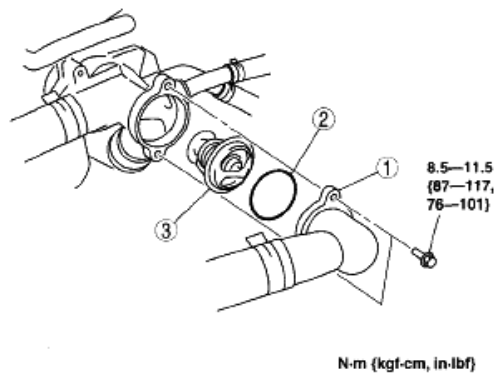

ac9uuw00002166

**Fig. 15: Identifying Thermostat Cover And Thermostat With Torque Specifications**  
Courtesy of MAZDA MOTORS CORP.

#### THERMOSTAT INSTALLATION NOTE

1. Install the thermostat into the thermostat case with the jiggle pin at the top.

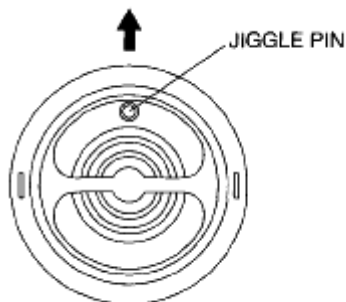

ac9uuw00002167

**Fig. 16: Identifying Jiggle Pin**  
Courtesy of MAZDA MOTORS CORP.

#### O-RING INSTALLATION NOTE

1. Clean and inspect the O-ring.

- Install a new O-ring if necessary.
- 2. Apply clean engine coolant to the O-ring.
- 3. Install the O-ring.

## THERMOSTAT INSPECTION [MZI-3.5]

1. Inspect the thermostat for the following.

**WARNING:**

- **During inspection, the thermostat and water are extremely hot and can cause severe burns. Do not touch the thermostat and water.**

- The valve should not open under normal temperature.
- Opening temperature and valve lift
  - If there is a malfunction, replace the thermostat.

### Thermostat initial-opening temperature

79.5-83.3 °C {175.2-181.9 °F}

### Thermostat full-open temperature

94.5 °C {202.1 °F}

### Thermostat full-open lift

More than 8.1 mm {0.32 in}

## WATER PUMP REMOVAL/INSTALLATION [MZI-3.5]

- WARNING:**
- Fuel vapor is hazardous. It can very easily ignite, causing serious injury and damage. Always keep sparks and flames away from fuel.
  - Fuel line spills and leakage are dangerous. Fuel can ignite and cause serious injuries or death and damage. Fuel can also irritate skin and eyes. To prevent this, always complete the "Fuel Line Safety Procedure". (see BEFORE REPAIR PROCEDURE [MZI-3.5] .)
  - Continuous exposure to USED engine oil has caused skin cancer in laboratory mice. Protect your skin by washing with soap and water immediately after working with engine oil.

- NOTE:**
- The following procedure "WATER PUMP REMOVAL/INSTALLATION" is performed after the engine and transaxle component is removed from the vehicle.



1. Drain the engine oil. (see **ENGINE OIL REPLACEMENT [MZI-3.5]** .)
2. Remove the engine and transaxle component. (see **ENGINE REMOVAL/INSTALLATION [MZI-3.5]** .)
3. Secure the engine and transaxle component using a hoist and the SST.
4. Remove the dynamic chamber and throttle body as a single unit. (see **INTAKE-AIR SYSTEM REMOVAL/INSTALLATION [MZI-3.5]** .)
5. Remove the ignition coils. (see **IGNITION COIL REMOVAL/INSTALLATION [MZI-3.5]** .)
6. Remove the dipstick.
7. Remove the power steering oil pump drive belt. (see **DRIVE BELT REMOVAL/INSTALLATION [MZI-3.5]** .)
8. Remove the power steering oil pump. (see **POWER STEERING OIL PUMP REMOVAL/INSTALLATION** .)
9. Remove the timing chain component. (see **TIMING CHAIN REMOVAL/INSTALLATION [MZI-3.5]** .)
10. Remove in the order indicated in the table.
11. Install in the reverse order of removal.
12. Start the engine and:
  1. Inspect the runout and contact on the pulley and belt.
  2. Inspect for engine oil, engine coolant, ATF, power steering fluid and fuel leakage.
  3. Verify the ignition timing, idle speed and idle mixture. (see **ENGINE TUNE-UP [MZI-3.5]** .)
  4. Engine accessories operation.
13. Perform a road test.

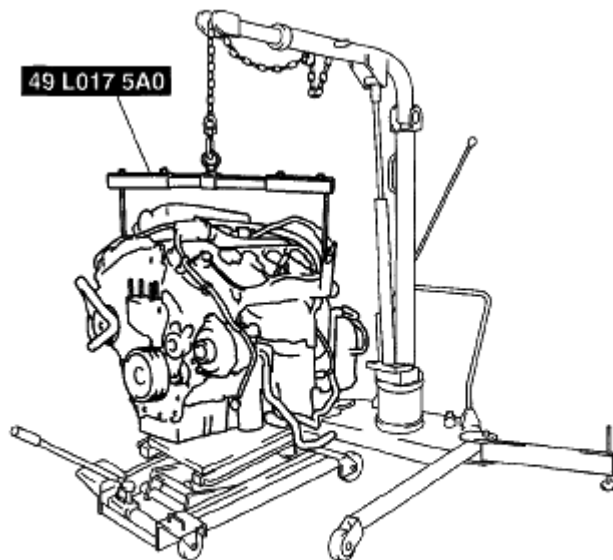

ac9uaw00001882

**Fig. 17: Securing The Engine And Transaxle Component Using Special Tool**

Courtesy of MAZDA MOTORS CORP.

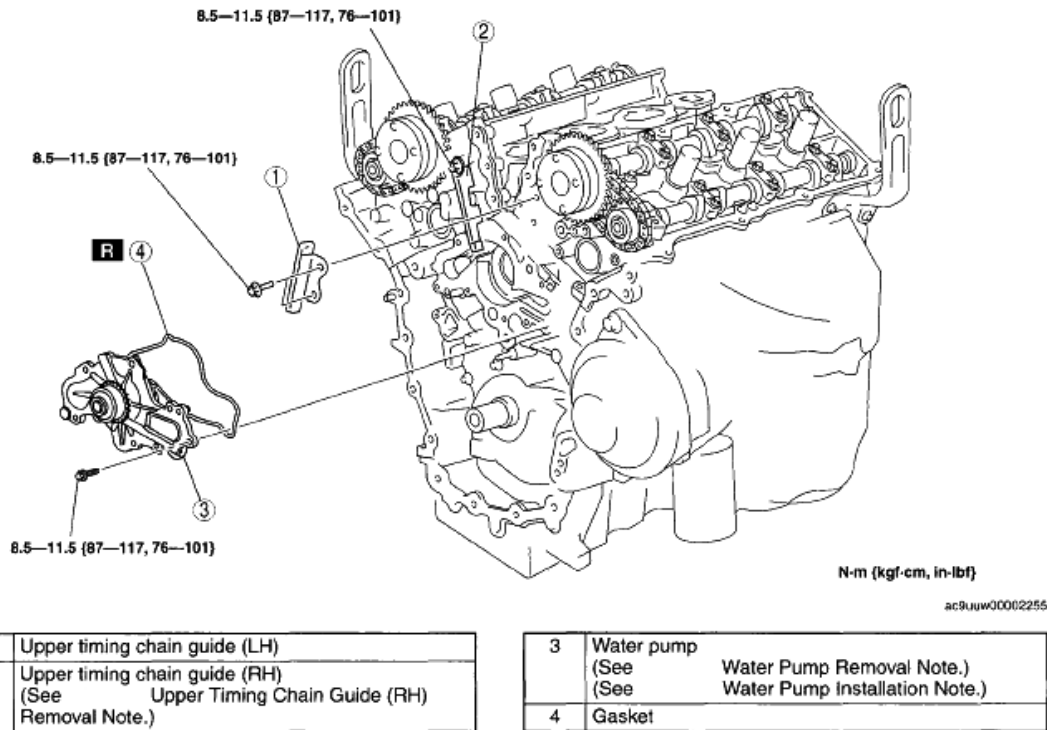

**Fig. 18: Identifying Water Pump Components With Torque Specifications**  
 Courtesy of MAZDA MOTORS CORP.

**UPPER TIMING CHAIN GUIDE (RH) REMOVAL NOTE**

1. Loosen the upper timing chain guide (RH) bolt A.
2. Remove the upper timing chain guide (RH) bolt B.

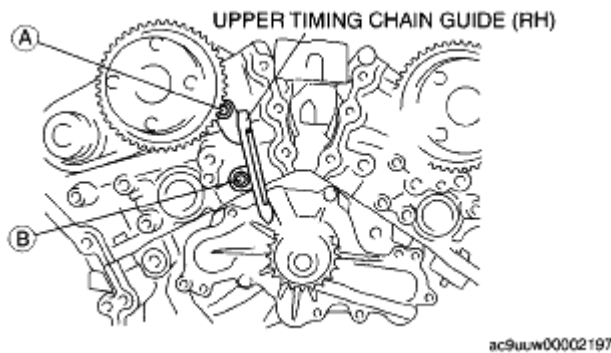

**Fig. 19: Identifying Upper Timing Chain Guide Bolts**  
 Courtesy of MAZDA MOTORS CORP.

3. Move the upper timing chain guide (RH) as shown.
4. Retighten the bolt A.

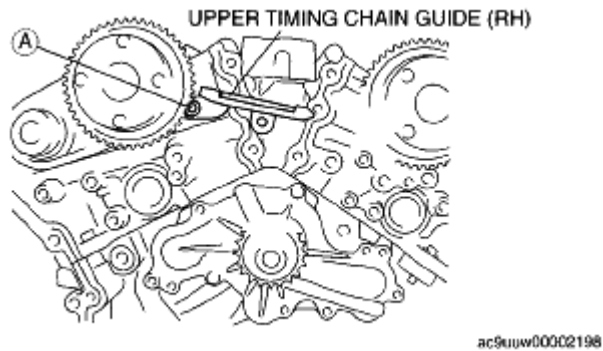

**Fig. 20: Identifying Upper Timing Chain Guide Bolt**  
Courtesy of MAZDA MOTORS CORP.

### WATER PUMP REMOVAL NOTE

**NOTE:**

- When the water pump is removed, the engine coolant may flow through the cylinder block and penetrate the oil pan. To prevent the engine coolant from accumulating in the oil pan, remove the oil pan drain plug before removing the water pump.

1. Remove the oil pan drain plug.
2. To prevent engine coolant from penetrating the oil pan, line the cylinder block with plastic sheeting as shown in the figure before removing the water pump.

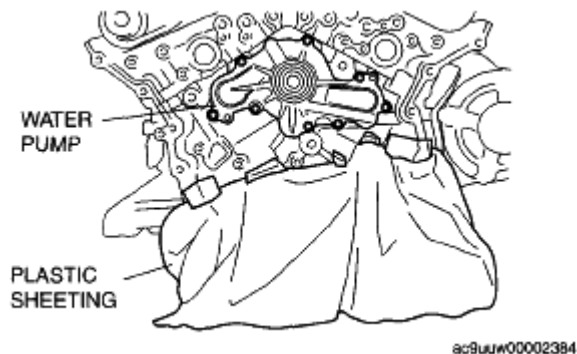

**Fig. 21: View Of Water Pump And Plastic Sheetting**  
Courtesy of MAZDA MOTORS CORP.

### WATER PUMP INSTALLATION NOTE

1. Tighten the water pump bolts in the order shown in the figure.

**Tightening torque**

**8.5-11.5 N.m {87-117 kgf.cm, 76-101 in.lbf}**

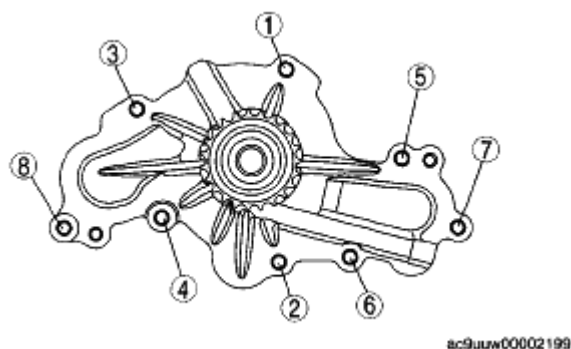

**Fig. 22: Identifying Water Pump Bolts Tightening Sequence**  
Courtesy of MAZDA MOTORS CORP.

## FAN MOTOR REMOVAL/INSTALLATION [MZI-3.5]

### WARNING:

- Never remove the cooling system cap or loosen the radiator drain plug while the engine is running, or when the engine and radiator are hot. Scalding engine coolant and steam may shoot out and cause serious injury. It may also damage the engine and cooling system.
- Turn off the engine and wait until it is cool. Even then, be very careful when removing the cap. Wrap a thick cloth around it and slowly turn it counterclockwise to the first stop. Step back while the pressure escapes.
- When you are sure all the pressure is gone, press down on the cap using the cloth, turn it, and remove it.

1. Disconnect the negative battery cable.
2. Drain the engine coolant. (See ENGINE COOLANT REPLACEMENT [MZI-3.5].)
3. Remove the air cleaner and fresh air duct component. (see INTAKE-AIR SYSTEM REMOVAL/INSTALLATION [MZI-3.5] .)
4. Remove the engine cover.
5. Remove the dipstick.
6. Remove in the order indicated in the table.
7. Install in the reverse order of removal.
8. Refill the engine coolant. (See ENGINE COOLANT REPLACEMENT [MZI-3.5].)
9. Inspect for engine coolant leakage. (See ENGINE COOLANT LEAKAGE INSPECTION [MZI-3.5].)

# 2007 Mazda CX-9 Grand Touring

## 2007 ENGINE Cooling System (MZI-3.5) - CX-9

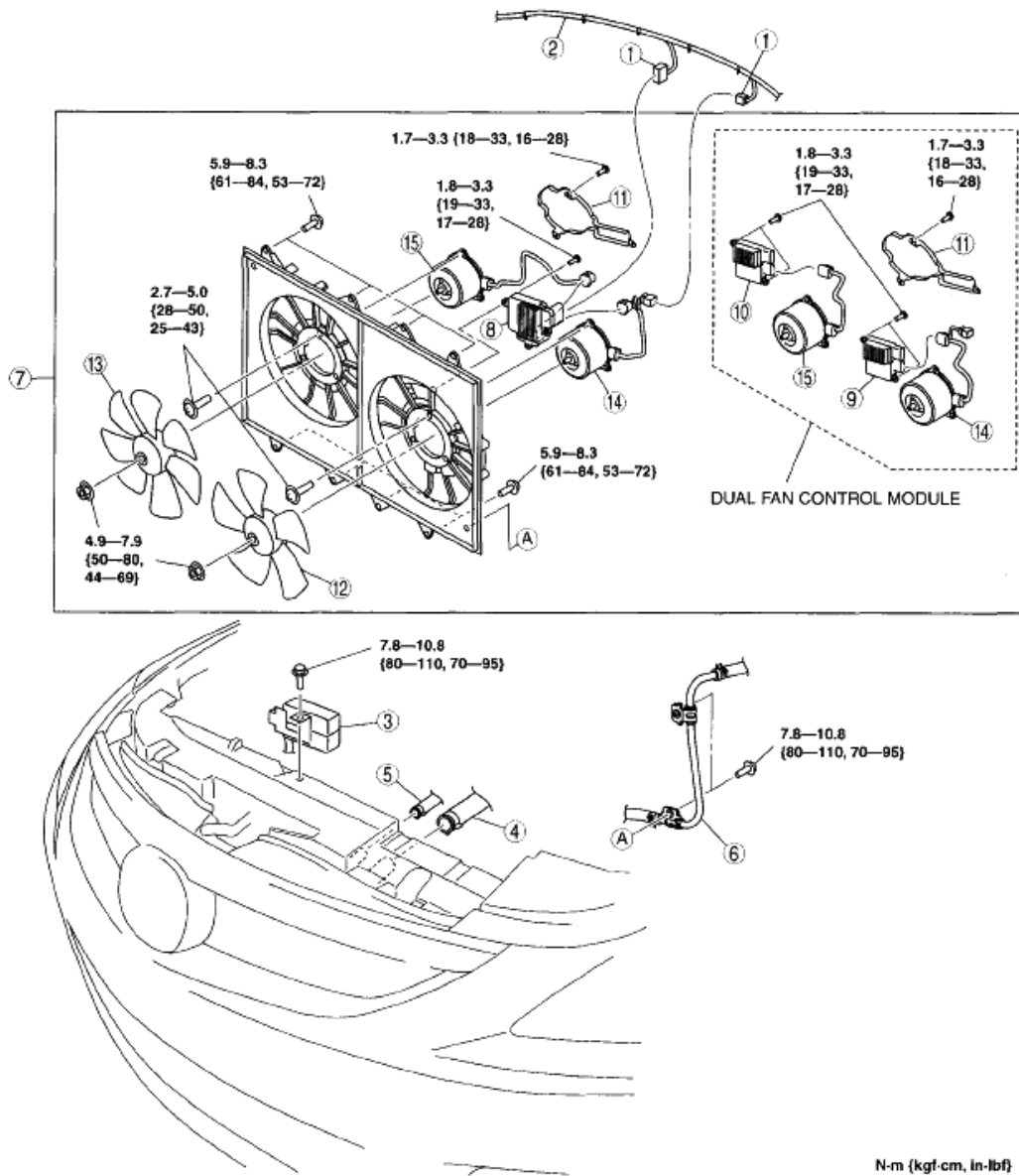

1	Connector
2	Wiring harness
3	Relay box
4	Upper radiator hose
5	Oil cooler water hose
6	ATF oil cooler pipe (See ATF Oil Cooler Pipe Removal Note.)
7	Cooling fan component (See Cooling Fan Component Removal Note.)

8	Fan control module (Single fan control module)
9	Fan control module No.1 (Dual fan control module)
10	Fan control module No.2 (Dual fan control module)
11	Heat insulator
12	Cooling fan No.1
13	Cooling fan No.2
14	Cooling fan motor No.1
15	Cooling fan motor No.2

**Fig. 23: Identifying Fan Motor Components With Torque Specifications**  
 Courtesy of MAZDA MOTORS CORP.

### ATF OIL COOLER PIPE REMOVAL NOTE

1. Remove the ATF oil cooler pipe with the hoses still connected. Position the ATF oil cooler pipe so that it is out of the way.

### COOLING FAN COMPONENT REMOVAL NOTE

1. Remove the cooling fan component from above the engine compartment.

## FAN MOTOR INSPECTION [MZI-3.5]

### PART INSPECTION

1. Verify that the battery is fully charged. (see **BATTERY INSPECTION [MZI-3.5]** .)
2. Disconnect the cooling fan motor connector (fan control module side, 2 terminals).
3. Install a tester and battery to the cooling fan motor connector as shown in the figure.
4. Verify that each fan motors operate smoothly at the standard current.
  - If there is any malfunction, replace the applicable part.

#### Cooling fan motor standard current [Single Fan Control Module]

No.1, No.2: 11.2-15.2 A

#### Cooling fan motor standard current [Dual Fan Control Module]

No.1, No.2:17-23 A

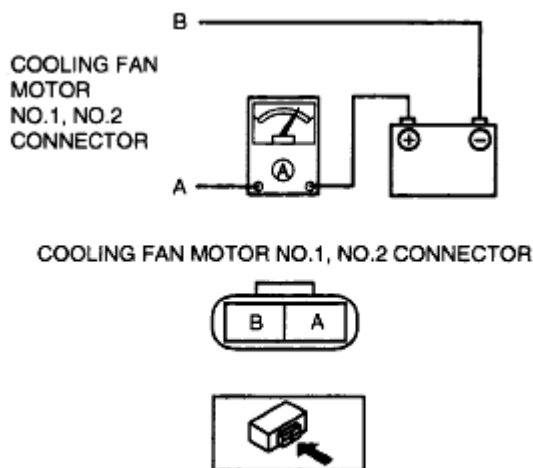

acxjuw00002065

**Fig. 24: Installing Tester And Battery To Cooling Fan Motor Connector (2 Terminals)**  
Courtesy of MAZDA MOTORS CORP.

## FAN CONTROL MODULE INSPECTION [MZI-3.5]

1. Connect the M-MDS to the DLC-2.
2. Start and warm up the engine.
3. Monitor the engine coolant temperature with the M-MDS.

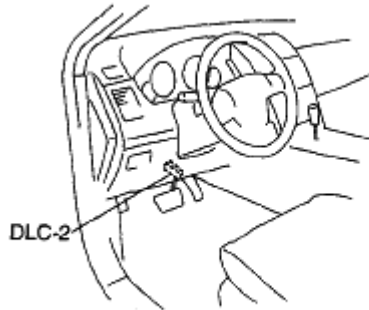

ac9uuw00002177

**Fig. 25: Identifying DLC-2 Connector**  
 Courtesy of MAZDA MOTORS CORP.

4. Measure the voltage at terminal A of the fan control module connector (2 terminal) as shown in the table.
  - If not within the specification, inspect the input signals from the following parts.
    - Cylinder Head Temperature (CHT) sensor
    - Refrigerant pressure switch (middle)

FAN CONTROL MODULE CONNECTOR

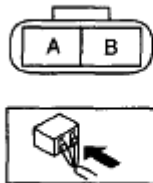

ac9uuw00002178

**Fig. 26: Identifying Fan Control Module Connector Terminals**  
 Courtesy of MAZDA MOTORS CORP.

Single fan control module

SINGLE FAN CONTROL MODULE SPECIFICATION

Condition	Inspection		Result
	A/C	Engine coolant temp.	
IG SW ON or idling	OFF	Less than 96 °C {205 °F}	0 V (Fan stops.)
Idling	OFF	96-106 °C {205-223 °F}	4.11-10.29 V
Idling	ON <sup>(0)</sup>	96-106 °C {205-223 °F}	Approx. 6.4 V
Idling	ON <sup>(0)</sup>	96-106 °C {205-223 °F}	Approx. 7.7 V

## 2007 Mazda CX-9 Grand Touring

2007 ENGINE Cooling System (MZI-3.5) - CX-9

Idling	OFF	More than 106 °C {223 °F}	B+
--------	-----	---------------------------	----

### Dual fan control module

#### DUAL FAN CONTROL MODULE SPECIFICATION

Inspection			Result
Condition	A/C	Engine coolant temp.	
IG SW ON or idling	OFF	Less than 96 °C {205 °F}	0 V (Fan stops.)
Idling	OFF	96-106 °C {205-223 °F}	4.11-10.29 V
Idling	ON <sup>(2)</sup>	96-106 °C {205-223 °F}	Approx. 6.6 V
Idling	ON <sup>(2)</sup>	96-106 °C {205-223 °F}	Approx. 7.5 V
Idling	OFF	More than 106 °C {223 °F}	B+
(1) Refrigerant pressure switch (middle) is off.			
(2) Refrigerant pressure switch (middle) is on.			

5. If all the above parts are normal, replace the fan control module.