

ENGINE

CONTENTS

4G9 ENGINE	11A
F8QT ENGINE	11B

4G9 ENGINE

CONTENTS

GENERAL	2	SPECIAL TOOL	2
Outline of Changes	2	ON-VEHICLE SERVICE	3
GENERAL INFORMATION	2	Ignition Timing Check and Adjustment	3
SERVICE SPECIFICATIONS	2		

GENERAL**OUTLINE OF CHANGES**

- The 6B model specification has been added as one of the 4G92 engines.
 - The ignition timing for the SOHC engine has been changed.
 - The ignition timing adjustment connector has been abolished.
- The following service procedures have been added to correspond to the changes above.

GENERAL INFORMATION

Items			4G92 (6B models)
Valve timing	Intake	Opening	14°
		Closing	58°
	Exhaust	Opening	52°
		Closing	16°

SERVICE SPECIFICATIONS

Items		Standard value
Basic ignition timing	SOHC	5° BTDC ± 3°
Idle speed r/min	4G92-SOHC (6B models)	800 ± 100

SPECIAL TOOL

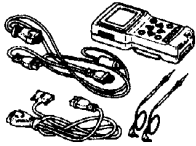
Tool	Number	Name	Use
	MB991502	MUT-II sub assembly	<ul style="list-style-type: none"> • Basic ignition timing check • Idle speed check

ON-VEHICLE SERVICE

IGNITION TIMING CHECK AND ADJUSTMENT

1. Set the vehicle to the pre-inspection conditions.
2. Connect the MUT-II to the diagnosis connector.
3. Connect a timing light.
4. Start the engine and let it at idle.
5. Read out engine speed by using the MUT-II, and check that the idle speed is at approx. 750 r/min <4G92-SOHC> or approx. 800 r/min <4G92-SOHC (6B models), 4G93-SOHC, 4G93-DOHC>.
6. Select No. 17 (actuator test function) from the MUT-II items, and set ignition timing to the basic ignition timing.
7. Check the basic ignition timing.

Standard value: 5° BTDC ± 3°

8. If it is not within the standard value, check the MPI system by referring to GROUP 13A - Troubleshooting.
9. Press the clear key on the MUT-II to release the basic ignition timing set mode by means of the actuator test function.

Caution

If it can not be released, the basic ignition timing set mode will continue for 27 minutes, causing the engine to be damaged.

10. Check that the ignition timing is at the standard value.

Standard value:

4G92-SOHC, 4G93-DOHC approx. 8° BTDC

4G93-SOHC approx. 10° BTDC

NOTE

The ignition timing may fluctuate within approx. ±7°. However, this is normal.

F8QT ENGINE

CONTENTS

GENERAL	2	Compression Pressure Check	13
Outline of Changes	2	Timing Belt Tension Adjustment	15
GENERAL INFORMATION	3	CRANKSHAFT PULLEY	16
SERVICE SPECIFICATIONS	3	CAMSHAFT AND CAMSHAFT OIL SEAL ...	18
SEALANT	4	OIL PAN	20
SPECIAL TOOLS	4	CRANKSHAFT OIL SEAL	22
ON-VEHICLE SERVICE	7	INTERMEDIATE SHAFT OIL SEAL	24
Drive Belt Tension Check and Adjustment	7	CYLINDER HEAD GASKET	25
Valve Clearance Check and Adjustment	8	TIMING BELT	30
Injection Timing Check and Adjustment	10	ENGINE ASSEMBLY	32
Idle Speed Check and Adjustment	12		
Fast Idle Speed Check and Adjustment	13		

GENERAL**OUTLINE OF CHANGES**

- The following service procedures have been added to correspond to the addition of the diesel-powered vehicle.

Applicable models: 1900D

1. On-vehicle Service
2. Removal and installation of the crankshaft pulley
3. Removal and installation of the camshaft and camshaft oil seal
4. Removal and installation of the oil pan
5. Removal and installation of the crankshaft oil seal
6. Removal and installation of the cylinder head gasket
7. Removal and installation of the timing belt
8. Removal and installation of the engine assembly

GENERAL INFORMATION

Items		Specification	
Total displacement cm ³		1,870	
Bore × Stroke mm		80 × 93	
Compression ratio		21	
Combustion chamber		Swirl chamber	
Camshaft arrangement		SOHC	
Number of valve	Intake	4	
	Exhaust	4	
Valve timing	Intake	Opening	0° BTDC
		Closing	18° ABDC
	Exhaust	Opening	41° BBDC
		Closing	0° ATDC
Fuel system		Distribution type injection pump	



SERVICE SPECIFICATIONS

Items		Standard value	Limit
Alternator drive belt deflection amount mm	When checked	3.5	-
	When a used belt is installed	3.0	-
	When a new belt is installed	2.0 - 3.0	-
Valve clearance (at cold) mm	When checking	Intake valve	0.15 - 0.25
		Exhaust valve	0.35 - 0.45
	When adjusting	Intake valve	0.20
		Exhaust valve	0.40
Idle speed r/min		825 ± 25	-
Idle up speed r/min		900 ± 50	-
Compression pressure (250 - 400 r/min) kPa		-	min. 2,000
Compression pressure difference of all cylinder kPa		-	max. 400

SEALANT

Item	Specified sealant	Remark
Oil pan	MITSUBISHI GENUINE PART MD970389 or equivalent	Semi-drying sealant
Cam cap (No.1 and No.5)		
Fly wheel bolt, Crankshaft pulley bolt	3M stud locking 4170 or equivalent	Anaerobic sealant

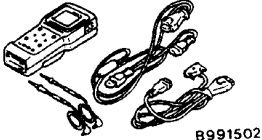
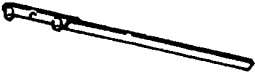
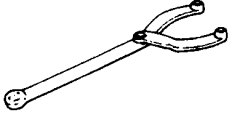
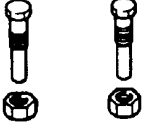

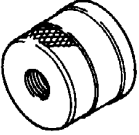
SPECIAL TOOLS

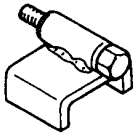
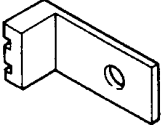
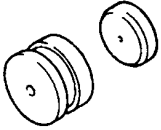
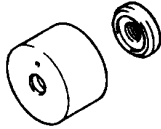
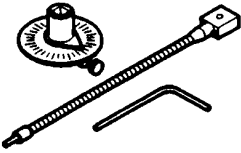
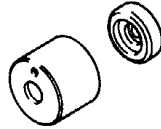
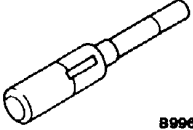
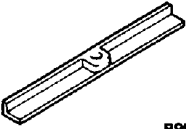
Tool	Number	Name	Use
 8991502	MB991502	MUT-II sub assembly	Checking of idle speed
	MD998747	Crankshaft pulley holder	Holding the crankshaft pulley
	MB990767	End yoke holder	Holding the camshaft sprocket
	MD998715 or MD998754	Crankshaft pulley holder pin	
	MD998727	Oil pan remover	Removal of oil pan
	MB996042	Oil seal installer	Installation of camshaft oil seal

Tool	Number	Name	Use
	MB996034	Sprocket stopper	Removal of intermediate shaft sprocket
	MB996015	Flywheel stopper	Locking the flywheel
	MB996038	Oil seal installer	Installation of the crankshaft rear oil seal
	MB996040	Oil seal installer	Installation of the crankshaft front oil seal
	MB991614	Angle gauge	Tightening of the cylinder head bolts
	MB996039	Oil seal installer	Installation of the intermediate shaft oil seal
 <p data-bbox="347 1507 416 1525">B996032</p>	MB996032	Tension gauge	<ul style="list-style-type: none"> ● Adjustment of drive belt tension ● Adjustment of timing belt tension
 <p data-bbox="352 1686 421 1704">B996033</p>	MB996033	Tension gauge	Adjustment of timing belt tension

11B-6

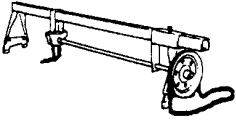
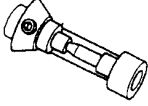
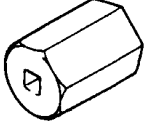
F8QT ENGINE – Special Tools

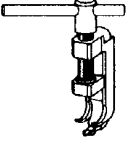
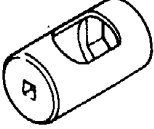
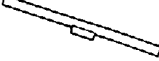
Tool	Number	Name	Use
 <p style="text-align: center;">Z203827</p>	<p>GENERAL SERVICE TOOL MZ203827</p>	<p>Engine lifter</p>	<p>Supporting the engine assembly during removal and installation of the transmission</p>
 <p style="text-align: center;">MB996030</p>	<p>MB996030</p>	<p>Measuring device adapter</p>	<p>Adjustment of injection timing</p>
	<p>MB996036</p>	<p>Hexagon socket</p>	
 <p style="text-align: center;">MB996037</p>	<p>MB996037</p>	<p>Sprocket adapter</p>	
	<p>MB996043</p>	<p>Sprocket stopper</p>	
 <p style="text-align: center;">MB996035</p>	<p>MB996035</p>	<p>Valve lifter</p>	<p>Adjustment of valve clearance</p>
	<p>MB996041</p>	<p>Special socket</p>	<p>Removal of fuel injector</p>
 <p style="text-align: center;">MB996045</p>	<p>MB996045</p>	<p>Tension gauge</p>	<p>Checking of drive belt tension</p>

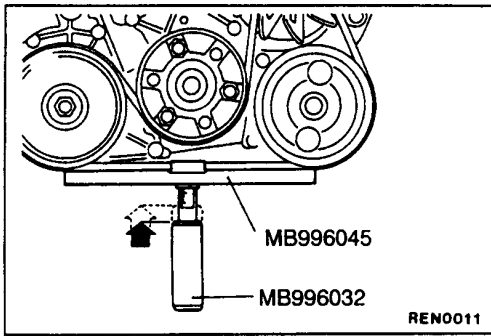

ON-VEHICLE SERVICE

DRIVE BELT TENSION CHECK AND ADJUSTMENT <ONLY VEHICLES WITH A/C>

1. Fit special tools on the belt.
2. Slide the O-ring of the measuring tool under the graduated scale.
3. Locate the measuring tool and push it in as far as is shown in the drawing.
4. This position can also be felt (with the thumb) because the measuring pin is then flush with the top of the measuring tool.
5. Carefully remove the measuring tool and read off the belt tension (in mm).

Standard value:

Item	When checked	When a used belt is installed	When a new belt is installed
Tension mm	3.5	3.0	2.0 - 3.0

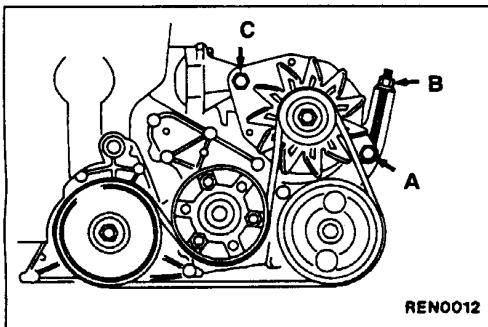

6. If the tension is not at the standard value, loosen the alternator mounting bolt and nut, and turn the adjusting nut to adjust the tension.
7. Tighten the alternator mounting bolt and nut.

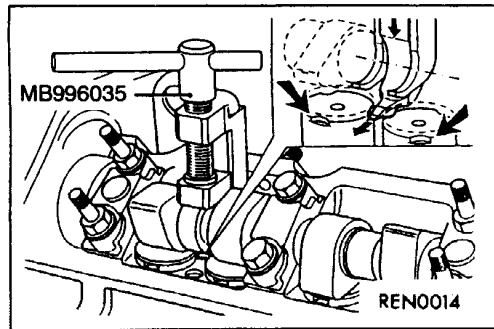
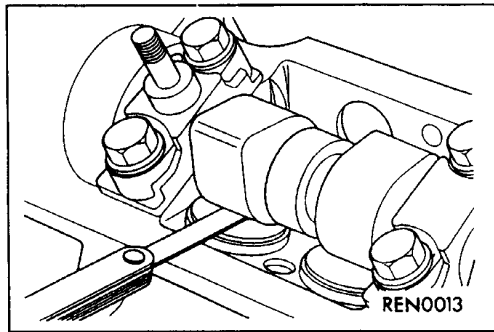
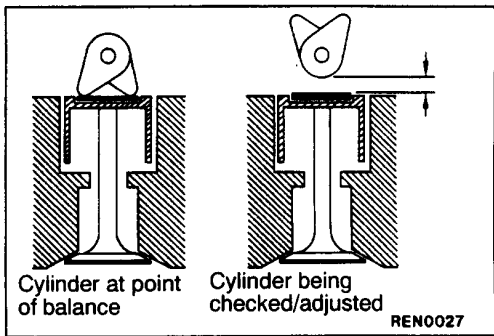

VALVE CLEARANCE CHECK AND ADJUSTMENT

1. The valve clearances have to be checked/adjusted in the following sequence:

Cylinder at point of balance	Cylinder being checked/adjusted
1	4
2	3
3	2
4	1

2. Measure the valve clearance.

Standard value (cold engine):

Intake valve: 0.15 - 0.25 mm

Exhaust valve: 0.35 - 0.45 mm

3. If the valve clearance is outside the standard value, adjust by replacing the tappet pads using the following procedure.

4. Unscrew the base of special tool a distance of 6 mm.
5. Turn the slots in the tappet to the correct position; see the illustration.
6. Position special tool with the base in the slots of the tappets and then push the tool forwards as far as possible.
7. Depress the tappets.

Caution

When changing tappet pads the piston must not be at TDC. The crankshaft must be turned on to bring it just past TDC, otherwise the valves may strike the piston when the tappets are depressed.

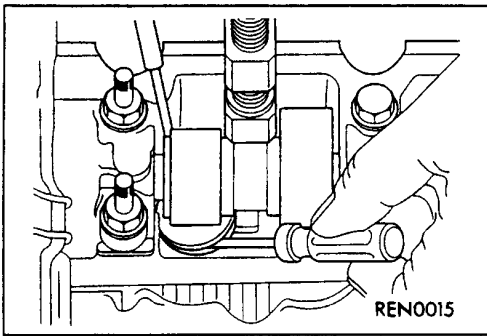

8. Use a small screwdriver to remove the tappet pad.
9. Select tappet pads which will bring the valve clearance to the standard value.

Standard value (cold engine):

Intake valve: 0.20 mm

Exhaust valve: 0.40 mm

Example

If the measured valve clearance is 0.25 mm and the required valve clearance is 0.40 mm, then the old tappet pad must be replaced by a new pad which is 0.15 mm thinner.

NOTE

1. Measure the thickness of the tappet pad with a micrometer.
2. Always use new tappet pads.
3. Tappet pads are available in thicknesses from 3.25 mm to 4.25 mm, increasing by increments of 0.05 mm; and in thicknesses from 4.30 to 4.50 mm, increasing by increments of 0.10 mm.

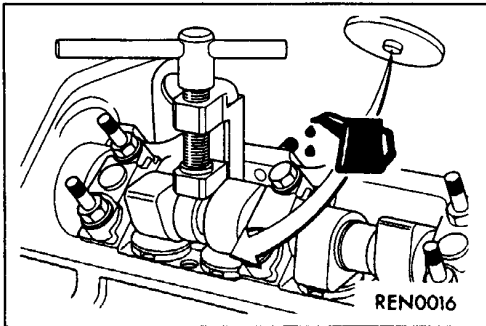

10. The tappet pad must be lubricated with oil and installed with the projection facing towards the tappet.

INJECTION TIMING CHECK AND ADJUSTMENT

1. Turn the crankshaft clockwise to set the No.1 cylinder to top dead compression centre.
2. Turn the crankshaft 1 3/4 revolutions in its normal direction of rotation.
3. Remove the plug (A).

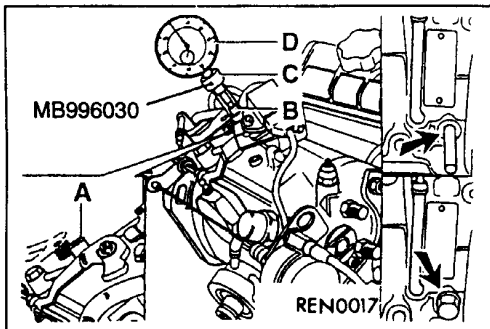

4. Fit special tool:
 - Locate the guide bush in the pump.
 - Slide the measuring pin (B), which is part of the special tool, into the guideway of the pump.
 - Locate and secure the holder (C).
 - Position the clock gauge (D) and make sure that the plunger is pressed in at least 0.2 mm. Secure the clock gauge and set it at zero.

NOTE

The measuring pin and guide bush can only be supplied and used as a set.

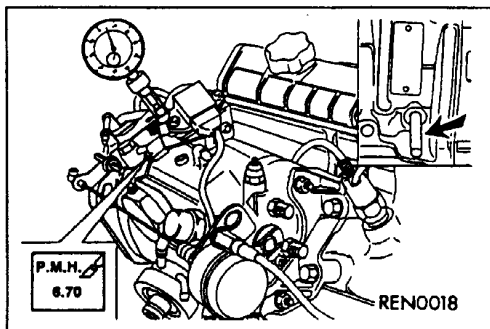

5. Turn the crankshaft in its normal direction of rotation until the clock gauge indicates approximately 5.00 mm.
6. Apply pressure on the locking pin and turn the crankshaft in its normal direction of rotation until the locking pin engages the recess in the crankshaft web.
7. Read off the value on the clock gauge.
8. The reference value for checking purposes is approximately 0.02 mm; this is shown on the pump control arm.
9. If the reference value is not obtained, the pump will have to be adjusted.

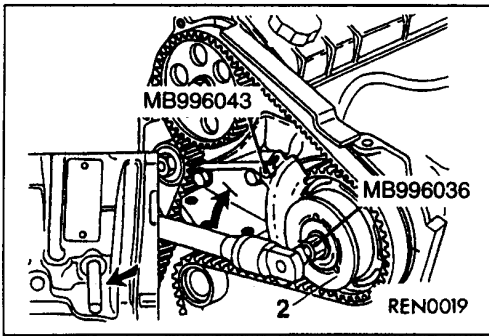

10. Locate special tool (sprocket stopper) between the pump bracket and the sprocket. Secure the tool with the bolt supplied with the set.
11. Insert special tool (hexagon socket) in the screwed sleeve and nut assembly. Back off (turning clockwise) the screwed sleeve and nut assembly one eighten of a turn. It should now be possible to move the flange (2).
12. Remove special tool (sprocket stopper), the locking pin and the clock gauge.

Caution

The plunger is not spring-mounted! When turning over the engine it is possible to break the clock gauge.

13. Turn the crankshaft 1 3/4 revolutions further, locate the clock gauge and make sure that the plunger is pressed in at least 0.2 mm. Check and adjust the injection timing.

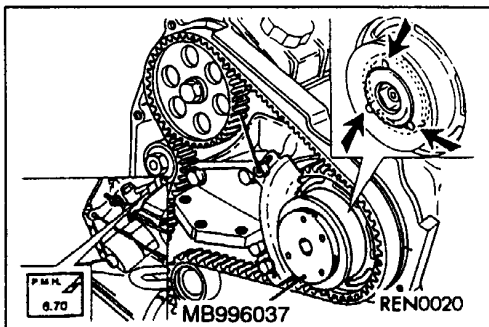

14. Fit special tool in the three holes of the flange.
15. Turn the tool with the flange until the jaws of the tool engage the three internal recesses of the sprocket.
16. Turn the tool with the flange clockwise until the backlash in the pump is eliminated and then turn it to 0.5 mm below the adjustment reference value.
17. Now turn the tool with the flange counter-clockwise until the adjustment reference value is obtained as shown on the pump ± 0.02 mm.
18. Locate special tool (sprocket stopper) and secure it with the bolt supplied with the set.
19. Turn the bracket with the bolt (F) so that the bracket is free from play.

Caution

The pump sprocket must not be displaced (the pointer of the micrometer must not move).

20. Insert special tool (hexagon socket) in the screwed sleeve and nut assembly and tighten the assembly steadily (turning counter-clockwise) to the specified torque.
21. Remove special tool (sprocket stopper), the locking pin and the clock gauge.

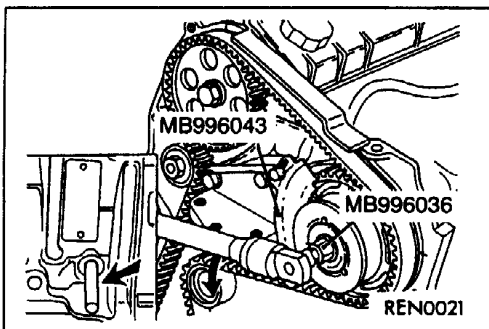

22. Turn the crankshaft 1 3/4 revolutions further, locate the clock gauge and make sure that the plunger is pressed in at least 0.2 mm.
23. Check the injection timing.
24. Remove special tool together with the clock gauge and measuring pin. Fit the plug with a new O-ring.
25. Tighten the plug to the specified torque.

Specified torque: 10 Nm

26. Remove the locking pin and fit the plug with a new sealing washer.
27. Tighten the plug to the specified torque.

Specified torque: 20 Nm

IDLE SPEED CHECK AND ADJUSTMENT

1. Before inspection, set the vehicle to the pre-inspection condition.
2. Connect the MUT-II to the diagnosis connector.
3. Check the idle speed.

Standard value: 825 ± 25 r/min

4. If the idle speed is outside the standard value range, adjust by the following procedure.
5. Loosen the lock nut, and then turn the idle adjustment screw to adjust the idle speed to the standard value.
6. Tighten the lock nut to secure the idle adjustment screw.
7. Insert a feeler gauge with a thickness of 4 mm between the throttle elver and the stopper screw.
8. Check that the idle speed is at 1,250 ± 100 r/min. If the idle speed is outside this range, adjust by turning the stopper screw.
9. Tighten the lock nut to secure the stopper screw.
10. Remove the feeler gauge.
11. Check that the idle speed is within the standard value range. If the idle speed is outside the standard value range, repeat the adjustment procedure from step 5.
12. Disconnect the MUT-II.

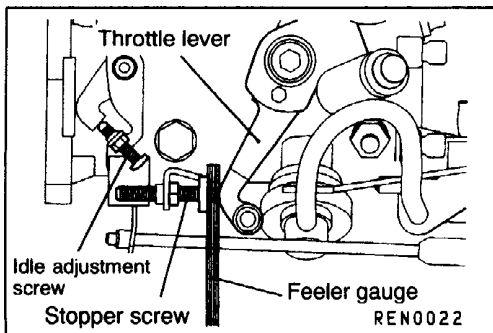

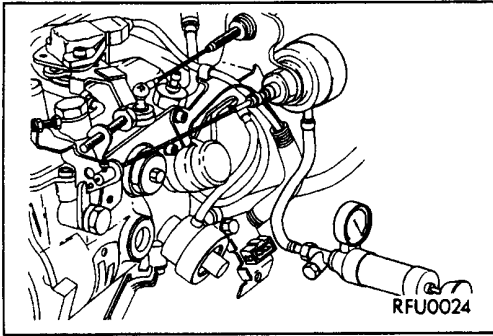

FAST IDLE SPEED CHECK AND ADJUSTMENT

1. Disconnect the vacuum hose from idle up actuator.
2. Connect a hand vacuum pump to the idle up actuator nipple.
3. Connect the MUT-II to the diagnosis connector.
4. Start the engine and run at idle.
5. Check the idle speed and adjust necessary.
6. Stop the engine.

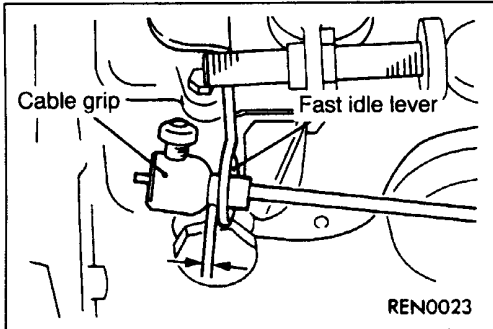

7. Adjust the clearance between the cable grip and the first idle lever so that it is at the standard value.

Standard value: 2 ± 1 mm

8. Start the engine and check the engine speed when negative pressure (27 kPa or more) is applied to the idle up actuator using the hand vacuum pump.

Standard value: 900 ± 50 r/min

NOTE

The fast idle speed valve cannot be directly adjusted; it is adjusted using an injection test bench.

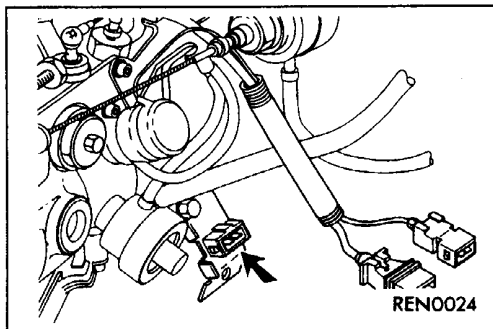

COMPRESSION PRESSURE CHECK

1. Before inspection, check that the engine oil, starter and battery are normal. In addition, set the vehicle to the pre-inspection condition.
2. Disconnect the fuel cut solenoid valve (immobilizer) connector.
3. Remove the fuel injection pipes. Plug all the connections.
4. Disconnect the needle lift sensor connector.
5. Remove the fuel return hoses and plug the connections

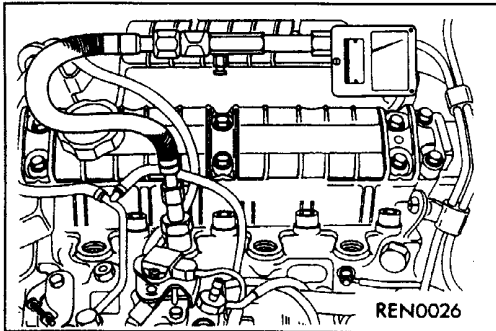
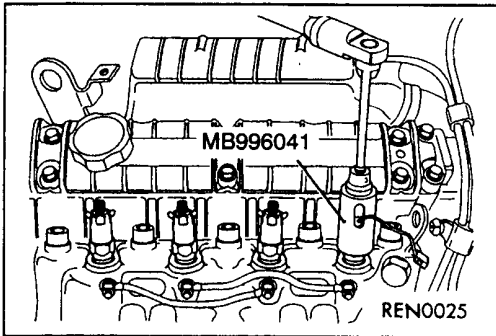

6. Use the special tool to remove the injection nozzle.
7. Remove the heat shield.
8. Cover the injection nozzle holes with a rag etc., and after the engine has been cranked, check that no foreign material is adhering to the rag.

Caution

1. **When you crank the engine, keep away from the injection nozzle mounting holes.**
 2. **If a compression measurement is performed with water, oil, fuel, etc. in the cylinder due to the cracks in the cylinders, these substances heated to a very high temperature will blow off the injection nozzle mounting holes and could be dangerous.**
9. Install the heat shield and sealing ring to the cylinder head.
 10. Connect the compression gauge to the special tool.
 11. Crank the engine and measure the compression pressure.

Limit: 2,000 kPa

12. Measure the compression for all the cylinders, and check that the pressure differences of the cylinders are below the limit.

Limit: Max. 400 kPa

13. If there is a cylinder with compression or a compression difference that is outside the limit, pour a small amount of engine oil through the injection nozzle hole, and repeat the operations in steps 12 and 13.
 - (1) If the compression increases after oil is added, the cause of the malfunction is a worn or damaged piston ring and/or cylinder inner surface.
 - (2) If the compression does not rise after oil is added, the cause is a burnt or defective valve or pressure is leaking from the gasket.
14. Remove the compression gauge.

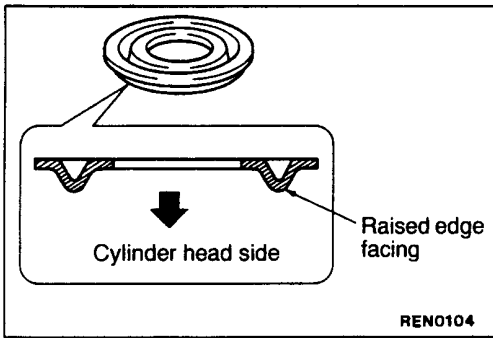

15. Fit new heat shield in the cylinder head with the raised edge facing towards the swirl chamber.
16. Attach the special tool to the injection nozzle hole and tighten it to the specified torque.

Specified torque: 70 Nm

17. Install the fuel return hoses.
18. Connect the needle lift sensor connector.
19. Connect the fuel injection pipe.
20. Connect fuel cut solenoid valve (immobilizer) connector.
21. Erase the diagnosis code using the MUT-II if the engine warning lamp illuminate.

TIMING BELT TENSION ADJUSTMENT

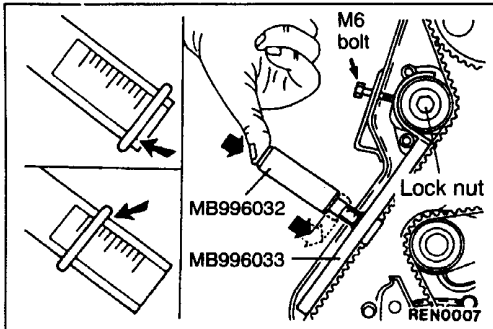

1. Remove the timing belt cover.
2. Turn the crankshaft clockwise to set the No.1 cylinder to top dead compression centre.
3. Slacken the lock nut of the timing belt tensioner.
4. Fit the special tool on the timing belt and the timing belt tensioner.
5. Tension the timing belt with the aid of an M6 bolt.

Standard value: 7.5 mm

6. Tighten the lock nut to the specified torque.

Specified torque: 50 Nm

7. Install the timing belt cover.

CRANKSHAFT PULLEY

REMOVAL AND INSTALLATION

Pre-removal Operation

- Under Cover Removal

Post-installation Operation

- Drive Belt Tension Adjustment
- Under Cover Installation

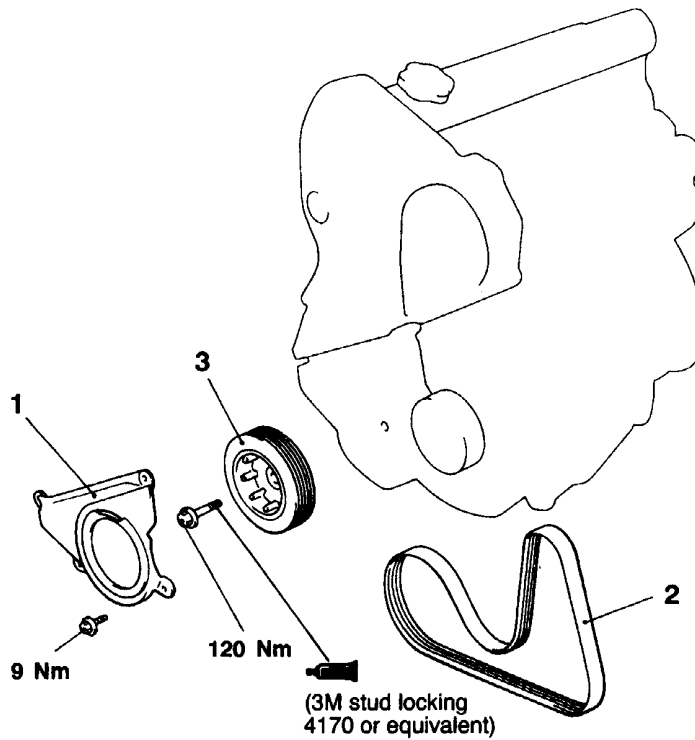

Removal steps

1. Timing belt front cover C
2. Drive belt
3. Crankshaft pulley

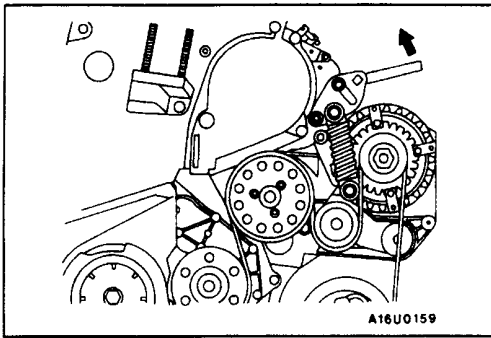

**REMOVAL SERVICE POINTS****◀A▶ DRIVE BELT REMOVAL <Vehicles with A/C>**

1. Place a ratchet spanner in the alternator brace.
2. Maintain pressure on the ratchet spanner and slacken the bolts.
3. Slowly reduce the drive belt tension and then remove the belt.

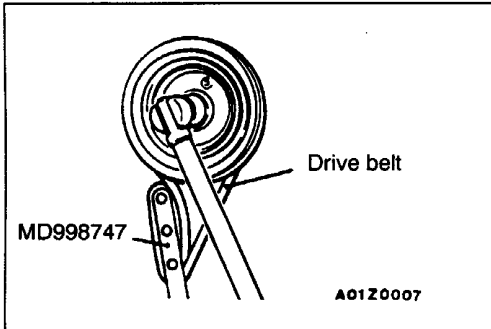
**◀B▶ CRANKSHAFT PULLEY REMOVAL****Caution**

1. This drive belt will get damaged. Do not use the engine's drive belt.
2. Never use a damaged drive belt.

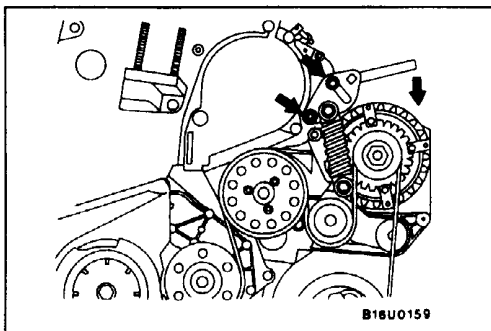
**INSTALLATION SERVICE POINT****▶A◀ DRIVE BELT INSTALLATION <Vehicles with A/C>**

1. Place the drive belt around the pulleys.
2. Insert the ratchet spanner in the alternator brace and tension the drive belt, checking that the belt is properly fitted in the grooves.
3. Tighten the two bolts.

CAMSHAFT AND CAMSHAFT OIL SEAL

REMOVAL AND INSTALLATION

Pre-removal and Post-installation Operation
 (1) Engine Coolant Draining and Supplying
 (2) Timing Belt Removal and Installation (Refer to P.11B-30.)

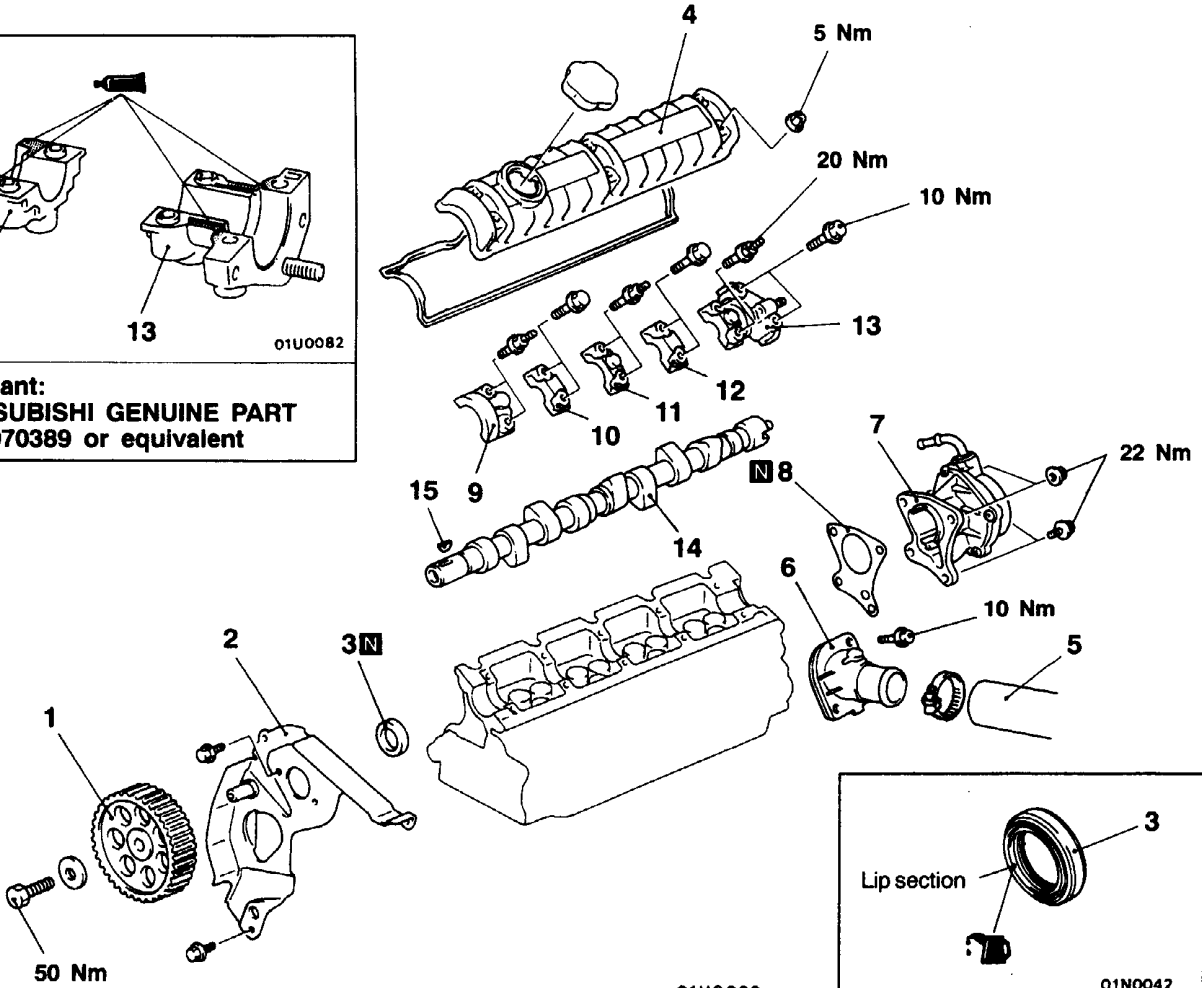
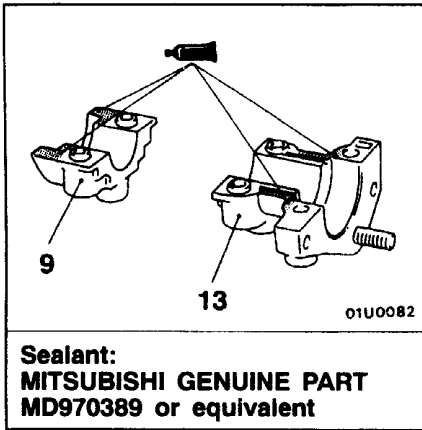

01U0083
 00005135

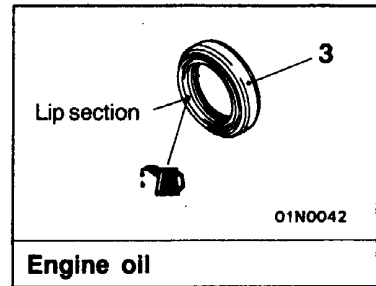

Removal steps

- ◀A▶ 1. Camshaft sprocket
- ▶A▶ 2. Timing belt under cover upper
- ▶A▶ 3. Camshaft oil seal
- ▶A▶ 4. Rocker cover
- ▶A▶ 5. Radiator upper hose connection
- ▶A▶ 6. Water inlet fitting
- ▶A▶ 7. Vacuum pump
- ▶A▶ 8. Gasket

- 9. No.1 camshaft bearing cap
- 10. No.2 camshaft bearing cap
- 11. No.3 camshaft bearing cap
- 12. No.4 camshaft bearing cap
- 13. No.5 camshaft bearing cap
- 14. Camshaft
- 15. Key

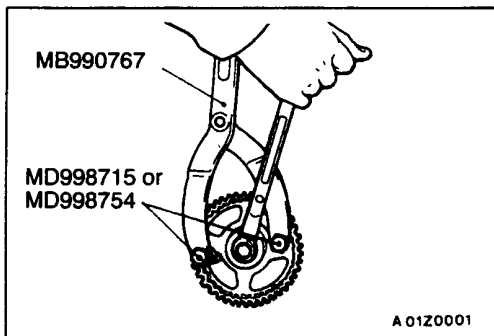

REMOVAL SERVICE POINT

◀A▶ CAMSHAFT SPROCKET REMOVAL

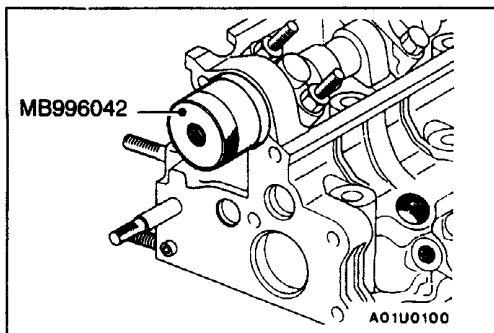

INSTALLATION SERVICE POINT

▶A◀ CAMSHAFT OIL SEAL INSTALLATION

1. Coat the lip of the oil seal with a thin layer of engine oil.
2. Tape off the camshaft.
3. Locate the oil seal over the camshaft.
4. Fit the oil seal with the special tool.

OIL PAN

REMOVAL AND INSTALLATION

Pre-removal and Post-installation Operation

- (1) Engine Oil Draining and Supplying
- (2) Oil Level Gauge Removal and Installation
- (3) Under Cover Removal and Installation
- (4) Drive Shaft (RH) Removal and Installation

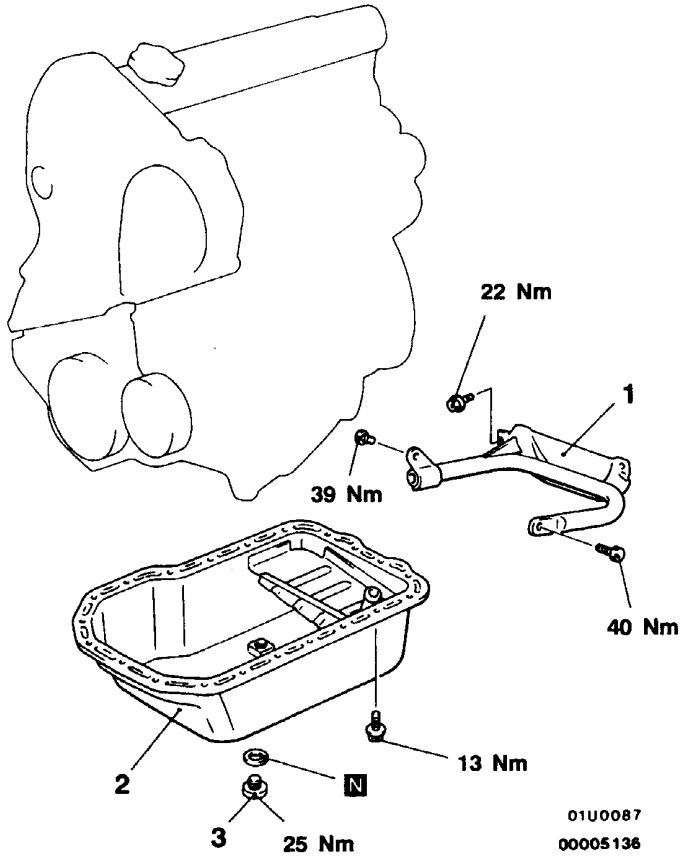
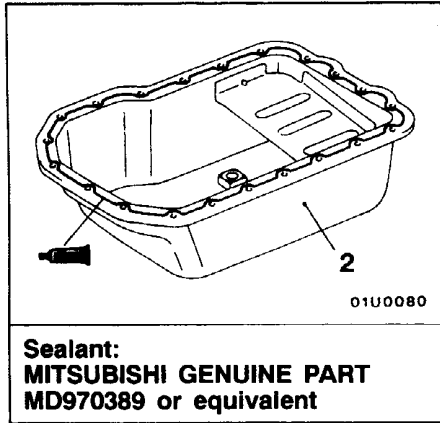

Removal steps

- ◀A▶ 1. Bending strut
- ▶A◀ 2. Oil pan
- ▶A◀ 3. Drain plug

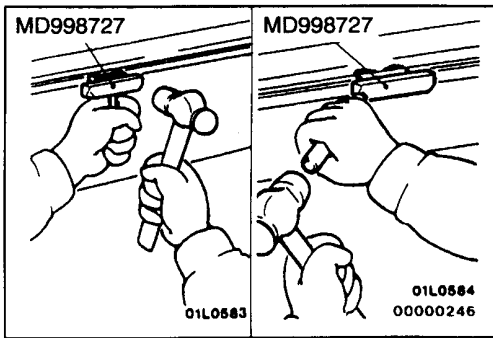

REMOVAL SERVICE POINT

◀A▶ OIL PAN REMOVAL

After removing the oil pan mounting bolts, remove the oil pan with the special tool and a brass bar.

Caution

Perform this slowly to avoid deformation of the oil pan flange.

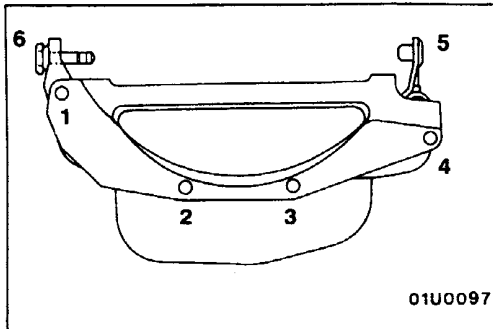

INSTALLATION SERVICE POINT

▶A◀ BENDING STRUT INSTALLATION

1. Provisionally tighten the bending strut mounting screws in the order 1, 2, 3, 4, 5 and 6.
2. After the screws have been provisionally tightened, tighten them to the specified torque in the order 5, 1, 2, 3, 4 and 6.

**CRANKSHAFT OIL SEAL
REMOVAL AND INSTALLATION**

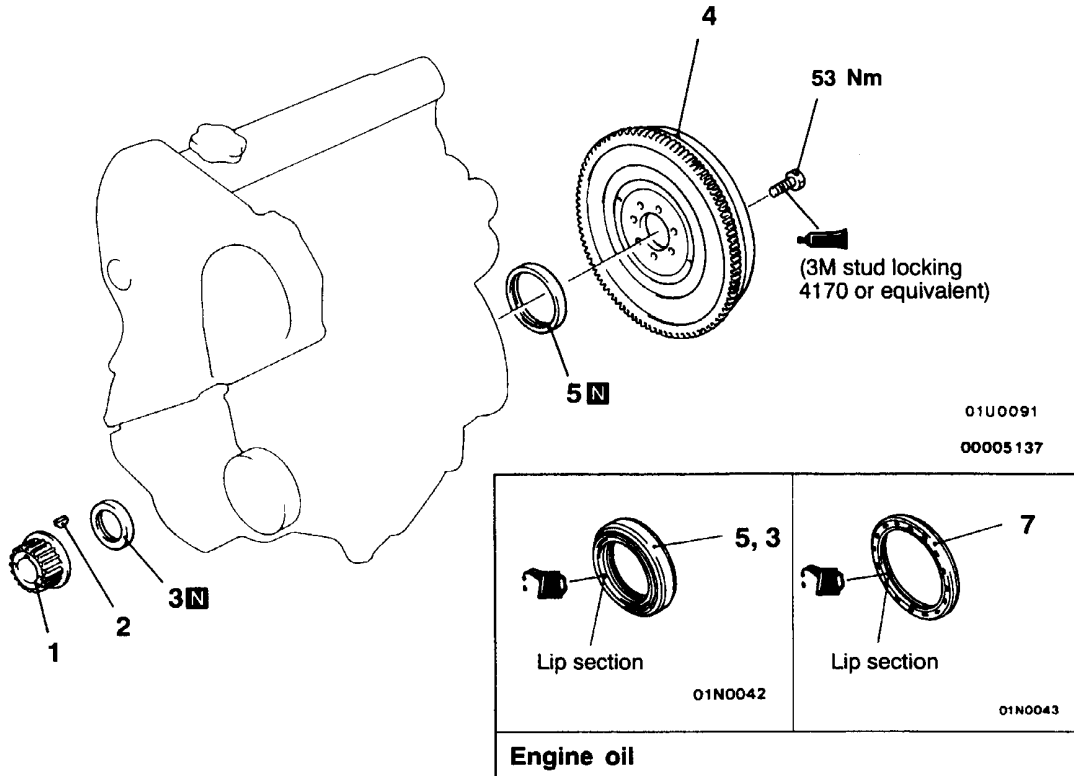

01U0091
00005137

Crankshaft front oil seal removal steps

- Timing belt (Refer to P.11B-30.)
- 1. Crankshaft sprocket
- 2. Key
- 3. Crankshaft front oil seal



Crankshaft rear oil seal removal steps

- Transmission assembly (Refer to GROUP 22.)
- Clutch cover and disc
- 4. Flywheel assembly
- 5. Crankshaft rear oil seal

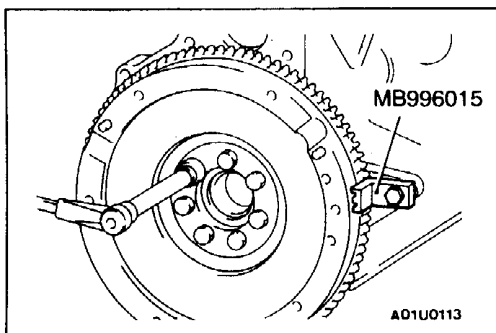

REMOVAL SERVICE POINT

◀B▶ FLYWHEEL ASSEMBLY REMOVAL

Use the special tool to secure the flywheel and remove the bolts.

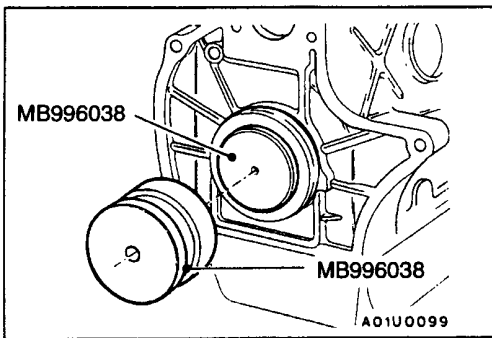

INSTALLATION SERVICE POINTS

►A◄ CRANKSHAFT REAR OIL SEAL INSTALLATION

1. Coat the lip of the oil seal with a thin layer of engine oil.
2. Locate the special tool (installer guide) over the crankshaft.
3. Locate the oil seal over the guide.
4. Fit the oil seal with special tool (installer).

►B◄ FLYWHEEL ASSEMBLY INSTALLATION

1. Clean off all sealant, oil and other substances which are adhering to the threaded bolts, crankshaft thread holes and the flywheel.
2. Apply sealant to the threaded mounting bolts.

Specified sealant: 3M Stud locking 4170 or equivalent

3. Use the special tool to secure the flywheel, and then tighten the bolts to the specified torque.

Tightening torque: 53 Nm

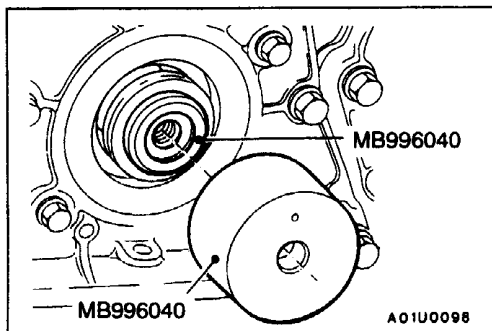

►C◄ CRANKSHAFT FRONT OIL SEAL INSTALLATION

1. Coat the lip of the oil seal with a thin layer of engine oil.
2. Locate the special tool (installer guide) over the crankshaft.
3. Locate the oil seal over the guide.
4. Fit the oil seal with special tool (installer).

INTERMEDIATE SHAFT OIL SEAL

REMOVAL AND INSTALLATION

Pre-removal and Post-installation Operation

- Timing Belt Removal and Installation (Refer to P.11B-30.)

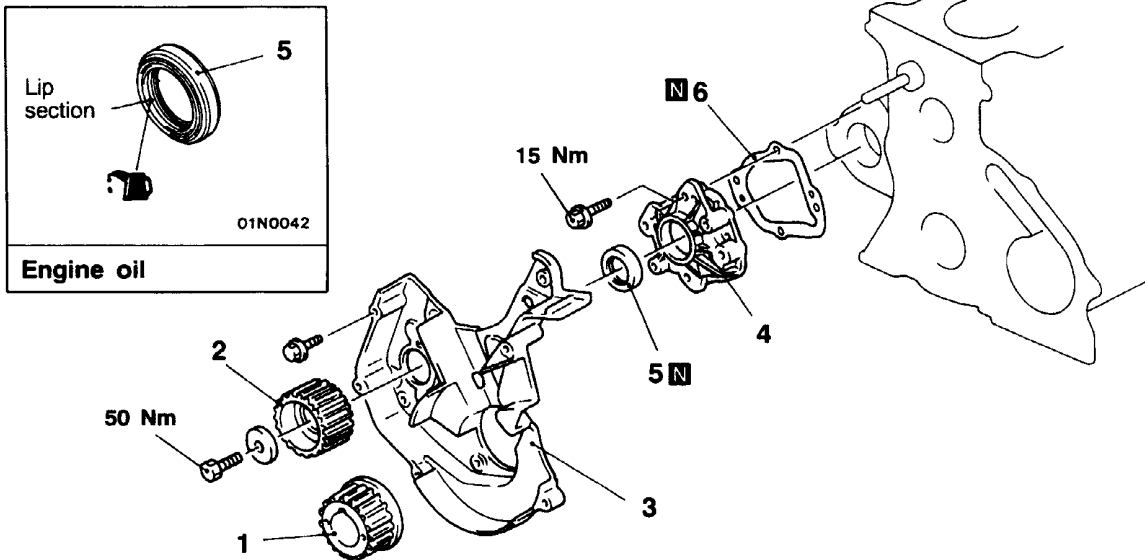

01U0090
00005138

Removal steps



1. Crankshaft sprocket
2. Intermediate shaft sprocket
3. Timing belt under cover lower



4. Intermediate shaft housing
5. Intermediate shaft oil seal
6. Gasket

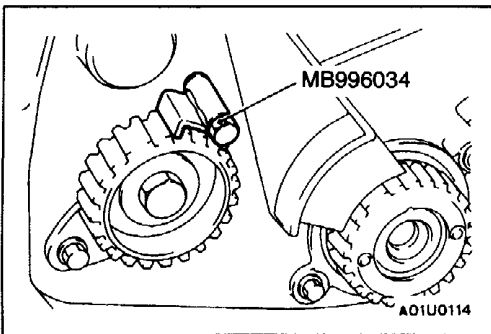

REMOVAL SERVICE POINT

◀▶ INTERMEDIATE SHAFT SPROCKET REMOVAL

Remove the timing sprocket from the intermediate shaft using the special tool.

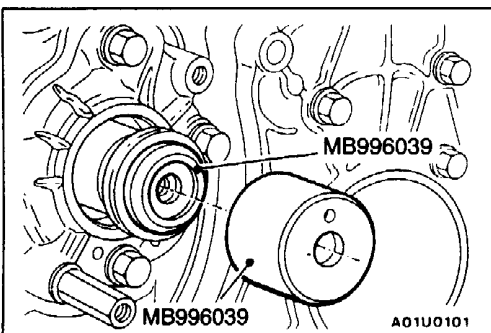

INSTALLATION SERVICE POINT

▶▶ INTERMEDIATE SHAFT OIL SEAL INSTALLATION

1. Coat the lip of the oil seal with a thin layer of engine oil.
2. Locate the special tool (installer guide) over the intermediate shaft.
3. Locate the oil seal over the installer.
4. Fit the oil seal with special tool (installer).

CYLINDER HEAD GASKET

REMOVAL AND INSTALLATION

Pre-removal Operation

- (1) Engine Coolant Draining
- (2) Air Cleaner and Air Intake Hose Removal
- (3) Downpipe Assembly Removal (Refer to GROUP 15.)

Post-Installation Operation

- (1) Downpipe Assembly Installation (Refer to GROUP 15.)
- (2) Throttle Cable Adjustment (Refer to GROUP 17 – Accelerator Cable and Pedal.)
- (3) Air Cleaner and Air Intake Hose Installation
- (4) Engine Coolant Refilling
- (5) Fuel line air bleeding (Refer to GROUP 13E – On-vehicle Service.)

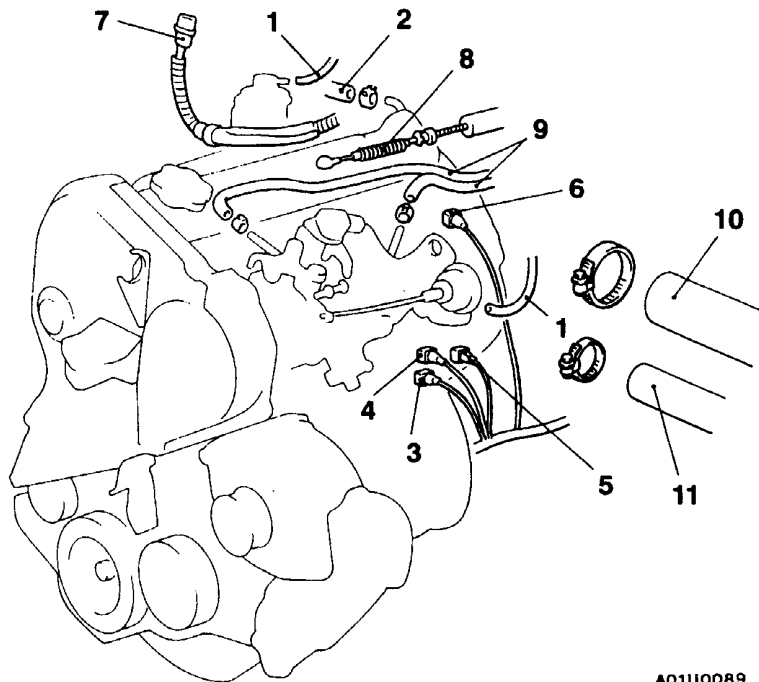

A01U0089

Removal steps

- 1. Vacuum hoses connection
- 2. Brake booster vacuum hose connection
- 3. Load lever sensor connector
- 4. Proportional solenoid connector
- 5. Immobilizer connector
- 6. Needle lift sensor connector
- 7. Glow plug relay connector
- 8. Throttle cable connection
- 9. Fuel hoses connection
- 10. Radiator upper hose connection
- 11. Water hose connection

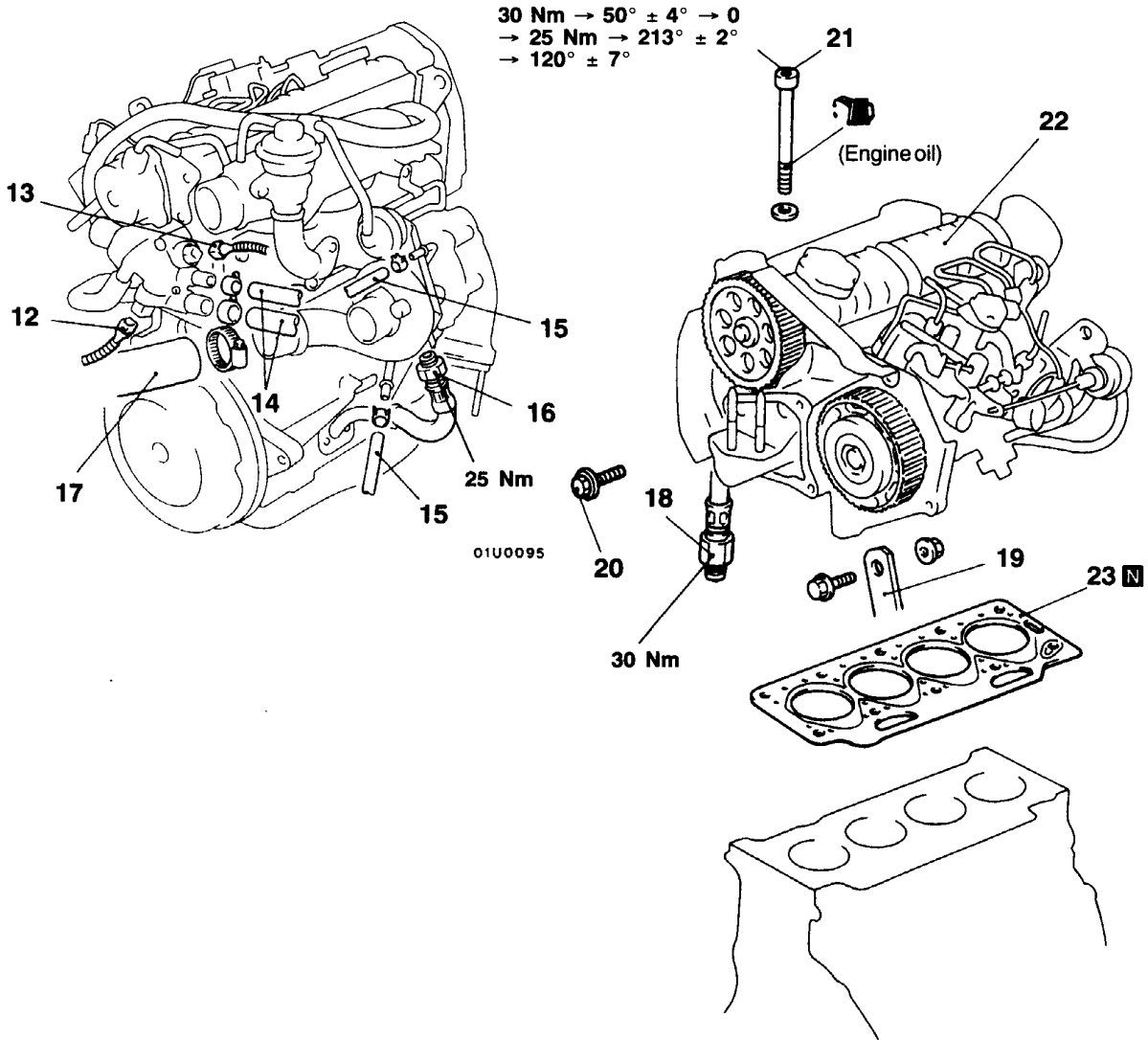

- 12. Engine coolant temperature gauge unit connector
- 13. Engine coolant temperature sensor connector
- 14. Heater hoses connection
- 15. Engine coolant hoses connection
- 16. Oil return pipe assembly connection
- 17. Air hose A connection

- 18. Oil pipe assembly connection
- 19. Turbo support bracket connection
 - Timing belt (Refer to P.11B-30.)
- 20. Timing belt under cover mounting bolt

- ◀A▶ ▶C◀ 21. Cylinder head bolt
- ▶B◀ ▶A◀ 22. Cylinder head assembly
- ▶B◀ ▶A◀ 23. Cylinder head gasket

01U0093
00005139

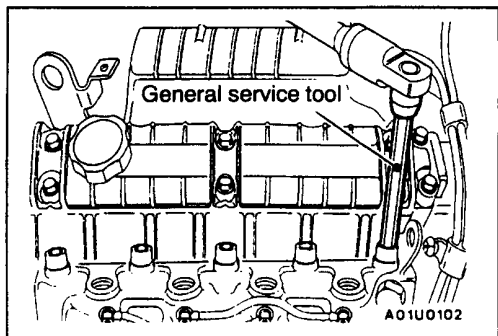

REMOVAL SERVICE POINTS

◀A▶ **CYLINDER HEAD BOLT REMOVAL**

◀B▶ **CYLINDER HEAD GASKET REMOVAL**

Caution

When removing the cylinder head gasket, take care not to scratch the cylinder head or cylinder block gasket faces.

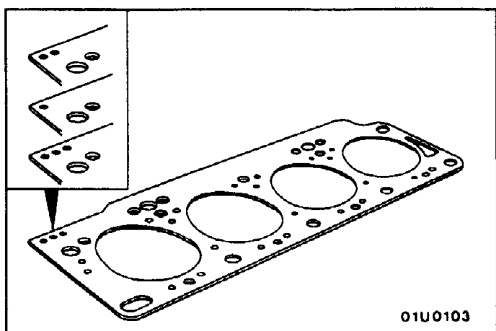

INSTALLATION SERVICE POINTS

▶A▶ **CYLINDER HEAD GASKET INSTALLATION**

Select a cylinder head gasket of the correct thickness according to the projecting height of the pistons. The available cylinder head gaskets are shown in the table below. The thickness of the gasket is indicated by the number of holes near the end of the gasket (see the illustration). Measure the projecting height of the pistons and calculate the average height. Then select a cylinder head gasket of the correct thickness from the table shown below.

Piston height above cylinder block (mm)	Number of holes	Gasket thickness (mm)
0.073 or less	2	1.40
0.073 – 0.206	1	1.50
0.206 or more	3	1.60

If it is only a question of fitting a new gasket, check the hole pattern on the old gasket and select a gasket with the same number of holes.

Caution

If a piston or connecting rod, etc. has been replaced, always measure the projecting height of the pistons because this may have changed after replacing these parts.

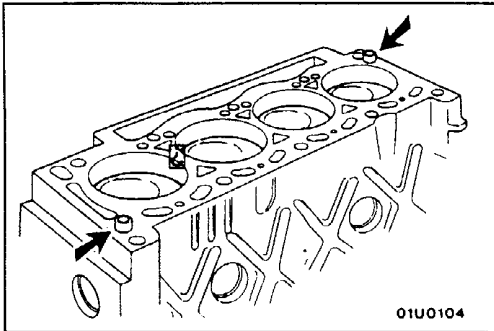
**►B◄ CYLINDER HEAD ASSEMBLY INSTALLATION**

1. Rotate the crankshaft so that the piston of No.1 cylinder is positioned a quarter-stroke past TDC.
2. Fit the cylinder head over the locating dowels.

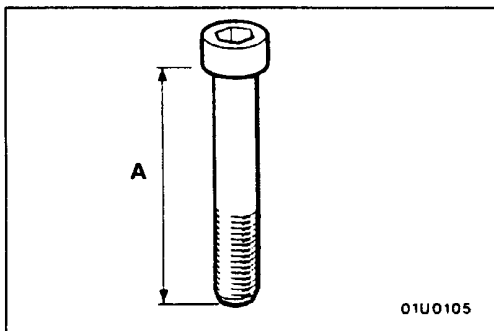
**►C◄ CYLINDER HEAD BOLT INSTALLATION**

1. When installing the cylinder head bolts, check that the length of the shank of each bolt (without the washer) is within the limit value. All the cylinder head bolts must be renewed as soon as any of them exceeds the permitted length.

Limit (A): max. 120.5 mm

2. Fit the washers.
3. Lubricate the bolt threads and washers with engine oil.

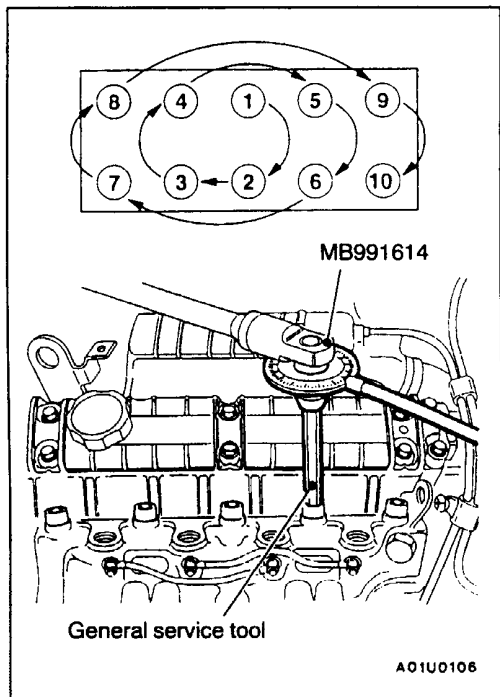

4. Tighten the bolts by the following procedure.

Step	Operation	Remarks
1	Tighten to 30 Nm.	Carry out in the order shown in the illustration.
2	Tighten $50^\circ \pm 4^\circ$ of a turn.	Using the special tool, carry out in the order shown in the illustration.
3	Wait for a minimum of 3 minutes.	-
4	Fully loosen.	Carry out in the reverse order of that shown in the illustration.
5	Tighten to 25 Nm.	Carry out in the order shown in the illustration.
6	Tighten $213^\circ \pm 2^\circ$ of a turn.	Using the special tool, carry out in the order shown in the illustration.
7	Tighten $120^\circ \pm 7^\circ$ of a turn.	After the engine has warmed up, wait until it cools down and then tighten further in the order shown in the illustration.

TIMING BELT

REMOVAL AND INSTALLATION

Pre-removal and Post-installation Operation
 (1) Under Cover (R.H.) Removal and Installation
 (2) Engine Mount Bracket Removal and Installation
 (Refer to GROUP 32.)
 (3) Crankshaft Pulley Removal and Installation (Refer to P.11B-16.)

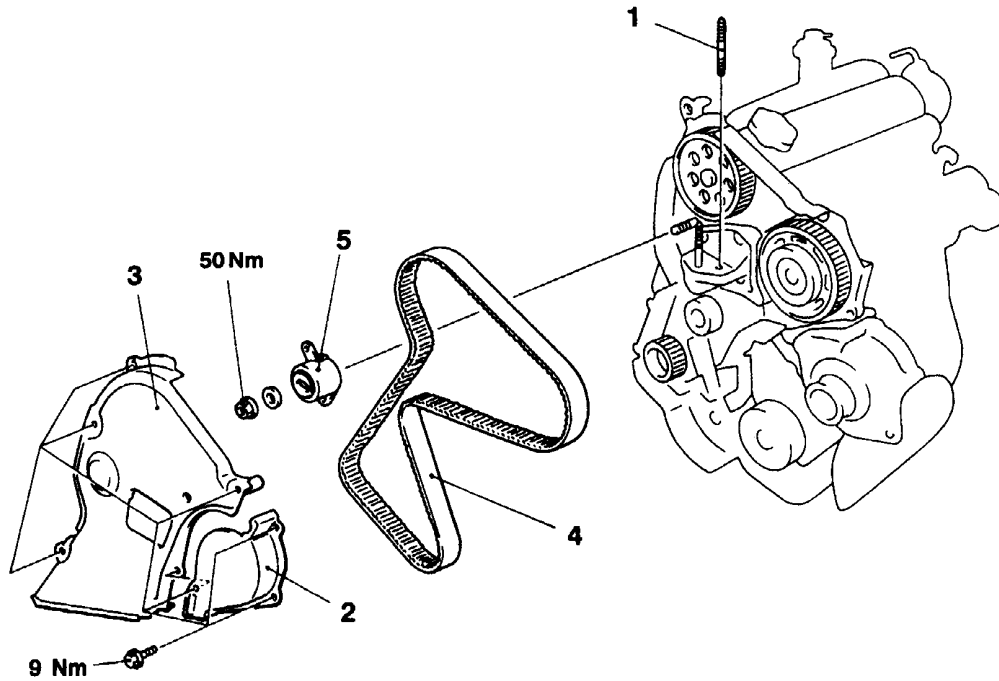

A01U0092

Removal steps

1. Stud bolt
2. Timing belt front cover B
3. Timing belt front cover A
4. Timing belt
5. Tensioner roller



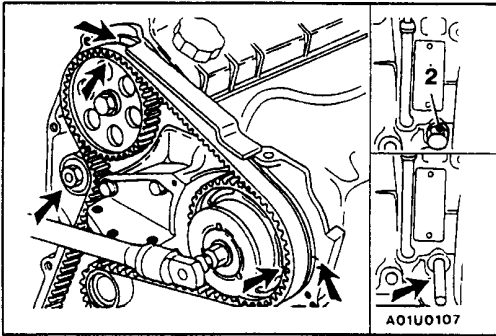

REMOVAL SERVICE POINTS

◀A▶ TIMING BELT REMOVAL

1. Turn the crankshaft clockwise so that the piston of No.1 cylinder (flywheel end) is at TDC, with the following marks in line with each other:
 - flywheel/clutch housing;
 - rear guard plate/camshaft sprocket.
 Scribe a mark on the injection pump mounting bracket.
2. Insert an 8 mm diameter locking pin in the threaded hole of bolt 2 so that it engages the recess in the crankshaft web.
3. Slacken the lock nut of the timing belt tensioner.
4. Remove the timing belt.

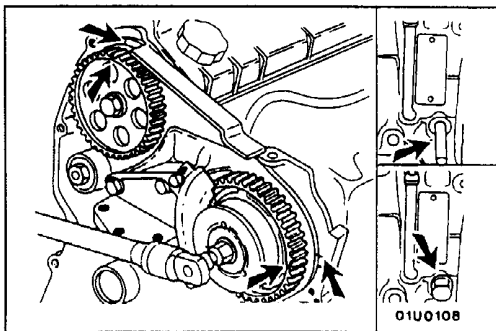

INSTALLATION SERVICE POINTS

▶A◀ TIMING BELT INSTALLATION

1. Turn the camshaft clockwise until the mark on the camshaft sprocket is opposite the mark on the guard plate.
2. Turn the crankshaft 1/4 revolution counter-clockwise from the TDC position of No.1 cylinder and insert the 8 mm diameter locking pin in the recess in the crankshaft web.
3. Align the mark on the injection pump sprocket with the mark on the mounting bracket (turn clockwise).

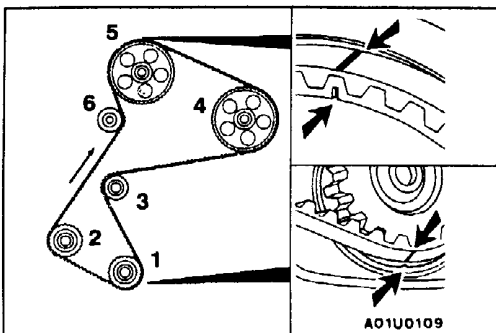

4. Fit the timing belt so that the lines on the belt are aligned with the marks on the crankshaft and camshaft sprockets and the injection pump sprocket.

When fitting the belt, note:

- the direction of rotation of the belt (see the arrows on the belt);
- the sequence in which the belt is fitted around the sprockets.

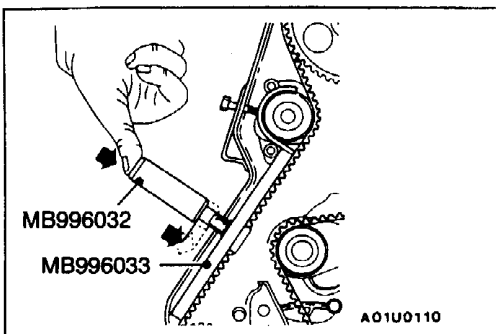

5. Fit the special tool on the timing belt and the timing belt tensioner.
6. Tension the timing belt with the aid of an M6 bolt.
Standard value: 7.5 mm
7. Tighten the lock nut to the specified torque.

ENGINE ASSEMBLY

REMOVAL AND INSTALLATION

- Pre-removal Operations**
- (1) Hood Removal
 - (2) Air Cleaner and Air Intake Hose Removal
 - (3) Intercooler Hose Removal (Refer to GROUP 15.)
 - (4) Radiator Assembly Removal (Refer to GROUP 14.)
 - (5) Under Cover Removal
 - (6) Downpipe Assembly Removal (Refer to GROUP 15.)

- Post-installation Operations**
- (1) Downpipe Assembly Installation (Refer to GROUP 15.)
 - (2) Under Cover Installation
 - (3) Radiator Assembly Installation (Refer to GROUP 14.)
 - (4) Throttle Cable Adjustment (Refer to GROUP 17 - Accelerator Cable and Pedal.)
 - (5) Intercooler Hose Installation (Refer to GROUP 15.)
 - (6) Air Cleaner and Air Intake Hose Installation
 - (7) Hood Installation
 - (8) Evacuation of Air from Fuel Line (Refer to GROUP 13E - On-vehicle Service.)

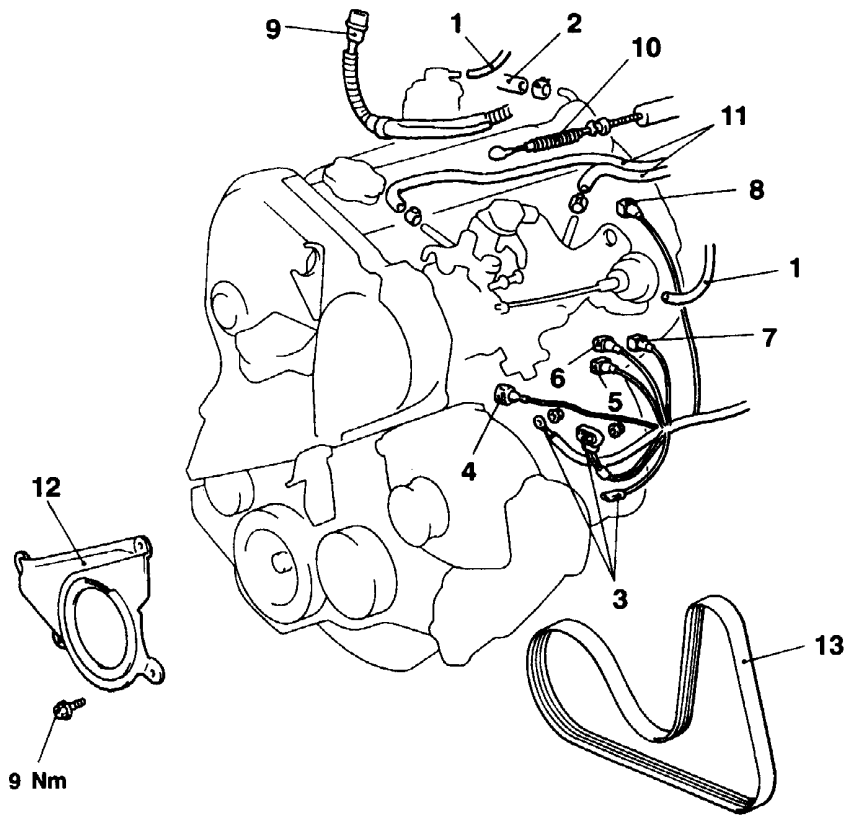

A01U0088

Removal steps

- | | |
|--|--|
| <ol style="list-style-type: none"> 1. Vacuum hoses connection 2. Brake booster vacuum hose connection 3. Alternator connector 4. Oil pressure switch connector 5. Load lever sensor connector 6. Proportional solenoid connector 7. Immobilizer connector | <ol style="list-style-type: none"> 8. Needle lift sensor connector 9. Glow plug relay connector 10. Throttle cable connection 11. Fuel hoses connection 12. Timing belt front cover C <ul style="list-style-type: none"> ● Drive belt tension adjustment (Refer to P.11B-7.) 13. Drive belt (Refer to P.11B-16.) |
|--|--|

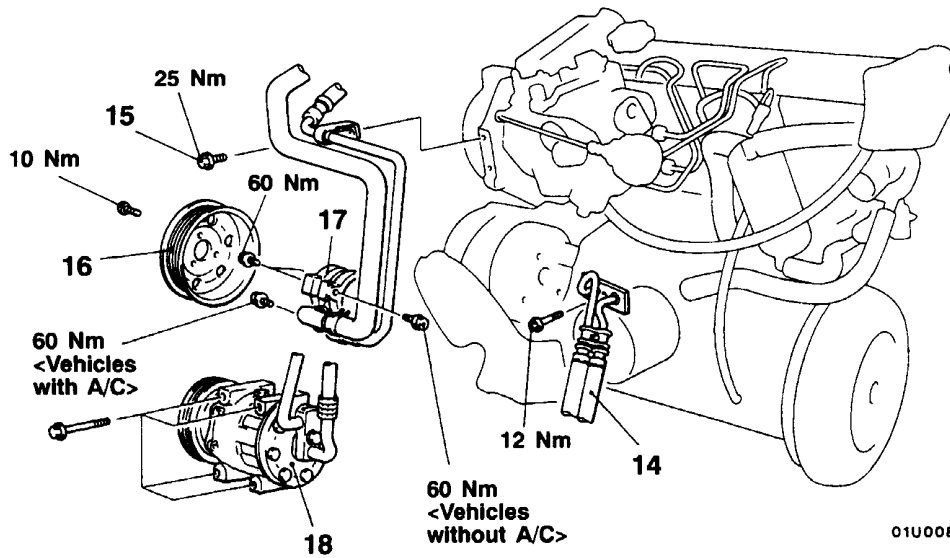

01U0084

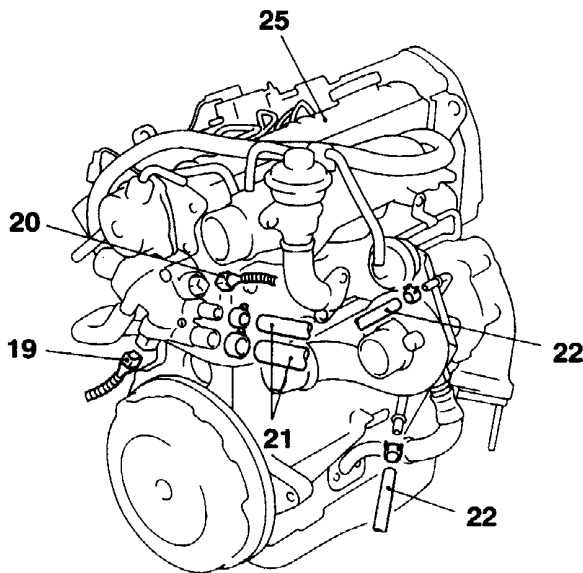

01U0094

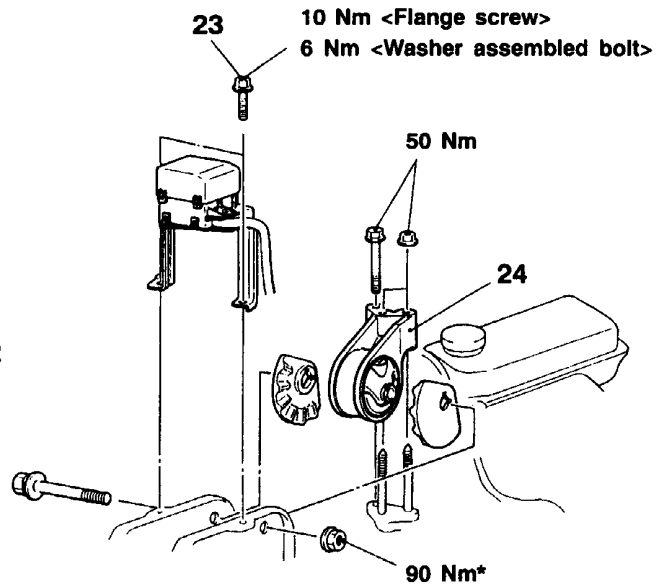

01U0069
00005141



- 14. Engine oil cooler hose connection <vehicles with A/C>
- 15. Bolt <vehicles without A/C>
- 16. Power steering pump pulley
- 17. Power steering oil pump
- 18. A/C compressor
- 19. Engine coolant temperature gauge unit connector
- 20. Engine coolant temperature sensor connector
- 21. Heater hoses connection
- 22. Engine coolant hoses connection

- Transmission assembly (Refer to GROUP 22.)

- 23. Bolts <vehicles with A/C>
- 24. Engine mount bracket
- 25. Engine assembly

Caution
Mounting locations marked by * should be provisionally tightened, and then fully tightened when the body is supporting the full weight of the engine.

REMOVAL SERVICE POINTS**◀A▶ POWER STEERING OIL PUMP REMOVAL**

Remove the power steering oil pump from the bracket with the hose attached.

NOTE

Place the removed power steering oil pump where it will not be a hindrance when removing and installing the engine assembly, and tie it with a cord.

◀B▶ A/C COMPRESSOR REMOVAL

Disconnect the A/C compressor connector and remove the compressor from the compressor bracket with the hose still attached.

NOTE

Place the removed A/C compressor where it will not be a hindrance when removing and installing the engine assembly, and tie it with a cord.

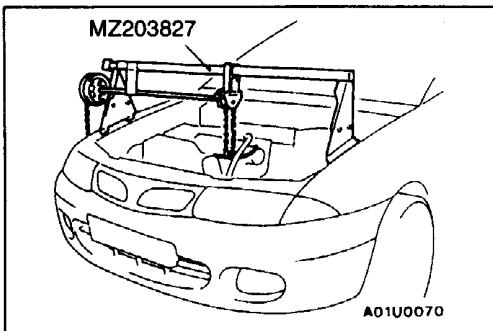
**◀C▶ ENGINE MOUNT BRACKET REMOVAL**

1. Support the engine with a garage jack.
2. Remove the special tool which was attached when the transmission assembly was removed.
3. Hold the engine assembly with a chain block or similar tool.
4. Place a garage jack against the engine oil pan with a piece of wood in between, jack up the engine so that the weight of the engine is no longer being applied to the engine mount bracket, and then remove the engine mount bracket.

◀D▶ ENGINE ASSEMBLY REMOVAL

After checking that all cables, hoses and harness connectors, etc., are disconnected from the engine, lift the chain block slowly to remove the engine assembly upward from the engine compartment.

INSTALLATION SERVICE POINTS**▶A◀ ENGINE ASSEMBLY INSTALLATION**

Install the engine assembly, checking that the cables, hoses, and harness connectors are not clamped.

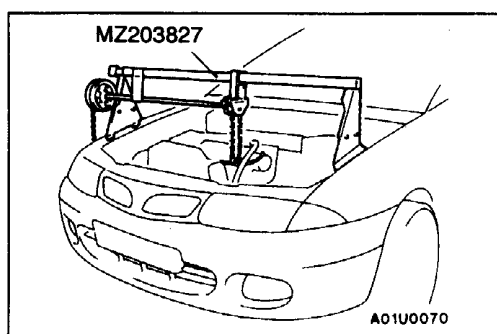
**▶B◀ ENGINE MOUNT BRACKET INSTALLATION**

1. Place a garage jack against the engine oil pan with a piece of wood in between, and install the engine mount bracket while adjusting the position of the engine.
2. Support the engine with the garage jack.
3. Remove the chain block and support the engine assembly with the special tool.