ENGINE AND EMISSION CONTROL

CONTENTS

ENGINE CONTROL SYSTEM	2	SERVICE SPECIFICATIONS	4
GENERAL	2	EXHAUST GAS RECIRCULATION (EGR) SYSTEM	5
Outline of Change	2	General Information	5
ACCELERATOR CABLE AND PEDAL	2	Exhaust Gas Recirculation (EGR) Control System Check	6
EMISSION CONTROL SYSTEM	4	EGR Valve Check	6
GENERAL	4	EGR Solenoid Valve Check	7
Outline of Change	4	Check At The Engine-ECU Terminals	7
GENERAL INFORMATION	4	CATALYTIC CONVERTER	8

ENGINE CONTROL SYSTEM

GENERAL

OUTLINE OF CHANGE

- The service procedure for the throttle cable has been added to correspond to the addition of the diesel-powered vehicle.

Applicable models: 1900D

ACCELERATOR CABLE AND PEDAL

REMOVAL AND INSTALLATION

<L.H. drive vehicles>

<R.H. drive vehicles>

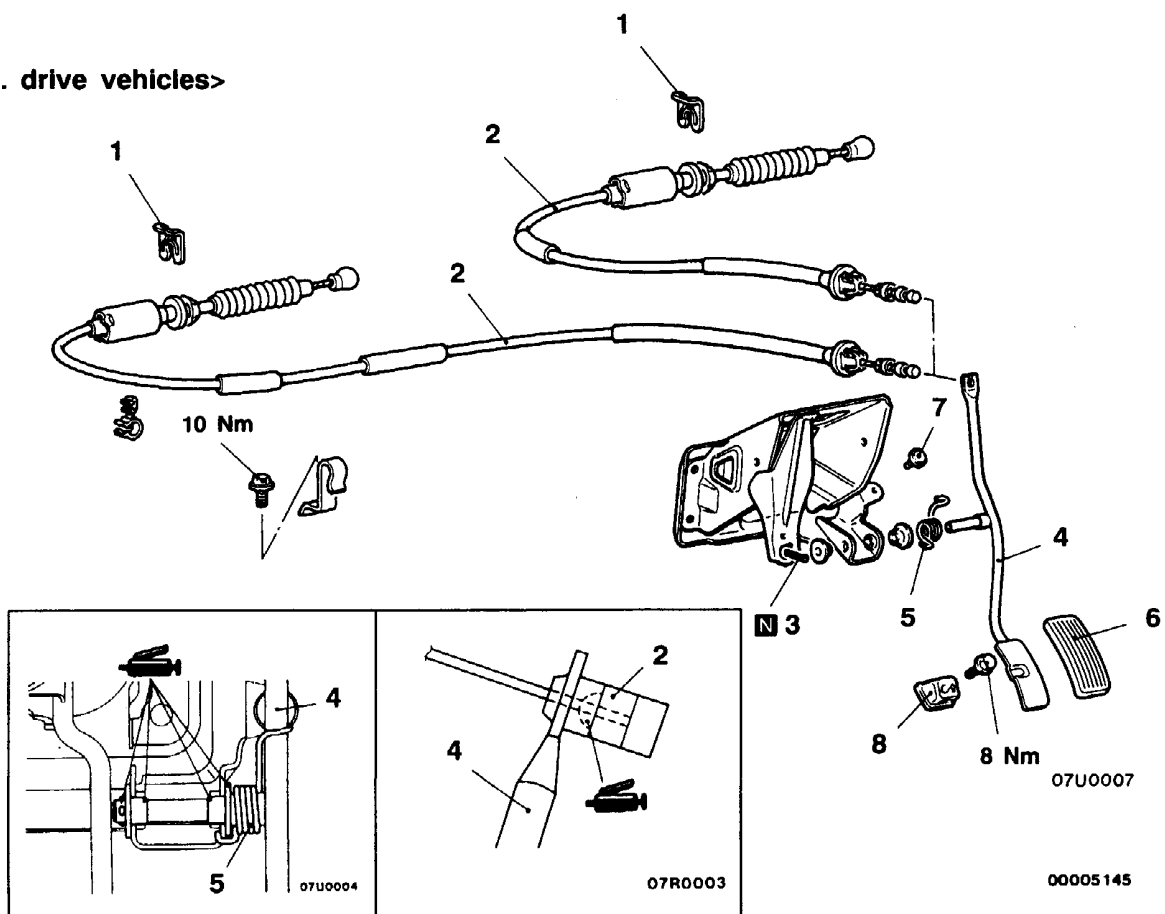

Removal steps

- ▶◀
- Clip
 - Throttle cable
 - Split pin
 - Accelerator pedal

- Spring
- Pedal pad
- Stopper
- Accelerator pedal stopper

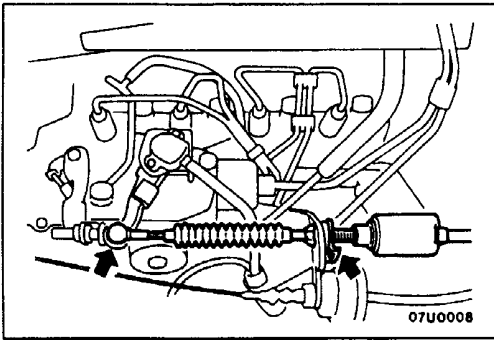

INSTALLATION SERVICE POINT

▶A◀ THROTTLE CABLE INSTALLATION

- (1) Press the throttle cable over the ball of the lever.
- (2) Tension the cable until it has a clearance of about 1 mm and then fit the retaining clip.

EMISSION CONTROL SYSTEM

GENERAL

OUTLINE OF CHANGE

The following maintenance service points have been established to correspond to the adoption of the F8QT engine.

Applicable models: 1900D

GENERAL INFORMATION

The electronically-controlled EGR system and the electronically-controlled fuel injection timing control system reduce the level of exhaust gases (NOx).

Items	Name	Specification
Exhaust emission control system	Exhaust gas recirculation system <ul style="list-style-type: none">• EGR valve• EGR solenoid valve	Electronically-controlled EGR system Single type Duty cycle solenoid valve

SERVICE SPECIFICATIONS

Items	Standard value
EGR solenoid valve resistance (at 23°C) Ω	5 - 6

EXHAUST GAS RECIRCULATION (EGR) SYSTEM

GENERAL INFORMATION

The electronically-controlled EGR system consists of an EGR valve, vacuum pump, EGR solenoid valve, engine-ECU and various sensors. The EGR valve is controlled by the negative pressure inside the valve, which is controlled by EGR solenoid valve.

The EGR solenoid valve is optimally controlled by the engine-ECU in response to the engine operation conditions, based on data input from each of the sensors. In this way, the EGR valve is controlled to reduce NOx emissions while maintaining good engine performance.

SYSTEM DIAGRAM

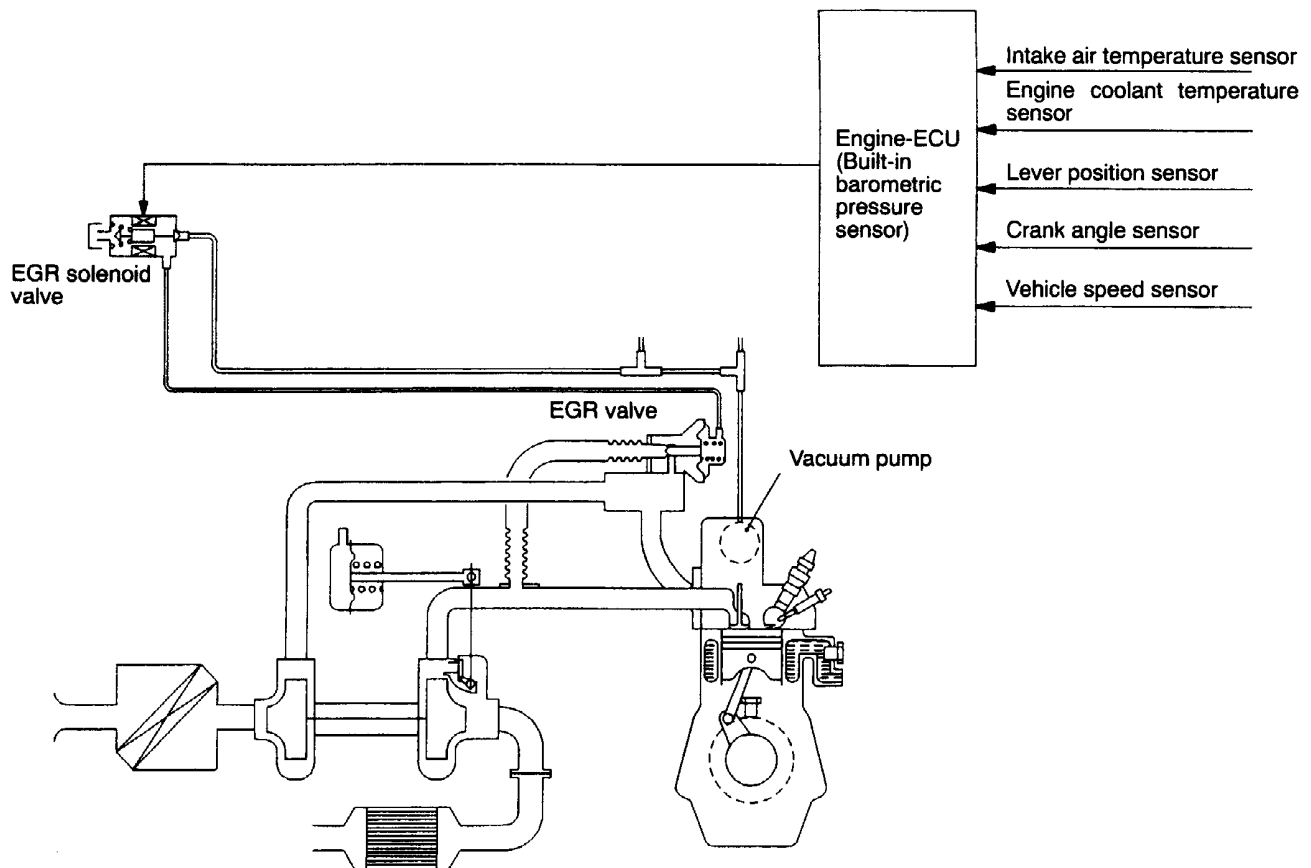

REM0001

COMPONENT LOCATION

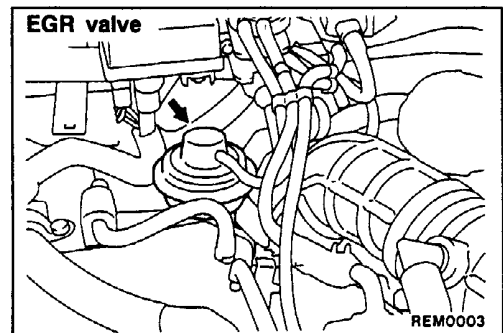
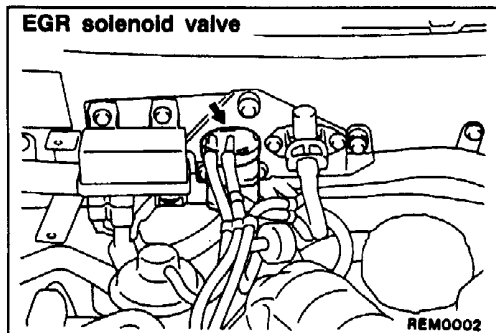

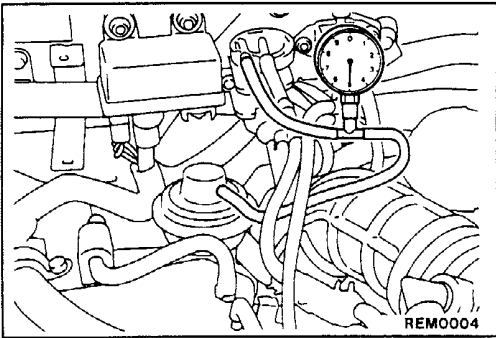

EXHAUST GAS RECIRCULATION (EGR) CONTROL SYSTEM CHECK

1. Disconnect the vacuum hose from the EGR valve, and then connect a hand vacuum pump via the three-way terminal.
2. When the engine is cold and hot, check the condition of vacuum.

When engine is cold
(Engine coolant temperature: 30°C or less)

Engine condition	Normal vacuum condition
Idling	No vacuum will generate
2,500 r/min	

When engine is hot
(Engine coolant temperature: 80°C or higher)

Engine condition	Normal vacuum condition
Idling	Approx. 75 kPa of negative pressure is generated
2,500 r/min	Negative pressure momentarily drops

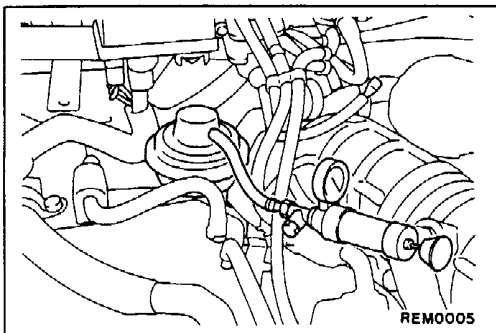

EGR VALVE CHECK

1. Connect a hand vacuum pump to the EGR valve nipple.
2. Apply 53 kPa of vacuum, and check that the vacuum is maintained.
 If the vacuum is not maintained, replace the EGR valve.
3. Check that the sound of the valve closing can be heard when a vacuum leaks.
4. If no sound can heard, remove and inspect the EGR valve.

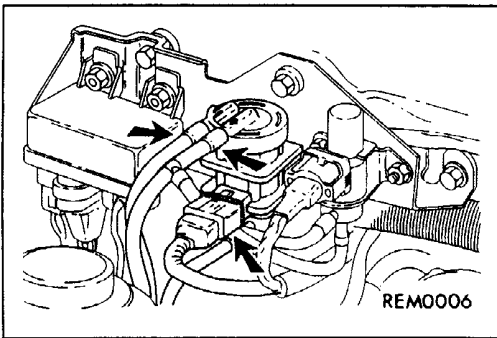

EGR SOLENOID VALVE CHECK

1. Disconnect the vacuum hose from the solenoid valve.
2. Disconnect the harness connector.

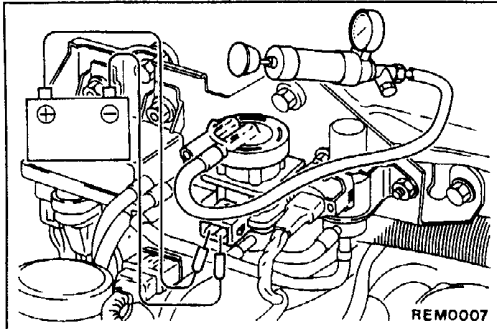

3. Connect a hand vacuum pump to the nipple A.
4. Check air-tightness by applying a vacuum with voltage applied directly from the battery to the EGR solenoid valve and without applying voltage.

Battery voltage	Normal condition
Applied	Vacuum leaks
Not applied	Vacuum maintained

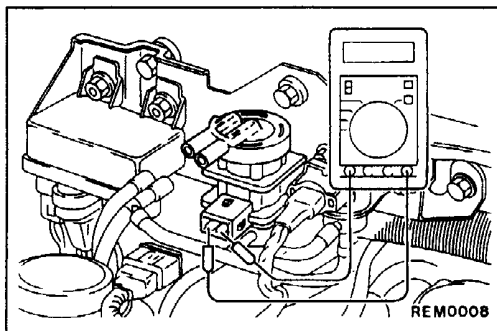

5. Measure the resistance between the terminals of the solenoid valve.

Standard value: 5 – 6 Ω (at 23°C)

CHECK AT THE ENGINE-ECU TERMINALS

TERMINAL VOLTAGE CHECK CHART

Refer to GROUP 13E – Troubleshooting.

CATALYTIC CONVERTER

REMOVAL AND INSTALLATION

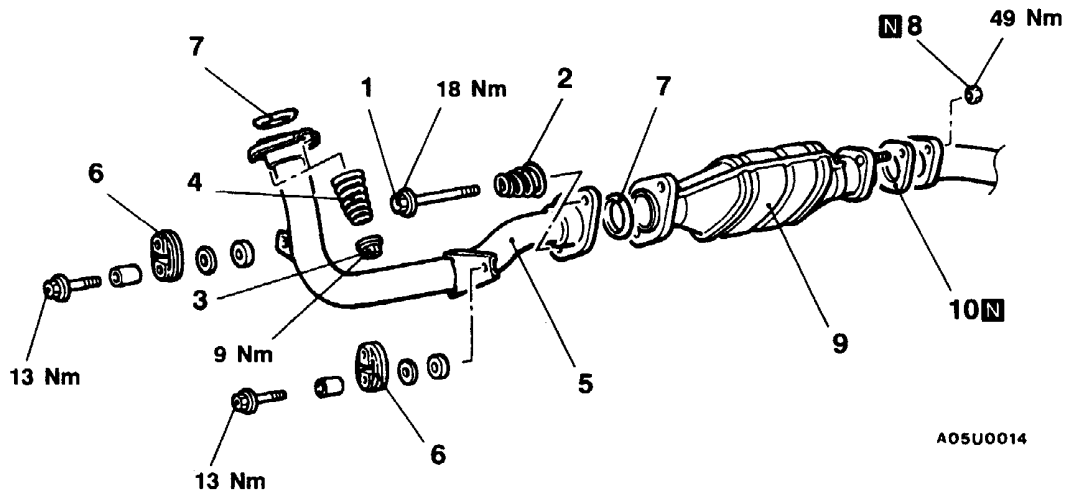

Removal steps

1. Flanged shoulder bolts
2. Conical spring
3. Flange nuts
4. Spring
5. Downpipe assembly

6. Hanger
7. Sealing ring
8. Self locking nuts
9. Catalytic converter
10. Gasket