

GROUP 54

CHASSIS ELECTRICAL

GENERAL

OUTLINE OF CHANGES

- The removal service point for the headlamp (L.H.) has been added to correspond to the addition of the diesel-powered vehicle.
Applicable models: 1900D <Vehicles with air conditioner>
- The troubleshooting for the immobilizer system has been added to correspond to the addition of the diesel-powered vehicle.
Applicable models: 1900D
- The following service procedures have been added to correspond to the addition of the 4-door sedan.
 1. Removal and installation of the rear combination lamp and rear lid lamp
 2. Removal and installation of the high-mounted stop lamp
 3. Removal and installation of the rear speakers
- The troubleshooting section has been changed to correspond to the addition of the diagnosis code No.33 to the immobilizer system.
Applicable models: Petrol-powered vehicles

HEADLAMP

REMOVAL SERVICE POINT

Observe the following procedure to remove the headlamp (L.H.) on vehicles with air conditioner.

1. Remove the upper insulator of the radiator.
2. Move the upper part of the radiator towards the rear of the vehicle to remove the headlamp (L.H.) mounting nut.

IMMOBILIZER SYSTEM

TROUBLESHOOTING

<Petrol-powered vehicles>

INSPECTION CHART FOR DIAGNOSIS CODES

Diagnosis code No.	Inspection items	Reference page
11*	Transponder communication system	-
12*	ID code are not the same or are not registered	-
21	Communication system between immobilizer-ECU and engine-ECU	-
31	EEPROM abnormality inside immobilizer-ECU	-
33*	Starting prevention system activated due to incorrect operation	54-2

NOTE

(1) *: Diagnosis codes No.11, No.12 and No.33 are not recorded.

(2) Refer to the Basic Manual for the inspection procedures of diagnosis code Nos.11, 12, 21 and 31.

INSPECTION PROCEDURE FOR DIAGNOSIS CODES

Code No.33 Starting prevention system activated due to incorrect operation	Probable cause
If the transponder ID code mismatches five times in succession, this code will be output. This code can be canceled by turning the ignition switch ON, and then turning it OFF after 16 minutes have passed.	<ul style="list-style-type: none"> • Malfunction of the immobilizer-ECU • Malfunction of the transponder

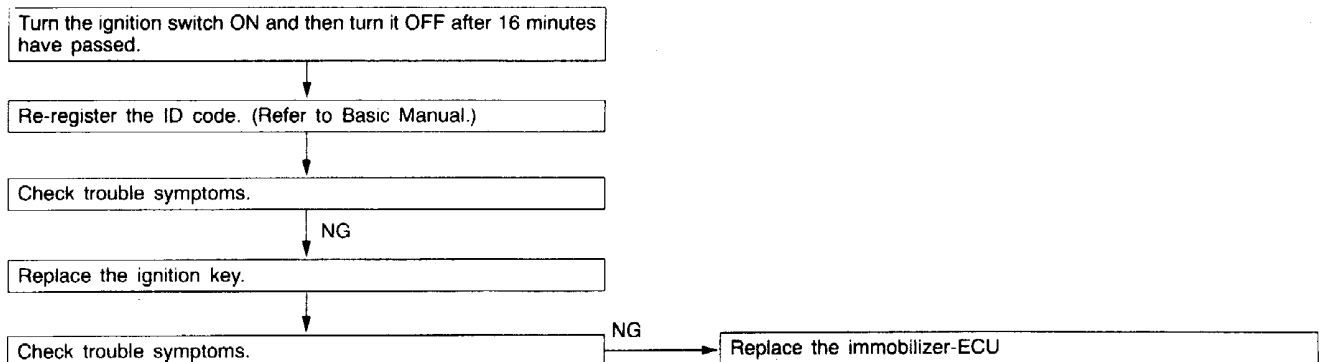

INSPECTION CHART FOR TROUBLE SYMPTOMS

Refer to Basic Manual.

INSPECTION PROCEDURE FOR TROUBLE SYMPTOMS

Refer to Basic Manual.

<Diesel-powered vehicles>

INSPECTION CHART FOR DIAGNOSIS CODES

Diagnosis code No.	Inspection items	Reference page
11*	Transponder communication system	-
12*	ID code are not the same or are not registered	-
21	Communication system between immobilizer-ECU and fuel injection pump	54-3
31	EEPROM abnormality inside immobilizer-ECU	-
33*	Starting prevention system activated due to incorrect operation	54-4

NOTE

- (1) *: Diagnosis codes No.11, No.12 and No.33 are not recorded.
- (2) Refer to the Basic Manual for the inspection procedures of diagnosis code Nos.11, 12 and 31.

INSPECTION PROCEDURE FOR DIAGNOSIS CODES

Code No.21 Communication system between immobilizer-ECU and fuel injection pump	Probable cause
After the ignition switch is turned to the ON position, the confirmation code is not received from the fuel injection pump within the allowable time, or an abnormal code is received.	<ul style="list-style-type: none"> ● Malfunction of harness or connector ● Malfunction of the fuel injection pump ● Malfunction of the immobilizer-ECU

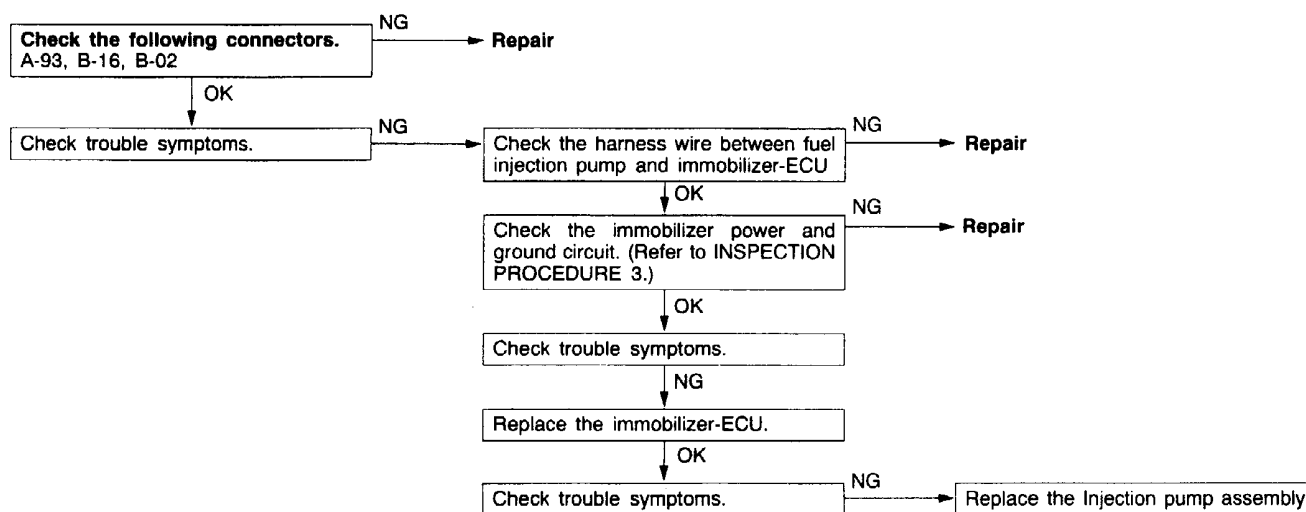

Code No.33 Starting prevention system activated due to incorrect operation	Probable cause
---	-----------------------

If the transponder ID code mismatches five times in succession, this code will be output. This code can be canceled by turning the ignition switch ON, and then turning it OFF after 16 minutes have passed.

- Malfunction of the immobilizer-ECU
- Malfunction of the transponder

Turn the ignition switch ON and then turn it OFF after 16 minutes have passed.

Re-register the ID code. (Refer to Basic Manual.)

Check trouble symptoms.

NG

Replace the ignition key.

Check trouble symptoms.

NG

Replace the immobilizer-ECU

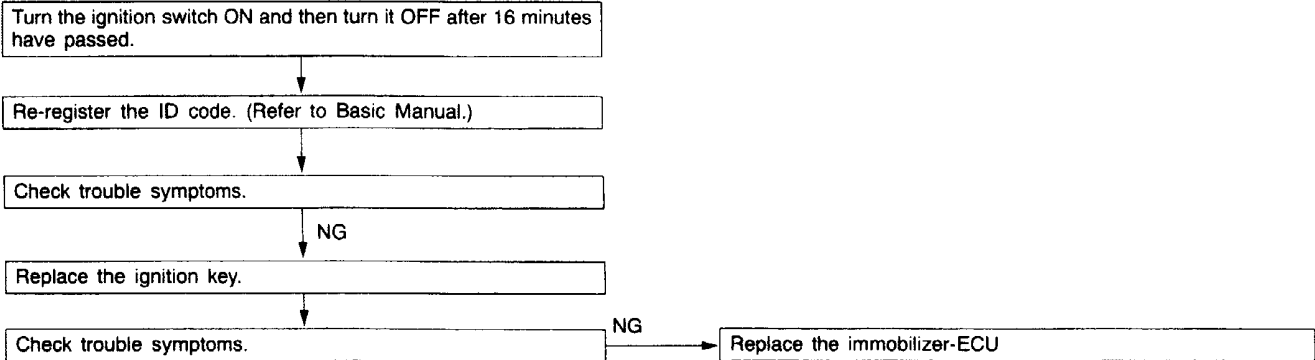

INSPECTION CHART FOR TROUBLE SYMPTOMS

Trouble symptom	Inspection procedure No.	Reference page
Communication with MUT-II is impossible.	1	54-5
ID code cannot be registered using the MUT-II.*	-	-
Engine does not start (Cranking but no initial combustion).	2	54-6
Malfunction of the immobilizer-ECU power source and earth circuit*	-	-

NOTE

For the inspection procedures marked by *, refer to the basic manual.

INSPECTION PROCEDURE FOR TROUBLE SYMPTOMS

Inspection Procedure 1

Communication with MUT-II is impossible.	Probable cause
The cause is probably that a malfunction of the diagnosis line or the immobilizer-ECU is not functioning.	<ul style="list-style-type: none"> ● Malfunction of the diagnosis line ● Malfunction of harness or connector ● Malfunction of the immobilizer-ECU

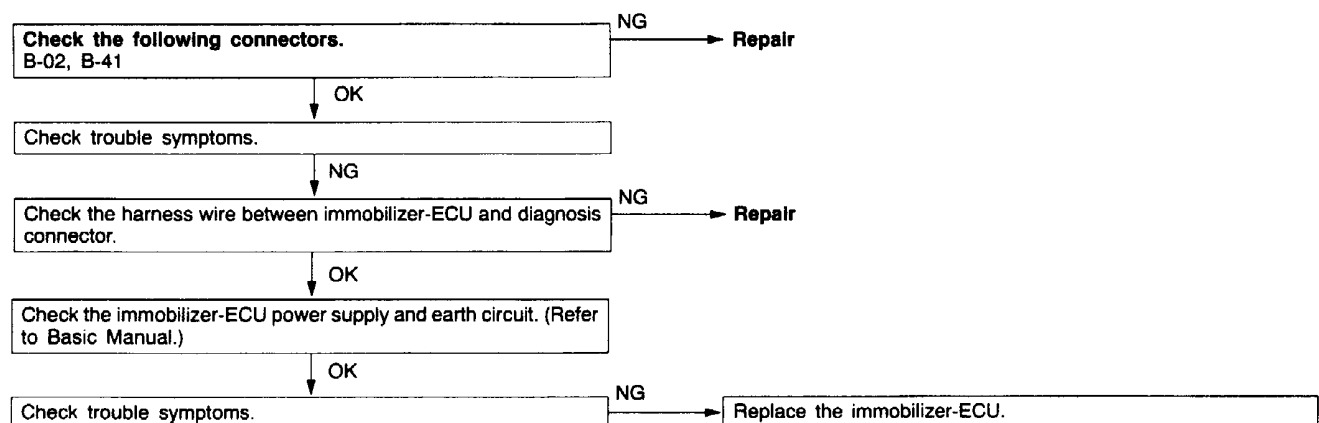

Inspection Procedure 2

Engine does not start (cranking but no initial combustion).	Probable cause
<p>If the fuel injectors are not operating, there might be a problem with the fuel system in addition to a malfunction of the immobilizer system. It is normal for this to occur if an attempt is made to start the engine using a key that has not been properly registered.</p>	<ul style="list-style-type: none"> • Malfunction of the fuel system • Malfunction of the immobilizer system

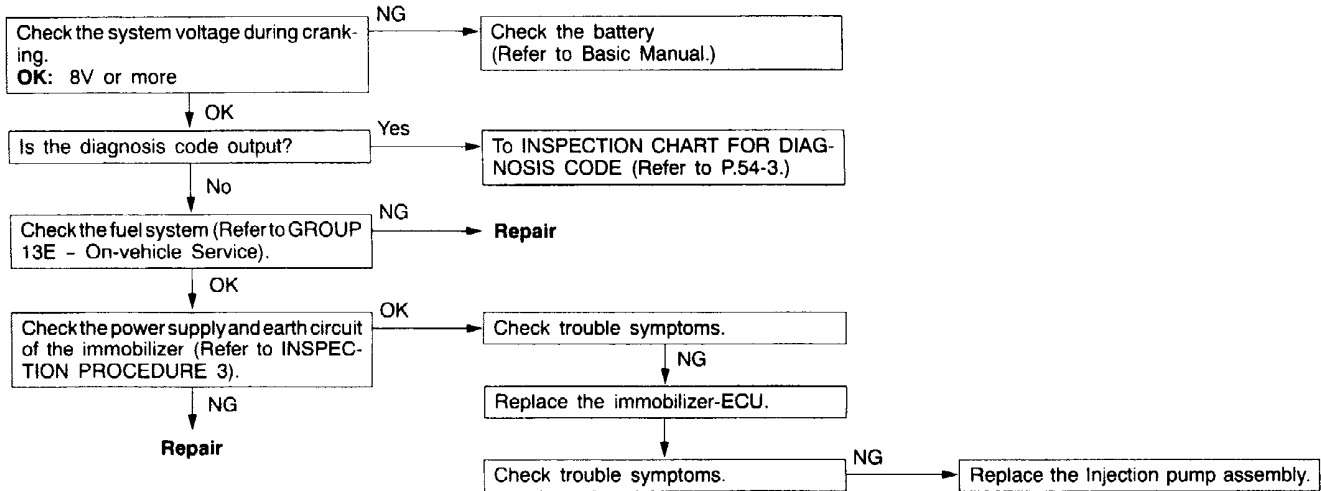

Inspection Procedure 3

Check the power supply and earth circuit of the immobilizer

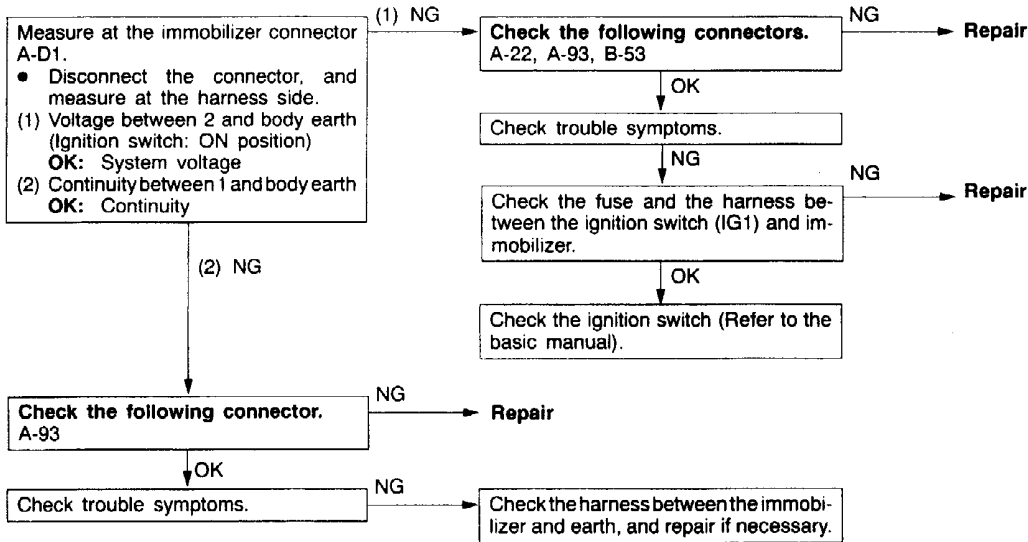

REAR COMBINATION LAMP, REAR LID LAMP

SPECIAL TOOL

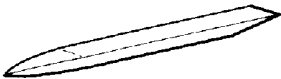
Tool	Number	Name	Use
	MB990784	Ornament remover	Removal of switch garnish

REAR COMBINATION LAMP, REAR LID LAMP

REMOVAL AND INSTALLATION

Caution: SRS
 Before removal of air bag module and clock spring, refer to Basic Manual GROUP 52B – SRS Service Precautions and Air Bag Module and Clock Spring.

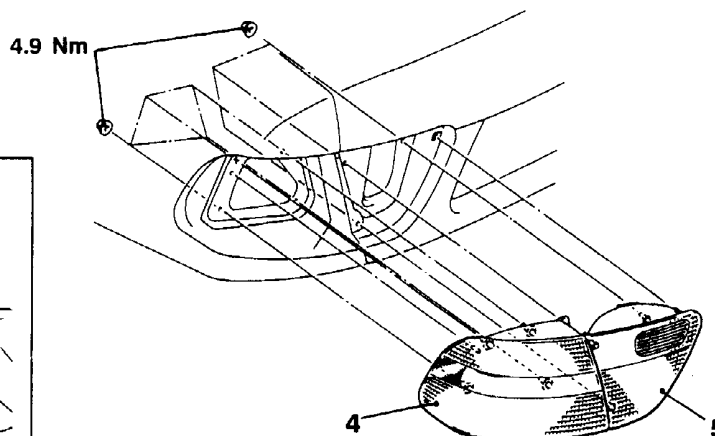
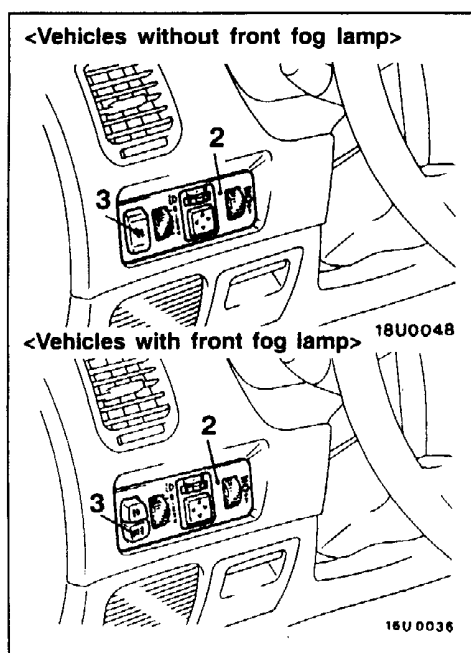

20U0047

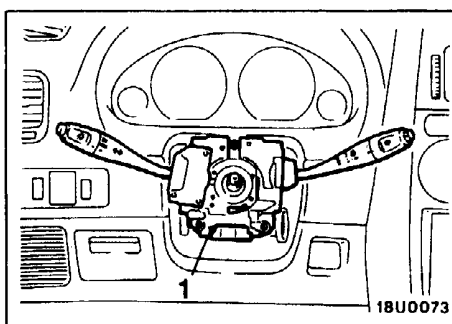

00005107

1. Column switch <Lighting switch and turn-signal lamp switch>

Rear fog lamp switch removal steps

2. Switch garnish
3. Rear fog lamp switch

Rear combination lamp removal

4. Rear combination lamp assembly

Rear lid lamp removal

5. Rear lid lamp assembly

HIGH MOUNTED STOP LAMP

REMOVAL AND INSTALLATION

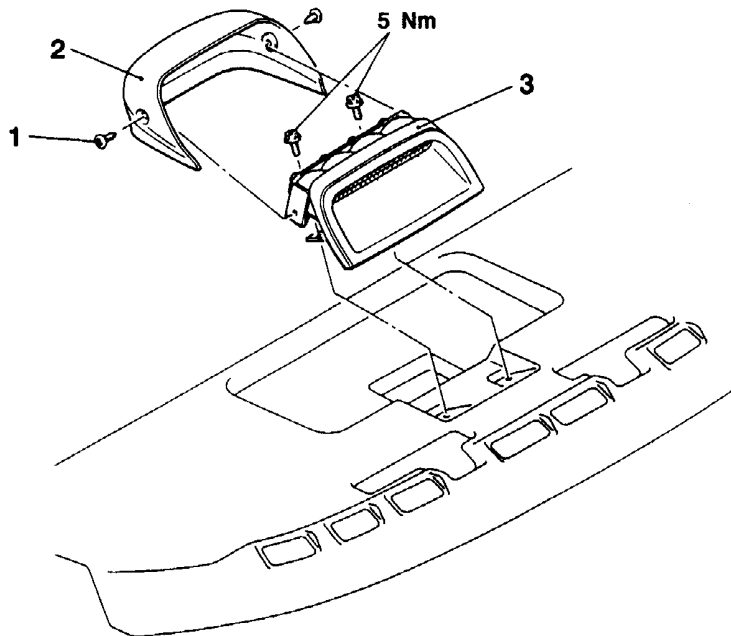

A20U0048

Removal steps

1. Clip
2. High mounted stop lamp cover
3. High mounted stop lamp assembly

NOTE

For the stop lamp on the rear spoiler, refer to GROUP 51 - Aero Parts.

SPEAKER

REMOVAL AND INSTALLATION

Pre-removal and post-installation Operation

- Rear Speaker Garnish Removal and Installation (Refer to GROUP 52A - Trims.)

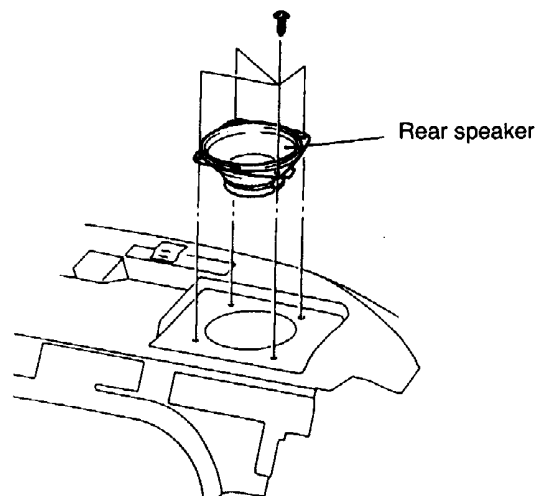

A19U0096