

---

# GENERAL

## CONTENTS

00109000102

<b>HOW TO USE THIS MANUAL</b> .....	<b>2</b>	Models .....	14
Scope of Maintenance, Repair and Servicing Explanations .....	2	Model Code .....	14
Definition of Terms .....	2	Chassis Number .....	15
Indication of Tightening torque .....	2	Engine Model Number .....	16
Model Indications .....	3	<b>MAJOR SPECIFICATIONS</b> .....	<b>17</b>
Explanation of Manual Contents .....	4	<b>PRECAUTIONS BEFORE SERVICE</b> .....	<b>18</b>
<b>HOW TO USE TROUBLESHOOTING/INSPECTION SERVICE POINTS</b> .....	<b>6</b>	<b>SUPPLEMENTAL RESTRAINT SYSTEM (SRS) AND SEAT BELTS WITH PRE-TENSIONER</b> .....	<b>22</b>
Troubleshooting Contents .....	6	<b>SUPPORT LOCATIONS FOR LIFTING AND JACKING</b> .....	<b>26</b>
Diagnosis Function .....	7	Support Positions for a Garage Jack and Axle Stands .....	26
How to Use the Inspection Procedures .....	9	Support Positions for a Single-Post Lift or Double-Post Lift .....	27
Connector Measurement Service Points .....	10	Support Positions and Support Method for an H-Bar Lift .....	28
Connector Inspection .....	11	<b>STANDARD PARTS-TIGHTENING-TORQUE TABLE</b> .....	<b>30</b>
Inspection Service Points for a Blown Fuse ...	12		
Points to Note for Intermittent Malfunctions ...	12		
<b>VEHICLE IDENTIFICATION</b> .....	<b>13</b>		
Vehicle Information Code Plate .....	13		

---

## HOW TO USE THIS MANUAL

00100010081

### SCOPE OF MAINTENANCE, REPAIR AND SERVICING EXPLANATIONS

This manual provides explanations, etc. concerning procedures for the inspection, maintenance, repair and servicing of the subject model. Note, however, that for engine and transmission-related component parts, this manual covers only on-vehicle inspections, adjustments, and the removal and installation procedures for major components.

For detailed information concerning the inspection, checking, adjustment, disassembly and reassembly of the engine, transmission and major components after they have been removed from the vehicle, please refer to separate manuals covering the engine and the transmission.

### ON-VEHICLE SERVICE

“On-vehicle Service” is procedures for performing inspections and adjustments of particularly important locations with regard to the construction and for maintenance and servicing, but other inspection (for looseness, play, cracking, damage, etc.) must also be performed.

### INSPECTION

Under this title are presented inspection and checking procedures to be performed by using special tools and measuring instruments and by feeling, but, for actual maintenance and servicing procedures, visual inspections should always be performed as well.

### DEFINITION OF TERMS

#### STANDARD VALUE

Indicates the value used as the standard for judging the quality of a part or assembly on inspection or the value to which the part or assembly is corrected and adjusted. It is given by tolerance.

#### LIMIT

Shows the standard for judging the quality of a part or assembly on inspection and means the maximum or minimum value within which the part or assembly must be kept functionally or in strength. It is a value established outside the range of standard value.

#### REFERENCE VALUE

Indicates the adjustment value prior to starting the work (presented in order to facilitate assembly and adjustment procedures, and so they can be completed in a shorter time).

#### CAUTION

Indicates the presentation of information particularly vital to the worker during the performance of maintenance and servicing procedures in order to avoid the possibility of injury to the worker, or damage to component parts, or a reduction of component or vehicle function or performance, etc.

#### INDICATION OF TIGHTENING TORQUE

The tightening torque shown in this manual is a basic value with a tolerance of +10% except the following cases when the upper and lower limits of tightening torque are given.

- (1) The tolerance of the basic value is within +10%.
- (2) Special bolts or the like are in use.
- (3) Special tightening methods are used.

**MODEL INDICATIONS**

The following abbreviations are used in this manual for classification of model types.

M/T:	Indicates the manual transmission, or models equipped with the manual transmission.
A/T:	Indicates the automatic transmission, or models equipped with the automatic transmission.
SOHC:	Indicates an engine with the single overhead camshaft, or a model equipped with such an engine.
DOHC:	Indicates an engine with the double overhead camshaft, or a model equipped with such an engine.
MPI:	Indicates the multi-point injection, or engines equipped with the multi-point injection.
2WD:	Indicates the front wheel-drive vehicles.

## EXPLANATION OF MANUAL CONTENTS

Indicates procedures to be performed before the work in that section is started, and procedures to be performed after the work in that section is finished.

**Component Diagram**

A diagram of the component parts is provided near the front of each section in order to give a reader a better understanding of the installed condition of component parts.

Indicates (by symbols) where lubrication is necessary.

**Maintenance and Servicing Procedures**

The numbers provided within the diagram indicate the sequence for maintenance and servicing procedures.

- **Removal steps:**  
The part designation number corresponds to the number in the illustration to indicate removal steps.
- **Disassembly steps:**  
The part designation number corresponds to the number in the illustration to indicate disassembly steps.

- **Installation steps:**  
Specified in case installation is impossible in reverse order of removal steps. Omitted if installation is possible in reverse order of removal steps.
- **Reassembly steps:**  
Specified in case reassembly is impossible in reverse order of disassembly steps. Omitted if reassembly is possible in reverse order of disassembly steps.





**Classifications of Major Maintenance/Service Points**

When there are major points relative to maintenance and servicing procedures (such as essential maintenance and service points, maintenance and service standard values, information regarding the use of special tools, etc.), these are arranged together as major maintenance and service points and explained in detail.

- ◀A▶ : Indicates that there are essential points for removal or disassembly.
- ▶A◀ : Indicates that there are essential points for installation or reassembly.

**Symbols for Lubrication, Sealants and Adhesives**

Information concerning the locations for lubrication and for application of sealants and adhesives is provided, by using symbols, in the diagram of component parts or on the page following the component parts page, and explained.

-  : Grease  
(multipurpose grease unless there is a brand or type specified)
-  : Sealant or adhesive
-  : Brake fluid or automatic transmission fluid
-  : Engine oil, gear oil or air conditioner compressor oil
-  : Adhesive tape or butyl rubber tape

Indicates the group title.

Indicates the section title.

Indicates the group number.

Indicates the page number.

STEERING – Power Steering Oil Pump 37A-29

POWER STEERING GEAR BOX  
REMOVAL AND INSTALLATION

120000039

**Pre-removal Operation**  
 (1) Power Steering Fluid Draining (Refer to P. 37A-10.)  
 (2) Air Cleaner Assembly Removal  
 (3) Under Cover Removal (Refer to GROUP 42 Under Cover.)

<2WD>

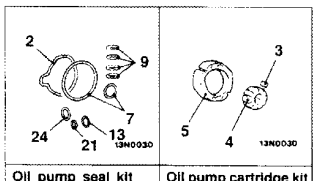
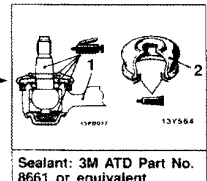
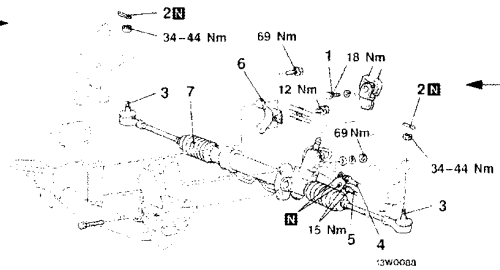

- Removal steps**
1. Lower shaft assembly and gear box connecting bolt
  2. Split pin
  3. Connection for tie-rod end and knuckle
  4. Connection for return tube

5. Connection for pressure tube
6. Clamp
7. Gear box assembly

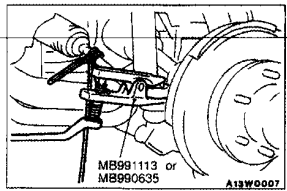

REMOVAL SERVICE POINTS

◀A▶ TIE-ROD END DISCONNECTION

- Caution**
1. Using the special tool, loosen the tie rod end mounting nut. Only loosen the nut; do not remove it from the ball joint.
  2. Support the special tool with a cord, etc. to prevent it from coming off.

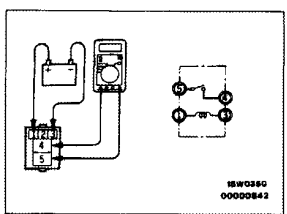

HEADLAMP RELAY CONTINUITY INSPECTION

Battery voltage	Terminal No.			
	1	3	4	5
Power is not supplied	○—○	○—○	○—○	○—○
Power is supplied	⊕—○	○—○	○—○	○—○

35A-26 BASIC BRAKE SYSTEM – Master Cylinder and Brake Booster

Lubrication and sealing points

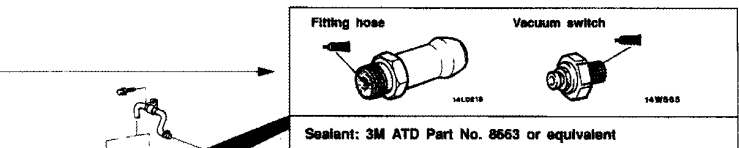

Denotes non-reusable part.

Denotes tightening torque. For bolts and nuts which do not have a tightening torque listed, refer to the "Standard Parts-tightening-torque Table".

Repair kit or set parts are shown. (Only very frequently used parts are shown.)

Operating procedures, cautions, etc. on removal, installation, disassembly and reassembly are described.

○—○ indicates that there is a continuity between the terminals.  
 ⊕—○ indicates terminals to which battery voltage is applied.

The title of the page (following the page on which the diagram of component parts is presented) indicating the locations of lubrication and sealing procedures.

# HOW TO USE TROUBLESHOOTING/INSPECTION SERVICE POINTS

00100020046

Troubleshooting of electronic control systems for which the MUT-II can be used follows the basic outline described below. Furthermore, even in systems for which the MUT-II cannot be used, part of these systems still follow this outline.

## TROUBLESHOOTING CONTENTS

### 1. STANDARD FLOW OF DIAGNOSIS TROUBLESHOOTING

The troubleshooting sections follow the basic diagnosis flow which is given below. If the diagnosis flow is different from that given below, or if additional explanation is required, the details of such differences or additions will also be listed.

#### Diagnosis method

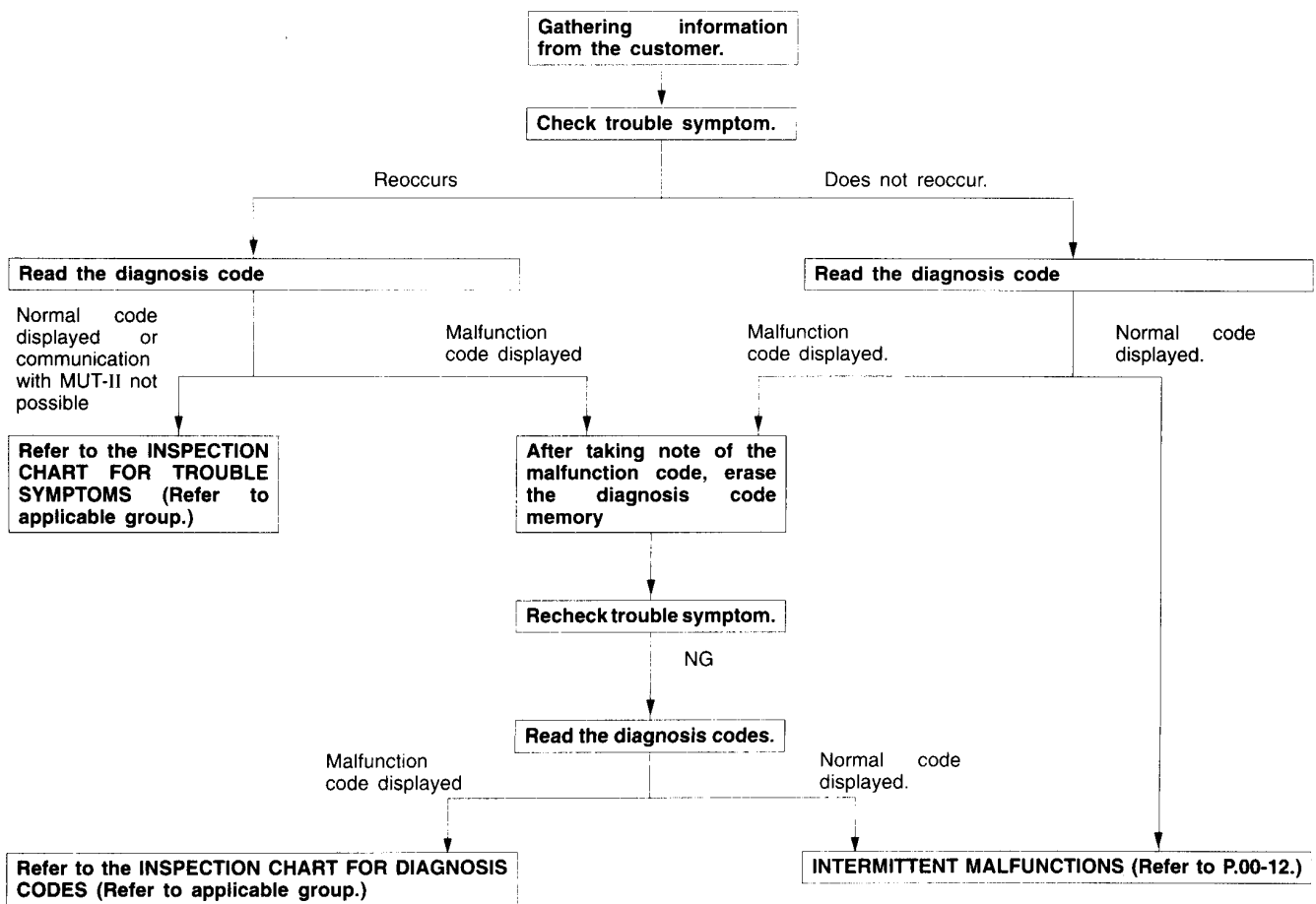

### 2. SYSTEM OPERATION AND SYMPTOM VERIFICATION TESTS

If verification of the trouble symptoms is difficult, procedures for checking operation and verifying trouble symptoms are shown.

### 3. DIAGNOSIS FUNCTION

Details which are different from those in the “Diagnosis Function” section on the next page are listed.

**4. INSPECTION CHART FOR DIAGNOSIS CODES****5. INSPECTION PROCEDURE FOR DIAGNOSIS CODES**

Indicates the inspection procedures corresponding to each diagnosis code. (Refer to the next page for how to read the inspection procedures.)

**6. INSPECTION CHART FOR TROUBLE SYMPTOMS**

If there are trouble symptoms even though the results of inspection using the MUT-II show that all diagnosis codes are normal, inspection procedures for each trouble symptom will be found by means of this chart.

**7. INSPECTION PROCEDURE FOR DIAGNOSIS SYMPTOM**

Indicates the inspection procedures corresponding to each trouble symptoms classified in the Inspection Chart for Trouble Symptoms. (Refer to the next page for how to read the inspection procedures.)

**8. SERVICE DATA REFERENCE TABLE**

Inspection items and normal judgement values have been provided in this chart as reference information.

**9. CHECK AT ECU TERMINALS**

Terminal numbers for the ECU connectors, inspection items and standard values have been provided in this chart as reference information.

**10. INSPECTION PROCEDURES USING AN OSCILLOSCOPE**

When there are inspection procedures using an oscilloscope, these are listed here.

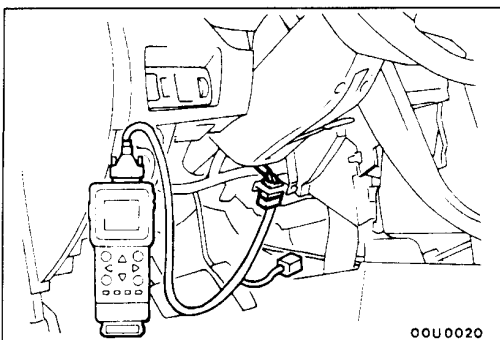
**DIAGNOSIS FUNCTION****METHOD OF READING DIAGNOSIS CODES****When using the MUT-II**

Connect the MUT-II to the diagnosis connector and take a reading of the diagnosis codes.

**Caution**

Connection and disconnection of the MUT-II should always be carried out with the ignition switch in the OFF position.

## **00-8 GENERAL – How to Use Troubleshooting/Inspection Service Points**

---

### **2. METHOD OF ERASING DIAGNOSIS CODES**

#### **When using the MUT-II**

- Connect the MUT-II to the diagnosis connector and erase the diagnosis code.

#### **Caution**

- **Connection and disconnection of the MUT-II should always be carried out with the ignition switch in the OFF position.**

#### **When not using the MUT-II**

- (1) Turn the ignition switch to OFF.
- (2) After disconnecting the battery cable from the battery (-) terminal for 10 seconds or more, reconnect the cable.
- (3) After the engine has warmed up, run it at idle for about 15 minutes.



**HOW TO USE THE INSPECTION PROCEDURES**

The causes of a high frequency of problems occurring in electronic circuitry are generally the connectors, components, the ECU and the harnesses between connectors, in that order. These inspection procedures follow this order, and they first try to discover a problem with a connector or a defective component.

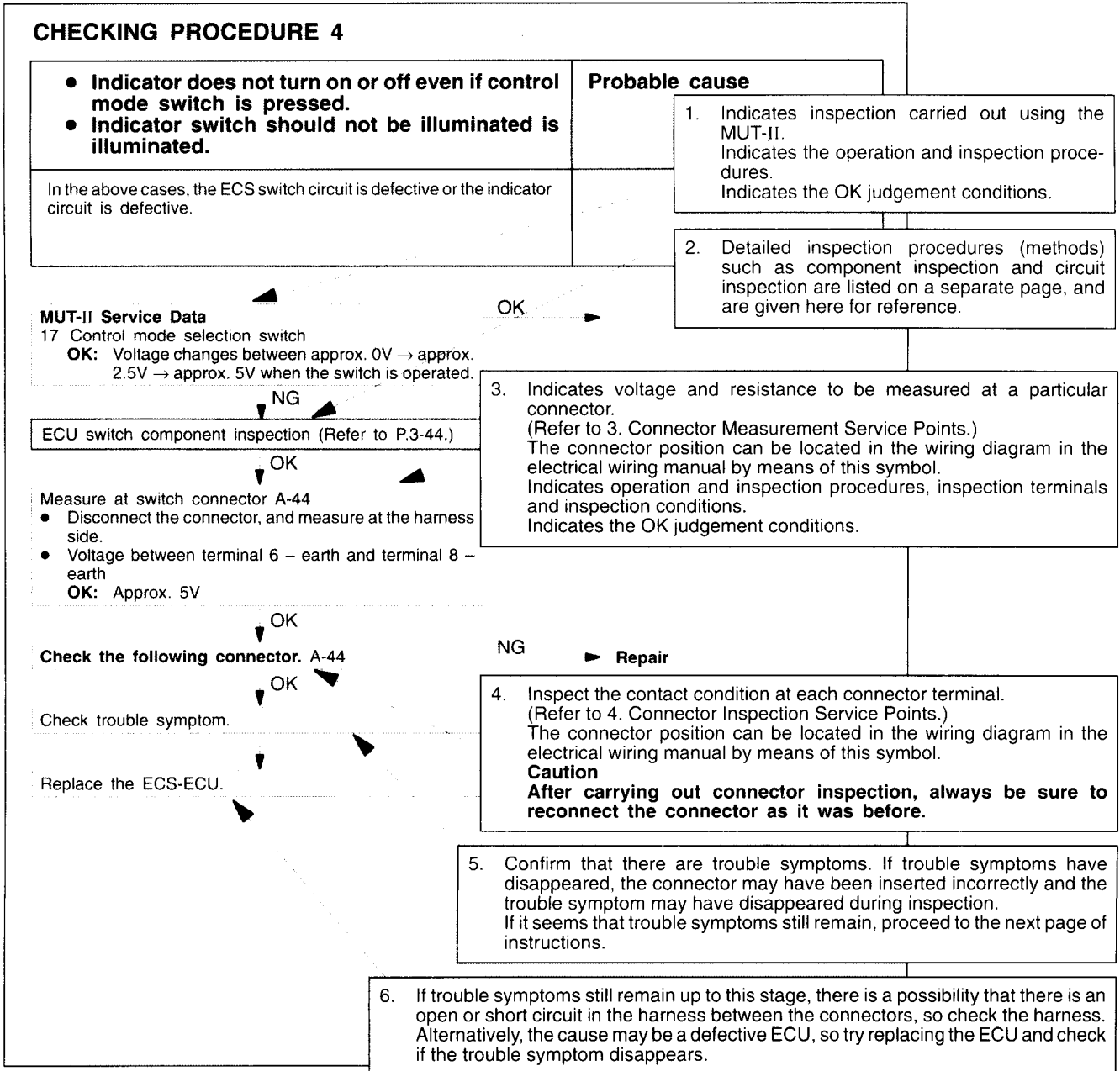

**HARNESS INSPECTION**

Check for an open or short circuit in the harness between the terminals which were defective according to the connector measurements. Carry out this inspection while referring to the electrical wiring manual. Here, “Check harness between power supply and terminal xx” also includes checking for blown fuses. For inspection service points when there is a blown fuse, refer to “Inspection Service Points for a Blown Fuse.”

**MEASURES TO TAKE AFTER REPLACING THE ECU**

If the trouble symptoms have not disappeared even after replacing the ECU, repeat the inspection procedure from the beginning.

**CONNECTOR MEASUREMENT SERVICE POINTS**

Turn the ignition switch to OFF when connecting/disconnecting the connectors, and turn the ignition switch to ON when measuring if there are no instructions to be contrary.

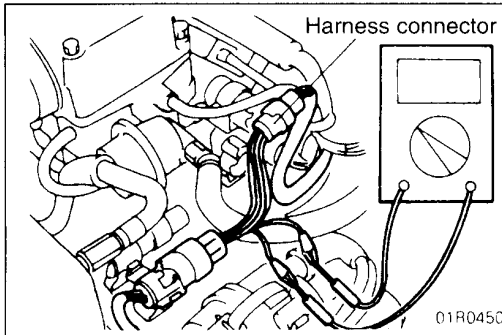

**IF INSPECTING WITH THE CONNECTOR CONNECTED (WITH CIRCUIT IN A CONDITION OF CONTINUITY)**

**Waterproof Connectors**

Be sure to use the special tool (harness connector). Never insert a test bar from the harness side, because to do so will reduce the waterproof performance and result in corrosion.

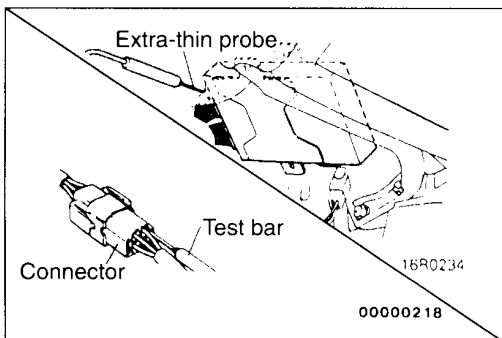

**Ordinary (non-waterproof) Connectors**

Check by inserting the test bar from the harness side. Note that if the connector (control unit, etc.) is too small to permit insertion of the test bar, it should not be forced; use a special tool (the extra-thin probe in the harness set for checking for this purpose).

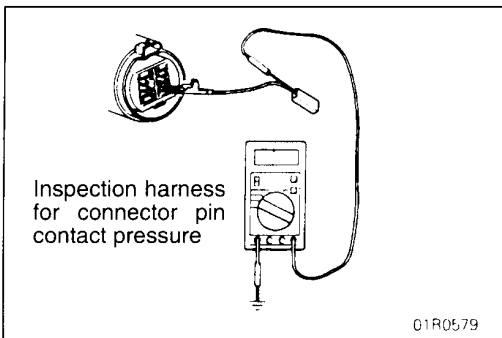

**IF INSPECTING WITH THE CONNECTOR DISCONNECTED**

**<When Inspecting a Female Pin>**

Use the special tool (inspection harness for connector pin contact pressure in the harness set for inspection). The inspection harness for connector pin contact pressure should be used. The test bar should never be forcibly inserted, as it may cause a defective contact.

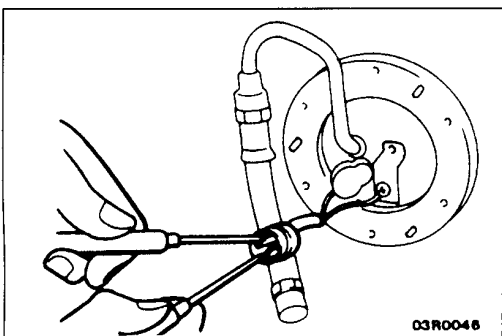

**<When Inspecting a Male Pin>**

Touch the pin directly with the test bar.

**Caution**

**At this time, be careful not to short the connector pins with the test bars. To do so may damage the circuits inside the ECU.**

Connector disconnected or improperly connected

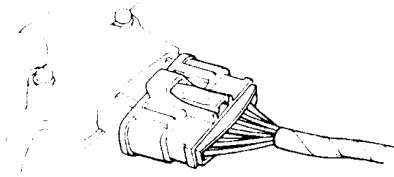

16S0256

Defective connector contact

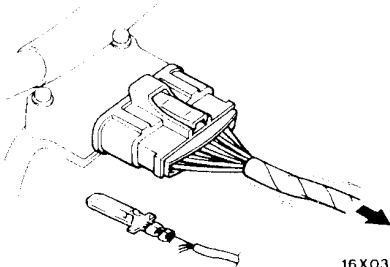

Harness wire breakage at terminal section

16X0369

Low contact pressure

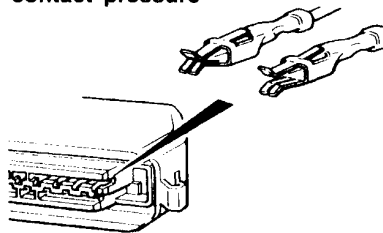

16S0254  
00000219

## CONNECTOR INSPECTION

### VISUAL INSPECTION

- Connector is disconnected or improperly connected
- Connector pins are pulled out
- Due to harness tension at terminal section
- Low contact pressure between male and female terminals
- Low connection pressure due to rusted terminals or foreign matter lodged in terminals

### CONNECTOR PIN INSPECTION

If the connector pin stopper is damaged, the terminal connections (male and female pins) will not be perfect even if the connector body is connected, and the pins may pull out of the reverse side of the connector. Therefore, gently pull the harnesses one by one to make sure that no pins pull out of the connector.

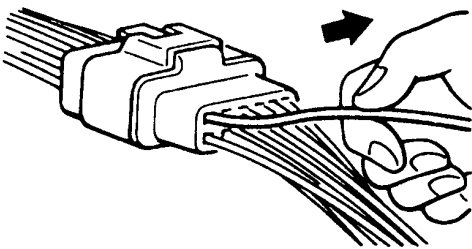

16R1317

### CONNECTOR ENGAGEMENT INSPECTION

Use the special tool (connector pin connection pressure inspection harness of the inspection harness set) to inspect the engagement of the male pins and female pins. (Pin drawing force : 1 N or more)

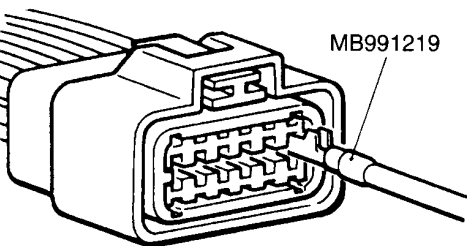

MB991219

16R1318

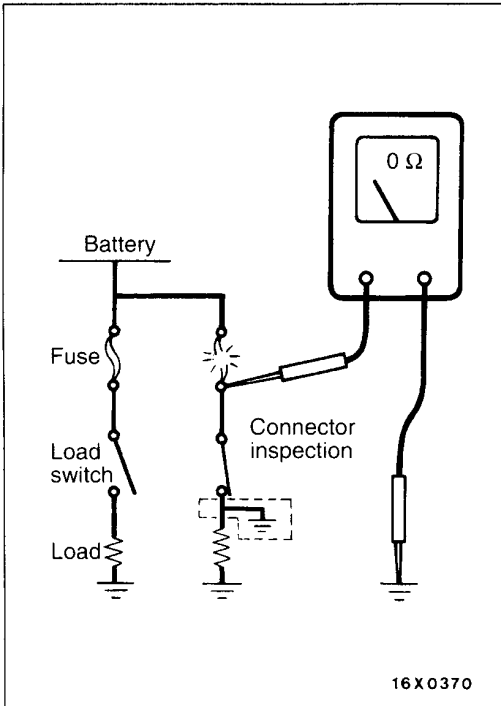

### INSPECTION SERVICE POINTS FOR A BLOWN FUSE

Remove the fuse and measure the resistance between the load side of the fuse and the earth. Set the switches of all circuits which are connected to this fuse to a condition of continuity. If the resistance is almost  $0 \Omega$  at this time, there is a short somewhere between these switches and the load. If the resistance is not  $0 \Omega$ , there is no short at the present time, but a momentary short has probably caused the fuse to blow.

The main causes of a short circuit are the following.

- Harness being clamped by the vehicle body
- Damage to the outer casing of the harness due to wear or heat
- Water getting into the connector or circuitry
- Human error (mistakenly shorting a circuit, etc.)

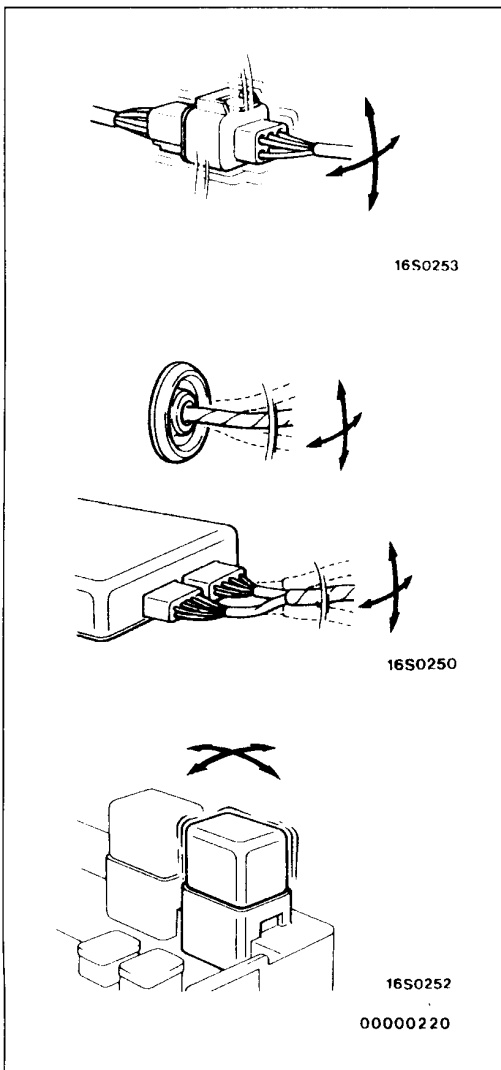

### POINTS TO NOTE FOR INTERMITTENT MALFUNCTIONS

Intermittent malfunctions often occur under certain conditions, and if these conditions can be ascertained, determining the cause becomes simple. In order to ascertain the conditions under which an intermittent malfunction occurs, first ask the customer for details about the driving conditions, weather conditions, frequency of occurrence and trouble symptoms, and then try to recreate the trouble symptoms. Next, ascertain whether the reason why the trouble symptom occurred under these conditions is due to vibration, temperature or some other factor. If vibration is thought to be the cause, carry out the following checks with the connectors and components to confirm whether the trouble symptom occurs.

The objects to be checked are connectors and components which are indicated by inspection procedures or given as probable causes (which generates diagnosis codes or trouble symptoms.)

- Gently shake the connector up, down and to the left and right.
- Gently shake the wiring harness up, down and to the left and right.
- Gently rock each sensor and relay, etc. by hand.
- Gently shake the wiring harness at suspensions and other moving parts.

#### NOTE

If determining the cause is difficult, the flight recorder function of the MUT-II can also be used.

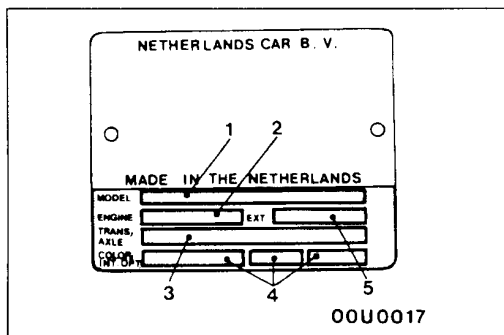
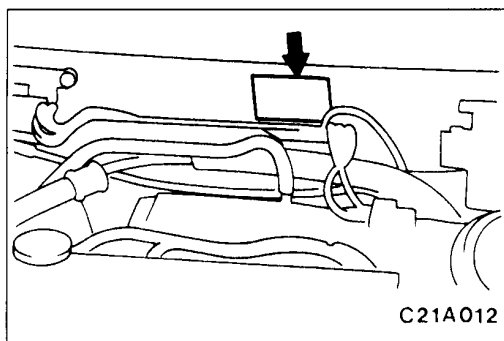

## VEHICLE IDENTIFICATION

00100540023

### VEHICLE INFORMATION CODE PLATE

#### LOCATION

Vehicle information code plate is riveted on the toeboard inside the engine compartment.

#### CODE PLATE DESCRIPTION

The plate shows model code, engine model, transmission model, and body colour code.

No.	Item	Contents	
1	MODEL	DA2A	DA2A: Vehicle model
		LNJEL6	LNJEL6: Model series
2	ENGINE	4G93	Engine model
3	TRANS AXLE	F5MR2	Transmission code
4	COLOR INT OPT	B60 41H 03V	B60: Body colour code
			41H: Interior code
			03V: Equipment code
5	EXT	B60B	Exterior code

For monotone colour vehicles, the body colour code shall be indicated. For two-tone or three-way two-tone colour vehicles, each colour code only shall be indicated in series.

## MODELS

00100030100

Model code	Engine model	Transmission model	Fuel supply system
DA1A	LNDEL6/R6	4G92-SOHC (1,597mℓ)	MPI
	LRDEL6/R6		
	LNJEL6/R6		
	LRJEL6/R6		
DA2A	LNJEL6/R6	4G93-SOHC (1,834 mℓ)	MPI
	LRJEL6/R6		
	LNPEL6/R6		
	LRPEL6/R6		
	LNGML6	4G93-DOHC (1,834 mℓ)	

<b>D</b>	<b>A</b>	<b>1</b>	<b>A</b>	<b>L</b>	<b>N</b>	<b>J</b>	<b>E</b>	<b>L</b>	<b>6</b>
1	2	3	4	5	6	7	8	9	

00U0114

## MODEL CODE

00100040035

No.	Items	Contents
1	Development	DA: MITSUBISHI CARISMA
2	Engine type	1: 1,597 mℓ petrol engine
		2: 1,834 mℓ petrol engine
3	Sort	A: Passenger car
4	Body style	L: 5-door hatchback
5	Transmission type	N: 5-speed manual transmission
		R: 4-speed automatic transmission
6	Trim level	D: GL
		J: GLX
		P: GLS
		G: MSX
7	Specified engine feature	E: MPI-SOHC
		M: MPI-DOHC
8	Steering wheel location	L: Left hand
		R: Right hand
9	Destination	6: For Europe

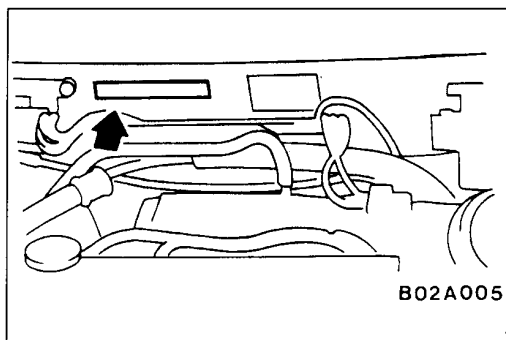

**CHASSIS NUMBER**

00100560029

The chassis number is stamped on the toeboard inside the engine compartment.

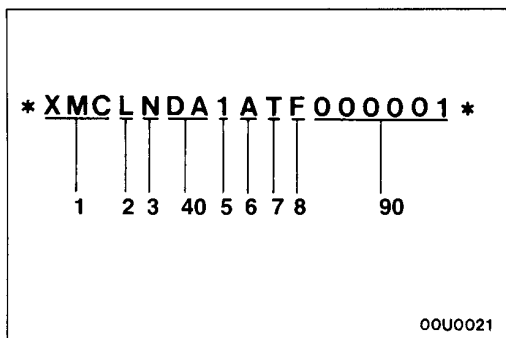

No.	Items		Contents
1	Steering wheel location	XMC	Left hand drive
		XMD	Right hand drive
2	Body style	L	5-door hatchback
3	Transmission type	N	5-speed manual transmission
		R	4-speed automatic transmission
4	Vehicle line	DA	CARISMA
5	Development order	1	1,597 mℓ petrol engine
		2	1,834 mℓ petrol engine
6	Sort	A	Passenger car
7	Model year	T	1996
8	Factory code	F	Netherlands Car B.V.
9	Serial number	–	–

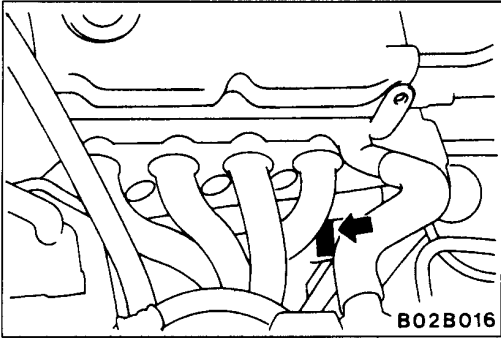

**ENGINE MODEL NUMBER**

00100570022

1. The engine model number is stamped at the cylinder block as shown in the following.

Engine model	Engine displacement
4G92	1,597
4G93	1,834

2. The engine serial number is stamped near the engine model number.

Engine serial number	AA0201 to YY9999
----------------------	------------------



MAJOR SPECIFICATIONS

00100080044

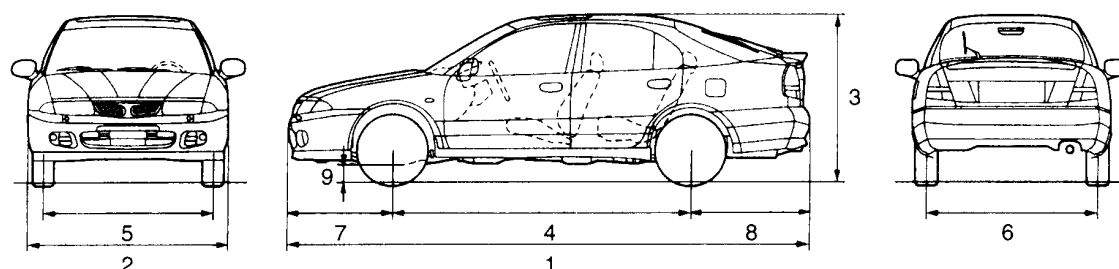

00U0005

Items		DA1A LNDE L6, LNDE R6	DA1A LRDE L6, LRDE R6	DA1A LNJE L6, LNJE R6	DA1A LRJE L6, LRJE R6	DA2A LNJE L6, LNJE R6	DA2A LRJE L6, LRJE R6	DA2A LNPE L6, LNPE R6	DA2A LRPE L6, LRPE R6	DA2A LNG ML6
Vehicle dimensions mm	Overall length	1	4,435	4,435	4,435	4,435	4,435	4,435	4,435	4,435
	Overall width	2	1,695	1,695	1,695	1,695	1,695	1,695	1,695	1,695
	Overall height (unladen)	3	1,405	1,405	1,405	1,405	1,405	1,405	1,405	1,405
	Wheelbase (laden)	4	2,550	2,550	2,550	2,550	2,550	2,550	2,550	2,550
	Track-front	5	1,455	1,455	1,455	1,455	1,455	1,455	1,455	1,455
	Track-rear	6	1,475	1,475	1,475	1,475	1,475	1,475	1,475	1,475
	Overhang-front	7	880	880	880	880	880	880	880	880
	Overhang-rear	8	1,005	1,005	1,005	1,005	1,005	1,005	1,005	1,005
	Ground clearance (unladen)	9	155	150	155	150	155	150	155	150
Vehicle weight kg	Kerb weight		1,105	1,135	1,110	1,140	1,130	1,160	1,135	1,165
	Max. gross vehicle weight rating		1,630	1,660	1,630	1,660	1,660	1,690	1,660	1,690
	Max. axle weight rating-front		900	900	900	900	900	900	900	900
	Max. axle weight rating-rear		865	865	865	865	875	875	875	875
Seating capacity		5								
Engine	Model No.	4G92				4G93				
	Total displacement ml	1,597				1,834				
Transmission	Model No.	F5MR 1	F4A41	F5MR 1	F4A41	F5MR 2	F4A42	F5MR 2	F4A42	F5MR 2
	Type	5 speed-manual	4 speed-automatic	5 speed-manual	4 speed-automatic	5 speed-manual	4 speed-automatic	5 speed-manual	4 speed-automatic	5 speed-manual
Fuel system	Fuel supply system	Electronic control multipoint fuel injection								

**PRECAUTIONS BEFORE SERVICE**

00100050045

**SUPPLEMENTAL RESTRAINT SYSTEM (SRS), SEAT BELT WITH PRE-TENSIONER**

1. Items to follow when servicing SRS
  - (1) Be sure to read GROUP 52B – Supplemental Restraint System (SRS).  
For safe operations, please follow the directions and heed all warnings.
  - (2) Always use the designated special tools and test equipment.
  - (3) Wait at least 60 seconds after disconnecting the battery cable before doing any further work.  
The SRS system is designed to retain enough voltage to deploy the air bag even after the battery has been disconnected. Serious injury may result from unintended air bag deployment if work is done on the SRS system immediately after the battery cable is disconnected.
  - (4) Never attempt to disassemble or repair the SRS components, (SRS air bag control unit, air bag module and clock spring) and seat belt with pre-tensioner. If faulty, replace it.
  - (5) Warning labels must be heeded when servicing or handling SRS components and seat belt with pre-tensioner. Warning labels are located in the following locations.
    - Sun visor
    - Glove box
    - SRS air bag control unit
    - Steering wheel
    - Steering gear and linkage
    - Air bag module
    - Clock spring
    - Seat belt with pre-tensioner
  - (6) Store components removed from the SRS and seat belt with pre-tensioner in a clean and dry place.  
The air bag module and seat belt with pre-tensioner should be stored on a flat surface and placed so that the pad surface is facing upward.  
Do not place anything on top of it.
  - (7) Be sure to deploy the air bag and seat belt with pre-tensioner before disposing of the air bag module and seat belt with pre-tensioner or disposing of a vehicle equipped with an air bag and seat belt with pre-tensioner. (Refer to GROUP 52B – Air Bag Module Disposal Procedures.)
  - (8) Whenever you finish servicing the SRS and seat belt with pre-tensioner, check the SRS warning lamp operation to make sure that the system functions properly.
2. Observe the following when carrying out operations on places where SRS components and seat belt with pre-tensioner are installed, including operations not directly related to the SRS air bag and seat belt with pre-tensioner.
  - (1) When removing or installing parts do not allow any impact or shock to the SRS components and seat belt with pre-tensioner.
  - (2) SRS components and seat belt with pre-tensioner should not be subjected to heat, so remove the SRS components and seat belt with pre-tensioner before drying or baking the vehicle after painting.
    - SRS air bag control unit, air bag module, clock spring: 93°C or more
    - Seat belt with pre-tensioner 90°C or moreAfter re-installing them, check the SRS warning lamp operation to make sure that the system functions properly.

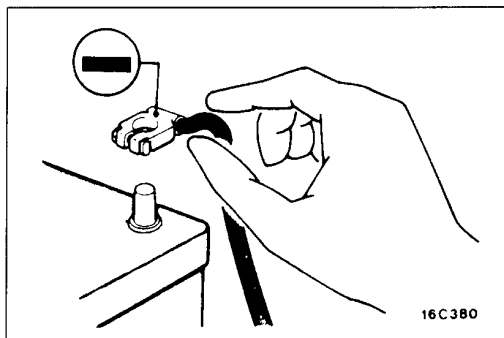

### SERVICING THE ELECTRICAL SYSTEM

Before replacing a component related to the electrical system and before undertaking any repair procedures involving the electrical system, be sure to first disconnect the negative (-) cable from the battery in order to avoid damage caused by short-circuiting.

#### Caution

**Before connecting or disconnecting the negative (-) cable, be sure to turn off the ignition switch and the lighting switch.**

**(If this is not done, there is the possibility of semiconductor parts being damaged.)**

### APPLICATION OF ANTI-CORROSION AGENTS AND UNDERCOATS

If oil or grease gets onto the oxygen sensor, it will cause a drop in the performance of the sensor.

Cover the oxygen sensor with a protective cover when applying anti-corrosion agents and undercoats.

### PRE-INSPECTION CONDITION

“Pre-inspection condition” refers to the condition that the vehicle must be in before proper engine inspection can be carried out. If you see the words “Set the vehicle to the pre-inspection condition.” in this manual, it means to set the vehicle to the following condition.

- Engine coolant temperature: 80–90°C
- Lamps, electric cooling fan and all accessories: OFF
- M/T: Neutral
- A/T: P range

### VEHICLE WASHING

If high-pressure car-washing equipment or steam car-washing equipment is used to wash the vehicle, be sure to note the following information in order to avoid damage to plastic components, etc.

- Spray nozzle distance: 300 mm or more
- Spray pressure: 4 MPa or less
- Spray temperature: 82°C or less
- Time of concentrated spray to one point: within 30 sec.

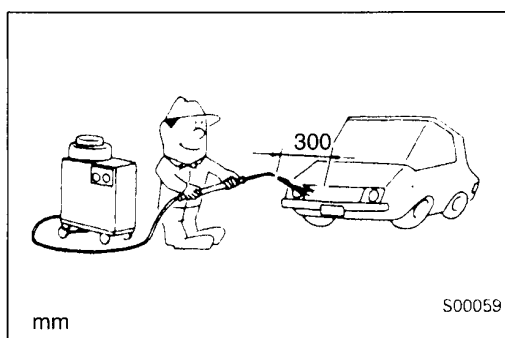

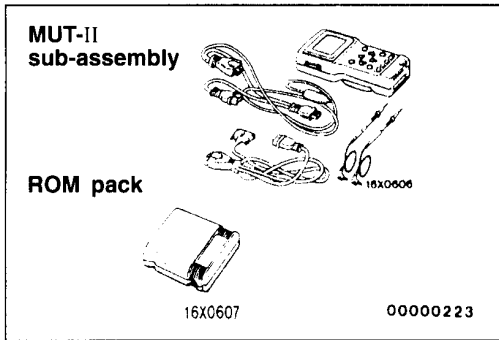
**MUT-II**

Refer to the MUT-II INSTRUCTION MANUAL for instructions on handling the MUT-II.

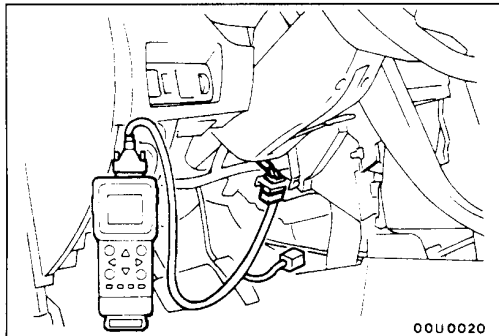

Connect the MUT-II to the diagnosis connector as shown in the illustration.

**Caution**

**Connection and disconnection of the MUT-II should always be made with the ignition switch in the OFF position.**

**IN ORDER TO PREVENT VEHICLES FROM FIRE**

“Improper installation of electrical or fuel related parts could cause a fire. In order to retain the high quality and safety of the vehicle, it is important that any accessories that may be fitted or modifications/repairs that may be carried out which involve the electrical or fuel systems, **MUST** be carried out in accordance with MMC’s information/Instructions”.

**ENGINE OILS****Health Warning**

Prolonged and repeated contact with mineral oil will result in the removal of natural fats from the skin, leading to dryness, irritation and dermatitis. In addition, used engine oil contains potentially harmful contaminants which may cause skin cancer. Adequate means of skin protection and washing facilities must be provided.

**Recommended Precautions**

The most effective precaution is to adapt working practices which prevent, as far as practicable, the risk of skin contact with mineral oils, for example by using enclosed systems for handling used engine oil and by degreasing components, where practicable, before handling them.

Other precautions:

- Avoid prolonged and repeated contact with oils, particularly used engine oils.
- Wear protective clothing, including impervious gloves where practicable.
- Avoid contaminating clothes, particularly underpants, with oil.
- Do not put oily rags in pockets, the use of overalls without pockets will avoid this.
- Do not wear heavily soiled clothing and oil-impregnated foot-wear. Overalls must be cleaned regularly and kept separately from personal clothing.
- Where there is a risk of eye contact, eye protection should be worn, for example, chemical goggles or face shields; in addition an eye wash facility should be provided.
- Obtain First Aid treatment immediately for open cuts and wounds.
- Wash regularly with soap and water to ensure all oil is removed, especially before meals (skin cleansers and nail brushes will help). After cleaning, the application of preparations containing lanolin to replace the natural skin oils is advised.
- Do not use petrol, kerosine, diesel fuel, gas oil, thinners or solvents for cleaning skin.
- Use barrier creams, applying them before each work period, to help the removal of oil from the skin after work.
- If skin disorders develop, obtain medical advice without delay.

## **SUPPLEMENTAL RESTRAINT SYSTEM (SRS) AND SEAT BELT WITH PRE-TENSIONER**

00100590028

To improve safety, the SRS and seat belt with pre-tensioner are available as optional parts. These systems enhance a collision safety by restraining

the front passengers in case of an accident. The SRS works with the pre-tensioner simultaneously when a collision is detected.

### **SUPPLEMENTAL RESTRAINT SYSTEM (SRS)**

The SRS is designed to supplement the front seat belts. It eliminates or reduces an injury to the front

passengers by deploying two air bags in case of a head-on collision.

### **SEAT BELT WITH PRE-TENSIONER**

The seat belt with pre-tensioner work simultaneously with the SRS. The pre-tensioner takes up seat belt slack immediately at a collision,

by that restraining the front passengers sooner than the SRS. This prevents the passengers from moving forwards.

### **CAUTION**

1. Even if there is no passenger, the air bag and pre-tensioner will work by detecting a bigger head-on collision than a specific value.
2. The specific value is an equivalent impact when a vehicle collides against a concrete (fixed) wall at approx. 25 km/h or more.
3. The SRS and pre-tensioner may not work under the following conditions:
  - A head-on collision is smaller than the specific value.
  - A vehicle collides on its side or rear end.
  - A vehicle rolls over or upsets.

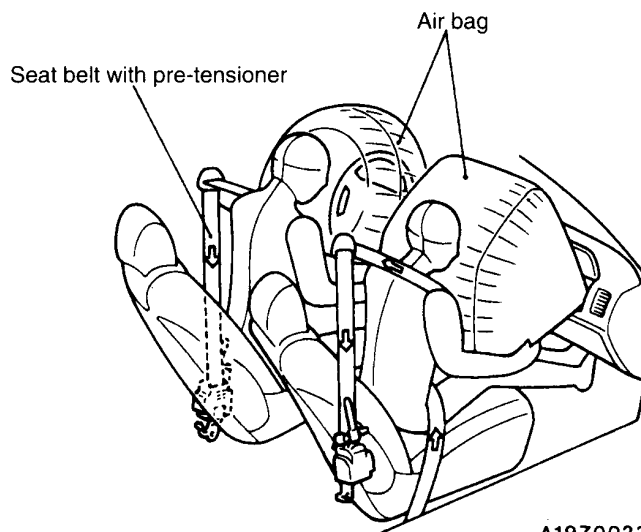

A19Z0023

The SRS and seat belt tightening systems consist of two air bag modules, SRS air bag control unit (SRS-ECU), SRS warning lamp and clock spring and seat belt pre-tensioner. One air bag is located in the centre of the steering wheel and another above the glove box. Each air bag has the folded air bag and an inflator unit. The control unit under the floor console monitors the system and a safing G sensor and an analogue G sensor. The warning lamp on the instrument panel indicates the operational status of the SRS. The clock spring is installed in the steering column.

The SRS-ECU has the following functions:

- Back up function (charging condenser for power supply) in case of a power failure when the SRS air bag is deployed (in a collision).
- Voltage raising function (DC – DC converter circuit) in case of a drop in the battery voltage
- Self-diagnosis function to improve safety and reliability

**CONSTRUCTION DIAGRAM**

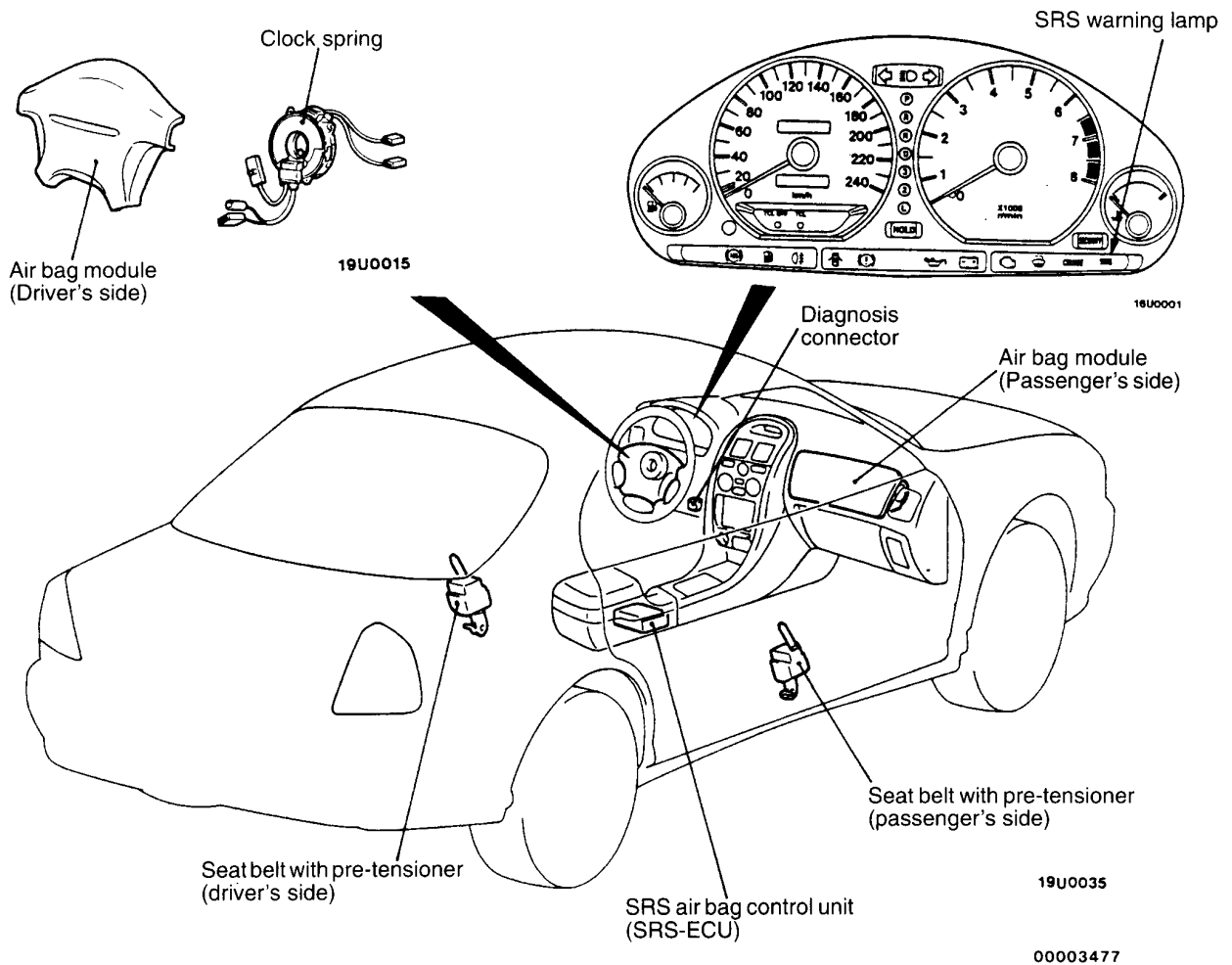

## SRS SERVICE PRECAUTIONS

00100600028

1. In order to avoid injury to yourself or others from accidental deployment of the air bag or accidental operation of the seat belt pretensioner during servicing, read and carefully follow all the precautions and procedures which are described in this manual.
2. Do not use any electrical test equipment on or near SRS components, except those specified on GROUP 52B.
3. **Never Attempt to Repair the Following Components:**
  - SRS Air bag Control Unit (SRS-ECU)
  - Clock Spring
  - Air Bag Module (Driver's side or front passenger's side\*)
  - Seat Belt with Pre-tensioner

**NOTE**

\*: Vehicles with front passenger's air bag  
 If any of these components are diagnosed as faulty, they should only be replaced, in accordance with the **INDIVIDUAL COMPONENTS SERVICE** procedures in this manual, starting at page GROUP 52B.

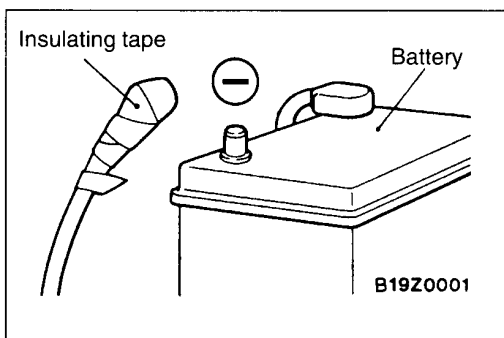

4. **After disconnecting the battery cable, with 60 seconds or more before proceeding with the following work. The SRS system is designed to retain enough voltage to deploy the air bag for a short time even after the battery has been disconnected, so serious injury may result from unintended air bag deployment if work is done on the SRS system immediately after the battery cables are disconnected.**

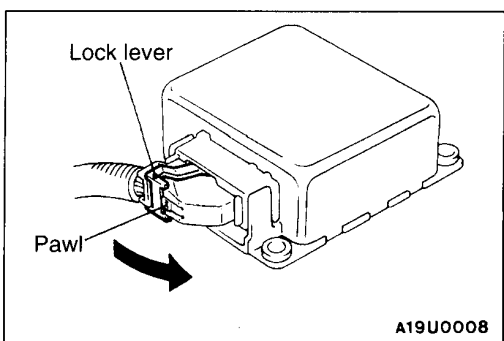

5. To disconnect the SRS-ECU connector, push the connector pawl to unlock the connector, and then turn the lock lever in the direction of the arrow.

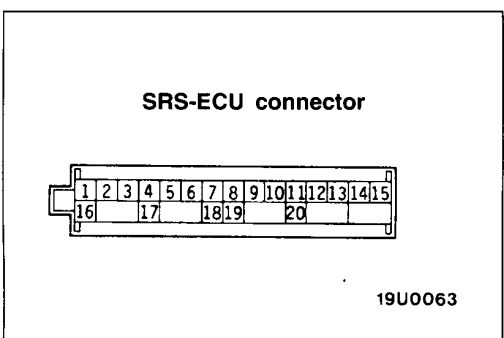

6. Do not attempt to repair the wiring harness connectors of the SRS. If any of the connectors are diagnosed as faulty, replace the wiring harness. If the wires are diagnosed as faulty, replace or repair the wiring harness according to the following table.



Harness Connector (No. of Terminal, Colour)	SRS-ECU Terminal No.	Destination of Harness	Corrective Action
20 pins, orange	1	Body wiring harness → Earth	Correct or replace each wiring harness.
	10		
	2*	Body wiring harness → Air bag module (Front passenger's side)	
	3*		
	4	Body wiring harness → Junction block (fuse No. 11)	
	5	Body wiring harness → Clock spring → Air bag module (Driver's side)	Correct or replace each wiring harness. Replace clock spring.
	6		
	7	Body wiring harness → Diagnosis connector	Correct or replace each wiring harness.
	8	Body wiring harness → Combination meter (SRS warning lamp)	
	9		
	11	Body wiring harness → Junction block (fuse No. 4)	
	12	Body wiring harness → Seat belt with pre-tensioner (Front passenger's side)	
	13		
	14	Body wiring harness → Seat belt with pre-tensioner (Driver's side)	
15			
16-20	–	–	

**NOTE**

\*: Vehicles with front passenger's air bag.

7. SRS component and seat belt with pre-tensioner should not be subjected to heat, so remove the SRS-ECU, air bag module, clock spring and seat belt with pre-tensioner before drying or baking the vehicle after painting.
  - SRS-ECU, air bag module, clock spring: 93°C or more
  - Seat belt with pre-tensioner: 90°C or more
8. Whenever you finish servicing the SRS, check warning lamp operation to make sure that the system functions properly. (Refer to GROUP 52B.)
9. Make certain that the ignition switch is OFF when the MUT-II is connected or disconnected.
10. If you have any questions about SRS, please contact your local distributor.

**NOTE**

SERIOUS INJURY CAN RESULT FROM UNINTENDED AIR BAG DEPLOYMENT, SO USE ONLY THE PROCEDURES AND EQUIPMENT SPECIFIED IN THIS MANUAL.

SUPPORT LOCATIONS FOR LIFTING AND JACKING

00100070027

Caution

Do not support the vehicles at locations other than specified supporting points. If do so, this will cause damage, etc.

SUPPORT POSITIONS FOR A GARAGE JACK AND AXLE STANDS

GARAGE JACK

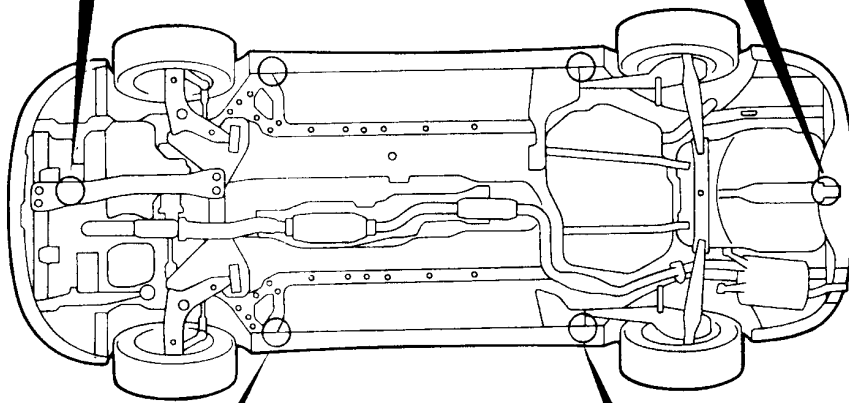
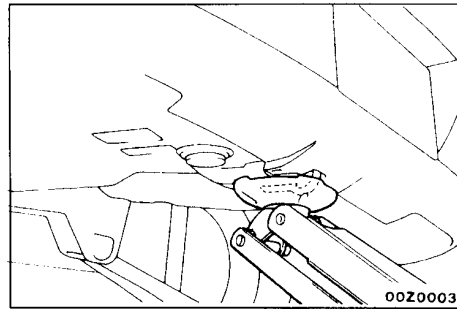
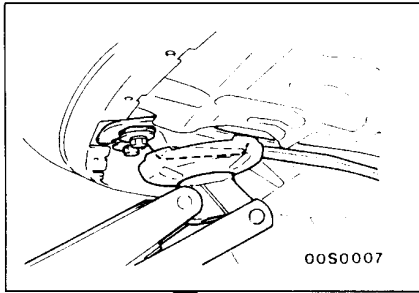

00U0007

AXLE STANDS

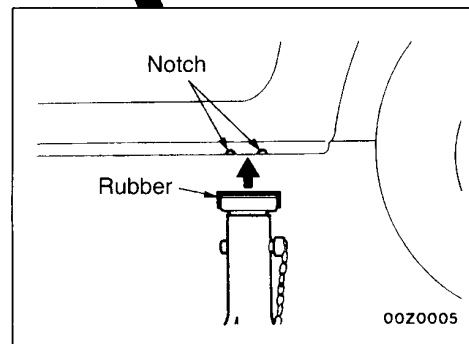
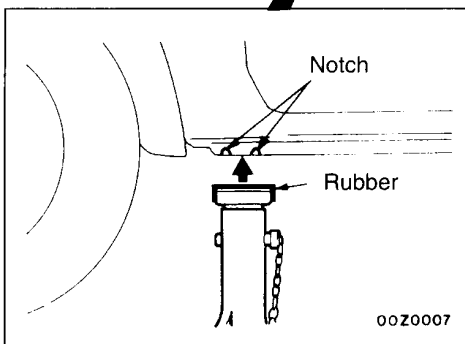

00003478

**SUPPORT POSITIONS FOR A SINGLE-POST LIFT OR DOUBLE-POST LIFT**

**Caution**  
When service procedures require removing rear suspension, spare tyre and rear bumper, place additional weight on rear end of vehicle or anchor vehicle to hoist to prevent tipping of centre of gravity changes.

**DOUBLE-POST LIFT**

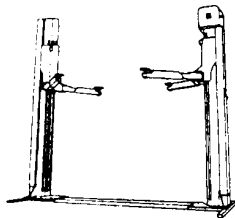

00E610

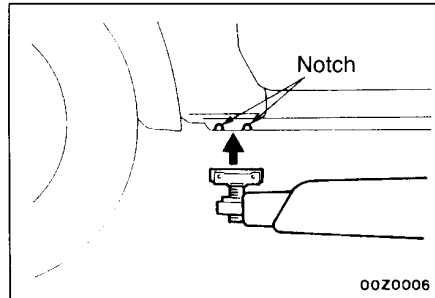

00Z0006

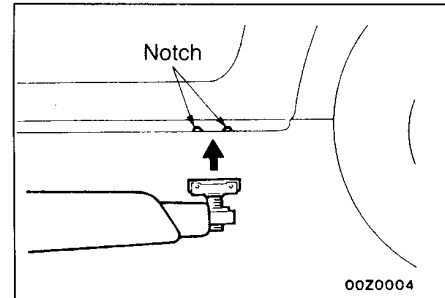

00Z0004

**SINGLE-POST LIFT**

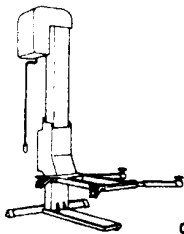

00E609

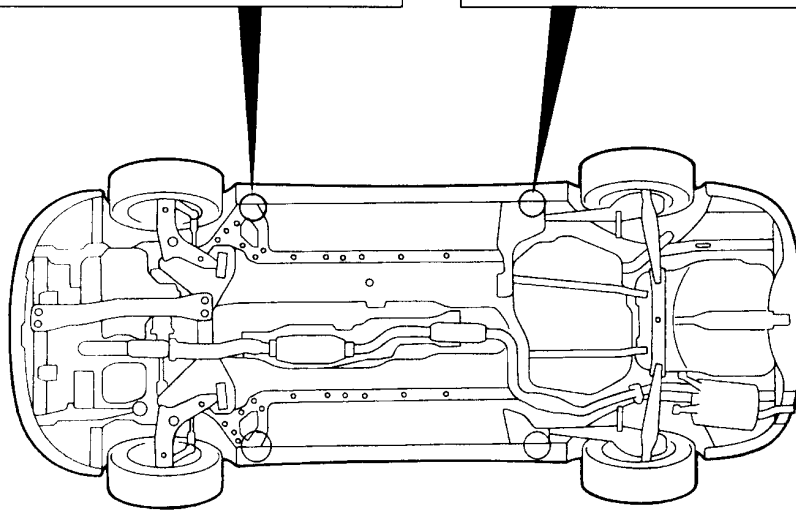

00U0007

00003479

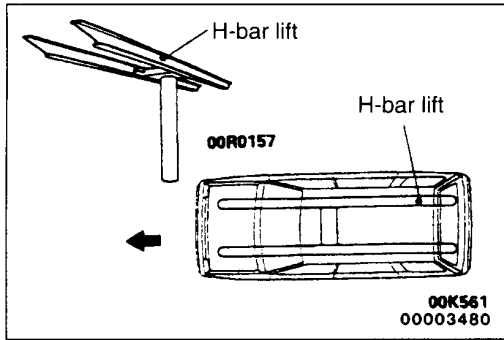

**SUPPORT POSITIONS AND SUPPORT METHOD FOR AN H-BAR LIFT**

**Caution**

When service procedures require removing rear suspension, fuel tank, spare tyre and rear bumper, place additional weight on rear end of vehicle or anchor vehicle to hoist to prevent tipping of centre of gravity changes.

When H-bar lift is used to lift up vehicles, use of metallic attachment attached to the H-bar lift may cause damage to the suspension arm etc. Therefore, lift up the vehicle by the following procedure.

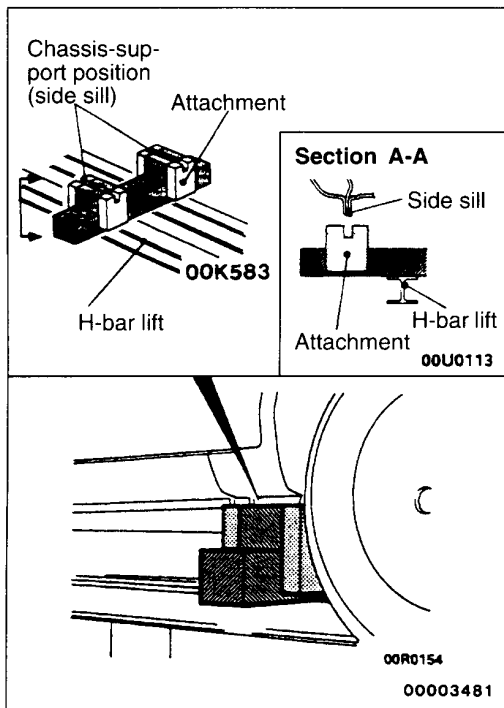

1. Place the vehicle on the H-bar lift (same direction).
2. Place attachments on the H-bar lift at the designated chassis-support positions. When making the attachments, refer to the section concerning making them.

**Caution**

If support is at any location other than the designated positions, the body or suspension might be deformed or otherwise damaged, so care should be taken to support only at the correct (designated) positions.

3. Raise the H-bar lift to the height at which the vehicle is slightly raised and check to be sure that the vehicle is correctly and sufficiently secured; then raise the vehicle.

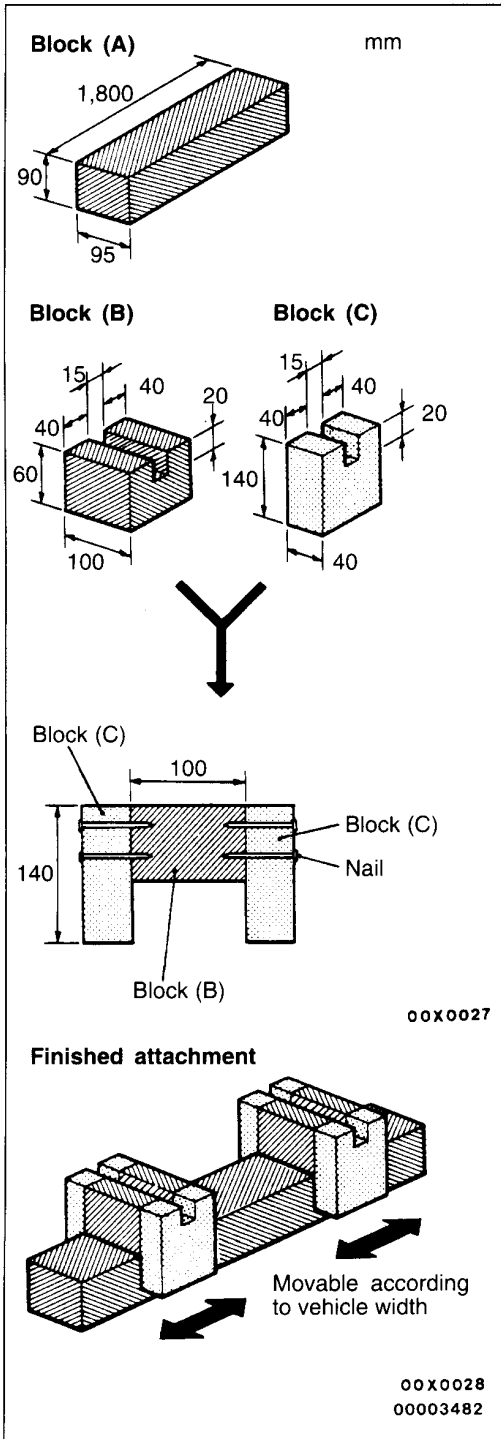

**PREPARATION OF “ATTACHMENTS”**

1. Prepare the blocks (wooden) and nails as shown in the figure.

Item	Dimensions mm	Quantity
Block (A)	90 × 95 × 1,800	2
Block (B)	60 × 100 × 95	4
Block (C)	140 × 40 × 95	8
Nail	70 or more	32

**Caution**

**The wood selected for the blocks must be hard.**

2. For the (B) blocks and (C) blocks, use a saw and chisel or similar tool to make grooves of the dimensions shown in the figure.
3. Make four “ATTACHMENTS” such as shown in the figure nailing (B) and (C) blocks so that each (B) blocks is sandwiches between (C) blocks.

**STANDARD PARTS-TIGHTENING-TORQUE TABLE**

00100110033

Each torque value in the table is a standard value for tightening under the following conditions.

- (1) Bolts, nuts and washers are all made of steel and plated with zinc.
- (2) The threads and bearing surface of bolts and nuts are all in dry condition.

The values in the table are not applicable:

- (1) If toothed washers are inserted.
- (2) If plastic parts are fastened.
- (3) If bolts are tightened to plastic or die-cast inserted nuts.
- (4) If self-tapping screws or self-locking nuts are used.

**Standard bolt and nut tightening torque**

Thread size		Torque Nm		
Bolt nominal diameter (mm)	Pitch (mm)	Head mark "4"	Head mark "7"	Head mark "8"
M5	0.8	2.5	4.9	5.9
M6	1.0	4.9	8.8	9.8
M8	1.25	12	22	25
M10	1.25	24	44	52
M12	1.25	41	81	96
M14	1.5	72	137	157
M16	1.5	111	206	235
M18	1.5	167	304	343
M20	1.5	226	412	481
M22	1.5	304	559	647
M24	1.5	392	735	853

**Flange bolt and nut tightening torque**

Thread size		Torque Nm		
Bolt nominal diameter (mm)	Pitch (mm)	Head mark "4"	Head mark "7"	Head mark "8"
M6	1.0	4.9	9.8	12
M8	1.25	13	24	28
M10	1.25	26	49	57
M10	1.5	24	44	54
M12	1.25	46	93	103
M12	1.75	42	81	96