

4G9 ENGINE

CONTENTS

1110900085

GENERAL INFORMATION	2	CRANKSHAFT PULLEY	19
SERVICE SPECIFICATIONS	2	CAMSHAFT, CAMSHAFT OIL SEAL <SOHC>	20
SEALANTS	4	CAMSHAFT, CAMSHAFT OIL SEAL <DOHC>	22
SPECIAL TOOLS	4	OIL PAN <SOHC>	25
ON-VEHICLE SERVICE	6	OIL PAN <DOHC>	26
Drive Belt Tension Check and Adjustment	6	CRANKSHAFT OIL SEAL	28
Valve Clearance Check and Adjustment <SOHC>	8	CYLINDER HEAD GASKET <SOHC>	30
Ignition Timing Check and Adjustment <SOHC>	9	CYLINDER HEAD GASKET <DOHC>	35
Ignition Timing Check and Adjustment <DOHC>	10	TIMING BELT <SOHC>	40
Idle Speed Check	11	TIMING BELT <DOHC>	43
Idle Mixture Check	12	ENGINE ASSEMBLY <SOHC>	48
Compression Pressure Check	13	ENGINE ASSEMBLY <DOHC>	52
Manifold Vacuum Check	14		
Lash Adjuster Check <DOHC>	15		
Timing Belt Tension Adjustment <SOHC>	18		

11A-2**4G9 ENGINE – General Information/Service Specifications****GENERAL INFORMATION**

11100010087

Items		4G92	4G93	4G93	
Total displacement ml		1,597	1,834	1,834	
Bore × Stroke mm		81.0×77.5	81.0×89.0	81.0×89.0	
Compression ratio		10.0	10.0	10.5	
Combustion chamber		Pentroof type	Pentroof type	Pentroof type	
Camshaft arrangement		SOHC	SOHC	DOHC	
Number of valve	Intake	8	8	8	
	Exhaust	8	8	8	
Valve timing	Intake	Opening	20	14	20
		Closing	42	50	60
	Exhaust	Opening	54	58	61
		Closing	2	10	15
Fuel system		Electronic control multipoint fuel injection	Electronic control multipoint fuel injection	Electronic control multipoint fuel injection	
Rocker arm		Roller type	Roller type	Roller type	
Auto-lash adjuster		Not equipped	Not equipped	Equipped	

SERVICE SPECIFICATIONS

11100030106

Items			Standard value	Limit
Alternator drive belt tension	Tension N	When checked	294–490	–
		When a used belt is installed	343–441	–
		When a new belt is installed	490–686	–
	Deflection (Reference value) mm	When checked	8.0–10.5	–
		When a used belt is installed	8.5–10.0	–
		When a new belt is installed	7.0–8.0	–

Items		Standard value	Limit	
Power steering oil pump and A/C compressor drive belt tension	Tension N	When checked	392–588	–
		When a used belt is installed	441–539	–
		When a new belt is installed	637–833	–
	Deflection (Reference value) mm	When checked	10.0–12.0	–
		When a used belt is installed	10.0–11.0	–
		When a new belt is installed	7.0–9.0	–
Valve clearance (at hot) mm <SOHC>	Intake valve	0.20	–	
	Exhaust valve	0.30	–	
Basic ignition timing	SOHC	5° BTDC±2°	–	
	DOHC	5° BTDC±3°	–	
Idle speed r/min	4G92–SOHC	750±100	–	
	4G93–SOHC, 4G93–DOHC	800±100	–	
CO contents %		0.5 or less	–	
HC contents ppm		100 or less	–	
Compression pressure (250–400 r/min) kPa	SOHC	1,270	min. 960	
	DOHC	1,320	min. 1,000	
Compression pressure difference of all cylinder kPa		–	max. 100	
Intake manifold vacuum kPa		min. 60	–	
Cylinder head bolt shank length mm		–	96.4	
Auto-tensioner push rod movement mm		Within 1	–	
Timing belt tension torque Nm (Reference value)		2.5–4.0	–	
Auto tensioner rod protrusion mm		3.8–4.5	–	

SEALANTS

11100050102

Items	Specified sealant	Remarks
Cam cup <DOHC> Rocker cover and cylinder head <DOHC> Semi-circular packing	3M ATD Part No. 8660 or equivalent	Semi-drying sealant
Oil pan Thermostat case	MITSUBISHI GENUINE PART MD970389 or equivalent	
Fly wheel bolt <M/T> or drive plate bolt <A/T>	3M Stud locking 4170 or equivalent	

SPECIAL TOOLS

11100060105

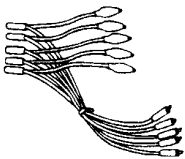
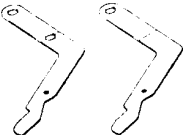
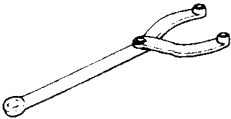
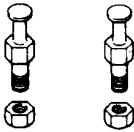
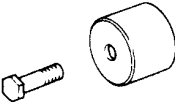
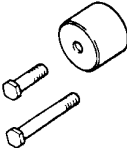
Tool	Number	Name	Use
	MB991348	Test harness set	Check the idle speed
	MD998782	Valve lifter set	Removal of roller rocker arm
	MB990767	End yoke holder	<ul style="list-style-type: none"> • Holding the camshaft pulley <SOHC> • Holding the crankshaft pulley
	MD998719 or MD998754	Crankshaft pulley holder pin	
	MD998713	Camshaft oil seal installer	Press-in of the camshaft oil seal
	MD998761	Camshaft oil seal installer	Press-in of the circular packing <DOHC>

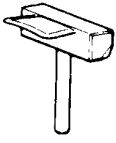
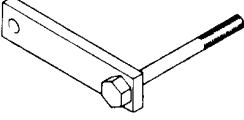
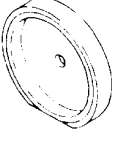
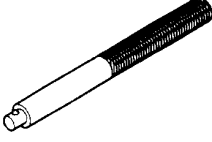
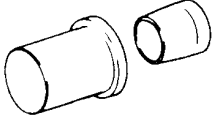
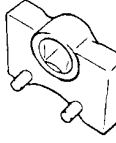
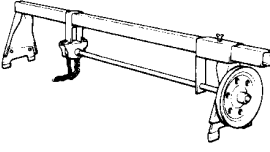
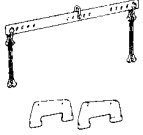
Tool	Number	Name	Use
	MD998727	Oil pan remover	Removing the oil pan <SOHC>
	MD998781	Fly wheel stopper	Securing the flywheel <M/T> or drive plate <A/T>
	MD998776	Crankshaft rear oil seal installer	Press-fitting the crankshaft rear oil seal
	MB990938	Handle	Press-fitting the crankshaft rear oil seal
	MD998717	Crankshaft front oil seal installer	Press-fitting the crankshaft front oil seal
	MD998767	Tension pulley socket wrench	Timing belt tension adjustment <DOHC>
	GENERAL SERVICE TOOL MZ203827	Engine lifter	Supporting the engine assembly during removal and installation of the transmission
	MB991453	Engine hanger assembly	

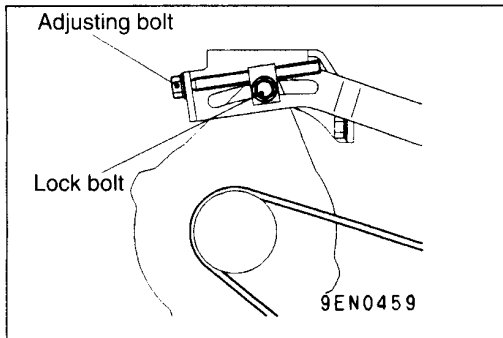
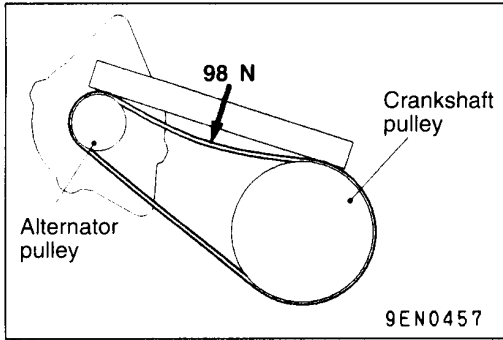

ON-VEHICLE SERVICE

DRIVE BELT TENSION CHECK AND ADJUSTMENT

ALTERNATOR DRIVE BELT TENSION CHECK

Use a belt tension gauge to check that the belt tension is at the standard value at a point half-way between the two pulleys as shown in the illustration. In addition, press this section with a force of 98 N and check that the amount of belt deflection is at the standard value.

Standard value:

Tension N	294–490
Deflection (Reference value) mm	8.0–10.5

ALTERNATOR DRIVE BELT TENSION ADJUSTMENT

1. Loosen the nut of the alternator pivot bolt.
2. Loosen the lock bolt.
3. Use the adjusting bolt to adjust the belt tension and belt deflection to the standard values.

Standard value:

Items	When a used belt is installed	When a new belt is installed
Tension N	343–441	490–686
Deflection (Reference value) mm	8.5–10.0	7.0–8.0

4. Tighten the lock bolt.
Tightening torque: 23 Nm
5. Tighten the nut of the alternator pivot bolt.
Tightening torque: 44 Nm
6. Tighten the adjusting bolt.
Tightening torque: 6 Nm

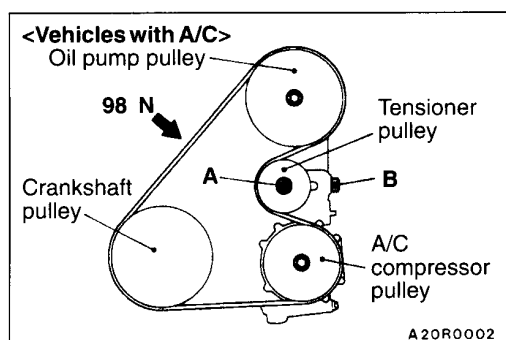
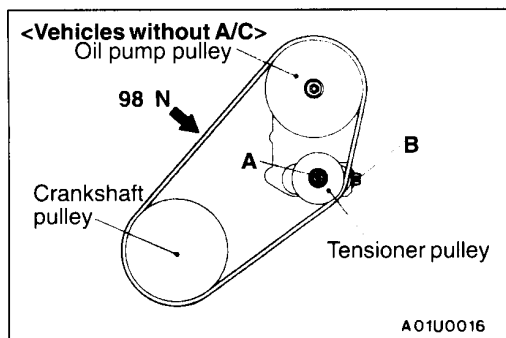

POWER STEERING OIL PUMP AND AIR CONDITIONER COMPRESSOR DRIVE BELT TENSION CHECK AND ADJUSTMENT

11100130035

1. Use a belt tension gauge to check that the belt tension is at the standard value at a point half-way between the two pulleys (indicated by an arrow in the illustration). In addition, press this section with a force of 98 N and check that the amount of belt deflection is at the standard value.

Standard value:

Items	When checked	When a used belt is installed	When a new belt is installed
Tension N	392–588	441–539	637–833
Deflection mm	10.0–12.0	10.0–11.0	7.0–9.0

2. If the tension or deflection is outside the standard value, adjust by the following procedure.
 - (1) Loosen tension pulley fixing bolt A.
 - (2) Adjust the amount of belt deflection using adjusting bolt B.
 - (3) Tighten fixing bolt A.
 - (4) Check the belt deflection amount and tension, and readjust if necessary.

Caution

- Check after turning the crankshaft once or more clockwise (right turn).

VALVE CLEARANCE CHECK AND ADJUSTMENT <SOHC>

11100150031

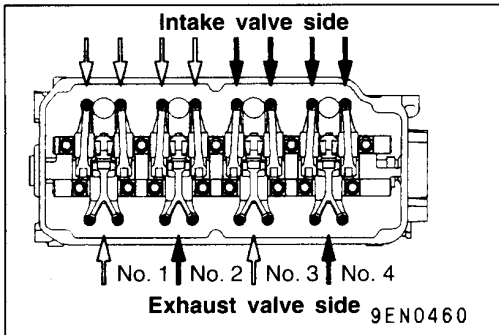

1. Start the engine and allow it to warm up until the engine coolant temperature reaches 80 to 95°C.
2. Remove all spark plugs from the cylinder head for easy inspection.
3. Remove the rocker cover.
4. Turn the crankshaft clockwise until the notch on the pulley is lined up with the "T" mark on the timing indicator.
5. Move the rocker arms on the No. 1 and No. 4 cylinders up and down by hand to determine which cylinder has its piston at the top dead centre on the compression stroke. If both intake and exhaust valve rocker arms have a valve lash, the piston in the cylinder corresponding to these rocker arms is at the top dead centre on the compression stroke.
6. Valve clearance inspection and adjustment can be performed on rocker arms indicated by white arrow mark when the No. 1 cylinder piston is at the top dead centre on the compression stroke, and on rocker arms indicated by black arrow mark when the No. 4 cylinder piston is at the top dead centre on the compression stroke.
7. Measure the valve clearance.
If the valve clearance is not as specified, loosen the rocker arm lock nut and adjust the clearance using a thickness gauge while turning the adjusting screw.
8. While holding the adjusting screw with a screwdriver to prevent it from turning, tighten the lock nut to the specified torque.

Standard value (hot engine):

Intake valve: 0.20 mm

Exhaust valve: 0.30 mm

Tightening torque: 9 Nm

9. Turn the crankshaft through 360° to line up the notch on the crankshaft pulley with the "T" mark on the timing indicator.
10. Repeat steps (7) and (8) on other valves for clearance adjustment.
11. Install the rocker cover.
12. Install the spark plugs and tighten to the specified torque.

Tightening torque: 25 Nm

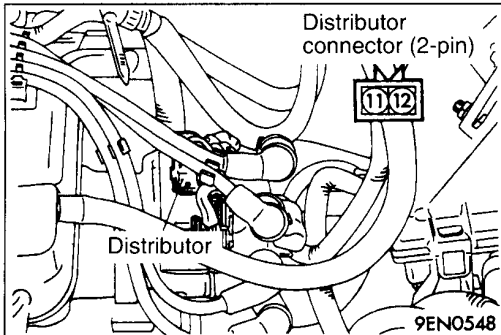

IGNITION TIMING CHECK AND ADJUSTMENT <SOHC>

11100160072

1. Before inspection, set the vehicle to the pre-inspection condition.
2. Disconnect the distributor connector (2-pin), and connect the special tool (test harness set: MB991348) in between. All terminals should be connected.
3. Connect a primary voltage-detection type of tachometer to terminal (12) of the distributor connector.

NOTE

Do not use the MUT-II.

If tested with the MUT-II connected to the diagnosis connector, the ignition timing will not be the basic timing but be ordinary timing.

4. Set up a timing light.
5. Start the engine and run it at idle.
6. Check that engine idle speed is within the standard value.

Standard value:

4G92 engine: 750±100 r/min

4G93 engine: 800±100 r/min

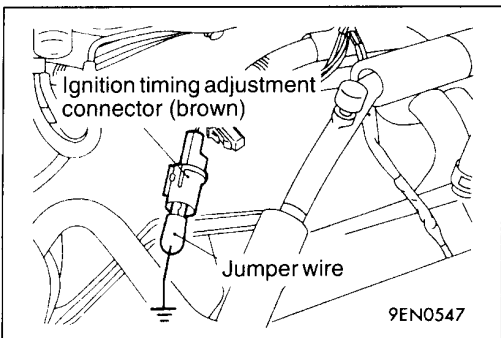

7. Turn the ignition switch to OFF.
8. Remove the waterproof connector from the ignition timing adjustment connector (brown).
9. Connect the jumper wire with the clip to the ignition timing adjustment terminal, and earth this to the body as illustrated.

NOTE

Earthing this terminal sets the engine to the basic ignition timing.

10. Start the engine and run it at idle.

11. Check that basic ignition timing is within the standard value.

Standard value: 5° BTDC \pm 2°

12. If not within the standard value, loosen distributor mounting bolt and adjust by rotating distributor body.
13. Tighten mounting bolt after adjusting.

Tightening torque: 24 Nm

14. Stop the engine, remove the jumper wire from the ignition timing adjustment connector (brown), and return the connector to its original condition.
15. Start the engine and check that ignition timing at the standard value.

Standard value: Approx. 10° BTDC

NOTE

1. Ignition timing is variable within about $\pm 7^\circ$, even under normal operating.
 2. And it is automatically further advanced by about 5° from 10° BTDC at higher altitudes.
16. Sealing tape is to be attached to the fitting nut only for vehicles for Switzerland.

NOTE

Sealing tape is attached to all vehicles when new.

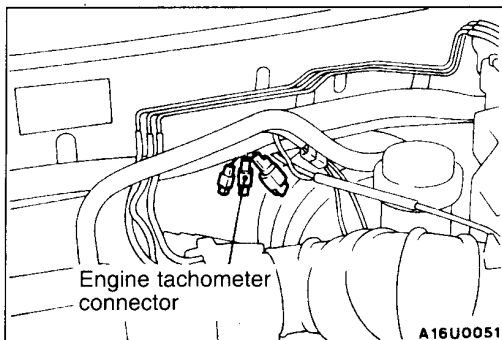

IGNITION TIMING CHECK AND ADJUSTMENT <DOHC>

11100170013

1. Before inspection, set the vehicle to the pre-inspection condition.
2. Insert a paper clip from the harness side into the 1 pin connector as shown in the illustration at left.
3. Connect a primary-voltage-detection type of tachometer to the paper clip.

NOTE

Do not use the MUT-II.

If tested with the MUT-II connected to the diagnosis connector, the ignition timing will not be the basic timing but be ordinary timing.

4. Set up a timing light.
5. Start the engine and run at idle.
6. Check that engine idle speed is within the standard value.

Standard value: 800 \pm 100 r/min

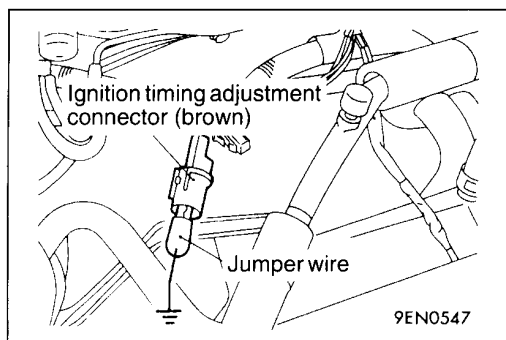

7. Turn the ignition switch to OFF.
8. Remove the waterproof connector from the ignition timing adjustment connector (brown).
9. Connect the jumper wire with the clip to the ignition timing adjustment terminal, and earth this to the body as illustrated.

NOTE

Earthing this terminal sets the engine to the basic ignition timing.

10. Start the engine and run it at idle.
 11. Check that basic ignition timing is within the standard value.
- Standard value: 5° BTDC±3°**
12. If the basic ignition timing is outside the standard value, inspect the MPI system while referring to GROUP 13A – Troubleshooting.
 13. Stop the engine, remove the jumper wire from the ignition timing adjustment connector (brown), and return the connector to its original condition.
 14. Start the engine and check that ignition timing at the standard value.

Standard value: Approx. 8° BTDC

NOTE

1. Ignition timing is variable within about ± 7°, even under normal operating.
2. And it is automatically further advanced by about 5° from 8° BTDC at higher altitudes.

IDLE SPEED CHECK

11100190088

1. Before inspection, set the vehicle to the pre-inspection condition.
2. Check the basic ignition timing. Adjust if necessary.

Standard value:

SOHC: 5° BTDC±2°

DOHC: 5° BTDC±3°

3. After turning the ignition switch to OFF, connect the MUT-II to the diagnosis connector.
4. Start the engine and run it at idle.
5. Run the engine at idle for 2 minutes.
6. Check the idle speed. Select item No. 22 and take a reading of the idle speed.

Curb idle speed:

4G92 engine: 750±100 r/min

4G93 engine: 800±100 r/min

NOTE

The idle speed is controlled automatically by the idle speed control (ISC) system.

7. If the idle speed is outside the standard value, inspect the MPI components by referring to GROUP 13A – Troubleshooting.

IDLE MIXTURE CHECK

11100210036

1. Before inspection, set the vehicle to the pre-inspection condition.
2. Check that the basic ignition timing is within the standard value.

Standard value:**SOHC: 5° BTDC±2°****DOHC: 5° BTDC±3°**

3. Turn the ignition switch to OFF and connect the MUT-II to the diagnosis connector.
4. Start the engine and run it at 2,500 r/min for 2 minutes.
5. Set the CO, HC tester.
6. Check the CO contents and the HC contents at idle.

Standard value**CO contents: 0.5% or less****HC contents: 100 ppm or less**

7. If there is a deviation from the standard value, check the following items:
 - Diagnosis output
 - Closed-loop control (When the closed-loop control is normal, the output signal of the oxygen sensor changes between 0–400 mV and 600–1,000 mV at idle.)
 - Combustion pressure
 - Injector
 - Ignition coil, spark plug cable, spark plug
 - Leak in the EGR system and in the EGR valve
 - Evaporative emission control system
 - Compression pressure

NOTE

Replace the three way catalyst when the CO and HC contents are not within the standard value, even though the result of the inspection is normal on all items.

COMPRESSION PRESSURE CHECK

11100260086

1. Before inspection, check that the engine oil, starter and battery are normal. In addition, set the vehicle to the pre-inspection condition.
2. Disconnect the spark plug cables.
3. Remove all of the spark plugs.
4. Disconnect the distributor 6-pin connector <SOHC> or the crank angle sensor connector <DOHC>.

NOTE

Doing this will prevent the engine control unit from carrying out ignition and fuel injection.

5. Cover the spark plug hole with a shop towel etc., and after the engine has been cranked, check that no foreign material is adhering to the shop towel.

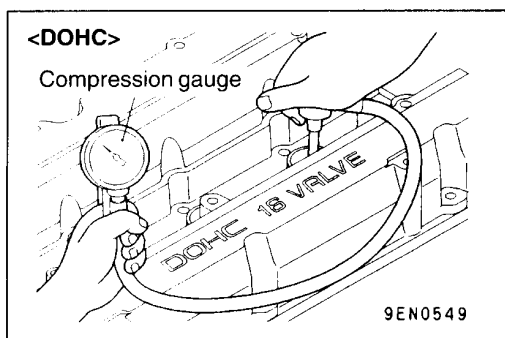
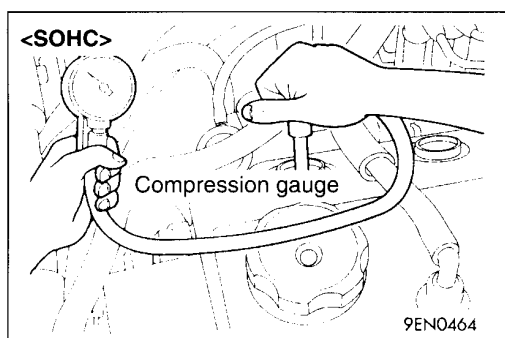
**Caution**

1. Keep away from the spark plug hole when cranking.
2. If compression is measured with water, oil, fuel, etc., that has come from cracks inside the cylinder, these materials will become heated and will gush out from the spark plug hole, which is dangerous.
6. Set compression gauge to one of the spark plug holes.
7. Crank the engine with the throttle valve fully open and measure the compression pressure.

Standard value (at engine speed of 250–400 r/min):**SOHC: 1,270 kPa****DOHC: 1,320 kPa****Limit (at engine speed of 250–400 r/min):****SOHC: min. 960 kPa****DOHC: min. 1,000 kPa**

8. Measure the compression pressure for all the cylinders, and check that the pressure differences of the cylinders are below the limit.

Limit: max. 100 kPa

9. If there is a cylinder with compression or a compression difference that is outside the limit, pour a small amount of engine oil through the spark plug hole, and repeat the operations in steps (7) and (8).

- (1) If the compression increases after oil is added, the cause of the malfunction is a worn or damaged piston ring and/or cylinder inner surface.
 - (2) If the compression does not rise after oil is added, the cause is a burnt or defective valve seat, or pressure is leaking from the gasket.
10. Connect the distributor connector.
 11. Install the spark plugs and spark plug cables.
 12. Use the MUT-II to erase the diagnosis codes.

NOTE

This will erase the problem code resulting from the distributor connector being disconnected.

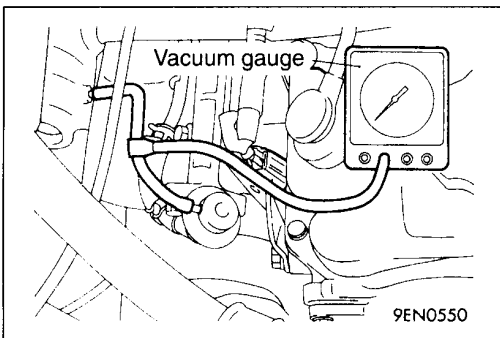
**MANIFOLD VACUUM CHECK**

11100270072

1. Start the engine and allow it to warm up until the temperature of the engine coolant reaches 80 to 95°C.
2. Connect a tachometer.
3. Attach a three-way union to the vacuum hose between the fuel pressure regulator and the air intake plenum, and connect a vacuum gauge.
4. Start the engine and check that idle speed is within specification. Then read off the vacuum gauge.

Standard value: min. 60 kPa

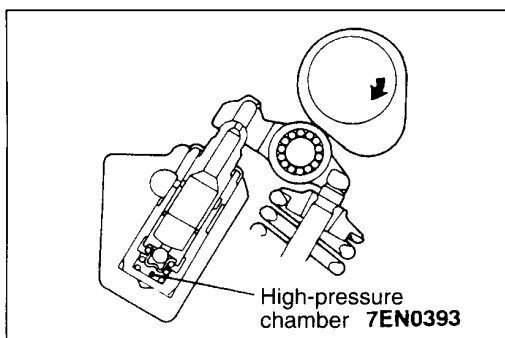
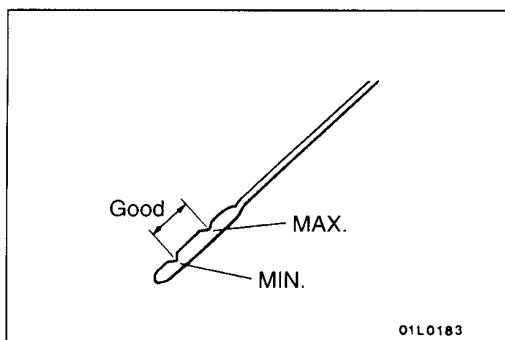
**LASH ADJUSTER CHECK <DOHC>**

11100290061

NOTE

Soon after the engine is started or while it is running, abnormal noise (clattering) which may be attributed to the adjuster sounds but does not stop. In this case, check the following.

1. Check the engine oil, and refill or replace oil if necessary.

NOTE

1. If the oil amount is small, air will be sucked from the oil strainer and mixed in the oil passage.
2. If the oil amount is excessive, the oil will be stirred by the crank and mixed with a large amount of air.
3. Air and oil can not be separated easily in the deteriorated oil, and the amount of air mixed in the oil increases.

If such mixed-in air enters the high pressure chamber in the lash adjuster, the air in the high-pressure chamber will be compressed while the valve is opened, the lash adjuster will be excessively compressed and abnormal noise will be produced when the valve is closed.

This is the same phenomenon which occurs when the valve clearance is improperly adjusted to be excessively large.

However, it will return to be normal if the air entrapped in the adjuster is released in this case.

2. Start the engine, and slowly race* it several times (10 times or less).

If the abnormal noise is eliminated by racing the engine, it means that the air is released from the high-pressure chamber of the lash adjuster and the function of the lash adjuster is returned to normal.

* Gradually increase the engine speed from the idle speed to 3,000 r/min (for 30 seconds), and then gradually slow down the engine to the idling speed (for 30 seconds).

NOTE

1. If the vehicle is parked on a slope for a long time, the oil will be sometimes reduced in the lash adjuster, and air will enter the high-pressure chamber when the engine is started.
2. After the vehicle is parked for a long time, the oil will go out of the oil passage. Since it takes a little time to supply oil to the lash adjuster, air sometimes enters the high-pressure chamber.

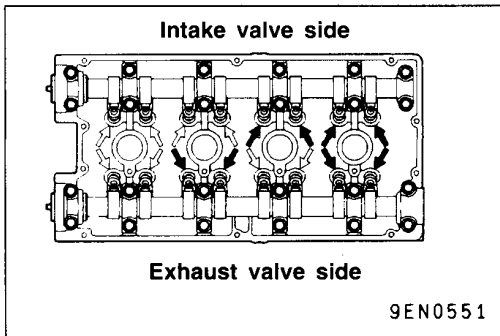

3. If any abnormal noise is not eliminated by racing, check the lash adjuster.
 - (1) Stop the engine.
 - (2) Set the engine so that cylinder No. 1 is positioned at the top dead centre of the compression.
 - (3) Press the rocker arm at the area indicated by the white arrow mark to check whether the rocker arm is lowered or not.
 - (4) Slowly turn the crankshaft 360 degrees clockwise.
 - (5) In the same procedure as step (3), check the rocker arm at the area indicated by the black arrow mark.
 - (6) If the rocker arm is easily lowered when the section directly above the lash adjuster of the rocker arm is pressed, the lash adjuster is defective, so replace it according to the procedure in step (4).
When the lash adjuster is replaced, bleed air from all adjusters and assemble them. Re-check them following steps (1) to (5).

NOTE

1. A leak down test can be performed to accurately determine whether the lash adjuster is defective or not.
2. For the procedures for the leak down test and air bleeding of the lash adjuster, refer to the Engine Workshop Manual.

Moreover, if it is felt to be so hard that the rocker arm is not lowered when it is pressed, the lash adjuster is normal. Check for other causes of the abnormality.

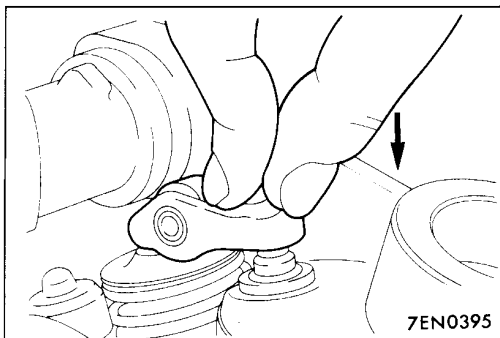

4. Lash adjuster replacement procedure.

Caution

In the cylinders which are being removed, the valves will touch the pistons when the valves are pushed down, so the crankshaft should be turned to lower the piston positions.

In addition, places where the rocker arms are lifted by the cams cannot be removed. In these cases, the crankshaft should be turned so that the rocker arms are not lifted.

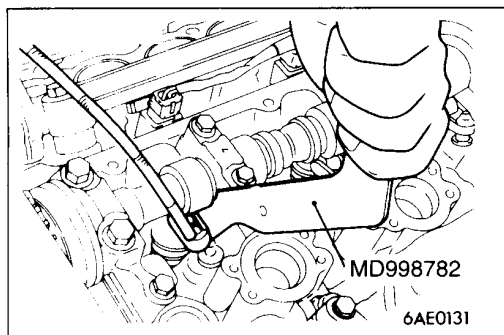

- (1) Use the special tool to push down the valve, and remove the roller rocker arm.
- (2) Remove the lash adjuster from the cylinder head.
- (3) Install a new lash adjuster from which the air has been bled to the cylinder head.

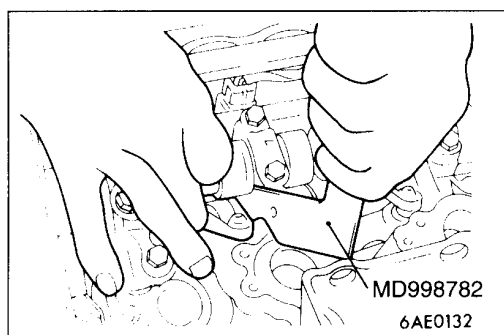

- (4) Use the special tool to push down the valve, and install the roller rocker arm.

NOTE

When installing the roller rocker arm, first set the pivot side of the rocker arm onto the top of the lash adjuster, and then after pushing down the valve, set the slipper side of the rocker arm on top of the end of the valve stem.

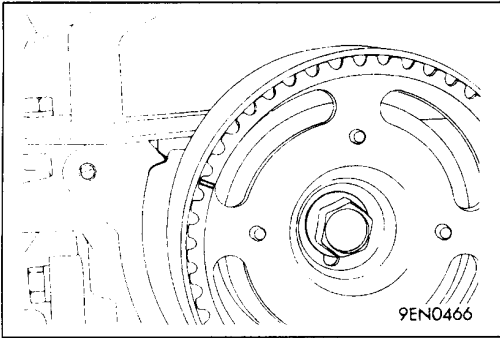
**TIMING BELT TENSION ADJUSTMENT <SOHC>**

11100280037

1. Remove the timing belt upper cover.
2. Turn the crankshaft clockwise to set the No. 1 cylinder to top dead compression centre.

Caution

As the purpose of this procedure is to apply the proper amount of tension to the timing belt by means of the cam drive torque, be sure not to rotate the crankshaft in the opposite direction.

3. Remove the access cover.
4. Loosen the timing belt tensioner fixing bolt to apply tension to the belt by means of the force of the tensioner spring.

Caution

The bolt can be loosened 80°–200°.

If the belt is loosened more than necessary, the bolt may fall in side the cover.

5. Tighten the timing belt tensioner fixing bolt.
6. Install the access cover.
7. Install the timing belt upper cover.

CRANKSHAFT PULLEY

11200160082

REMOVAL AND INSTALLATION

Pre-removal and Post-installation Operation
 • Under Cover (R.H.) Removal and Installation

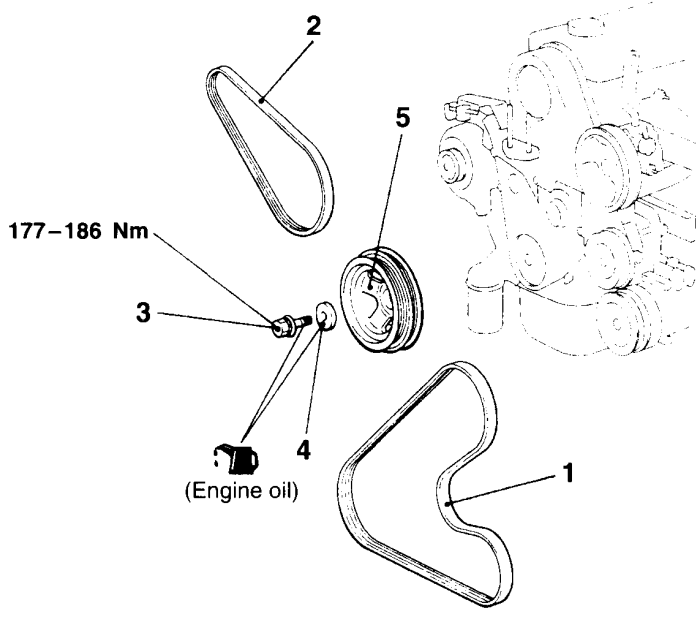

A01R0023

Removal steps

- Drive belt tension adjustment (Refer to P.11-6.)
- 1. Drive belt (Power steering and A/C)
- 2. Drive belt (Alternator)

- ◀A▶ ▶A◀ 3. Crankshaft pulley bolt
- 4. Crankshaft pulley washer
- 5. Crankshaft pulley

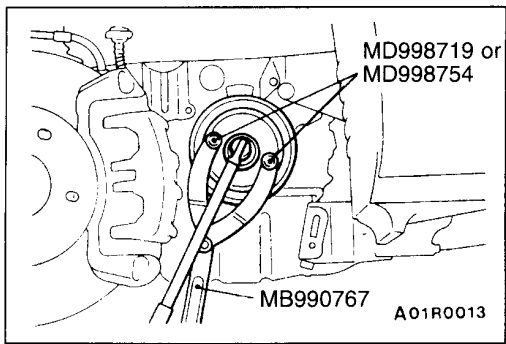

REMOVAL SERVICE POINT

◀A▶ **CRANKSHAFT PULLEY BOLT REMOVAL**

INSTALLATION SERVICE POINT

▶A◀ **CRANKSHAFT PULLEY BOLT INSTALLATION**

When installing the crankshaft bolt, apply the minimum amount of engine oil to the bearing surface and thread of the bolt.

CAMSHAFT AND CAMSHAFT OIL SEAL <SOHC>

11200190074

REMOVAL AND INSTALLATION

Pre-removal and Post-installation Operation

- Distributor Removal and Installation (Refer to GROUP 16.)
- Timing Belt Removal and Installation (Refer to P.11-40.)

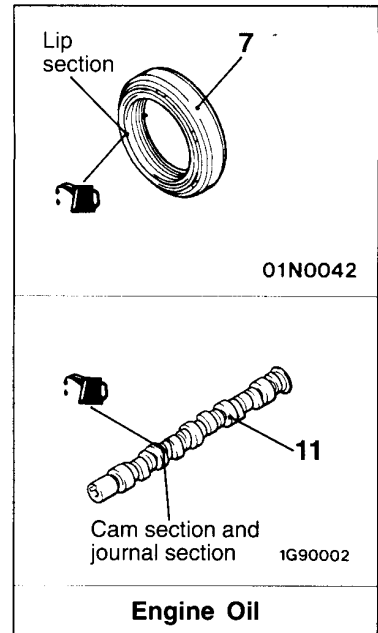
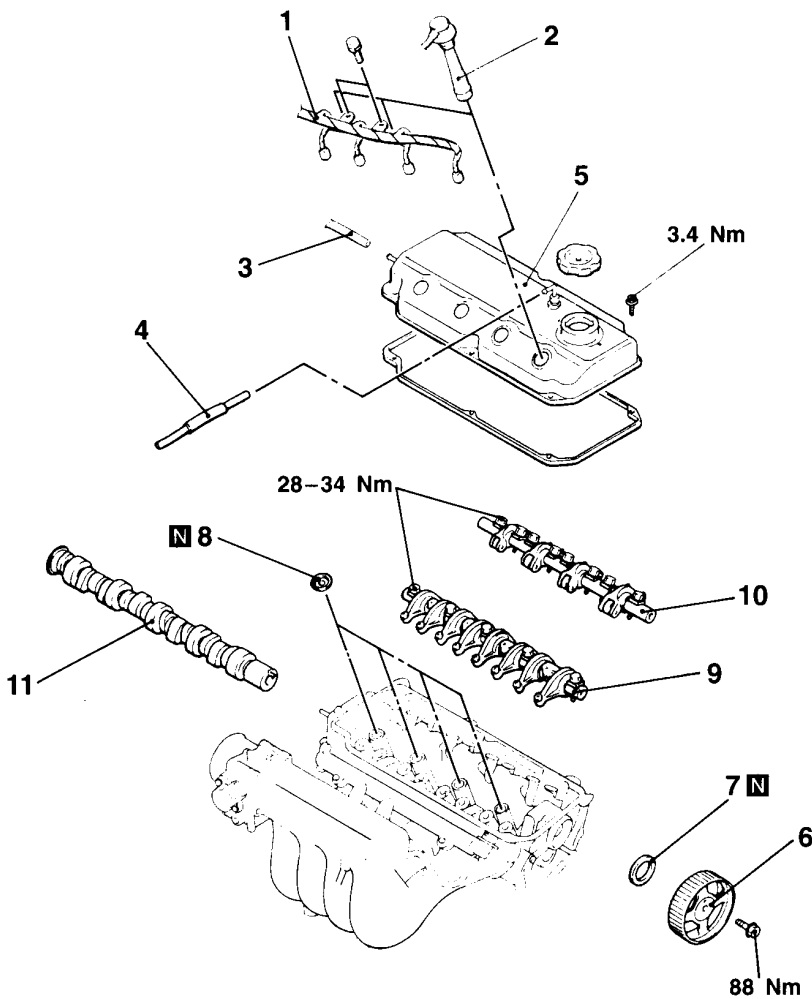

01U0019

00003392

Removal steps

1. Control harness connection
2. Spark plug cable
3. Breather hose connection
4. PCV hose connection
5. Rocker cover
 - Valve clearance adjustment (Refer to P.11-8.)
- ◀A▶ ▶B▶ 6. Camshaft sprocket

- ▶A▶ 7. Camshaft oil seal
8. Spark plug guide oil seal
- ◀B▶ 9. Rocker arm and shaft assembly (intake side)
- ◀B▶ 10. Rocker arm and shaft assembly (exhaust side)
11. Camshaft

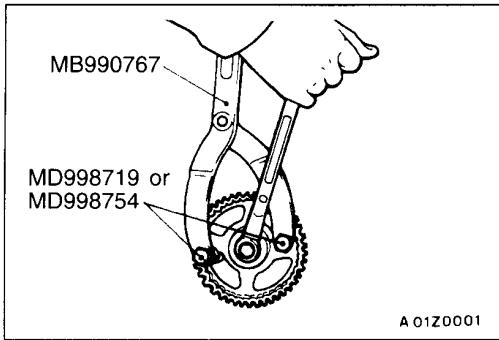
**REMOVAL SERVICE POINTS****◀A▶ CAMSHAFT SPROCKET REMOVAL****◀B▶ ROCKER ARM AND SHAFT ASSEMBLY REMOVAL**

Loosen the rocker arm and shaft assembly mounting bolt, and then remove the rocker arm and shaft assembly with the bolt still attached.

Caution

Never disassemble the rocker arm and shaft assembly.

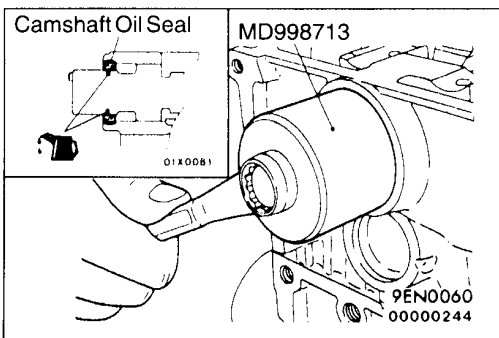
**INSTALLATION SERVICE POINTS****▶A▶ CAMSHAFT OIL SEAL INSTALLATION**

1. Apply engine oil to the camshaft oil seal lip.
2. Use the special tool to press-fit the camshaft oil seal.

▶B▶ CAMSHAFT SPROCKET INSTALLATION

Use the special tool to stop the camshaft sprocket from turning in the same way as was done during removal, and then tighten the bolts to the specified torque.

Specified torque: 88 Nm

CAMSHAFT AND CAMSHAFT OIL SEAL <DOHC>

11200190081

REMOVAL AND INSTALLATION

Pre-removal and Post-installation Operation
 • Timing Belt Removal and Installation
 (Refer to P.11-43.)

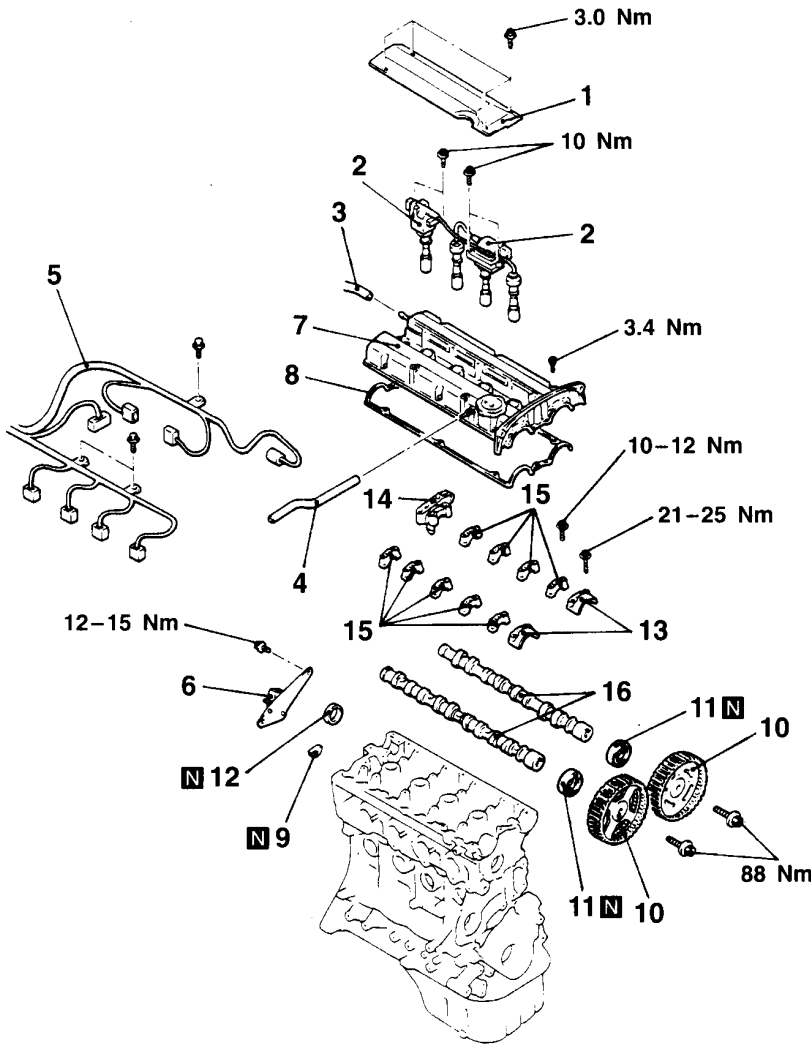

01U0040

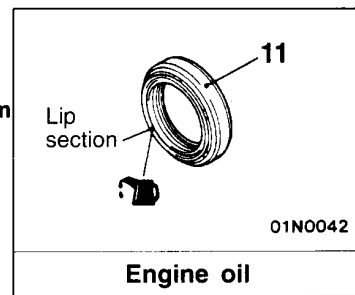
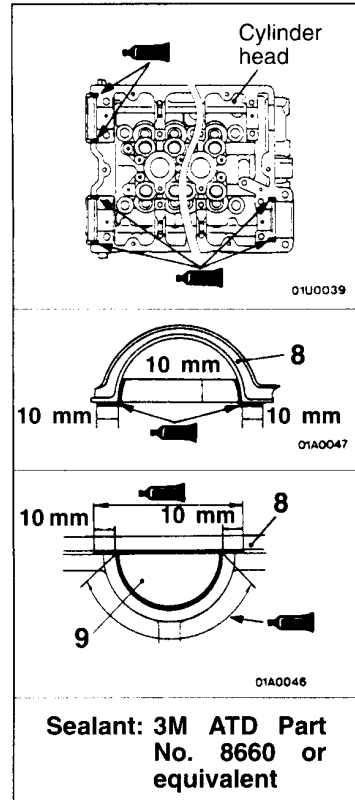

00003393

Removal steps

1. Center cover
2. Ignition coil assembly
3. Breather hose connection
4. PCV hose connection
5. Control harness connection
6. Ignition failure sensor assembly
7. Rocker cover
8. Rocker cover gasket

- | | | |
|-----|-----|--------------------------|
| ◀A▶ | ▶E▶ | 9. Semi-circular packing |
| ▶D▶ | ▶E▶ | 10. Camshaft sprocket |
| ▶C▶ | ▶E▶ | 11. Camshaft oil seal |
| ▶B▶ | ▶E▶ | 12. Circular packing |
| ▶B▶ | ▶E▶ | 13. Front cam cap |
| ▶B▶ | ▶E▶ | 14. Rear cam cap |
| ▶A▶ | ▶E▶ | 15. Cam cap |
| | ▶E▶ | 16. Camshaft |

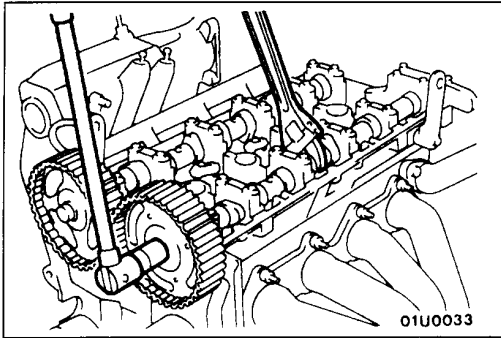

REMOVAL SERVICE POINT

◀A▶ CAMSHAFT SPROCKET REMOVAL

Hold the hexagonal section of the camshaft with a wrench, etc., and loosen the camshaft sprocket bolt.

Caution

As the sprocket could become damaged, do not apply the wrench to the camshaft sprocket.

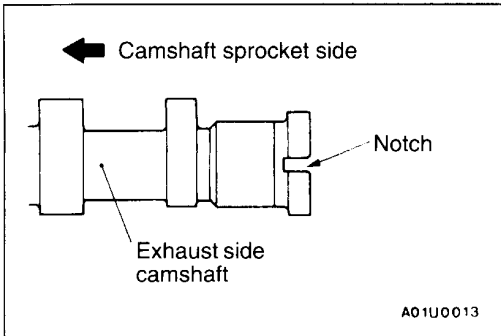

INSTALLATION SERVICE POINTS

▶A▶ CAMSHAFT INSTALLATION

1. Apply engine oil to journals and cams of the camshafts.
2. Install the camshafts on the cylinder head.
Be careful not to confuse the intake camshaft with the exhaust one. The exhaust camshaft has a notch on its rear end.

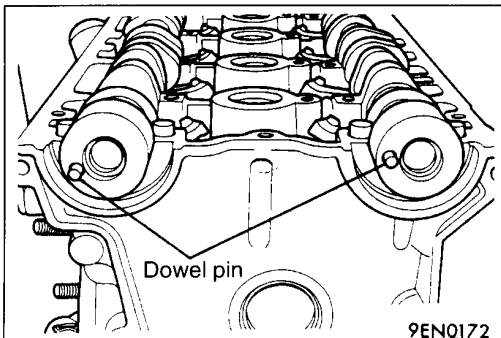

▶B▶ CAM CAP/REAR CAM CAP/FRONT CAM CAP INSTALLATION

1. Set the camshaft dowel pins in the positions shown in the illustration.

NOTE

Place the notch for tightening the camshaft head bolt in the correct position.

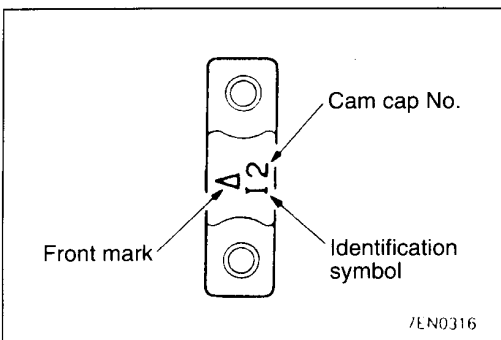

2. Check the identification symbols and the cap numbers of the bearing caps and install them so that they are aligned with the front marks on the cylinder head.

Identification symbol:

Intake side I

Exhaust side E

3. Apply specified sealant to the cylinder head in the specified places.

Specified sealant:

3M ATD Part No. 8660 or equivalent

4. After provisionally tightening the cam caps in 2–3 turns, tighten to the specified torque.

Specified torque:**Front and rear cam cap 21–25 Nm****Cam cap 10–12 Nm**

5. Check to ensure that the rocker arm is held in position on the lash adjuster and valve stem end.

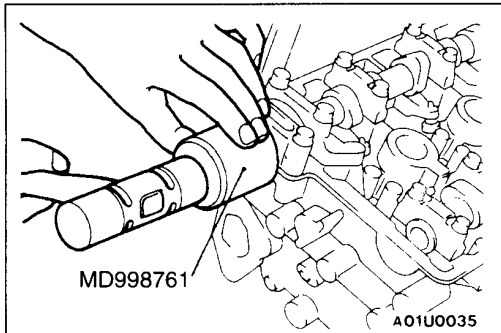
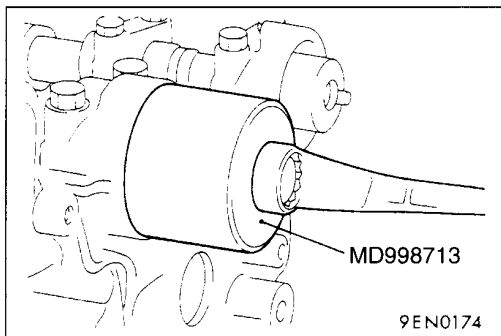
**►C◄ CIRCULAR PACKING INSTALLATION****►D◄ CAMSHAFT OIL SEAL INSTALLATION**

1. Apply engine oil to the camshaft oil seal lip.
2. Use the special tool to press-fit the camshaft oil seal.

►E◄ CAMSHAFT SPROCKET INSTALLATION

Use the special tool to stop the camshaft from turning in the same way as was done during removal, and then tighten the bolts to the specified torque.

Specified torque: 88 Nm

OIL PAN <SOHC>

REMOVAL AND INSTALLATION

Pre-removal and Post-installation Operation

- Engine Oil Draining and Supplying (Refer to GROUP 12 – On-vehicle Service.)
- Oil Level Gauge Removal and Installation
- Under Cover Removal and Installation

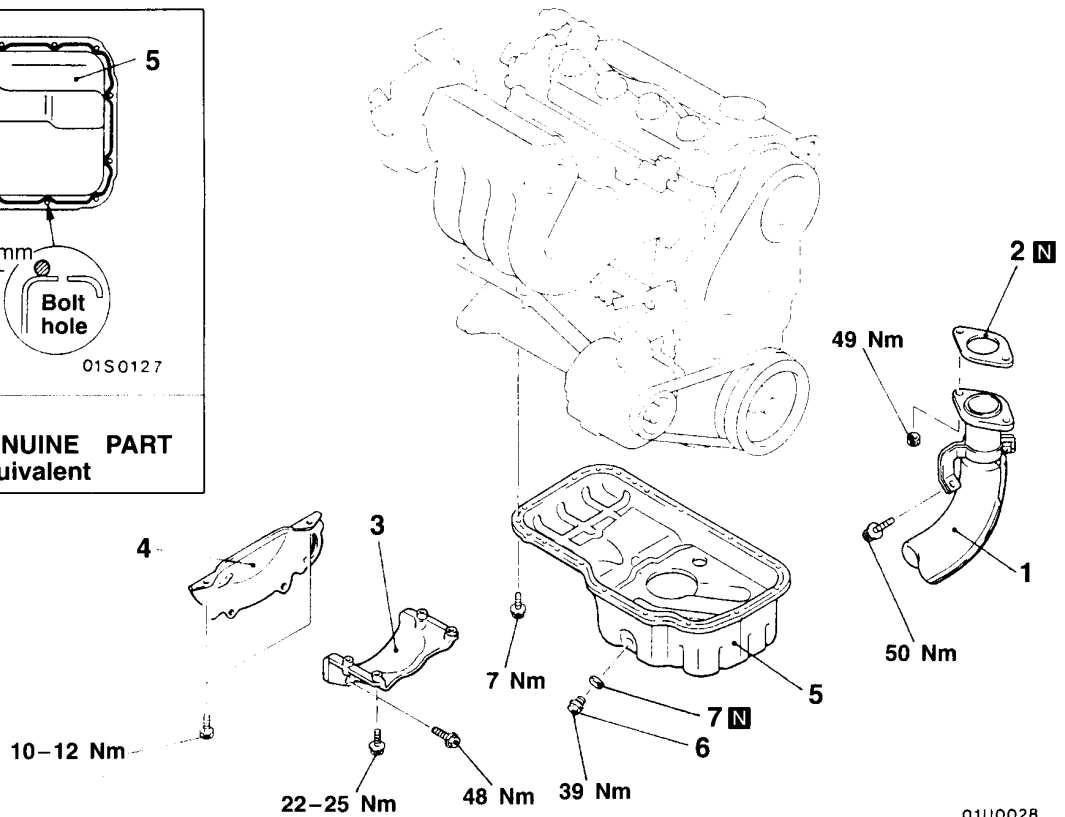
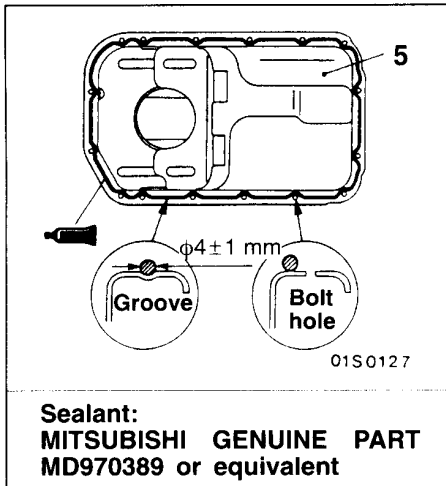

01U0028
00003394

Removal steps

1. Front exhaust pipe connection
2. Gasket
3. Transmission stay
4. Bell housing cover



5. Oil pan
6. Drain plug
7. Drain plug gasket

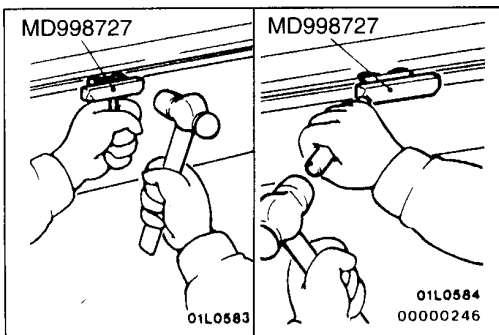

REMOVAL SERVICE POINT

◀▶ OIL PAN REMOVAL

After removing the oil pan mounting bolts, remove the oil pan with the special tool and a brass bar.

Caution

Perform this slowly to avoid deformation of the oil pan flange.

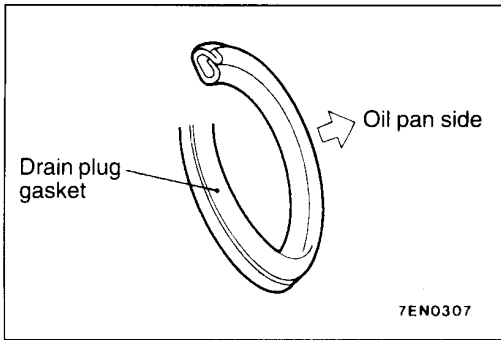

INSTALLATION SERVICE POINT

▶A◀ DRAIN PLUG GASKET INSTALLATION

Install the drain plug gasket in the direction so that it faces as shown in the illustration.

OIL PAN <DOHC>

11200280078

REMOVAL AND INSTALLATION

Pre-removal and Post-installation Operation

- Engine Oil Draining and Supplying (Refer to GROUP 12 – On-vehicle Service.)
- Oil Level Gauge Removal and Installation
- Centermember Assembly Removal and Installation (Refer to GROUP 32.)
- Under Cover Removal and Installation

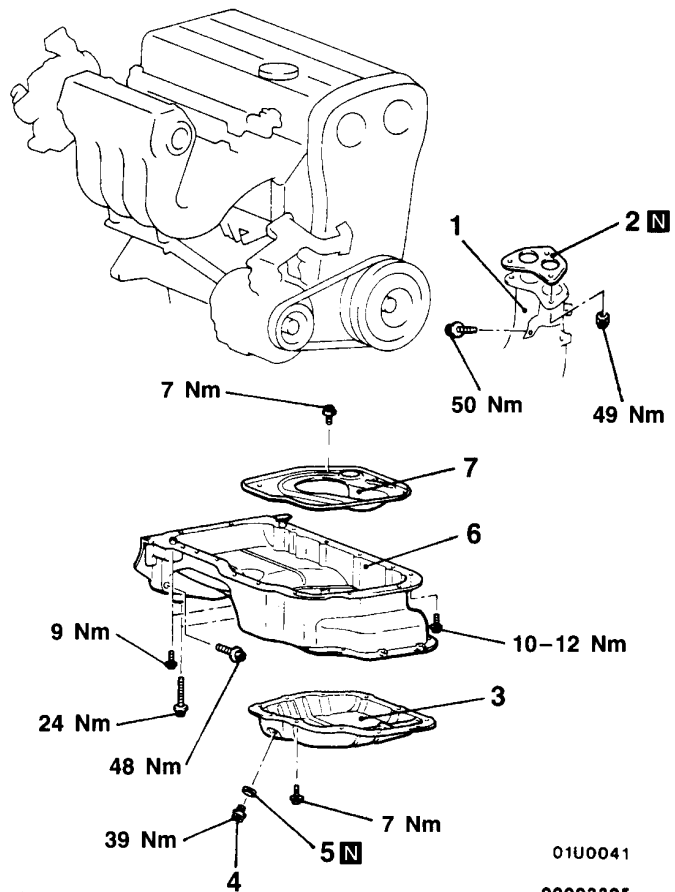
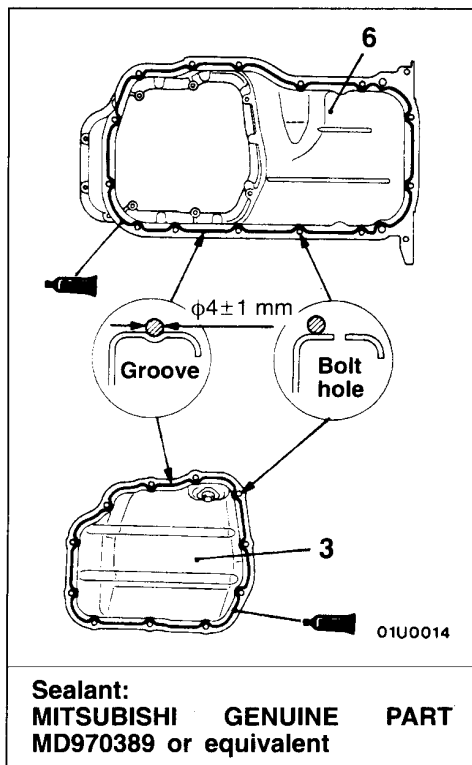

Removal steps

1. Front exhaust pipe connection
2. Gasket
3. Oil pan lower
4. Drain plug

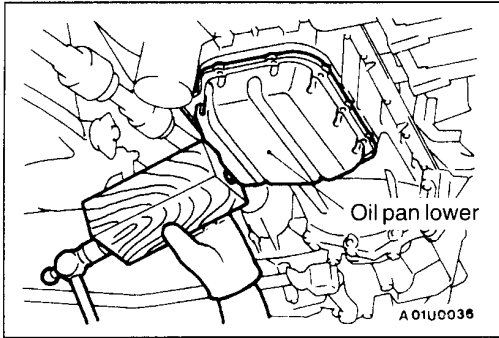

- ▶A◀ 5. Drain plug gasket
 ▶B▶ 6. Oil pan upper
 7. Baffle plate

**REMOVAL SERVICE POINTS****◀A▶ OIL PAN LOWER REMOVAL**

Place a piece of wood against the oil pan lower, and tap the piece of wood with a hammer to remove the oil pan lower.

Caution

Do not use the oil pan remover (MD998727) to remove the oil pan lower.

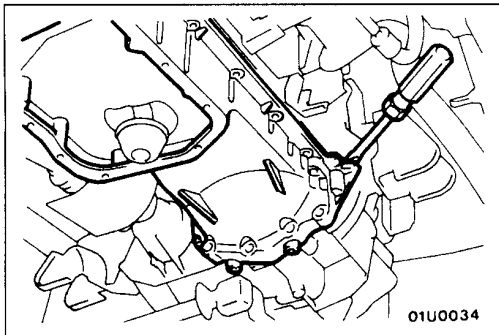
**◀B▶ OIL PAN UPPER REMOVAL**

Insert a flat-tipped screwdriver into the notch of the upper oil pan as shown in the illustration, and turn it to remove the oil pan.

Caution

Do not use the oil pan remover (MD998727) to remove the oil pan upper.

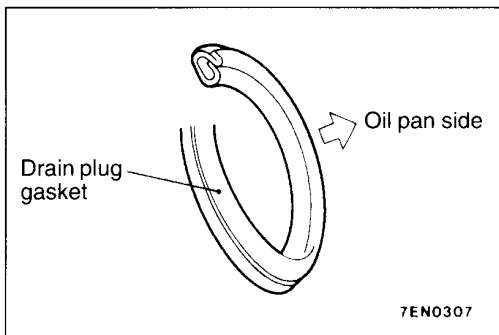
**INSTALLATION SERVICE POINTS****▶A◀ DRAIN PLUG GASKET INSTALLATION**

Install the drain plug gasket in the direction so that it faces as shown in the illustration.

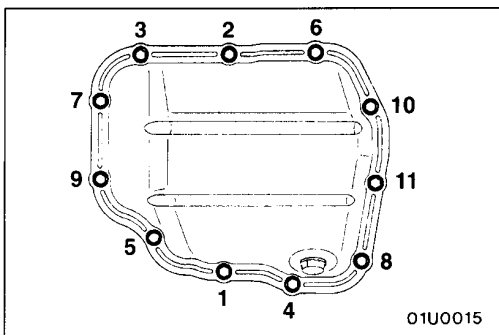
**▶B◀ OIL PAN LOWER INSTALLATION**

After applying the specified sealant, tighten the bolts in the order shown in the illustration.

Specified sealant:

MITSUBISHI GENUINE PART MD970389 or equivalent

**CRANKSHAFT OIL SEAL
REMOVAL AND INSTALLATION**

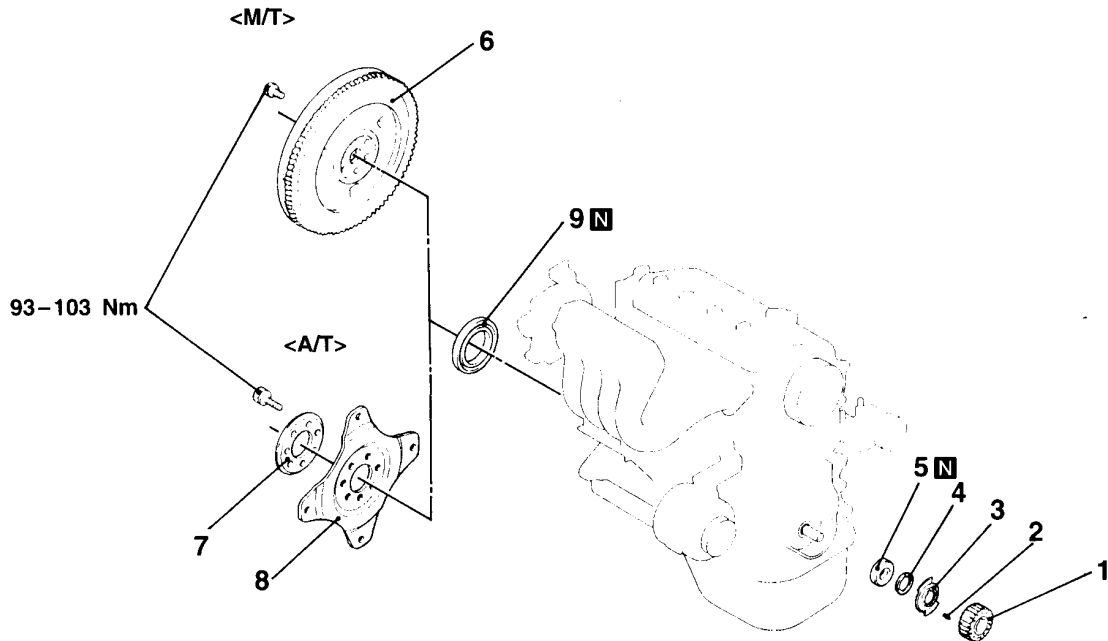

01U0018

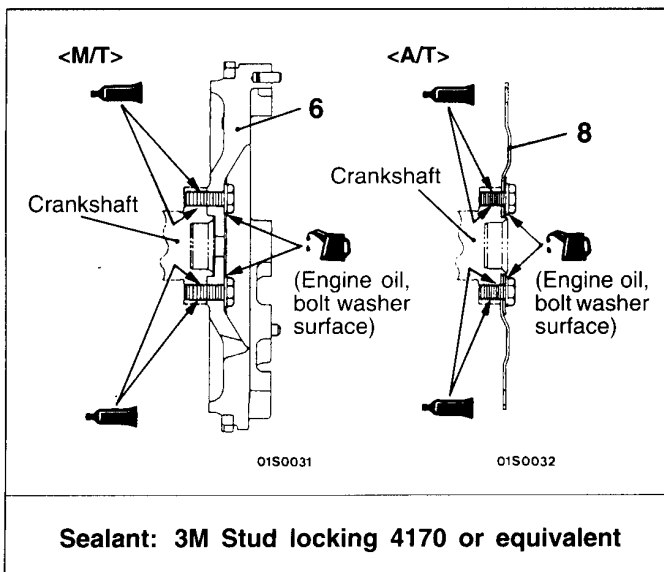

Sealant: 3M Stud locking 4170 or equivalent

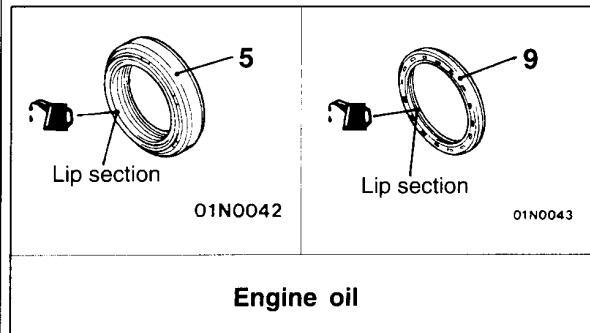

Engine oil

00003396

Crankshaft front oil seal removal steps

- Timing belt (SOHC: Refer to P.11-40.) (DOHC: Refer to P.11-43.)
- Crank angle sensor <DOHC> (Refer to GROUP 16.)
- 1. Crankshaft sprocket
- 2. Key
- 3. Crankshaft sensing blade <DOHC>
- 4. Crankshaft spacer <DOHC>
- 5. Crankshaft front oil seal



Crankshaft rear oil seal removal steps

- Oil pan (SOHC: Refer to P.11-25.) (DOHC: Refer to P.11-26.)
- Transmission assembly (M/T: Refer to GROUP 22.) (A/T: Refer to GROUP 23.)
- Clutch cover and disc <M/T>
- 6. Flywheel assembly <A/T>
- 7. Adapter plate <A/T>
- 8. Drive plate <A/T>
- 9. Crankshaft rear oil seal

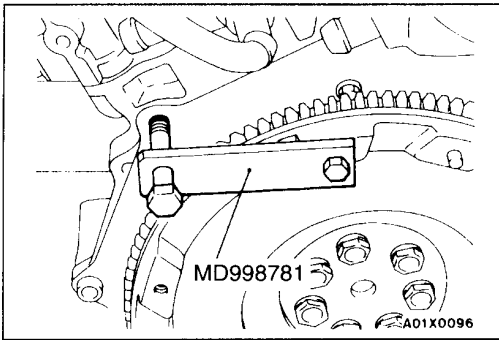

**REMOVAL SERVICE POINT****►A◄ FLYWHEEL ASSEMBLY <M/T>/ADAPTOR PLATE <A/T>/DRIVE PLATE <A/T> REMOVAL**

Use the special tool to secure the flywheel or drive plate, and remove the bolts.

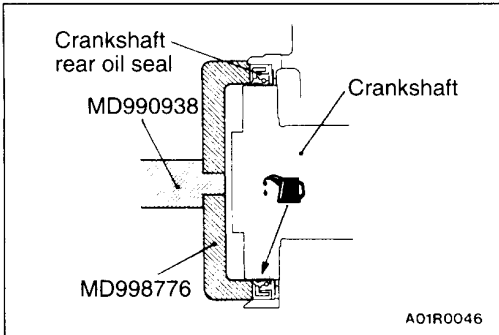
**INSTALLATION SERVICE POINTS****►A◄ CRANKSHAFT REAR OIL SEAL INSTALLATION**

1. Apply a small amount of engine oil to the entire circumference of the oil seal lip.
2. Install the oil seal by tapping it as far as the chamfered position of the oil seal case as shown in the illustration.

►B◄ FLYWHEEL ASSEMBLY <M/T>/ADAPTOR PLATE <A/T>/DRIVE PLATE <A/T> INSTALLATION

1. Clean off all sealant, oil and other substances which are adhering to the threaded bolts, crankshaft thread holes and the flywheel <M/T> or drive plate <A/T>.
2. Apply oil to the bearing surface of the flywheel <M/T> or drive plate <A/T> bolts.
3. Apply oil to the crankshaft thread holes.
4. Apply sealant to the threaded mounting holes.

Specified sealant: 3M Stud locking 4170 or equivalent

5. Use the special tool to secure the flywheel <M/T> or drive plate <A/T>, and then tighten the bolts to the specified torque.

Specified torque: 93–103 Nm

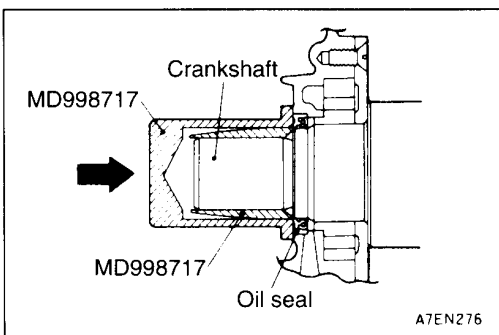
**►C◄ CRANKSHAFT FRONT OIL SEAL INSTALLATION**

1. Apply a small amount of engine oil to the entire circumference of the oil seal lip.
2. Tap the oil seal unit it is flush with the oil seal case.

CYLINDER HEAD GASKET <SOHC>

11200400085

REMOVAL AND INSTALLATION

Pre-removal Operation

- Fuel Line Pressure Releasing
(Refer to GROUP 13A – On-vehicle Service.)
- Engine Coolant Draining
(Refer to GROUP 14 – On-vehicle Service.)
- Air Intake Hose Removal
- Timing Belt Removal (Refer to P.11-40.)

Post-Installation Operation

- Timing Belt Installation (Refer to P.11-40.)
- Air Intake Hose Installation
- Engine Coolant Refilling
(Refer to GROUP 14 – On-vehicle Service.)
- Accelerator Cable Adjustment
(Refer to GROUP 13F – On-vehicle Service.)

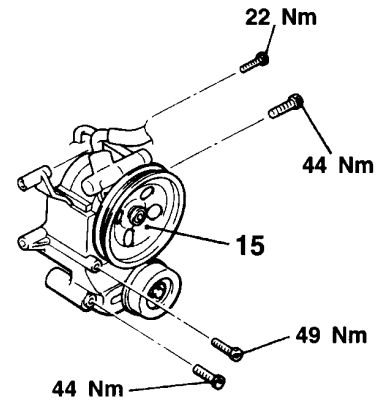
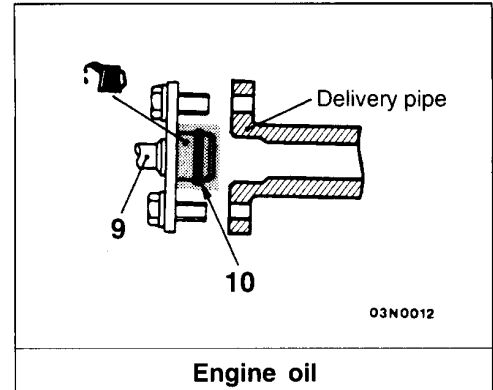
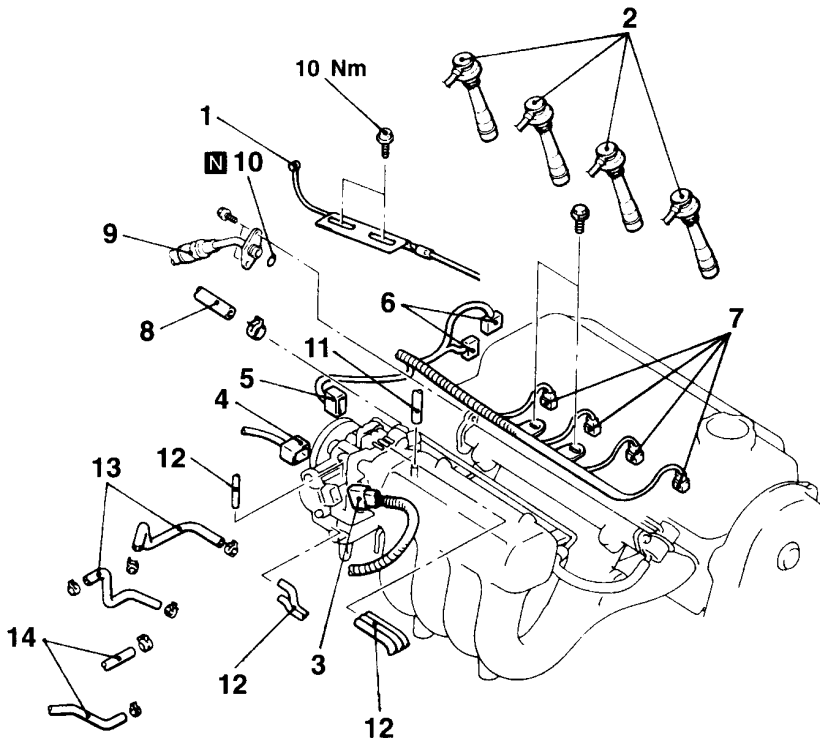

00003397

Removal steps

1. Accelerator cable connection
2. Spark plug cable
3. TPS connector
4. Idle speed control servo connector
5. Accelerator pedal position sensor connector <vehicles with TCL>
6. Distributor connector
7. Injector connector
8. Fuel return hose connection

- ▶E◀
9. Fuel high pressure hose connection
 10. O-ring
 11. Brake booster vacuum hose connection
 12. Vacuum hoses connection
 13. Water hoses connection
 14. Heater hoses connection
 15. Power steering oil pump and bracket assembly



<Cold engine>

74 Nm → 0 Nm → 20 Nm

→ +90° → +90°

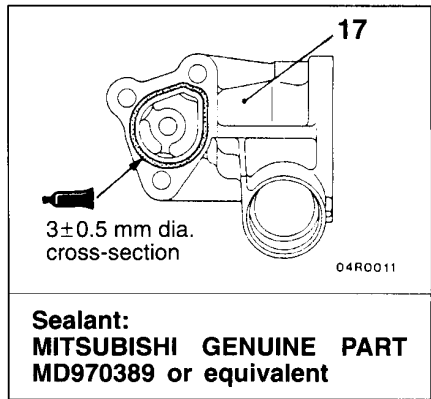
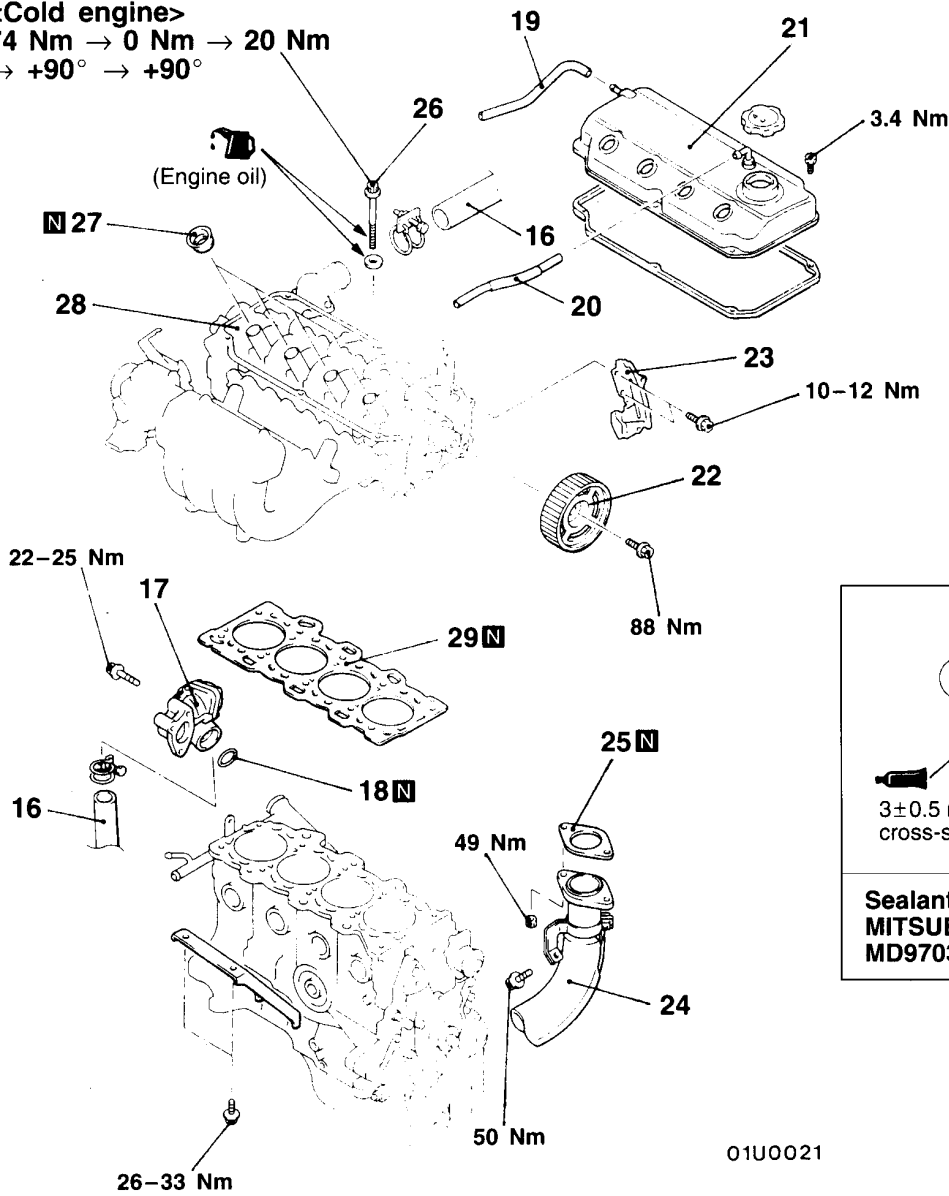

- 16. Radiator hose connection
- ▶D◀ 17. Water inlet fitting and thermostat case assembly
- 18. O-ring
- 19. Breather hose
- 20. PCV hose
- 21. Rocker cover
- ◀B▶ ▶C▶ 22. Camshaft sprocket

- 23. Timing belt rear cover
- 24. Front exhaust pipe connection
- 25. Gasket
- ◀C▶ ▶B▶ 26. Cylinder head bolt
- 27. Spark plug guide oil seal
- ▶A▶ 28. Cylinder head assembly
- ▶A▶ 29. Cylinder head gasket

REMOVAL SERVICE POINTS

◀A▶ POWER STEERING OIL PUMP AND BRACKET ASSEMBLY REMOVAL

Remove the power steering oil pump and bracket assembly from the engine with the hose attached.

NOTE

Place the removed power steering oil pump in a place where it will not be a hindrance when removing and installing the cylinder head assembly, and tie it with a cord.

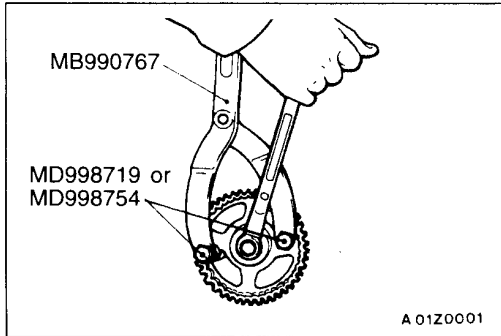

◀B▶ CAMSHAFT SPROCKET REMOVAL

◀C▶ CYLINDER HEAD BOLT REMOVAL

Loosen the bolts in 2 or 3 steps in order of the numbers shown in the illustration, and remove the cylinder head assembly.

Caution

Because the plug guides cannot be replaced by themselves, be careful not to damage or deform the plug guides when removing the cylinder head bolts.

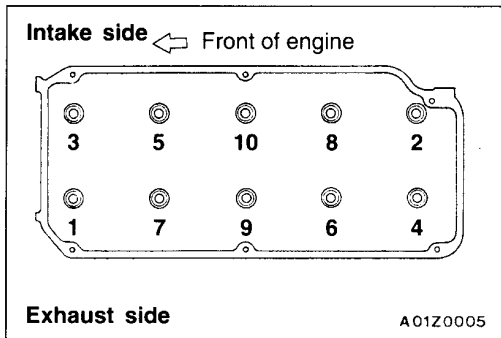

INSTALLATION SERVICE POINTS

▶A▶ CYLINDER HEAD GASKET INSTALLATION

1. Wipe off all oil and grease from the gasket mounting surface.
2. Install so that the shapes of the cylinder head holes match the shapes of the respective cylinder head gasket holes.

▶B▶ CYLINDER HEAD BOLT INSTALLATION

1. When installing the cylinder head bolts, the length below the head of the bolts should be within the limit. If it is outside the limit, replace the bolts.

Limit (A): 96.4 mm

2. The head bolt washer should be installed with the burred side caused by tapping out facing upwards.

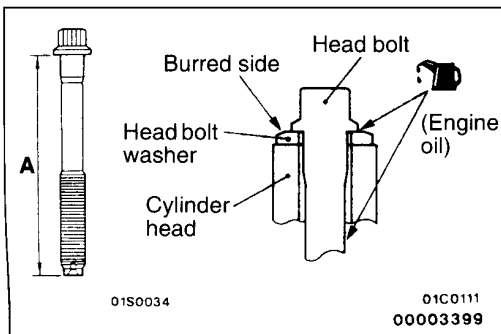

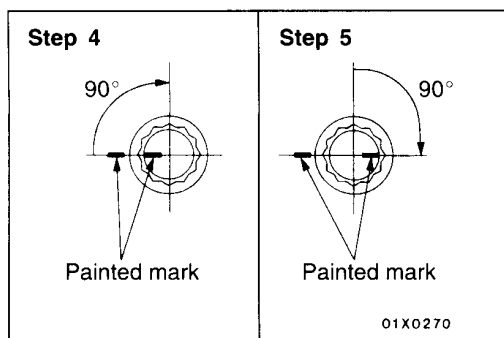
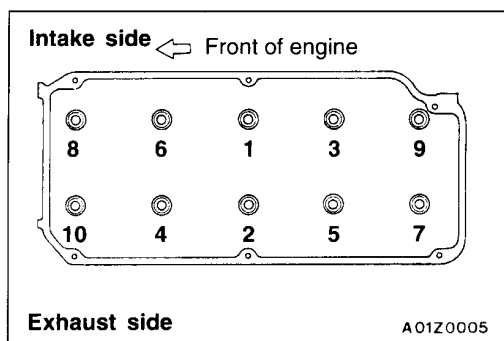

3. Apply a small amount of engine oil to the thread section and the washer of the cylinder head bolt.
4. Tighten the bolts by the following procedure.

Step	Operation	Remarks
1	Tighten to 78 Nm.	Carry out in the order shown in the illustration.
2	Fully loosen.	Carry out in the reverse order of that shown in the illustration.
3	Tighten to 20 Nm.	Carry out in the order shown in the illustration.
4	Tighten 90° of a turn.	In the order shown in the illustration. Mark the head of the cylinder head bolt and cylinder head by paint.
5	Tighten 90° of a turn.	In the order shown in the illustration. Check that the painted mark of the head bolt is lined up with that of the cylinder head.

Caution

1. Always make a tightening angle just 90°. If it is less than 90°, the head bolt will be loosened.
2. If it is more than 90°, remove the head bolt and repeat the procedure from step 1.

►◀ CAMSHAFT SPROCKET INSTALLATION

Use the special tool to stop the camshaft sprocket from turning in the same way as was done during removal, and then tighten the bolts to the specified torque.

Specified torque: 88 Nm

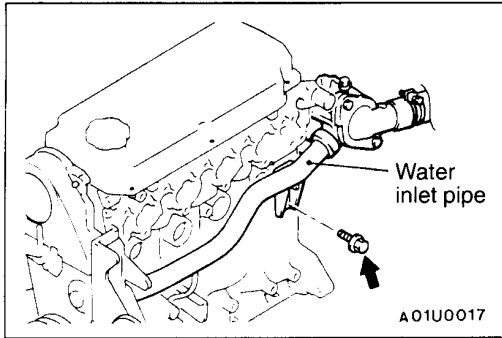

►D◄ WATER INLET FITTING AND THERMOSTAT CASE ASSEMBLY INSTALLATION

1. Loosen the waer inlet pipe bolt shown in the illustration.
2. Apply specified sealant to the thermostat case assembly in the specified places.

Specifed sealant:

MITSUBISHI GENUINE PART MD970389 or equivalent

3. Apply a small amount of water to the O-ring of the water inlet pipe, and then press thermostat case assembly into the water inlet pipe.
4. Tighten the thermostat case assembly mounting bolts.
5. Tighten the water inlet bolts.

►E◄ FUEL HIGH PRESSURE HOSE INSTALLATION

1. Apply a small amount of new engine oil to the O-ring.

Caution

- Do not let any engine oil get into the delivery pipe.

2. While turning the fuel high-pressure hose to the right and left, install the delivery pipe, while being careful not to damage the O-ring. After installing, check that the hose turns smoothly.
3. If the hose does not turn smoothly, the O-ring is probably being clamped. Disconnect the fuel high-pressure hose and check the O-ring for damage. After this, re-insert the delivery pipe and check that the hose turns smoothly.
4. Tighten to the specified torque.

CYLINDER HEAD GASKET <DOHC>

1120040092

REMOVAL AND INSTALLATION

Pre-removal Operation

- Fuel Line Pressure Releasing
(Refer to GROUP 13A – On-vehicle Service.)
- Engine Coolant Draining
(Refer to GROUP 14 – On-vehicle Service.)
- Air Intake Hose Removal
- Timing Belt Removal (Refer to P.11-43.)

Post-installation Operation

- Timing Belt Installation (Refer to P.11-43.)
- Air Intake Hose Installation
- Engine Coolant Refilling
(Refer to GROUP 14 – On-vehicle Service.)
- Accelerator Cable Adjustment
(Refer to GROUP 13F – On-vehicle Service.)

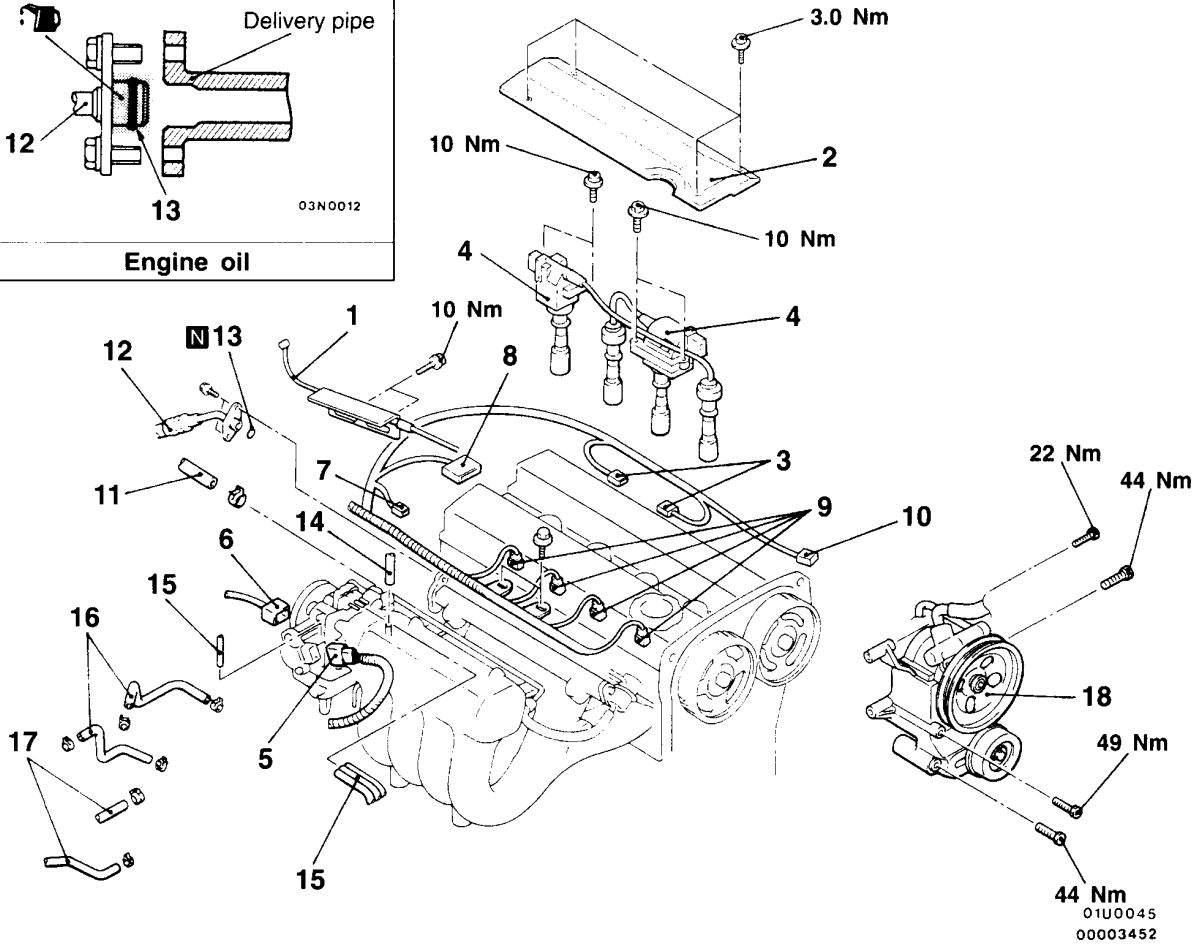
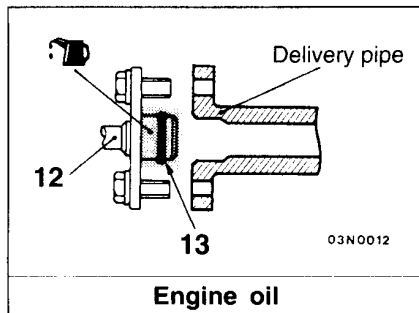

Removal steps

- | | |
|---|--|
| <ol style="list-style-type: none"> 1. Accelerator cable connection 2. Center cover 3. Ignition coil connector 4. Ignition coil assembly 5. TPS connector 6. Idle speed control servo connector 7. Oil presser switch connector 8. Ignition failure sensor connector 9. Injector connector 10. Cam position sensor connector | <p>▶E◀</p> <ol style="list-style-type: none"> 11. Fuel return hose connection 12. Fuel high pressure hose connection 13. O-ring 14. Brake booster vacuum hose connection 15. Vacuum hoses connection 16. Water hoses connection 17. Heater hoses connection 18. Power steering oil pump and bracket assembly |
|---|--|



<Cold engine>
 74 Nm → 0 Nm → 20 Nm
 → +90° → +90°

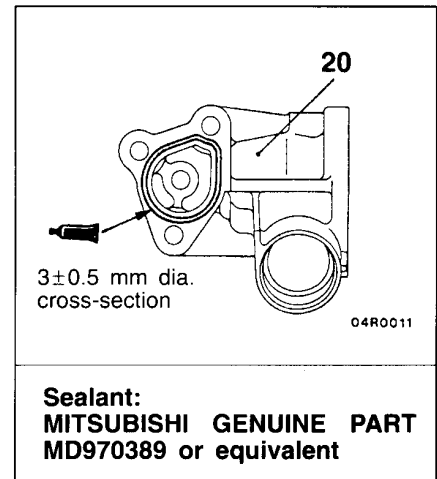
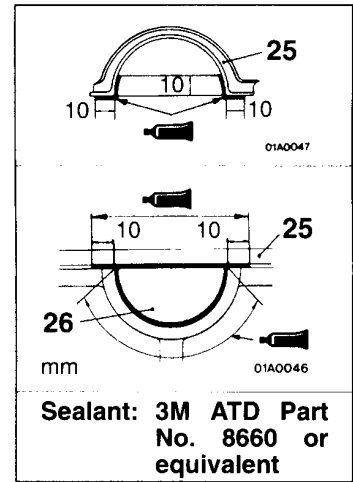
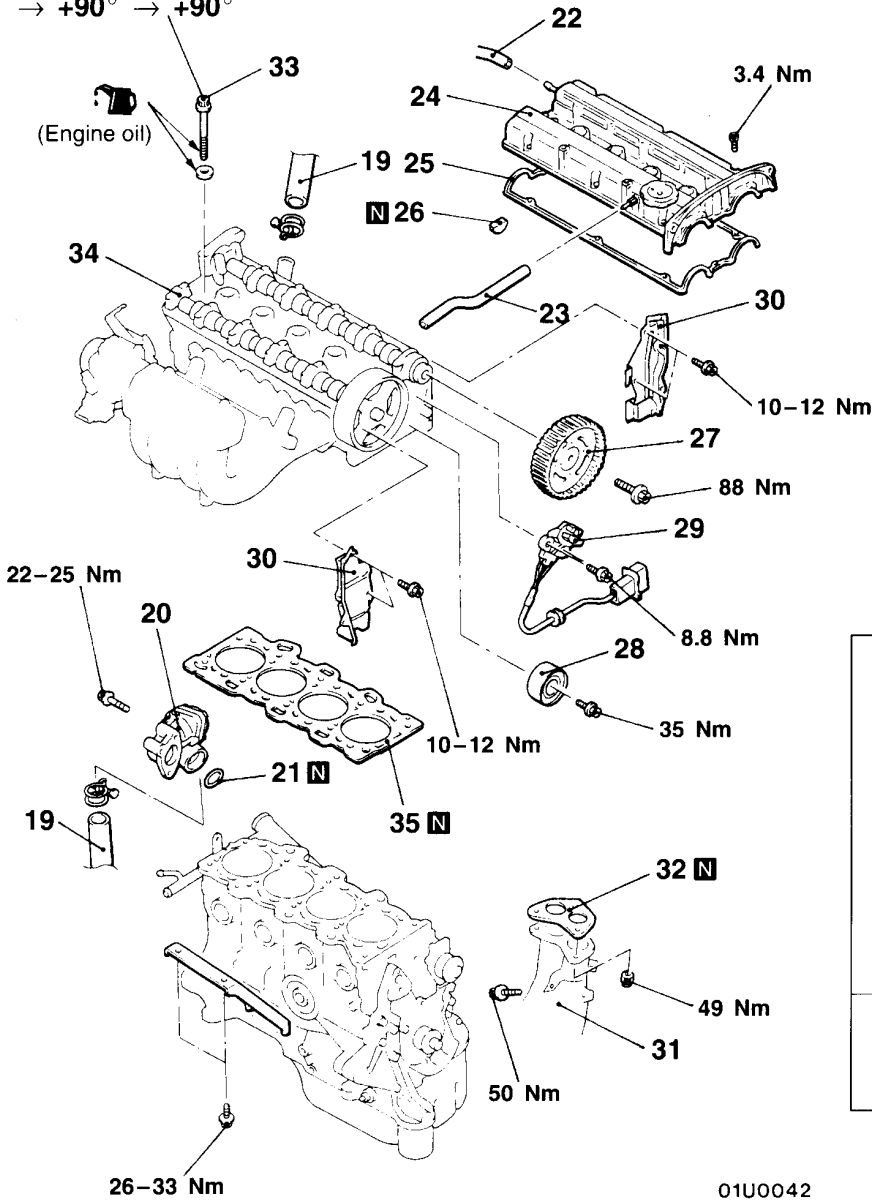

01U0042

00003453

- ▶D◀ 19. Radiator hose connection
- ▶D◀ 20. Water inlet fitting and thermostat case assembly
- 21. O-ring
- 22. Breather hose
- 23. PCV hose
- 24. Rocker cover
- 25. Rocker cover gasket
- 26. Semi-circular packing

- ◀B▶ ▶C◀ 27. Camshaft sprocket (exhaust side)
- 28. Idler pulley
- 29. Cam position sensor
- 30. Timing belt rear cover
- 31. Front exhaust pipe connection
- 32. Gasket
- ◀C▶ ▶B◀ 33. Cylinder head bolt
- 34. Cylinder head assembly
- ▶A◀ 35. Cylinder head gasket

REMOVAL SERVICE POINTS

◀A▶ POWER STEERING OIL PUMP AND BRACKET ASSEMBLY REMOVAL

Remove the power steering oil pump and bracket assembly from the engine with the hose attached.

NOTE

Place the removed power steering oil pump in a place where it will not be a hindrance when removing and installing the cylinder head assembly, and tie it with a cord.

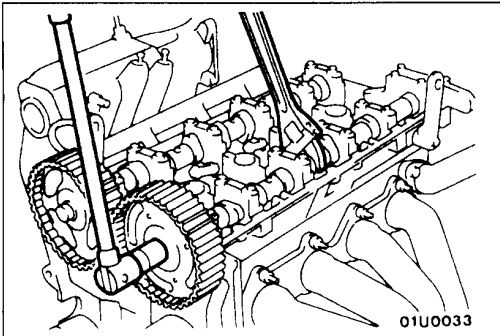

◀B▶ CAMSHAFT SPROCKET (EXHAUST SIDE) REMOVAL

Hold the hexagonal section of the camshaft with a wrench, etc., and loosen the camshaft sprocket bolt.

Caution

As the sprocket could become damaged, do not apply the wrench to the camshaft sprocket.

◀C▶ CYLINDER HEAD BOLT REMOVAL

Loosen the bolts in 2 or 3 steps in order of the numbers shown in the illustration, and remove the cylinder head assembly.

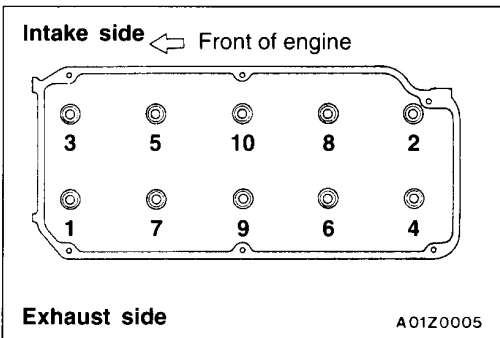

INSTALLATION SERVICE POINTS

▶A▶ CYLINDER HEAD GASKET INSTALLATION

1. Wipe off all oil and grease from the gasket mounting surface.
2. Install so that the shapes of the cylinder head holes match the shapes of the respective cylinder head gasket holes.

▶B▶ CYLINDER HEAD BOLT INSTALLATION

1. When installing the cylinder head bolts, the length below the head of the bolts should be within the limit. If it is outside the limit, replace the bolts.

Limit (A): 96.4 mm

2. The head bolt washer should be installed with the burred side caused by tapping out facing upwards.

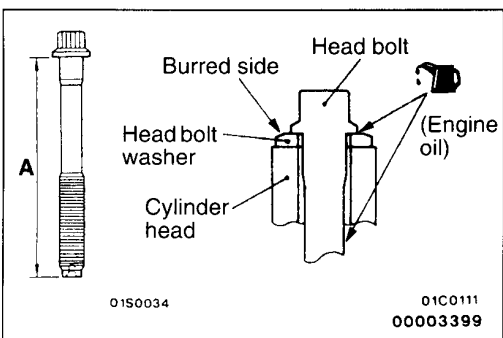

3. Apply a small amount of engine oil to the thread section and the washer of the cylinder head bolt.

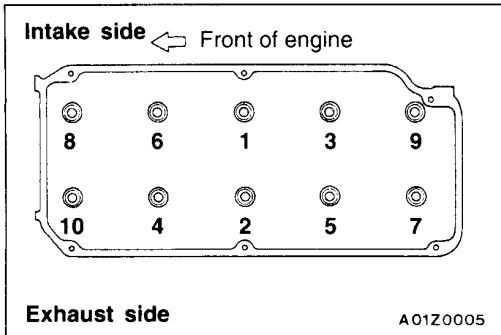

4. Tighten the bolts by the following procedure.

Step	Operation	Remarks
1	Tighten to 78 Nm.	Carry out in the order shown in the illustration.
2	Fully loosen.	Carry out in the reverse order of that shown in the illustration.
3	Tighten to 20 Nm.	Carry out in the order shown in the illustration.
4	Tighten 90° of a turn.	In the order shown in the illustration. Mark the head of the cylinder head bolt and cylinder head by paint.
5	Tighten 90° of a turn.	In the order shown in the illustration. Check that the painted mark of the head bolt is lined up with that of the cylinder head.

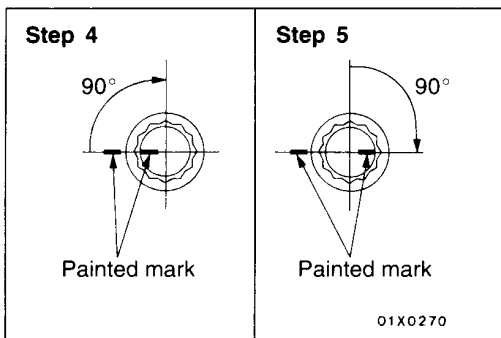

Caution

1. Always make a tightening angle just 90°. If it is less than 90°, the head bolt will be loosened.
2. If it is more than 90°, remove the head bolt and repeat the procedure from step 1.

►◀CAMSHAFT SPROCKET (EXHAUST SIDE) INSTALLATION

Use the special tool to stop the camshaft sprocket from turning in the same way as was done during removal, and then tighten the bolts to the specified torque.

Specified torque: 88 Nm

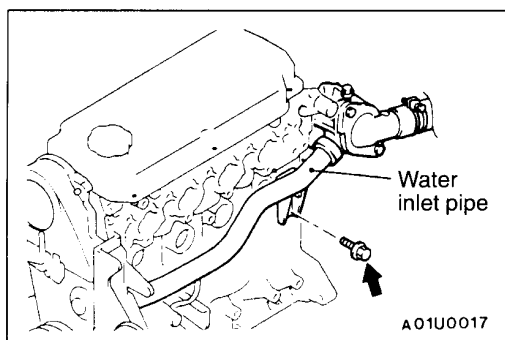
**►D◄ WATER INLET FITTING AND THERMOSTAT CASE ASSEMBLY INSTALLATION**

1. Loosen the waer inlet pipe bolt shown in the illustration.
2. Apply specified sealant to the thermostat case assembly in the specified places.

Specified sealant:

mitsubishi GENUINE PART MD970389 or equivalent

3. Apply a small amount of water to the O-ring of the water inlet pipe, and then press thermostat case assembly into the water inlet pipe.
4. Tighten the thermostat case assembly mounting bolts.
5. Tighten the water inlet pipe bolts.

►E◄ FUEL HIGH PRESSURE HOSE INSTALLATION

1. Apply a small amount of new engine oil to the O-ring.

Caution

- **Do not let any engine oil get into the delivery pipe.**

2. While turning the fuel high-pressure hose to the right and left, install the delivery pipe, while being careful not to damage the O-ring. After installing, check that the hose turns smoothly.
3. If the hose does not turn smoothly, the O-ring is probably being clamped. Disconnect the fuel high-pressure hose and check the O-ring for damage. After this, re-insert the delivery pipe and check that the hose turns smoothly.
4. Tighten to the specified torque.

TIMING BELT <SOHC>

REMOVAL AND INSTALLATION

Pre-removal and Post-installation Operation

- Under Cover (L.H.) Removal and Installation
- Engine Mount Bracket Removal and Installation (Refer to GROUP 32.)
- Crankshaft Pulley Removal and Installation (Refer to P.11-19.)

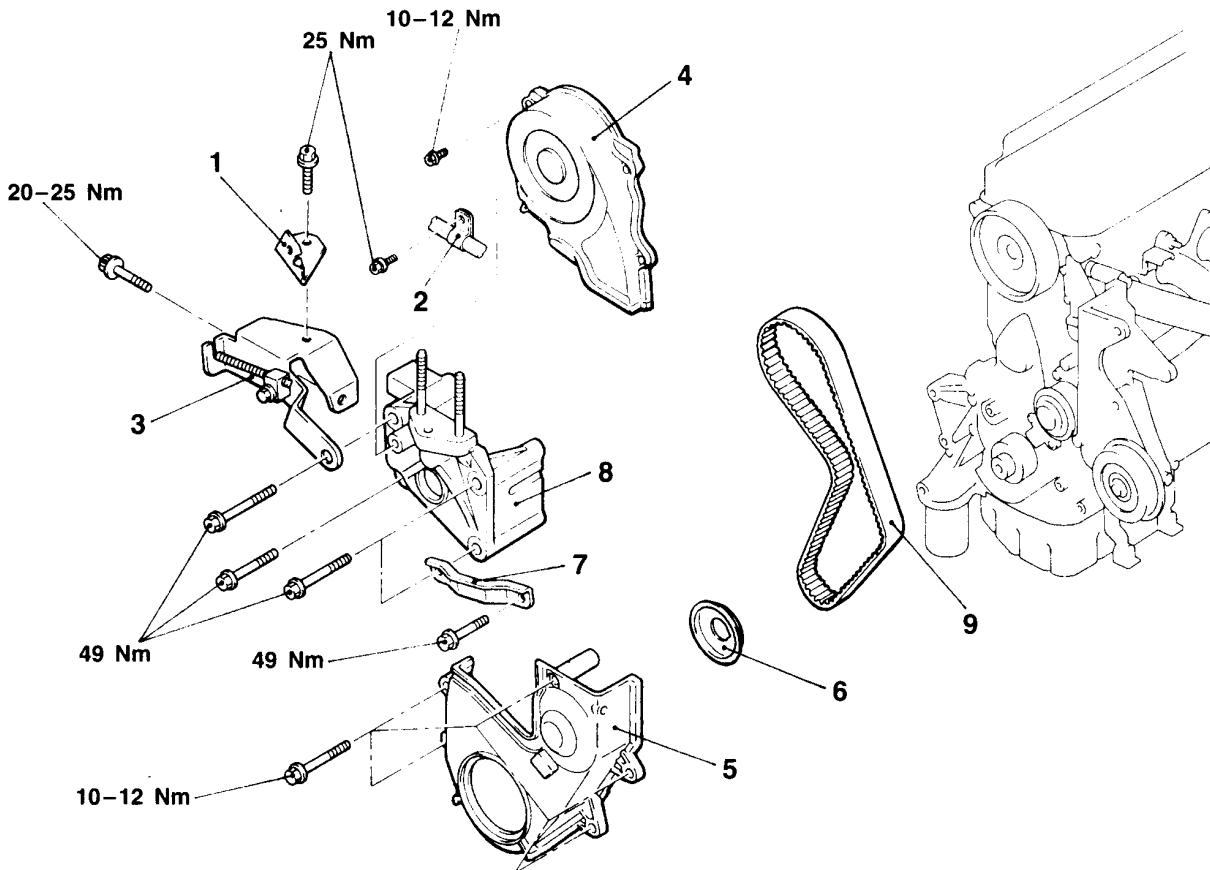

A01U0037

Removal steps

1. Power steering pressure hose bracket
2. Power steering pressure hose clip
3. Alternator brace
4. Timing belt upper cover
5. Timing belt lower cover
6. Flange
7. Power steering pump bracket stay
8. Engine support bracket
- Timing belt tension adjustment
9. Timing belt

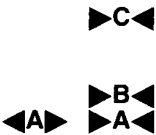

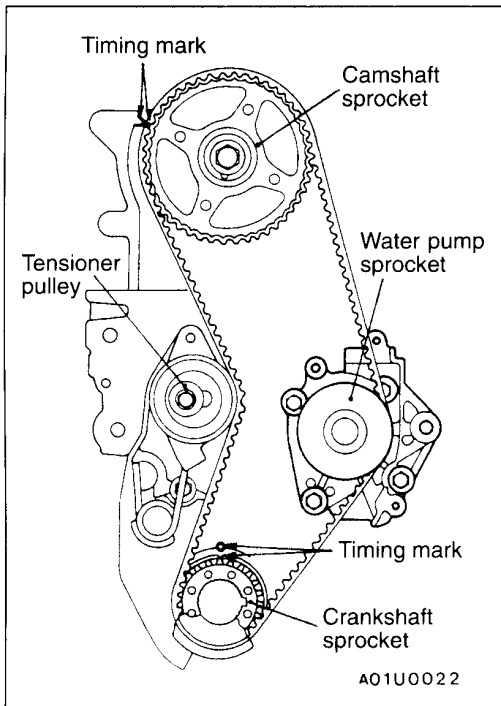
**REMOVAL SERVICE POINT****◀▶ TIMING BELT REMOVAL**

1. Turn the crankshaft clockwise (right turn) to align each timing mark and to set the No. 1 cylinder at compression top dead centre.

Caution

The crankshaft should always be turned only clockwise.

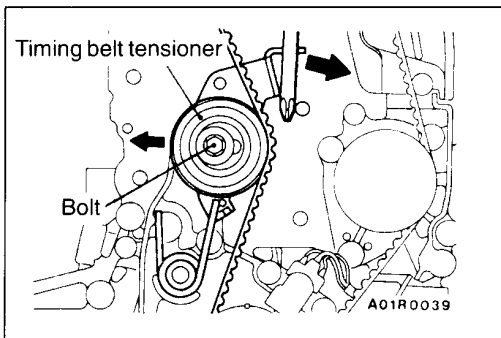

2. Loosen the timing belt tensioner bolt.
3. Set a screwdriver to the timing belt tensioner and press it fully back in the direction of the arrow.
4. Provisionally tighten the timing belt tensioner bolt.
5. Remove the timing belt.

Caution

If the timing belt is to be re-used, use chalk to mark the flat side of the belt with an arrow indicating the direction of rotation (right turn).

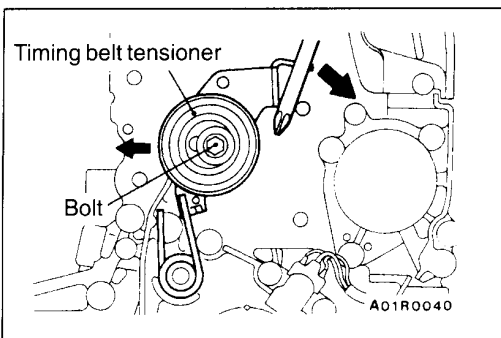
**INSTALLATION SERVICE POINTS****▶◀ TIMING BELT INSTALLATION**

1. With the timing belt tensioner bolt loosened, use a screwdriver to fully turn the timing belt tensioner as close to the engine mount as possible, and then provisionally tighten the tensioner bolt.
2. Align each of the camshaft sprocket and the crankshaft sprocket timing marks.
3. Install the timing belt in the following order, while making sure that the tension side of the belt is not slackened.
 - (1) Crankshaft sprocket
 - (2) Water pump sprocket
 - (3) Camshaft sprocket
 - (4) Tensioner pulley

Caution

After installing the timing belt, apply force to turn the camshaft sprocket in the reverse direction, and recheck to be sure that the belt is fully tensioned and that each timing mark is in the proper position.

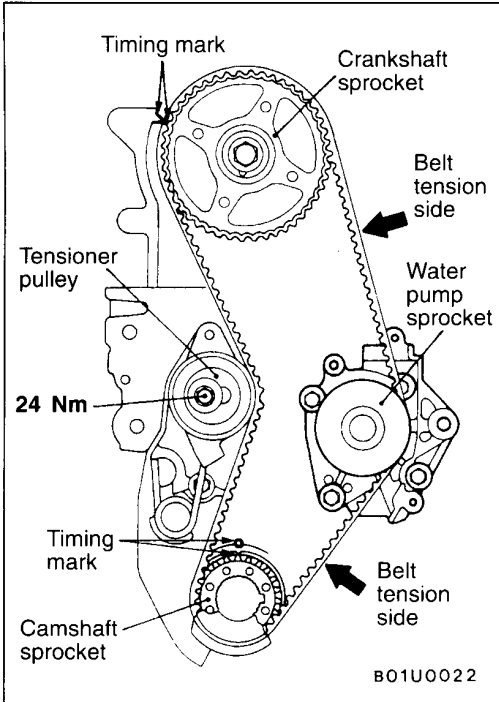

▶B◀TIMING BELT TENSION ADJUSTMENT

1. Initially loosen the fixing bolt of the tensioner pulley fixed to the engine mount side by 1/2-1/4 turn, and use the force of the tensioner spring to apply tension to the belt.
2. Turn the crankshaft in the proper rotation direction (right turn) for two rotations, and recheck to be sure that the timing marks on each sprocket are aligned.

Caution

As the purpose of this procedure is to apply the proper amount of tension to the tension side of the timing belt by using the cam driving torque, turn the crankshaft only by the amount given above. Be sure not to turn the crankshaft in the opposite direction (left turn).

3. After checking to be sure that no belt teeth in the section marked with A are lifted up and that the teeth in each sprocket are engaged, secure the tensioner pulley.

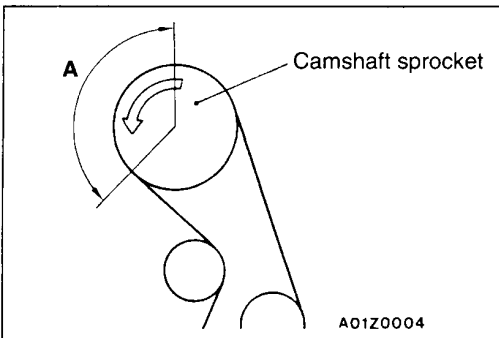

▶C◀FLANGE INSTALLATION

Install the flange as shown in the illustration.

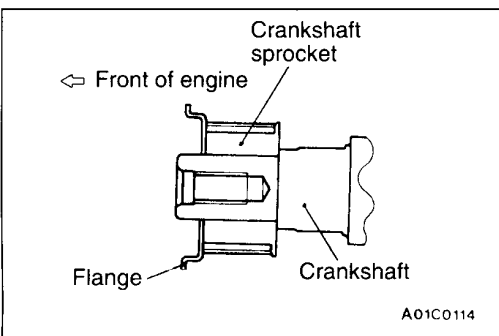

TIMING BELT <DOHC>

11200430091

REMOVAL AND INSTALLATION

Pre-removal and Post-installation Operation

- Under Cover (L.H.) Removal and Installation
- Engine Mount Bracket Removal and Installation (Refer to GROUP 32.)
- Crankshaft Pulley Removal and Installation (Refer to P.11-19.)

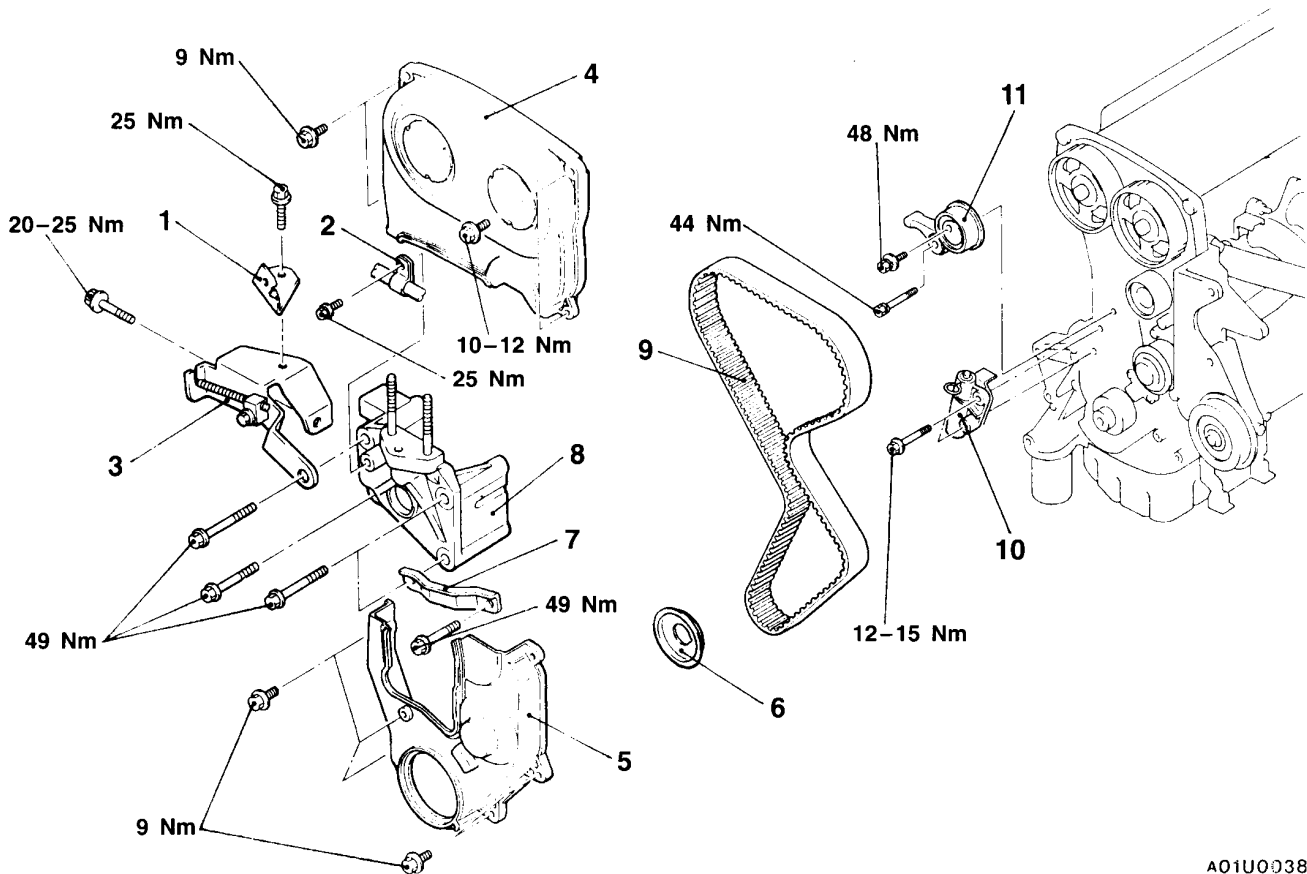

A01U0038

Removal steps

1. Power steering pressure hose bracket
2. Power steering pressure hose clip
3. Alternator brace
4. Timing belt upper cover
5. Timing belt lower cover
6. Flange
7. Power steering pump bracket stay
8. Engine support bracket
9. Timing belt
10. Auto tensioner
11. Tension pulley and arm assembly

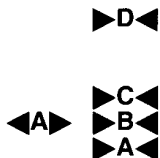

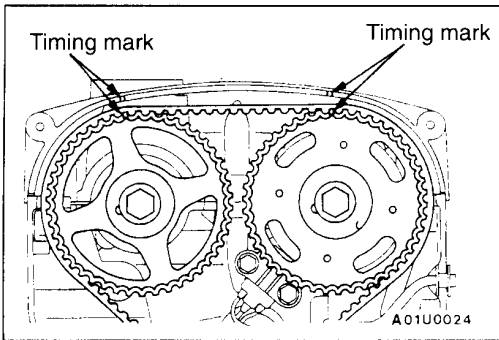

REMOVAL SERVICE POINT

◀A▶ TIMING BELT REMOVAL

1. Turn the crankshaft clockwise to align each timing mark.

Caution

The crankshaft must always be turned clockwise.

2. Loosen the tensioner pulley center bolt and remove the timing belt.

Caution

If the timing belt is to be re-used, use chalk to mark (on its flat side) an arrow indicating the clockwise direction.

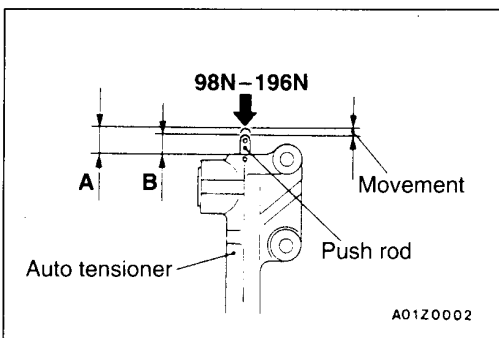

INSTALLATION SERVICE POINTS

▶A◀ AUTO TENSIONER INSTALLATION

1. Apply 98–196 N force to the push rod of the auto tensioner by pressing it against a metal (cylinder block, etc.), and measure the movement of the push rod.

Standard value:

Within 1 mm

A: Length when it is free (not pressed)

B: Length when it is pressed

A – B: Movement

2. If it is out of the standard value, change the auto tensioner.
3. Use a press or vice to gently compress the auto tensioner push rod until pin hole A of the push rod and pin hole B of the tensioner cylinder are aligned.

Caution

If the compression speed is too fast, the push rod may become damaged, so be sure to carry out this operation slowly.

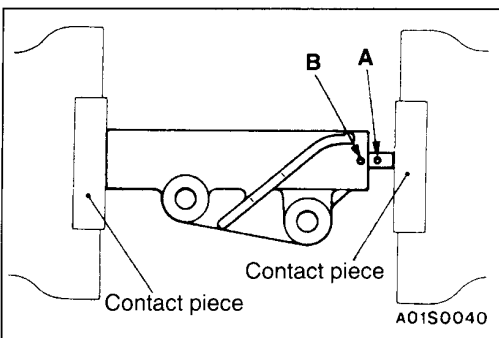

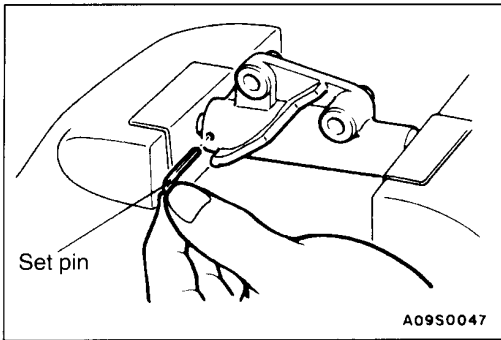

- Once the holes are aligned, insert the set pin.

NOTE

When replacing the auto tensioner with a new part, the pin will be in the auto tensioner.

- Install the auto tensioner to the engine.

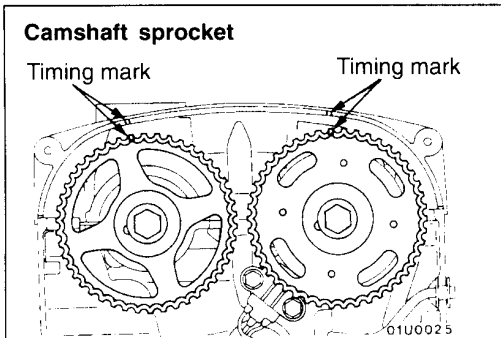

▶B◀TIMING BELT INSTALLATION

- Align the timing marks of each camshaft sprocket and the crankshaft sprocket.
- Loosen the tensioner pulley center bolt.
- Move the crankshaft sprocket half a tooth width in the anti-clockwise direction.

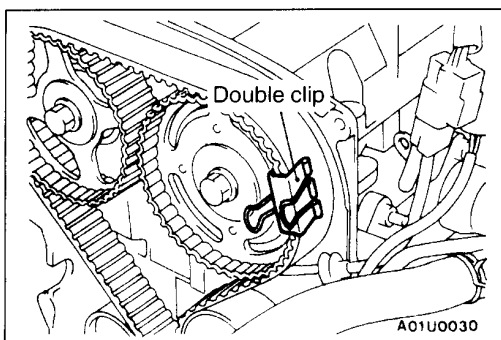
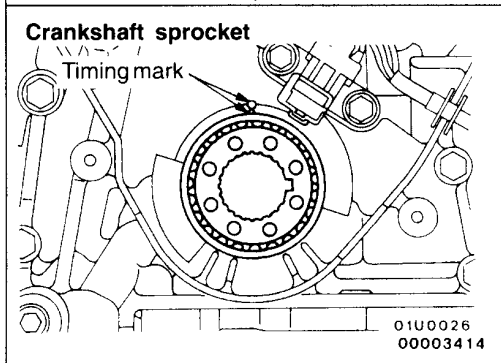

- Place the timing belt on the exhaust-side camshaft sprocket, and hold it in the position shown in the illustration with a double clip.

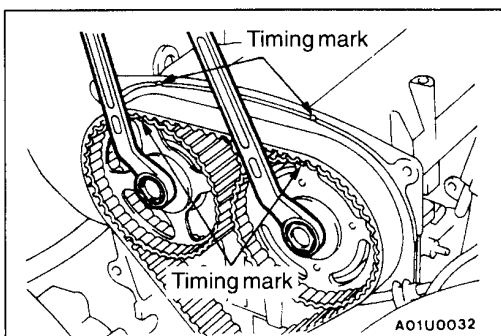

- Place the timing belt on the intake-side sprocket while using two wrenches to align the timing marks.

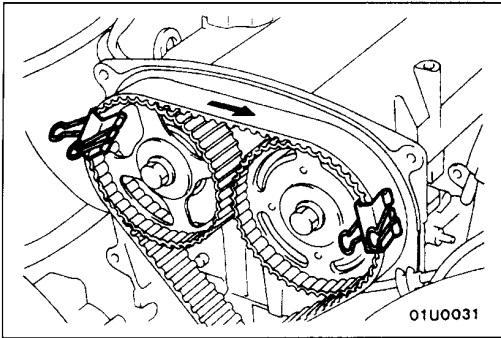

6. Hold the belt in the position shown in the illustration with another double clip.

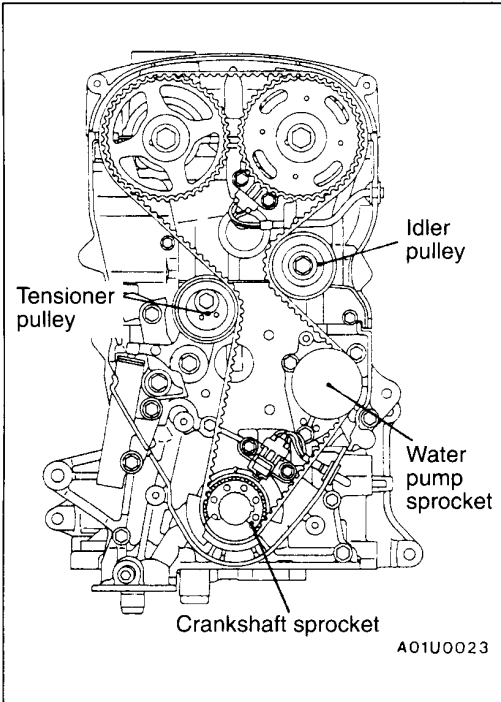

7. Place the belt onto the idler pulley, water pump sprocket, crankshaft sprocket and tensioner pulley in that order.
8. Remove the two double clips.

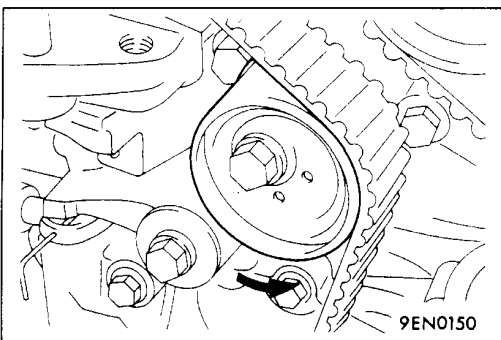

9. Lift the tensioner pulley in the direction of the arrow and tighten the tensioner pulley bolt.
10. Check to be sure that all timing marks are aligned.
11. Adjust the timing belt tension.

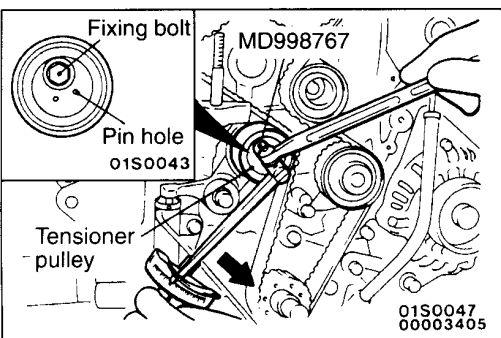

▶◀TIMING BELT TENSION ADJUSTMENT

1. After turning the crankshaft a 1/4 turn anti-clockwise, turn it clockwise to the position where the timing marks are aligned.
2. Loosen the fixing bolt of the tensioner pulley and using the special tool and a torque wrench, apply tension to the timing belt; then tighten the fixing bolt at the specified torque.

Standard Value:
2.5–4.0 Nm {timing belt tension torque (reference value)}

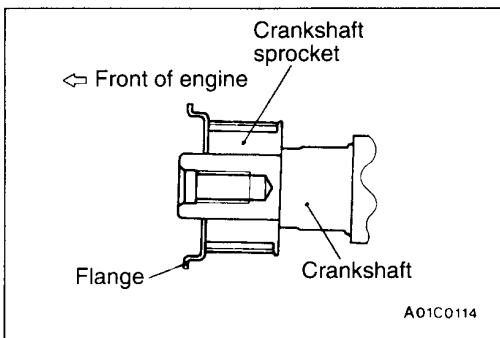
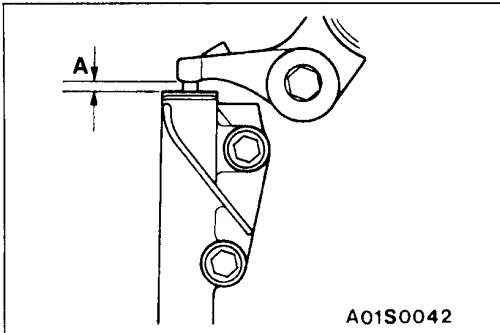
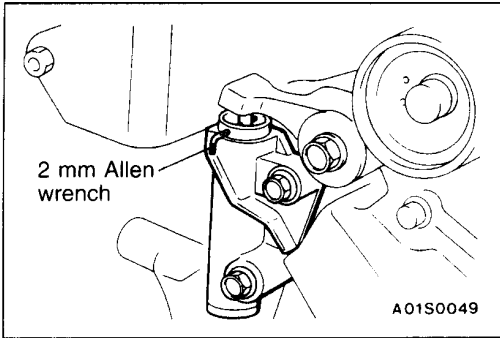
**Caution**

When tightening the fixing bolt, ensure that the tensioner pulley shaft doesn't rotate with the bolt.

3. Take out the 2 mm Allen wrench from the auto tensioner. At this time, check to be sure that 2 mm Allen wrench can be pulled out easily. Turn the crankshaft clockwise 2 turns, and after leaving it in this position for 5 minutes or more, check again to be sure that the auto tensioner 2 mm Allen wrench can be pulled out or inserted easily.

NOTE

Even if the 2 mm Allen wrench cannot be easily inserted, then it is satisfactory if the amount of protrusion of the auto tensioner rod is within the standard value.

Standard value (A): 3.8 – 4.5 mm

If it is outside the standard value, repeat the operations in steps 1 to 4.

4. Check to be sure that the timing marks on all sprockets are aligned.

►D◄ FLANGE INSTALLATION

Install the flange as shown in the illustration.

ENGINE ASSEMBLY <SOHC>

11200100084

REMOVAL AND INSTALLATION

Pre-removal Operations

- Fuel Line Pressure Releasing
(Refer to GROUP 13A – On-vehicle Service.)
- Hood Removal (Refer to GROUP 42.)
- Engine Coolant Draining
(Refer to GROUP 14 – On-vehicle Service.)
- Transmission Assembly Removal
(M/T: Refer to GROUP 22.)
(A/T: Refer to GROUP 23.)
- Radiator Assembly Removal (Refer to GROUP 14.)

Post-installation Operations

- Radiator Assembly Installation
(Refer to GROUP 14.)
- Transmission Assembly Installation
(M/T: Refer to GROUP 22.)
(A/T: Refer to GROUP 23.)
- Accelerator Cable Adjustment
(Refer to GROUP 13F – On-vehicle Service.)
- Engine Coolant Refilling
(Refer to GROUP 14 – On-vehicle Service.)
- Drive Belt Tension Adjustment (Refer to P.11-6.)
- Hood Installation (Refer to GROUP 42.)

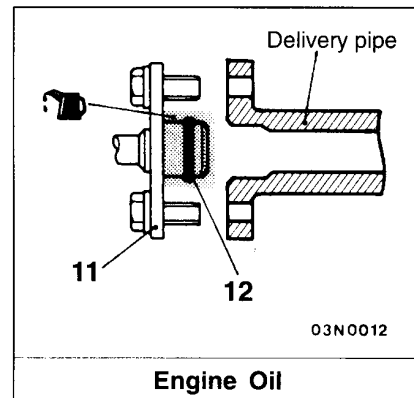
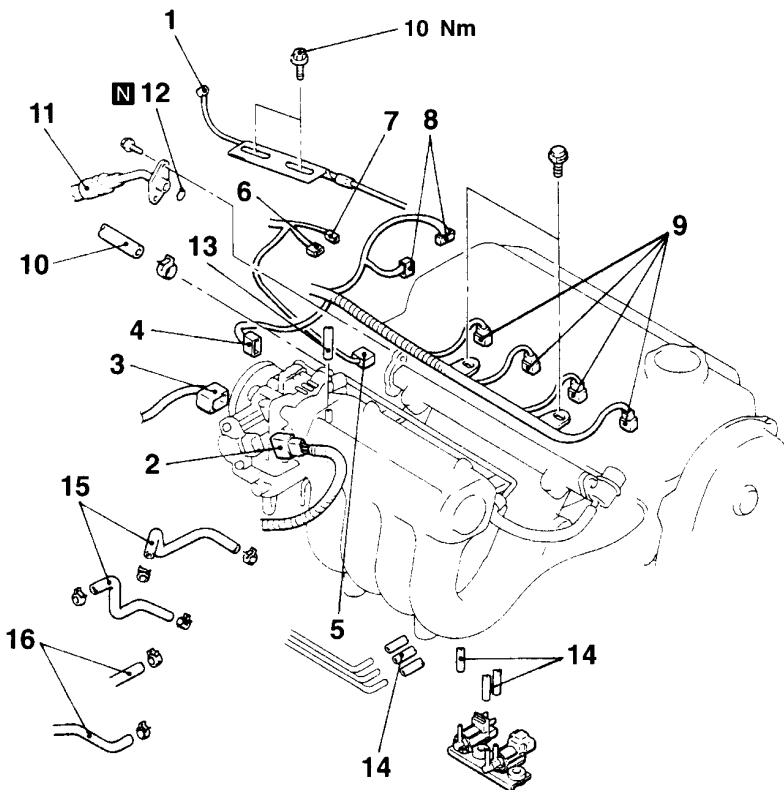

01U0029

00003445

Removal steps

- | | |
|--|---|
| <ol style="list-style-type: none"> 1. Accelerator cable connection 2. TPS connector 3. Idle speed control servo connector 4. Accelerator pedal position sensor connector <Vehicles with TCL> 5. Detonation sensor connector 6. Engine coolant temperature sensor connector 7. Engine coolant temperature gauge unit connector | <ol style="list-style-type: none"> 8. Distributor connector 9. Injector connector 10. Fuel return hose connection ▶◀ 11. Fuel high pressure hose connection 12. O-ring 13. Brake booster vacuum hose connection 14. Vacuum hoses connection 15. Water hoses connection 16. Heater hoses connection |
|--|---|

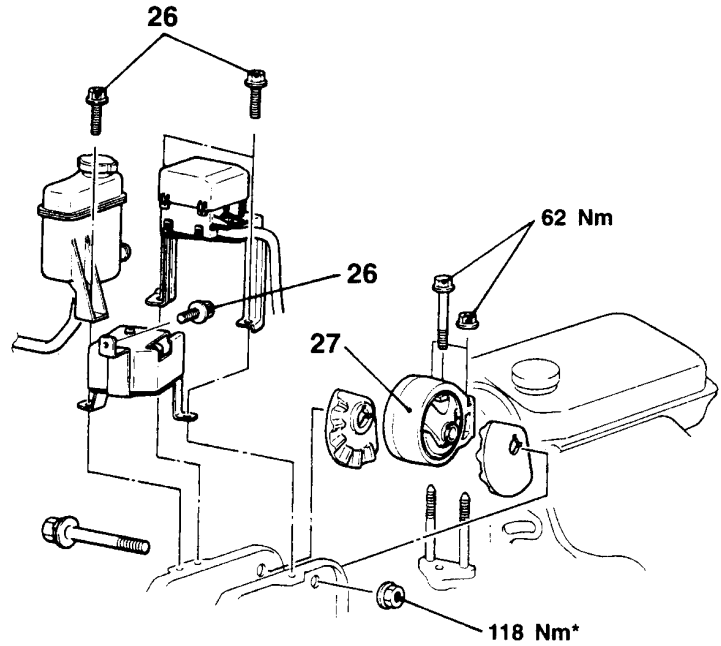

01U0007

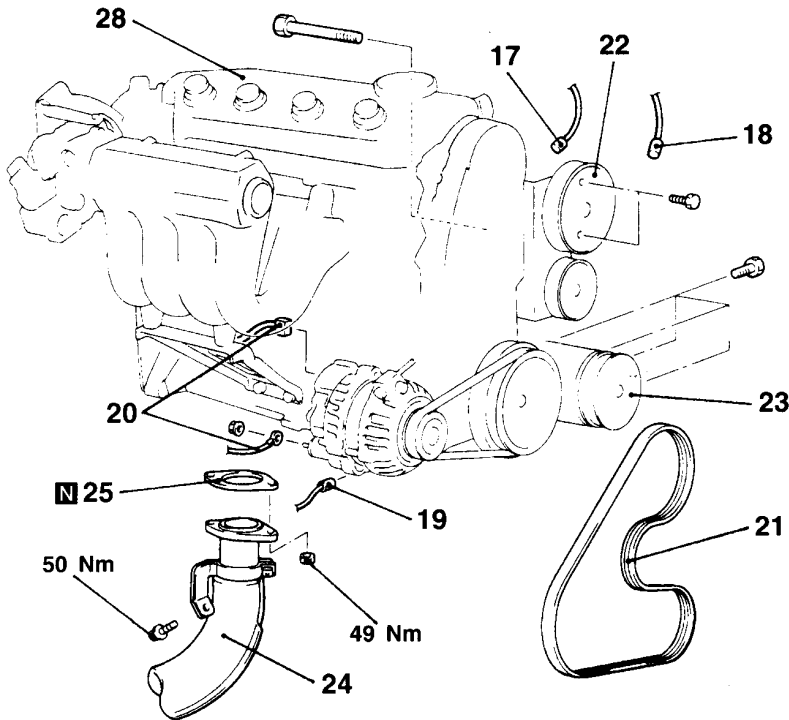

01U0027

00003446

- 17. Power steering oil pressure switch connector
- 18. A/C compressor connector
- 19. Oil pressure switch connector
- 20. Alternator connector
- 21. Drive belt (power steering, A/C)
- 22. Power steering oil pump connection
- 23. A/C compressor pipe connection
- 24. Front exhaust pipe connection
- 25. Gasket

- 26. Bolts
- 27. Engine mount bracket
- 28. Engine assembly



Caution
 *: Indicates parts which should be temporarily tightened, and then fully tightened with the vehicle on the ground in the unladen condition.

REMOVAL SERVICE POINTS**◀A▶ POWER STEERING OIL PUMP REMOVAL**

Remove the power steering oil pump from the bracket with the hose attached.

NOTE

Place the removed power steering oil pump where it will not be a hindrance when removing and installing the engine assembly, and tie it with a cord.

◀B▶ A/C COMPRESSOR REMOVAL

Disconnect the A/C compressor connector and remove the compressor from the compressor bracket with the hose still attached.

NOTE

Place the removed A/C compressor where it will not be a hindrance when removing and installing the engine assembly, and tie it with a cord.

◀C▶ ENGINE MOUNT BRACKET REMOVAL

1. Support the engine with a garage jack.
2. Remove the mechanical hanger (recommended tool) which was attached when the transmission assembly was removed.
3. Hold the engine assembly with a chain block or similar tool.
4. Place a garage jack against the engine oil pan with a piece of wood in between, jack up the engine so that the weight of the engine is no longer being applied to the engine mount bracket, and then remove the engine mount bracket.

◀D▶ ENGINE ASSEMBLY REMOVAL

After checking that all cables, hoses and harness connectors, etc., are disconnected from the engine, lift the chain block slowly to remove the engine assembly upward from the engine compartment.

INSTALLATION SERVICE POINTS**▶A◀ ENGINE ASSEMBLY INSTALLATION**

Install the engine assembly, checking that the cables, hoses, and harness connectors are not clamped.

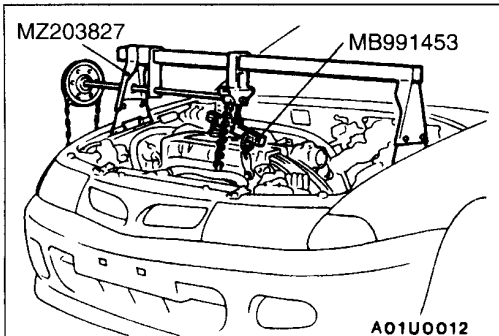
**▶B◀ ENGINE MOUNT BRACKET INSTALLATION**

1. Place a garage jack against the engine oil pan with a piece of wood in between, and install the engine mount bracket while adjusting the position of the engine.
2. Support the engine with the garage jack.
3. Remove the chain block and support the engine assembly with the mechanical hanger (recommended tool).

▶C◀ FUEL HIGH PRESSURE HOSE INSTALLATION

1. Apply a small amount of new engine oil to the O-ring.

Caution

- Do not let any engine oil get into the delivery pipe.

2. While turning the fuel high-pressure hose to the right and left, install the delivery pipe, while being careful not to damage the O-ring. After installing, check that the hose turns smoothly.
3. If the hose does not turn smoothly, the O-ring is probably being clamped. Disconnect the fuel high-pressure hose and check the O-ring for damage. After this, re-insert the delivery pipe and check that the hose turns smoothly.
4. Tighten to the specified torque.

ENGINE ASSEMBLY <DOHC>

11200100091

REMOVAL AND INSTALLATION

Pre-removal Operations

- Fuel Line Pressure Releasing
(Refer to GROUP 13A – On-vehicle Service.)
- Hood Removal (Refer to GROUP 42.)
- Engine Coolant Draining
(Refer to GROUP 14 – On-vehicle Service.)
- Transmission Assembly Removal
(Refer to GROUP 22.)
- Radiator Assembly Removal (Refer to GROUP 14.)

Post-installation Operations

- Radiator Assembly Installation
(Refer to GROUP 14.)
- Transmission Assembly Installation
(Refer to GROUP 22.)
- Accelerator Cable Adjustment
(Refer to GROUP 13F – On-vehicle Service.)
- Engine Coolant Refilling
(Refer to GROUP 14 – On-vehicle Service.)
- Drive Belt Tension Adjustment (Refer to P.11-6.)
- Hood Installation (Refer to GROUP 42.)

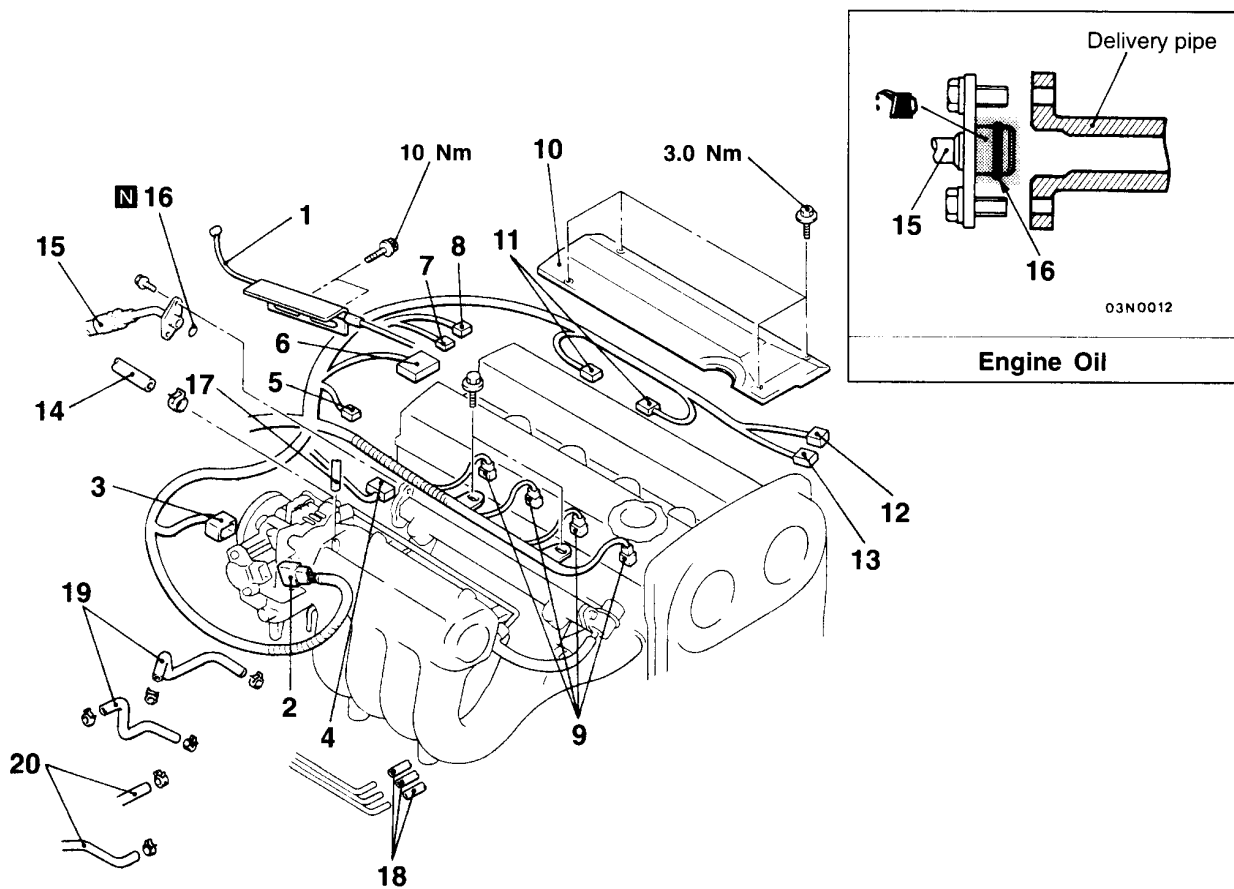

01U0044

00003466

Removal steps

1. Accelerator cable connection
2. TPS connector
3. Idle speed control servo connector
4. Detonation sensor connector
5. Oil presser switch connector
6. Ignition failure sensor connector
7. Engine coolant temperature sensor connector
8. Engine coolant temperature gauge unit connector
9. Injector connector

10. Center cover
11. Ignition coil connector
12. Cam position sensor connector
13. Crank angle sensor connector
14. Fuel return hose connection
15. Fuel high pressure hose connection
16. O-ring
17. Brake booster vacuum hose connection
18. Vacuum hoses connection
19. Water hoses connection
20. Heater hoses connection



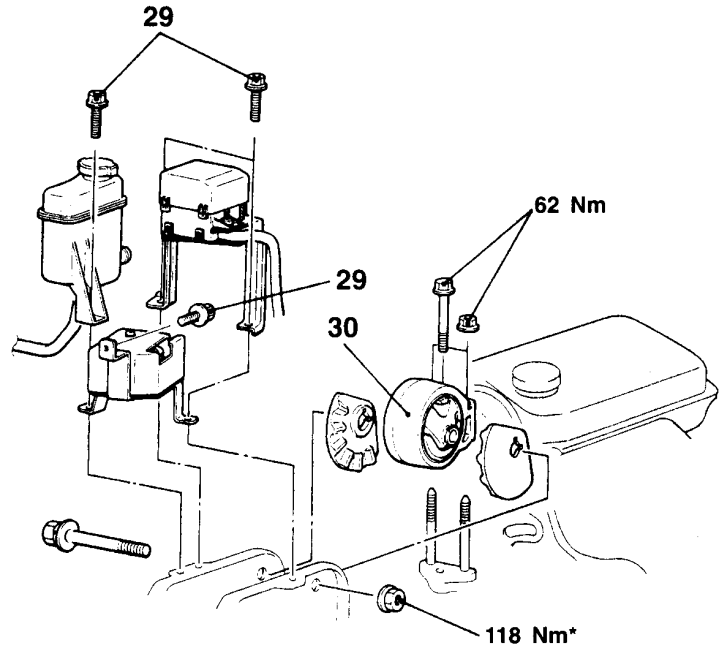

01U0007

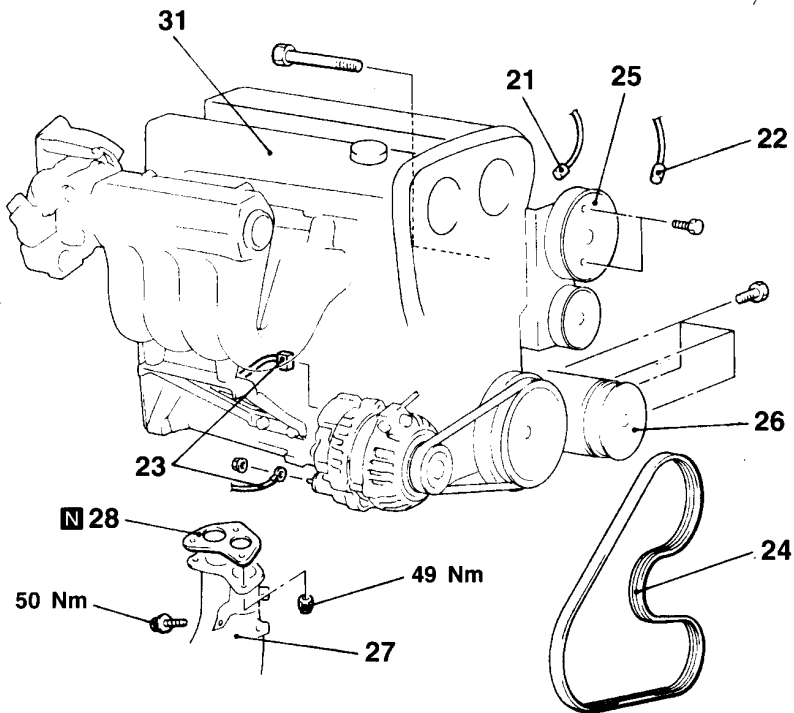

01U0043

00003467

- 21. Power steering oil pressure switch connector
- 22. A/C compressor connector
- 23. Alternator connector
- 24. Drive belt (power steering, A/C)
- 25. Power steering oil pump connection
- 26. A/C compressor connection
- 27. Front exhaust pipe connection
- 28. Gasket
- 29. Bolts

- C B 30. Engine mount bracket
- D A 31. Engine assembly



Caution

*: Indicates parts which should be temporarily tightened, and then fully tightened with the vehicle on the ground in the unladen condition.

REMOVAL SERVICE POINTS**◀A▶ POWER STEERING OIL PUMP REMOVAL**

Remove the power steering oil pump from the bracket with the hose attached.

NOTE

Place the removed power steering oil pump where it will not be a hindrance when removing and installing the engine assembly, and tie it with a cord.

◀B▶ A/C COMPRESSOR REMOVAL

Disconnect the A/C compressor connector and remove the compressor from the compressor bracket with the hose still attached.

NOTE

Place the removed A/C compressor where it will not be a hindrance when removing and installing the engine assembly, and tie it with a cord.

◀C▶ ENGINE MOUNT BRACKET REMOVAL

1. Support the engine with a garage jack.
2. Remove the mechanical hanger (recommended tool) which was attached when the transmission assembly was removed.
3. Hold the engine assembly with a chain block or similar tool.
4. Place a garage jack against the engine oil pan with a piece of wood in between, jack up the engine so that the weight of the engine is no longer being applied to the engine mount bracket, and then remove the engine mount bracket.

◀D▶ ENGINE ASSEMBLY REMOVAL

After checking that all cables, hoses and harness connectors, etc., are disconnected from the engine, lift the chain block slowly to remove the engine assembly upward from the engine compartment.

INSTALLATION SERVICE POINTS**▶A◀ENGINE ASSEMBLY INSTALLATION**

Install the engine assembly, checking that the cables, hoses, and harness connectors are not clamped.

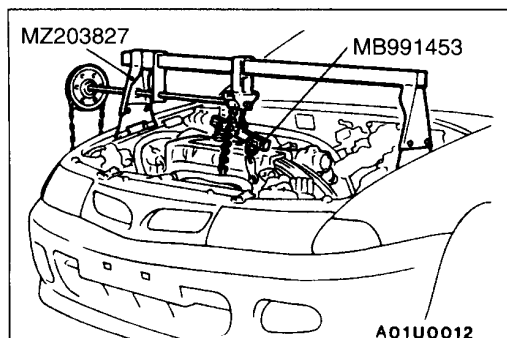
**▶B◀ENGINE MOUNT BRACKET INSTALLATION**

1. Place a garage jack against the engine oil pan with a piece of wood in between, and install the engine mount bracket while adjusting the position of the engine.
2. Support the engine with the garage jack.
3. Remove the chain block and support the engine assembly with the mechanical hanger (recommended tool).

▶C◀FUEL HIGH PRESSURE HOSE INSTALLATION

1. Apply a small amount of new engine oil to the O-ring.

Caution

- Do not let any engine oil get into the delivery pipe.

2. While turning the fuel high-pressure hose to the right and left, install the delivery pipe, while being careful not to damage the O-ring. After installing, check that the hose turns smoothly.
3. If the hose does not turn smoothly, the O-ring is probably being clamped. Disconnect the fuel high-pressure hose and check the O-ring for damage. After this, re-insert the delivery pipe and check that the hose turns smoothly.
4. Tighten to the specified torque.