

REAR AXLE

CONTENTS

2710900031

GENERAL INFORMATION	2	ON-VEHICLE SERVICE	3
SERVICE SPECIFICATIONS	2	Wheel Bearing Axial Play Check	3
		Rear Hub Rotary-Sliding Resistance Check	3
		REAR AXLE HUB	4

GENERAL INFORMATION

27100010040

The wheel bearing adopted is a unit ball bearing (double-row angular contact ball bearing), which uses the inside surface of the rear hub as the bearing outer race to reduce weight and size. This bearing has excellent service efficiency since

it is so constructed that appropriate bearing preload is available just by tightening the lock nut to the specified torque.

On vehicles with ABS, the rotor for detecting the wheel speed is installed on the rear hub.

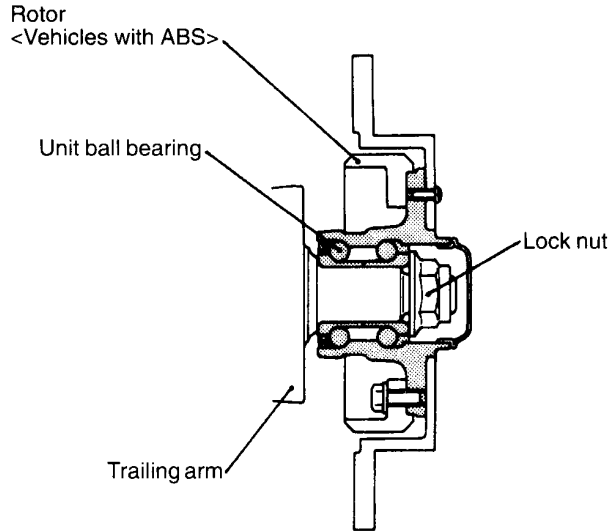

A11S0058

SERVICE SPECIFICATIONS

27100030046

Items	Standard value	Limit
Clearance of the rear speed sensor's pole piece and rotor <Vehicles with ABS> mm	0.3–0.9	–
Wheel bearing axial play mm	–	0.05
Wheel bearing rotary-sliding resistance N	–	19 or less

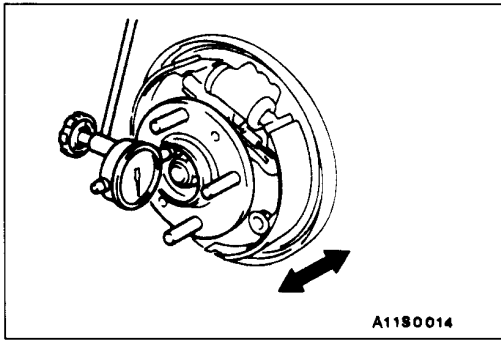

ON-VEHICLE SERVICE

27100090020

WHEEL BEARING AXIAL PLAY CHECK

1. Remove the hub cap and then release the parking brake.
2. Remove the brake drum.
3. For vehicles with rear disc brake, remove the caliper assembly and the brake disc.
4. Check the bearing's axial play.
Place a dial gauge against the hub surface; then move the hub in the axial direction and check whether or not there is axial play.

Limit: 0.05 mm

5. If the axial play exceeds the limit, the flange nut should be tightened to the specified torque (180 Nm) and check the axial play again.
6. Replace the rear hub assembly if an adjustment cannot be made to within the limit.

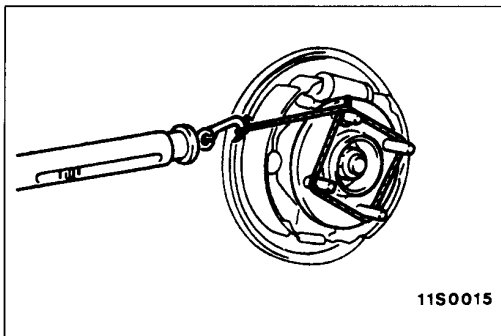

REAR HUB ROTARY-SLIDING RESISTANCE CHECK

27100110030

1. Release the parking brake.
2. Remove the brake drum.
3. For vehicles with rear disc brake, remove the caliper assembly and the brake disc.
4. After turning the hub a few times to seat the bearing, wind a rope around the hub bolt and turn the hub by pulling at a 90° angle with a spring balance. Measure to determine whether or not the rotary-sliding resistance of the rear hub is at the limit value.

Limit: 19 N or less

5. If the limit value is exceeded, loosen the flange nut and then tighten it to the specified torque (180 Nm) and check the rear hub rotary sliding resistance again.
6. Replace the rear hub assembly if an adjustment cannot be made to within the limit.

REAR AXLE HUB

REMOVAL AND INSTALLATION

Post-installation Operation

- Adjustment of Parking Brake
 <Vehicles with rear disc brake>
 (Refer to GROUP 36 – On-vehicle Service.)

<Vehicles with rear disc brake>

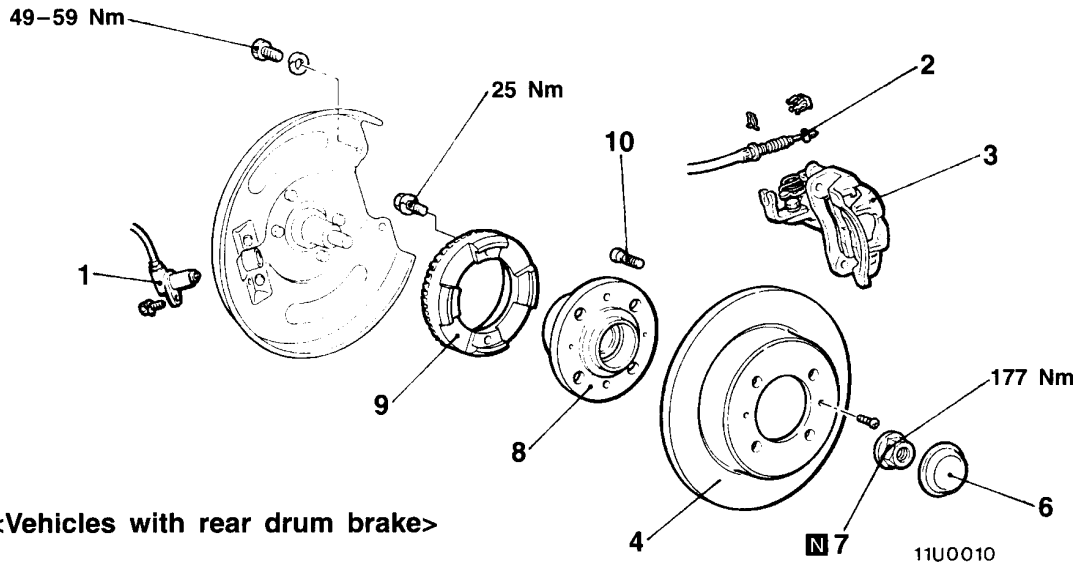

<Vehicles with rear drum brake>

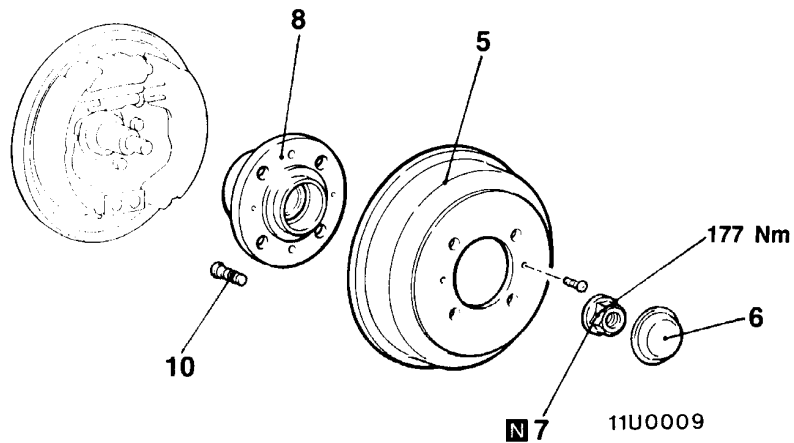

00003288

Removal steps

- ▶◀ 1. Rear speed sensor
 <Vehicles with ABS>
- ◀▶ 2. Parking brake cable connection
- 3. Caliper assembly
- 4. Brake disc
- 5. Brake drum
- 6. Hub cap
- 7. Flange nut
- 8. Rear hub assembly
- 9. Rotor <Vehicles with ABS>
- 10. Hub bolt

Caution

The rear hub unit bearing should not be dismantled. Care must be taken not to scratch or otherwise damage the teeth of the rotor. The rotor must never be dropped. If the teeth of the rotor are chipped, resulting in a deformation of the rotor, it will not be able to accurately detect the wheel rotation speed, and the system will not function normally. Replace rear hub assembly with new one, if bearing inner-ring comes out.

REMOVAL SERVICE POINT**◀A▶ CALIPER ASSEMBLY REMOVAL**

Remove the caliper assembly and suspend it.

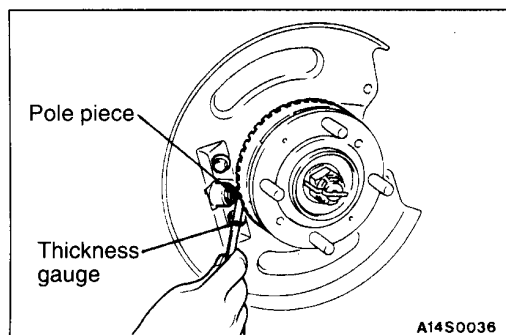
**INSTALLATION SERVICE POINT****▶A◀ REAR SPEED SENSOR INSTALLATION
<VEHICLES WITH ABS>**

- (1) Provisionally install the speed sensor to the sensor bracket.
- (2) With the caliper assembly and brake disc removed, insert a thickness gauge into the space between the speed sensor's pole piece and the rotor's toothed surface, and then tighten the speed sensor bracket at the position where the clearance at all places is within the standard value.

Standard value: 0.3–0.9 mm

INSPECTION

27100210075

- Check the oil seal for crack or damage.
- Check the rear hub unit bearing for wear or damage.
- Check the rear rotor for chipped teeth.