BODY

CONTENTS

4210900041

HOOD	3	TROUBLESHOOTING	14
FENDER	4	ON-VEHICLE SERVICE	26
SEALANT	4	Door Fit Adjustment	26
FENDER	4	Adjustment and Replacement When There is a Malfunction of the Power Window	26
FUEL FILLER DOOR	5	Power Window Safety Mechanism Check	27
WINDOW GLASS	6	Door Outside Handle Play Check	27
ADHESIVES	6	Door Inside Handle Play Check	27
SPECIAL TOOL	6	Power Window Initial Setting	27
WINDOW REPAIR	6	DOOR ASSEMBLY	28
WINDSHIELD	8	DOOR TRIM AND WATERPROOF FILM	30
TAILGATE WINDOW GLASS	11	DOOR GLASS AND REGULATOR	32
DOOR	13	DOOR HANDLE AND LATCH	35
SERVICE SPECIFICATIONS	13	WINDOW GLASS RUNCHANNEL AND DOOR OPENING WEATHERSTRIP	38
SEALANT	13		
SPECIAL TOOLS	13		

CONTINUED ON NEXT PAGE

TAILGATE	39	How to Register a Secret Code	52
SPECIAL TOOL	39	KEYLESS ENTRY RECEIVER ECU	53
TROUBLESHOOTING	39	THEFT ALARM HORN	53
TAILGATE ASSEMBLY	40	SUNROOF	54
TAILGATE TRIM	42	SPECIAL TOOLS	54
TAILGATE LATCH	42	TROUBLESHOOTING	54
KEYLESS ENTRY SYSTEM	44	ON-VEHICLE SERVICE	57
SPECIAL TOOLS	44	Water Test	57
TROUBLESHOOTING	44	Sunroof Fit Adjustment	57
ON-VEHICLE SERVICE	51	SUNROOF	58
Battery Replacement	51		

HOOD

42100160045

REMOVAL AND INSTALLATION

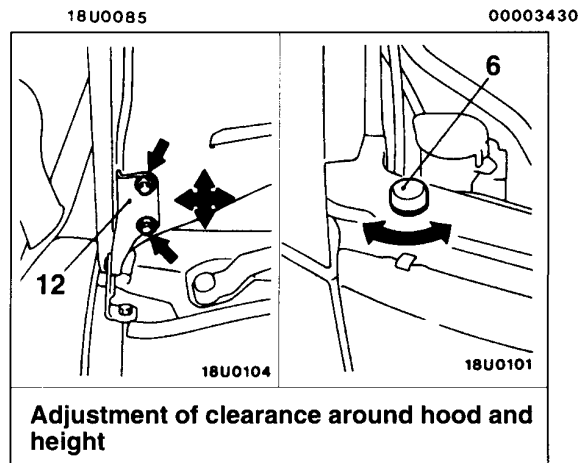
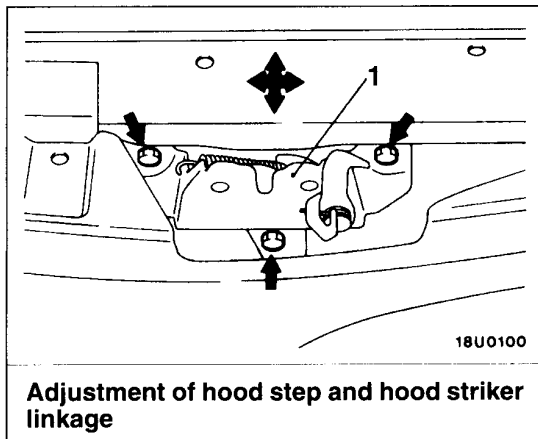
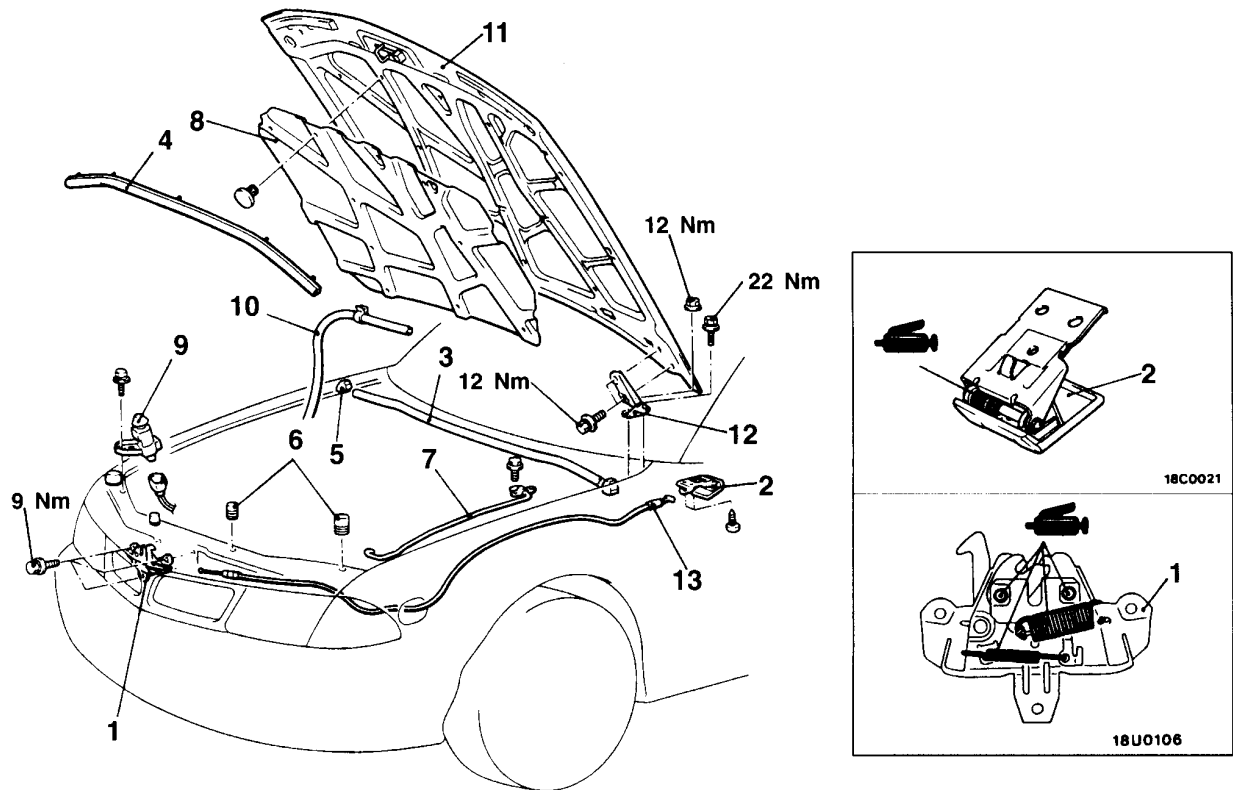

1. Hood latch
2. Hood lock release handle
3. Hood weatherstrip
4. Hood weatherstrip
<Vehicles with air conditioner>
5. Hood side weatherstrip
6. Bumper
7. Hood support rod
8. Hood insulator
9. Hood switch
<Vehicles with shaftalarm system>

Hood and hood hinge removal steps

10. Washer hose connection
11. Hood
 - Front deck garnish
12. Hood hinge

Hood lock release cable removal steps

- Splash shield <Driver's side>
(Refer to P.42-4.)
13. Hood lock release cable

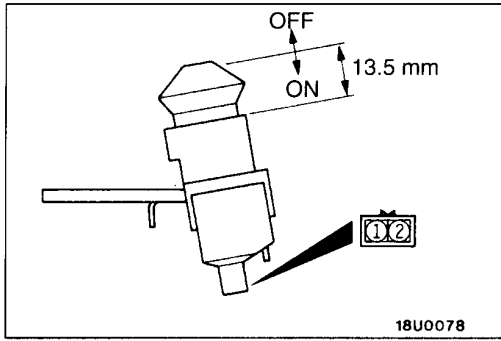

INSPECTION
HOOD SWITCH CONTINUITY CHECK

42100390024

Switch position	Terminal No.	
	1	2
Hood switch unpressed (OFF)	○	○
Hood switch depressed (ON)		

FENDER

42100050045

SEALANT

Item	Specified sealant	Remark
Splash shield	3M ATD Part No. 8625 or equivalent	Ribbon sealer

FENDER

42100190044

REMOVAL AND INSTALLATION

Pre-removal and Post-installation Operation

(1) Front Bumper Removal and Installation (Refer to GROUP 51.)

(2) Headlamp Removal and Installation (Refer to GROUP 54.)

(3) Side Airdam Removal and Installation (Refer to GROUP 51 – Aero Parts.)

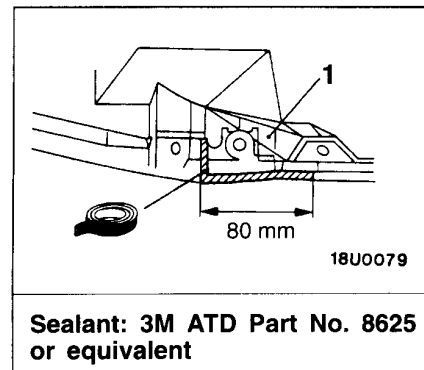
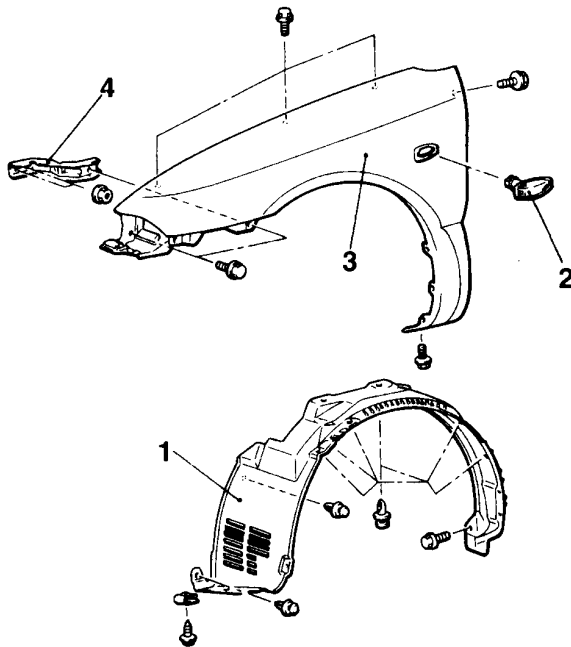

00003431

Removal steps

1. Splash shield
2. Side turn signal lamp (Refer to GROUP 54.)
3. Fender
4. Fender support bracket

FUEL FILLER DOOR

42100250056

REMOVAL AND INSTALLATION

Pre-removal and Post-installation Operation

- (1) Front Seat (driver's side), Rear Seat Removal and Installation (Refer to GROUP 52A.)
- (2) Centre Pillar Lower Trim (driver's side), Front Scuff Plate (driver's side), Rear Scuff Plate (driver's side),

Rear End Trim, Rear Side Trim (L.H.) Removal and Installation (Refer to GROUP 52A.)

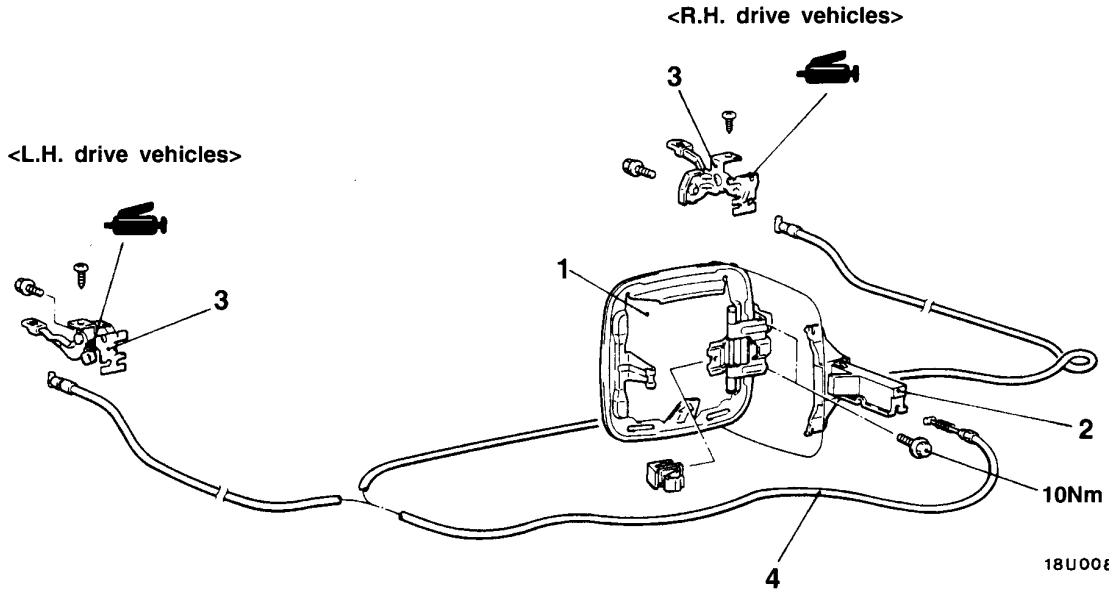

18U0084

00003432

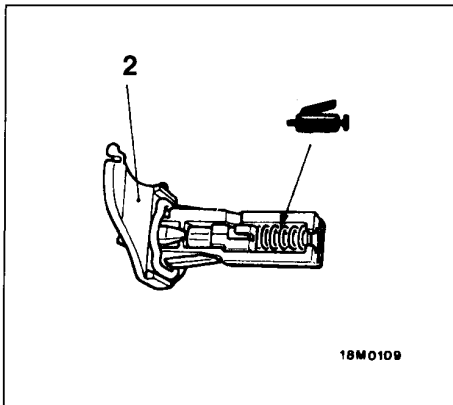

18M0109

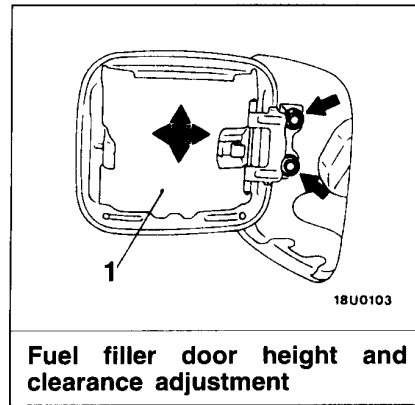

18U0103

Fuel filler door height and clearance adjustment

Removal steps

- 1. Fuel filler door assembly
- 2. Fuel filler lock hook assembly
- 3. Lid lock release handle
- 4. Fuel filler door lock release cable

WINDOW GLASS

42200050031

ADHESIVES

Items	Specified adhesives
Windshield	3M ATD Part No. 8609 Super Fast Urethane Auto Glass Sealants or equivalent
Tailgate window glass	

SPECIAL TOOL

42200060034

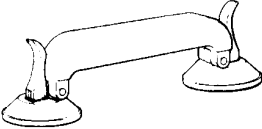
Tool	Number	Name	Use
	MB990480	Glass holder	<ul style="list-style-type: none"> • Removal and installation of windshield • Removal and installation of tailgate window glass

WINDOW REPAIR

42200560015

The following glass sections are installed by means of a liquid urethane adhesive method.

- Windshield
- Tailgate window glass

ITEMS NEEDED

Name	Remarks
Adhesive	3M ATD Part No. 8609 Super Fast Urethane Auto Glass Sealant or equivalent
Primer	3M ATD Part No. 8608 Super Fast Urethane Primer or equivalent
Spacers	Available as service part
Anti-rust solvent (or Tectyl 506T...Valvoline Oil Company)	For rust prevention
Isopropyl alcohol	For grease removal from bonded surface
Steel piano wire	Dia. × length...0.6mm × 1m For cutting adhesive
Adhesive gun	For pressing-out adhesive

NOTE

The TEROSON 127.37V auto window sealer kit can also be used. If using the TEROSON 127.37V auto window sealer kit, follow the instructions in the manual included with the kit.

HANDLING OF AUTO WINDOW SEALER

Keep the sealant in a cool place, not exposed to the direct rays of the sun. Do not place any heavy article on the sealant nor press it, otherwise it will become deformed. Avoid storing the sealant for more than 6 months, because it will lose its sealing effect.

BODY PINCH-WELD FLANGE SERVICING.

Before servicing the body pinch-weld flange, remove old adhesive completely. If the flange requires painting, bake it after painting is completed.

WORKING PROCESS

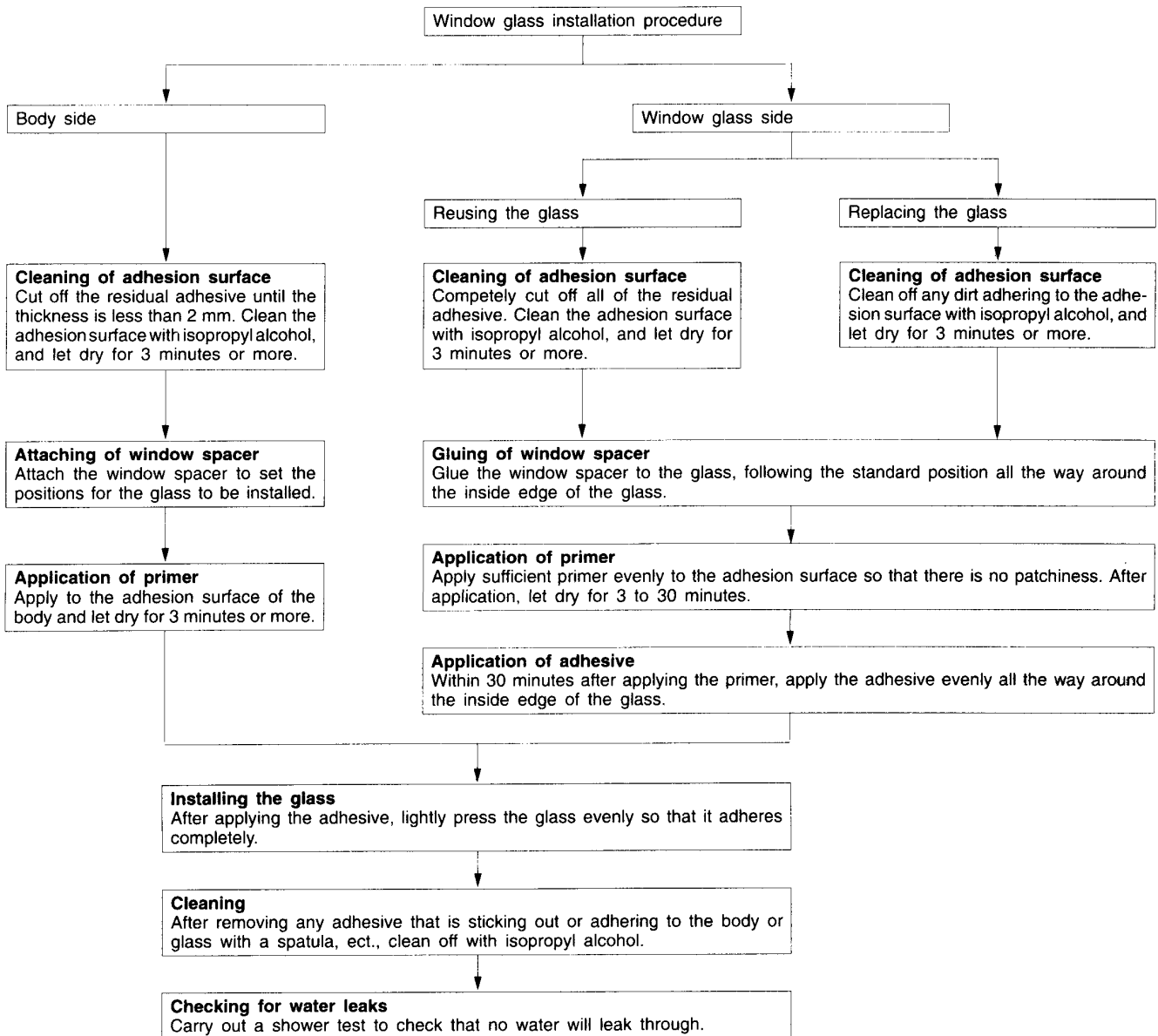

WINDSHIELD

42200100040

REMOVAL AND INSTALLATION

Pre-removal and Post-installation Operation
Removal and Installation

(1) Front Deck Garnish	(3) Headlining
(2) Front Pillar Trim (Refer to GROUP 52A.)	(4) Front Pillar Drip Moulding (Refer to GROUP51.)

Adhesive application dimension of D point

D mm	0	100	200	300	400	500	600
E mm	6	7.5	12	16	13.5	17.5	25.5

Section A-A **Section C-C** mm

Section B-B

Adhesive: 3M ATD Part No. 8609 Super Fast Urethane Auto Glass Sealant or equivalent

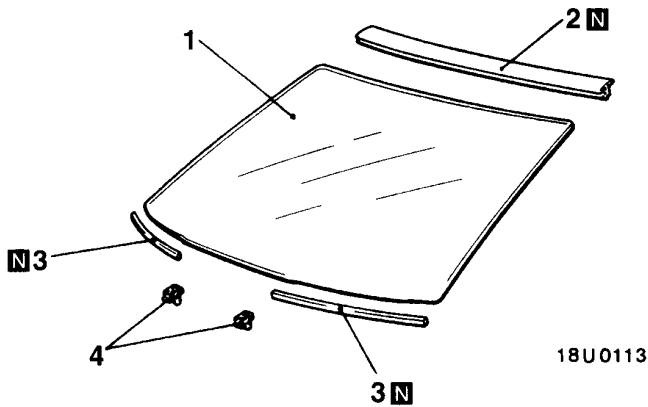

00003433

- Removal steps**
- ◀A▶ ▶B◀ 1. Windshield
 - ▶A◀ 2. Windshield moulding
 - ▶A◀ 3. Window spacer
 - ▶A◀ 4. Window spacer

REMOVAL SERVICE POINT

◀A▶ WINDSHIELD REMOVAL

1. In order to protect the body (paint surface), apply cloth tape to all body areas around the installed windshield glass.
2. Cut the moulding with a cutter knife.

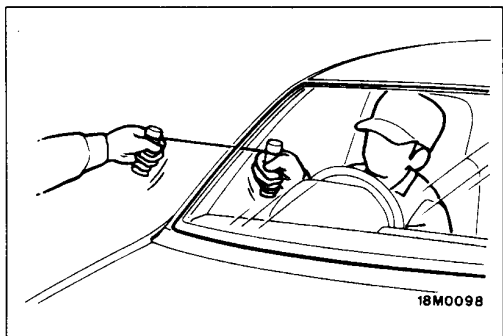

3. Using a sharp-point drill, make hole in the windshield glass adhesive.
4. Pass the piano wire from the inside of the vehicle through the hole.
5. Pull the piano wire alternately from the inside and outside along the windshield glass to cut the adhesive.

Caution

Do not let the piano wire touch the edge of the windshield glass.

6. Make mating marks on the windshield glass and body.
7. Use the special tool to remove the windshield glass.

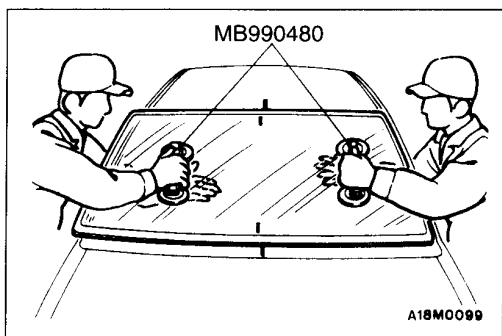

8. Use a knife to cut away the remaining adhesive so that the thickness is within 2 mm around the entire circumference of the body flange.
9. Finish the flange surfaces so that they are smooth

Caution

(1) Be careful not to remove more adhesive than is necessary.

(2) Be careful also not to damage the paintwork on the body surface with the knife. If the paintwork is damaged, repair the damaged area with repair paint or anti-rust agent.

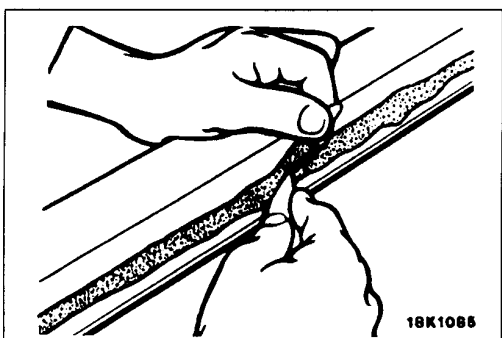

10. When reusing the glass, remove the adhesive still adhering to the glass, and clean with isopropyl alcohol.
11. Clean the body side in the same way.

Caution

Let the cleaned places stand for 3 minutes or more, and carry out the next procedures after they have dried. Also, do not touch any surface that has been cleaned.

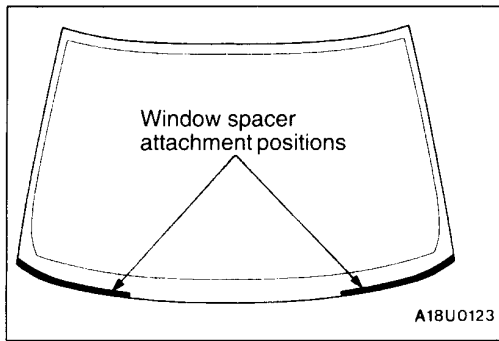

INSTALLATION SERVICE POINTS

▶A◀ WINDOW SPACER INSTALLATION

After wiping the window spacer adhesion surfaces of the windshield with isopropyl alcohol to remove any grease, attach the window spacers in the positions shown in the illustration.

▶B◀ WINDSHIELD INSTALLATION

1. When replacing the glass, temporarily set the glass against the body, and place a mating mark on the glass and body.
2. Use isopropyl alcohol to degrease the inside and outside of the windshield glass and the body flanges.
3. Soak a sponge in the primer, and apply evenly to the glass and the body in the specified places.
4. Apply the primer, and then let it dry for 3 to 30 minutes.

Caution

- (1) **The primer strengthens the adhesive, so be sure to apply it evenly around the entire circumference. However, a too thick application will weaken the adhesive.**
- (2) **Do not touch the coated surface.**

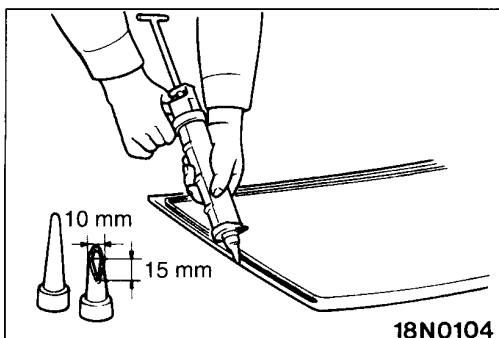

5. Fill a sealant gun with adhesive. Then apply the adhesive evenly around the windshield within 30 minutes after applying the primer.

NOTE

Cut the tip of the sealant gun nozzle into a V shape to simplify adhesive application.

6. Align the mating marks on the glass and the body, and lightly press the windshield glass evenly so that it adheres completely.
7. Use a spatula or the like to remove any excessive adhesive. Then clean the surface with isopropyl alcohol. Try not to move the vehicle until the adhesive sets.
8. Wait 30 minutes or more, and then test for water leakage.

Caution

- (1) **Do not move the vehicle unless absolutely necessary.**
- (2) **When testing for water leakage, do not pinch the end of the hose to spray the water.**

TAILGATE WINDOW GLASS

42200370021

REMOVAL AND INSTALLATION

**Pre-removal and Post-installation Operation
Removal and Installation**

- (1) Rear Wiper Blade and Arm Assembly (Refer to GROUP 51.)
- (2) High Mounted Stop Lamp (Refer to GROUP 54.)
- (2) Tailgate Upper Trim, Tailgate Side Trim and Tailgate Lower Trim (Refer to P.42-42.)

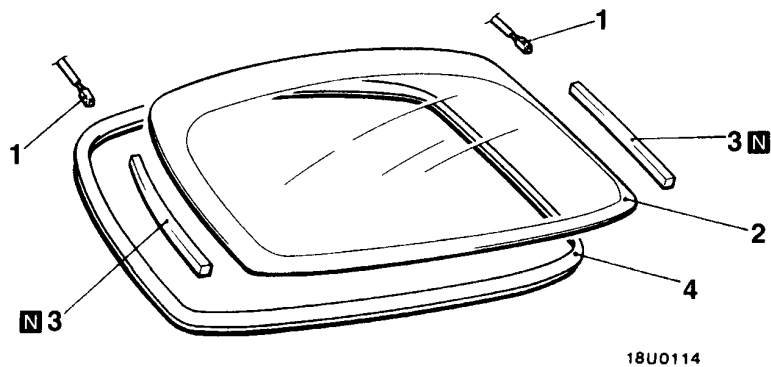
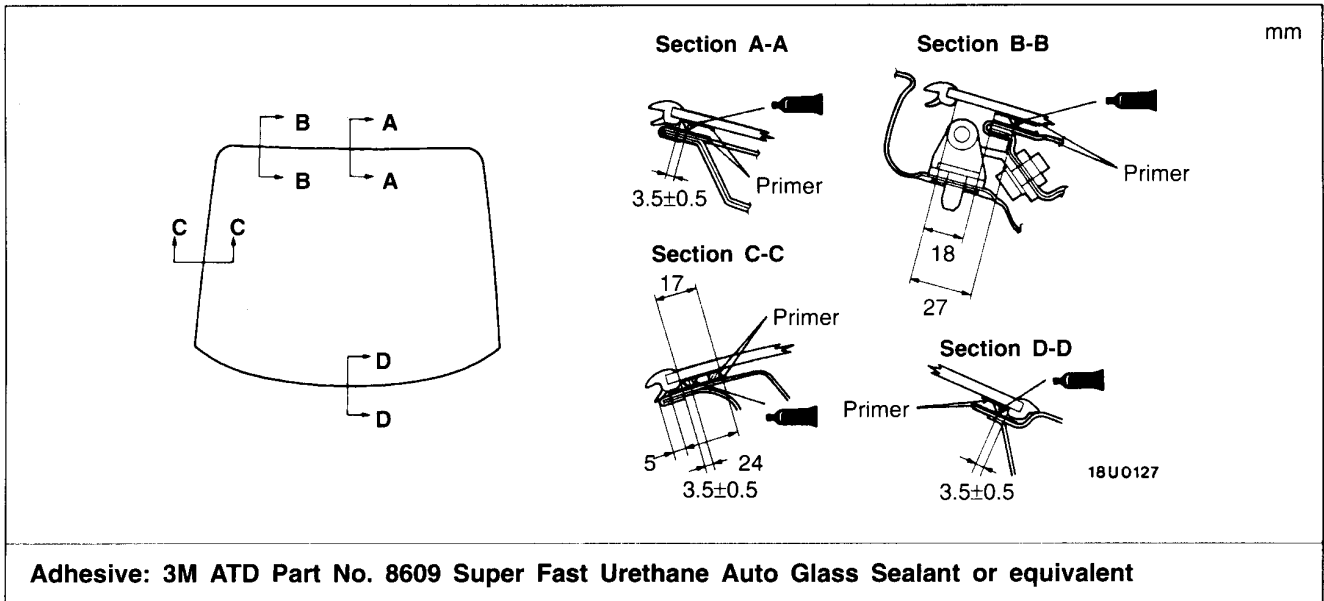

00003434

Removal steps



1. Harness connector
2. Tailgate window glass
3. Window spacer
4. Tailgate moulding

REMOVAL SERVICE POINT**◀A▶ TAILGATE WINDOW GLASS REMOVAL**

Remove the tailgate window glass by the same procedure as for the windshield. (Refer to P.42-9.)

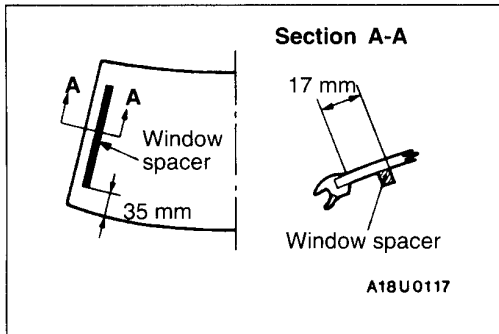
**INSTALLATION SERVICE POINTS****▶A◀ WINDOW SPACER INSTALLATION**

After wiping the window spacer adhesion surfaces of the tailgate window glass with isopropyl alcohol to remove any grease, attach the window spacers in the positions shown in the illustration.

▶B◀ TAILGATE WINDOW GLASS INSTALLATION

Apply primer and adhesive in the specified position, and then install the tailgate window glass by the same procedure as for the windshield. (Refer to P.42-10.)

DOOR

42300030038

SERVICE SPECIFICATIONS

Items		Standard value
Door outside handle play mm	FRONT DOOR	3.7–4.7
	REAR DOOR	2.9–4.9
Door inside handle play mm	FRONT DOOR	20.5–22.5
	REAR DOOR	14.2–15.2

SEALANT

42300050034

Items	Specified sealant	Remark
Waterproof film	3M ATD Part No. 8625 or equivalent	Ribbon sealer

SPECIAL TOOLS

42300060037

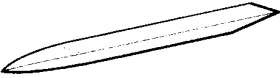
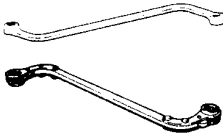
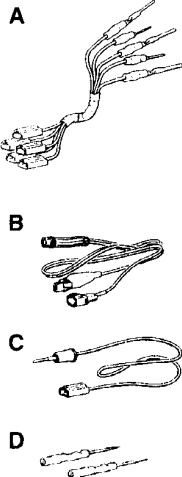
Tool	Number	Name	Use
	MB990784	Ornament remover	Removal of front door trim
 00003936	MB990900 or MB991164	Door adjusting wrench	Adjustment of door fit
	MB991223 A: MB991219 B: MB991220 C: MB991221 D: MB991222	Harness set A: Test harness B: LET harness C: LED harness adapter D: probe	Measurement of terminal voltage A: Connector pin contact pressure inspection B, C: Power circuit inspection D: Commercial tester connection

TROUBLESHOOTING

42300070030

INSPECTION CHART FOR TROUBLE SYMPTOMS

Trouble symptom		Inspection procedure	Reference page	
Power windows	Driver's power window cannot be operated by the power window main switch.	1	42-15	
	No power window can be operated by the power window main switch (but they can be operated by the sub-switches).	2	42-16	
	No power window can be operated by the power window sub-switches (but they can be operated by the main switch).	3	42-16	
	No power window can be operated by the power window sub-switches (nor can they be operated by the main switch).	4	42-17	
	Automatic operation is not possible.	5	42-19	
	When the glass is raised, it then lowers automatically.	6	42-20	
	The window does not lower if it clamps something, or it lowers automatically after closing fully.	7	42-21	
	The key off timer does not operate.	8	42-21	
	If the driver's side door is opened while the key off timer is operating, the power windows do not operate for a further 30 seconds after the door is opened.	9	42-21	
Door locking mechanism	Vehicles without keyless entry system	None of the door lock functions operate.	10	42-21
		Doors do not lock or unlock when the key cylinders (except the one at the driver's side door) are operated.	11	42-22
		When the key cylinders (except the one at the driver's side door) are operated and the doors are unlocked, they lock again when the key is turned to the neutral position; or the doors do not lock or unlock when the driver's door inside lock knob or the driver's door key cylinder is operated.	12	42-23
		Some doors do not lock or unlock.	13	42-23

Trouble symptom		Inspection procedure	Reference page
Door locking mechanism	Vehicles with keyless entry system	None of the door lock functions operate. (The keyless entry system also does not operate.)	14
		The doors do not lock or unlock when the driver's door inside lock knob is operated.	15
		The doors do not lock or unlock when the key cylinders are operated.	16
		Some doors do not lock or unlock.	17

INSPECTION PROCEDURE FOR TROUBLE SYMPTOMS

Inspection Procedure 1

Driver's power window cannot be operated by the power window main switch.	Probable cause
The power window main switch or power window regulator assembly may be defective.	<ul style="list-style-type: none"> ● Malfunction of power window regulator assembly ● Malfunction of power window main switch ● Malfunction of wiring harness or connector

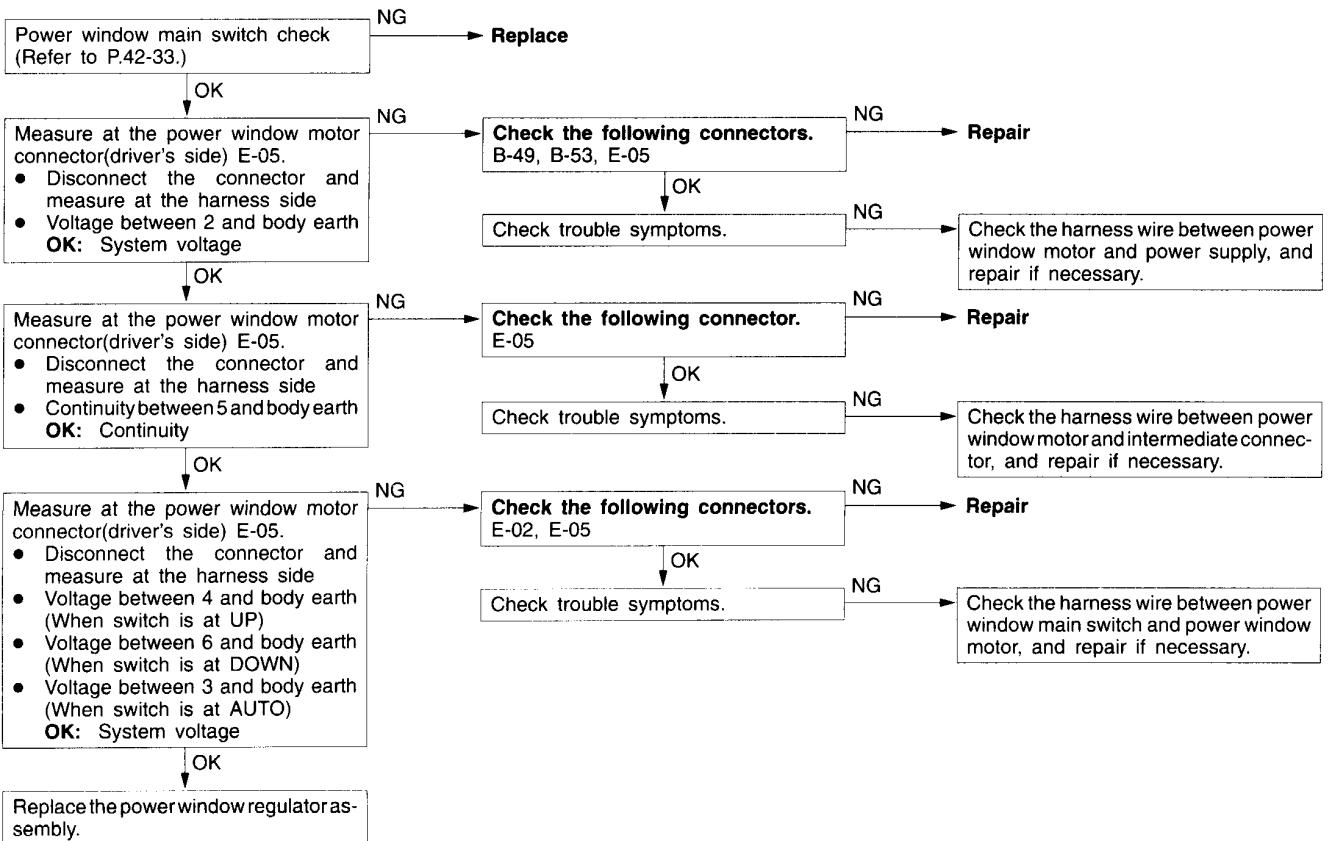

Inspection Procedure 2

<p>No power window can be operated by the power window main switch (but they can be operated by the sub-switches).</p>	<p>Probable cause</p> <ul style="list-style-type: none"> ● Malfunction of power window main switch ● Malfunction of wiring harness or connector
<p>The power window main switch or the harness between power window main switch and power window sub switch may be defective.</p>	

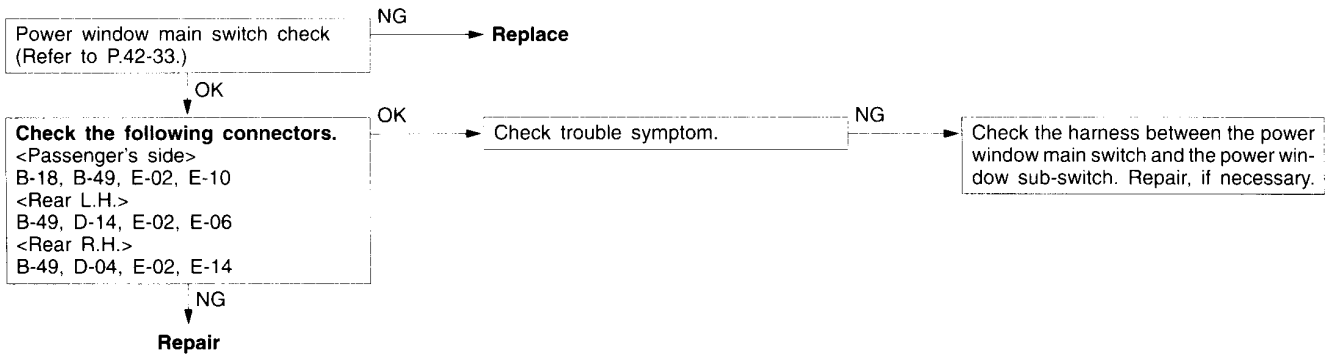

Inspection Procedure 3

<p>No power window can be operated by the power window sub-switches (but they can be operated by the main switch).</p>	<p>Probable cause</p> <ul style="list-style-type: none"> ● Malfunction of power window sub-switch ● Malfunction of wiring harness or connector
<p>The power window sub-switch or the power supply circuit of power window sub-switch may be defective.</p>	

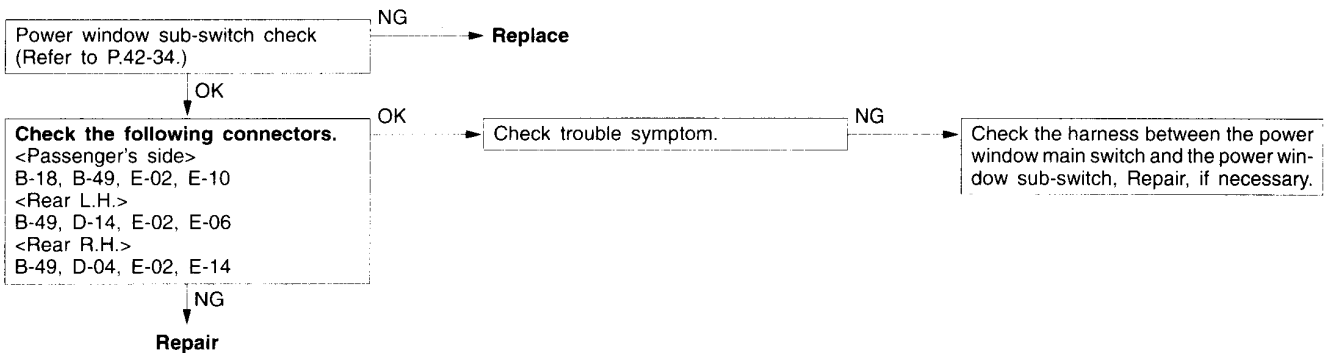

Inspection Procedure 4

<p>No power window can be operated by the power window sub-switches (nor can they be operated by the main switch).</p>	<p>Probable cause</p>
<p>The power window main switch, the power window sub-switch or power window regulator assembly may be defective.</p>	<ul style="list-style-type: none"> ● Malfunction of power window main switch ● Malfunction of power window sub-switch ● Malfunction of power window regulator assembly ● Malfunction of wiring harness or connector

<Passenger's side>

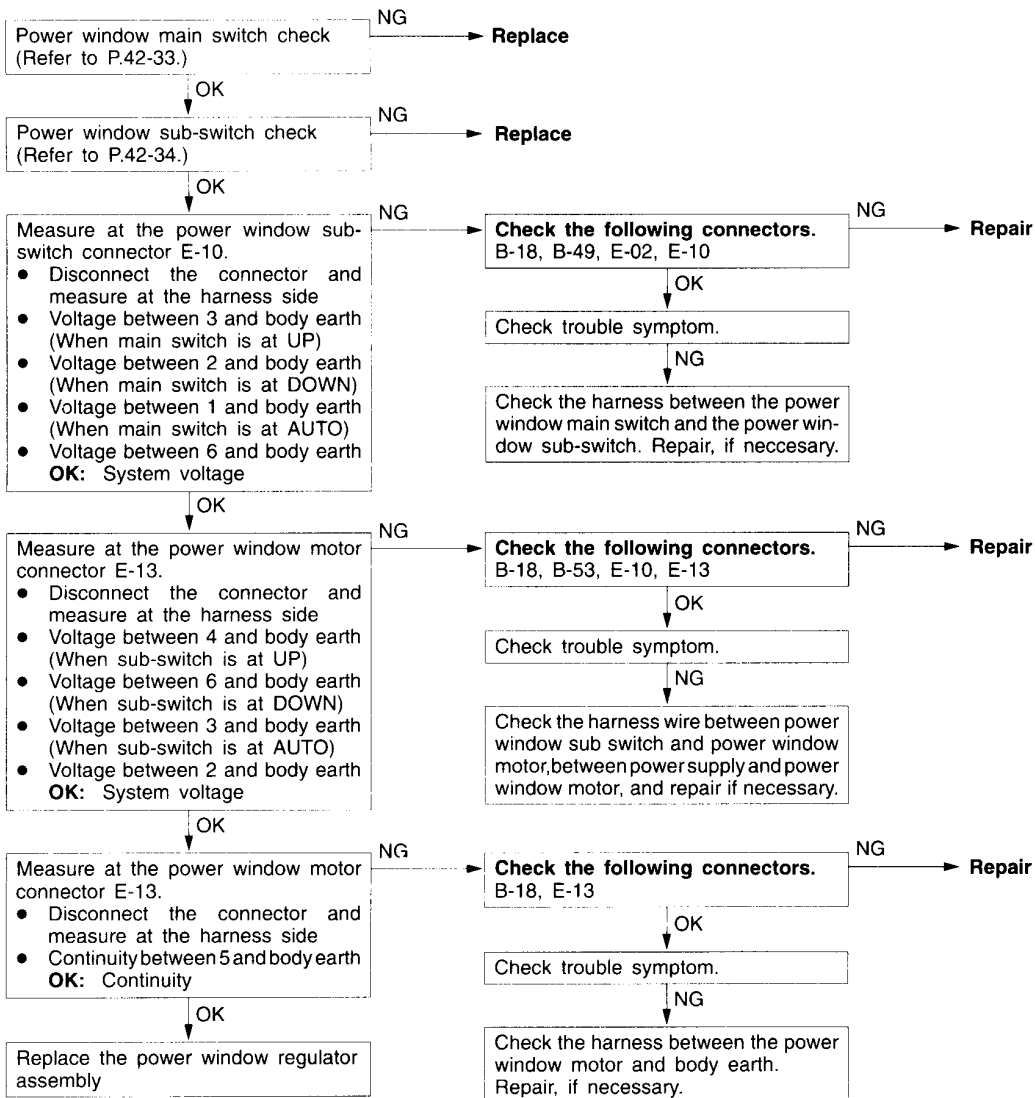

<Rear>

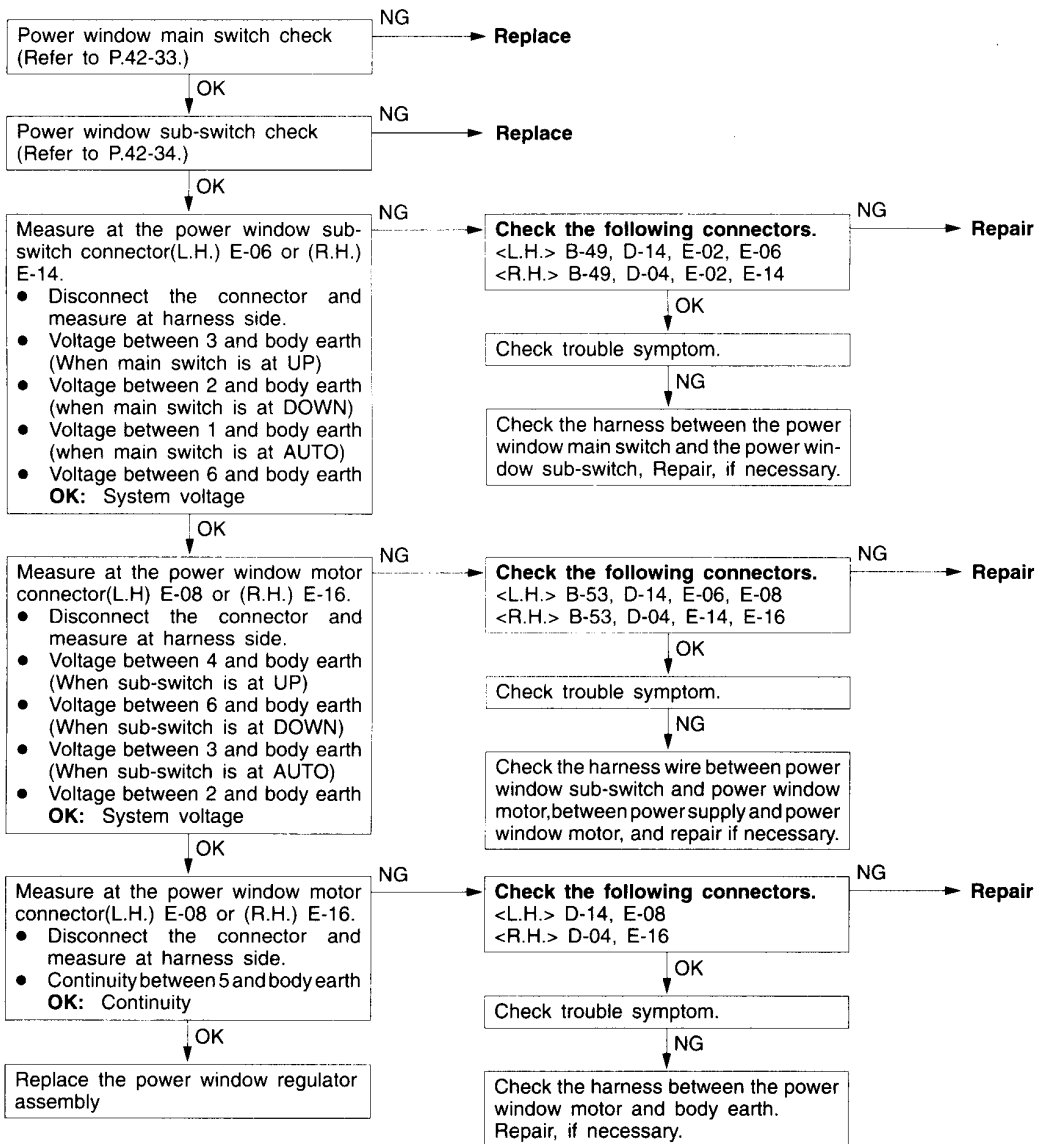

Inspection Procedure 5

Automatic operation is not possible.	Probable cause
Automatic operation is not possible before carrying out the initial setting operation when the battery terminals are disconnected or a fuse or power window regulator assembly is replaced. The cause may also be a malfunction of the power window switch or the power window regulator assembly.	<ul style="list-style-type: none"> ● Incorrect initial settings ● Malfunction of power window main switch ● Malfunction of power window sub-switch ● Malfunction of wiring harness or connector

<Driver's side>

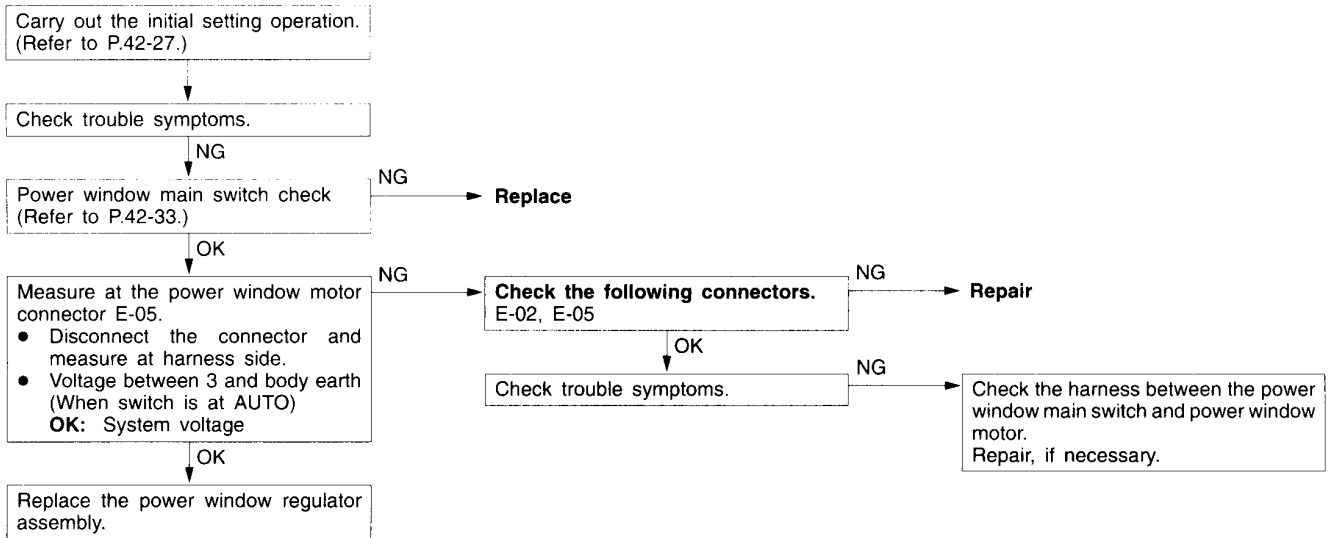

<Passenger's side>

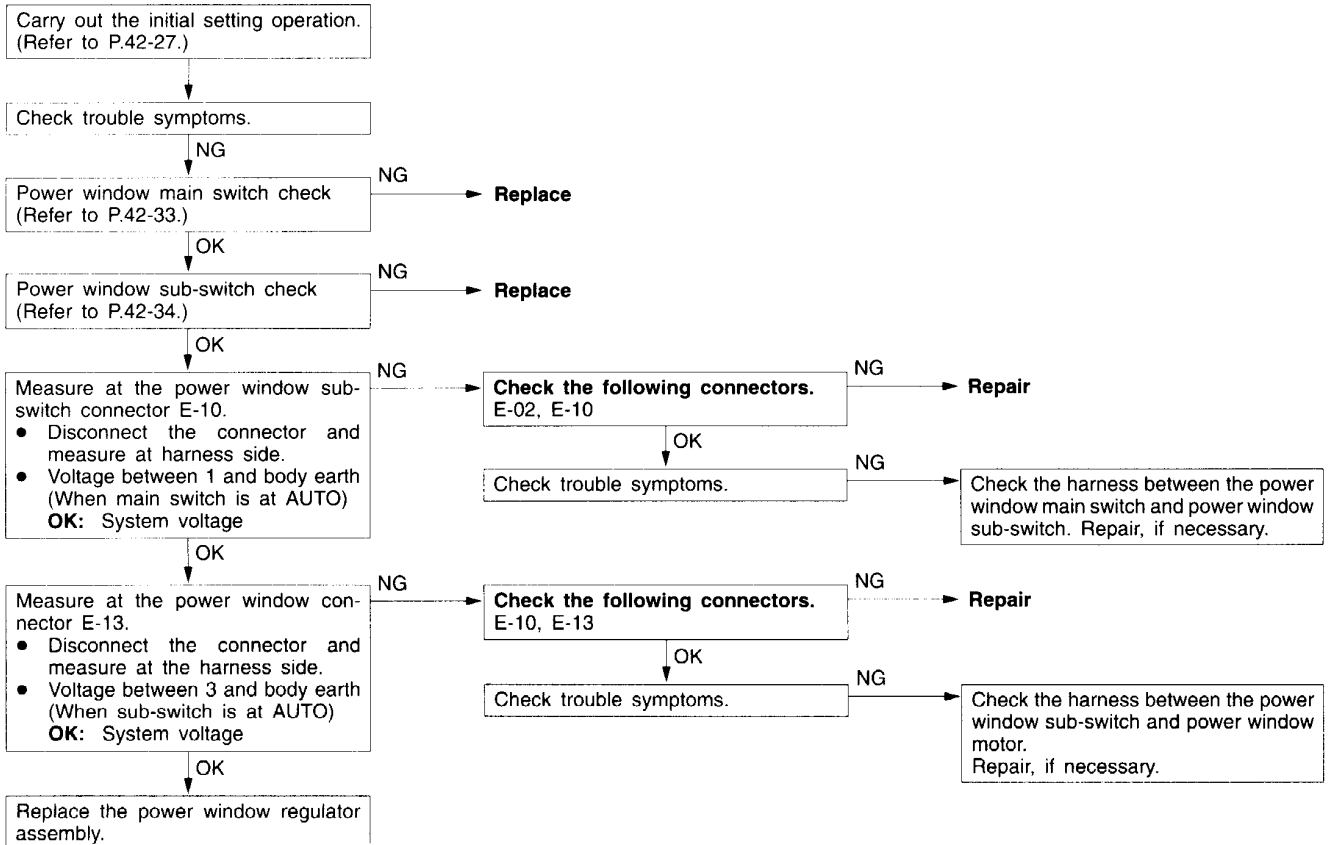

<Rear>

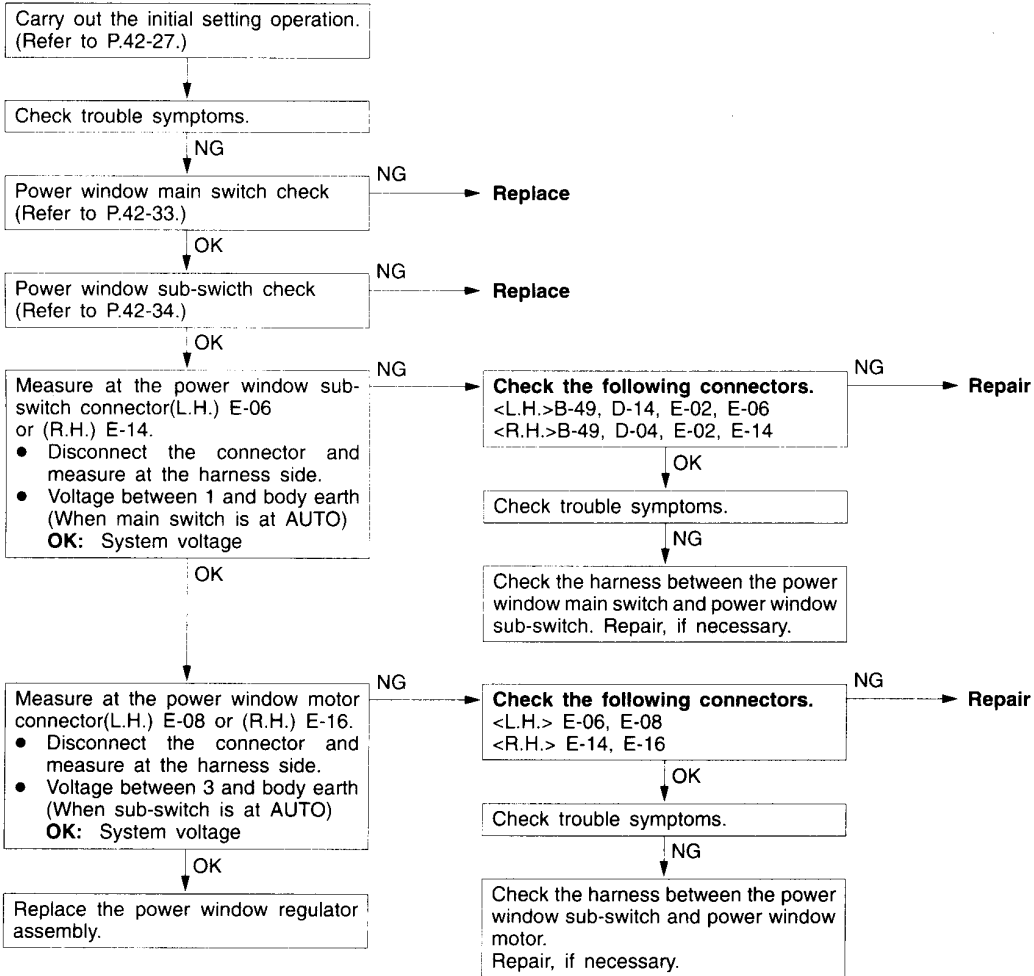

Inspection Procedure 6

When the glass is raised, it then lowers automatically.	Probable cause
The sliding resistance is too large when the glass rises. So it is misjudged that something is jammed in the window, and the window is lowered automatically.	<ul style="list-style-type: none"> • Incorrect installation or bending of the glass runners. • Malfunction of the power window regulator assembly

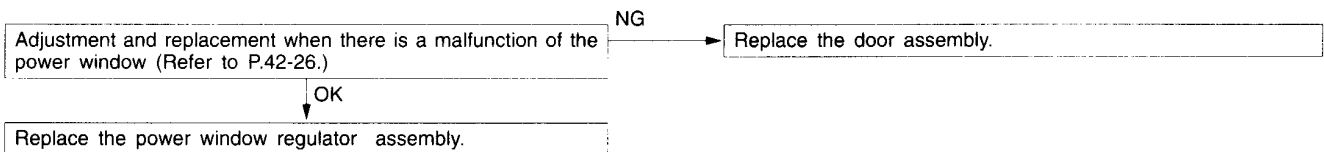

Inspection Procedure 7

The window does not lower if it clamps something, or it lowers automatically after closing fully.	Probable cause
If the window is not lowered when it is obstructed by something while it is more than 4 mm from the fully-closed position, or if it lowers automatically after it is fully closed, the cause is probably a malfunction of the power window regulator assembly.	<ul style="list-style-type: none"> Malfunction of the power window regulator

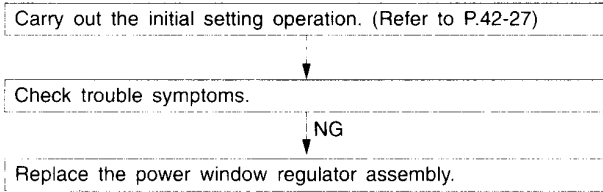

Inspection Procedure 8

The key off timer does not operate.	Probable cause
The power windows can be operated for a further 30 seconds after the ignition switch is turned to OFF, but if they cannot be operated during this time, there is probably a malfunction of the power window main switch.	<ul style="list-style-type: none"> Malfunction of the power window main switch.

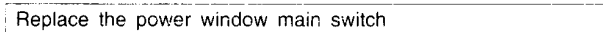

Inspection Procedure 9

If the driver's side door is opened while the key off timer is operating, the power windows do not operate for a further 30 seconds after the door is opened.	Probable cause
If the driver's door is opened within 30 seconds after the ignition switch is turned to OFF, the power windows can still be operated for 30 seconds after that point. If they cannot be operated during this time, there is probably a malfunction of the driver's side door switch or power window main switch.	<ul style="list-style-type: none"> Malfunction of the front door switch(driver's side) Malfunction of the power window main switch Malfunction of harness or connector

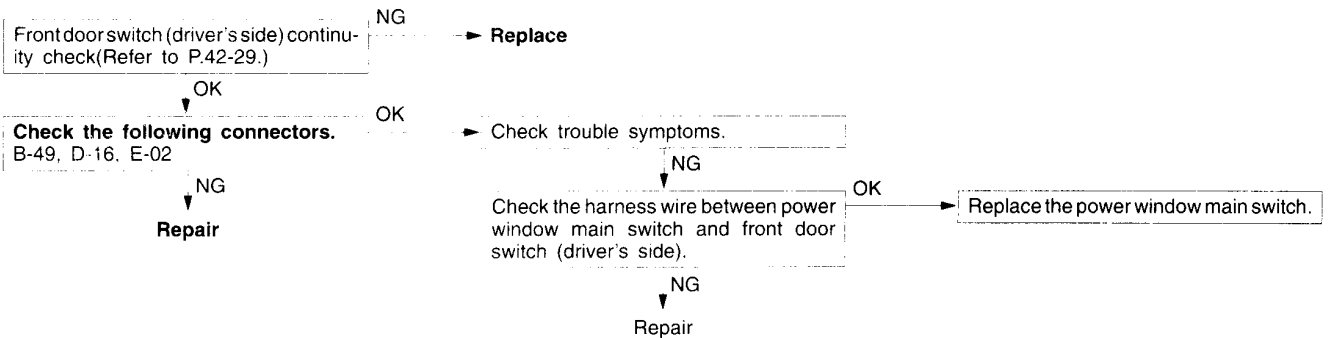

Inspection Procedure 10

None of the door lock functions operate.	Probable cause
Power circuit system or earth circuit system of the door lock control unit may be defective.	<ul style="list-style-type: none"> Malfunction of door lock ECU Malfunction of wiring harness or connector

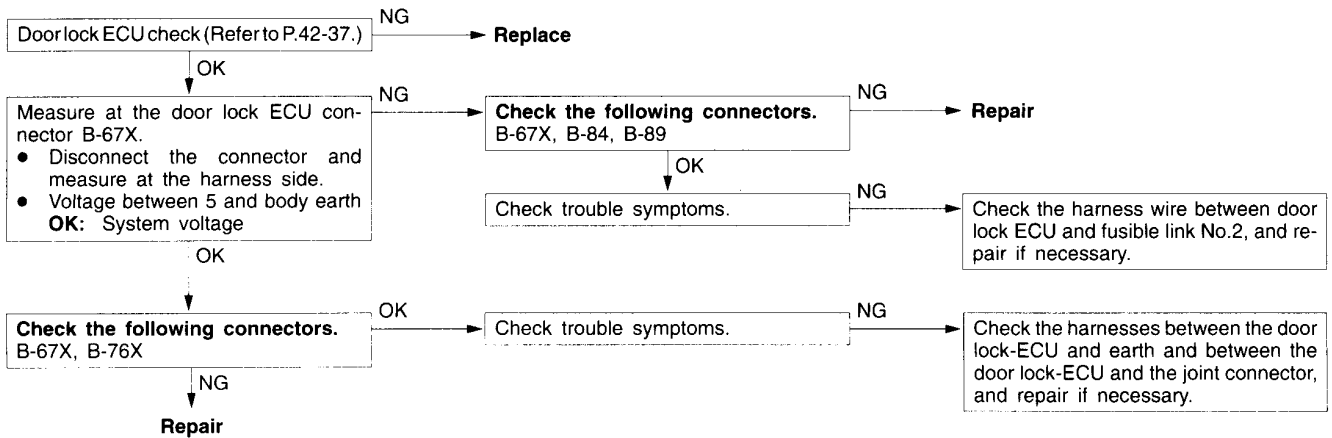

Inspection Procedure 11

Doors do not lock or unlock when the key cylinders (except the one at the driver's side door) are operated.	Probable cause
The key cylinder switch or the door lock ECU may be defective.	<ul style="list-style-type: none"> • Malfunction of the door lock key cylinder switch • Malfunction of the tailgate lock key cylinder switch • Malfunction of the door lock ECU • Malfunction of harness or connector

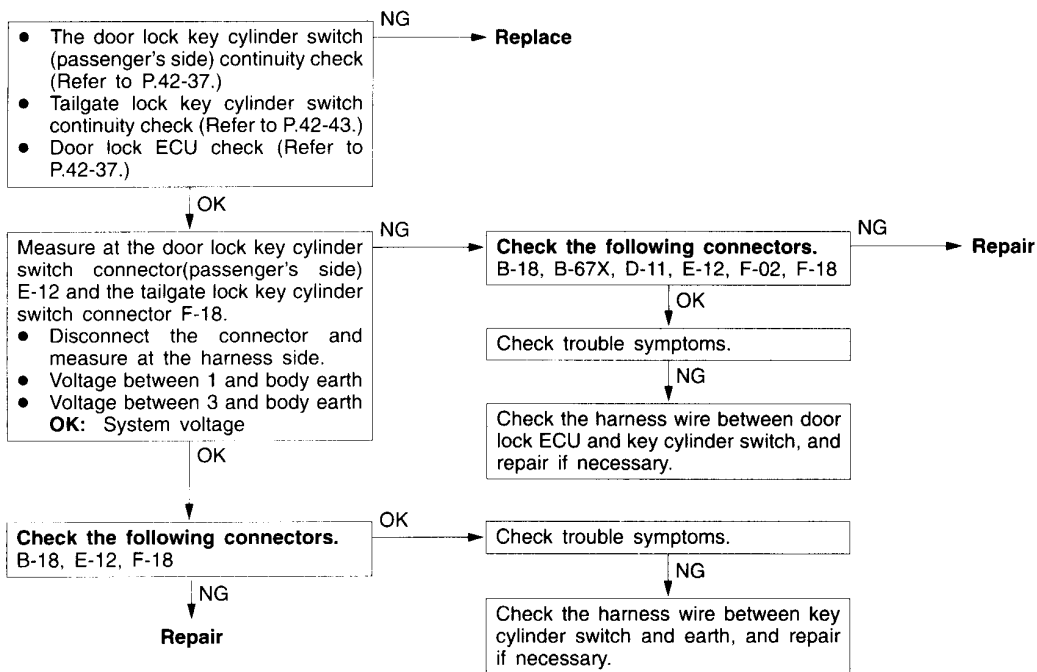

Inspection Procedure 12

<p>When the key cylinders (except the one at the driver's side door) are operated and the doors are unlocked, they lock again when the key is turned to the neutral position; or the doors do not lock or unlock when the driver's door inside lock knob or the driver's door key cylinder is operated.</p>	<p>Probable cause</p>
<p>The front door lock actuator(driver's side) may be defective or there may be open circuit in the input line of front door lock actuator(driver's side).</p>	<ul style="list-style-type: none"> ● Malfunction of the front door lock actuator(driver's side) ● Malfunction of the harness or connector

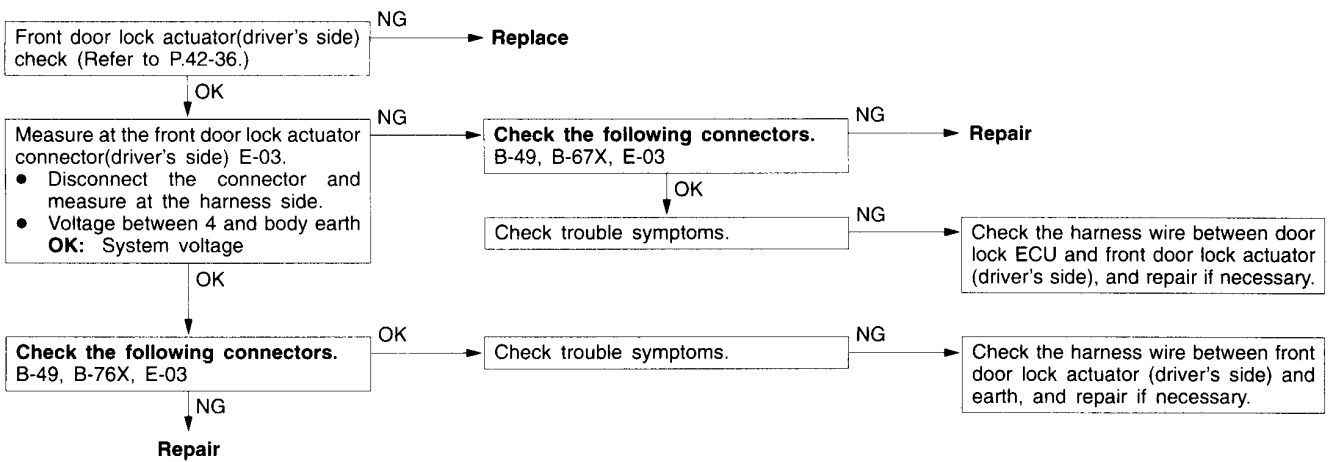

Inspection Procedure 13

<p>Some doors do not lock or unlock.</p>	<p>Probable cause</p>
<p>The door lock actuator, a harness or connector may be defective.</p>	<ul style="list-style-type: none"> ● Malfunction of door lock actuator ● Malfunction of wiring harness or connector

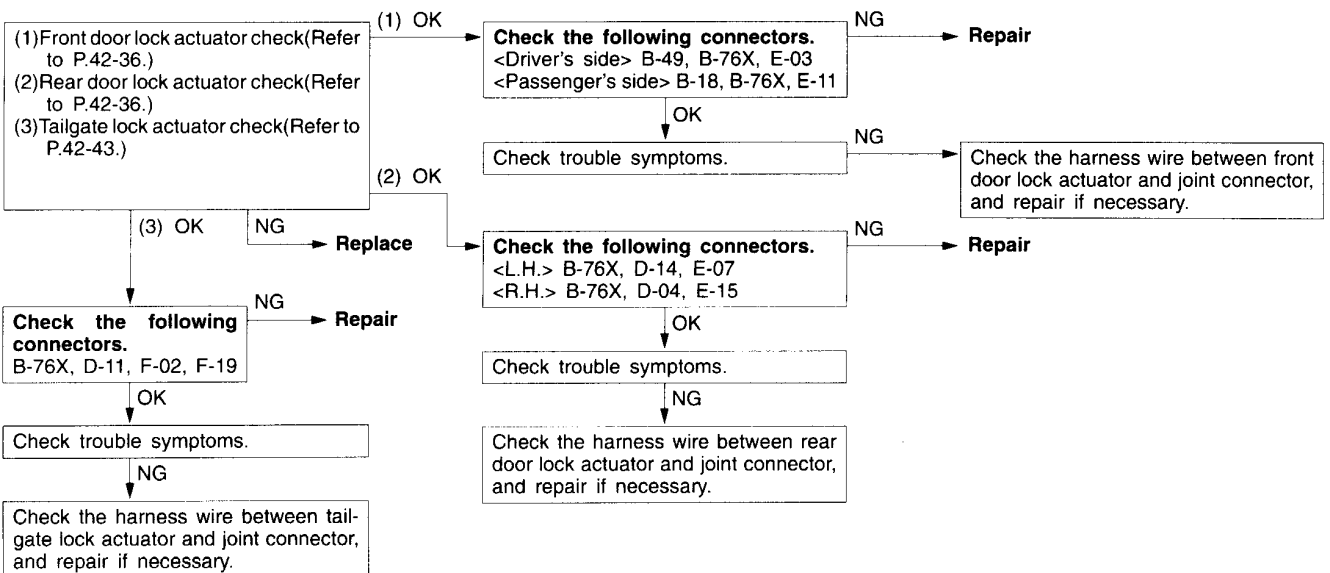

Inspection Procedure 14

None of the door lock functions operate.(The keyless entry system does not operate,either.)	Probable cause
Power circuit system or earth circuit system of the keyless entry receiver ECU may be defective.	<ul style="list-style-type: none"> ● Malfunction of keyless entry receiver ECU ● Malfunction of wiring harness or connector

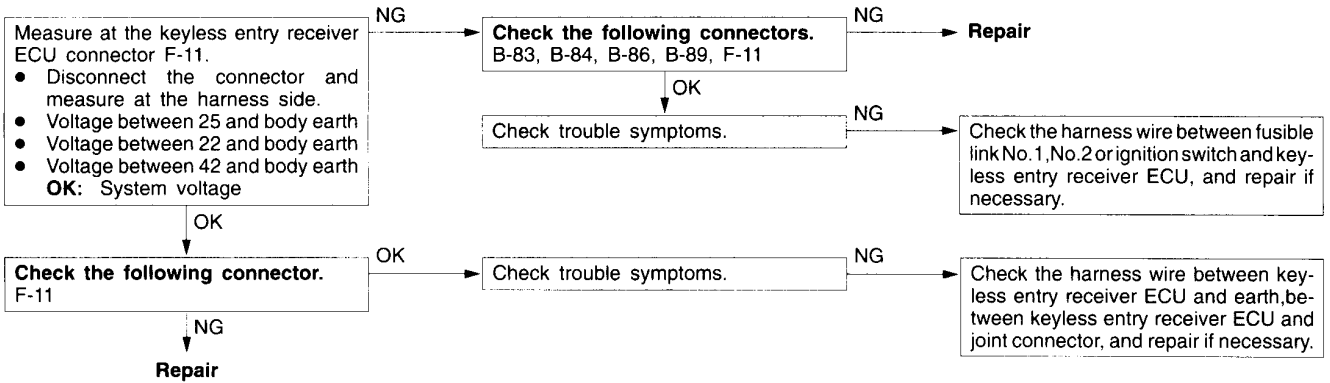

Inspection Procedure 15

The doors do not lock or unlock when the driver's door inside lock knob is operated.	Probable cause
The front door lock actuator(driver's side) or the keyless entry receiver ECU may be defective.	<ul style="list-style-type: none"> ● Malfunction of the front door lock actuator(driver's side) ● Malfunction of the keyless entry receiver ECU ● Malfunction of harness or connector

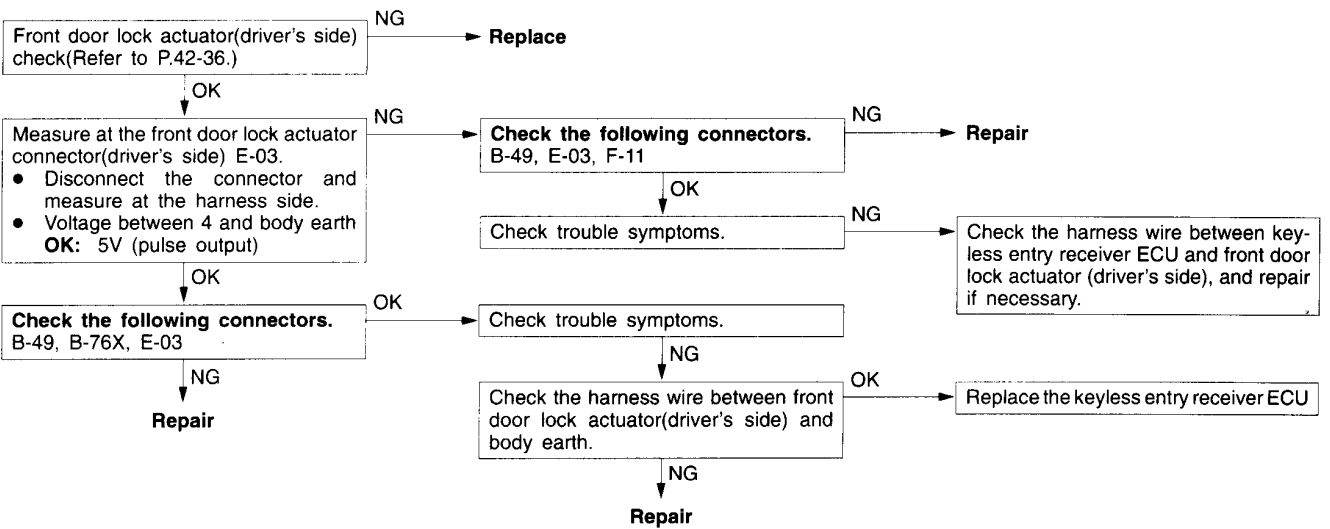

Inspection Procedure 16

The doors do not lock or unlock when the key cylinders are operated.	Probable cause
The keyless entry receiver ECU or the key cylinder switch may be defective.	<ul style="list-style-type: none"> • Malfunction of the door lock key cylinder switch • Malfunction of the tailgate lock key cylinder switch • Malfunction of the keyless entry receiver ECU • Malfunction of harness or connector

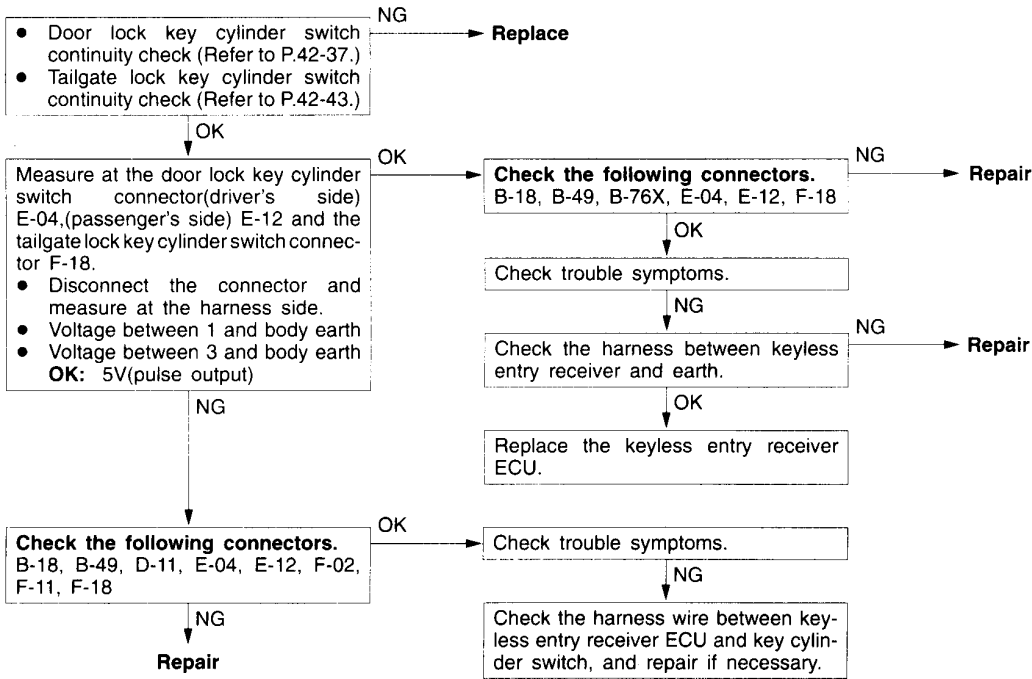

Inspection Procedure 17

Some doors do not lock or unlock.	Probable cause
The door lock actuator, a harness or connector may be defective.	<ul style="list-style-type: none"> • Malfunction of door lock actuator • Malfunction of wiring harness or connector

INSPECTION PROCEDURE 13 FOR TROUBLE SYMPTOMS(Refer to P.42-23.)

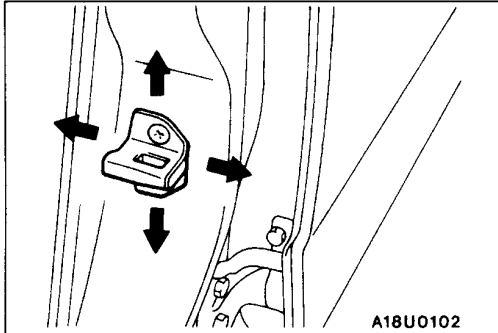
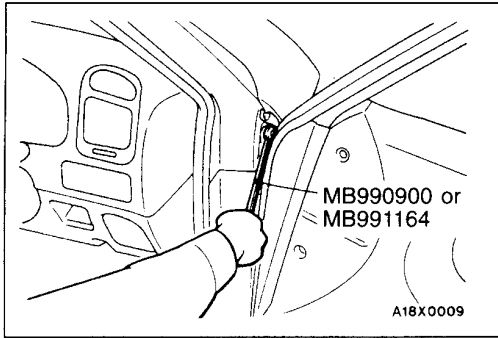

ON-VEHICLE SERVICE

42300090043

DOOR FIT ADJUSTMENT

1. If the clearance between the door and the vehicle body is uneven, affix protective tape to the fender around the hinge and to the edge of the door. Then use the special tool to loosen the door hinge mounting bolts on the body, and adjust the clearance around the door so that it becomes even.
2. If the door and the body are not flush with each other, use the special tool to loosen the door hinge mounting bolts. Then align the door.
3. If the striker and latch do not mesh properly, adjust the position of the striker.

ADJUSTMENT AND REPLACEMENT WHEN THERE IS A MALFUNCTION OF THE POWER WINDOW

42900190017

If the window glass automatically starts moving downwards at the wrong time while it is being raised, carry out the following adjustment or replacement procedures.

1. Remove the door trim and waterproof film. (Refer to P.42-30.)
2. Remove the window regulator assembly from the door window glaze, and then raise and lower the door window glass by hand to check the operation force.
3. If the door window glaze does not move up and down smoothly, repair the twisting in the door sash, or adjust the sash span by loosening the lower sash or center sash mounting bolts and pushing apart the lower sash or center sash while tightening the bolts again. If repair or adjustment is not possible, replace the door assembly.

NOTE

The lower sash cannot normally be adjusted, but it may be possible to adjust it slightly within the range by manufacturing tolerances.

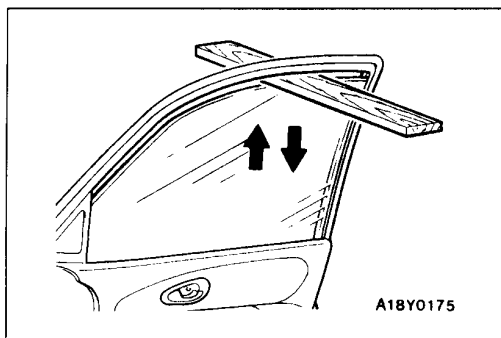
**POWER WINDOW SAFETY MECHANISM CHECK**

42900100034

1. Lower the window glass by 50 mm or less from the fully-closed position.
2. Place a wooden board with a thickness of 4 mm or less as shown in the illustration and then close the window glass.
3. Check that the window glass lowers by approximately 50 mm after it clamps the wooden board.
4. Lower the window glass by 50 mm or more from the fully-closed position and repeat the test given in step 2. above. Check that the window glass lowers by approximately 150 mm at this time.
5. If the window operation is not correct, replace the power window regulator assembly.

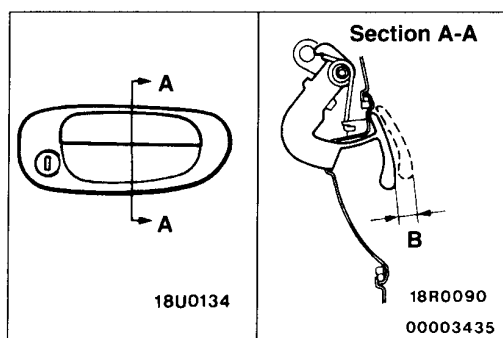
**DOOR OUTSIDE HANDLE PLAY CHECK**

42300160034

1. Check that the door outside handle play is within the standard value range.

Standard value (B): FRONT DOOR 3.7–4.7 mm
REAR DOOR 2.9–4.9 mm

2. If the door outside handle play is not within the standard value range, check the door outside handle or the door latch assembly. Replace, if necessary.

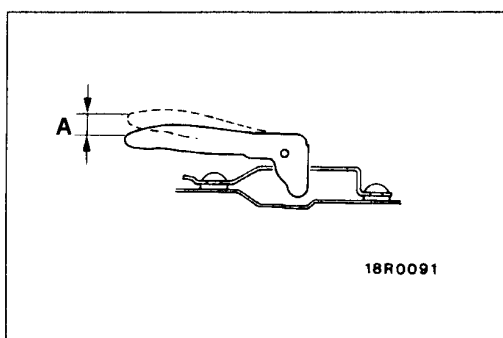
**DOOR INSIDE HANDLE PLAY CHECK**

42300150031

1. Check that the door inside handle play is within the standard value range.

Standard value (A): FRONT DOOR 20.5–22.5 mm
REAR DOOR 14.2–15.2 mm

2. If the door inside handle play is not within the standard value range, check the door inside handle or the door latch assembly. Replace, if necessary.

POWER WINDOW INITIAL SETTING

42900200017

For all doors, after fully raising the window glass, continuously push the power window switch to the UP side for 1 second or more.

DOOR ASSEMBLY

REMOVAL AND INSTALLATION

Post-installation Operation

- Door Adjustment (Refer to P.42-26.)

Front door

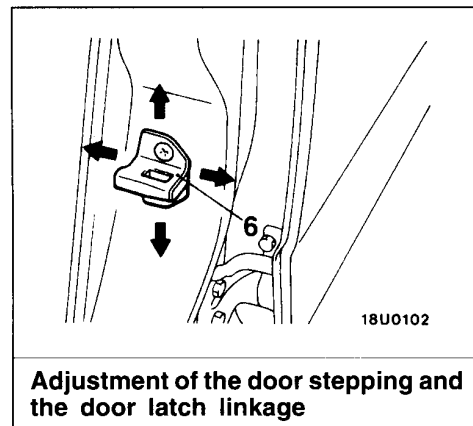
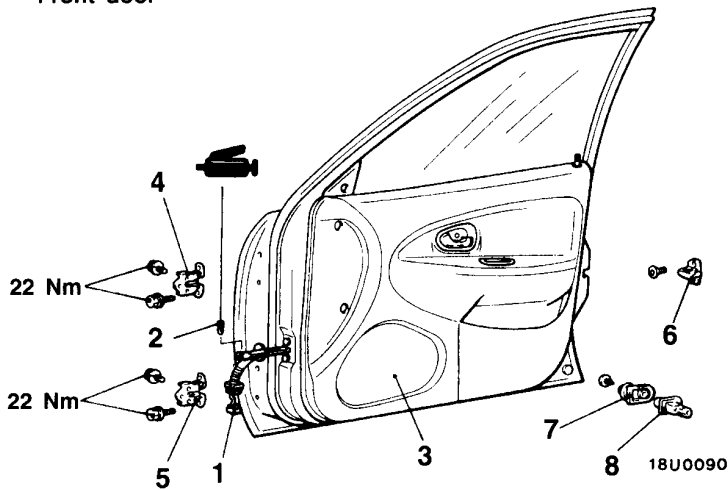

Rear door

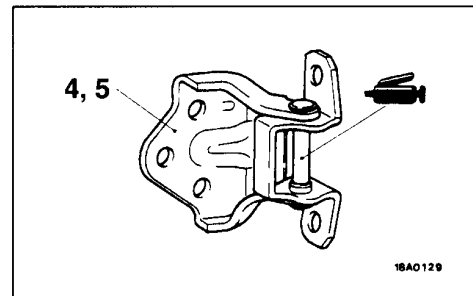
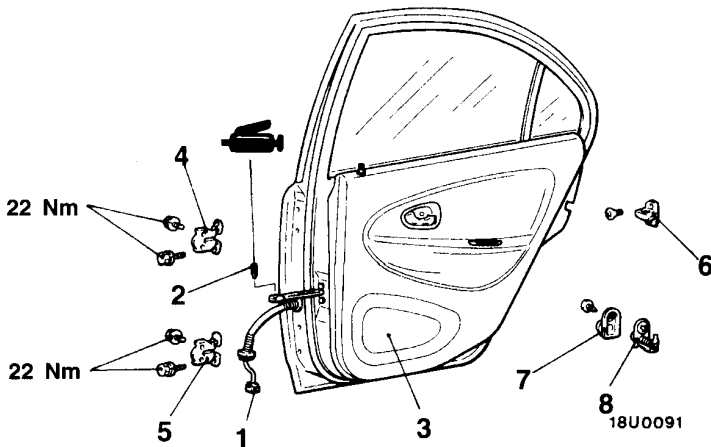

00003436

Door assembly removal steps

1. Harness connector
2. Spring pin
3. Door assembly
4. Door upper hinge
5. Door lower hinge

Striker removal

6. Striker

Door switch removal steps

7. Door switch cap
8. Door switch

42300600031

INSPECTION

DOOR SWITCH CONTINUITY CHECK

Driver's door switch

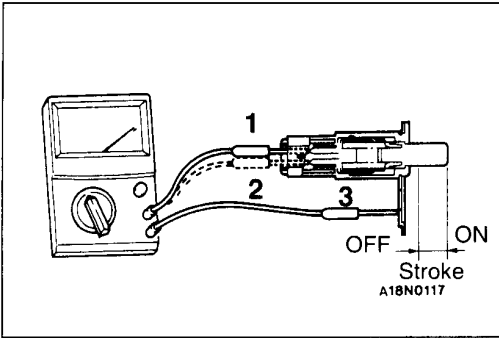

Switch position	Terminal No.		
	1	2	3
Open (ON)	○	○	○
Depressed (OFF)			

Passenger's door and rear door switch

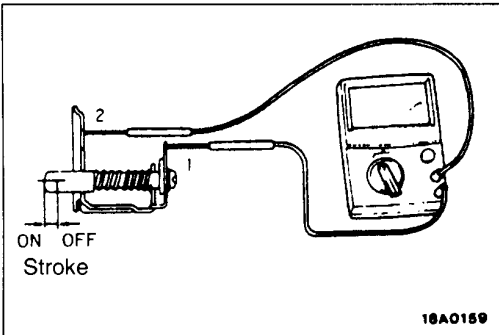

Switch position	Terminal No.	
	1	2
Open (ON)	○	○
Depressed (OFF)		

18A0159

DOOR TRIM AND WATERPROOF FILM REMOVAL AND INSTALLATION

Front door

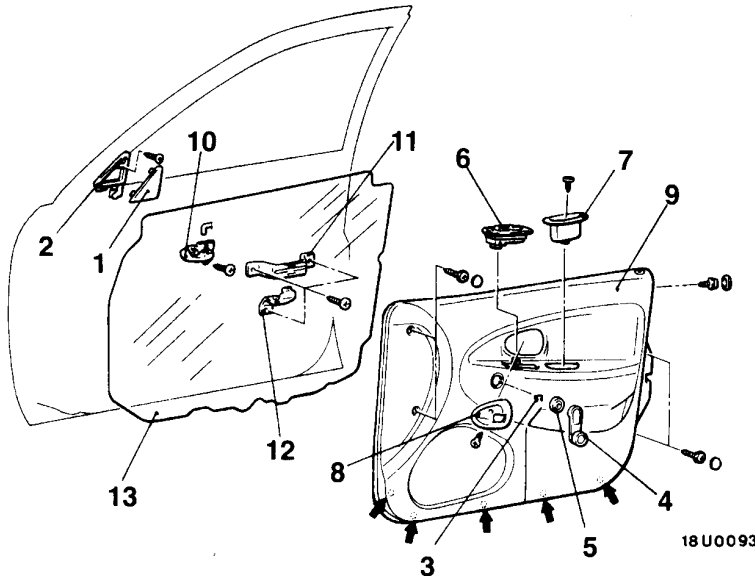

Rear door

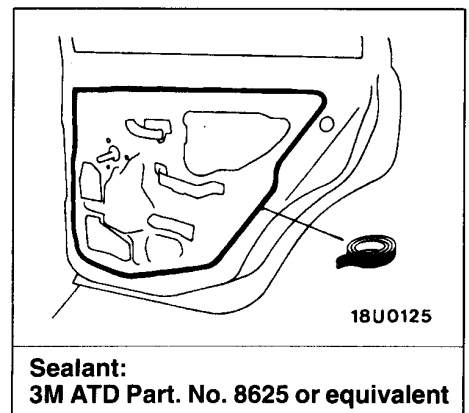
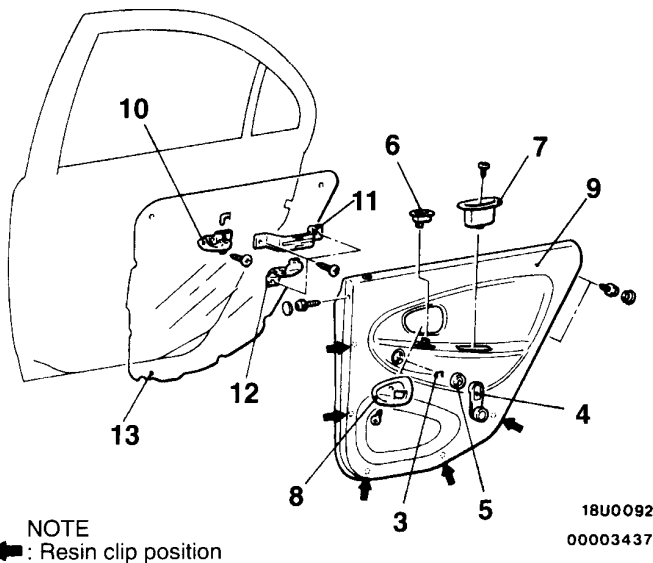

NOTE
← : Resin clip position

Removal steps

1. Delta cover inner lid
2. Delta cover inner frame
3. Clip <Vehicles without power window>
4. Regulator handle <Vehicles without power window>
5. Escutcheon <Vehicles without power window>
6. Power window switch <Vehicles with power window>
7. Pull handle box
8. Cover

9. Door trim
10. Door inside handle
11. Pull handle bracket A
12. Pull handle bracket B
13. Waterproof film



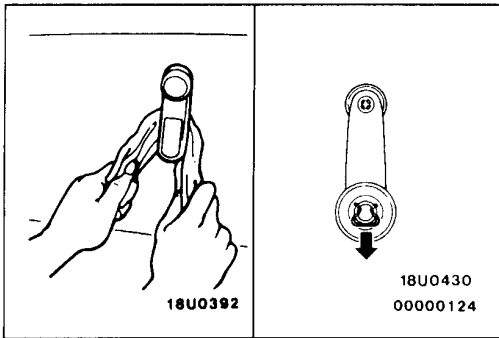

REMOVAL SERVICE POINT

◀A▶ CLIP REMOVAL

Remove the clip by using a rag, and then remove the regulator handle.

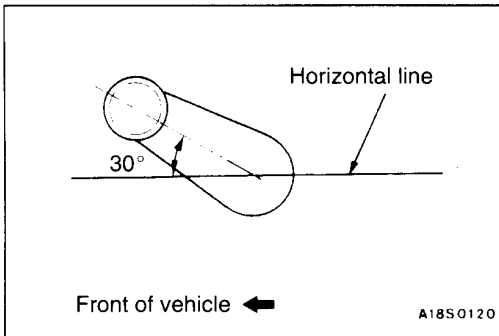

INSTALLATION SERVICE POINT

▶A◀ REGULATOR HANDLE INSTALLATION

1. Install the escutcheon and the clip to the regulator handle.
2. Fully close the front door glass, and install the regulator handle so that it faces as shown in the illustration.

DOOR GLASS AND REGULATOR REMOVAL AND INSTALLATION

Pre-removal and Post-installation Operation
 • Door Trim and Waterproof Film Removal and Installation (Refer to P.42-30.)

Front door

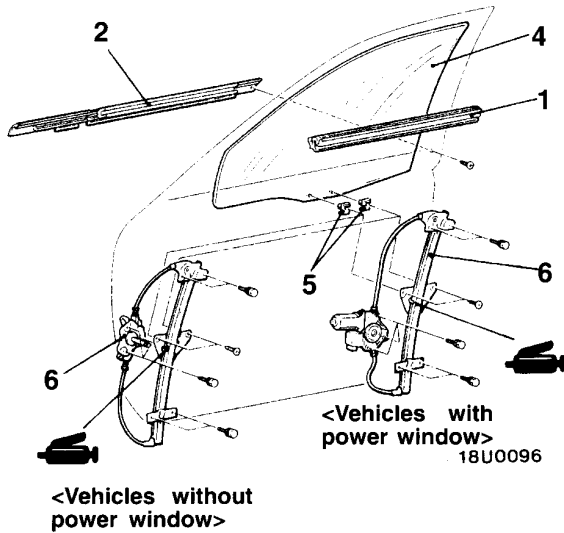

Rear door

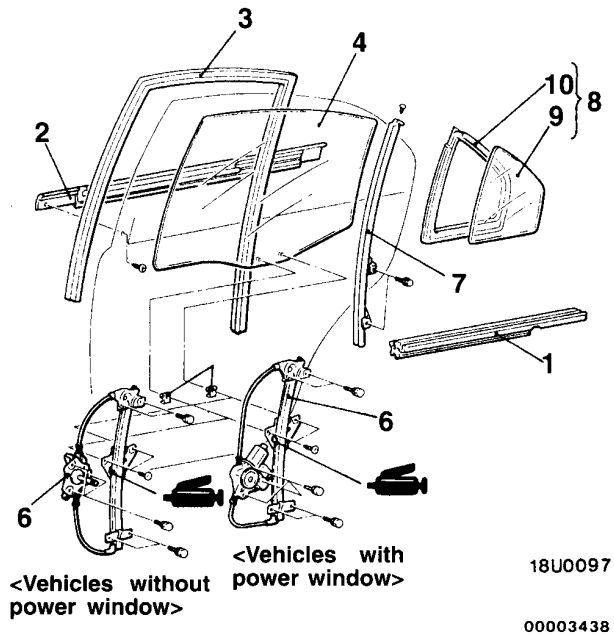

Front window regulator assembly removal steps

1. Door belt line inner weatherstrip
2. Belt line outer weatherstrip
4. Door window glass
5. Door glass holder
6. Window regulator assembly

Rear window regulator assembly removal steps

1. Door belt line inner weatherstrip
2. Belt line outer weatherstrip
3. Door window glass runchannel
4. Door window glass
5. Door window glass holder
6. Window regulator assembly

Stationary window glass removal steps

1. Door belt line inner weatherstrip
2. Belt line outer weatherstrip
3. Door window glass runchannel
4. Door window glass
7. Door centre sash
8. Stationary window glass and weatherstrip assembly
9. Stationary window glass
10. Stationary window weatherstrip



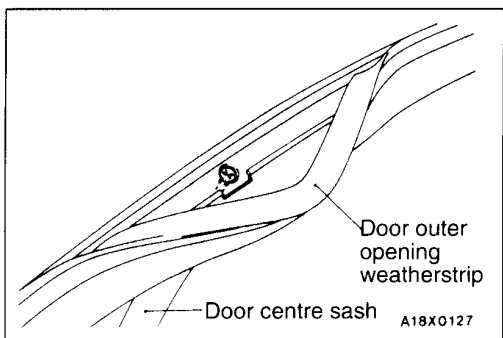

REMOVAL SERVICE POINT

◀A▶ DOOR CENTRE SASH REMOVAL

Remove the portion of the door outer opening weatherstrip which is shown in the illustration and remove the door centre sash mounting screw.

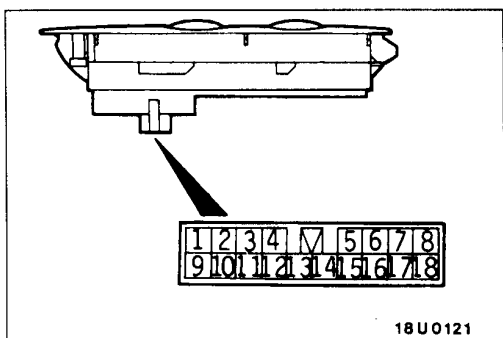

INSPECTION

42900160032

POWER WINDOW MAIN SWITCH CHECK

1. Operate the switch, and check the continuity between terminals.

Window lock switch	Switch position	Terminal No.															
		Front (L.H.)				Front (R.H.)				Rear (L.H.)				Rear (R.H.)			
		1	5	14	15	2	6	14	16	3	7	14	17	4	8	14	18
Normal	UP		○	○			○	○			○	○			○	○	
	AUTO UP	○	○	○		○	○	○		○	○	○		○	○	○	
	DOWN			○	○			○	○			○	○			○	○
	AUTO DOWN	○	○	○	○	○	○	○	○	○	○	○	○	○	○	○	○
LOCK	UP										○	○			○	○	
	AUTO UP	○	○			○	○			○	○	○		○	○	○	
	DOWN											○	○			○	○
	AUTO DOWN	○	○	○	○	○	○	○	○	○	○	○	○	○	○	○	○

2. Apply battery voltage to terminal 10, and connect terminal 12 to earth.

3. Move the window lock switch to the normal position, and then measure the voltage at terminal (14) under the measurement conditions given below.

Measurement condition	Voltage
Apply battery voltage to terminal 9	Battery voltage
Remove voltage from terminal (9).	Battery voltage (for 30 seconds after voltage is removed) → 0 V
Earth terminal (11) within 30 seconds after voltage is removed from terminal (9).	Battery voltage (for 30 seconds after earthing) → 0 V
Disconnect earth from terminal (11) within 30 seconds after earthing it.	0V

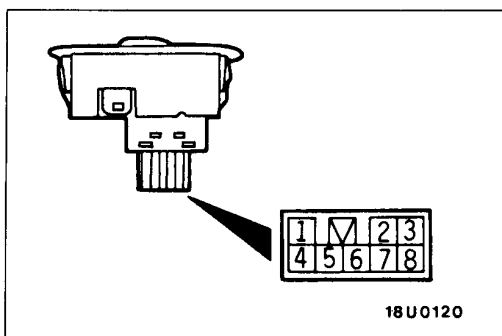

POWER WINDOW SUB-SWITCH CONTINUITY CHECK

Switch position	Terminal No.							
	1	2	3	4	6	7	8	
UP			○		○		○	
AUTO UP	○		○	○	○		○	
OFF	○			○				
		○				○		
			○				○	
DOWN		○			○	○		
AUTO DOWN	○	○		○	○	○		

42300460042

DOOR HANDLE AND LATCH REMOVAL AND INSTALLATION

Pre-removal Operation

- Door Trim Removal (Refer to P.42-30.)

Post-installation Operation

- (1) Door Inside Handle Play Check (Refer to P.42-27.)
- (2) Door Trim Installation (Refer to P.42-30.)
- (3) Door Fit Adjustment (Refer to P.42-26.)

Front door

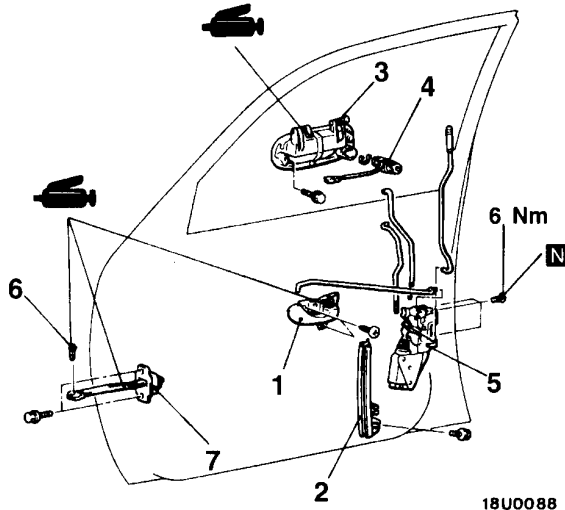

18U0088

Rear door

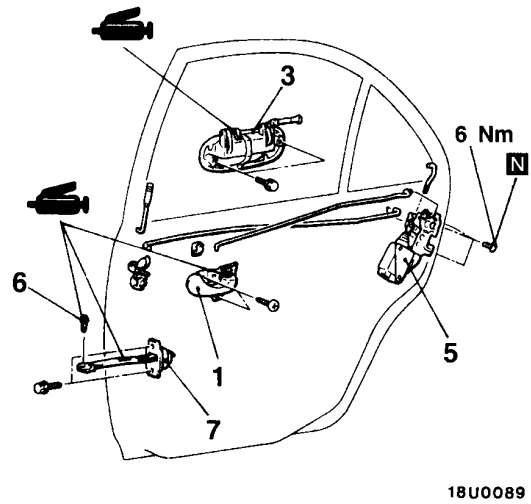

18U0089

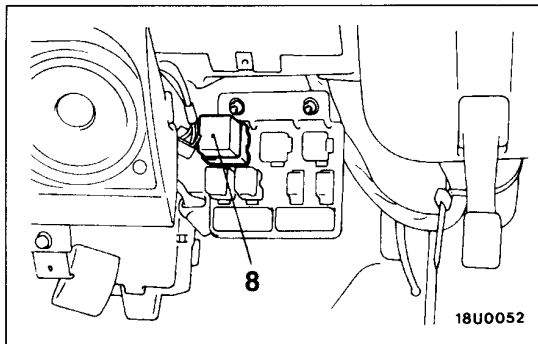

18U0052

00003439

Front door handle and door latch assembly removal steps

1. Door inside handle
- Waterproof film (Refer to P.42-30.)
2. Lower sash rear
3. Door outside handle
4. Door lock key cylinder
5. Door latch assembly

Rear door handle and door latch assembly removal steps

1. Door inside handle
- Waterproof film (Refer to P.42-30.)
3. Door outside handle
5. Door latch assembly

Door check removal steps

1. Door inside handle
- Waterproof film (Refer to P.42-30.)
6. Spring pin
7. Door check



Door lock ECU removal

8. Door lock ECU
<Vehicles with central door locking system (except vehicles keyless entry system)>

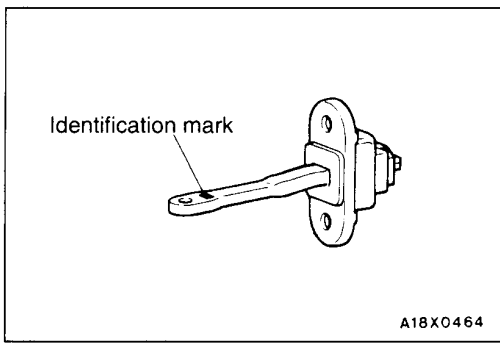

INSTALLATION SERVICE POINT

▶A◀ DOOR CHECK INSTALLATION

Install the door check so that the identification mark faces upwards.

Applicable location		Identification mark
L.H.	Front door	FL
	Rear door	RL
R.H.	Front door	FR
	Rear door	RR

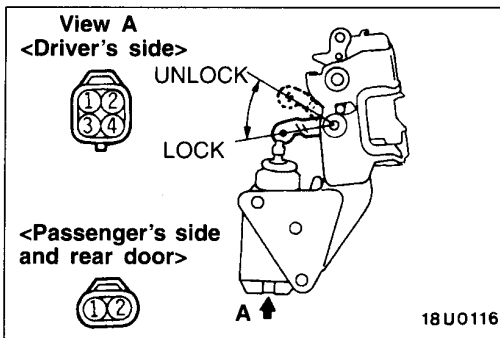

INSPECTION

42300610034

DOOR LOCK ACTUATOR CHECK

<Driver's side>

Rod position	Terminal No.				Rod operation
	1	2	3	4	
LOCK	⊕	⊖			LOCK position → UNLOCK position
UNLOCK	⊖	⊕			UNLOCK position → LOCK position
LOCK					
UNLOCK			○	○	

<Passenger's side and rear door>

Rod position	Terminal No.		Rod operation
	1	2	
LOCK	⊕	⊖	LOCK position → UNLOCK position
UNLOCK	⊖	⊕	UNLOCK position → LOCK position

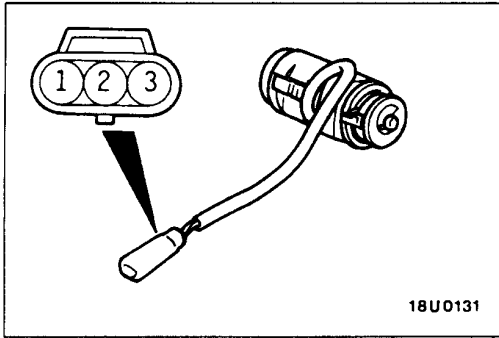

DOOR LOCK KEY CYLINDER SWITCH CONTINUITY CHECK

42300630030

<L.H.>

Switch position	Terminal No.		
	1	2	3
LOCK		○ — ○	○ — ○
Neutral (OFF)			
UNLOCK	○ — ○		

<R.H.>

Switch position	Terminal No.		
	1	2	3
LOCK	○ — ○		
Neutral (OFF)			
UNLOCK		○ — ○	○ — ○

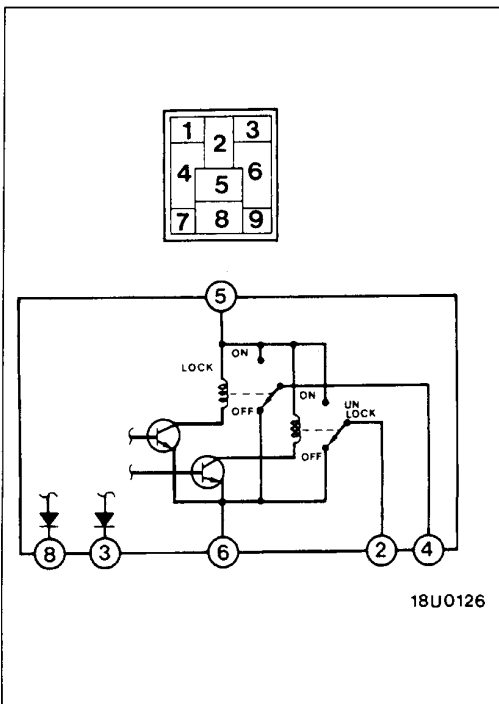

DOOR LOCK ECU CHECK

42300650029

1. Apply battery voltage to terminal 5, and connect terminal 6 to earth.
2. Use a needle-type multimeter to measure the voltage under the measurement conditions given below.

Measurement condition	Terminal No.	
	2	4
Connect terminal (8) to earth.	Needle swings at the point when terminal is earthed.	0V
Disconnect earth from terminal (8).	0V	Needle swings at the point when earth is disconnected.
Connect terminal (3) to earth.	0V	Needle swings at the point when terminal is earthed.

3. Check the continuity between terminals 2, 4, 6.

WINDOW GLASS RUNCHANNEL AND DOOR OPENING WEATHERSTRIP

42300310040

REMOVAL AND INSTALLATION

Front door

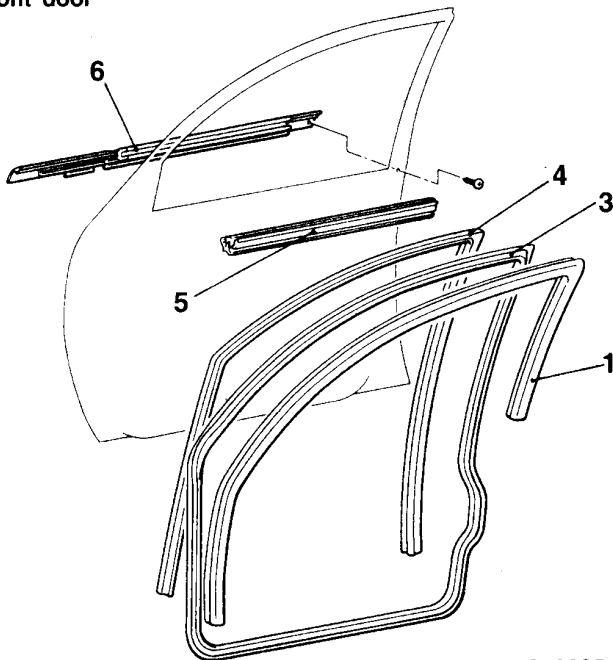

18U0095

Rear door

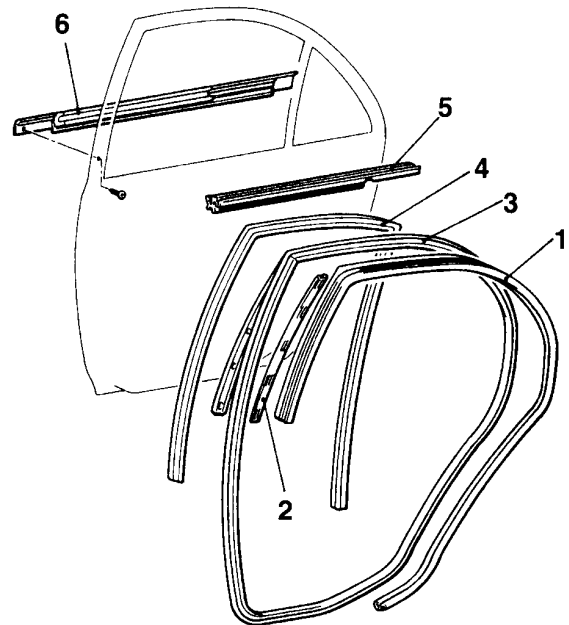

18U0094

00003440

Door inner opening weatherstrip removal steps

- Centre pillar lower trim (Refer to GROUP 52A.)
 - Front scuff plate (Refer to GROUP 52A – Trims.)
 - Rear scuff plate (Refer to GROUP 52A – Trims.)
1. Door inner opening weatherstrip

Door outer opening weatherstrip removal

2. Weatherstrip retainer
3. Door outer opening weatherstrip



Window glass runchannel removal

4. Window glass runchannel

Door beltline inner weatherstrip removal steps

- Door trim (Refer to P.42-30.)
5. Door beltline inner weatherstrip

Door beltline outer weatherstrip removal steps

- Delta cover outer (Refer to GROUP 51 – Door Mirror.)
6. Door beltline outer weatherstrip

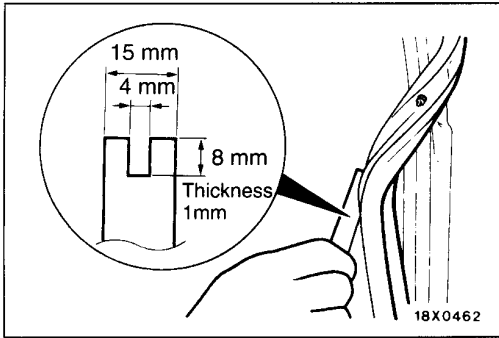

REMOVAL SERVICE POINT

◀A▶ DOOR OUTER OPENING WEATHERSTRIP REMOVAL

Make a tool as shown in the illustration to remove the door opening weatherstrip.

INSTALLATION SERVICE POINT

▶A◀ DOOR OUTER OPENING WEATHERSTRIP INSTALLATION

The clip colour identifies the left and right weatherstrips, so be sure to use the colours so as to install correctly.

Applicable side	Identification colour
Left door	Green
Right door	Red

TAILGATE

4240060016

SPECIAL TOOL

Tool	Number	Name	Use
	MB990784	Ornament remover	Removal of the tailgate trim

TROUBLESHOOTING

4240070019

INSPECTION CHART FOR TROUBLE SYMPTOMS

Trouble symptom	Reference page
Door lock mechanism does operate.	42-14.

**TAILGATE ASSEMBLY
REMOVAL AND INSTALLATION**

42400110025

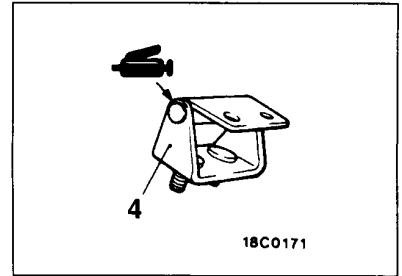
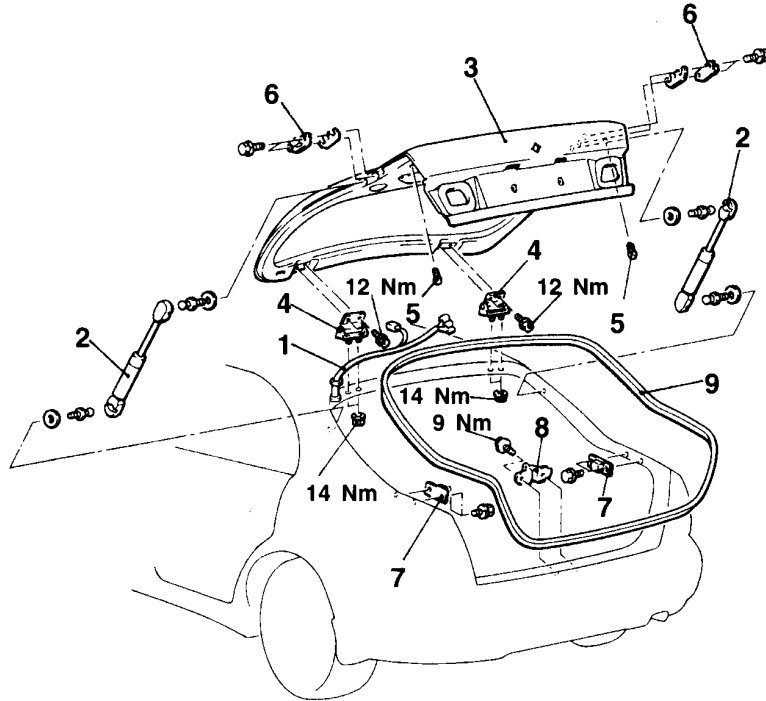

18U0081

00003441

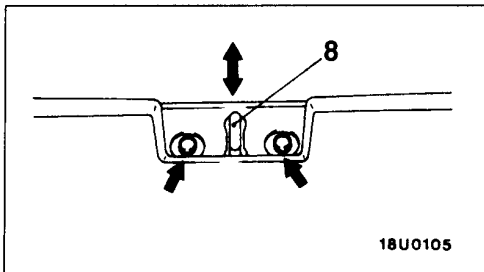

Adjustment of tailgate step and tailgate striker linkage

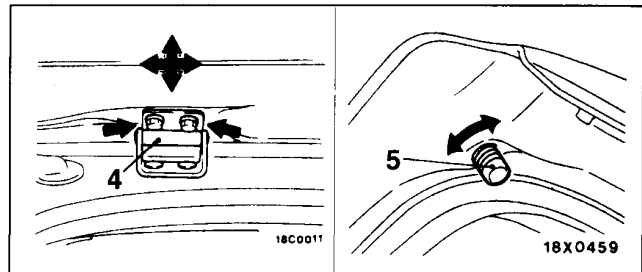

Adjustment of clearance around tailgate

Tailgate and tailgate hinge removal steps

- Tailgate trim (Refer to P.42-42.)
- Rear fog lamp
- License plate lamp
- 1. Harness connection
- 2. Tailgate gas spring
- 3. Tailgate assembly
- Rear roof rail trim (Refer to GROUP 52A.)
- 4. Tailgate hinge
- 5. Bumper
- 6. Damper upper
- 7. Damper lower

◀A▶

▶B◀

Tailgate striker removal steps

- Rear end trim (Refer to GROUP 52A.)
- 8. Tailgate striker

Tailgate opening weatherstrip removal

▶A◀

- 9. Tailgate opening weatherstrip

REMOVAL SERVICE POINT**◀A▶ TAILGATE GAS SPRING REMOVAL****Caution**

1. Never try to disassemble the tailgate gas spring or burn it.
2. Always bore a hole in the tailgate gas spring to release the interior gas before the gas spring is discarded.

INSTALLATION SERVICE POINTS**▶A◀ TAILGATE OPENING WEATHERSTRIP INSTALLATION**

Install the tailgate opening weatherstrip so that the joint is at the centre of the body.

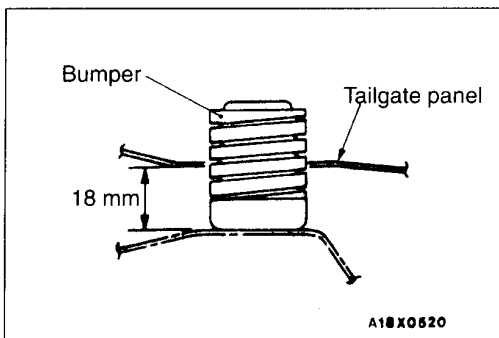
**▶B◀ BUMPER INSTALLATION**

Install the bumper so that the amount of projection from the tailgate panel is as shown in the illustration.

TAILGATE TRIM

42400140017

REMOVAL AND INSTALLATION

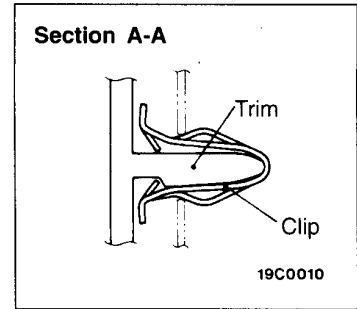
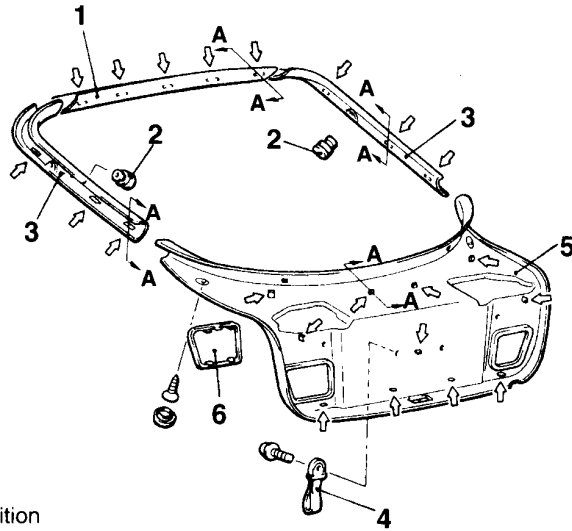

NOTE
 ← : metal clip position

18U0083

00003442

Removal steps

1. Tailgate upper trim
2. Tailgate trim hook
3. Tailgate side trim

4. Pull down strap assembly
5. Tailgate lower trim
6. Lid

TAILGATE LATCH

42400170016

REMOVAL AND INSTALLATION

Pre-removal and Post-installation Operation

- Tailgate Lower Trim Removal and Installation (Refer to P.42-42.)

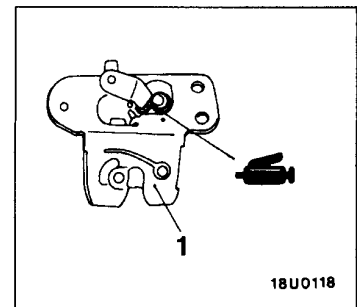
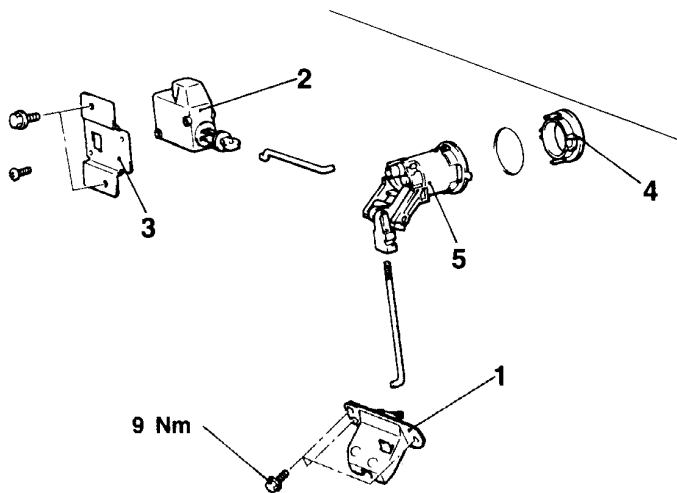

18U0111

00003443

Removal steps

1. Tailgate latch
2. Tailgate lock actuator
3. Tailgate lock actuator bracket

4. Tailgate cylinder cap
5. Tailgate lock cylinder

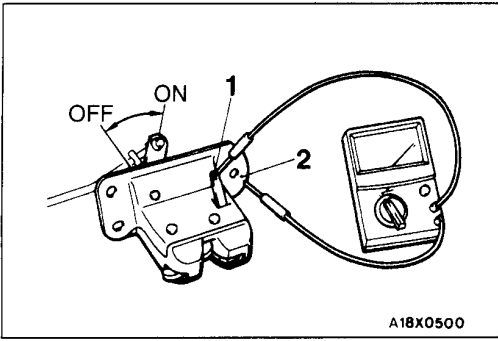

INSPECTION

42400190036

TAILGATE SWITCH CONTINUITY CHECK

Switch position	Terminal No.	
	1	2
ON (Latch open)	○ — ○	○ — ○
OFF (Latch shut)		

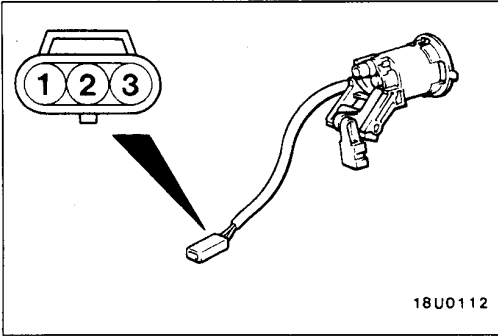

TAILGATE LOCK KEY CYLINDER SWITCH CONTINUITY CHECK

42400200029

Switch position	Terminal No.		
	1	2	3
LOCK	○ — ○	○ — ○	
Neutral (OFF)			
UNLOCK		○ — ○	○ — ○

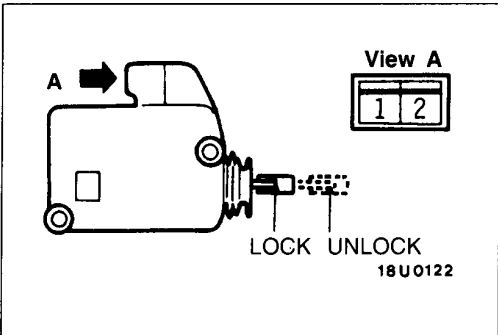

TAILGATE LOCK ACTUATOR CHECK





42400210015

Rod position	Terminal No.		Rod operation
	1	2	
LOCK	⊕ — ⊖	⊖ — ⊕	LOCK position → UNLOCK position
UNLOCK	⊖ — ⊕	⊕ — ⊖	UNLOCK position → LOCK position

KEYLESS ENTRY SYSTEM

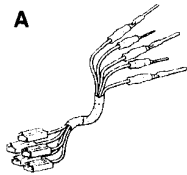
42800060018

SPECIAL TOOLS

Tool	Number	Name	Use
<p>A</p>  <p>B</p>  <p>C</p>  <p>D</p> 	MB991223	Harness set	Measurement of terminal voltage
	A: MB991219	A: Test harness	A: Connector pin contact pressure inspection
	B: MB991220	B: LED harness	B, C: Power circuit inspection
	C: MB991221	C: LED harness adapter	D: Commercial tester connection
	D: MB991222	D: Probe	

TROUBLESHOOTING

42800180011

INSPECTION CHART FOR TROUBLE SYMPTOMS

Trouble symptoms	Inspection procedure	Reference page
Keyless entry system	None of the doors, including the tailgate, can be locked or unlocked. (However, the central door locking system is functioning normally.)	1 42-45
	All of the doors, including the tailgate, can be locked and unlocked, but the hazard lamp does not illuminate or does not flash. (However, the hazard lamp flashes normally when the hazard lamp switch is used.)	2 42-45
	Secret codes cannot be registered.	3 42-46
Theft-alarm system	The security indicator lamp does not flash after the system has been set. (However, the central door locking system and keyless entry system are functioning normally.)	4 42-47
	The security indicator lamp keeps flashing even after the theft-alarm system has been disarmed. (However, the central door locking system and keyless entry system are functioning normally.)	5 42-47

Trouble symptoms		Inspection procedure	Reference page
Theft-alarm system	The horn does not sound after the hood switch, door switch or tailgate switch turns on, even though the theft-alarm system has been armed.	6	42-48
	The hazard lamp does not flash after the hood switch, door switch or tailgate switch turns on, even though the theft-alarm system has been armed. (However, the hazard lamp flashes normally when the hazard lamp switch is used.)	7	42-49

INSPECTION PROCEDURE FOR TROUBLE SYMPTOMS

Inspection Procedure 1

None of the doors, including the tailgate, can be locked or unlocked. (However, the central door locking system is functioning normally.)	Probable cause
The transmitter battery may be spent, the secret code may not have been registered correctly, or there may be a malfunction of the transmitter. If the transmitter is normal, the cause is probably a malfunction of the keyless entry receiver-ECU.	<ul style="list-style-type: none"> • Malfunction of the battery • Malfunction of the transmitter • Malfunction of the keyless entry receiver ECU

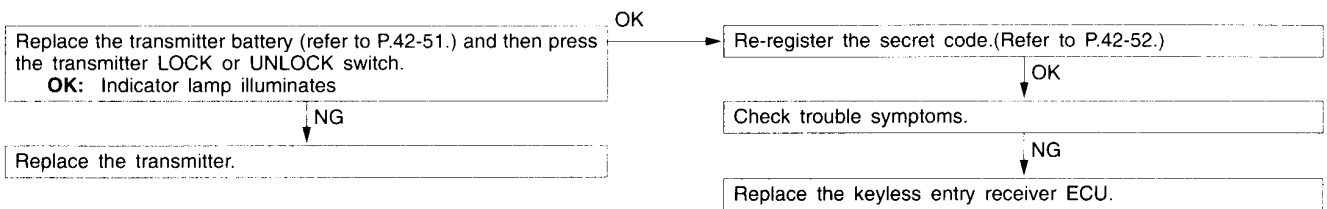

Inspection Procedure 2

All of the doors, including the tailgate, can be locked and unlocked, but the hazard lamp does not illuminate or does not flash. (However, the hazard lamp flashes normally when the hazard lamp switch is used.)	Probable cause
The keyless entry receiver ECU or the harness between hazard lamp and keyless entry receiver ECU may be defective.	<ul style="list-style-type: none"> • Malfunction of the keyless entry receiver ECU • Malfunction of harness or connector

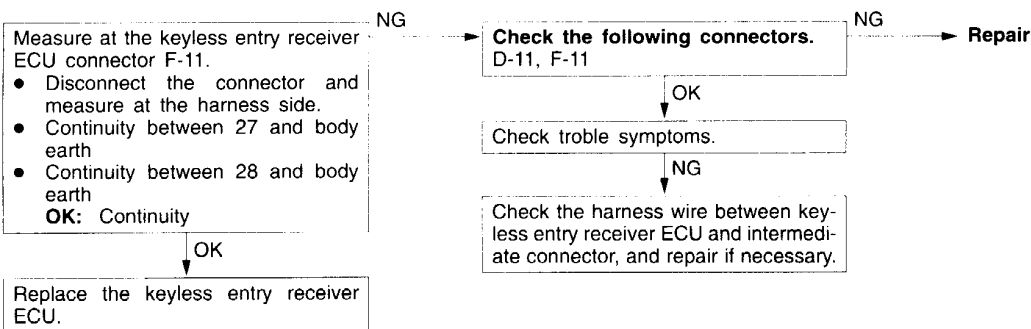

Inspection Procedure 3

Secret codes cannot be registered.	Probable cause
One of the following items may be defective. Diagnosis connector Keyless entry receiver ECU power supply circuit Earth circuit Diagnosis output circuit	<ul style="list-style-type: none"> ● Malfunction of the keyless entry receiver ECU ● Malfunction of the MUT-II ● Malfunction of harness or connector

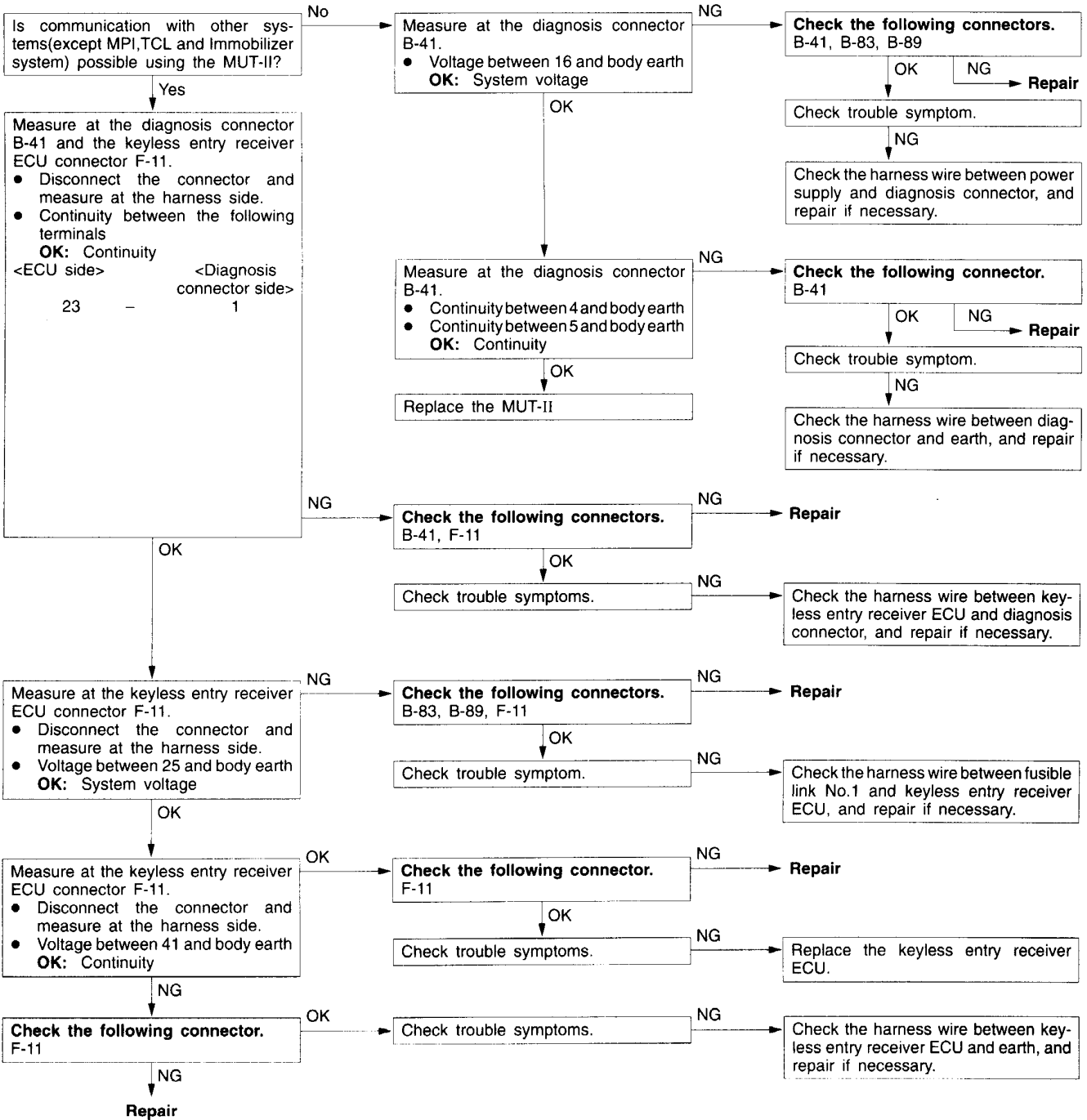

Inspection Procedure 4

<p>The security indicator lamp does not flash after the system has been set. (However, the central door locking system and keyless entry system are functioning normally.)</p>	<p>Probable cause</p>
<p>If the central door locking system and keyless entry system are normal, the cause is probably a blown bulb or a malfunction of the keyless entry receiver-ECU.</p>	<ul style="list-style-type: none"> • Malfunction of the security indicator lamp bulb • Malfunction of the keyless entry receiver ECU • Malfunction of harness or connector

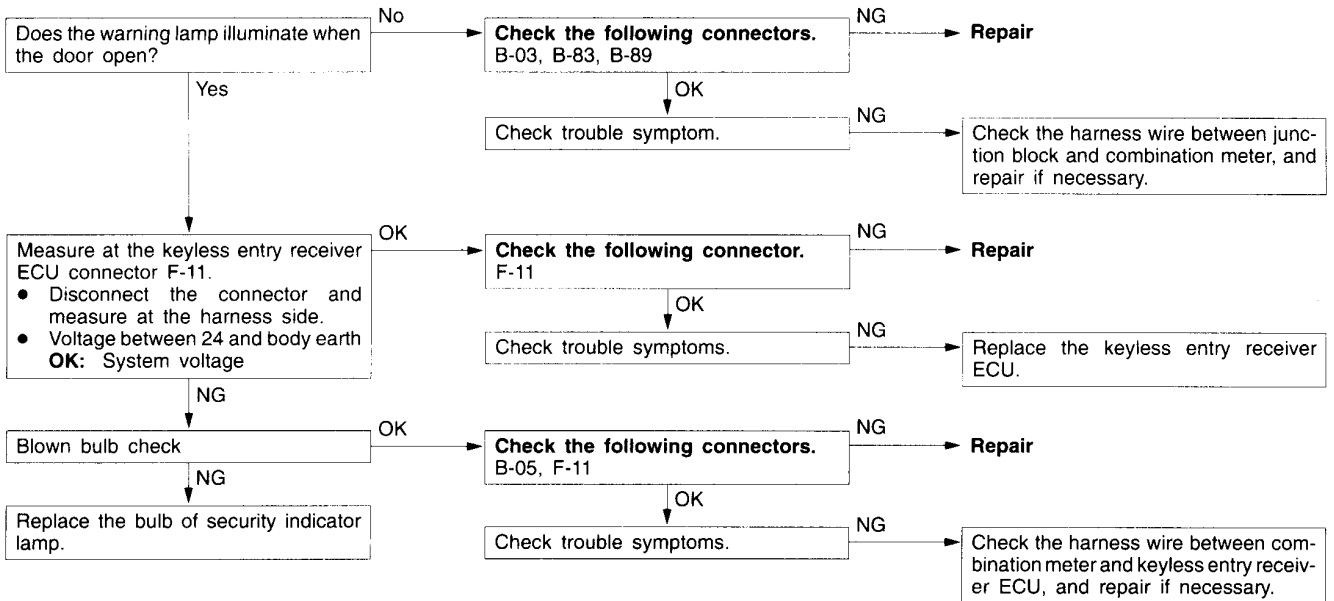

Inspection Procedure 5

<p>The security indicator lamp keeps flashing even after the theft-alarm system has been disarmed. (However, the central door locking system and keyless entry system are functioning normally.)</p>	<p>Probable cause</p>
<p>The keyless entry receiver ECU may be defective.</p>	<ul style="list-style-type: none"> • Malfunction of the keyless entry receiver ECU

Replace the keyless entry receiver ECU.

Inspection Procedure 6

The horn does not sound after the hood switch, door switch or tailgate switch turns on, even though the theft-alarm system has been armed. Probable cause

One of the following items may be defective.
 Hood switch input circuit
 Door switch input circuit
 Tailgate switch input circuit
 Each switch
 Horn
 Horn relay
 Keyless entry receiver ECU

- Malfunction of the hood switch
- Malfunction of the door switch
- Malfunction of the tailgate switch
- Malfunction of the horn
- Malfunction of the horn relay
- Malfunction of the keyless entry receiver ECU
- Malfunction of harness or connector

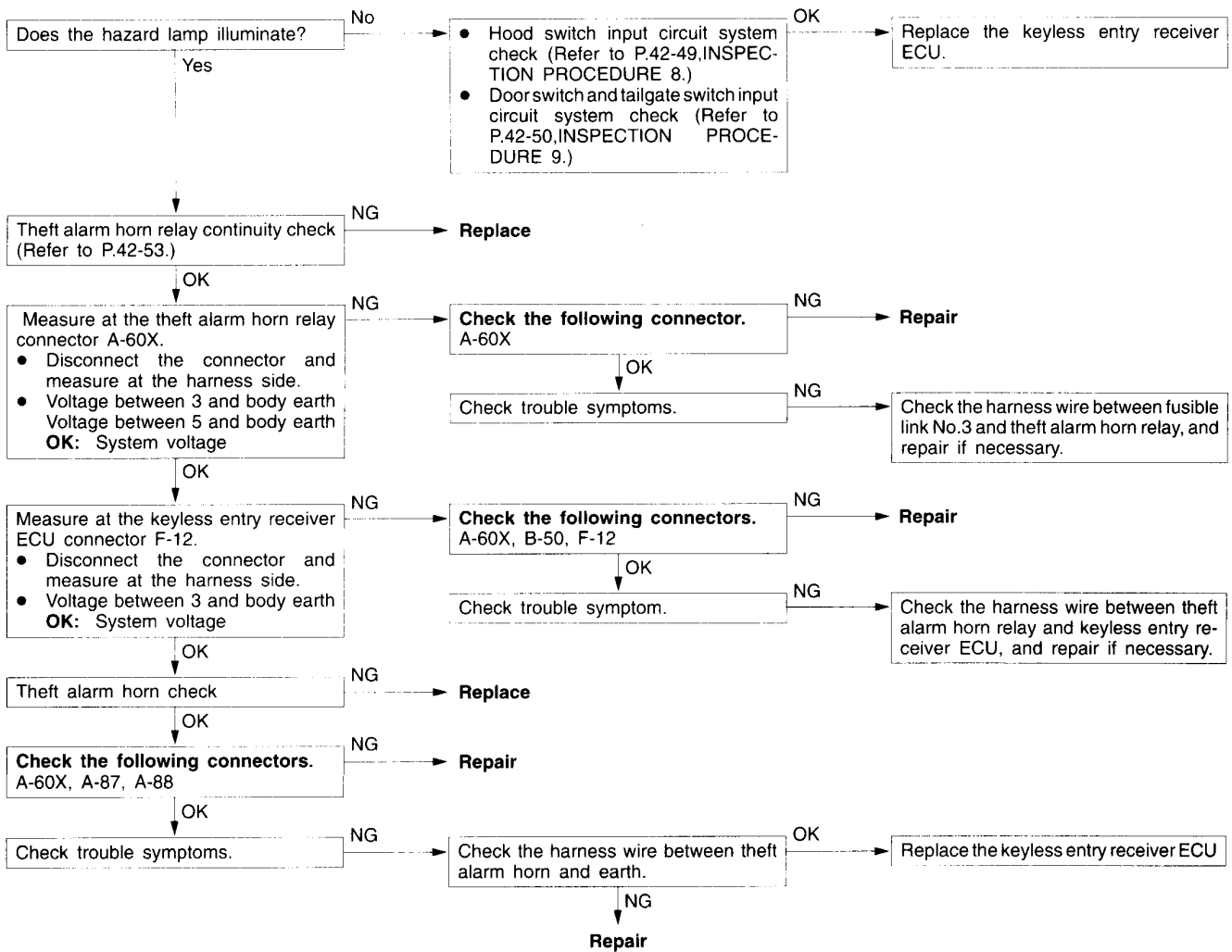

Inspection Procedure 7

<p>The hazard lamp does not flash after the hood switch, door switch or tailgate switch turns on, even though the theft-alarm system has been armed. (However, the hazard lamp flashes normally when the hazard lamp switch is used.)</p>	<p>Probable cause</p>
<p>One of the following items may be defective. Hood switch input circuit Door switch input circuit Tailgate switch input circuit Each switch Keyless entry receiver ECU Harness between hazard lamp and keyless entry receiver ECU</p>	<ul style="list-style-type: none"> • Malfunction of the hood switch • Malfunction of the door switch • Malfunction of the tailgate switch • Malfunction of the keyless entry receiver ECU • Malfunction of the harness or connector

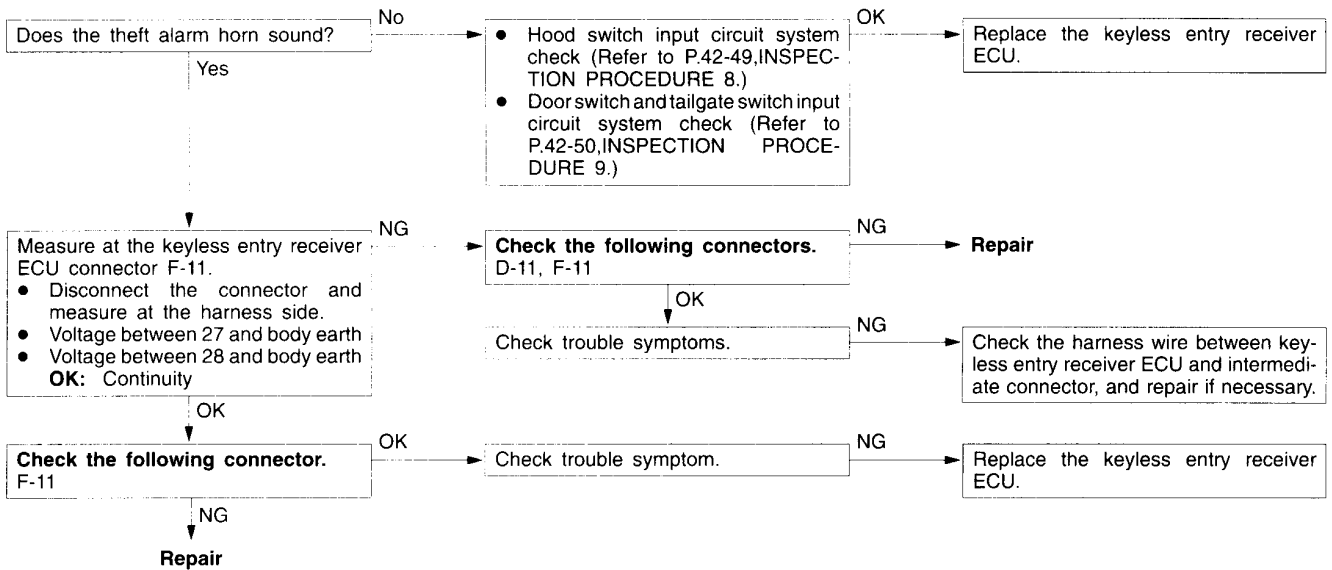

Inspection Procedure 8

Hood switch input circuit system check

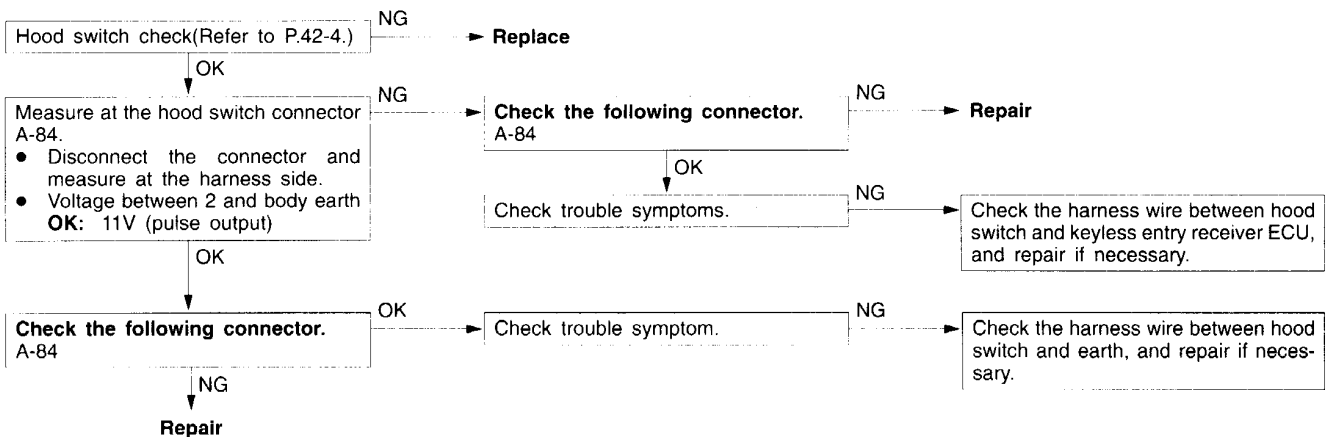

Inspection Procedure 9

Door switch and tailgate switch input circuit system check

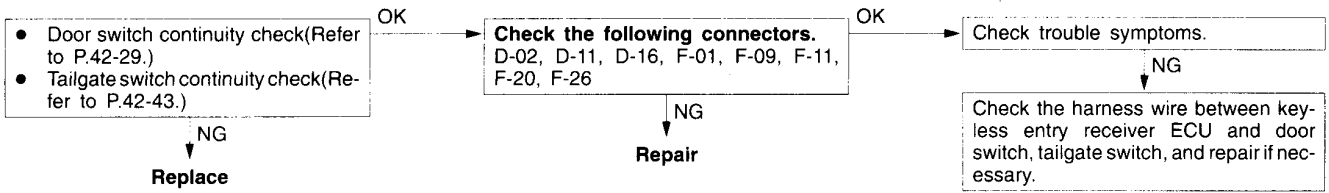

INSPECTION AT KEYLESS ENTRY RECEIVER ECU TERMINALS

42800220010

TERMINAL VOLTAGE CHART

1. Measure the voltages between terminal (41) (earth terminal) and each respective terminal.
2. The terminal arrangements are shown in the illustrations below.

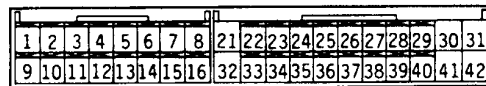

18U0130

Connector Terminal No.	Signal	Checking Requirements	Normal Condition
3	Theft afram horn relay	ON	0V
		OFF	System voltage
11	Hood switch	Hood closed (Hood switch: ON)	0V
		Hood open (Hood switch: OFF)	11V (pulse output)*
21	Door lock output	When operating	System voltage
		When not operating	0V
22	Ignition switch	Ignition switch: ACC or ON	System voltage
		Ignition switch: OFF	0V
23	Diagnostic selection (Input)	MUT-II : Connected	0V
		MUT-II : Disconnected	Apporox. 4V
24	Security indicator lamp	When lamp illuminates	0V*
		When lamp is switched off	System voltage
25, 42	Keyless entry receiver ECU power supply	Always	System voltage
27, 28	Hazard warning lamp	When lamp is switched off	0V
		When lamp illuminates	System voltage

Connector Terminal No.	Signal	Checking Requirements	Normal Condition
30	Door unlock output	When operating	System voltage
		When not operating	0V
34	Door switch or tailgate switch	Some door is open(Switch: ON)	0V
		All doors are closed(Switch: OFF)	11V (pulse output)*
35	Front door lock actuator (driver's side)	LOCK	11V (pulse output)*
		UNLOCK	0V
36	Key cylinder switch	UNLOCK	0V
		NEUTRAL	11V (pulse output)*
37		LOCK	0V
		NEUTRAL	11V (pulse output)*
41	Earth	Always	0V

NOTE

*: Measurements are impossible using a voltmeter, but are possible using an oscilloscope.

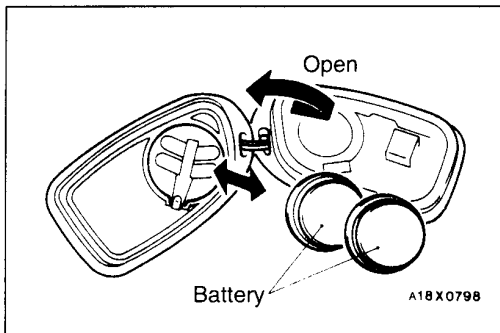

ON-VEHICLE SERVICE

42800090017

BATTERY REPLACEMENT

1. Insert a screwdriver in a slit in the transmitter case and pry it lightly to open the case. Then take the battery out of the transmitter.
2. Install a new battery with its positive side down.

Replacement battery: Lithium battery CR2016 × 2

3. Firmly close the transmitter case.
4. Check that the keyless entry system operates properly.

Caution

When the transmitter is opened, be careful not to allow water, dust, etc. to stick to the transmitter. In addition, do not touch the precision electronic device.

HOW TO REGISTER A SECRET CODE

42800100017

Each transmitter is programmed with an individual secret code.

If the transmitter or receiver is replaced or the secret code is improperly registered, re-register the code into the receiver.

Before registering, check that doors can be properly locked or unlocked by the key.

1. Connect the MUT-II to the diagnosis connector.

NOTE

Terminal (1) of the diagnosis connector will be earthed at this time and the mode will switch to the secret code registration preparation mode.

Caution

Connection and disconnection of the MUT-II should always be carried out with the ignition switch in the OFF position.

2. Close all of the doors.
3. Turn the ignition switch to ACC and then to OFF.

NOTE

The doors will lock and then unlock at this time, and the mode will then switch to the secret code registration mode.

4. Press the desired switch on the transmitter once, and then press it two more times within 10 seconds. The secret code will then be registered.

5. After registration is completed, the doors will lock and then unlock once.

NOTE

If there are two transmitters, register the secret code for the first one, and then within one minute after doing this, register the secret code for the second one by following the same procedure as given above.

6. After registration for the second transmitter has been completed, the doors will lock and then unlock once.
7. The registration mode will be cleared under any of the following conditions.
 - After the secret codes have been registered for two transmitters
 - After one minute elapses since registration mode was set
 - If the MUT-II is disconnected (if the earth connection is broken)
 - If the ignition switch is turned to ON
 - If any of the doors are opened

KEYLESS ENTRY RECEIVER ECU

42800130016

REMOVAL AND INSTALLATION

- Pre-removal and Post-installation Operation**
- Rear Side Trim (R.H.) Removal and Installation (Refer to GROUP 52A.)

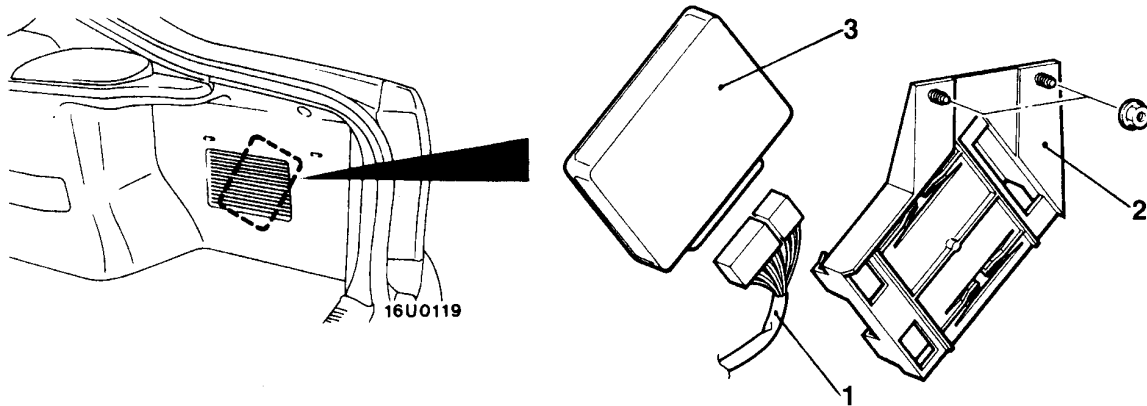

18U0129

00003416

Removal steps

1. Harness connector
2. Keyless entry receiver bracket
3. Keyless entry receiver ECU

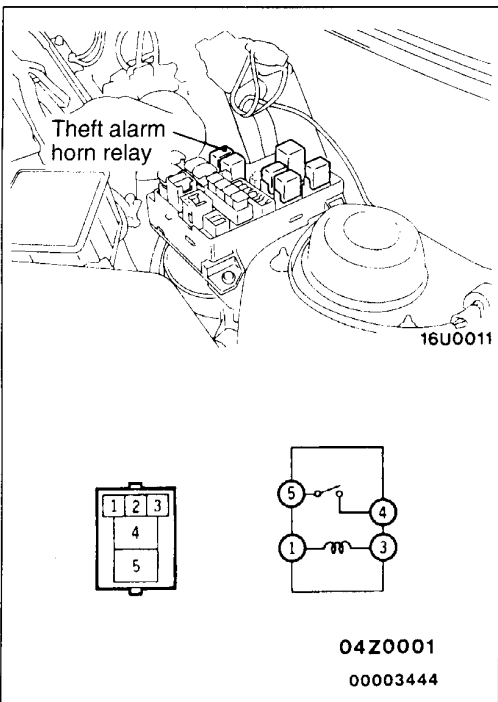

THEFT ALARM HORN

42800230013

INSPECTION





THEFT ALARM HORN RELAY CONTINUITY CHECK

Battery voltage	Terminal No.			
	1	3	4	5
Power is not supplied	○	○		
Power is supplied	⊕	⊖	○	○

SUNROOF

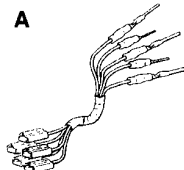
4260060012

SPECIAL TOOLS

Tool	Number	Name	Use
<p>A</p>  <p>B</p>  <p>C</p>  <p>D</p> 	<p>MB991223</p> <p>A: MB991219 B: MB991220 C: MB991221 D: MB991222</p>	<p>Harness set</p> <p>A: Test harness B: LED harness C: LED harness adapter D: probe</p>	<p>Measurement of terminal voltage</p> <p>A: Connector pin contact pressure inspection B, C: Power circuit inspection D: Commercial tester connection</p>

TROUBLESHOOTING

42600200018

INSPECTION CHART FOR TROUBLE SYMPTOMS

Trouble symptom	Inspection procedure	Reference page
Sunroof does not operate at all.	1	42-54
Sunroof does not operate correctly or it does not re-open if it clamps something.	2	42-56
The key off timer does not operate.	3	42-56
If the driver's side door is opened while the key off timer is operating, the sunroof does not operate for a further 30 seconds after the door is opened.	4	42-56

INSPECTION PROCEDURE FOR TROUBLE SYMPTOMS

Inspection Procedure 1

Sunroof does not operate at all.	Probable cause
<p>One of the following items may be defective.</p> <p>Sunroof switch Sunroof motor Sunroof ECU Power supply circuit Earth circuit</p>	<ul style="list-style-type: none"> ● Malfunction of sunroof switch ● Malfunction of front sunroof motor ● Malfunction of front sunroof-ECU ● Malfunction of wiring harness or connector

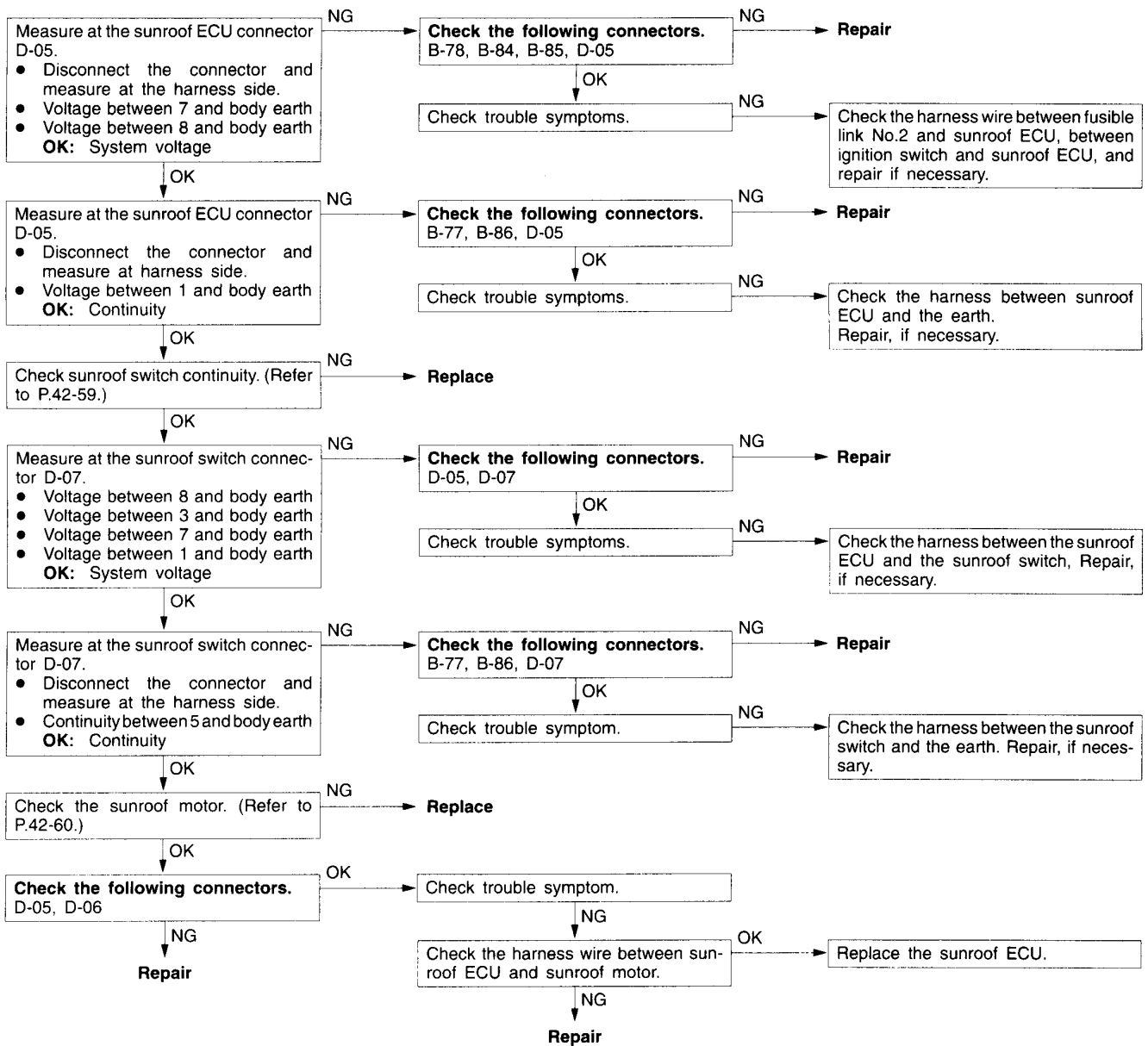

Inspection Procedure 2

Sunroof does not operate correctly or it does not re-open if it clamps something.	Probable cause
The fully-closed position for the sunroof-ECU may have been adjusted incorrectly, or there may be a malfunction of the sunroof-ECU.	<ul style="list-style-type: none"> • Incorrect adjustment of sunroof-ECU fully-closed position • Malfunction of the sunroof ECU • Malfunction of the harness or connector

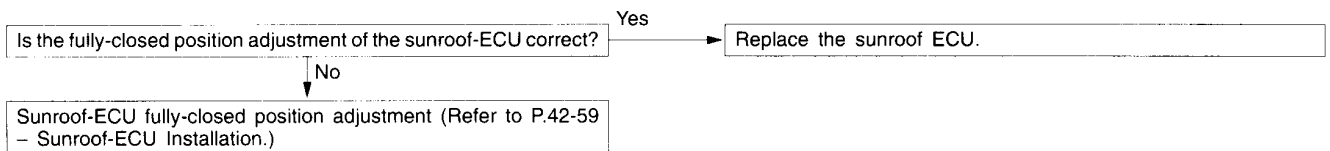

Inspection Procedure 3

The key off timer does not operate.	Probable cause
The sunroof can be operated for a further 30 seconds after the ignition switch is turned to OFF, but if it cannot be operated during this time, there is probably a malfunction of the sunroof-ECU.	<ul style="list-style-type: none"> • Malfunction of the sunroof ECU

Replace the sunroof ECU.

Inspection Procedure 4

If the driver's side door is opened while the key off timer is operating, the sunroof does not operate for a further 30 seconds after the door is opened.	Probable cause
If the driver's door is opened within 30 seconds after the ignition switch is turned to OFF, the sunroof can still be operated for 30 seconds after that point. If it cannot be operated during this time, there is probably a malfunction of the driver's side door switch or of the sunroof-ECU.	<ul style="list-style-type: none"> • Malfunction of the front door switch(driver's side) • Malfunction of the sunroof ECU • Malfunction of harness or connector

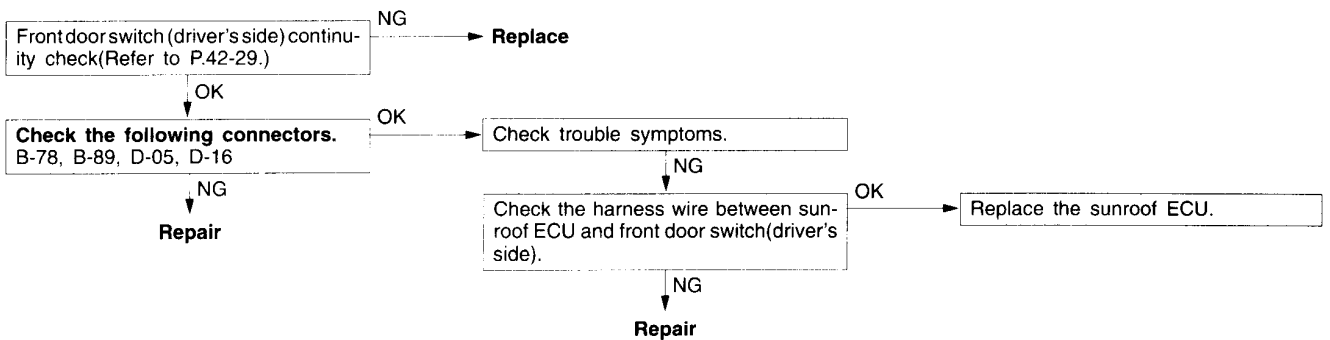

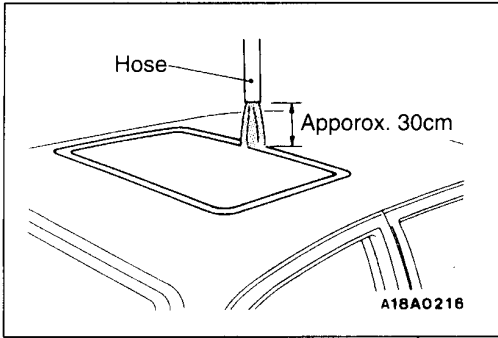

ON-VEHICLE SERVICE

42600090035

WATER TEST

Check if there are any leaks in the sunroof by the following procedure.

- (1) Fully close the roof lid glass.
- (2) Adjust the water pressure so that water comes out of the hose to a height of approximately 50 cm when the hose is held vertically facing upwards.
- (3) Hold the end of the hose about 30 cm above the roof and let the water run onto the weatherstrip for 5 minutes or more.
- (4) While doing this, check if any water leaks through into the passenger compartment from around the roof lid glass.

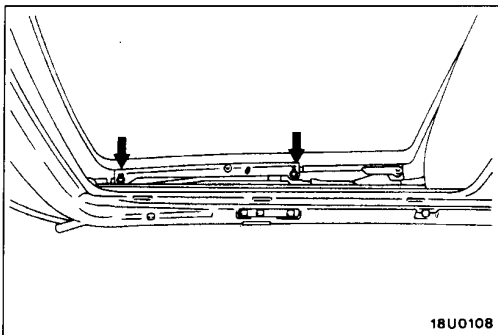

SUNROOF FIT ADJUSTMENT

42600100035

1. Fully close the roof lid glass.
2. Fully open the sunshade.
3. Remove the cover.
4. Loosen the screws and adjust the position of the roof lid glass so that it is flush with the surface of the roof.

SUNROOF

42600120031

REMOVAL AND INSTALLATION

Post-installation Operation
 (1) Sunroof Water Test (Refer to P.42-57.)
 (2) Sunroof Fit Adjustment (Refer to P.42-57.)

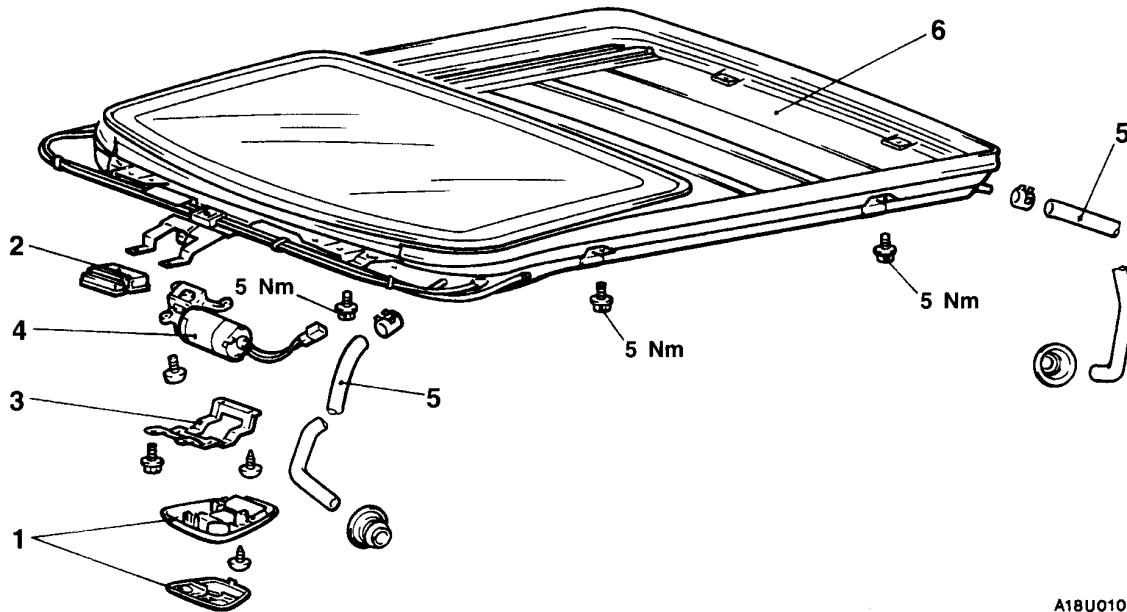

A18U0109

Sunroof ECU removal steps

1. Sunroof switch and room lamp assembly
- Headlining
2. Sunroof ECU



Sunroof motor removal steps

1. Sunroof switch and room lamp assembly
- Headlining
3. Room lamp bracket
4. Sunroof motor

Drain hose removal steps

- Splash shield (Refer to P.42-4.)
- 1. Sunroof switch and room lamp assembly
- Headlining
- 5. Drain hose



Sunroof assembly removal steps

1. Sunroof switch and room lamp assembly
- Headlining
5. Drain hose connection
6. Sunroof assembly

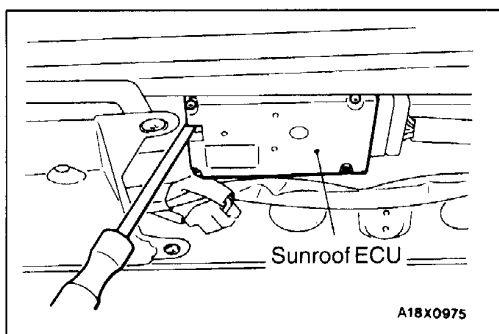

A18X0975

REMOVAL SERVICE POINTS

◀A▶ SUNROOF ECU REMOVAL

1. Close the roof lid glass fully.
2. Insert a flat-tipped screwdriver, place it on the tab, and then press it to the right.
3. Lower sunroof ECU and slide to left.

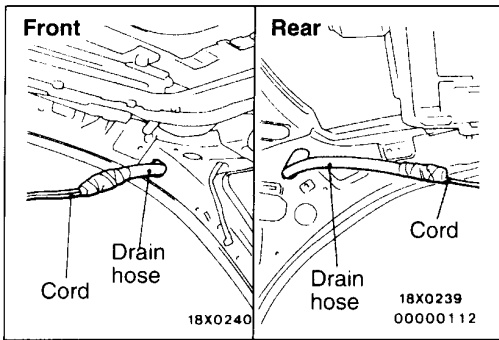

◀B▶ DRAIN HOSE REMOVAL

Remove the grommet. Tie a cord to the end of the drain hose, wind tape around it so that there is no unevenness, and pull the drain hose out into the wheel house.

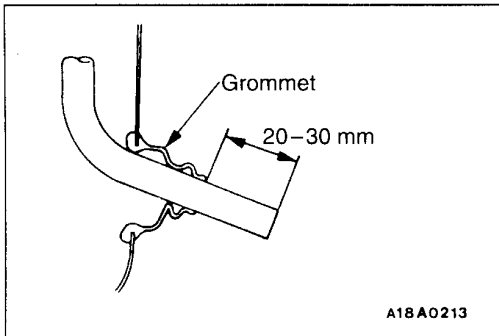

INSTALLATION SERVICE POINTS

▶A◀ DRAIN HOSE INSTALLATION

1. Tie the cord that was used during removal to the end of the drain hose, and wind tape around it so that there is no unevenness.
2. Pull the cord to pull through the drain hose
3. Make the protrusion from the drain hose grommet as shown in the illustration.

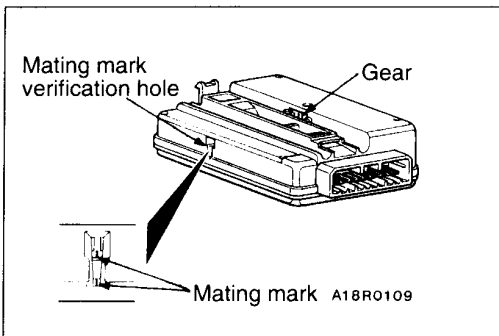

▶B◀ SUNROOF ECU INSTALLATION

1. Fully close the roof lid glass.
2. Turn the gear of the sunroof-ECU until the two mating marks are aligned.

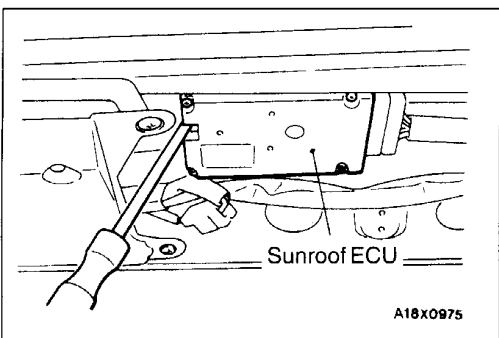

3. Insert a flat-tipped screwdriver, place it on the tab, and press it to the right, being careful not to pinch wiring.

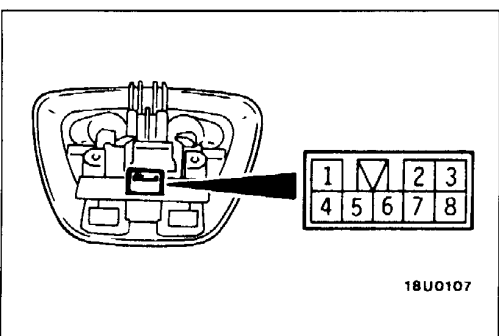

INSPECTION

42600160033

SUNROOF SWITCH CONTINUITY CHECK

Switch position		Terminal No.				
		1	2	3	7	8
Slide switch	OPEN		○			○
	CLOSE		○	○		
Tilt switch	UP		○		○	
	DOWN	○	○			

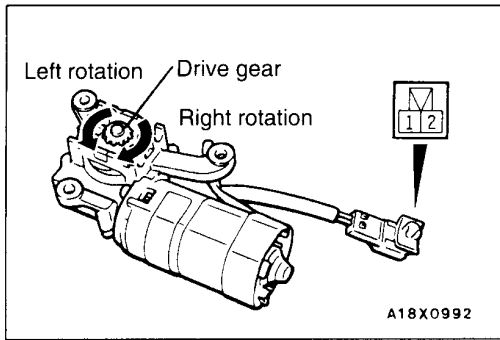

SUNROOF MOTOR CHECK

42600250013

Check the direction of rotation of the drive gear when the battery is connected to the connector.

Battery connection terminal		Drive gear rotation direction
1	2	
⊖	⊕	Right
⊕	⊖	Left

DISASSEMBLY AND REASSEMBLY

42600140037

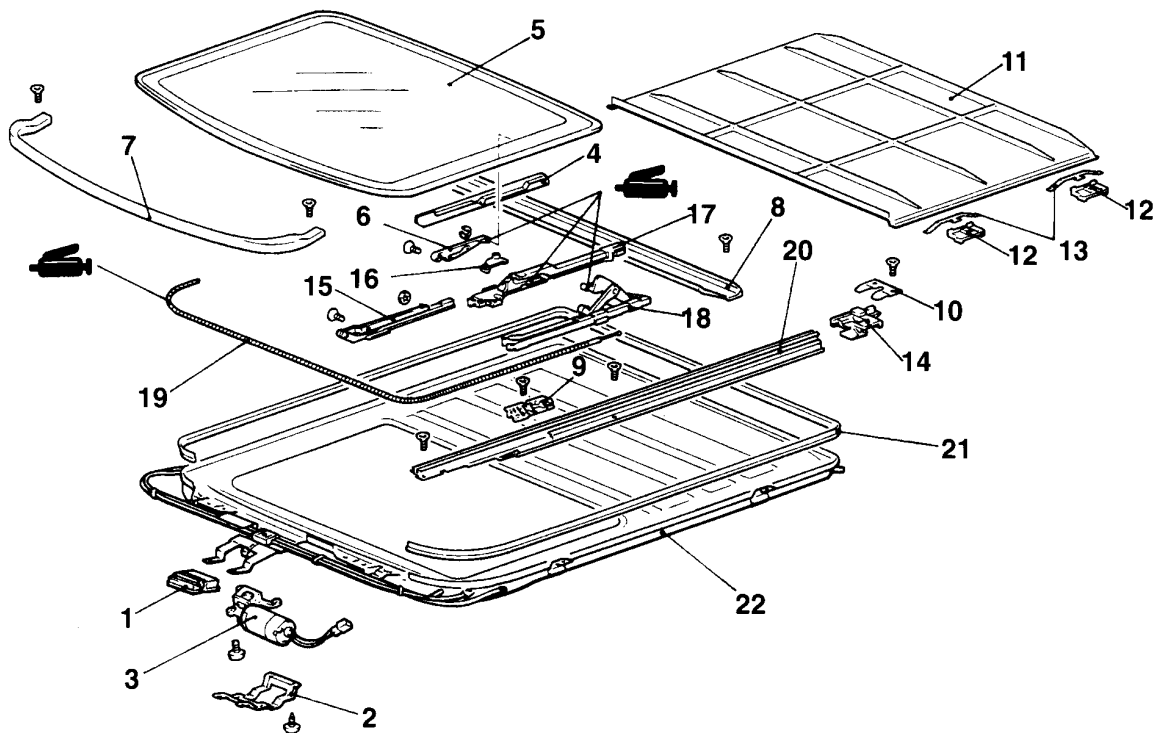

A18U0110

Disassembly steps

- | | |
|---|---|
| <ol style="list-style-type: none"> 1. Sunroof ECU (Refer to P.42-58.) 2. Room lamp bracket 3. Sunroof motor 4. Cover 5. Roof lid glass 6. Curve on panel 7. Winddeflector assembly 8. Drain channel assembly 9. Locator 10. Strong rear stop 11. Sunshade 12. Slide bloke 13. Spring | <ol style="list-style-type: none"> 14. Mechanism stop 15. Basic slide front 16. Blocking catch 17. Basic slid rear 18. Driving slide rear 19. Drive cable 20. Guide 21. Tray seal outer 22. Welded tray assembly |
|---|---|