

CHASSIS ELECTRICAL

CONTENTS

5410900037

BATTERY	4	IGNITION SWITCH AND IMMOBILIZER SYSTEM	15
SERVICE SPECIFICATION	4	COMBINATION METERS	18
ON-VEHICLE SERVICE	4	SERVICE SPECIFICATIONS	18
Fluid Level and Specific Gravity Check	4	SEALANT	18
Charging	5	SPECIAL TOOLS	19
Battery Testing Procedure	6	TROUBLESHOOTING	20
IGNITION SWITCH AND IMMOBILIZER SYSTEM	7		
SPECIAL TOOL	7		
TROUBLESHOOTING	7		

CONTINUED ON NEXT PAGE

WARNINGS REGARDING SERVICING OF SUPPLEMENTAL RESTRAINT SYSTEM (SRS) EQUIPPED VEHICLES

WARNING!

- (1) Improper service or maintenance of any component of the SRS, or any SRS-related component, can lead to personal injury or death to service personnel (from inadvertent firing of the air bag) or to the driver and passenger (from rendering the SRS inoperative).
- (2) Service or maintenance of any SRS component or SRS-related component must be performed only at an authorized MITSUBISHI dealer.
- (3) MITSUBISHI dealer personnel must thoroughly review this manual, and especially its GROUP 52B – Supplemental Restraint System (SRS) before beginning any service or maintenance of any component of the SRS or any SRS-related component.

NOTE

The SRS includes the following components: SRS-ECU, SRS warning lamp, air bag module, clock spring and interconnecting wiring. Other SRS-related components (that may have to be removed/installed in connection with SRS service or maintenance) are indicated in the table of contents by an asterisk (*).

ON-VEHICLE SERVICE	20	FRONT FOG LAMP	38
Speedometer Check	20	SERVICE SPECIFICATIONS	38
Tachometer Check	21	SPECIAL TOOL	38
Fuel Gauge Simple Check	22	ON-VEHICLE SERVICE	38
Fuel Gauge Unit Check	22	Front Fog Lamp Aiming	38
Engine Coolant Temperature Gauge Simple		Bulb Replacement	39
Check	23	FRONT FOG LAMP	40
Engine Coolant Temperature Gauge Unit		REAR COMBINATION LAMP, REAR LID	
Check	24	LAMP*	41
COMBINATION METERS	24	SPECIAL TOOL	41
HEADLAMP AND FRONT		REAR COMBINATION LAMP, REAR LID	
TURN-SIGNAL LAMP*	26	LAMP	41
SERVICE SPECIFICATIONS	26	HIGH MOUNTED STOP LAMP	43
SPECIAL TOOL	26	RHEOSTAT	44
TROUBLESHOOTING	26	SPECIAL TOOL	44
ON-VEHICLE SERVICE	31	RHEOSTAT	44
Headlamp Aiming	31	HAZARD WARNING LAMP	
Intensity Measurement	32	SWITCH	45
Bulb Replacement	33	CIGARETTE LIGHTER	45
HEADLAMP AND FRONT TURN-SIGNAL		CLOCK	46
LAMP	34		
SIDE TURN-SIGNAL LAMP	37		
SPECIAL TOOL	37		

CONTINUED ON NEXT PAGE

RADIO AND TAPE PLAYER	47	DOOR GLASS AND REGULATOR (POWER WINDOWS)	Refer to GROUP 42
TROUBLESHOOTING	47		
Quick-reference Troubleshooting Chart	47		
RADIO AND TAPE PLAYER	62	DOOR HANDLE AND LATCH (DOOR LOCKING)	Refer to GROUP 42
SPEAKER	63		
ANTENNA	64	SUNROOF	Refer to GROUP 42
POLE ANTENNA	64	WINDSHIELD WIPER AND WASHER	Refer to GROUP 51
MOTOR ANTENNA	65	REAR WIPER AND WASHER	Refer to GROUP 51
REAR WINDOW DEFOGGER	67	DOOR MIRROR (ELECTRONIC CONTROLLED DOOR MIRROR)	Refer to GROUP 51
ON-VEHICLE SERVICE	67	SUPPLEMENTAL RESTRAINT SYSTEM (SRS)	Refer to GROUP 52B
Printed-heater Line Check	67	HEATER	Refer to GROUP 55
REAR WINDOW DEFOGGER SWITCH ...	68	AIR CONDITIONER	Refer to GROUP 55
RADIATOR FAN MOTOR	Refer to GROUP 14		
SERVICE BRAKES (ABS)	Refer to GROUP 35B		

BATTERY

54100030028

SERVICE SPECIFICATION

Item	Specification
Specific gravity of the battery fluid	1.220–1.290 [20°C]

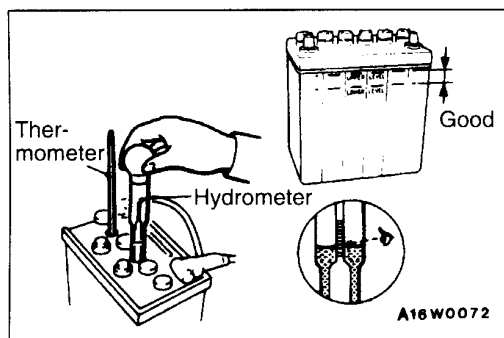

ON-VEHICLE SERVICE

54100090026

FLUID LEVEL AND SPECIFIC GRAVITY CHECK

1. Inspect whether or not the battery fluid is between the UPPER LEVEL and LOWER LEVEL marks.
2. Use a hydrometer and thermometer to check the specific gravity of the battery fluid.

Standard value: 1.220–1.290 [20°C]

The specific gravity of the battery fluid varies with the temperature, so use the following formula to calculate the specific gravity for 20°C. Use the calculated value to determine whether or not the specific gravity is satisfactory.

$$D20 = Dt + 0.0007 (t - 20)$$

D20: Specific gravity of the battery fluid calculated for 20°C.

Dt: Actually measured specific gravity

t: Actually measured temperature

CHARGING

54100110029

1. When charging a battery while still installed in the vehicle, disconnect the battery cables to prevent damage to electrical parts.
2. The current normally used for charging a battery should be approximately 1/10th of the battery capacity.
3. When performing a quick-charging due to lack of time, etc., the charging current should never exceed the battery capacity as indicated in amperes.
4. Determining if charging is completed.
 - (1) If the specific gravity of the battery fluid reaches 1.250–1.290 and remains constant for at least one hour.
 - (2) If the voltage of each cell reaches 2.5–2.8 V and remains constant for at least one hour.

Caution

1. **Be careful since the battery fluid level may rise during charging.**
2. **Keep all sources of fire away while charging because there is a danger of explosion.**
3. **Be careful not to do anything that could generate sparks while charging.**
4. **When charging is completed, replace the battery caps, pour clean water over the battery to remove any sulfuric acid and dry.**

BATTERY TESTING PROCEDURE

TEST STEP

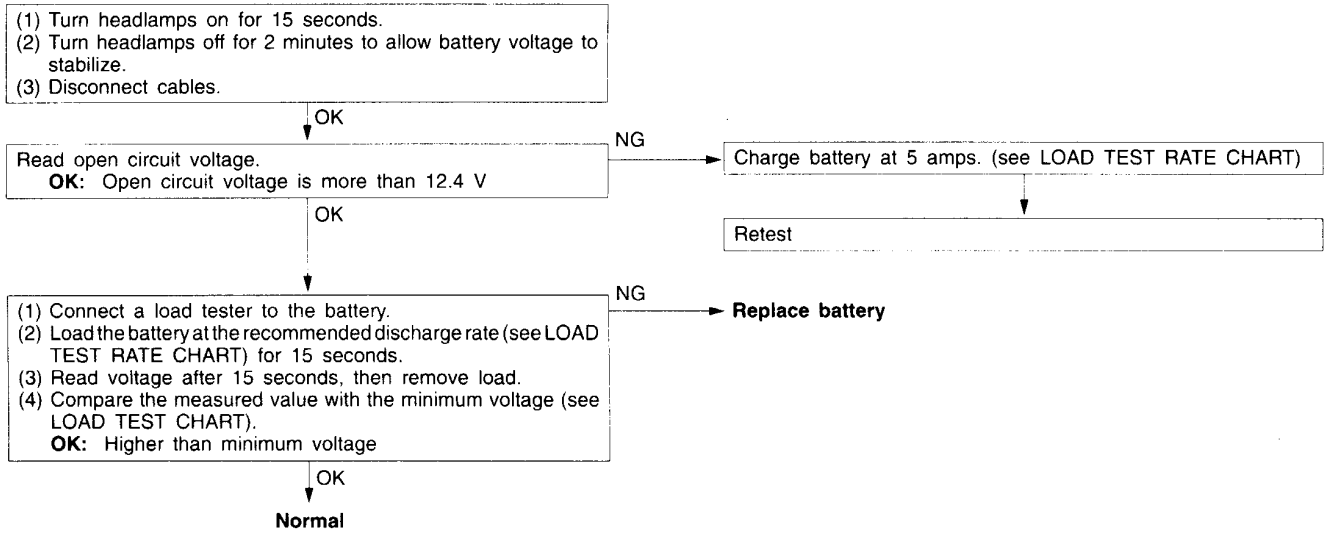

LOAD TEST RATE CHART

Battery type	55530 or 55559	56216 or 56219	56332 or 56638
Charging time when fully discharged h [5-amp rated current charging]	10	11	11
Load test (Amps)	170	210	210

LOAD TEST CHART

Temperature °C	21 and above	16	10	4	-1	-7	-12	-18
Minimum voltage V	9.6	9.5	9.4	9.3	9.1	8.9	8.7	8.5

IGNITION SWITCH AND IMMOBILIZER SYSTEM

5430060092

SPECIAL TOOL

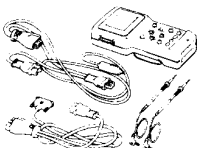
Tool	Number	Name	Use
	MB991502	MUT-II sub assembly	<ul style="list-style-type: none"> • Immobilizer system check (Diagnosis display using the MUT-II) • Registration of the ID code

TROUBLESHOOTING

5430070057

Caution

The ID code should always be re-registered when replacing the immobilizer-ECU.

STANDARD FLOW OF DIAGNOSIS TROUBLESHOOTING

Refer to GROUP 00 – How To Use Troubleshooting/Inspection Service Points.

DIAGNOSIS FUNCTION**DIAGNOSIS CODES CHECK**

Refer to GROUP 00 – How To Use Troubleshooting/Inspection Service Points.

ERASING DIAGNOSIS CODES

Refer to GROUP 00 – How To Use Troubleshooting/Inspection Service Points.

Caution

The diagnosis codes which result from disconnecting the battery cables cannot be erased.

INSPECTION CHART FOR DIAGNOSIS CODES

Diagnosis code No.	Inspection items	Reference page
11	Transponder communication system	54-8
12*	ID code are not the same or are not registered	54-8
21	Communication system between MUT-II and engine-ECU	54-9
31	EEPROM abnormality inside immobilizer-ECU	54-9
32	Ignition switch IG signal circuit system	54-10

NOTE

*: Diagnosis code No. 12 is not recorded.

INSPECTION PROCEDURE FOR DIAGNOSIS CODES

Code No. 11 Transponder communication system	Probable cause
The ID code of the transponder is not sent to the immobilizer-ECU immediately after the ignition switch is turned to the ON position.	<ul style="list-style-type: none"> ● Malfunction of the transponder ● Malfunction of the ignition key ring antenna ● Malfunction of harness or connector ● Malfunction of the immobilizer-ECU

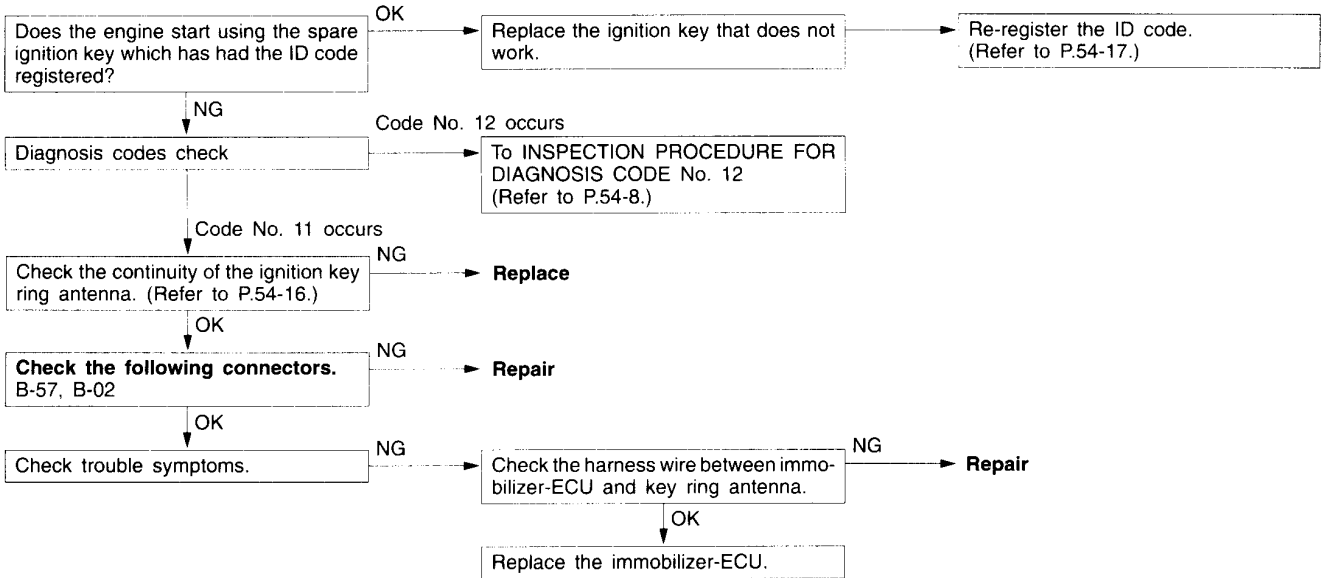

Code No. 12 ID code are not the same or are not registered	Probable cause
The ID code which is sent from the transponder is not the same as the ID code which is registered in the immobilizer-ECU.	<ul style="list-style-type: none"> ● The ID code in the ignition key being used has not been properly registered. ● Malfunction of the immobilizer-ECU

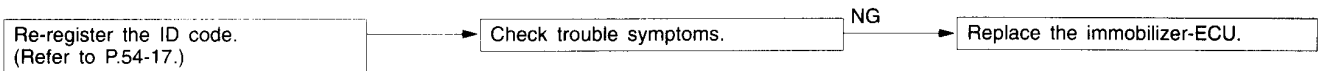

Code No. 21 Communication system between MUT-II and engine-ECU	Probable cause
After the ignition switch is turned to the ON position, the confirmation code is not received from the engine-ECU within the allowable time, or an abnormal code is received.	<ul style="list-style-type: none"> ● Malfunction of harness or connector ● Malfunction of the engine-ECU ● Malfunction of the immobilizer-ECU

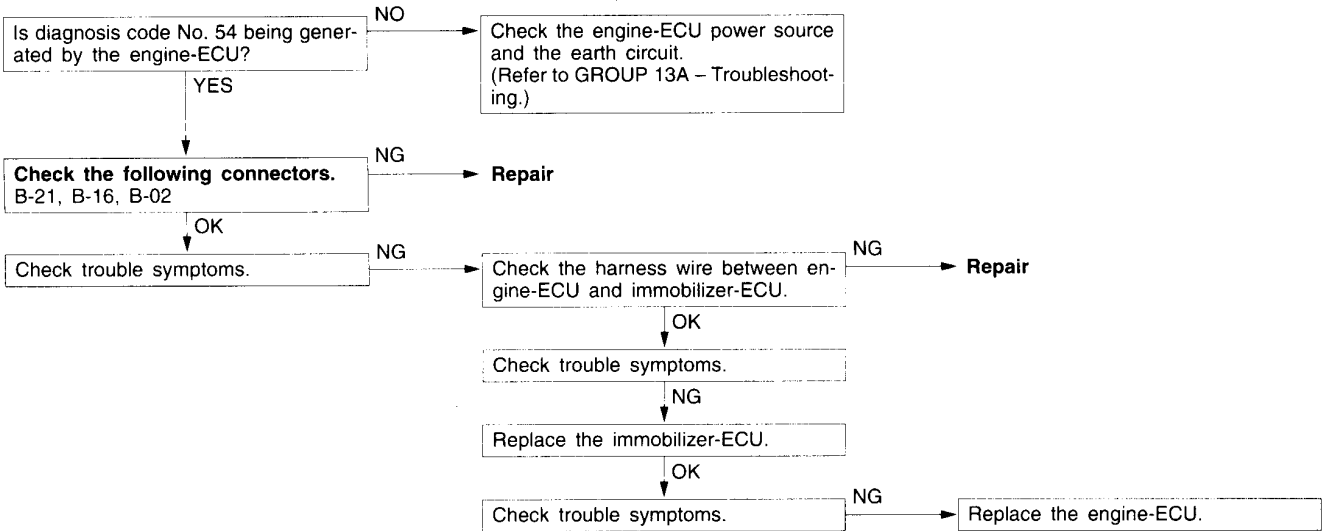

Code No. 31 EEPROM abnormality inside immobilizer-ECU	Probable cause
No data has been written to the EEPROM inside the immobilizer-ECU.	<ul style="list-style-type: none"> ● Malfunction of the immobilizer-ECU

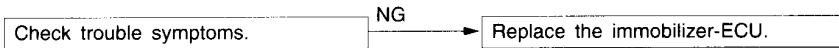

54-10 CHASSIS ELECTRICAL – Ignition Switch and Immobilizer System

Code No. 32 Ignition switch IG signal circuit system	Probable cause
The ignition switch signal is not being input to the immobilizer-ECU.	<ul style="list-style-type: none"> ● Malfunction of harness or connector ● Malfunction of the ignition switch ● Malfunction of the immobilizer-ECU

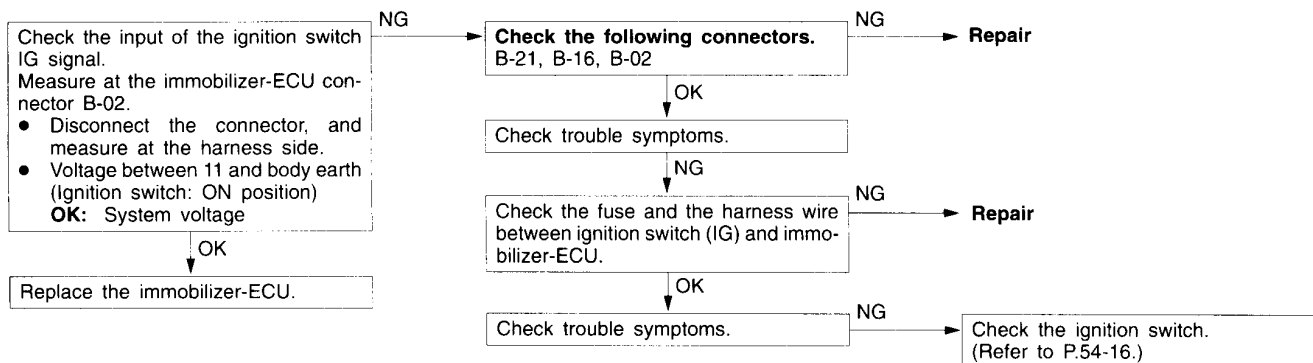

INSPECTION CHART FOR TROUBLE SYMPTOMS

Trouble symptom	Inspection procedure No.	Reference page
Communication with MUT-II is impossible.	1	54-11
Diagnosis code No. 54 has been generated by the engine-ECU.	2	54-12
ID code cannot be registered using the MUT-II.	3	54-12
Engine does not start (Cranking but no initial combustion).	4	54-13
Malfunction of the immobilizer-ECU power source and earth circuit	5	54-14

INSPECTION PROCEDURE FOR TROUBLE SYMPTOMS

Inspection Procedure 1

Communication with MUT-II is impossible.	Probable cause
The cause is probably that a malfunction of the diagnosis line or the immobilizer-ECU is not functioning.	<ul style="list-style-type: none"> ● Malfunction of the diagnosis line ● Malfunction of harness or connector ● Malfunction of the immobilizer

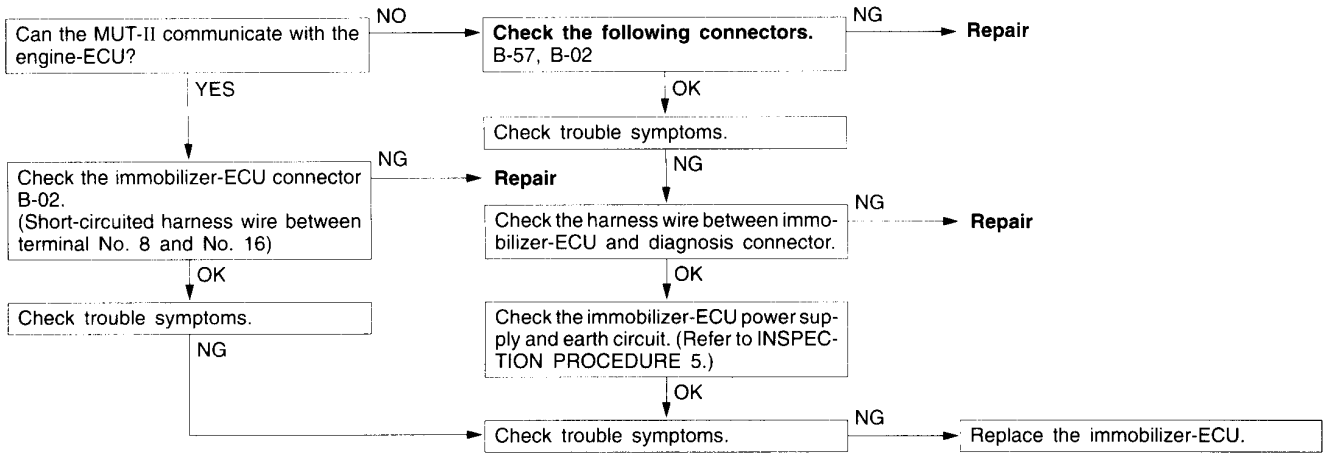

54-12 CHASSIS ELECTRICAL – Ignition Switch and Immobilizer System

Inspection Procedure 2

Diagnosis code No. 54 has been generated by the engine-ECU.	Probable cause
There is a problem with communication between the engine-ECU and the immobilizer-ECU.	<ul style="list-style-type: none"> ● Malfunction of harness or connector ● Malfunction of the immobilizer-ECU ● Malfunction of the engine-ECU

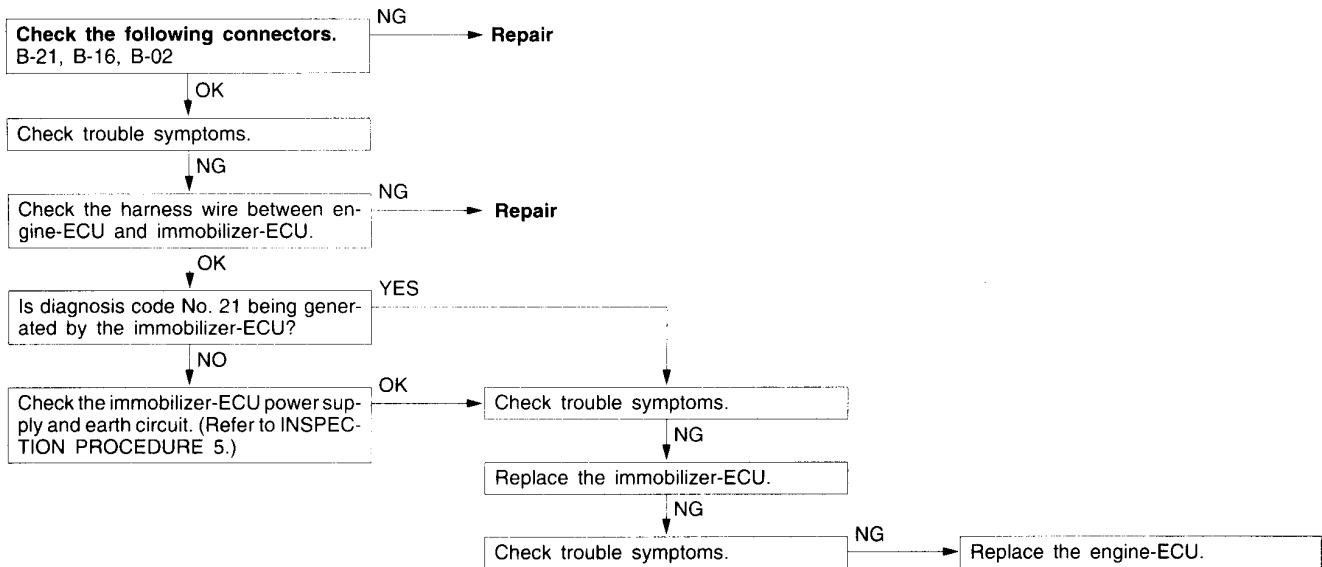

Inspection Procedure 3

ID code cannot be registered using the MUT-II.	Probable cause
The cause is probably that there is no ID code registered in the immobilizer-ECU, or there is a malfunction of the immobilizer-ECU.	<ul style="list-style-type: none"> ● Malfunction of the transponder ● Malfunction of the ignition key ring antenna ● Malfunction of harness or connector ● Malfunction of the immobilizer-ECU

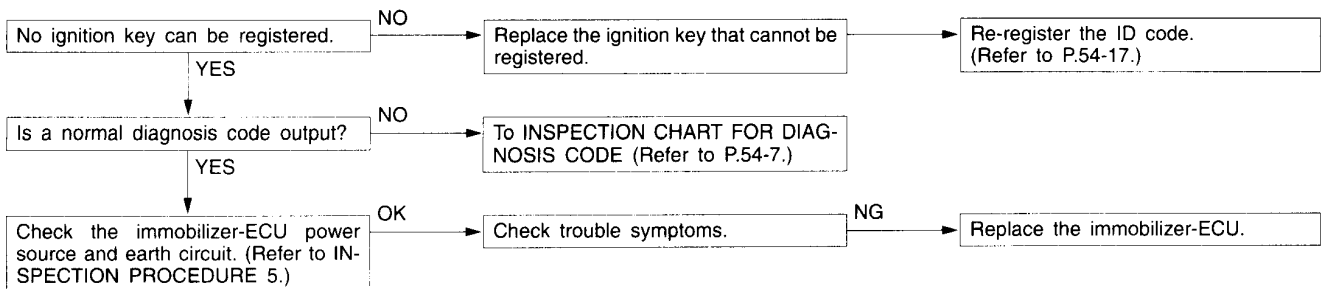

Inspection Procedure 4

Engine does not start (cranking but no initial combustion).	Probable cause
If the fuel injectors are not operating, there might be a problem with the MPI system in addition to a malfunction of the immobilizer system. It is normal for this to occur if an attempt is made to start the engine using a key that has not been properly registered.	<ul style="list-style-type: none"> ● Malfunction of the MPI system ● Malfunction of the immobilizer-ECU

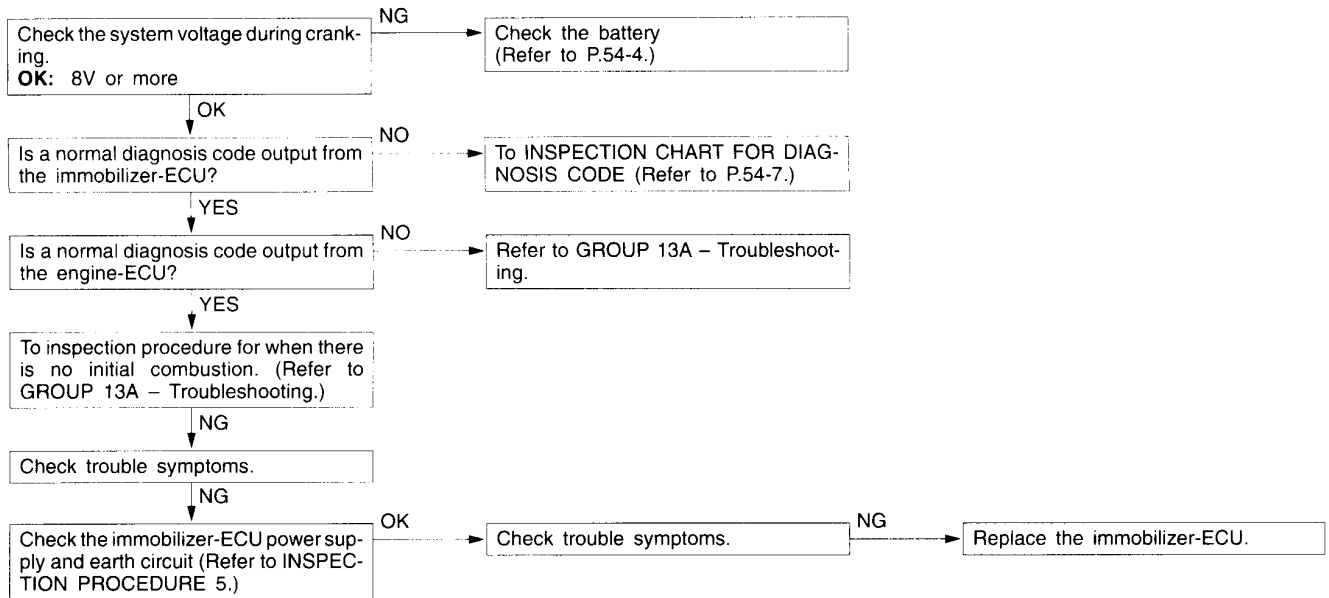

54-14 CHASSIS ELECTRICAL – Ignition Switch and Immobilizer System

Inspection Procedure 5

Malfunction of the immobilizer-ECU power supply and earth circuit

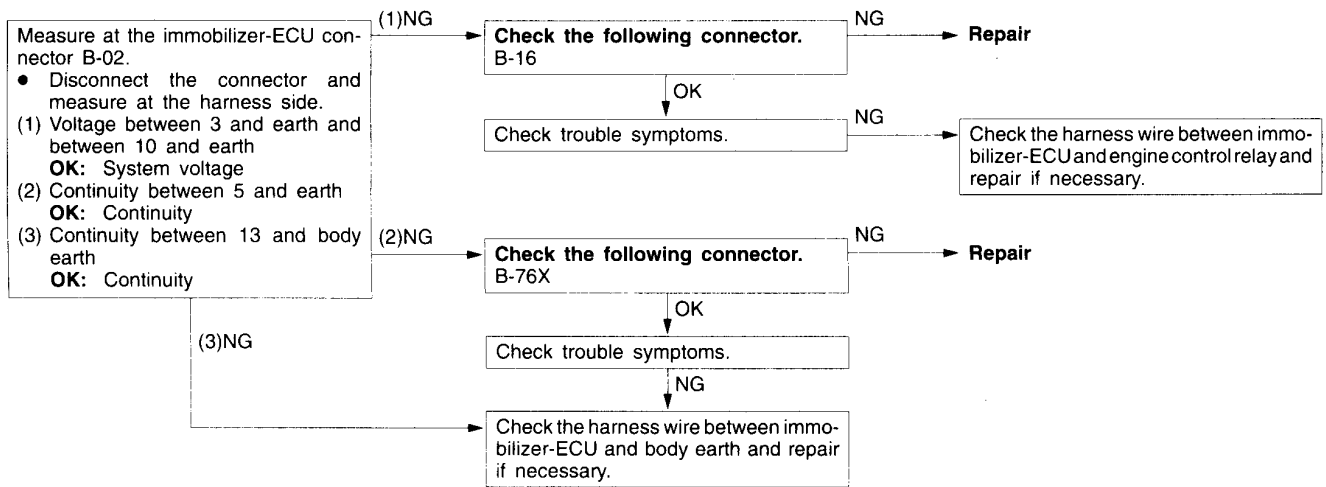

CHECK AT IMMOBILIZER-ECU TERMINAL VOLTAGE CHECK CHART

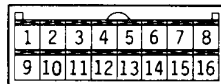

16W0390

Terminal No.	Signal	Checking requirements	Terminal voltage
3	Immobilizer-ECU power supply	Ignition switch: ON	System voltage
5	Immobilizer-ECU earth	Always	0V
10	Immobilizer-ECU power supply	Ignition switch: ON	System voltage
11	Ignition switch-IG	Ignition switch: OFF	0V
		Ignition switch: ON	System voltage
13	Immobilizer-ECU earth	Always	0V

IGNITION SWITCH AND IMMOBILIZER SYSTEM

54300210039

REMOVAL AND INSTALLATION

Caution: SRS
 Before removal of air bag module and clock spring, refer to GROUP 52B – Service Precautions and Air Bag Module and Clock Spring.

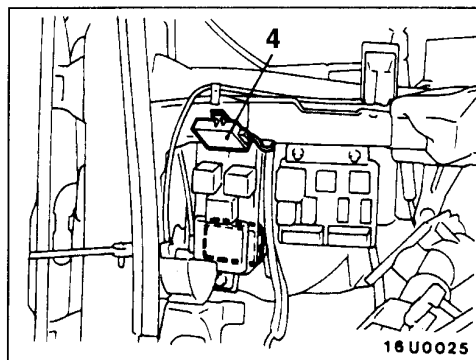
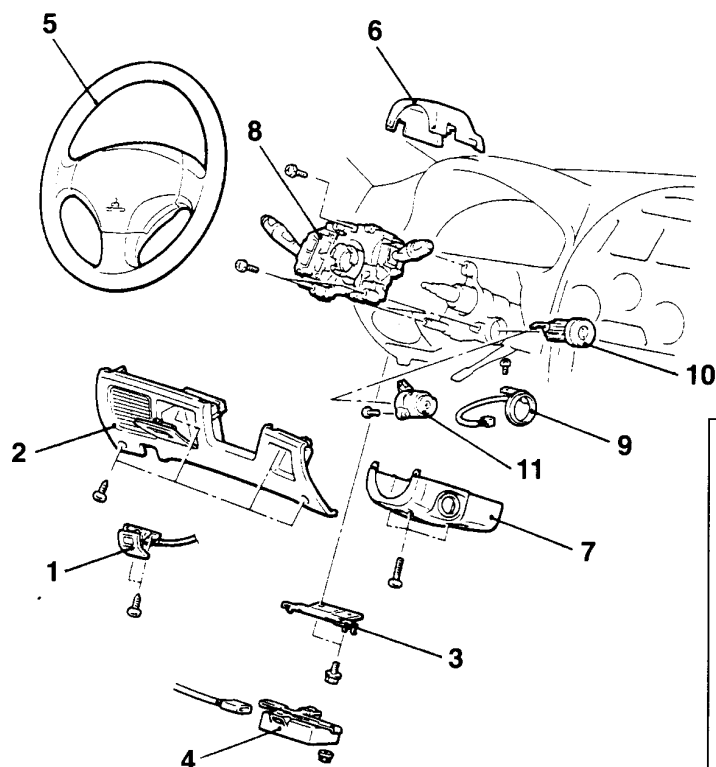

16U0116

00003454

Immobilizer-ECU removal steps

1. Hood lock release handle
2. Instrument under cover (Refer to GROUP 52A – Instrument Panel.)
3. Bracket
4. Immobilizer-ECU

Ignition switch and ignition key ring antenna removal steps

1. Hood lock release handle
2. Instrument under cover (Refer to GROUP 52A – Instrument Panel.)
5. Steering wheel (Refer to GROUP 37A.)
6. Column cover, upper
7. Column cover, lower
8. Column switch (Refer to GROUP 37A – Steering Wheel and Shaft.)
9. Ignition key ring antenna
10. Steering lock cylinder
11. Ignition switch



54-16 CHASSIS ELECTRICAL – Ignition Switch and Immobilizer System

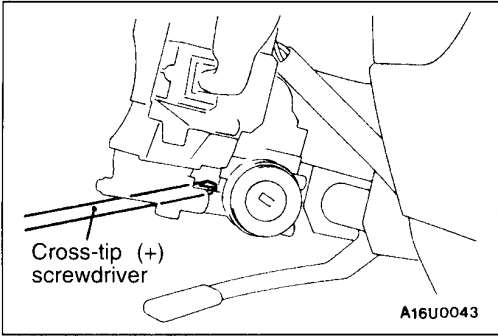

REMOVAL SERVICE POINTS

◀▶ STEERING LOCK CYLINDER REMOVAL

1. Insert the key in the steering lock cylinder and turn it to the "ACC" position.
2. Using a cross-tip (+) screwdriver (small) or a similar tool, push the lock pin of the steering lock cylinder inward and then pull the steering lock cylinder toward you.

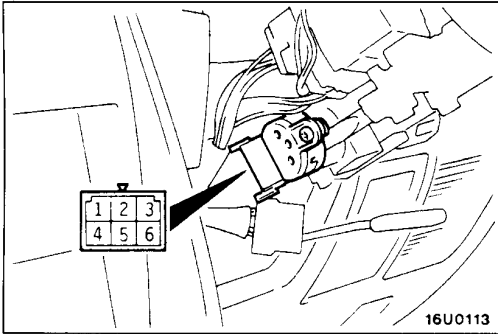

INSPECTION

54300220032

IGNITION SWITCH CONTINUITY CHECK

1. Remove the column cover lower and upper.
2. Disconnect the wiring connector from the ignition switch.
3. Operate the switch, and check the continuity between the terminals.

Ignition key position	Terminal No.					
	1	2	3	4	5	6
LOCK						
ACC	○					○
ON	○	○		○		○
START	○	○	○		○	

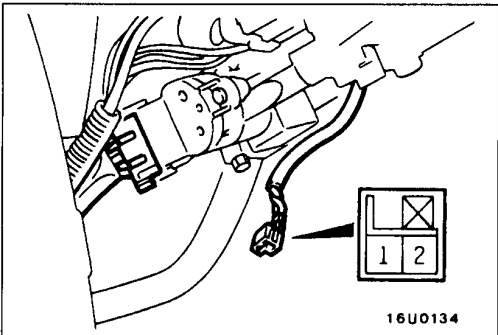

IGNITION KEY RING ANTENNA CONTINUITY CHECK

Use a circuit tester to check the continuity between the terminals.

ID CODE REGISTRATION METHOD

54300810017

If using an ignition key that has just been newly purchased, or if the immobilizer-ECU has been replaced, you will need to register the ID codes for each ignition key being used into the immobilizer-ECU. (A maximum of eight different ID codes can be registered.)

Moreover, when the immobilizer-ECU has been replaced, you will need to use the MUT-II to register the ID number that the user specifies into the immobilizer-ECU. (Refer to the MUT-II instruction manual for instructions on using the MUT-II.)

Caution

If registering of the ID codes is carried out all previously-registered codes will be erased. Accordingly, you should have ready all of the ignition keys that have already been registered.

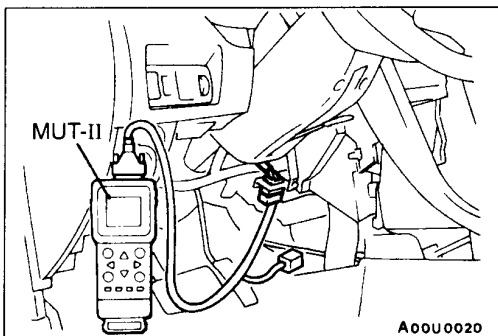

- (1) Connect the MUT-II to the diagnosis connector.

Caution

Connection and disconnection of the MUT-II should always be carried out with the ignition switch in the OFF position.

- (2) Use the ignition key that is to be registered to turn the ignition switch to the ON position.
- (3) Use the MUT-II to register the ID code. If you are registering two or more codes, use the next key to be registered to turn the ignition switch to the ON position without disconnecting the MUT-II.
- (4) Disconnect the MUT-II. This completes the registration operation.

COMBINATION METERS

54300030031

SERVICE SPECIFICATIONS

Items		Standard value	
Speedometer indication error km/h(mph)	40 (20)	40–48 (20–25)	
	80 (40)	80–92 (40–47)	
	120 (60)	120–136 (60–69)	
	160 (80)	160–180 (80–91)	
	– (100)	– (100–114)	
Tachometer indication error r/min	Vehicles with SOHC engine	700	±100
		3,000	±150
		5,000	±250
		6,000	±300
	Vehicles with DOHC engine	700	±100
		3,000	+225, –100
		5,000	+325, –125
		7,000	+400, –100
Fuel gauge unit resistance Ω	Float point F	7.9–14.6	
	Float point E	107.9–118.9	
Fuel gauge unit float height mm	A (Float point F)	142.4	
	B (Float point E)	28	
Fuel gauge resistance Ω	Power supply and earth	122–153	
	Power supply and fuel gauge	27–35	
	Fuel gauge and earth	95–119	
Engine coolant temperature gauge resistance Ω	Power supply and earth	185–227	
	Power supply and engine coolant temperature gauge	54–58	
	Engine coolant temperature gauge and earth	239–285	
Engine coolant temperature gauge unit resistance (at 70°C) Ω		104±13.5	





SEALANT

54300050037

Items	Specified sealant	Remark
Engine coolant temperature gauge unit threaded portion	3M Adhesive nut locking No. 4171 or equivalent	Drying sealant

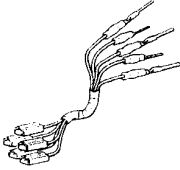
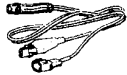
SPECIAL TOOLS

54300060108

Tool	Number	Name	Use
<p>A</p>  <p>B</p>  <p>C</p>  <p>D</p> 	<p>MB991223</p> <p>A: MB991219</p> <p>B: MB991220</p> <p>C: MB991221</p> <p>D: MB991222</p>	<p>Harness set</p> <p>A: Test harness</p> <p>B: LED harness</p> <p>C: LED harness adapter</p> <p>D: Probe</p>	<ul style="list-style-type: none"> ● Fuel gauge simple check A: Connector pin contact pressure check B, C: Power circuit check D: Commercial tester connection
	<p>MB990784</p>	<p>Ornament remover</p>	<p>Removal of meter hood</p>

TROUBLESHOOTING

54300070064

INSPECTION CHART FOR TROUBLE SYMPTOMS

Trouble symptom	Inspection procedure	Reference page
Tachometer does not operate.	1	54-20

INSPECTION PROCEDURE FOR TROUBLE SYMPTOMS

Inspection Procedure 1

Tachometer does not operate.	Probable cause
The ignition signal may not be input from the engine, or there may be a malfunction in the power supply or earth circuit.	<ul style="list-style-type: none"> Malfunction of tachometer Malfunction of harness or connector

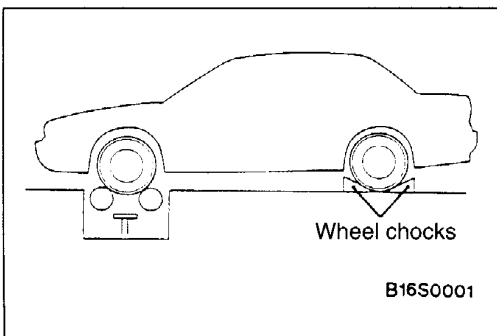
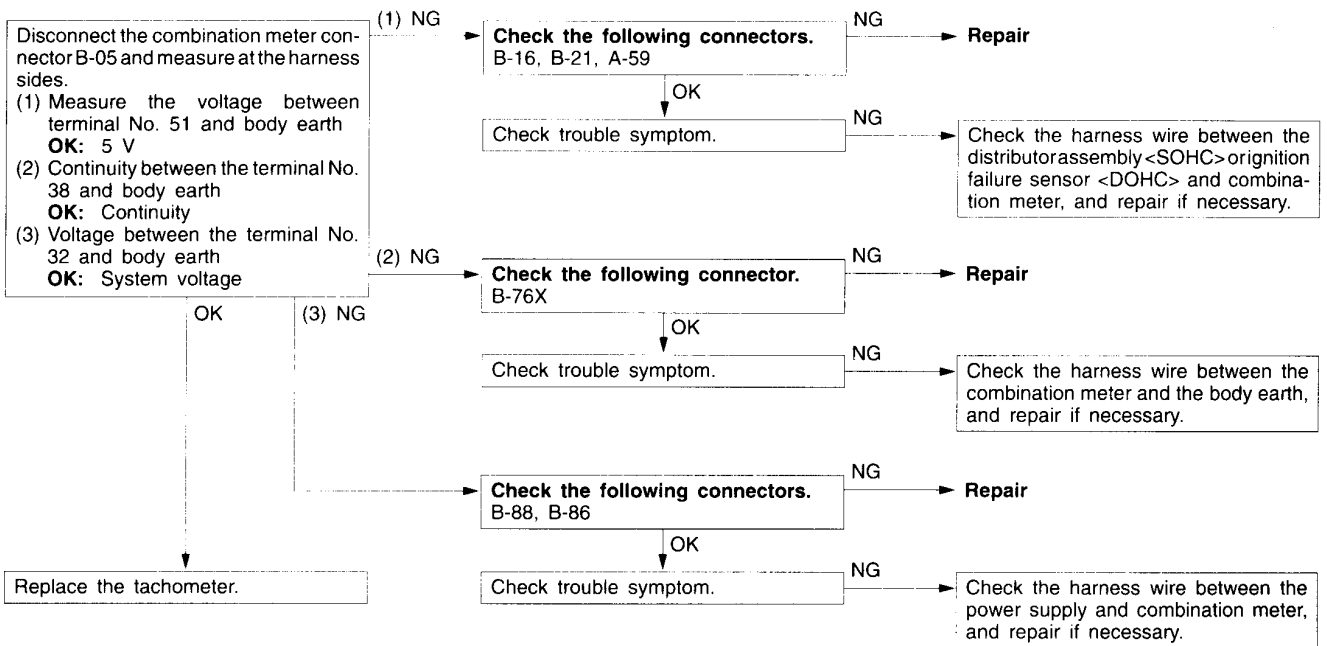

ON-VEHICLE SERVICE

54300090039

SPEEDOMETER CHECK

1. Adjust the pressure of the tyres to the specified level. (Refer to GROUP 31 – Service Specifications.)
2. Set the vehicle onto a speedometer tester and use wheel chocks to hold the rear wheels.

3. Check if the speedometer indicator range is within the standard values.

Caution

Do not operate the clutch suddenly. Do not increase/decrease speed rapidly while testing.

Standard values:

Standard indication km/h (mph)	Allowable range km/h (mph)
40 (20)	40–48 (20–25)
80 (40)	80–92 (40–47)
120 (60)	120–136 (60–69)
160 (80)	160–180 (80–91)
– (100)	– (100–114)

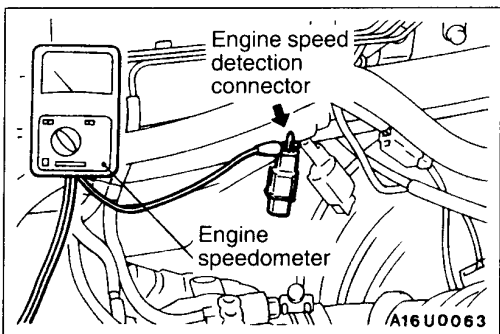
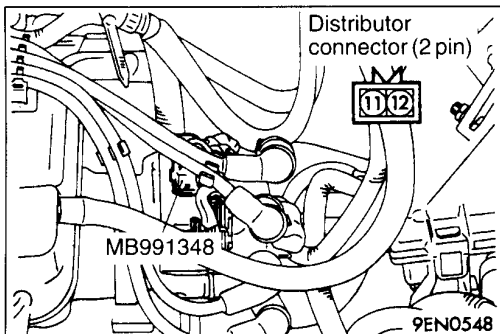

TACHOMETER CHECK

54300100039

<SOHC>

1. Disconnect the distributor connector (2-pin), and connect the special tool in between. All terminals should be connected.
2. Connect a primary voltage-detection type of tachometer to terminal (12) of the distributor connector.
3. Compare the readings of the engine speedometer and the tachometer at every engine speed, and check if the variations are within the standard values.

Standard values:

- 700 r/min: ±100 r/min
- 3,000 r/min: ±150 r/min
- 5,000 r/min: ±250 r/min
- 6,000 r/min: ±300 r/min

<DOHC>

1. Insert a paper clip in the engine speed detection connector from the harness side, and attach the engine speedometer.

NOTE

For tachometer check, use of a fluxmeter-type engine speedometer is recommended. (Because a fluxmeter only needs to be clipped to the high tension cable.)

2. Compare the readings of the engine speedometer and the tachometer at every engine speed, and check if the variations are within the standard values.

Standard values:

- 700 r/min. : ±100 r/min.
- 3,000 r/min : +225 r/min, –100 r/min
- 5,000 r/min : +325 r/min, –125 r/min
- 7,000 r/min : +400 r/min, –100 r/min

FUEL GAUGE SIMPLE CHECK

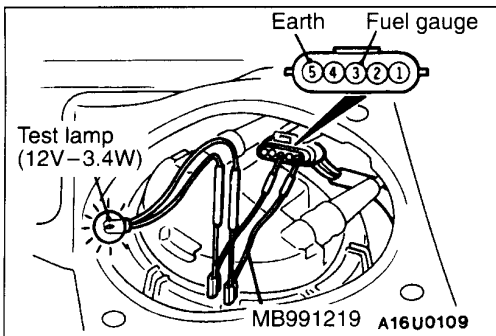
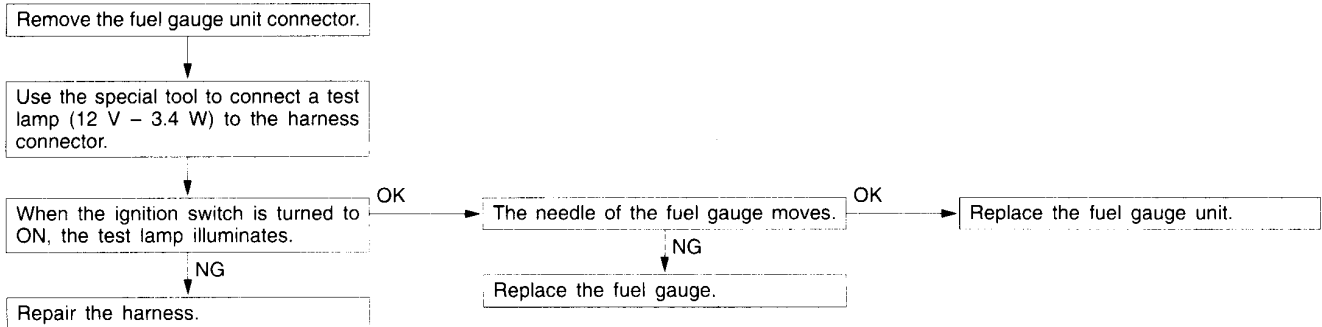

FUEL GAUGE UNIT CHECK

Remove the fuel gauge unit from the fuel tank.
(Refer to GROUP 13F.)

FUEL GAUGE UNIT RESISTANCE

1. Check that resistance value between the fuel gauge terminal and earth terminal is at standard value when fuel gauge unit float is at point F (highest) and point E (lowest).

Standard value:

Point F: 7.9–14.6 Ω

Point E: 107.9–118.9 Ω

2. Check that resistance value changes smoothly when float moves slowly between point F (highest) and point E (lowest).

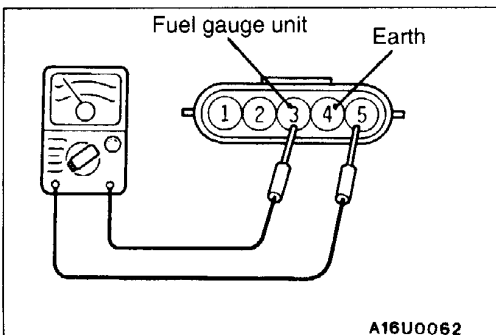

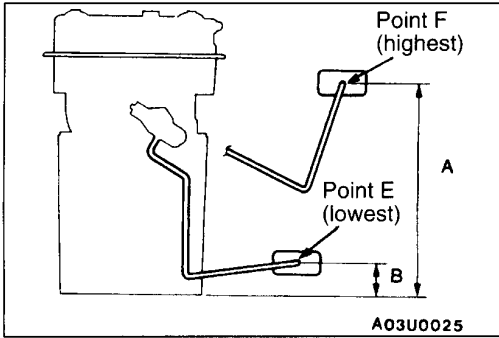

FUEL GAUGE UNIT FLOAT HEIGHT

Move float and measure the height A at point F (highest) and B at point E (lowest) with float arm touching stopper.

Standard value:
A: 142.4 mm
B: 28 mm

ENGINE COOLANT TEMPERATURE GAUGE SIMPLE CHECK

54300140048

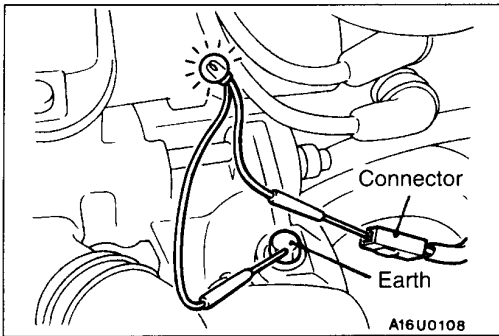
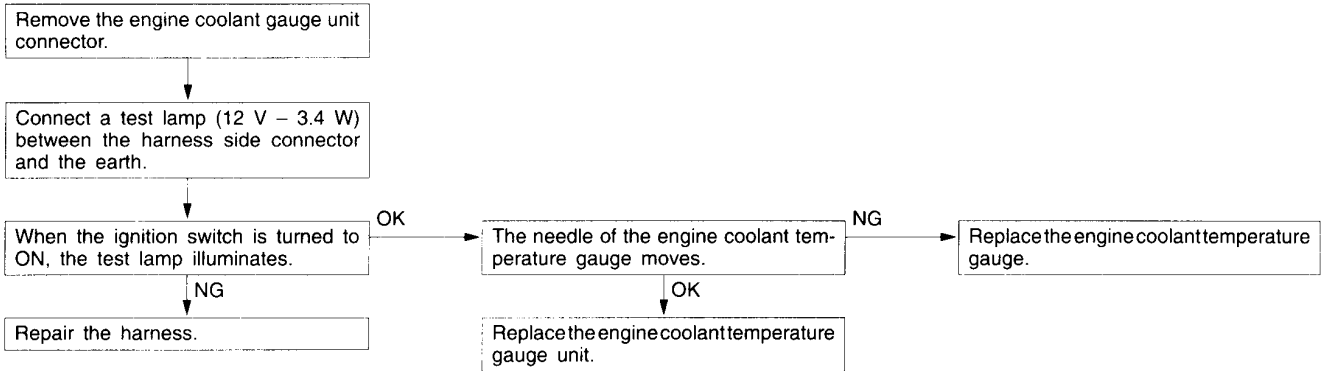

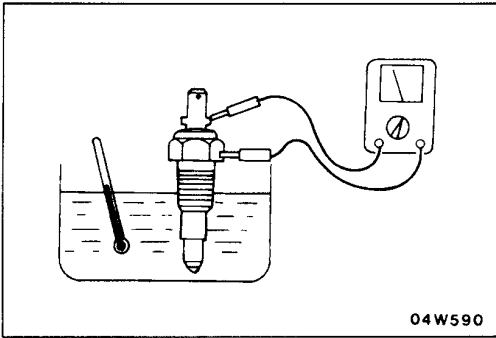

ENGINE COOLANT TEMPERATURE GAUGE UNIT CHECK

54300150041

1. Bleed the engine coolant. (Refer to GROUP 14 – On-vehicle Service.)
2. Remove the engine coolant temperature gauge unit.
3. Immerse the unit in 70°C water to measure the resistance.

Standard value: 104±13.5 Ω

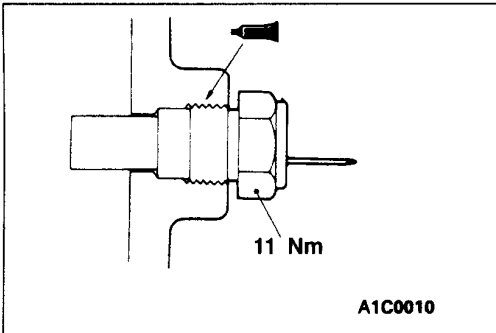

4. After checking, apply the specified adhesive around the thread of engine coolant temperature gauge unit.

Specified sealant:

3M Adhesive Nut Locking No. 4171 or equivalent

5. Add engine coolant. (Refer to GROUP 14 – On-vehicle Service.)

COMBINATION METERS REMOVAL AND INSTALLATION

54300290033

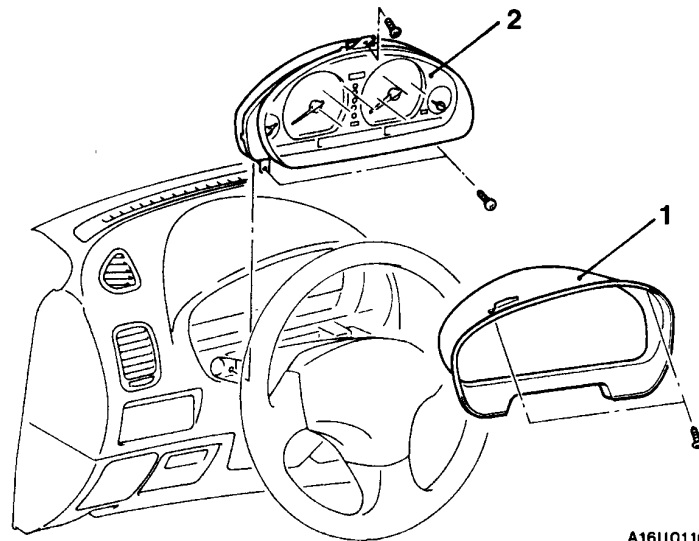

Removal steps

1. Meter hood
2. Combination meter

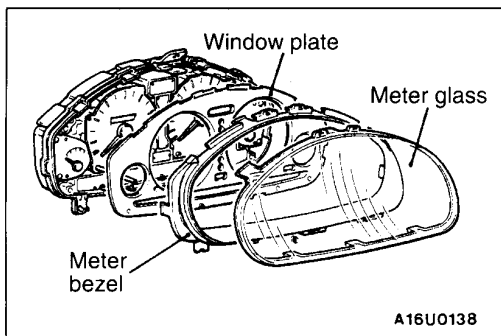

INSPECTION

54300300019

FUEL GAUGE RESISTANCE CHECK

(1) Remove the meter glass, meter bezel and window plate.

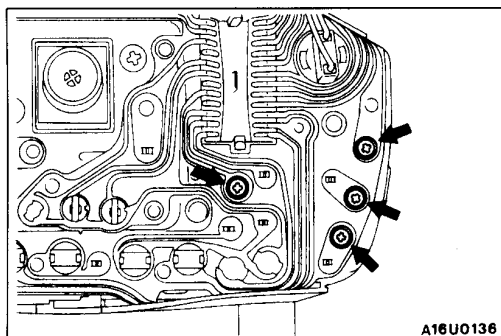

(2) Remove the fuel gauge mounting screws, and then remove the fuel gauge from the meter case.

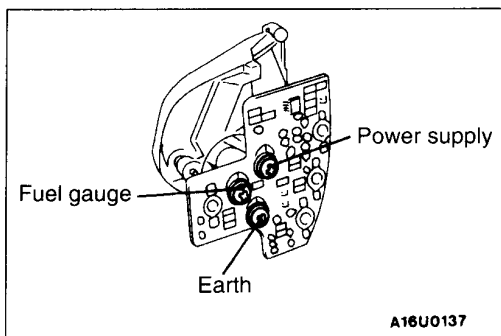

(3) Use a circuit tester to measure the resistance value between the terminals.

Standard value:

- Power supply – Earth: 122–153 Ω
- Power supply – Fuel gauge: 27–35 Ω
- Fuel gauge – Earth: 95–119 Ω

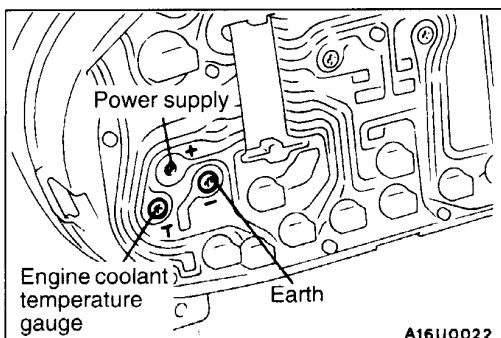

ENGINE COOLANT TEMPERATURE GAUGE RESISTANCE CHECK

1. Remove the power supply tightening screw.
2. Use a circuit tester to measure the resistance value between the terminals.

NOTE

The terminal positions are indicated by T, (-) and (+).

Standard value:

- Power supply (+)–Earth (-): 185–227 Ω
- Power supply (+)–Engine coolant temperature gauge (T): 54–58 Ω
- Engine coolant temperature gauge(T) –Earth (-): 239–285 Ω

Caution

When inserting the testing probe into the power supply terminal, be careful not to touch the printed board.

HEADLAMP AND FRONT TURN-SIGNAL LAMP



54200030052

SERVICE SPECIFICATIONS

Items		Standard value	Limit
Headlamp aiming for low beam	Vertical direction	60 mm below horizontal (H)	–
	Horizontal direction	Position where the 15° sloping section intersects the vertical line (V)	–
Headlamp intensity cd		–	30,000 or more

SPECIAL TOOLS

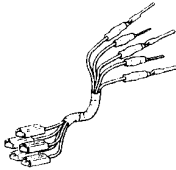
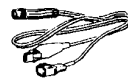
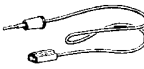
54200060099

Tool	Number	Name	Use
<p>A</p> 	<p>MB991223</p> <p>A: MB991219</p> <p>B: MB991220</p> <p>C: MB991221</p> <p>D: MB991222</p>	<p>Harness set</p> <p>A: Test harness</p> <p>B: LED harness</p> <p>C: LED harness adapter</p> <p>D: Probe</p>	<ul style="list-style-type: none"> Making voltage and resistance measurements during troubleshooting <p>A: Connector pin contact pressure inspection</p> <p>B, C: Power circuit inspection</p> <p>D: Commercial tester connection</p>
<p>B</p> 			
<p>C</p> 			
<p>D</p> 			
	MB990784	Ornament remover	Removal of switch garnish

TROUBLESHOOTING

54200070054

The special tool (MB991223) should always be used to measure voltages and resistances when carrying out troubleshooting.

INSPECTION CHART FOR TROUBLE SYMPTOMS

Trouble symptoms	Inspection procedure	Reference page
<p>The lighting monitor buzzer doesn't sound under the following conditions while tail lamps or headlamps illuminate.</p> <ul style="list-style-type: none"> When the ignition switch is turned to OFF and the driver's side door is open. 	1	54-27
Headlamp leveling does not occur when the headlamp leveling switch is operated.	3	54-28

Trouble symptoms	Inspection procedure	Reference page
The headlamps do not illuminate when the vehicle is in the following condition and the ignition switch is at the ON position. However, the headlamps illuminate when the lighting switch is moved to the HEAD position. <Vehicles with daytime running lamp system> <ul style="list-style-type: none"> Lighting switch: OFF Passing switch: OFF 	4	54-29
The headlamps do not switch off when the vehicle is in the following condition and the lighting switch is moved to the TAIL position. <Vehicles with daytime running lamp system> <ul style="list-style-type: none"> Ignition switch: OFF Passing switch: OFF 	5	54-30

INSPECTION PROCEDURE FOR TROUBLE SYMPTOMS

Inspection Procedure 1

<p>The ignition switch is turned to the OFF position and the driver's side door is opened while the tail lamps or headlamps are operating, but the light reminder warning buzzer does not sound.</p>	<p>Probable cause</p> <ul style="list-style-type: none"> Malfunction of driver's side door switch Malfunction of harness or connector Malfunction of BUZZER-ECU
<p>The cause is probably a defective lighting switch input circuit system or a defective driver's side door switch input circuit system.</p>	

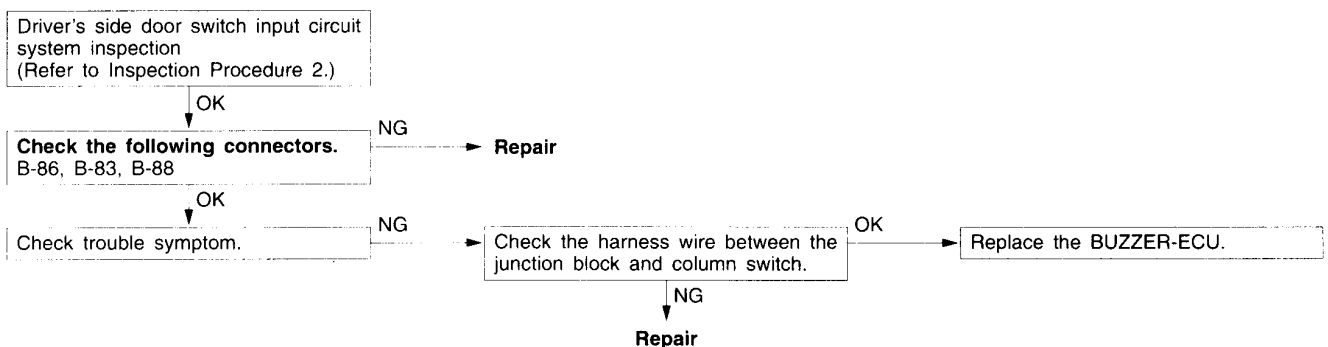

Inspection Procedure 2

Driver's side door switch input circuit system inspection

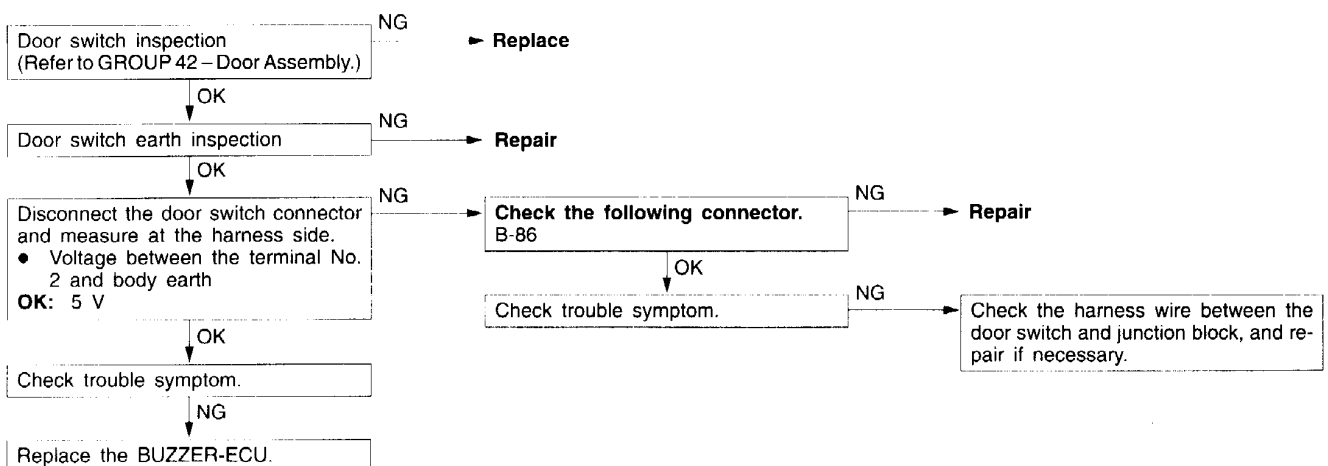

54-28 CHASSIS ELECTRICAL – Headlamp and Front Turn-signal Lamp

Inspection procedure 3

Headlamp leveling does not occur when the headlamp leveling switch is operated. Probable cause

The cause is probably a malfunction of the headlamp leveling switch circuit system or a malfunction of the headlamp leveling unit circuit system.
If there is a blown fuse, there may also be a short-circuit in a harness.

- Malfunction of fuse
- Malfunction the headlamp leveling switch
- Malfunction of connector
- Malfunction of harness
- Malfunction of the headlamp leveling unit

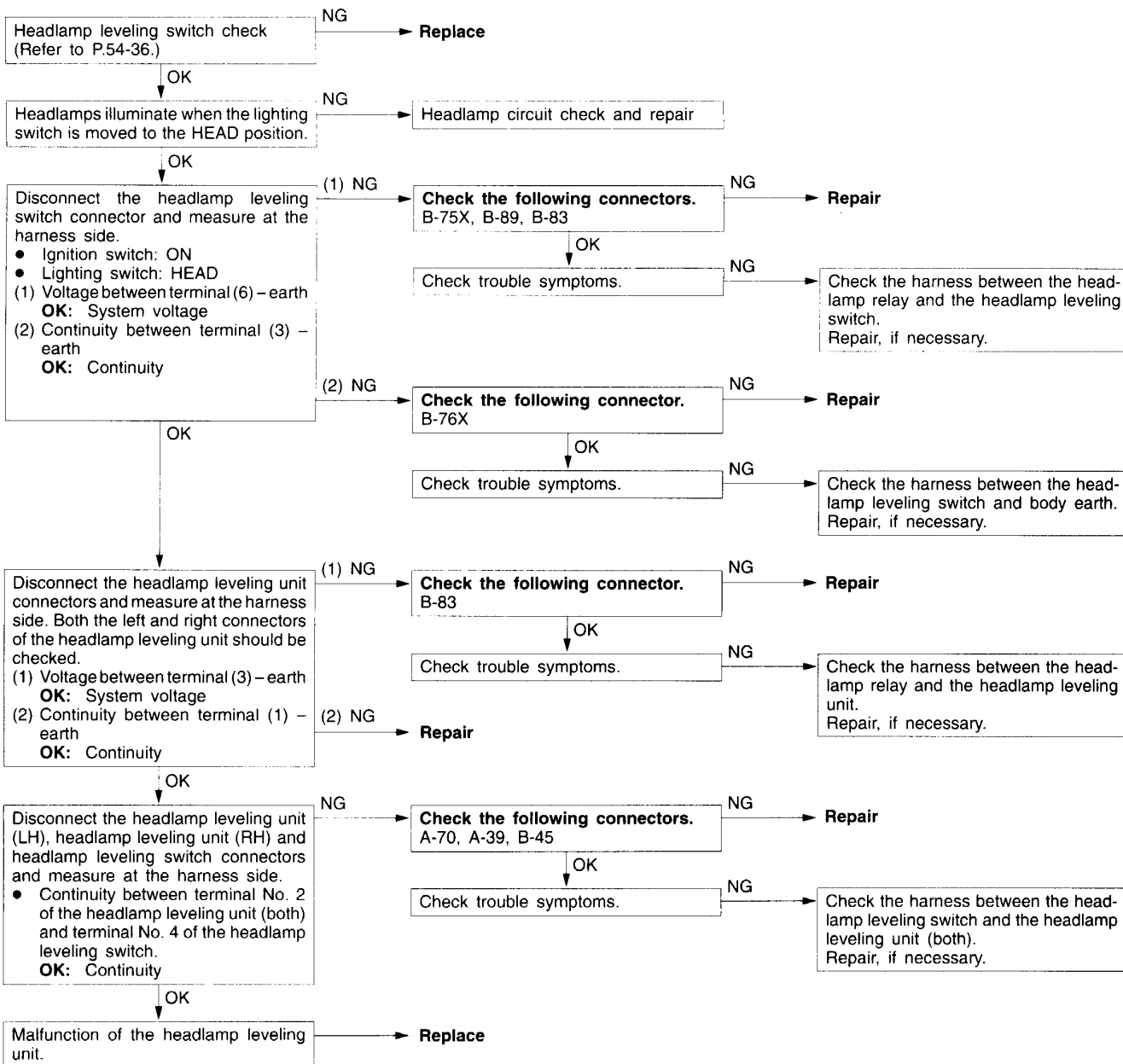

Inspection procedure 4

<p>The headlamps do not illuminate when the vehicle is in the following condition and the ignition switch is moved to the ON position. However, they illuminate when the lighting switch is moved to the HEAD position. <Vehicles with daytime running lamp></p> <ul style="list-style-type: none"> ● Lighting switch: OFF ● Passing switch: OFF 	<p>Probable cause</p>
<p>The cause is probably a malfunction of the daytime running lamp control unit (DRL-ECU) circuit system. If there is a blown fuse, there may also be a short-circuit in a harness.</p>	<ul style="list-style-type: none"> ● Malfunction of fuse ● Malfunction of connector ● Malfunction of harness ● Malfunction of the DRL relay (1) ● Malfunction of the DRL-ECU

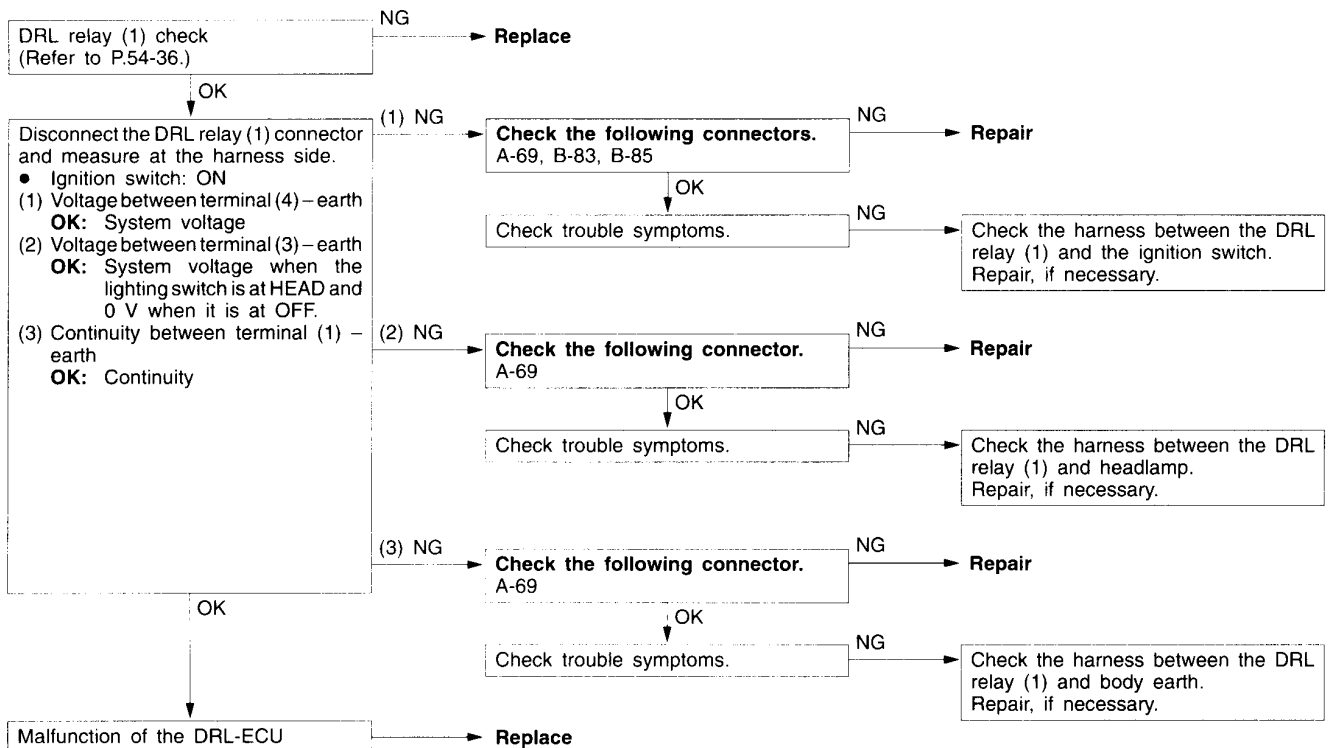

54-30 CHASSIS ELECTRICAL – Headlamp and Front Turn-signal Lamp

Inspection procedure 5

<p>The headlamps do not switch off when the vehicle is in the following condition and the lighting switch is moved to the TAIL position. <Vehicles with daytime running lamp></p> <ul style="list-style-type: none"> ● Ignition switch: OFF ● Passing switch: OFF 	<p>Probable cause</p>
<p>The cause is probably a malfunction of the daytime running lamp control unit (DRL-ECU) circuit system. If there is a blown fuse, there may also be a short-circuit in a harness.</p>	<ul style="list-style-type: none"> ● Malfunction of fuse ● Malfunction of connector ● Malfunction of harness ● Malfunction of the tail lamp relay ● Malfunction of the DRL-ECU

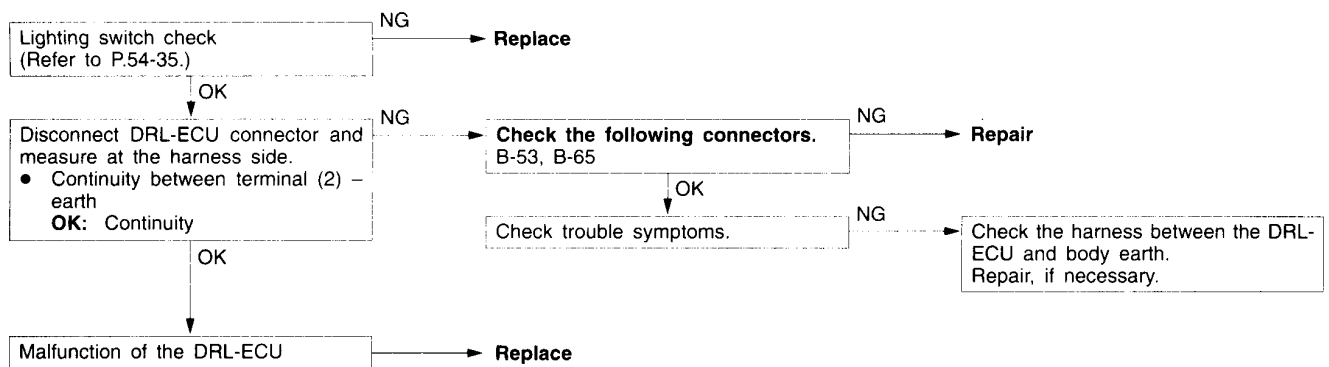

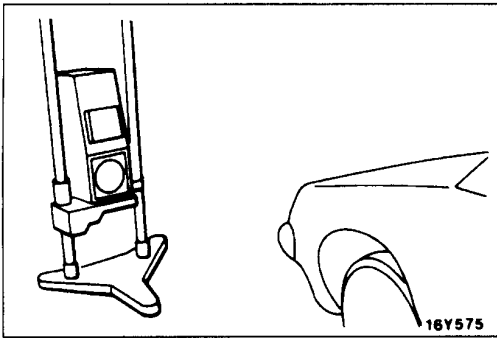

ON-VEHICLE SERVICE

54200090036

HEADLAMP AIMING

<USING A BEAMSETTING EQUIPMENT>

1. The headlamps should be aimed with the proper beamsetting equipment, and in accordance with the equipment manufacturer's instructions.

NOTE

If there are any regulations pertinent to the aiming of headlamps in the area where the vehicle is to be used, adjust so as to meet those requirements.

2. Alternately turn the adjusting screw to adjust the headlamp aiming. (Refer to P.54-32.)

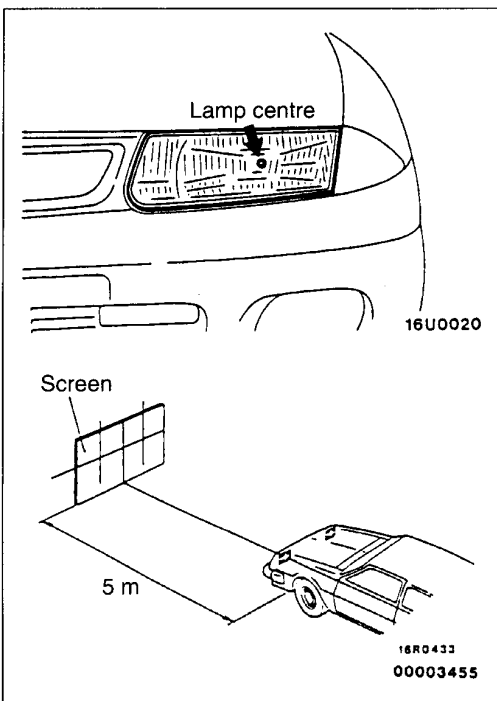

<USING A SCREEN>

1. Inflate the tyres to the specified pressures and there should be no other load in the vehicles other than driver or substituted weight of approximately 75 kg placed in driver's position.
2. Set the distance between the screen and the centre marks of the headlamps as shown in the illustration.

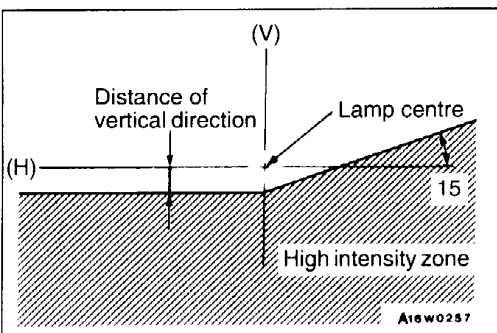

3. Check if the beam shining onto the screen is at the standard value.

Standard value:

(Vertical direction)

60 mm below horizontal (H)

(Horizontal direction)

Position where the 15° sloping section intersects the vertical line (V)

54-32 CHASSIS ELECTRICAL – Headlamp and Front Turn-signal Lamp

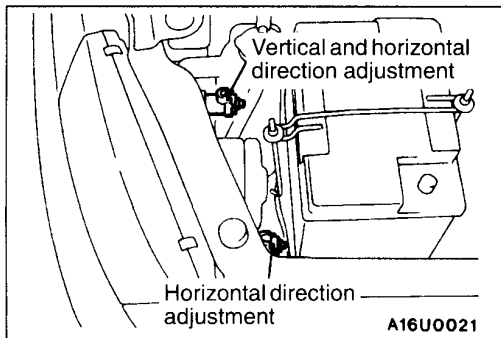

4. Alternately turn the adjusting screw to adjust the headlamp aiming.

Caution

Be sure to adjust the aiming adjustment screw in the tightening direction.

INTENSITY MEASUREMENT

54200100036

Using a photometer, and following its manufacture's instruction manual, measure the headlamp intensity and check to be sure that the limit value is satisfied.

Limit: 30,000 cd or more

NOTE

1. When measuring the intensity, maintain an engine speed of 2,000 r/min, with the battery in the charging condition.
2. There may be special local regulations pertaining to headlamp intensity, be sure to make any adjustments necessary to satisfy such regulations.
3. If an illuminometer is used to make the measurements, convert its values to photometer values by using the following formula.

$I = Er^2$ Where: I = intensity (cd)
 E = illumination (lux)
 r = distance (m) from headlamps to illuminometer

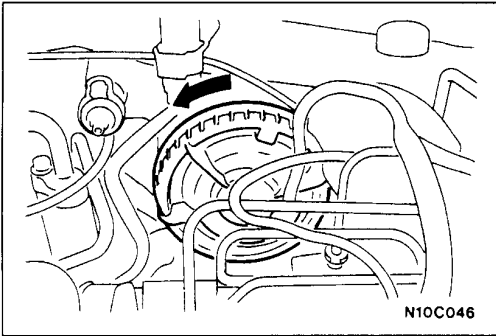
**BULB REPLACEMENT**

54200130035

<Headlamp Bulb>

1. Remove the sealing cover by turning it anti-clockwise and disconnect the connector.

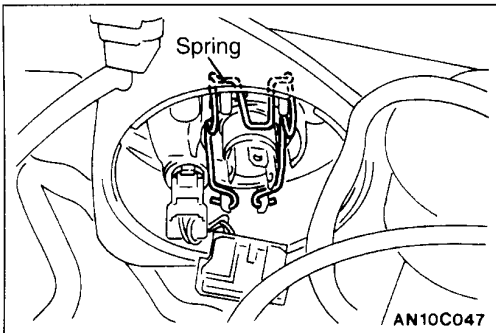

2. Unhook the spring which secures the bulb, and then remove the bulb.

Caution

Do not touch the surface of the bulb with hands or dirty gloves. If the surface does become dirty, clean it with alcohol or thinner, and let it dry thoroughly before installing.

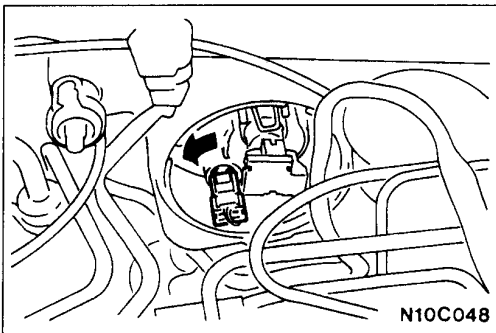
**<Position Lamp Bulb>**

1. Remove the sealing cover by turning it anti-clockwise.
2. Remove the lamp socket by turning it anti-clockwise, then pull out the bulb from the socket.

HEADLAMP AND FRONT TURN-SIGNAL LAMP

54200240028

REMOVAL AND INSTALLATION

Pre-removal and Post-installation Operation

- Removal and installation of radiator reserve tank (When replacing only left side headlamp).

CAUTION: SRS

Before removal of air bag module and clock spring, refer to GROUP 52B – Service Precautions and Air Bag Module and Clock Spring.

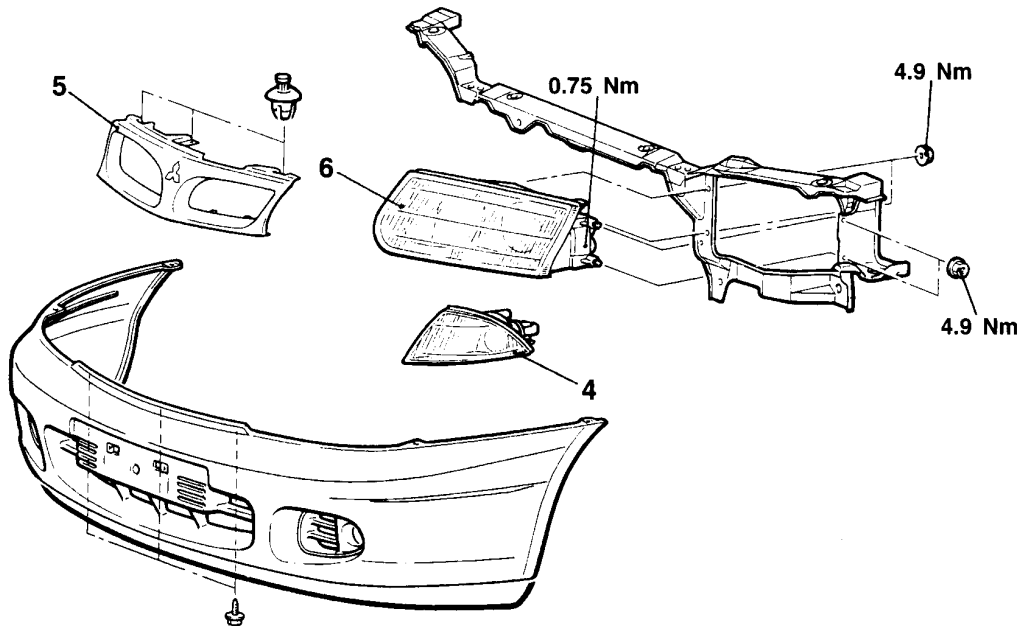

16U0034

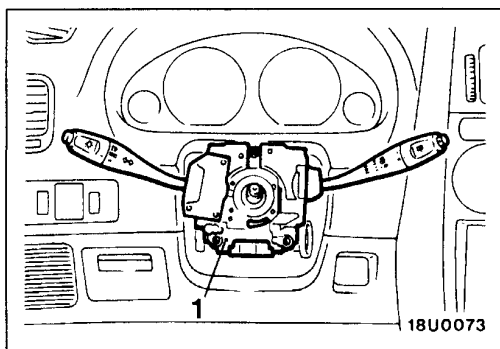

18U0073

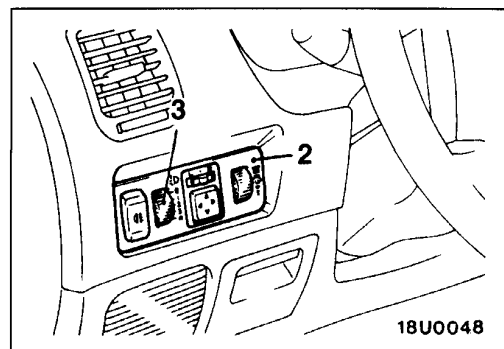

18U0048

00003456

1. Column switch <Lighting switch and dimmer/passing switch> (Refer to GROUP 37A – Steering Wheel and Shaft.)

Headlamp leveling switch removal steps

2. Switch garnish
3. Headlamp leveling switch

Headlamp removal steps

4. Front turn-signal lamp
5. Radiator grille (Refer to GROUP 51 – Front Bumper.)
6. Headlamp

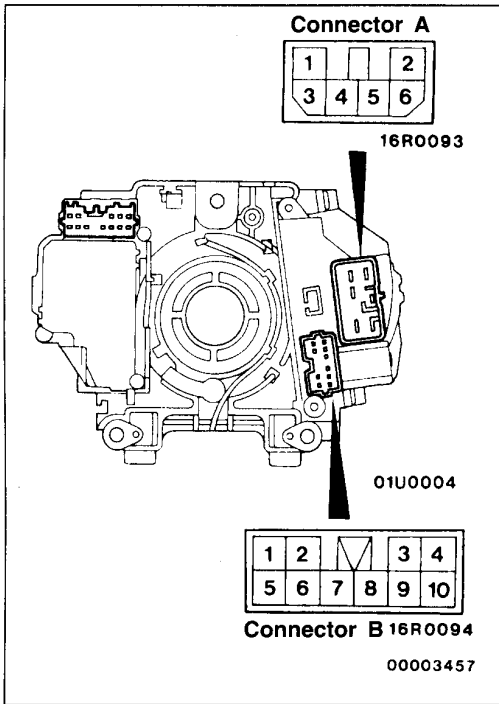

INSPECTION

54200250014

LIGHTING SWITCH, DIMMER/PASSING SWITCH AND TURN-SIGNAL LAMP SWITCH CHECK

Switch position	Connector A—terminal No.					Connector B—terminal No.					
	1	2	3	4	6	3	5	6	7	8	9
LIGHTING SWITCH	OFF										
	TAIL						○	—	○		
	HEAD	○						○	—	○	
DIMMER/PASSING SWITCH	LOWER			○	○						
	UPPER				○	○					
	PASSING	○	○		○	○					
TURN-SIGNAL LAMP SWITCH	RH										○
	OFF										
	LH						○	—	○		

NOTE

- *1 indicates continuity when the dimmer switch is in the lower position.
- *2 indicates continuity when the dimmer switch is in the upper position.

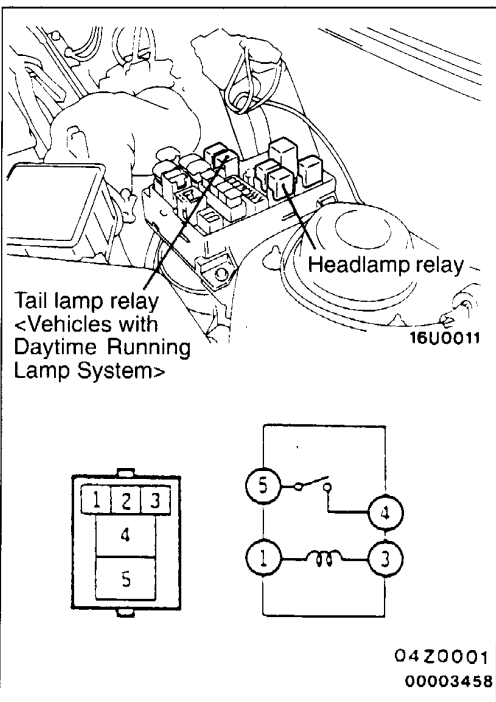

HEADLAMP RELAY AND TAIL LAMP RELAY CHECK

Battery voltage	Terminal No.			
	1	3	4	5
Supplied	⊕	⊖	○	○
Not supplied	○	○		

54-36 CHASSIS ELECTRICAL – Headlamp and Front Turn-signal Lamp

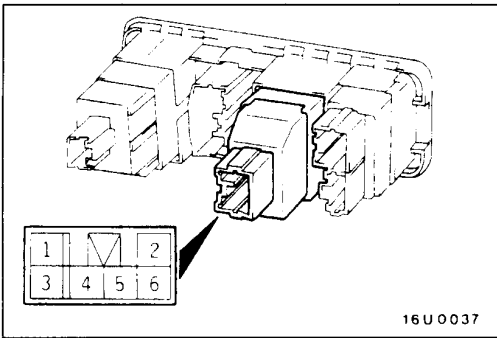

HEADLAMP LEVELING SWITCH CHECK

Check the resistance between the terminals when the headlamp leveling switch is operated.

Standard value:

Resistance measurement terminal No.	Switch position				
	0	1	2	3	4
Between 3 and 4 Ω	1,235	1,114	977	862	747
Between 4 and 6 Ω	548	669	806	921	1,036
Between 3 and 6 Ω	1,003				

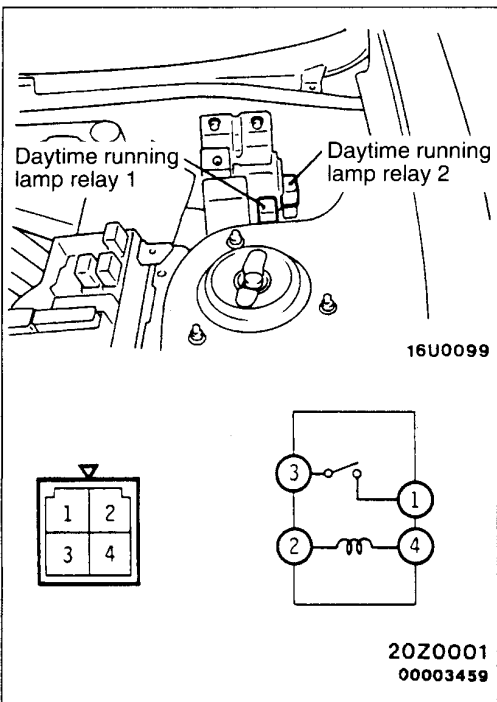

DAYTIME RUNNING LAMP RELAY I AND II CHECK

Battery voltage	Terminal No.			
	1	2	3	4
Supplied	○		○	
Not supplied		⊕		⊖

SIDE TURN-SIGNAL LAMP

5420060105

SPECIAL TOOL

Tool	Number	Name	Use
	MB990784	Ornament remover	Removal of side turn-signal lamp

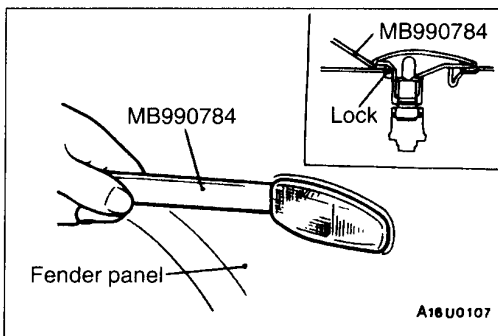

REMOVAL SERVICE POINT

54200330022

◀A▶ SIDE TURN-SIGNAL LAMP REMOVAL

Use a special tool to remove the lock from the fender panel, and then remove the side turn-signal lamp.

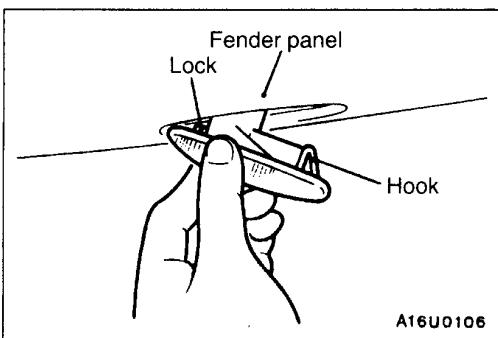

INSTALLATION SERVICE POINT

▶A◀ SIDE TURN-SIGNAL LAMP INSTALLATION

- (1) Fit the lock into the fender panel.
- (2) Push the side turn-signal lamp into the fender, and secure it with the hook.

FRONT FOG LAMP

54200030069

SERVICE SPECIFICATIONS

Items		Standard value
Front fog lamp aiming	Vertical direction	100 mm below horizontal (H)
	Horizontal direction	Parallel to direction of vehicle travel

SPECIAL TOOL

54200060112

Tool	Number	Name	Use
	MB990784	Ornament remover	Removal of switch garnish

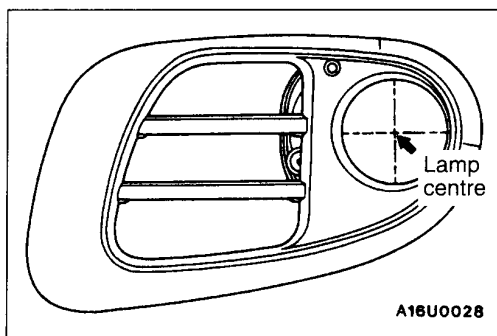

ON-VEHICLE SERVICE

54200110039

FRONT FOG LAMP AIMING

- (1) Measure the centre of the fog lamps, as shown in the illustration.

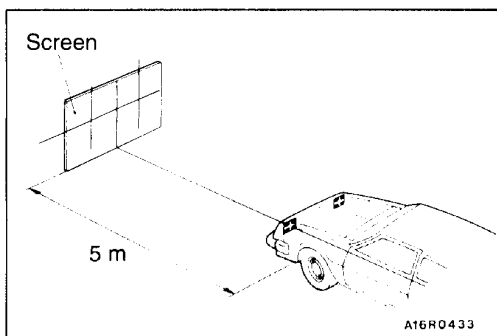

- (2) Set the distance between the screen and the centre of the fog lamps as shown in the illustration.
- (3) Inflate the tyres to the specified pressures and there should be no other load in the vehicles other than driver or substituted weight of approximately 75 kg placed in the driver's position.
- (4) With the engine running at 2,000 r/min, aim the fog lamp.

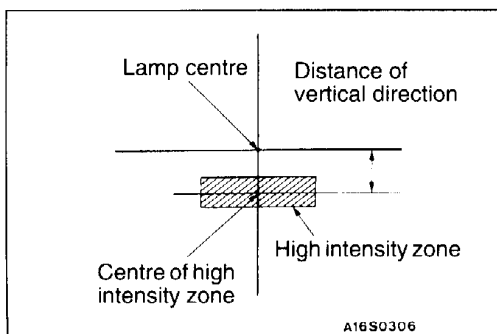

- (5) Check if the beam shining onto the screen is at the standard value.

Standard value:

(Vertical direction)

100 mm below horizontal (H)

(Horizontal direction)

Parallel to direction of vehicle travel

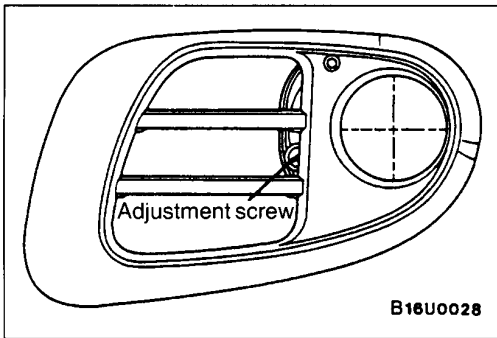
**NOTE**

The horizontal direction is non-adjustable. If the deviation of the light beam axis exceeds the standard value, check to be sure that the mounting location or some other point is not defective.

Caution

When making the aiming adjustment, be sure to mask those lamps which are not being adjusted.

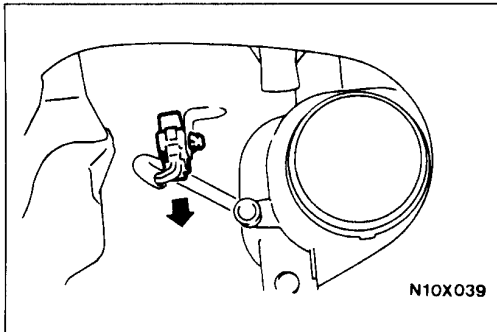
**BULB REPLACEMENT**

54200130042

- (1) Remove the fog lamp cover.
- (2) Disconnect the connector which is secured to the fog lamp bracket.

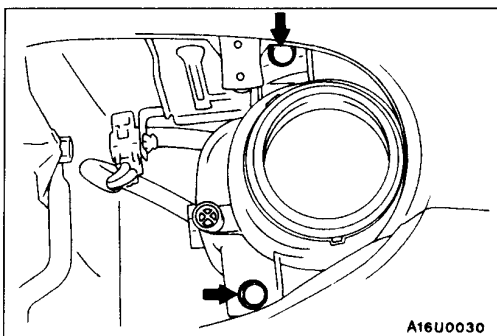

- (3) Remove the fog lamp unit.

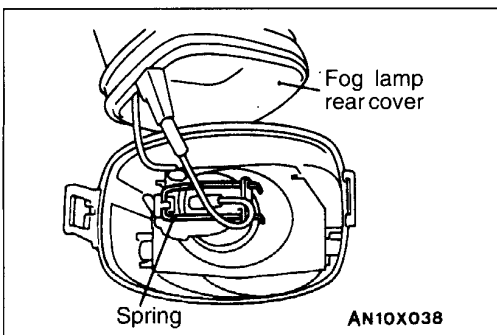

- (4) Undo the fog lamp rear cover.
- (5) Unhook the spring which secures the bulb and then remove the bulb.

Caution

Do not touch the surface of the bulb with hands or dirty gloves. If the surface does become dirty, clean it with alcohol or thinner, and let it dry thoroughly before installing.

**FRONT FOG LAMP
REMOVAL AND INSTALLATION**

54200150031

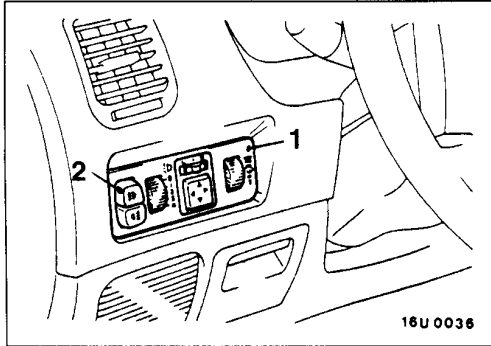

Front fog lamp switch removal steps

1. Switch garnish
2. Front fog lamp switch

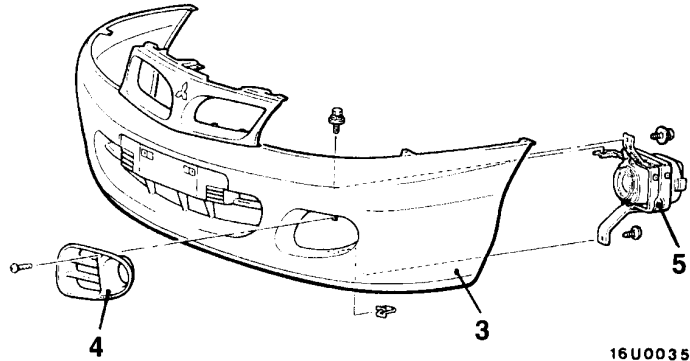

Front fog lamp removal steps

3. Front bumper
(Refer to GROUP 51.)
4. Fog lamp cover
5. Front fog lamp assembly

NOTE

For the fog lamp unit removal procedure, refer to P.54-39.

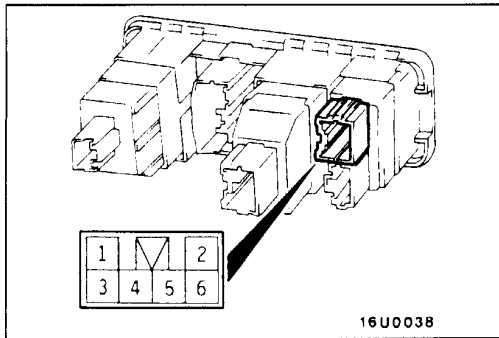

INSPECTION

54200160010

FRONT FOG LAMP SWITCH CONTINUITY CHECK

Switch position	Terminal No.					
	1	2	3	4	5	6
OFF	○	ILL ⊕	○			
ON	○	ILL ⊕	○	○	○	○

REAR COMBINATION LAMP, REAR LID LAMP

5420060129

SPECIAL TOOL

Tool	Number	Name	Use
	MB990784	Ornament remover	Removal of switch garnish

REAR COMBINATION LAMP, REAR LID LAMP

54200450032

REMOVAL AND INSTALLATION

Caution: SRS
 Before removal of air bag module and clock spring, refer to GROUP 52B – SRS Service Precautions and Air Bag Module and Clock Spring.

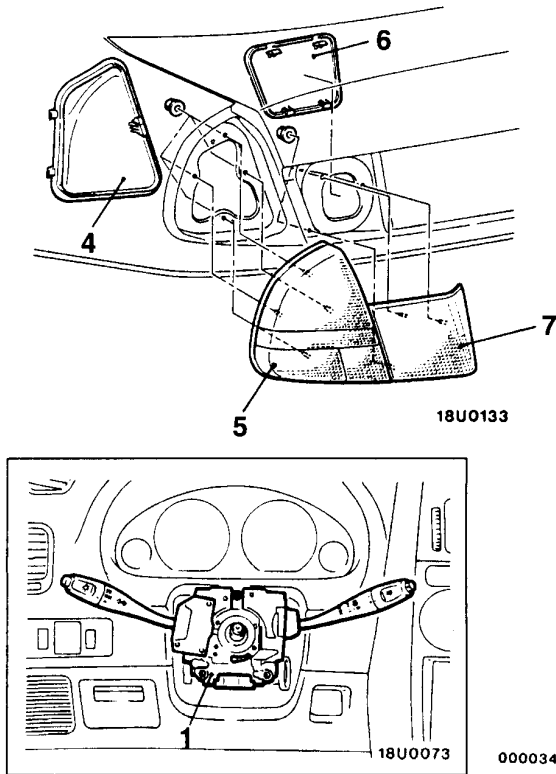
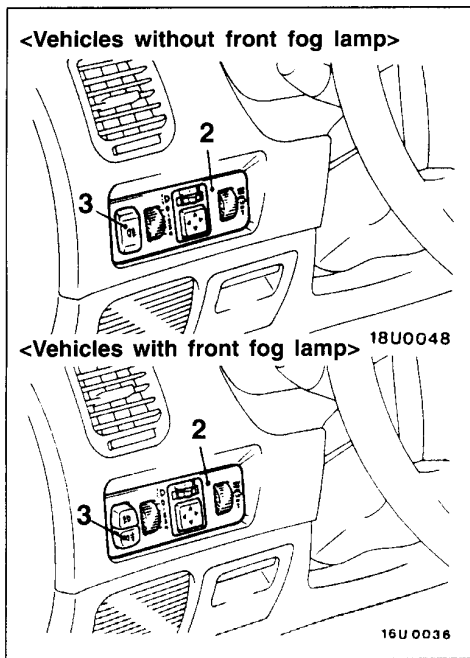

1. Column switch <Lighting switch and turn-signal lamp switch> (Refer to GROUP 37A – Steering Wheel and Shaft.)

Rear fog lamp switch removal steps

2. Switch garnish
3. Rear fog lamp switch

Rear combination lamp removal steps

4. Lamp lid
5. Rear combination lamp assembly

Rear lid lamp removal steps

6. Lamp lid
7. Rear lid lamp assembly

54-42 CHASSIS ELECTRICAL – Rear Combination Lamp, Rear Lid Lamp

54200460011

INSPECTION

REAR FOG LAMP SWITCH CHECK

Switch position	Terminal No.			
	1	2	3	4
OFF			○ — ○	ILL — ○
ON	○ — ○		○ — ○	ILL — ○

REAR FOG LAMP RELAY CHECK

Battery voltage	Terminal No.			
	1	3	4	5
Supplied	⊕ — ○	○ — ○	○ — ○	○ — ○
Not supplied	○ — ○	○ — ○		

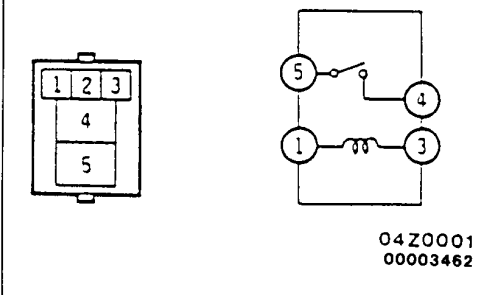
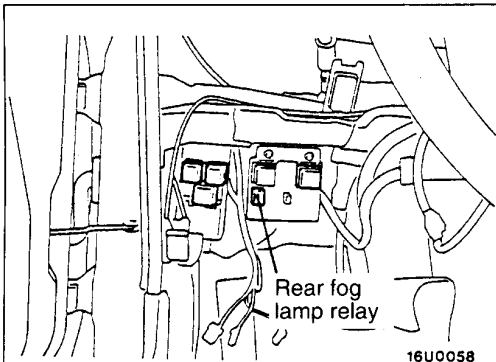
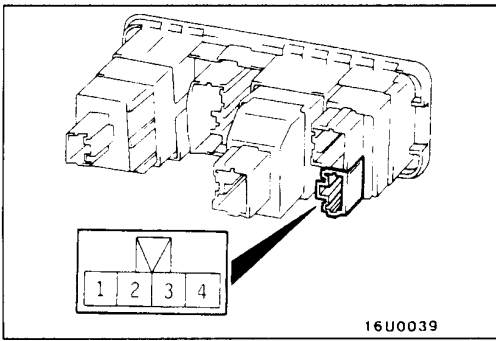

LIGHTING SWITCH AND TURN-SIGNAL LAMP SWITCH CHECK

Refer to P.54-35.

TAIL LAMP RELAY CHECK <Vehicles with Daytime Running Lamp System>

Refer to P.54-35.

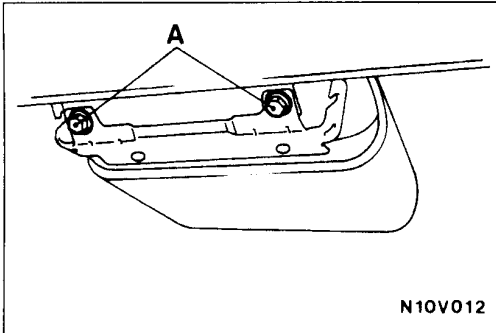
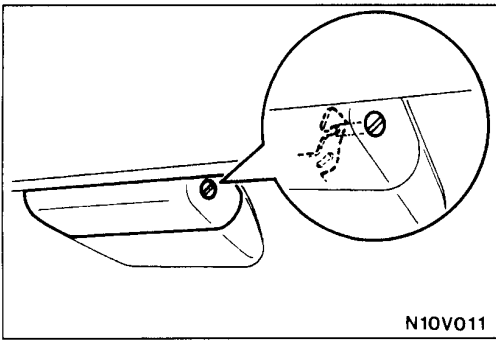

HIGH MOUNTED STOP LAMP

54200510037

REMOVAL SERVICE POINT

HIGH MOUNTED STOP LAMP REMOVAL

1. Set so that the clip groove is facing as shown in the illustration, and then remove the cover.
2. Remove the two bolts (A) and then remove the high mounted stop lamp.

RHEOSTAT

5420060136

SPECIAL TOOL

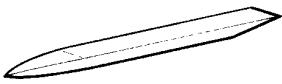
Tool	Number	Name	Use
	MB990784	Ornament remover	Removal of switch garnish

RHEOSTAT

5420060031

REMOVAL AND INSTALLATION

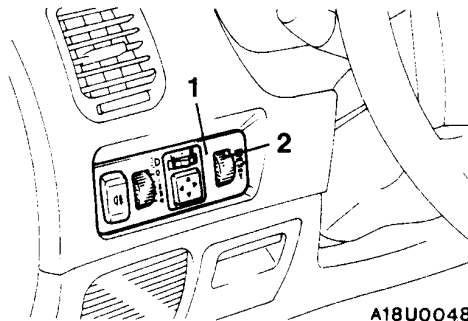

Removal steps

1. Switch garnish
2. Rheostat

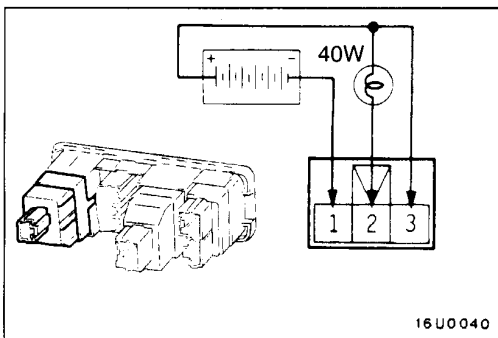

INSPECTION

54200610034

- (1) Connect the battery and the test bulb (40W) as shown in the illustration.
- (2) Operate the rheostat, and if the brightness changes smoothly without switching off, then the rheostat function is normal.

HAZARD WARNING LAMP SWITCH

54200660039

REMOVAL AND INSTALLATION

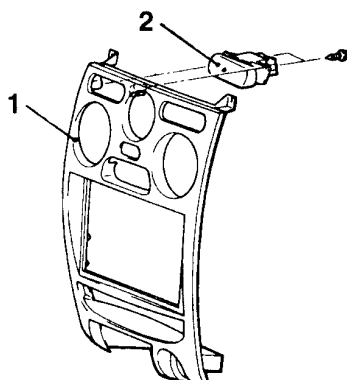

A16U0047

Removal steps

1. Center console panel
(Refer to GROUP 52A – Floor Console.)
2. Hazard warning lamp switch

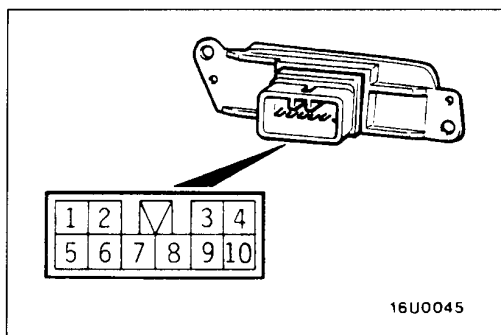

16U0045

INSPECTION

54200670049

Switch position	Terminal No.									
	1	2	3	5	6	7	8	9	10	
OFF		○	ILL ⊕	○	○	—	○			
ON	○	○	ILL ⊕	○		○	○	○	○	○

CIGARETTE LIGHTER

54300560035

REMOVAL AND INSTALLATION

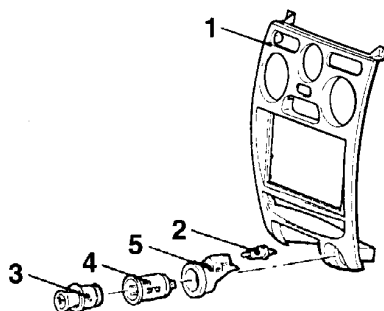

A16U0048

Removal steps

1. Center console panel
(Refer to GROUP 52A – Floor Console.)
2. Bulb
3. Plug
4. Socket
5. Socket case

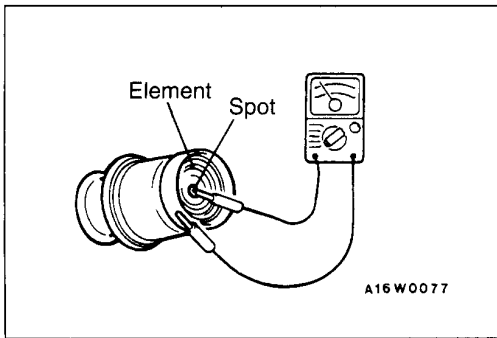
**INSPECTION**

54300570038

- Take out the plug, and check for a worn edge on the element spot connection, and for shreds of tobacco or other material on the element.
- Using a circuit tester, check the continuity of the element.

CAUTIONS FOR USE OF THE CIGARETTE LIGHTER SOCKET AS AUXILIARY POWER SOURCE

1. When using a "plug-in" type of accessory, do not use anything with a load of more than 120W.
2. It is recommended that only the lighter be inserted in the receptacle.
Use of "plug-in" type accessories may damage the receptacle and result in poor retention of the lighter.
3. The specified load should be strictly observed, because overloaded cord burns the ignition switch and harness.

CLOCK

54300590034

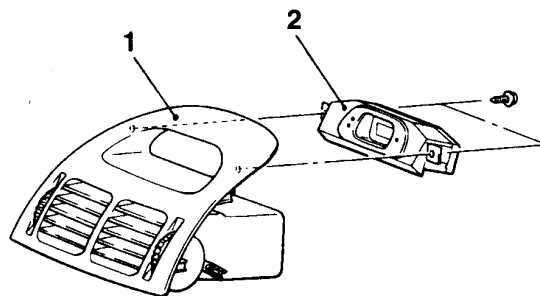
REMOVAL AND INSTALLATION

A16U0049

Removal steps

1. Center air outlet assembly
(Refer to GROUP 52A – Floor Console.)
2. Clock

RADIO AND TAPE PLAYER

54400070036

TROUBLESHOOTING**QUICK-REFERENCE TROUBLESHOOTING CHART**

Items	Problem symptom	Relevant chart
Noise	Noise appears at certain places when travelling (AM).	A-1
	Noise appears at certain places when travelling (FM).	A-2
	Mixed with noise, only at night (AM).	A-3
	Broadcasts can be heard but both AM and FM have a lot of noise.	A-4
	There is more noise either on AM or on FM.	A-5
	There is noise when starting the engine.	A-6
	Some noise appears when there is vibration or shocks during travelling.	A-7
	Noise sometimes appears on FM during travelling.	A-8
	Ever-present noise.	A-9
Radio	When switch is set to ON, no power is available.	B-1
	No sound from one speaker.	B-2
	There is noise but no reception for both AM and FM or no sound from AM, or no sound from FM.	B-3
	Insufficient sensitivity.	B-4
	Distortion on AM or on both AM and FM.	B-5
	Distortion on FM only.	B-6
	Too few automatic select stations.	B-7
	Insufficient memory (preset stations are erased).	B-8

NOTE

Refer to problem symptoms of AM radio for MW radio.

Items	Problem symptom	Relevant chart
Tape player	Cassette tape will not be inserted.	C-1
	No sound.	C-2
	No sound from one speaker.	C-3
	Sound quality is poor, or sound is weak.	C-4
	Cassette tape will not be ejected.	C-5
	Uneven revolution. Tape speed is fast or slow.	C-6
	Faulty auto reverse.	C-7
	Tape gets caught in mechanism.	C-8

CHART

A. NOISE

A-1 Noise appears at certain places when travelling (AM).

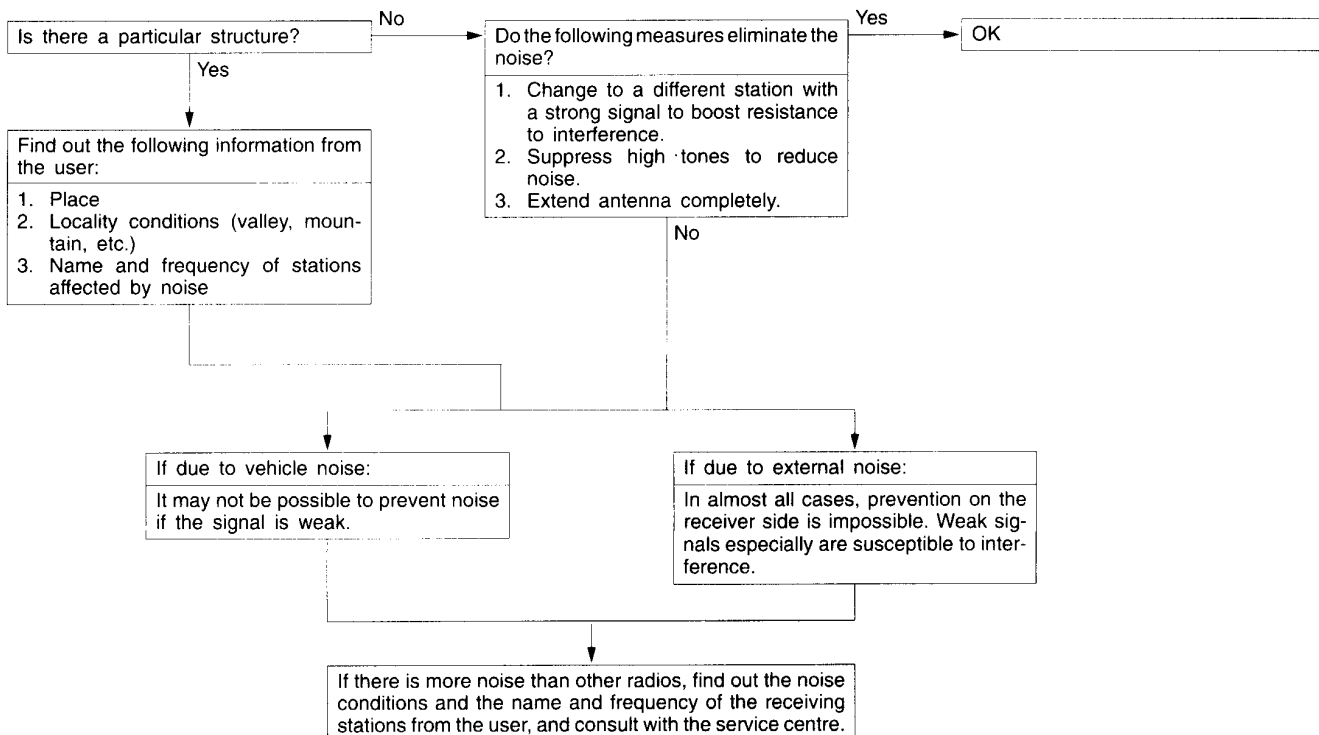

A-2 Noise appears at certain places when travelling (FM).

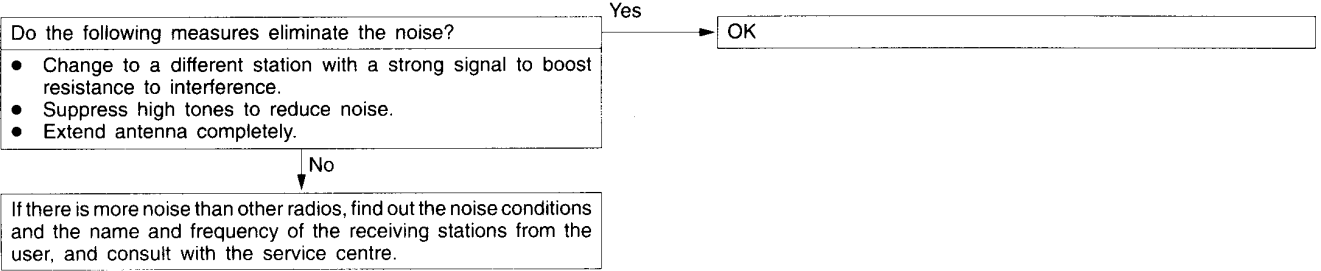

NOTE

About FM waves:

FM waves have the same properties as light, and can be deflected and blocked. Wave reception is not possible in the shadow of obstructions such as buildings or mountains.

1. The signal becomes weak as the distance from the station's transmission antenna increases. Although this may vary according to the signal strength of the transmitting station and intervening geographical formation or buildings, the area of good reception is approx. 20–25 km for stereo reception, and 30–40 km for monaural reception.
2. The signal becomes weak when an area of shadow from the transmitting antenna (places where there are obstructions such as mountains or buildings between the antenna and the car), and noise will appear. <This is called first fading, and gives a steady buzzing noise.>

3. If a direct signal hits the antenna at the same time as a signal reflected by obstructions such as mountains or buildings, interference of the two signals will generate noise. During travelling, noise will appear each time the vehicle's antenna passes through this kind of obstructed area. The strength and interval of the noise varies according to the signal strength and the conditions of deflection. <This is called multipath noise, and is a repetitious buzzing.>
4. Since FM stereo transmission and reception has a weaker field than monaural, it is often accompanied by a hissing noise.

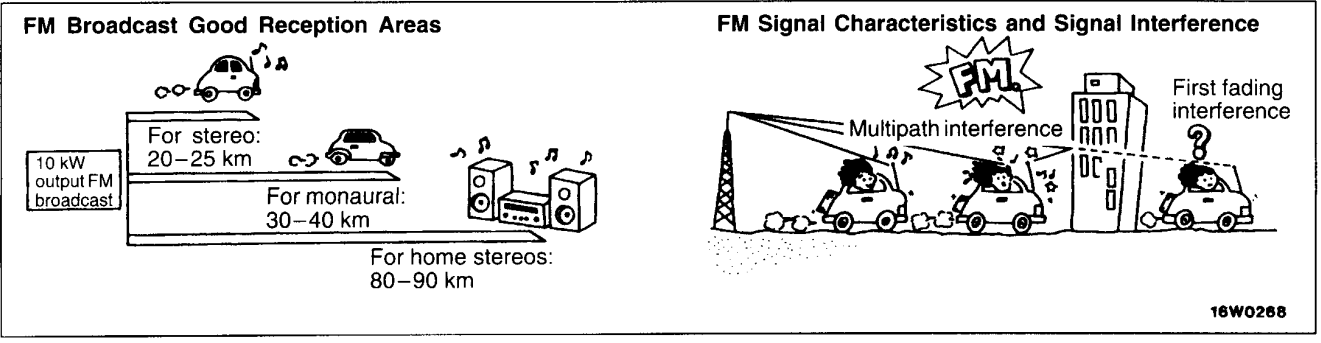

A-3 Mixed with noise, only at night (AM).

The following factors can be considered as possible causes of noise appearing at night.

1. Factors due to signal conditions: Due to the fact that long-distance signals are more easily received at night, even stations that are received without problem during the day may experience interference in a general worsening of reception conditions. The weaker a station is the more susceptible it is to interference,

and a change to a different station or the appearance of a beating sound* may occur. Beat sound*: Two signals close in frequency interfere with each other, creating a repetitious high-pitched sound. This sound is generated not only by sound signals but by electrical waves as well.

2. Factors due to vehicle noise: Alternator noise may be a cause.

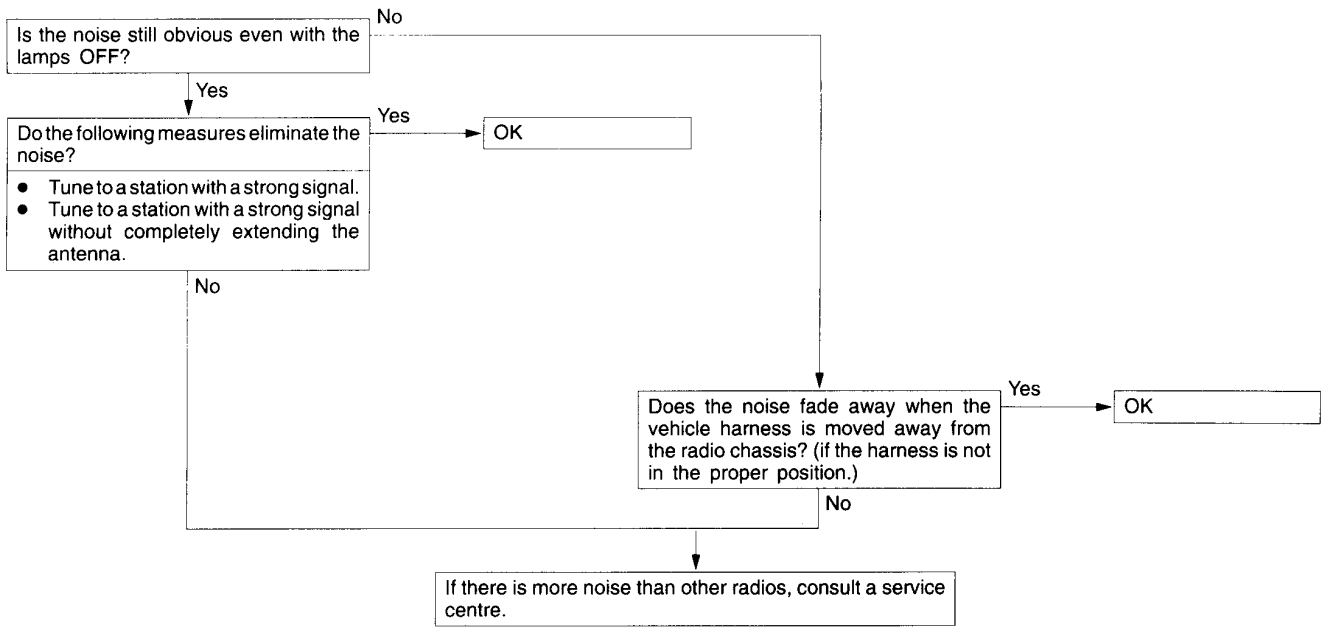

A-4 Broadcasts can be heard but both AM and FM have a lot of noise.

(1)

Noise occurs when the engine is stopped.

Yes

Do the following measures eliminate the noise?

- Tune to a station with a strong signal.
- Extend the antenna completely.
- Adjust the sound quality to suppress high tones.

Yes

OK

No

Is the radio body earth mounted securely?

No

Securely tighten the nuts for the body earth.

Yes

Is the antenna plug properly connected to the radio?

No

Correctly attach the antenna plug.

Yes

Is the antenna itself in good condition or is it properly mounted?

No

Clean the antenna plug and earth wire mounting area. Mount the antenna securely.

Yes

Is the noise eliminated?

Yes

OK

No

If there is more noise than other radios, consult a service centre.

(2)

Noise occurs when the engine in running.

Inspect the vehicle's noise suppressor. (Refer to A-6.)

NOTE

About noise encountered during FM reception only. Due to differences in FM and AM systems, FM is not as susceptible as AM to interference from engines, power lines, lightning, etc. On the other hand, there are cases due to the characteristics

of FM waves of noise or distortion generated by typical noise interference (first fading and multipath). (Refer to A-2.) <Noise (hissing) occurs in weak signal areas such as mountainous regions, but this is not due to a problem with the radio.>

A-5 There is more noise either on AM or on FM.

1. There is much noise only on AM.
Due to differences in AM and FM systems, AM is more susceptible to noise interference.

Were conditions such as the following present when noise was received?

- Lightning was flashing. A motorcycle was passing.
- A vehicle passed close by, but it appeared to be a vehicle generating a particularly large amount of noise radiation.
- Passed beneath a power line. Passed under a bridge.
- Passed beneath a telephone line.
- Passed close by a signal generator.
- Passed close by some other source of electrical noise.

Yes

No

Continue to check for static; when static is detected, check for the conditions listed above.

Yes

No

If the problem is particularly worse than other radios, consult a service centre.

Noise prevention on the radio side is difficult. If the problem is particularly worse than other radios, consult a service centre.

2. There is much noise only on FM.
Due to differences in FM and AM systems, FM is not as susceptible as AM to interference from engines, power lines, lightning, etc. On the other hand, there are cases due to the characteristics of FM waves of noise or

distortion generated by typical noise interference (first fading and multipath). (Refer to A-2) <Noise (hissing) occurs in weak signal areas such as mountainous regions, but this is not due to a problem with the radio.>

A-6 There is noise when starting the engine.

Noise type Sounds are in parentheses ().	Conditions	Cause	Remedy
AM, FM: Ignition noise (Popping, snapping, cracking, buzzing)	<ul style="list-style-type: none"> Increasing the engine speed causing the popping sound to speed up, and volume decreases. Disappears when the ignition switch is turned to ACC. 	<ul style="list-style-type: none"> Mainly due to the spark plugs. Due to the engine noise. 	<ul style="list-style-type: none"> Check or replace the earth cable. (Refer to Fig. 1 on P.54-54.) Check or replace the noise capacitor.
Other electrical components	–	Noise may appear as electrical components become older.	Repair or replace electrical components.
Static electricity (Cracking, crinkling)	<ul style="list-style-type: none"> Disappears when the vehicle is completely stopped. Severe when the clutch is engaged. 	Occurs when parts or wiring move for some reason and contact metal parts of the body.	Return parts or wiring to their proper position.
	<ul style="list-style-type: none"> Various noises are produced depending on the body part of the vehicle. 	Due to detachment from the body of the front hood, bumpers, exhaust pipe and muffler, suspension, etc.	Tighten the mounting bolts securely. Cases where the problem is not eliminated by a single response to one area are common, due to several body parts being imperfectly earthed.

Caution

1. **Connecting a high tension cable to the noise filter may destroy the noise filter and should never be done.**
2. **Check that there is no external noise. Since failure caused by this may result in misdiagnosis due to inability to identify the noise source, this operation must be performed.**
3. **Noise prevention should be performed by suppressing strong sources of noise step by step.**

NOTE

1. Capacitor
The capacitor does not pass D.C. current, but as the number of waves increases when it

passes A.C. current, impedance (resistance against A.C.) decreases, and current flow is facilitated. A noise suppressing condenser which takes advantage of this property is inserted between the power line for the noise source and the earth. This suppresses noise by earthing the noise component (A.C. or pulse signal) to the body of the vehicle.

2. Coil
The coil passes D.C. current, but impedance rises as the number of waves increases relative to the A.C. current. A noise suppressing coil which takes advantage of this property is inserted into the power line for the noise source, and works by preventing the noise component from flowing or radiating out of the line.

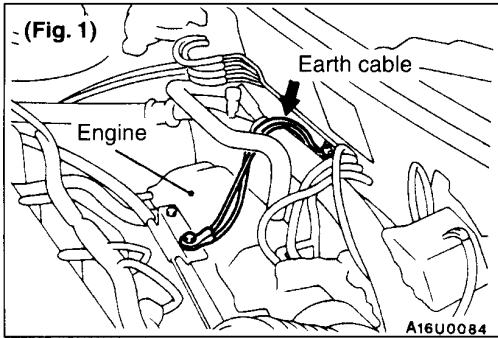

A-7 Some noise appears when there is vibration or shocks during travelling.

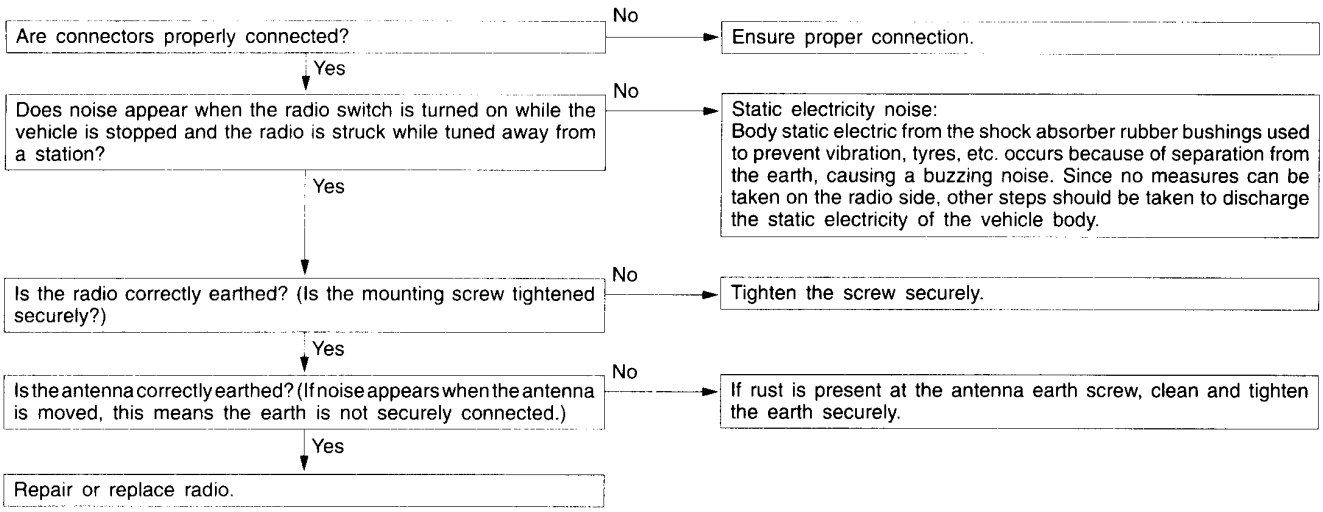

A-8 Noise sometimes appears on FM during travelling.

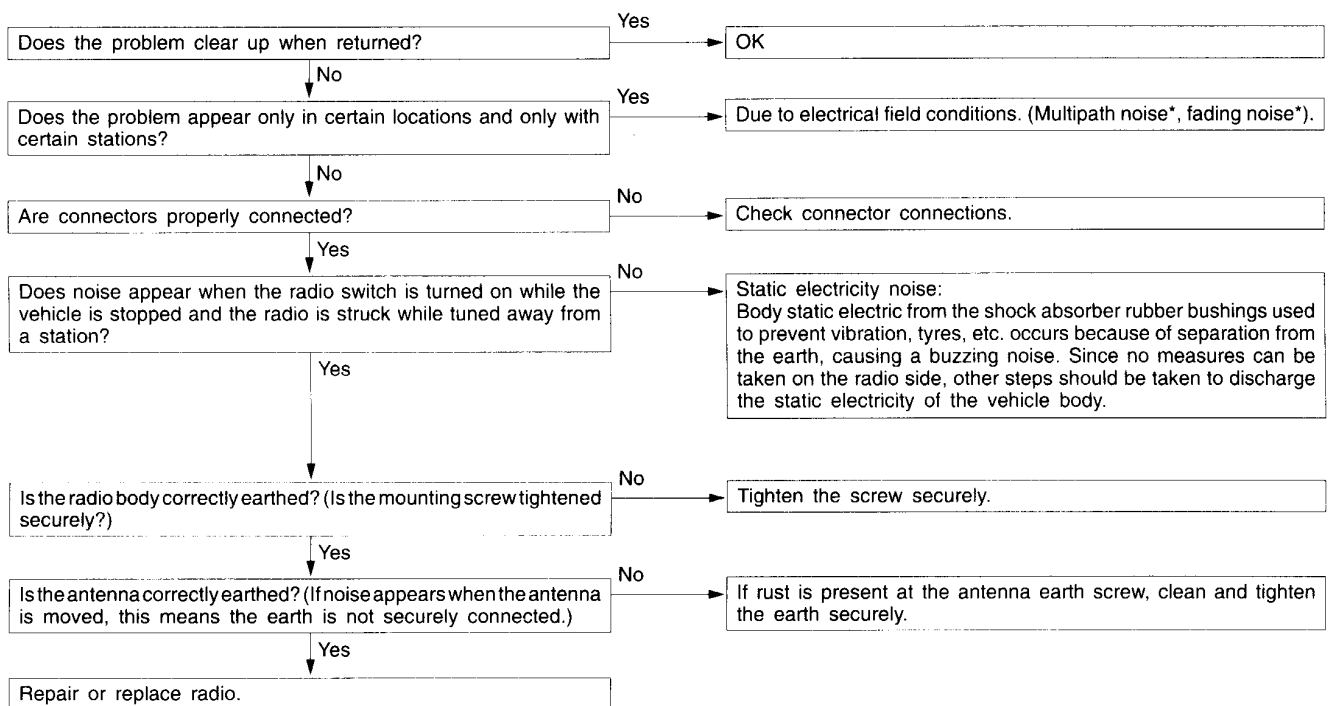

* About multipath noise and fading noise
 Because the frequency of FM waves is extremely high, it is highly susceptible to effects from geological formations and buildings. These effects disrupt the broadcast signal and obstruct reception in several ways.

- Multipath noise
 This describes the echo that occurs when the broadcast signal is reflected by a large

obstruction and enters the receiver with a slight time delay relative to the direct signal (repetitious buzzing).

- Fading noise
 This is a buzzing noise that occurs when the broadcast beam is disrupted by obstructing objects and the signal strength fluctuates intricately within a narrow range.

A-9 Ever-present noise.

Noise is often created by the following factors, and often the radio is OK when it is checked individually.

- Travelling conditions of the vehicle
- Terrain of area travelled through
- Surrounding buildings
- Signal conditions
- Time period

For this reason, if there are still problems with noise even after the measures described in steps A-1 to A-8 have been taken, get information on the factors listed above as well as determining whether the problem occurs with AM or FM, the station names, frequencies, etc., and contact a service centre.

B. RADIO

B-1 No power is supplied when the switch is set to ON.

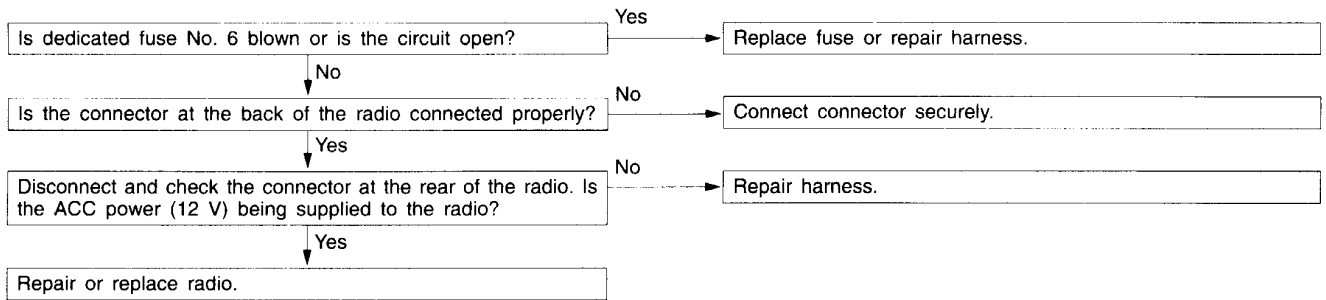

B-2 No sound from one speaker.

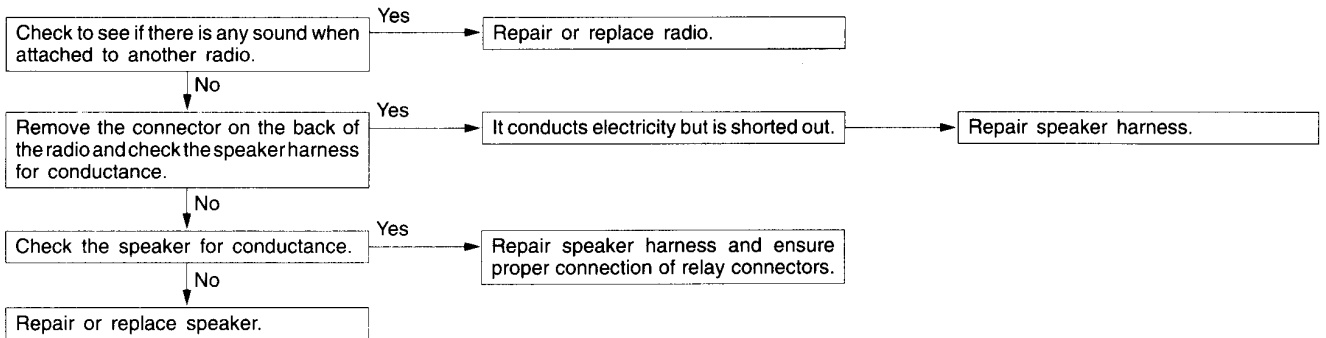

B-3 There is noise but no reception for both AM and FM or no sound from AM, or no sound from FM.

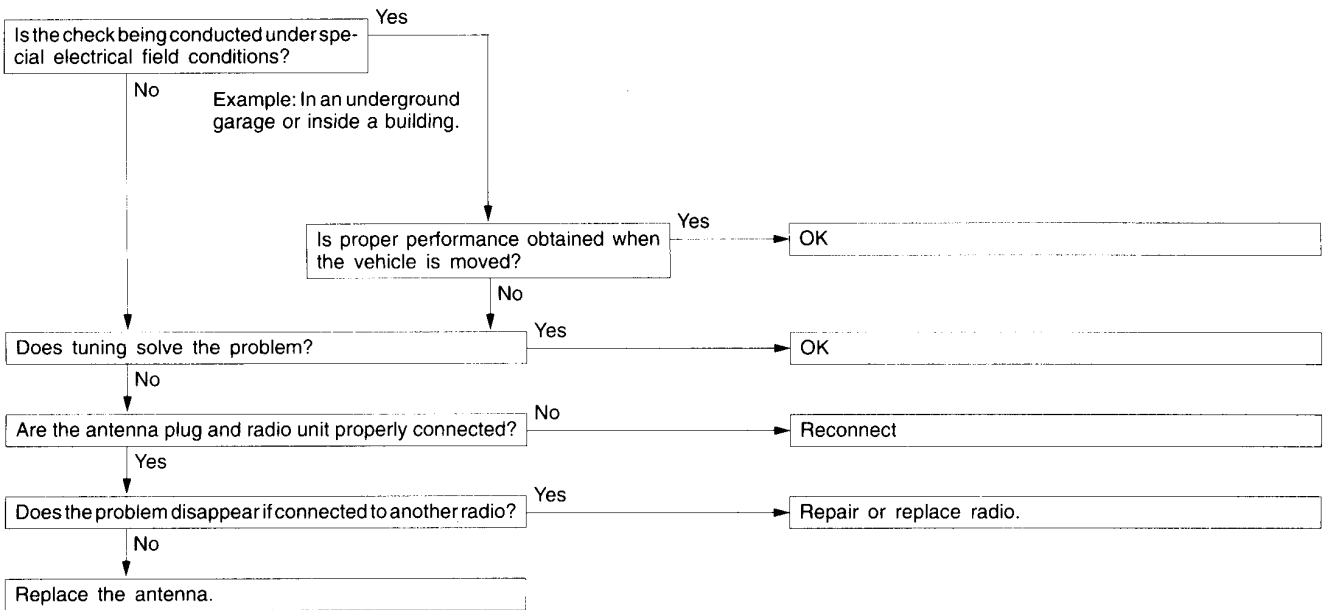

B-4 Insufficient sensitivity.

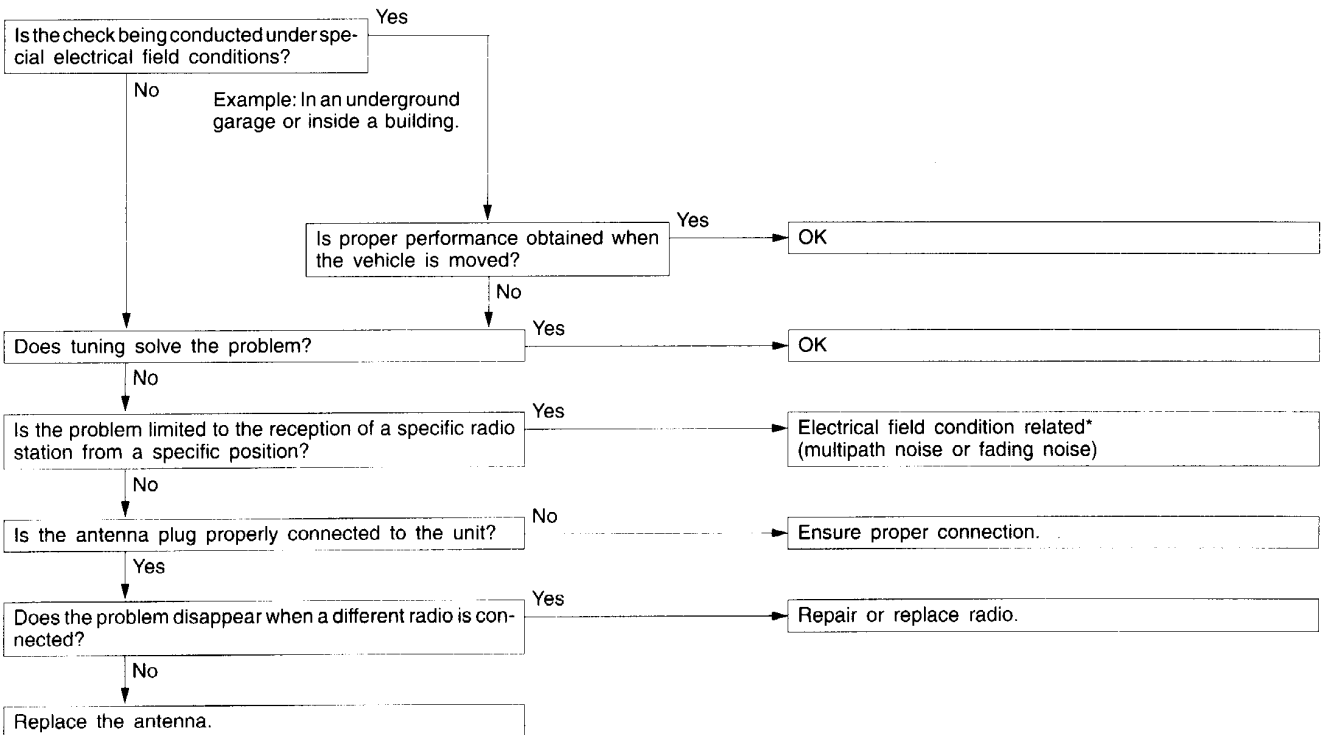

* For multipath noise and fading noise problems, refer to P. 54-55.

B-5 Distortion on AM or on both AM and FM.

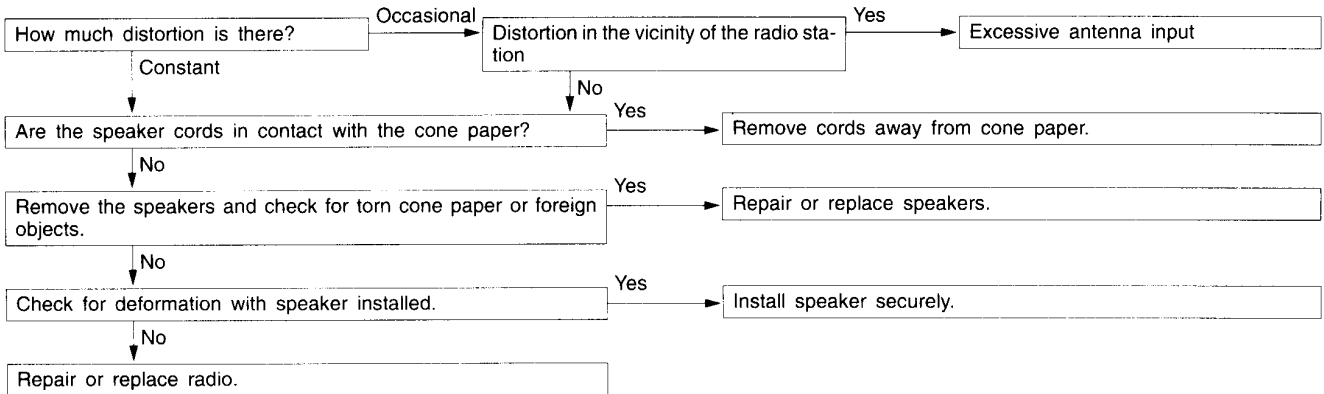

B-6 Distortion on FM only

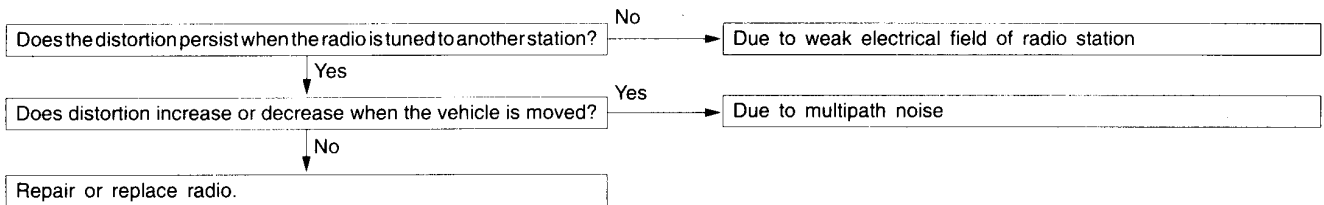

B-7 Too few automatic select stations.

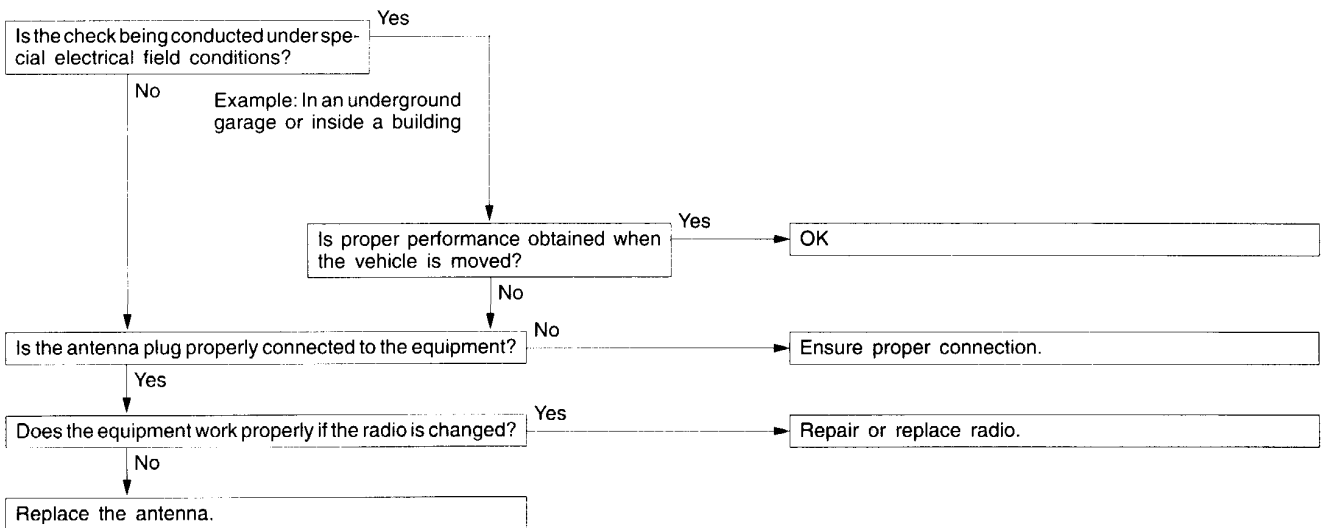

B-8 Insufficient memory (preset stations are erased).

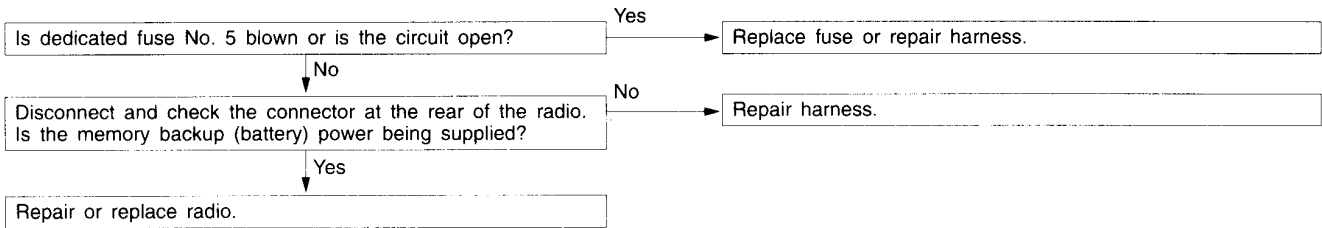

C. TAPE PLAYER

C-1 Cassette tape will not be inserted.

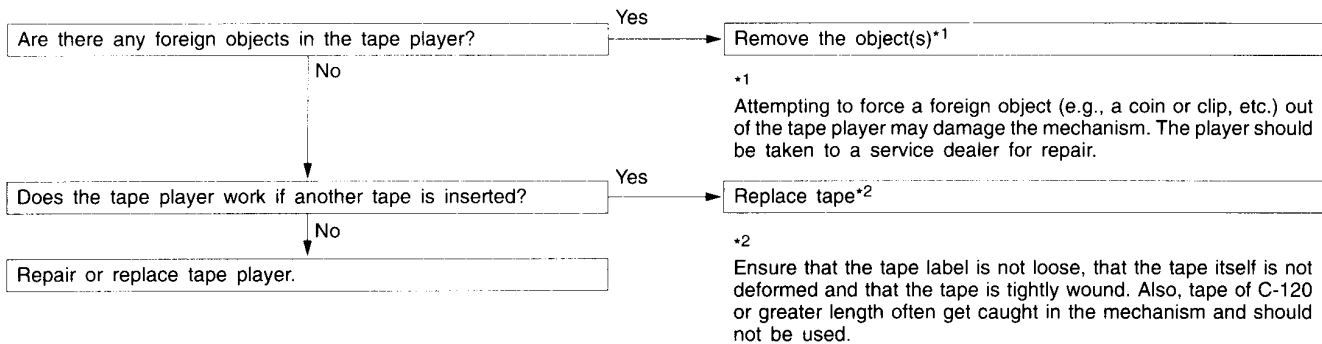

C-2 No sound (even after a tape has been inserted).

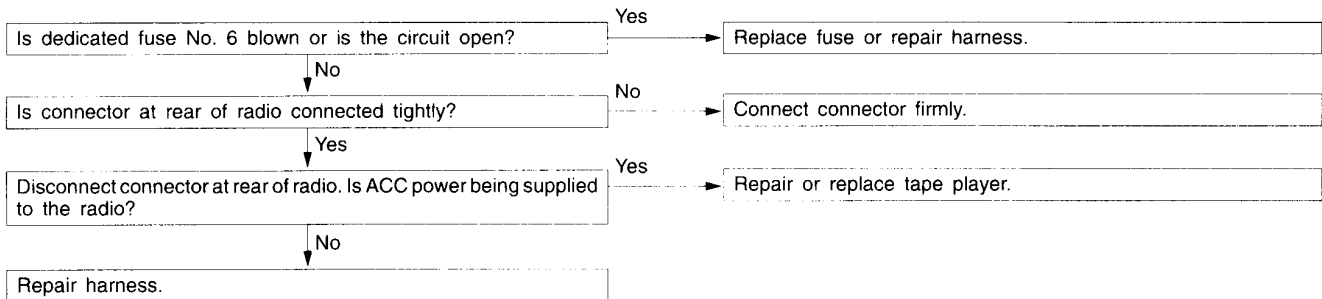

C-3 No sound from one speaker.

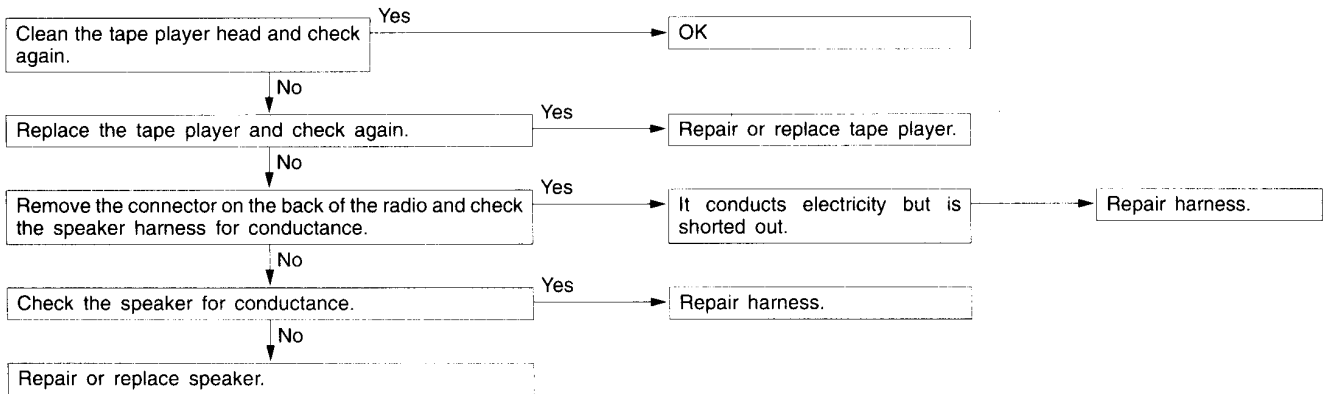

C-4 Sound quality is poor, or sound is weak.

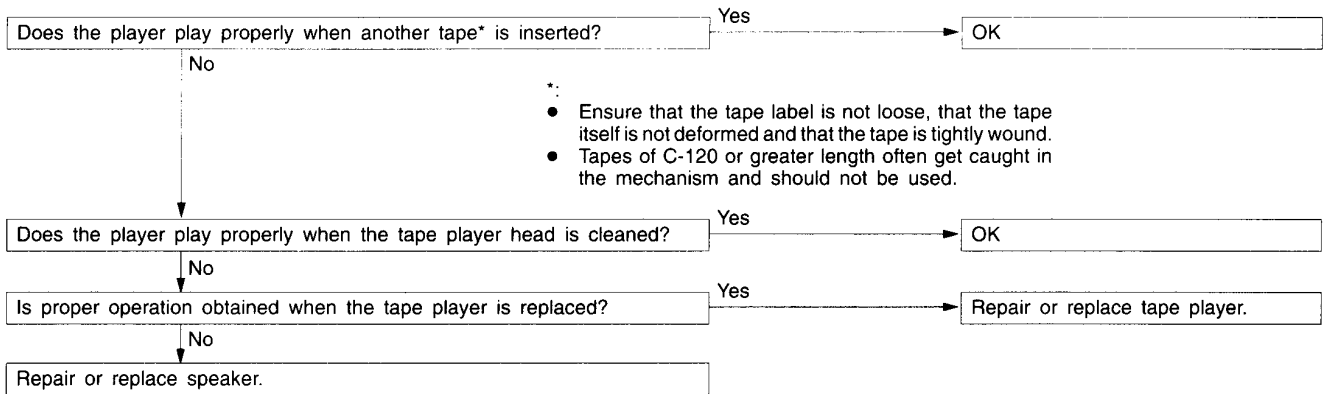

C-5 Cassette tape will not be ejected.

The problems covered here are all the result of the use of a bad tape (deformed or not properly tightened) or of a malfunction of the tape player itself. Malfunctions involving the tape becoming caught in the mechanism and ruining the case are

also possible, and attempting to force the tape out of the player can cause damage to the mechanism. The player should be taken to a service dealer for repair.

C-6 Uneven revolution. Tape speed is fast or slow.

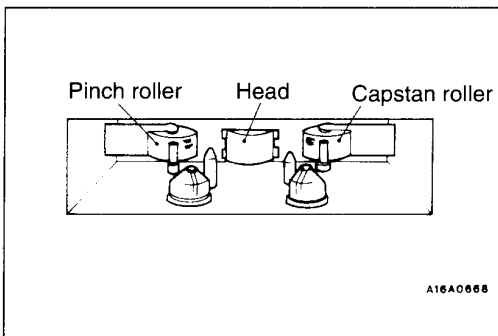
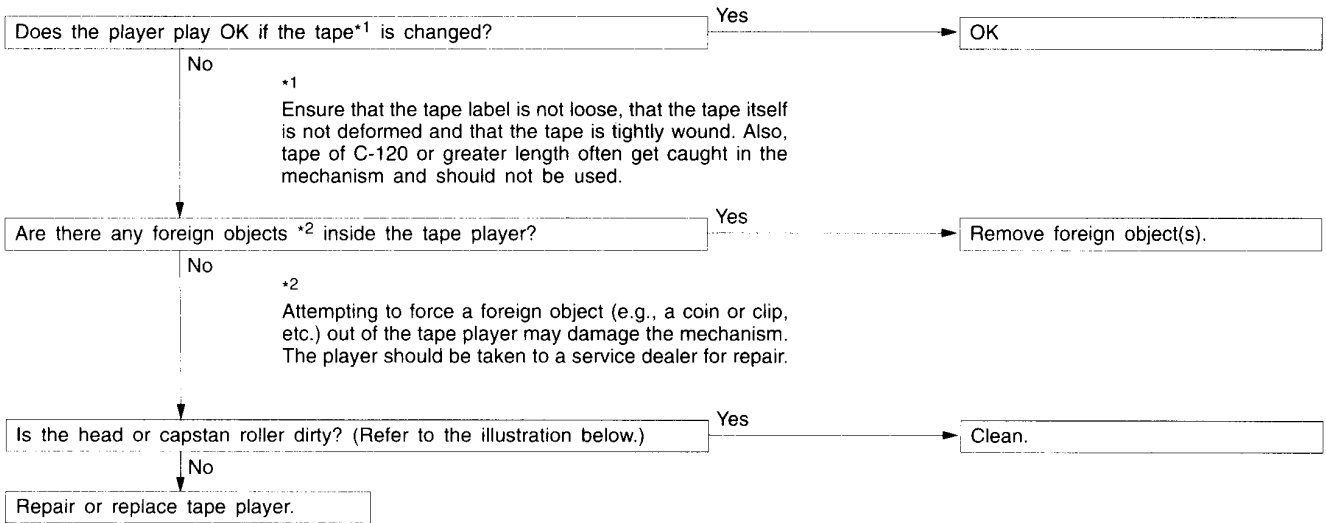

C-7 Faulty auto reverse.

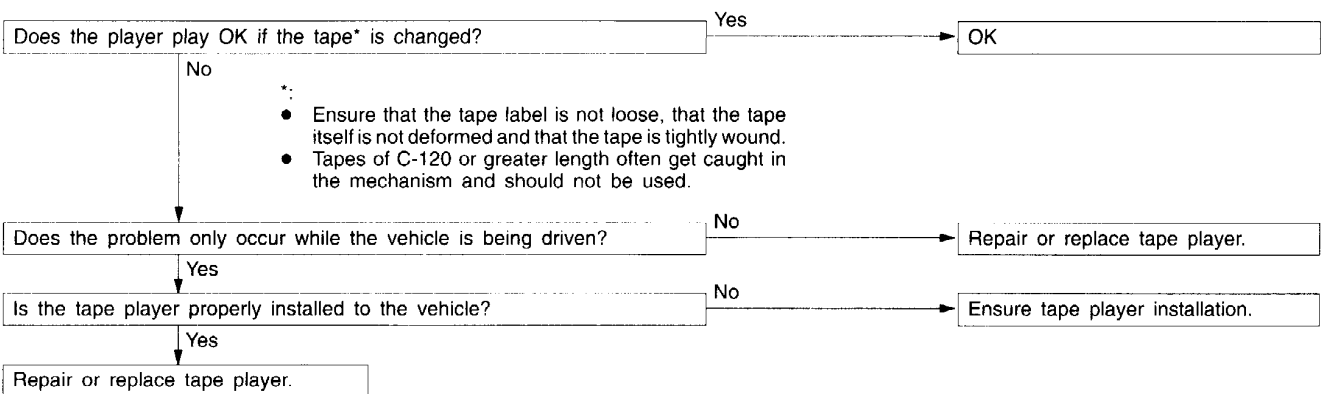

C-8 Tape gets caught in mechanism*1.

*1

When the tape is caught in the mechanism, the case may not eject. When this occurs, do not try to force the tape out as this may damage the tape player mechanism. Take the cassette to a service dealer for repair.

Does the player play OK if the tape*2 is changed?

Yes

Tape used is bad.

No

*2

Ensure that the tape label is not loose, that the tape itself is not deformed and that the tape is tightly wound. Also, tapes of C-120 or greater length often get caught in the mechanism and should not be used.

Repair or replace tape player.

RADIO AND TAPE PLAYER REMOVAL AND INSTALLATION

54400140027

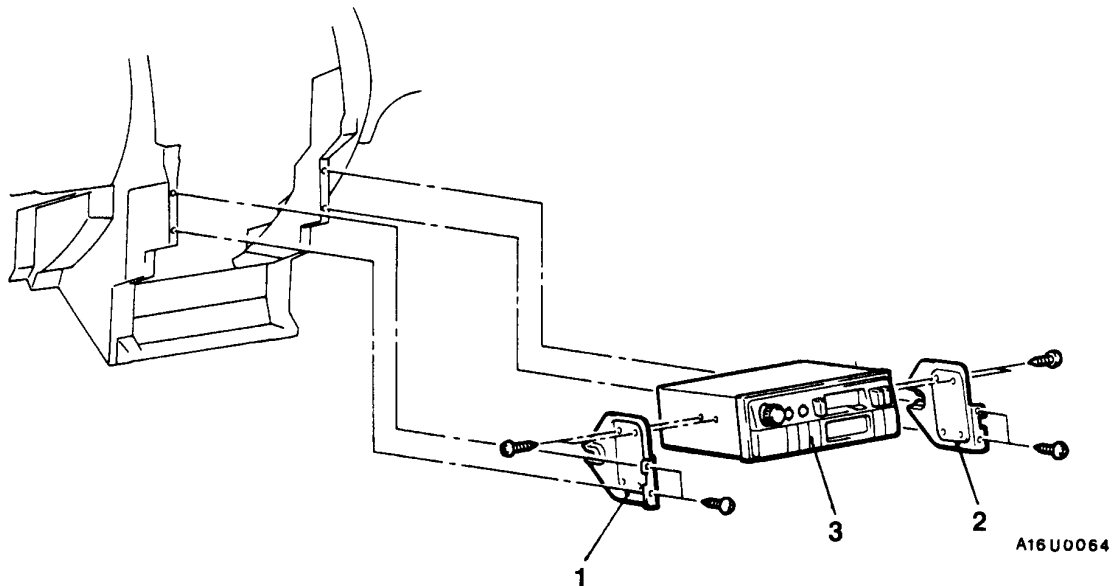

Removal steps

- Centre console panel
(Refer to GROUP 52A – Floor Console.)
- 1. Radio bracket (LH)
- 2. Radio bracket (RH)
- 3. Radio and tape player

SPEAKER

54400260051

REMOVAL AND INSTALLATION

<Driver's Side>

<Front Passenger's Side>

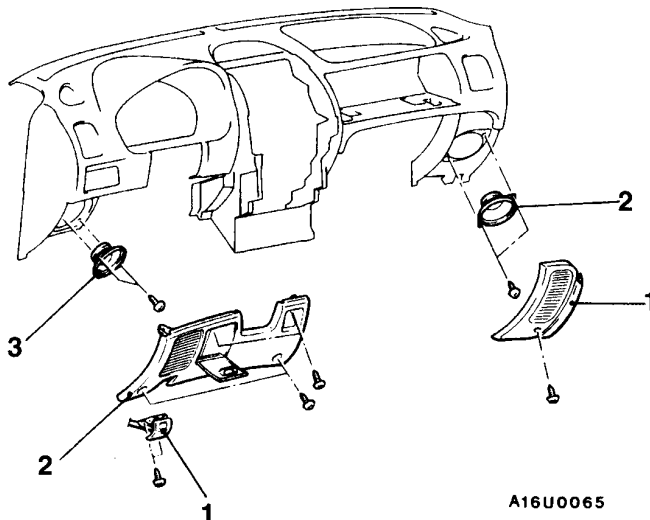

A16U0065

Removal steps

<Driver's Side>

1. Hood lock release handle
2. Instrument under cover
3. Speaker

<Front Passenger's Side>

1. Corner panel
2. Speaker

<Rear Side>

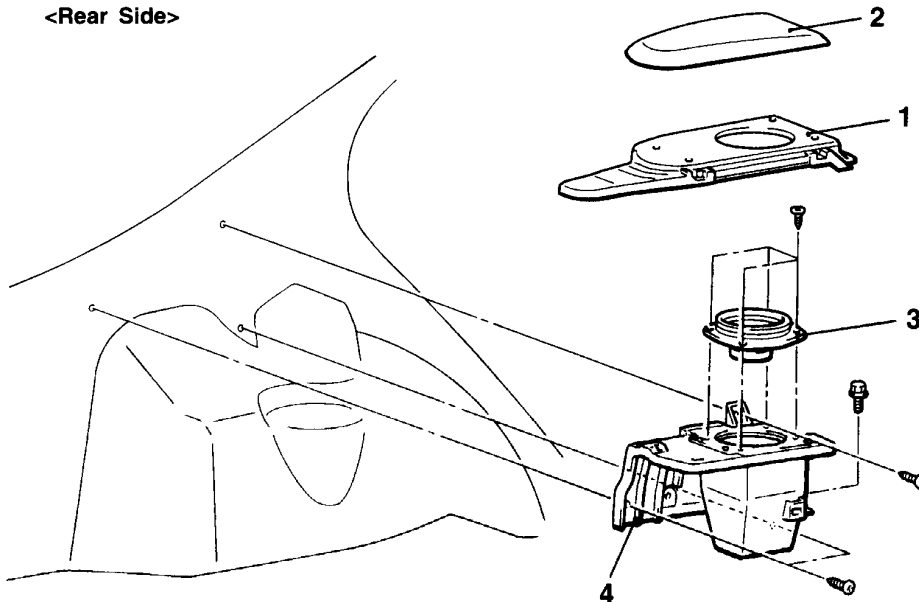

A16U0068

Removal steps

1. Side shelf
2. Speaker garnish
3. Speaker
- Rear side trim (Refer to GROUP 52A.)
4. Speaker bracket

ANTENNA

54400290043

POLE ANTENNA

REMOVAL AND INSTALLATION

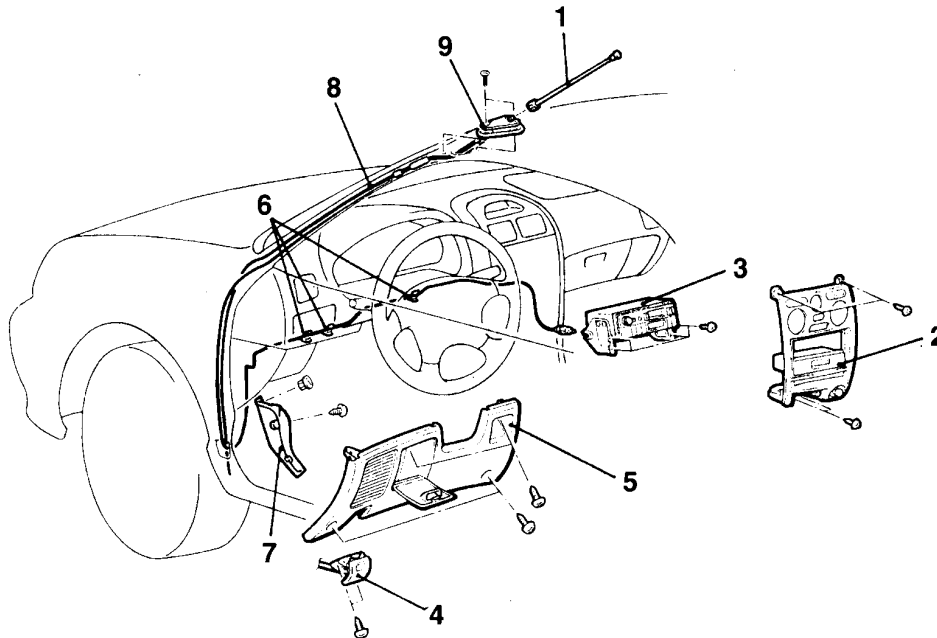

A16U0066

Removal steps

- | | | |
|---|------------|--|
| <ol style="list-style-type: none"> 1. Pole 2. Center console panel
(Refer to GROUP 52A – Floor Console.) 3. Radio and tape player 4. Hood lock release handle 5. Instrument under cover
(Refer to GROUP 52A – Instrument Panel.) | <p>◀A▶</p> | <ol style="list-style-type: none"> 6. Clip 7. Cowl side trim
(Refer to GROUP 52A.) 8. Antenna base 9. Base |
|---|------------|--|

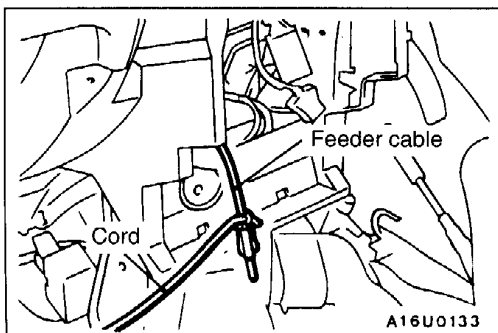

REMOVAL SERVICE POINT

◀A▶ ANTENNA BASE REMOVAL

- (1) Tie a cord to the end of the feeder cable.

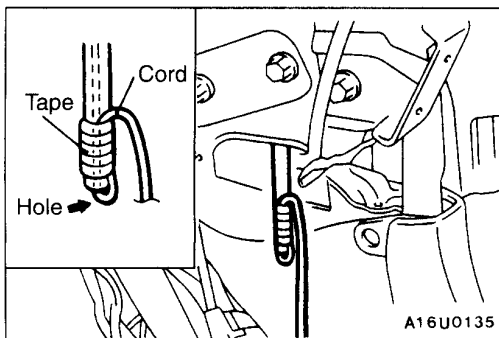

- (2) Pull out the antenna base until the end of the drain pipe can be seen.
- (3) Pass the cord through the hole in the end of the drain pipe and wrap it with vinyl tape.

Caution

Wrap it securely so that the cord will not come off.

- (4) Pull out the antenna base little by little to remove it.

MOTOR ANTENNA

54400350024

REMOVAL AND INSTALLATION**CAUTION: SRS**

When removing and installing the floor console assembly from vehicles equipped with SRS, do not let it bump against the SRS-ECU or other components.

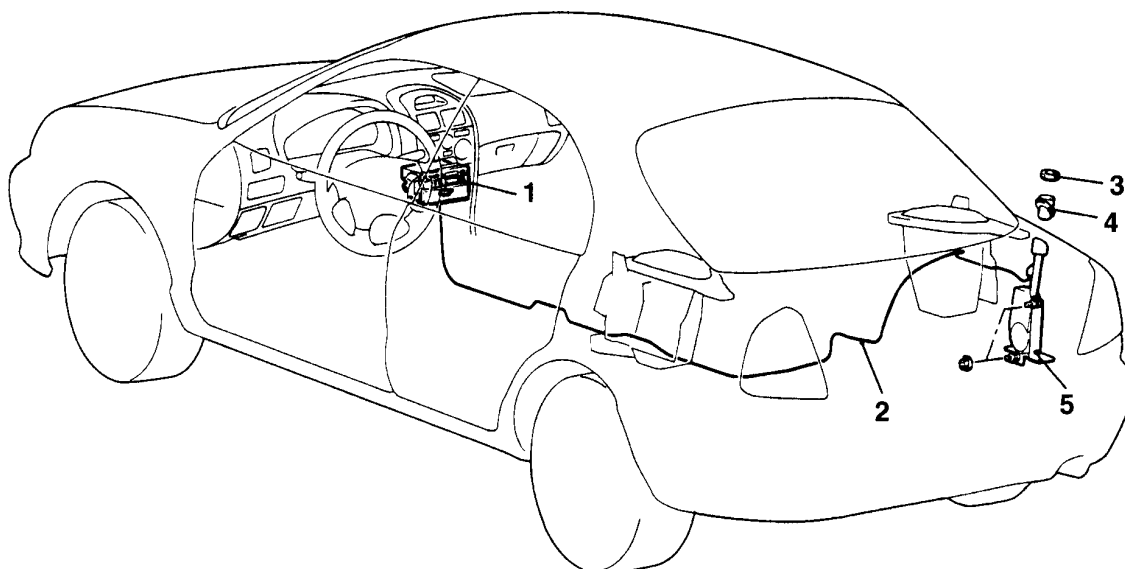

A16U0067

Antenna feeder cable removal steps

1. Radio and tape player (Refer to P.54-62.)
 - Front and rear floor console assembly (Refer to GROUP 52A.)
 - Front seat assembly (R.H.) (Refer to GROUP 52A.)
 - Rear seat cushion and side seatback assembly (R.H.) (Refer to GROUP 52A.)
 - Cowl side trim (R.H.), front scuff plate (R.H.), rear scuff plate (R.H.), center pillar lower trim (R.H.) and rear side trim (R.H.) (Refer to GROUP 52A.)
 - Speaker bracket (Refer to P.54-63.)
2. Antenna feeder cable

Motor antenna assembly removal steps

- Rear side trim (R.H.) (Refer to GROUP 52A.)
- 3. Ring nut
- 4. Base
- 5. Motor antenna assembly

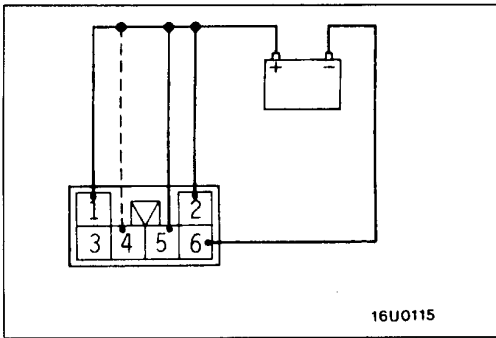
**INSPECTION**

54400360027

MOTOR ANTENNA ASSEMBLY CHECK

1. Connect the circuit as indicated by the solid lines in the illustration.
2. Check that the motor antenna extends when the connection indicated by the broken line is made.
3. Check that the motor antenna retracts fully when the connection indicated by the broken line is removed.

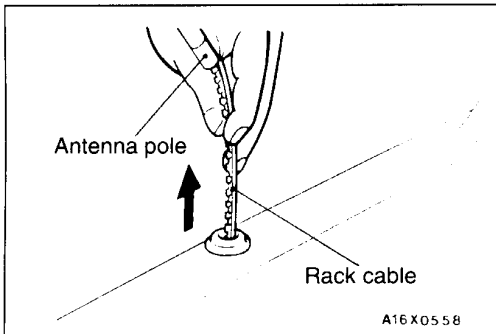
**ANTENNA POLE REPLACEMENT**

54400090032

- (1) Remove the ring nut.
- (2) After turning the ignition switch to ACC or ON, turn the radio switch to ON to raise the antenna pole, and remove it, together with the rack cable.

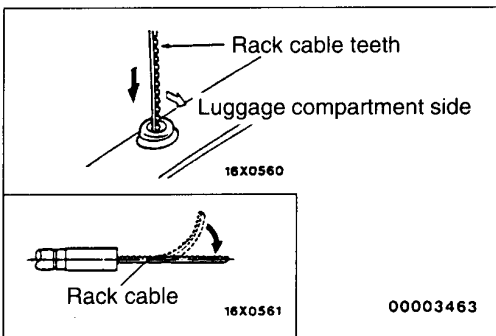

- (3) Draw out the antenna pole to the maximum extension.

NOTE

If there is a bend in the motor end of the rack cable, remove the bend.

- (4) Insert the rack cable into the motor assembly with the rack cable teeth facing the luggage compartment side.

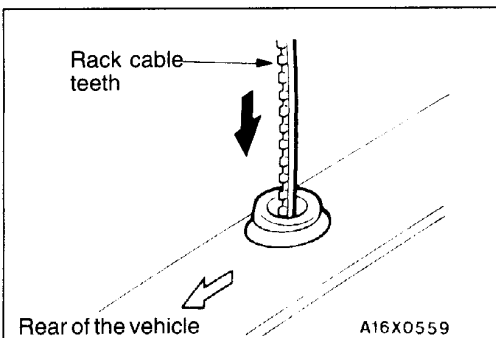

- (5) Turn the rack cable teeth towards the rear of the vehicle (right 90°) so that the rack cable meshes with the motor gear.
- (6) If the rack cable pulls out with no resistance when it is lightly pulled, then the cable is not meshed with the motor gear, so check that there are no bends in the end of the rack cable, and then repeat steps (4) and (5) above.
- (7) Set the antenna pole vertically and turn the radio switch OFF to wind up the rack cable. Insert the antenna to the motor antenna side to align it with the wound-up rack cable.
- (8) After tightening the ring nut, check the movement of the antenna by turning the radio switch ON and OFF.

REAR WINDOW DEFOGGER

54300180033

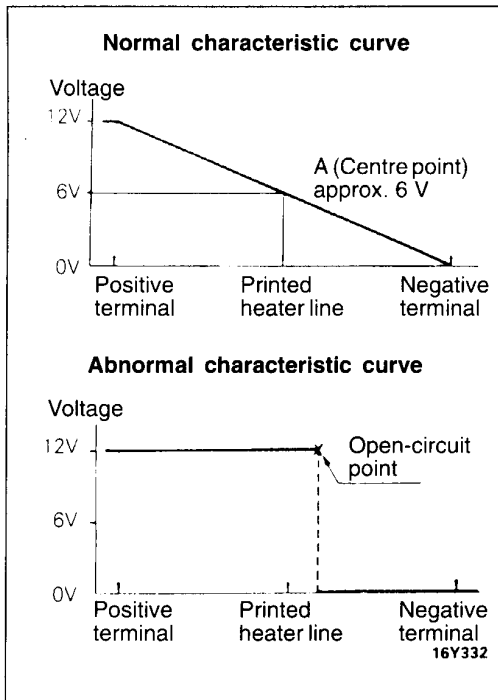

ON-VEHICLE SERVICE

PRINTED-HEATER LINE CHECK

- (1) Run engine at 2,000 r/min. Check heater element with battery at full.
- (2) Turn ON rear window defogger switch. Measure heater element voltage with circuit tester at rear window glass centre A.
Condition is good if it indicates about 6V.
- (3) If 12 V is indicated at A, there is a break in the negative terminals from A.
Move test bar slowly to negative terminal to detect where voltage changes suddenly (0V).
- (4) If 0 V is indicated at A, there is a break in the positive terminals from A. Defect where the voltage changes suddenly (12 V) in the same method described above.

REAR WINDOW DEFOGGER SWITCH

54300620030

REMOVAL AND INSTALLATION

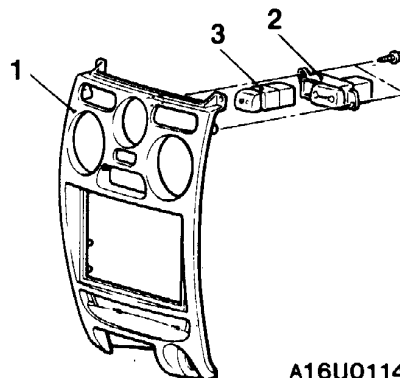

Removal steps

1. Center console panel
(Refer to GROUP 52A – Floor Console.)
2. Switch case
3. Rear window defogger switch

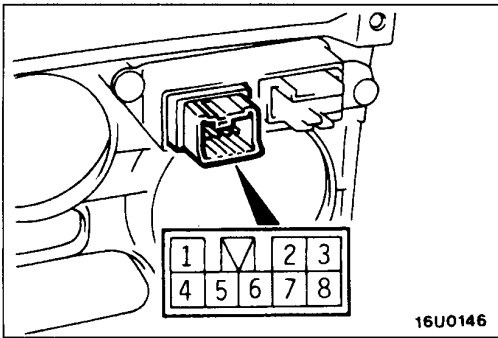

INSPECTION

DEFOGGER SWITCH CONTINUITY CHECK

Switch position	Terminal No.					
	1	2	3	4	5	6
OFF	○	ILL	○			
ON	○	ILL	○		IND	○

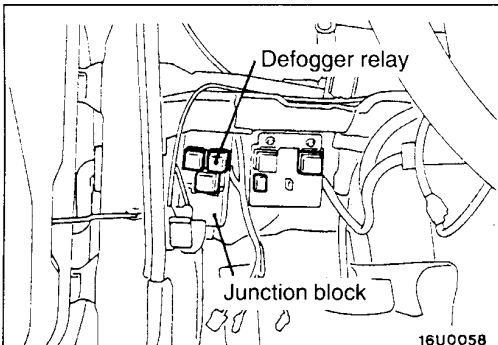

REAR WINDOW DEFOGGER RELAY CONTINUITY CHECK

Battery voltage	Terminal No.			
	1	2	3	5
Power is not supplied	○		○	
Power is supplied	+		-	○

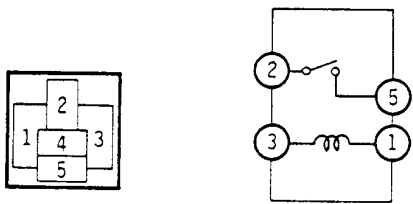

20Z0002
00003464