

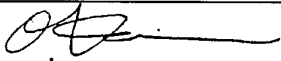

SERVICE BULLETIN

PUBLICATION GROUP, AFTER SALES SERVICE DEP.
MITSUBISHI MOTOR SALES EUROPE BV

SERVICE BULLETIN		No.: ESB-98E00-014	
		Date: 30-09-1999	<Model> <M/Y>
Subject: CHANGE IN TIGHTENING TORQUE FOR TENSIONER PULLEY MOUNTING NUT		(EC,EXP) CARISMA	96-10
Group: GENERAL			
CORRECTION		 O. Kai - E.V.P. & G.M. After Sales Service Dept.	

1. Description:

This Service Bulletin informs you of change in tightening torque for the mounting nut of the tensioner pulley of Volvo make.

2. Applicable Manuals:

Manual	Pub. No.	Language	Page(s)
'96 CARISMA Workshop Manual chassis	PWDE9502	(English)	11A-7, 55-29
	PWDS9503	(Spanish)	
	PWDF9504	(French)	
	PWDG9505	(German)	
	PWDD9506	(Dutch)	
	PWDW9507	(Swedish)	
	PWDI96E1	(Italian)	

4. Tighten the lock bolt.
Tighten torque: 23 Nm
5. Tighten the nut of the alternator pivot bolt
Tighten torque: 44 Nm
6. Tighten the adjusting bolt
Tighten torque: 6 Nm

POWER STEERING OIL PUMPO AND AIR CONDITIONER COMPRESSOR DRIVE BELT TENSION CHECK AND ADJUSTMENT

11100130035

1. Use belt tension gauge to check that the belt tension is at the standard value at a point half-way between the two pulleys (indicated by an arrow in the illustration). In addition, press this section with a force of 98 N and check that the amount of belt deflection at the standard value.

Standard value:

Items	When checked	When a used belt is installed	When a new belt is installed
Tension N	392-588	441-539	637-833
Deflection mm	10.0-12.0	10.0-11.0	7.0-9.0

2. If the tension or deflection is outside the standard value, adjust by the following procedure. **<Correct>**

- (1) Loosen tension pulley fixing bolt A. **Flange nut**
- (2) Adjust amount of belt deflection using adjusting bolt B. **<Correct>**
- (3) Tighten fixing bolt A. **Flange nut**

- (4) Check the belt deflection amount and tension, and readjust if necessary.

Caution

- Check after turning the crankshaft once or more clockwise (right up).

<Added>

Tighten torque:
25 Nm (for flange nut with flange O.D. of 19.5 mm)
38 Nm (for flange nut with flange O.D. of 21.8 mm)

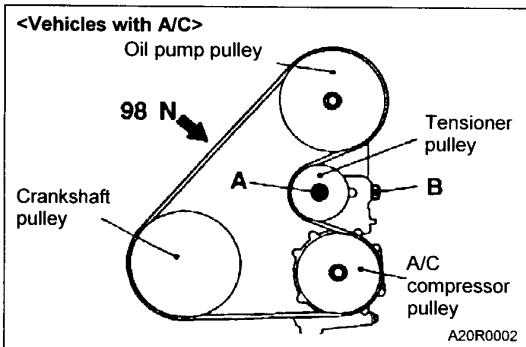
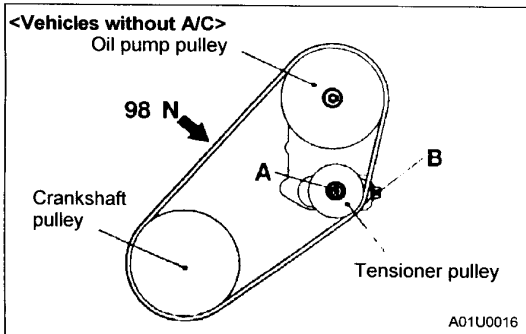

COMPRESSOR AND TENSION PULLEY

REMOVAL AND INSTALLATION

Pre removal Operation

- Discharging of Refrigerant (Refer to P.55-15)
- Under Cover, Removal (R.H. side)
- Power Steering Oil Pump Removal (Refer to GROUP 37A)

Post-installation Operation

- Charging of Refrigerant (Refer to P.55-11.)
- Under Cover Installation (R.H. side)
- Power Steering Oil Pump Removal (Refer to GROUP 37A)
- A/C Compressor Drive Belt Tension Adjustment (Refer to GROUP 11A- On-vehicle Service.)

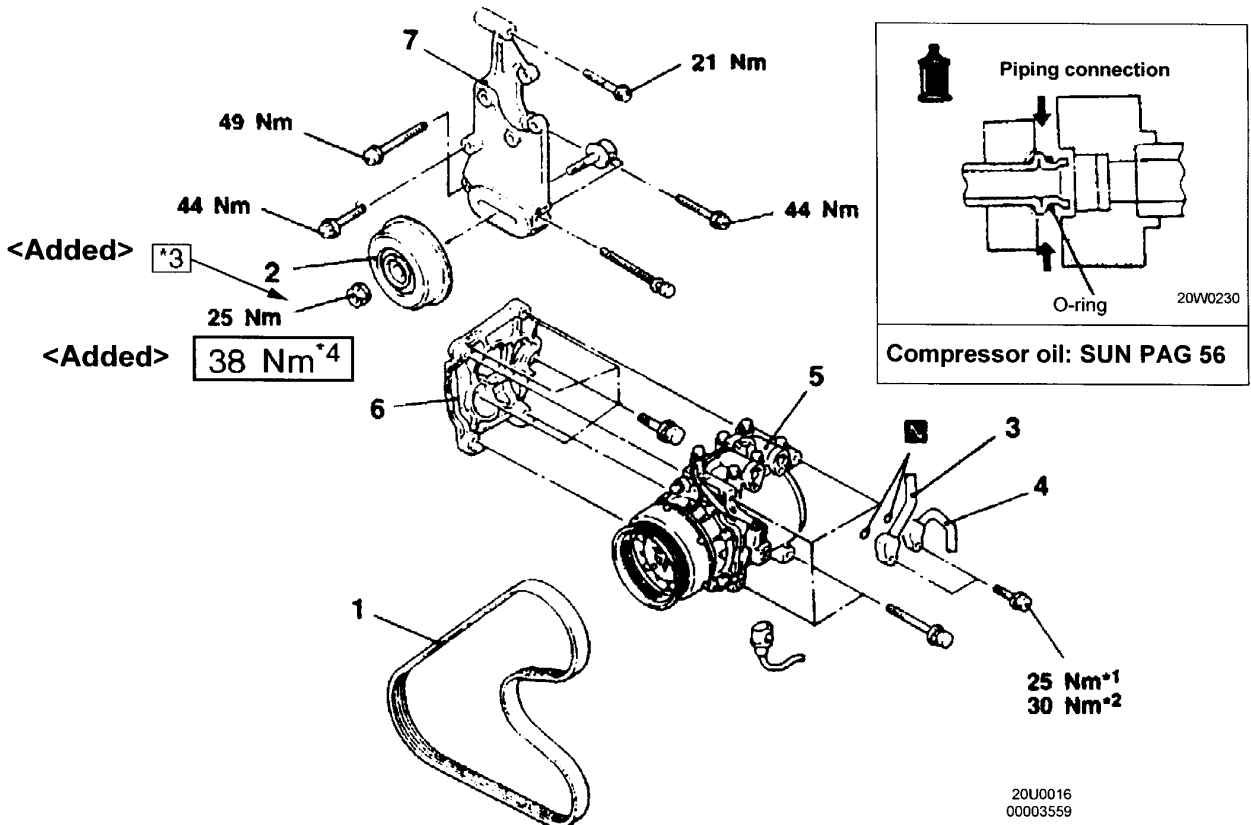

◀A▶

Removal steps

1. A/C compressor drive belt
2. Tension pulley
3. Suction hose connection
4. Discharge pipe connection
5. Compressor
6. Compressor bracket
7. Power steering oil pump bracket

◀B▶

◀B▶

◀C▶

◀A▶

NOTE

- (1) ¹: indicates flange bolt
 (2) ²: indicates flange bolt

(3) *3 : indicates flange nut with flange O.D. of 19.5 mm.
 (4) *4 : indicates flange nut with flange O.D. of 21.8 mm.

<Added>