

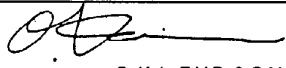

SERVICE BULLETIN

PUBLICATION GROUP, AFTER SALES SERVICE DEP.
MITSUBISHI MOTOR SALES EUROPE BV

SERVICE BULLETIN		No.: ESB-99E51-001	
		Date: 1999-12-15	<Model> (EC,EXP) CARISMA
Subject: ADDITION OF WASHER MOTOR REMOVAL		<M/Y> 96-10	
Group: EXTERIOR			
INFORMATION		 O. Kai - E.V.P. & G.M. After Sales Service Dept.	
1. Description: The washer motor removal procedure has been added.			
2. Applicable Manuals:			
Manual	Pub. No.	Language	Page(s)
'96 CARISMA Workshop Manual	PWDE9502	(English)	51-9, 10
	PWDS9503	(Spanish)	
	PWDF9504	(French)	
	PWDG9505	(German)	
	PWDD9506	(Dutch)	
	PWDW9507	(Swedish)	
	PWDI96E1	(Italian)	
3. Details:			

**WINDSHIELD WIPER AND WASHER
REMOVAL AND INSTALLATION**

51100760032

Pre-removal and Post-installation Operation

- Relay Box Removal and installation
<R.H. drive vehicles>

CAUTION: SRS

Before removal of air bag module and clock spring, refer to GROUP 52B - SRS Service Precautions and Air Bag Module and Clock Spring

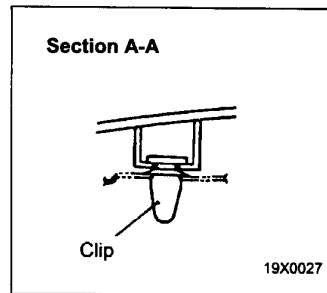
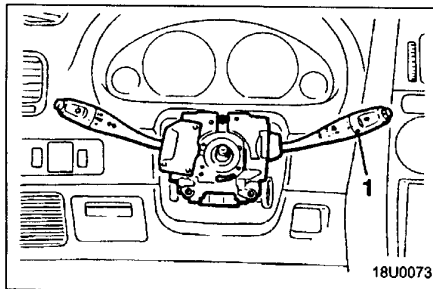
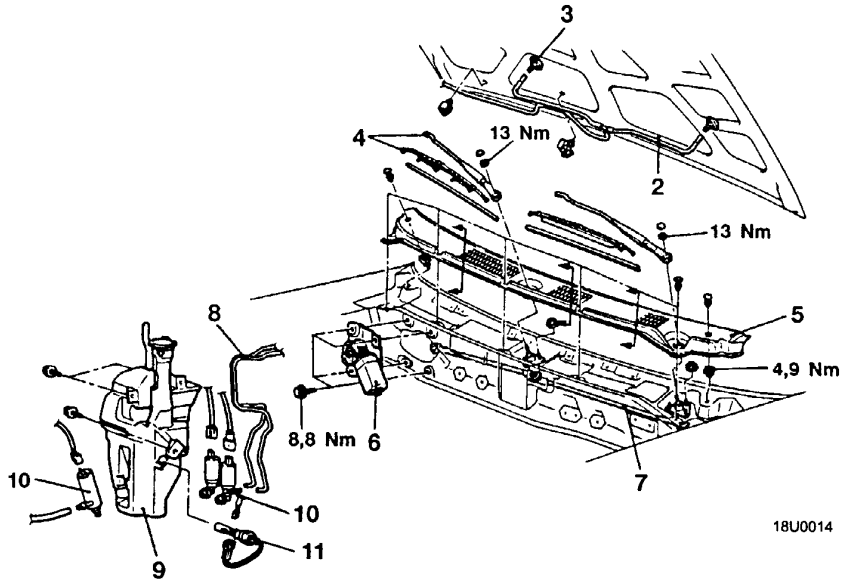

00003366

1. Column switch assembly (with built-in wiper and washer switch, and wiper relay) (Refer to GROUP 37A - Steering wheel and shaft.)
2. Washer hose
3. Washer nozzle

Washer tank removal steps

- Draining of washer fluid
- Front bumper (Refer to P.51-3.)
- 8. Washer hose
- 9. Washer tank
- 10. Washer motor
- 11. Washer fluid level switch

Wiper motor and linkage removal steps

4. Wiper arm and blade assembly
5. Front deck garnish
6. Wiper motor
7. Linkage

<Added>

Washer motor removal

10. Washer motor

◀A▶
▶A▶

◀B▶

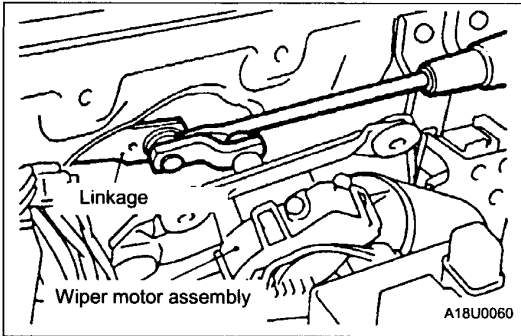

REMOVAL SERVICE POINT

◀A▶ WIPER MOTOR REMOVAL

Loosen the wiper motor assembly mounting bolts, and then remove the wiper motor assembly. Disconnect the linkage and the motor assembly, and then remove the linkage.

Caution

Because the installation angle of the crank arm and the motor has been set, do not remove them unless it is necessary to do so. If they must be removed, remove them only after marking their mounting positions.

<Added>

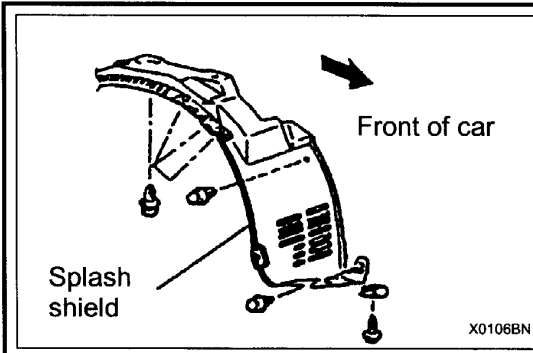

◀B▶ WASHER MOTOR REMOVAL

1. Remove the front under cover panel.
2. Partially remove the splash shield as shown.
3. Replace each washer motor.

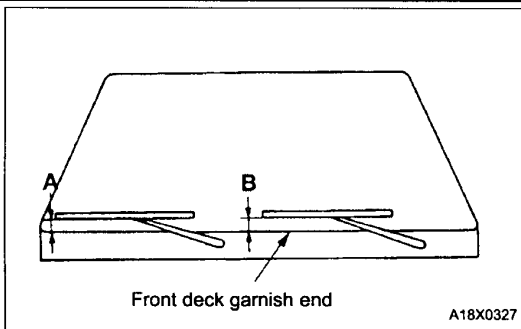

INSTALLATION SERVICE POINT

▶A◀ WIPER ARM AND BLADE ASSEMBLY INSTALLATION

- (1) The movements of the left and right wiper arms are different, so check the identification marks.
- (2) Install the wiper blade in the specified position (standard value) as shown in the illustration.

Standard value:

- Passenger's side (A): 20 ± 5 mm
- Driver's side (B): 25 ± 5 mm

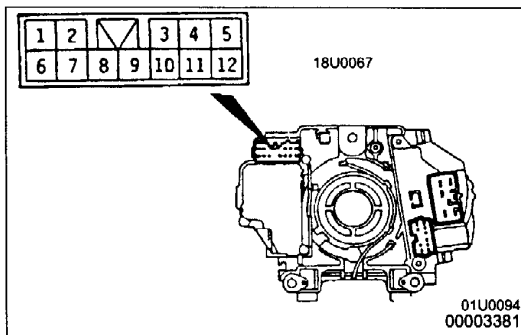

INSPECTION

COLUMN SWITCH CHECK

51100770035

Wiper and Washer Switch

Switch position		Terminal No.				
		6	7	8	9	10
Wiper switch	OFF		○	○		
	INT		○	○		
	1 (LO)			○		○
	2 (HI)				○	○
Washer switch	ON	○				○

Intermittent Wiper Relay (Intermittent Operation Inspection)

- (1) Connect the column switch connector.
- (2) Turn the ignition switch to ACC.