ENGINE <4G9>

CONTENTS

| | | | |
|-------------------------------------|----------|--|----------|
| GENERAL | 2 | Ignition Timing Check <GDI> | 3 |
| Outline of Changes | 2 | Idle Speed Check <GDI> | 4 |
| GENERAL INFORMATION | 2 | Compression Pressure Check <GDI> | 5 |
| SERVICE SPECIFICATIONS | 2 | Manifold Vacuum Check <GDI> | 6 |
| ON-VEHICLE SERVICE | 3 | TIMING BELT | 7 |

11A-2 ENGINE <4G9>-- General/General Information/Service Specifications

GENERAL

OUTLINE OF CHANGES

The service procedures have been established due to the following changes:

- The electronically-controlled throttle valve system has been introduced <GDI>.
- The timing belt cover has been changed <MPI, GDI>.

GENERAL INFORMATION

| Items | GDI |
|-------------------|------|
| Compression ratio | 12.0 |

SERVICE SPECIFICATIONS

<GDI>

| Items | | Standard value | Limit |
|---|-----|---|-------------|
| Basic ignition timing | | 5° BTDC ± 3° | - |
| Ignition timing | | Approx. 16° BTDC (Approx. 6° BTDC)*2 | - |
| Idle speed r/min | M/T | 600 ± 100*1 (750 ± 100)*2 | - |
| | A/T | 650 ± 100 (750 ± 100)*2 | - |
| Compression pressure kPa - r/min | | 1,720 - 300 | 1,462 - 300 |
| Compression pressure difference of all cylinder kPa | | - | Max. 100 |
| Intake manifold vacuum kPa | | - | Min. 34 |

NOTE

*1: Depends on the transmission oil temperature. For details, refer to P. 11A-3.

*2: Indicates the value when more than four minutes have passed since the engine was started.

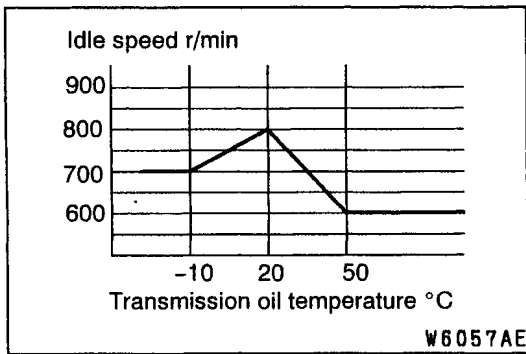

ON-VEHICLE SERVICE

IGNITION TIMING CHECK <GDI>

1. Before inspection, set the vehicle to the pre-inspection condition.

For vehicles with manual transmission, drive the vehicle for 15 minutes or more to warm the engine, and then carry out the checking while the transmission oil temperature is more than 50°C.

NOTE

The idle speed in vehicles with manual transmission varies as shown in the illustration in accordance with the transmission oil temperature.

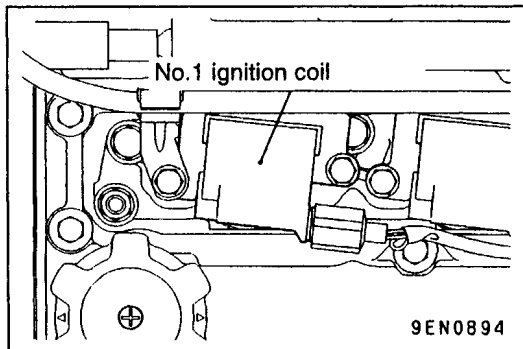

2. Turn the ignition switch to LOCK (OFF) position, and then connect the MUT-II to the diagnosis connector.
3. Set the timing light to the power supply line (terminal No.1) of the ignition coil No.1.

NOTE

The power supply line is looped and also longer than the other ones.

4. Start the engine and let it run at idle.
5. Use the MUT-II to measure engine idle speed and check that it is within the standard value.

Standard value:

| Items | Idle speed r/min |
|-------|------------------------|
| M/T | 600 ± 100 (750 ± 100)* |
| A/T | 650 ± 100 (750 ± 100)* |

NOTE

*: Indicates the values when more than 4 minutes have passed since the idling condition was started.

6. Select No.17 of the MUT-II Actuator test.

NOTE

At this time, the engine speed will become approximately 750 r/min.

7. Check that basic ignition timing is within the standard value.

Standard value: 5° BTDC ± 3°

8. If the basic ignition timing is outside the standard value, inspect the GDI system while referring to GROUP 13J - Troubleshooting.

9. Press the MUT-II clear key (Select a forced driving cancel mode) to release the Actuator test.

Caution

If the test is not cancelled, a forced driving will continue for 27 minutes. Driving under this condition may damage the engine.

10. Check that ignition timing is at the standard value.

Standard value: approx. 16° BTDC

NOTE

(1) The ignition timing will become approximately 6° BTDC after more than 4 minutes have passed since the basic ignition timing set mode was released.

(2) The ignition timing may fluctuate within $\pm 7^\circ$ BTDC. This is normal.

11. Remove the timing light.
12. Turn the ignition switch to LOCK (OFF) position, and then remove the MUT-II.

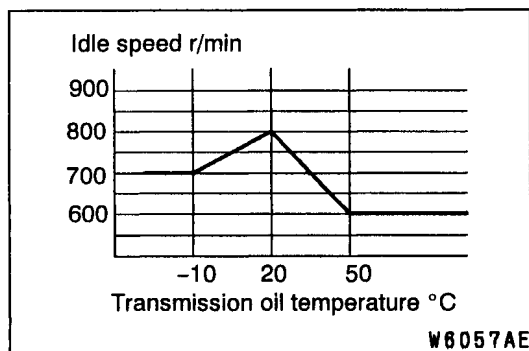
**IDLE SPEED CHECK <GDI>**

1. Before inspection, set the vehicle to the pre-inspection condition.

For vehicles with manual transmission, drive the vehicle for 15 minutes or more to warm the engine, and then carry out the checking while the transmission oil temperature is more than 50°C.

NOTE

The idle speed in vehicles with manual transmission varies as shown in the illustration in accordance with the transmission oil temperature.

2. Turn the ignition switch to LOCK (OFF) position, and then connect the MUT-II to the diagnosis connector.
3. Check the basic ignition timing.

NOTE

Refer to P.11A-3 concerning the check procedure of the basic ignition timing.

Standard value: 5° BTDC \pm 3°

4. Run the engine at idle for 2 minutes.

5. Check the idle speed. Select item No. 22 and take a reading of the idle speed.

Standard value:

| Items | Idle speed r/min |
|-------|------------------------|
| M/T | 600 ± 100 (750 ± 100)* |
| A/T | 650 ± 100 (750 ± 100)* |

NOTE

- (1) *: Indicates the values when more than 4 minutes have passed since the idling condition was started.
 - (2) The idle speed is automatically controlled by the idle speed control system.
6. If the idle speed is outside the standard value, inspect the GDI components by referring to GROUP 13J - Troubleshooting.

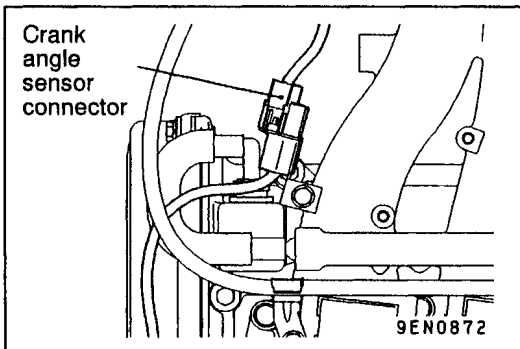
**COMPRESSION PRESSURE CHECK <GDI>**

1. Before inspection, check that the engine oil, starter and battery are normal. In addition, set the vehicle to the pre-inspection condition.
2. Remove all of the ignition coils and spark plugs.
3. Disconnect the crank angle sensor connector.

NOTE

Doing this will prevent the engine-ECU from carrying out ignition and fuel injection.

4. Cover the spark plug hole with a shop towel etc., and after the engine has been cranked, check that no foreign material is adhering to the shop towel.

Caution

- (1) Keep away from the spark plug hole when cranking.
- (2) If compression is measured with water, oil, fuel, etc., that has come from cracks inside the cylinder, these materials will become heated and will gush out from the spark plug hole, which is dangerous.

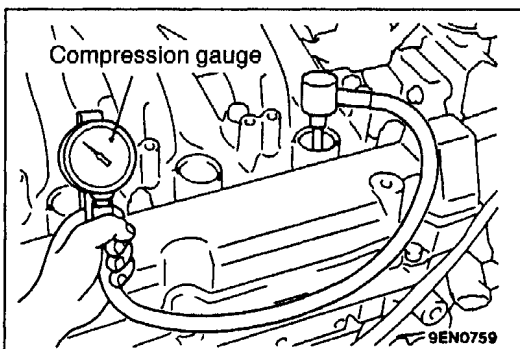

5. Set compression gauge to one of the spark plug holes.
6. Crank the engine with the throttle valve fully open and measure the compression pressure.

Standard value (at engine speed of 300 r/min):
1,720 kPa

Limit (at engine speed of 300 r/min):
Min. 1,462 kPa

7. Measure the compression pressure for all the cylinders, and check that the pressure differences of the cylinders are below the limit.

Limit: Max. 100 kPa

8. If there is a cylinder with compression or a compression difference that is outside the limit, pour a small amount of engine oil through the spark plug hole, and repeat the operations in steps 6 and 7.

(1) If the compression increases after oil is added, the cause of the malfunction is a worn or damaged piston ring and/or cylinder inner surface.

(2) If the compression does not rise after oil is added, the cause is a burnt or defective valve seat, or pressure is leaking from the gasket.

9. Connect the crank angle sensor connector.
10. Install the spark plugs and ignition coils.
11. Use the MUT-II to erase the diagnosis codes.

NOTE

This will erase the diagnosis code resulting from the crank angle sensor connector being disconnected.

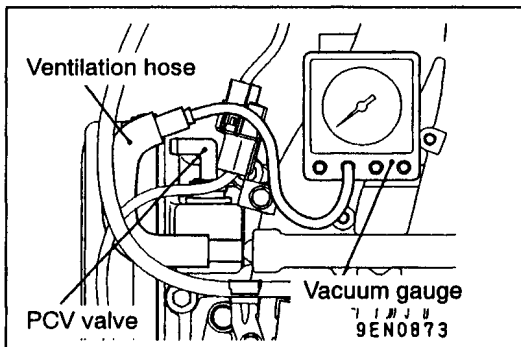

MANIFOLD VACUUM CHECK <GDI>

1. Before inspection, set the vehicle to the pre-inspection condition.
2. Disconnect the ventilation hose from the positive crankcase ventilation (PCV) valve, and then connect a vacuum gauge to the ventilation hose.
3. Check the intake manifold vacuum while the engine is idling.

Limit: Min. 34 kPa

TIMING BELT**REMOVAL AND INSTALLATION****Pre-removal and Post-Installation Operation**

- Under Cover Removal and Installation
- Crankshaft Pulley Removal and Installation
- Drive Belt Tension Adjustment

<MPI>

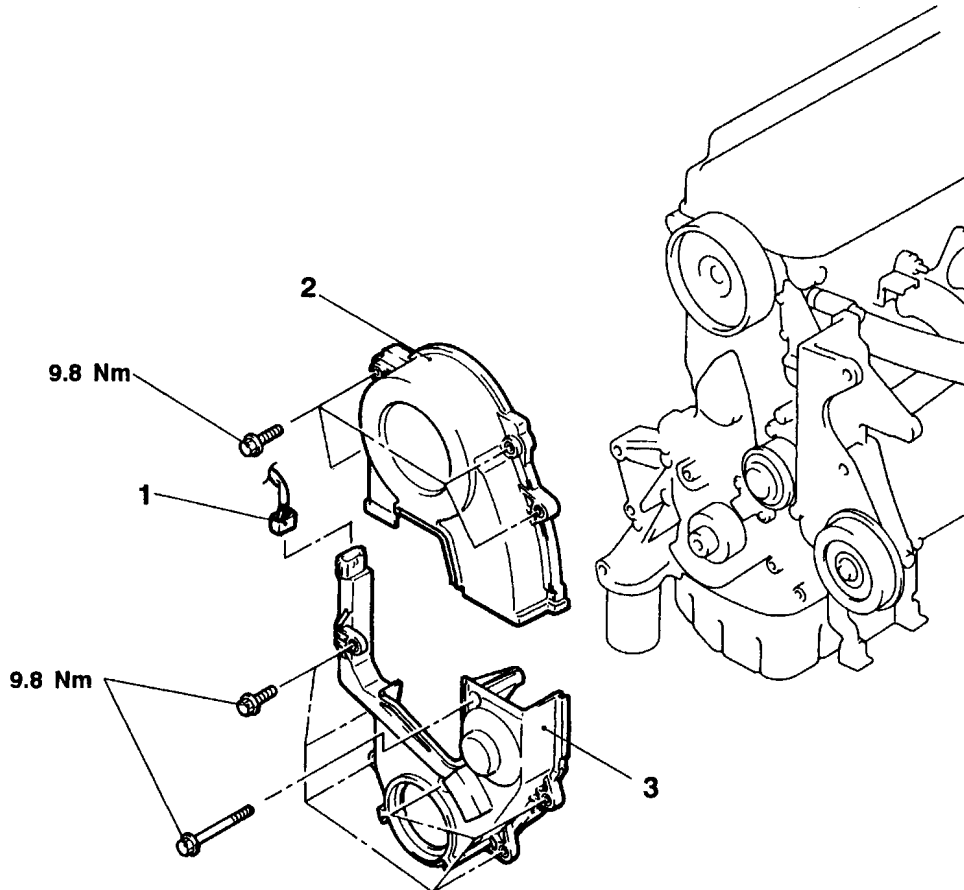

AX0002BN

Removal steps

1. Crank angle sensor connector
2. Timing belt front upper cover
3. Timing belt front lower cover



<GDI>

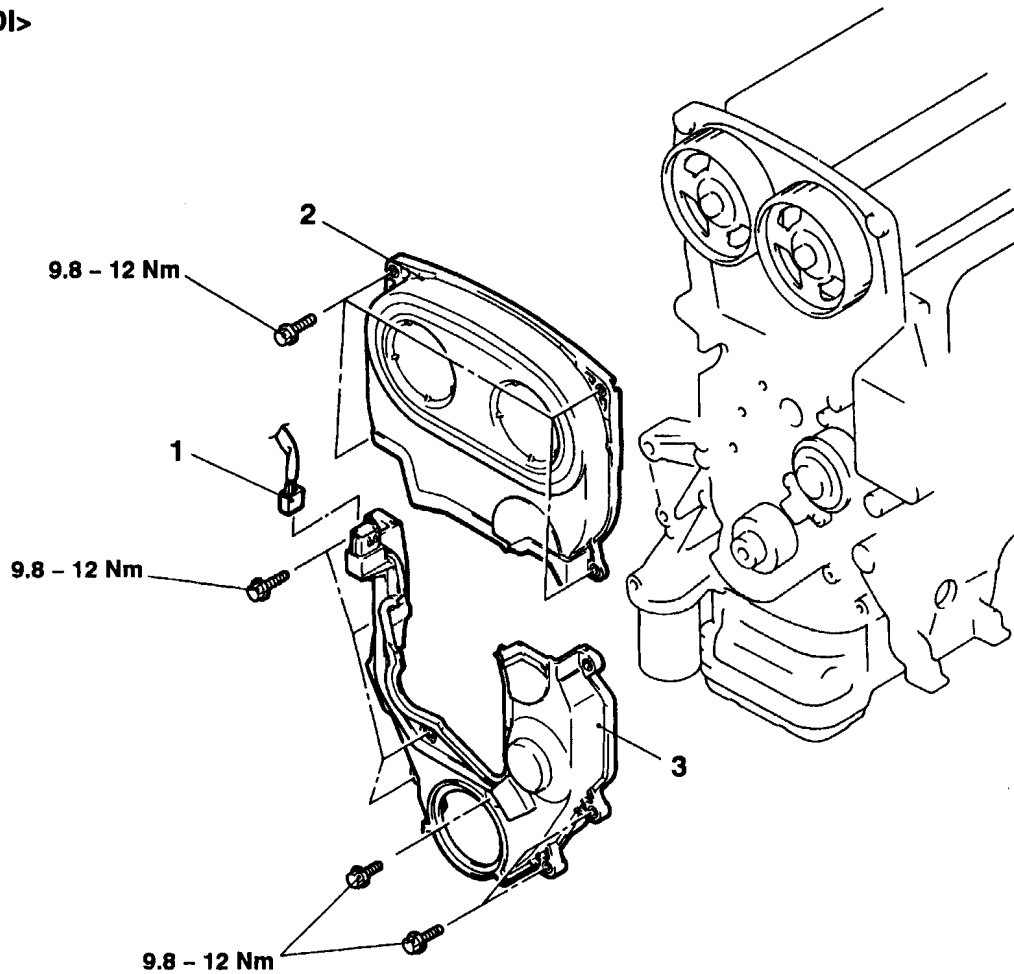

AX0001BN

Removal steps

1. Crank angle sensor connector
2. Timing belt front upper cover
- ▶A◀ 3. Timing belt front lower cover

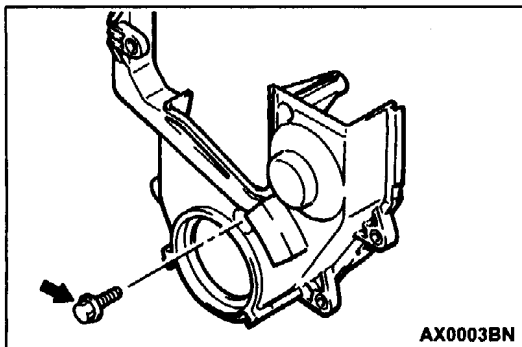
**INSTALLATION SERVICE POINT****▶A◀ TIMING BELT FRONT LOWER COVER INSTALLATION**

1. Install the shown bolt first.
2. Install the remaining bolts, and then tighten the all bolts to the specified torque.

Tightening torque:

- <MPI> 9.8 Nm
- <GDI> 9.8 - 12 Nm