

# AUTOMATIC TRANSMISSION

## CONTENTS

<b>GENERAL</b> .....	<b>2</b>	<b>ON-VEHICLE SERVICE</b> .....	<b>23</b>
Outline of Changes .....	2	A/T Control Component Location .....	23
<b>GENERAL INFORMATION</b> .....	<b>2</b>	Selector Lever Operation Check .....	23
<b>TROUBLESHOOTING</b> .....	<b>2</b>	<b>TRANSMISSION CONTROL*</b> .....	<b>24</b>

### WARNING REGARDING SERVICING OF SUPPLEMENTAL RESTRAINT SYSTEM (SRS) EQUIPPED VEHICLES

#### WARNING!

- (1) Improper service or maintenance of any component of the SRS, or any SRS-related component, can lead to personal injury or death to service personnel (from inadvertent firing of the air bag) or to driver and passenger (from rendering the SRS inoperative).
- (2) Service or maintenance of any SRS component or SRS-related component must be performed only at an authorized MITSUBISHI dealer.
- (3) MITSUBISHI dealer personnel must thoroughly review this manual, and especially its GROUP 52B - Supplemental Restraint System (SRS) before beginning any service or maintenance of any component of the SRS or any SRS-related component.

#### NOTE

The SRS includes the following components: SRS-ECU, SRS warning lamp, air bag module, clock spring, side impact sensors and interconnecting wiring. Other SRS-related components (that may have to be removed/installed in connection with SRS service or maintenance) are indicated in the table of contents by an asterisk (\*).

## GENERAL

### OUTLINE OF CHANGES

The following service procedures for items which are different from before have been established to correspond to the following changes.

- The A/T-ECU idle position switch terminal has been discontinued.
- The auto-cruise control terminal has been discontinued from the engine-A/T-ECU <4G9-MPI>.
- The shift pattern has been changed.
- The final reduction ratio has been changed.
- The selector lever assembly has been changed.

### GENERAL INFORMATION

Transmission model	F4A41	F4A42
Engine model	4G9-MPI	4G9-GDI
Final reduction ratio	4.407	4.042

## TROUBLESHOOTING

### SHIFT PATTERN

<MPI>

#### UPSHIFT PATTERN

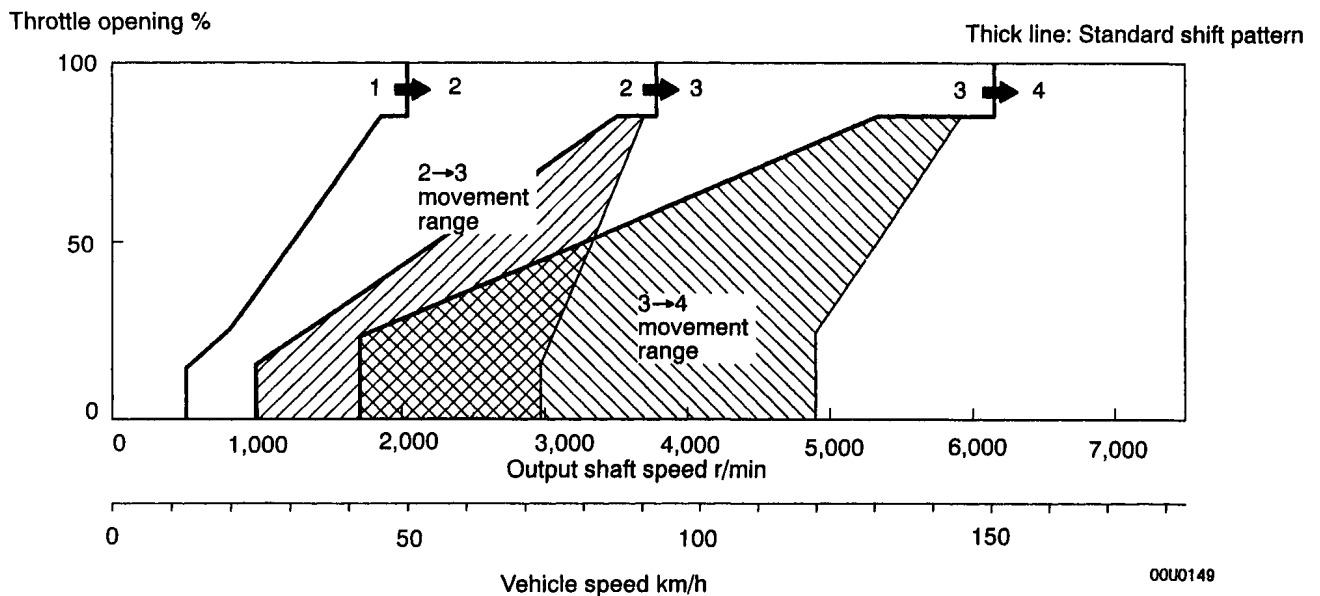

**DOWNSHIFT PATTERN**

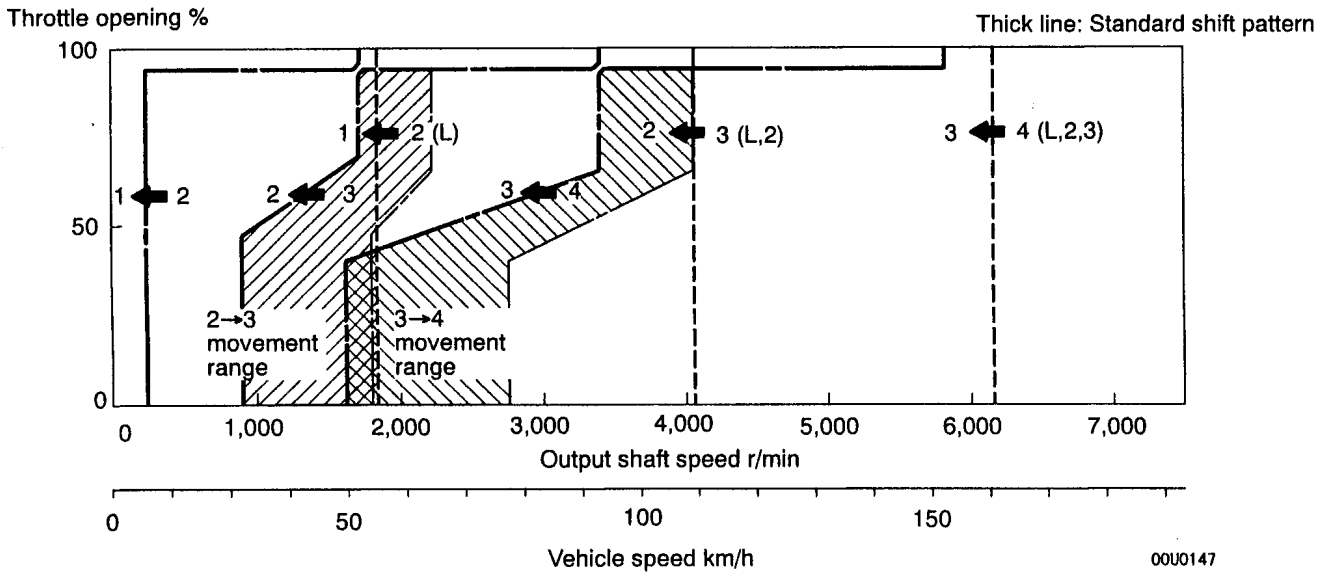

**HOLD MODE PATTERN**

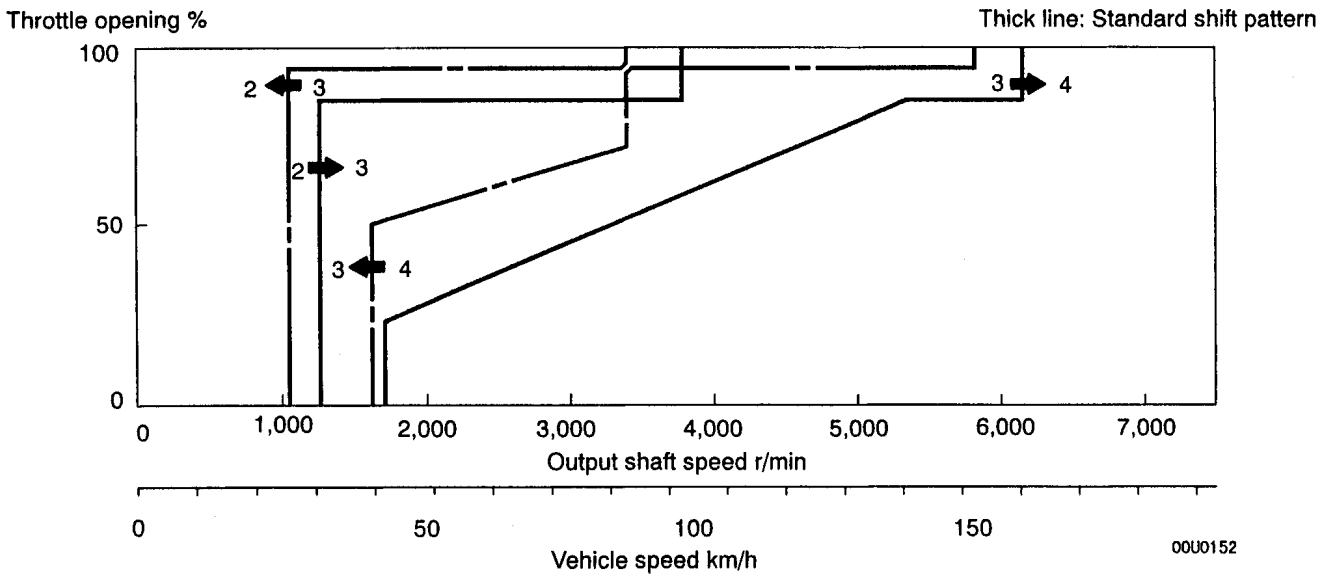

<GDI>

UPSHIFT PATTERN

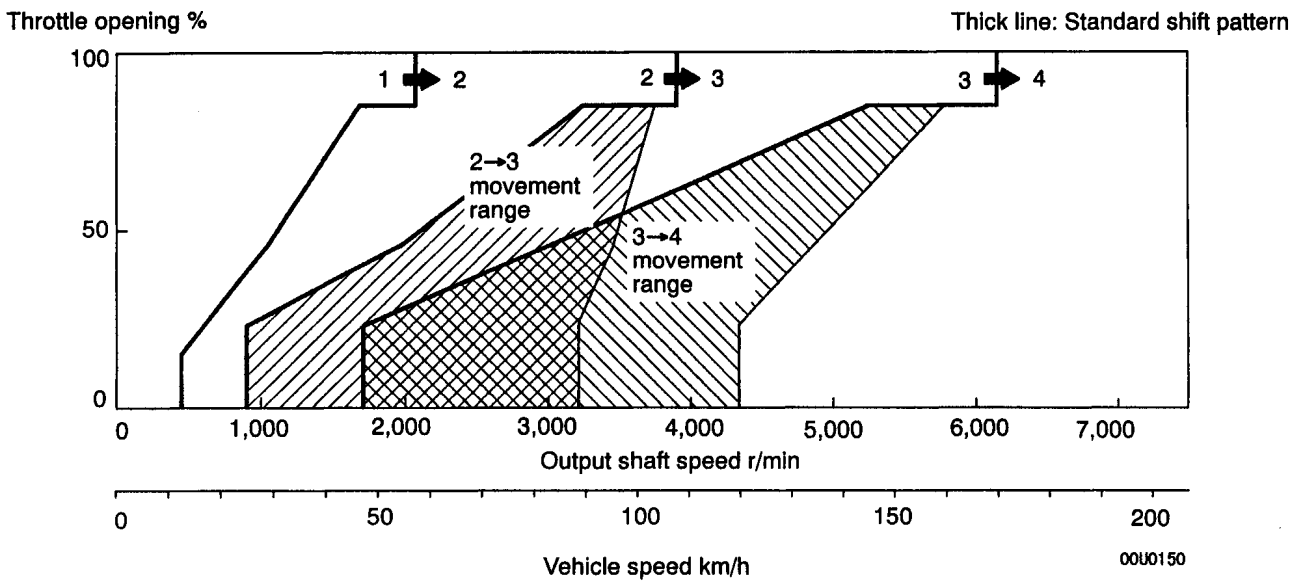

DOWNSHIFT PATTERN

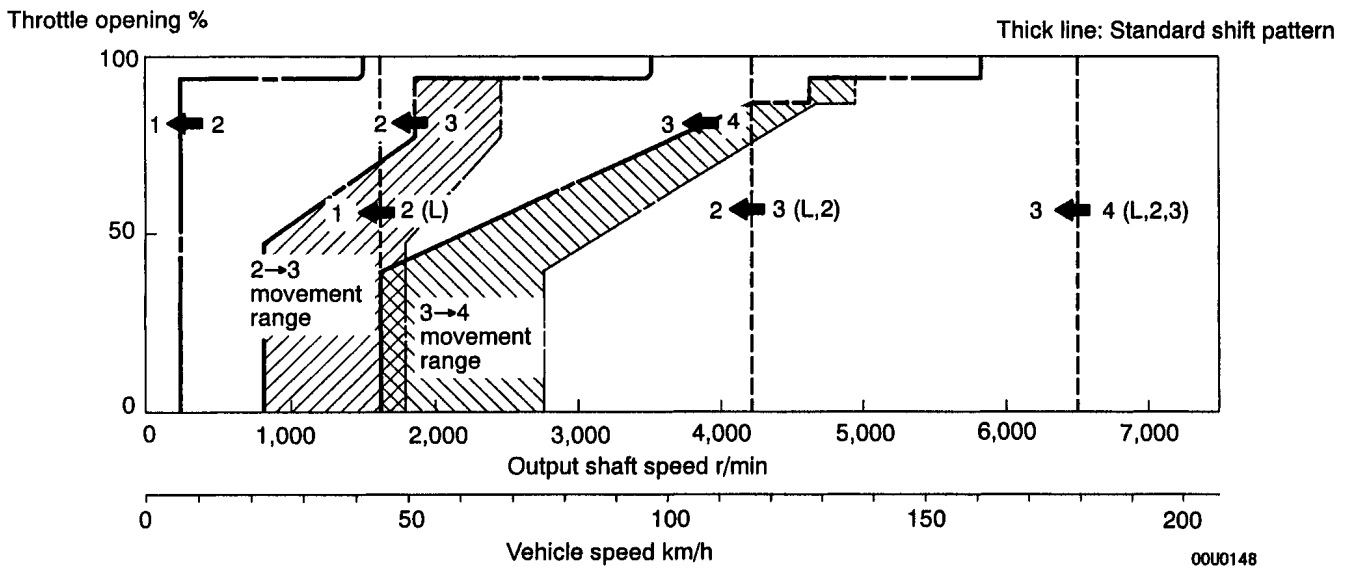

**HOLD MODE PATTERN**

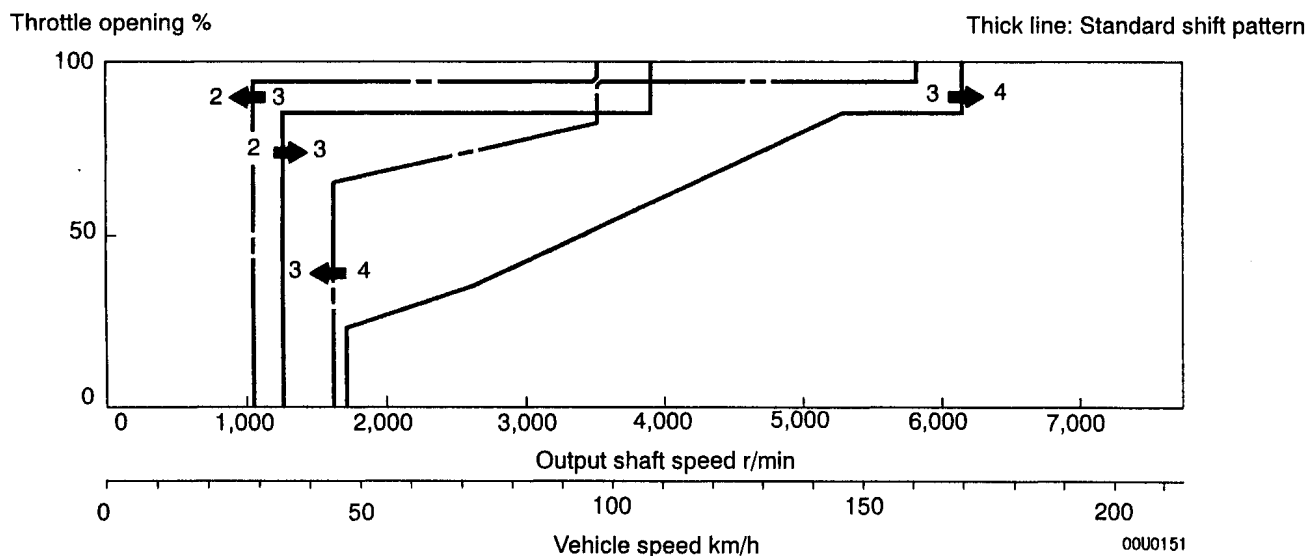

**INSPECTION CHART FOR DIAGNOSIS CODE**

Code	Diagnosis item	Reference page
11	Throttle position sensor system <MPI> Accelerator pedal position sensor system <GDI>	Short circuit
12		Open circuit
14		Sensor maladjustment
15	Oil temperature sensor system	Open circuit
21	Crank angle sensor system	Open circuit
22	Input shaft speed sensor system	Short circuit/open circuit
23	Output shaft speed sensor system	Short circuit/open circuit
25	Wide open throttle switch system	Short circuit
26	Stop lamp switch system	Short circuit/open circuit
31	Low and reverse solenoid valve system	Short circuit/open circuit
32	Underdrive solenoid valve system	Short circuit/open circuit
33	Second solenoid valve system	Short circuit/open circuit
34	Overdrive solenoid valve system	Short circuit/open circuit
36	Damper control clutch solenoid valve system	Short circuit/open circuit
41	1st gear ratio does not meet the specification	23-10
42	2st gear ratio does not meet the specification	23-10
43	3rd gear ratio does not meet the specification	23-10
44	4th gear ratio does not meet the specification	23-10
46	Reverse gear ratio does not meet the specification	23-10
51	Abnormal communication with engine-ECU	23-12

Code	Diagnosis item	Reference page
52	Damper control clutch solenoid valve system	23-10
54	A/T Control relay system	23-12
56	N range lamp system	23-13

**INSPECTION PROCEDURES FOR DIAGNOSIS CODES**

Code No. 11, 12, 14 Throttle position sensor system <MPI>, accelerator pedal position sensor <GDI>	Probable cause
<p>If the TPS or APS output voltage is 4.8 V or higher when the engine is idling, the output is judged to be too high and diagnosis code No. 11 is output. If the TPS or APS output voltage is 0.2 V or lower at times other than when the engine is idling, the output is judged to be too low and diagnosis code No. 12 is output. If the TPS or APS output voltage is 0.2 V or lower or if it is 1.2 V or higher when the engine is idling, the TPS or APS adjustment is judged to be incorrect and diagnosis code No. 14 is output.</p>	<ul style="list-style-type: none"> <li>● Malfunction of the throttle position sensor &lt;MPI&gt;</li> <li>● Malfunction of the accelerator pedal position sensor &lt;GDI&gt;</li> <li>● Malfunction of connector</li> <li>● Malfunction of the engine-A/T-ECU &lt;MPI&gt;</li> <li>● Malfunction of the A/T-ECU &lt;GDI&gt;</li> </ul>

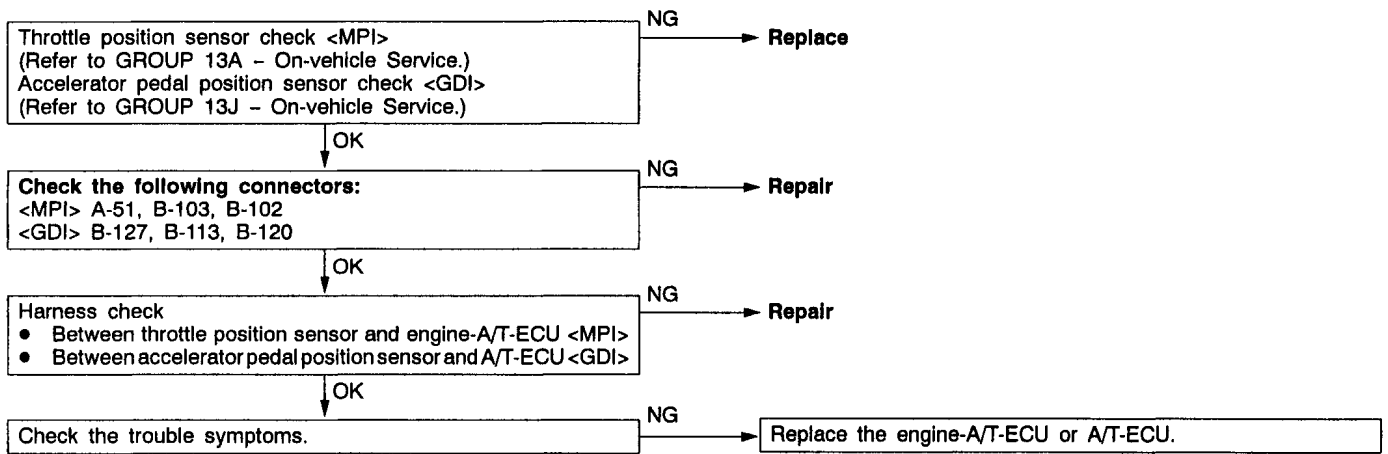

Code No. 15 Oil temperature sensor system	Probable cause
<p>If the oil temperature sensor output voltage is 2.6 V or more even after driving for 10 minutes or more (if the oil temperature does not increase), it is judged that there is an open circuit in the oil temperature sensor and diagnosis code No. 15 is output.</p>	<ul style="list-style-type: none"> <li>● Malfunction of the oil temperature sensor</li> <li>● Malfunction of connector</li> <li>● Malfunction of the engine-A/T-ECU &lt;MPI&gt;</li> <li>● Malfunction of the A/T-ECU &lt;GDI&gt;</li> </ul>

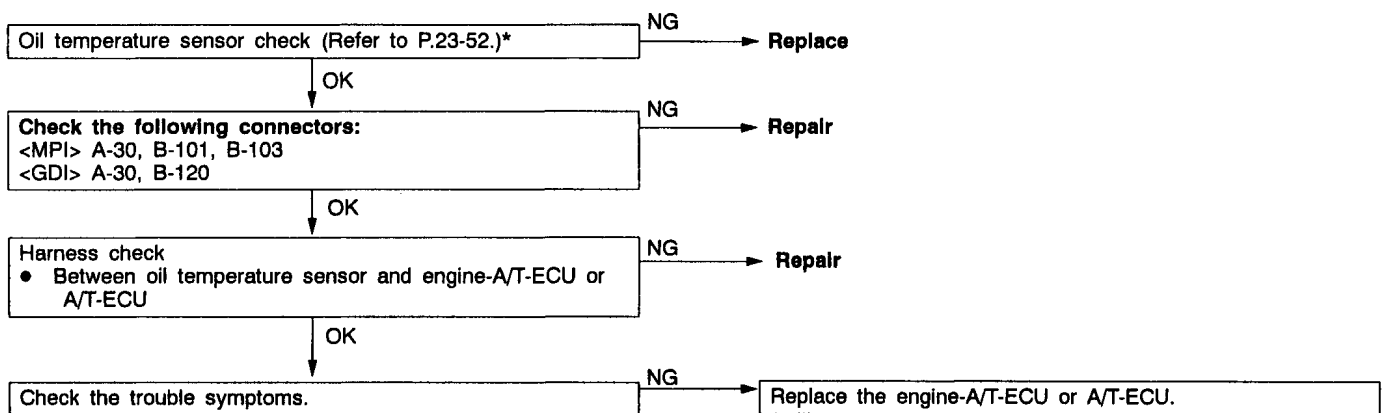

**NOTE**

\*: Refer to '96 CARISMA Workshop Manual (Pub No. PWDE9502).

Code No. 21 Crank angle sensor system	Probable cause
If no output pulse is detected from the crank angle sensor for 5 seconds or more while driving at 25 km/h or more, it is judged that there is an open circuit in the crank angle sensor and diagnosis code No. 21 is output.	<ul style="list-style-type: none"> <li>● Malfunction of the crank angle sensor</li> <li>● Malfunction of connector</li> <li>● Malfunction of the engine-A/T-ECU &lt;MPI&gt;</li> <li>● Malfunction of the A/T-ECU &lt;GDI&gt;</li> </ul>

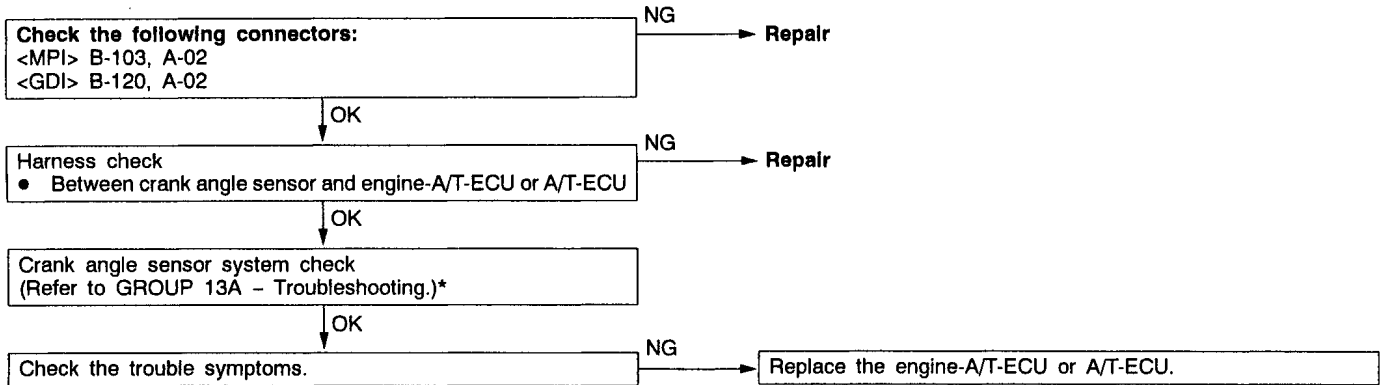

Code No. 22 Input shaft speed sensor system	Probable cause
If no output pulse is detected from the input shaft speed sensor for 1 second or more while driving in 3rd or 4th gear at a speed of 30 km/h or more, there is judged to be an open circuit or short-circuit in the input shaft speed sensor and diagnosis code No. 22 is output. If diagnosis code No. 22 is output four times, the transmission is locked into 3rd gear (D range) or 2nd gear as a fail-safe measure, and the N range lamp flashes at a frequency of 1 Hz.	<ul style="list-style-type: none"> <li>● Malfunction of the input shaft speed sensor</li> <li>● Malfunction of the underdrive clutch retainer</li> <li>● Malfunction of connector</li> <li>● Malfunction of the engine-A/T-ECU &lt;MPI&gt;</li> <li>● Malfunction of the A/T-ECU &lt;GDI&gt;</li> </ul>

★: Refer to the Transmission Workshop Manual.

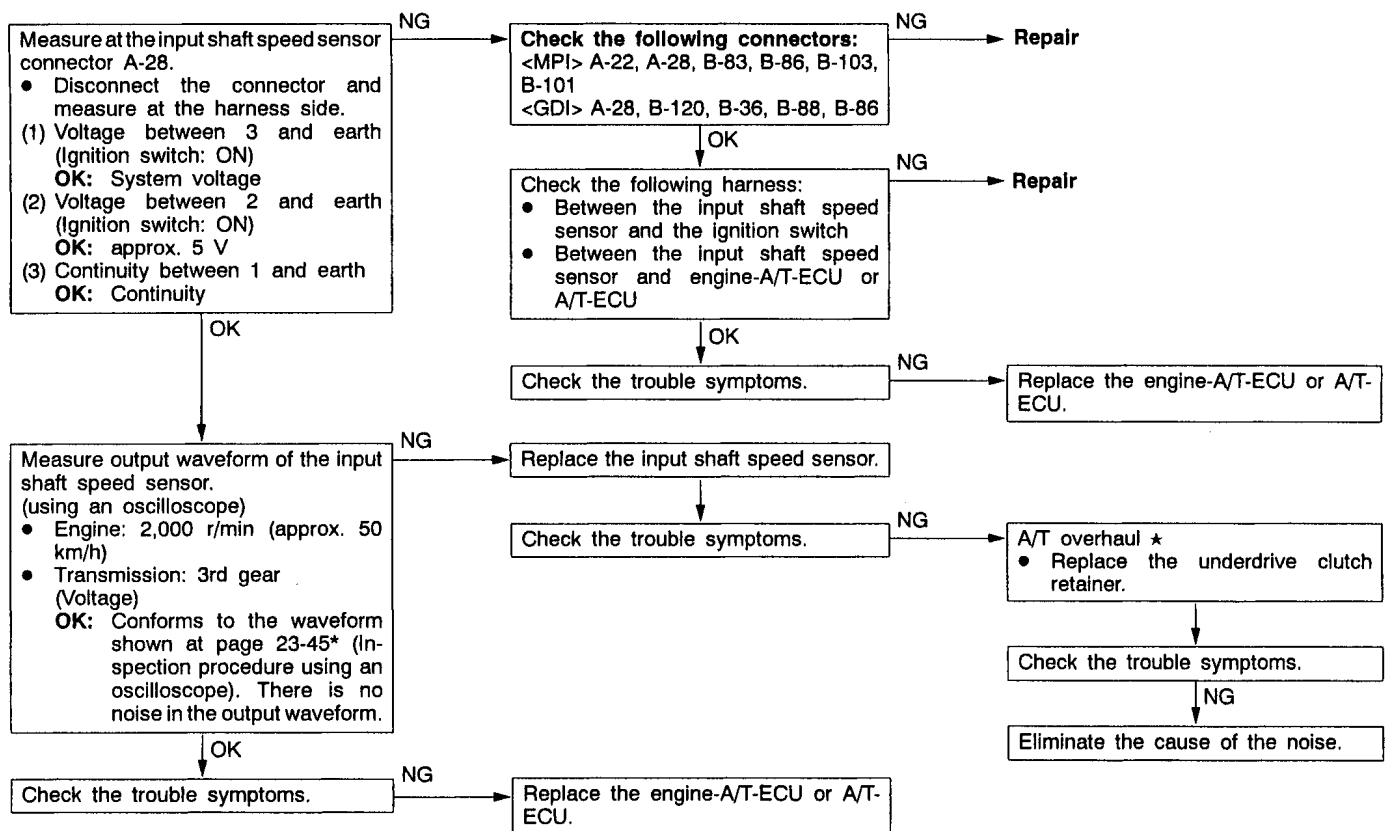

**NOTE**

\*: Refer to '96 CARISMA Workshop Manual (Pub No. PWDE9502).

Code No. 23 Output shaft speed sensor system	Probable cause
<p>If the output from the output shaft speed sensor is continuously 50% lower than the vehicle speed for 1 second or more while driving in 3rd or 4th gear at a speed of 30 km/h or more, there is judged to be an open circuit or short-circuit in the output shaft speed sensor and diagnosis code No. 23 is output.</p> <p>If diagnosis code No. 23 is output four times, the transmission is locked into 3rd gear (D range) or 2nd gear as a fail-safe measure, and the N range lamp flashes at a frequency of 1 Hz.</p>	<ul style="list-style-type: none"> <li>● Malfunction of the output shaft speed sensor</li> <li>● Malfunction of the transfer drive gear or driven gear</li> <li>● Malfunction of connector</li> <li>● Malfunction of the engine-A/T-ECU &lt;MPI&gt;</li> <li>● Malfunction of the A/T-ECU &lt;GDI&gt;</li> </ul>

★: Refer to the Transmission Workshop Manual.

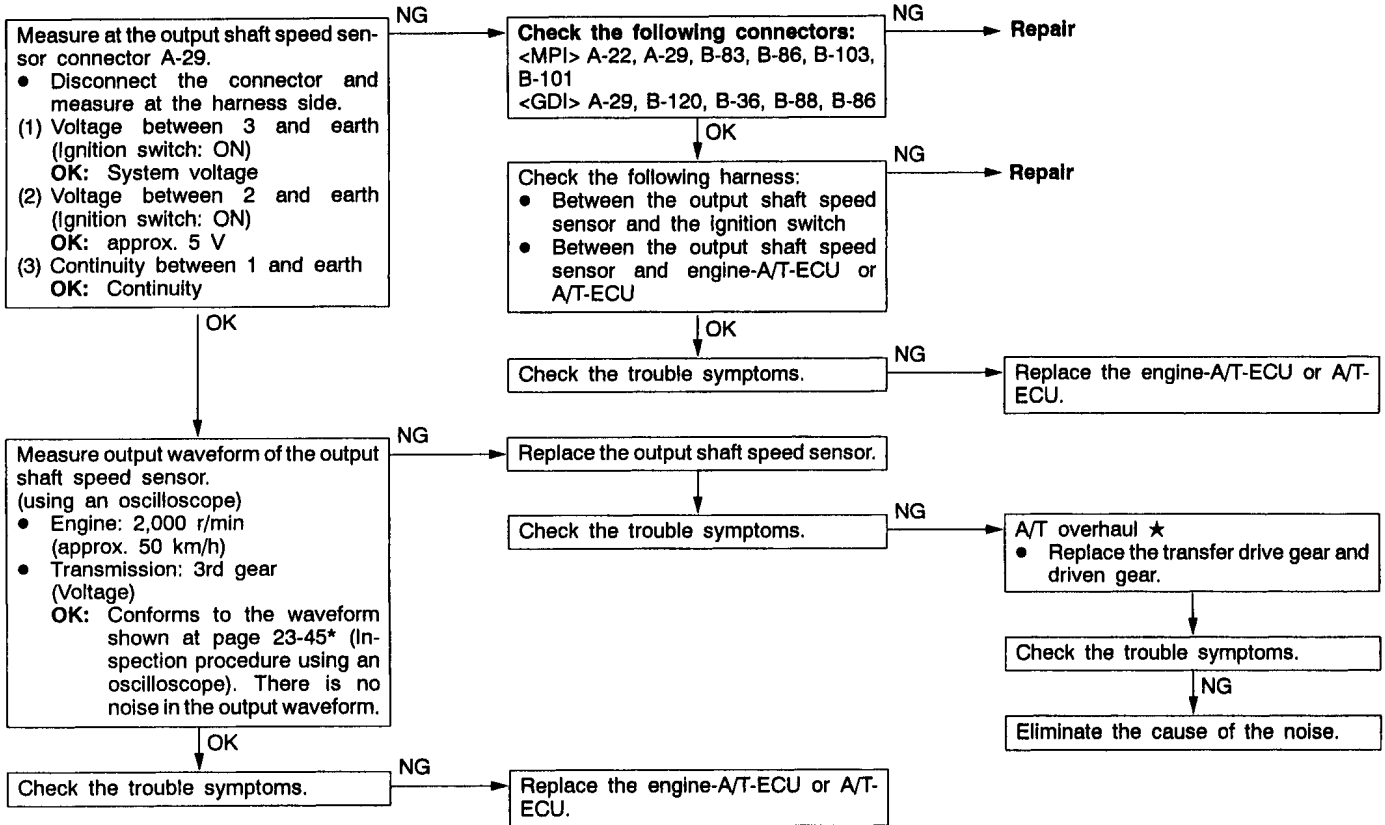

Code No. 25 Wide open throttle switch system	Probable cause
<p>If the wide open throttle switch is on for 1 second or more with the throttle valve opening angle at 70% or less, it is judged that there is a short circuit in the wide open throttle switch and diagnosis code No. 25 is output.</p>	<ul style="list-style-type: none"> <li>● Malfunction of the wide open throttle switch</li> <li>● Malfunction of connector</li> <li>● Malfunction of the engine-A/T-ECU &lt;MPI&gt;</li> <li>● Malfunction of the A/T-ECU &lt;GDI&gt;</li> </ul>

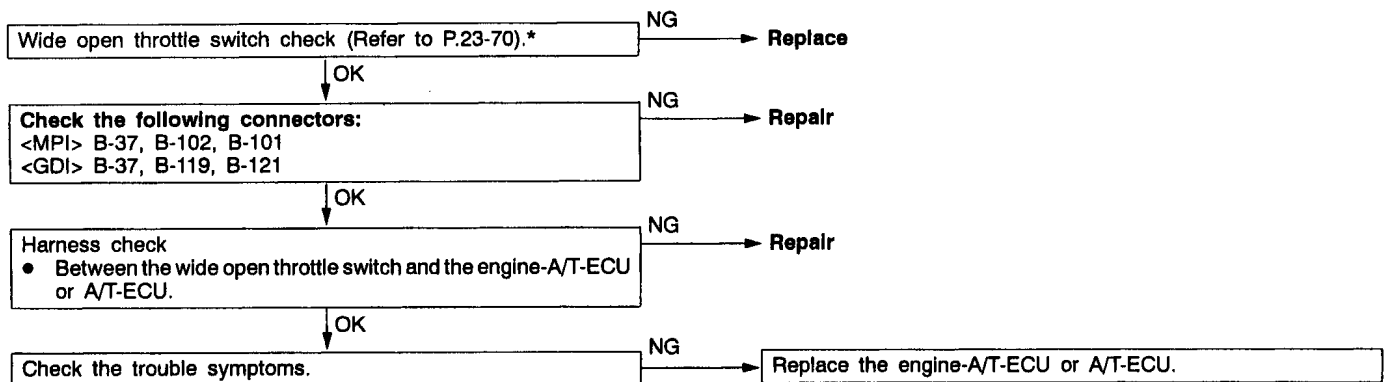

NOTE

\*: Refer to '96 CARISMA Workshop Manual (Pub No. PWDE9502).



<b>Code No. 26 Stop lamp switch system</b>	<b>Probable cause</b>
If the stop lamp switch is on for 5 minutes or more while driving, it is judged that there is a short circuit in the stop lamp switch and diagnosis code No. 26 is output.	<ul style="list-style-type: none"> <li>● Malfunction of the stop lamp switch</li> <li>● Malfunction of connector</li> <li>● Malfunction of the engine-A/T-ECU &lt;MPI&gt;</li> <li>● Malfunction of the A/T-ECU &lt;GDI&gt;</li> </ul>

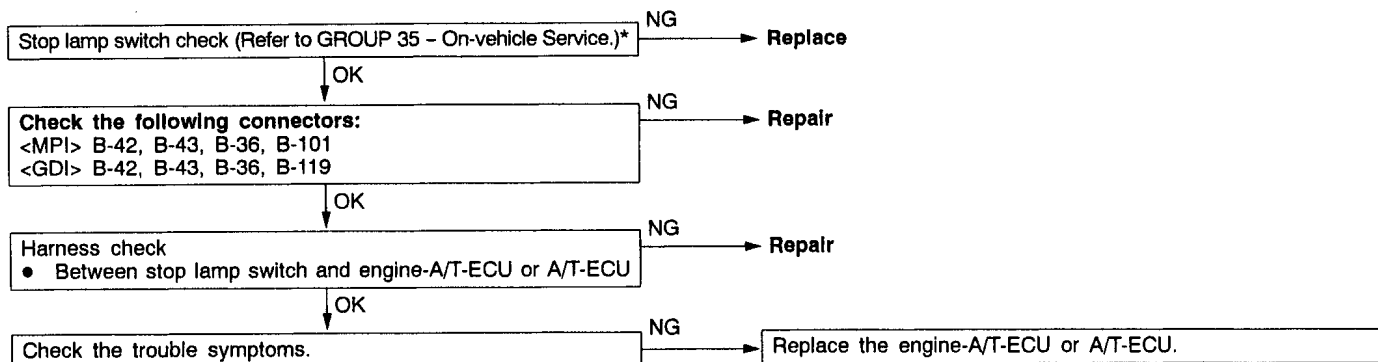

<b>Code No. 31 Low and reverse solenoid valve system</b>	<b>Probable cause</b>
<b>Code No. 32 Underdrive solenoid valve system</b>	
<b>Code No. 33 Second solenoid valve system</b>	
<b>Code No. 34 Overdrive solenoid valve system</b>	
If the resistance value for a solenoid valve is too large or too small, it is judged that there is a short-circuit or an open circuit in the solenoid valve and the respective diagnosis code is output. The transmission is locked into 3rd gear as a fail-safe measure, and the N range lamp flashes at a frequency of 1 Hz.	

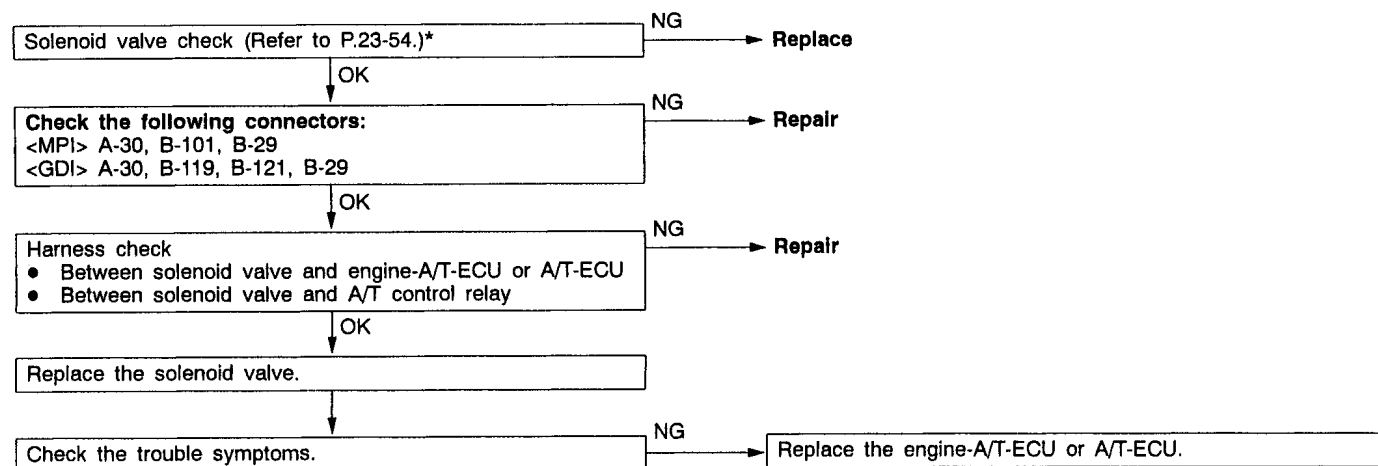

**NOTE**

\*: Refer to '96 CARISMA Workshop Manual (Pub No. PWDE9502).

Code No. 36, 52 Damper clutch control solenoid valve system	Probable cause
<p>If the resistance value for the damper clutch control solenoid valve is too large or too small, it is judged that there is a short-circuit or an open circuit in the damper clutch control solenoid valve and diagnosis code No. 36 is output. If the drive duty rate for the damper clutch control solenoid valve is 100 % for a continuous period of 4 seconds or more, it is judged that there is an abnormality in the damper clutch control system and diagnosis code No. 52 is output. When diagnosis code No. 36 is output, the transmission is locked into 3rd gear as a fail-safe measure, and the N range lamp flashes at a frequency of 1 Hz.</p>	<ul style="list-style-type: none"> <li>● Malfunction of the damper clutch control solenoid valve</li> <li>● Malfunction of connector</li> <li>● Malfunction of the engine-A/T-ECU &lt;MPI&gt;</li> <li>● Malfunction of the A/T-ECU &lt;GDI&gt;</li> </ul>

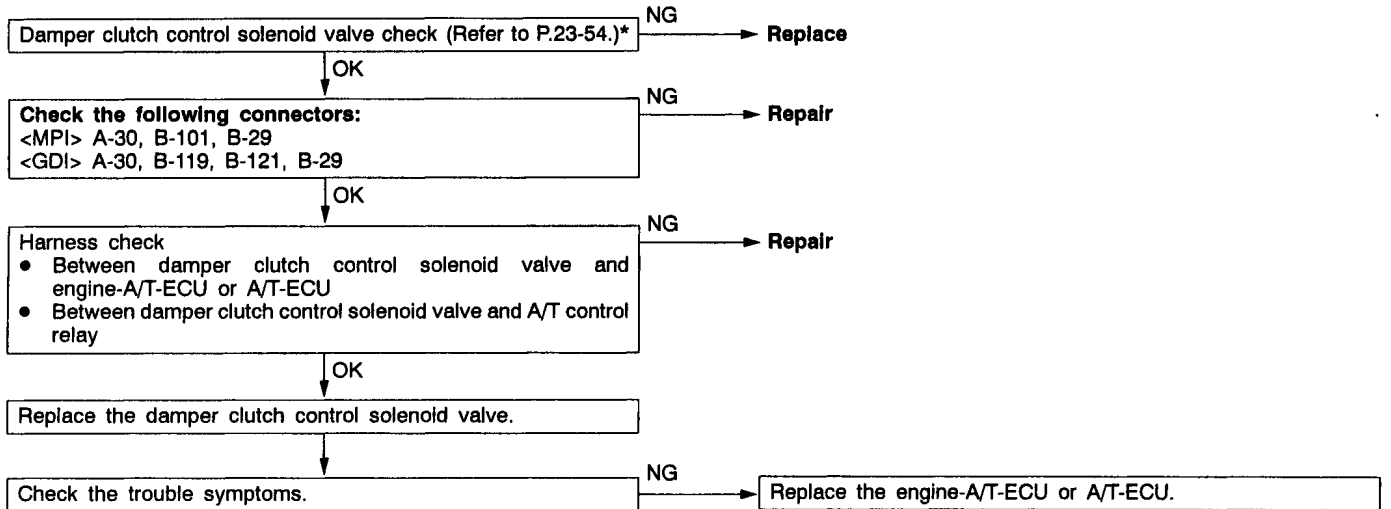

NOTE

\*: Refer to '96 CARISMA Workshop Manual (Pub No. PWDE9502).

Code No. 41 1st gear ratio does not meet the specification	Probable cause
Code No. 42 2nd gear ratio does not meet the specification	
Code No. 43 3rd gear ratio does not meet the specification	
Code No. 44 4th gear ratio does not meet the specification	
Code No. 46 Reverse gear ratio does not meet the specification	
<p>If the output from the output shaft speed sensor multiplied by each gear ratio is not the same as the output from the input shaft speed sensor after shifting to each gear has been completed, each diagnosis code is output. If each diagnosis code is output four times, the transmission is locked into 3rd gear as a fail-safe measure, and the N range lamp flashes at a frequency of 1 Hz.</p>	<ul style="list-style-type: none"> <li>● Malfunction of the input shaft speed sensor</li> <li>● Malfunction of the output shaft speed sensor</li> <li>● Malfunction of the underdrive clutch retainer</li> <li>● Malfunction of the transfer drive gear or driven gear</li> <li>● Malfunction of the low and reverse brake system (for code No.41, 46)</li> <li>● Malfunction of the underdrive clutch system (for code No.41, 42, 43)</li> <li>● Malfunction of the second brake system (for code No.42, 44)</li> <li>● Malfunction of the overdrive clutch system (for code No.43, 44)</li> <li>● Malfunction of the reverse clutch system (for code No.46)</li> <li>● Noise generated</li> </ul>

★: Refer to the Transmission Workshop Manual.

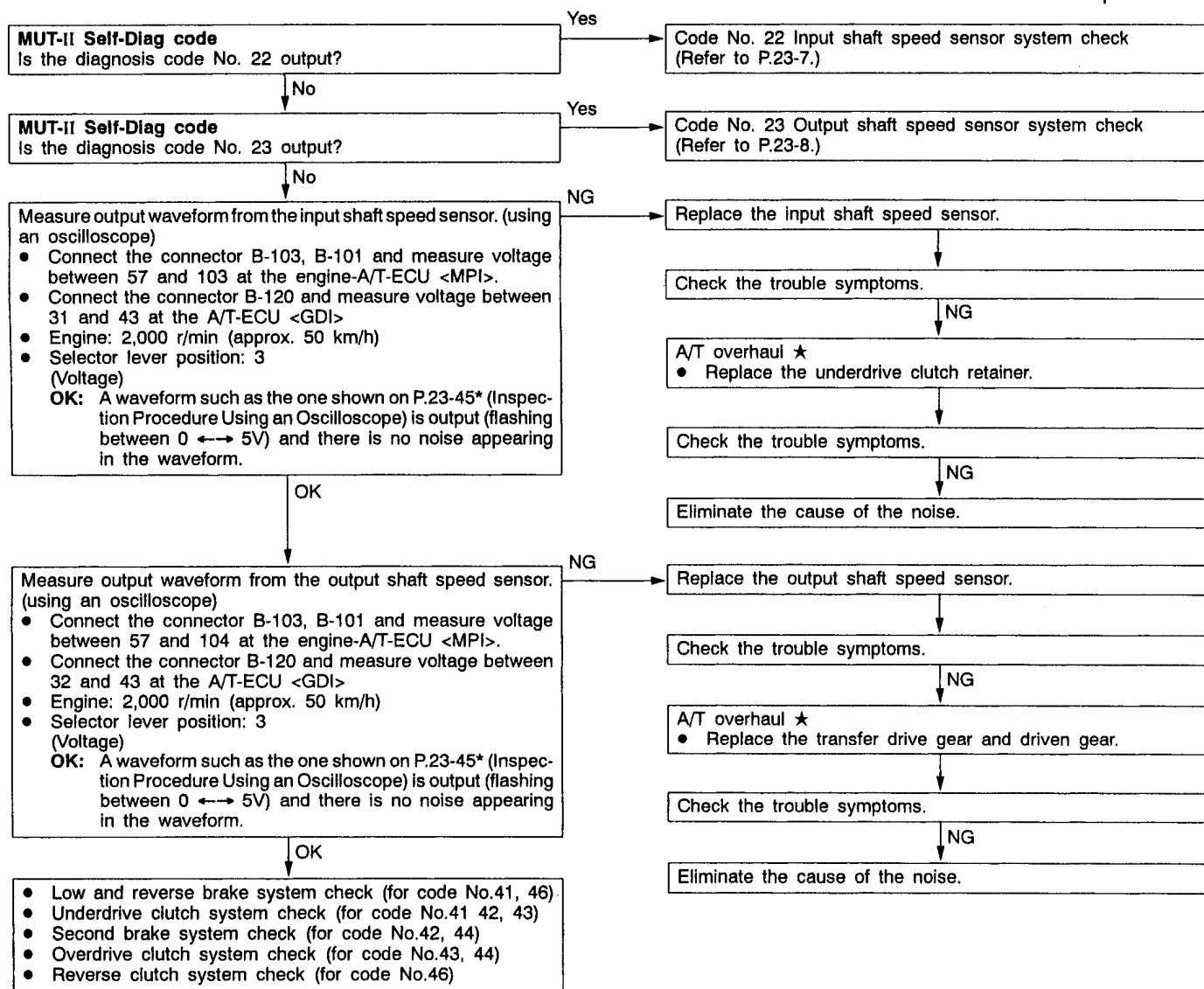

NOTE

\*: Refer to '96 CARISMA Workshop Manual (Pub No. PWDE9502).

Code No. 51 Abnormal communication with engine-ECU	Probable cause
If normal communication is not possible for a continuous period of 1 second or more when the ignition switch is at the ON position, the battery voltage is 10 V or more and the engine speed is 450 r/min or more, diagnosis code No. 51 is output. Diagnosis code No. 51 is also output if the data being received is abnormal for a continuous period of 4 seconds under the same conditions.	<ul style="list-style-type: none"> <li>● Malfunction of connector</li> <li>● Malfunction of the engine-A/T-ECU &lt;MPI&gt;</li> <li>● Malfunction of the A/T-ECU &lt;GDI&gt;</li> <li>● Malfunction of the engine-ECU &lt;GDI&gt;</li> </ul>

<MPI>

Replace the engine-A/T-ECU.

<GDI>

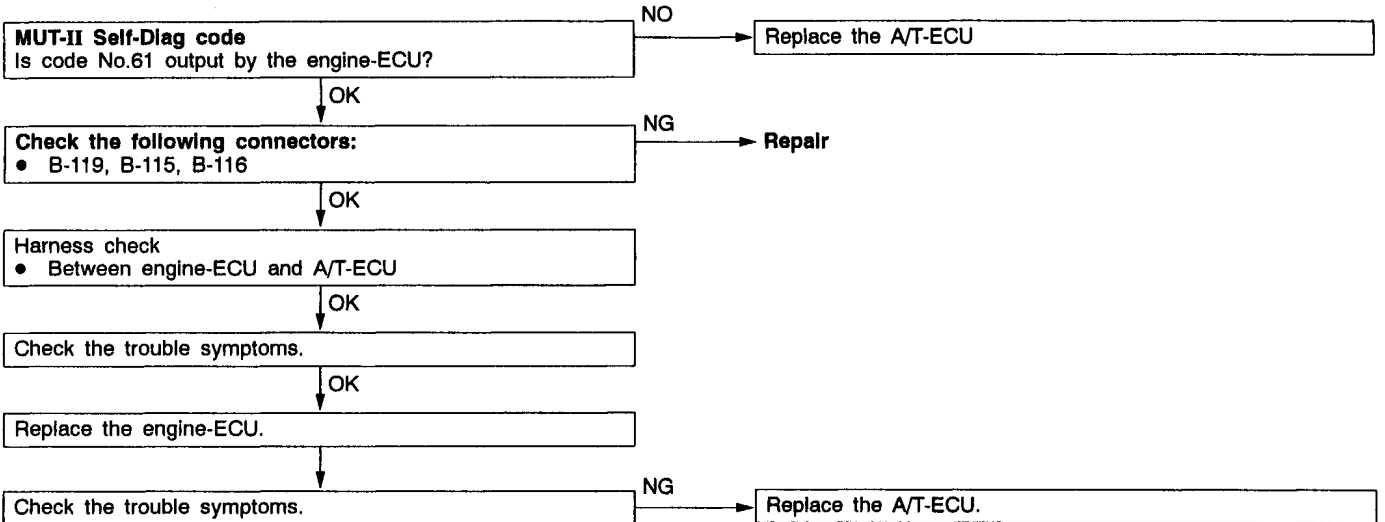

Code No. 54 A/T control relay system	Probable cause
If the A/T control relay voltage is less than 7 V after the ignition switch has been turned ON, it is judged that there is an open circuit or a short-circuit in the A/T control relay earth and diagnosis code No. 54 is output. Then the transmission is locked into 3rd gear as a fail-safe measure, and the N range lamp flashes at a frequency of 1 Hz.	<ul style="list-style-type: none"> <li>● Malfunction of the A/T control relay</li> <li>● Malfunction of connector</li> <li>● Malfunction of the engine-A/T-ECU &lt;MPI&gt;</li> <li>● Malfunction of the A/T-ECU &lt;GDI&gt;</li> </ul>

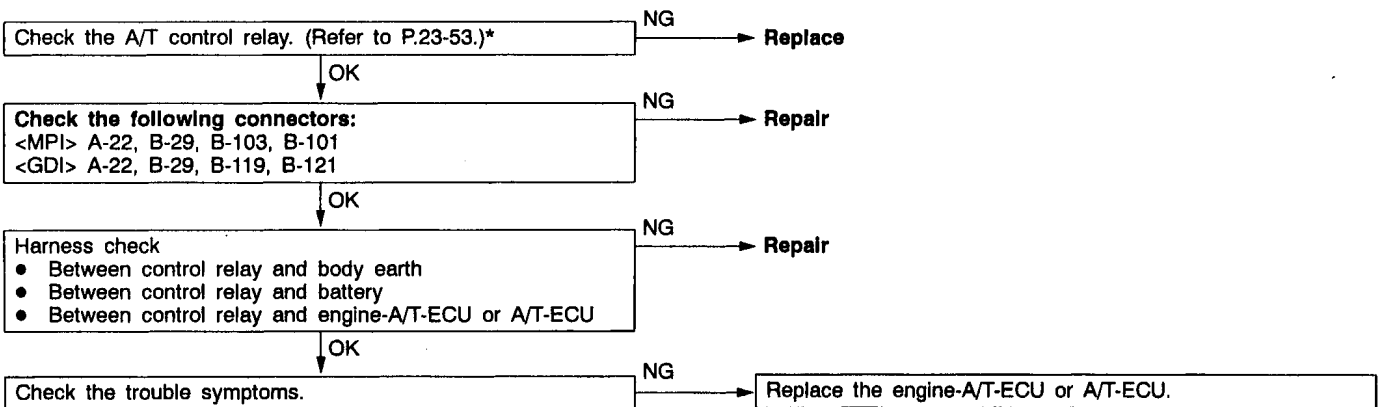

NOTE

\*: Refer to '96 CARISMA Workshop Manual (Pub No. PWDE9502).

Code No. 56 N range lamp system	Probable cause
If the N range signal is off after an N range lamp illumination instruction (ON instruction) has been given, it is judged that there is a short-circuit in the N range lamp earth and diagnosis code No. 56 is output.	<ul style="list-style-type: none"> <li>● Malfunction of the N range lamp bulb</li> <li>● Malfunction of connector</li> <li>● Malfunction of the engine-A/T-ECU &lt;MPI&gt;</li> <li>● Malfunction of the A/T-ECU &lt;GDI&gt;</li> </ul>

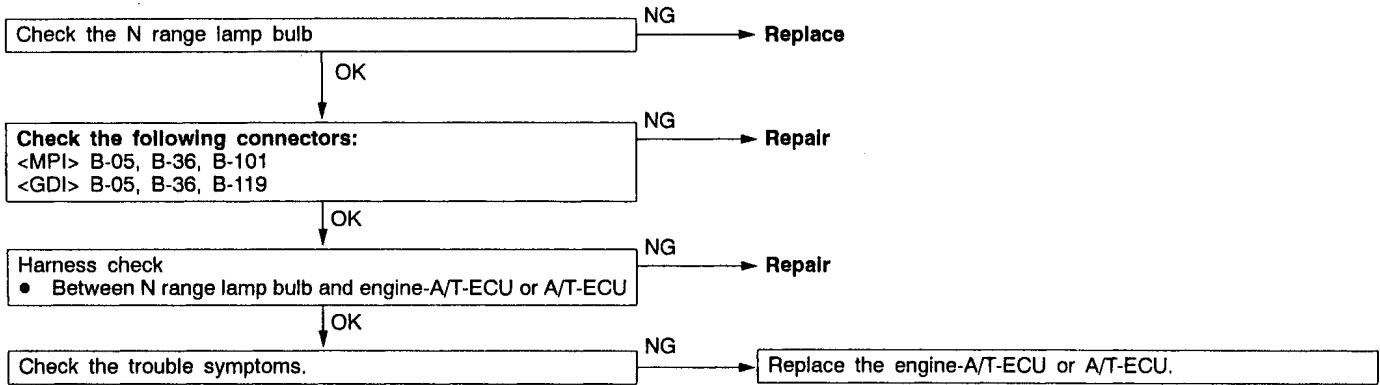

**INSPECTION CHART FOR TROUBLE SYMPTOMS**

Trouble symptom	Inspection procedure No.	Reference page
Communication with MUT-II is not possible	1	23-14
Driving impossible	Starting impossible	2
	Does not move forward	3
	Does not reverse	4
	Does not move (forward or reverse)	5
Malfunction when starting	Engine stalling when shifting	6
	Shocks when changing from N to D and large time lag	7
	Shocks when changing from N to R and large time lag	8
	Shocks when changing from N to D, N to R and large time lag	9
Malfunction when shifting	Shocks and running up	10
Displaced shifting points	All points	11
	Some points	12
Does not shift	No diagnosis codes	13
Malfunction while driving	Poor acceleration	14
	Vibration	15
Inhibitor switch system	16	23-15
Mode control switch system	17	23-16
Dual pressure switch system	18	23-16

Trouble symptom	Inspection procedure No.	Reference page
Vehicle speed sensor system	19	23-17

NOTE

\*: Refer to '96 CARISMA Workshop Manual (Pub No. PWDE9502).

INSPECTION PROCEDURE FOR TROUBLE SYMPTOMS

INSPECTION PROCEDURE 1

Communication with MUT-II is not possible	Probable cause
If communication with the MUT-II is not possible, the cause is probably a defective diagnosis line or the A/T-ECU is not functioning.	<ul style="list-style-type: none"> <li>● Malfunction of diagnosis line</li> <li>● Malfunction of connector</li> <li>● Malfunction of the engine-A/T-ECU &lt;MPI&gt;</li> <li>● Malfunction of the A/T-ECU &lt;GDI&gt;</li> </ul>

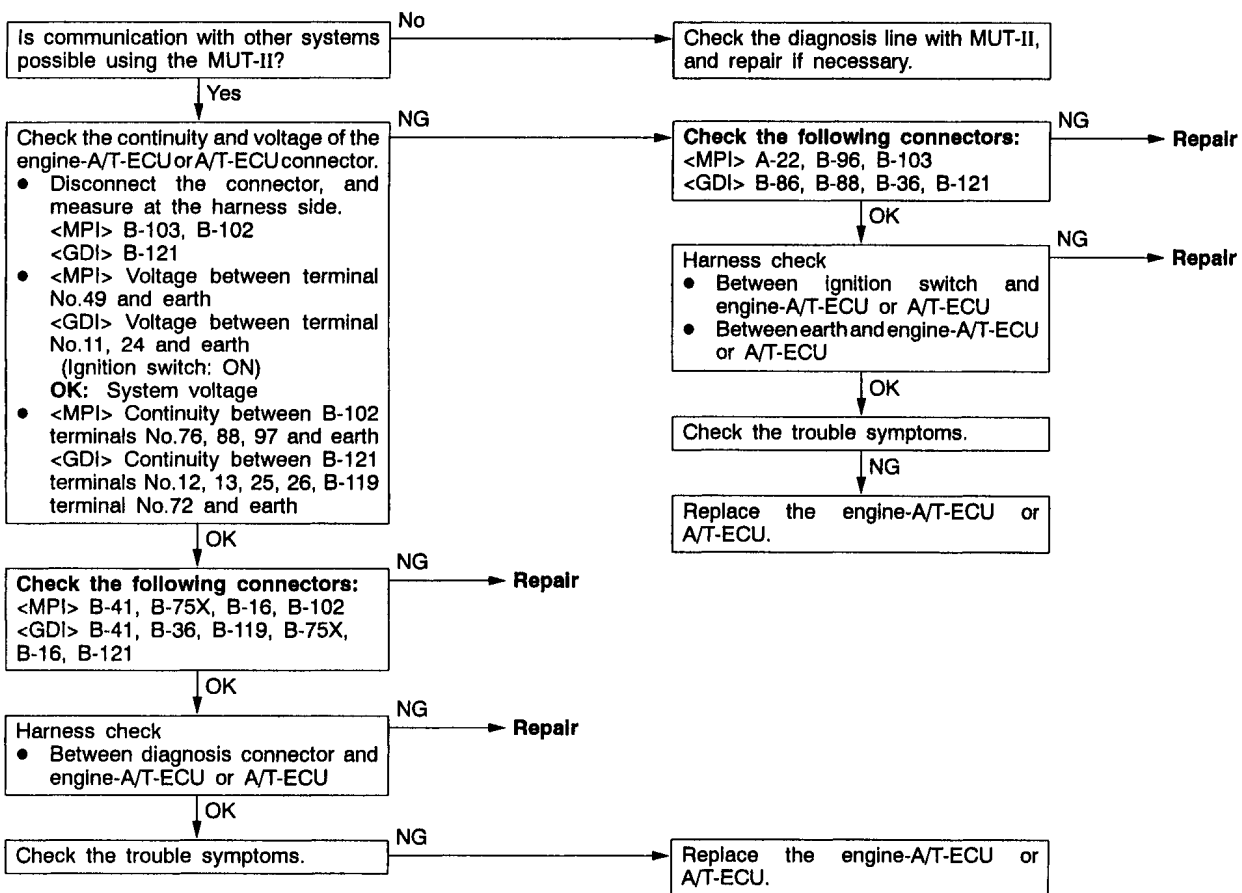

INSPECTION PROCEDURE 16

Inhibitor switch system	Probable cause
The cause is probably a malfunction of the inhibitor switch circuit, ignition switch circuit or a defective engine-A/T-ECU or A/T-ECU.	<ul style="list-style-type: none"> <li>• Malfunction of the inhibitor switch</li> <li>• Malfunction of the ignition switch</li> <li>• Malfunction of connector</li> <li>• Malfunction of the engine-A/T-ECU &lt;MPI&gt;</li> <li>• Malfunction of the A/T-ECU &lt;GDI&gt;</li> </ul>

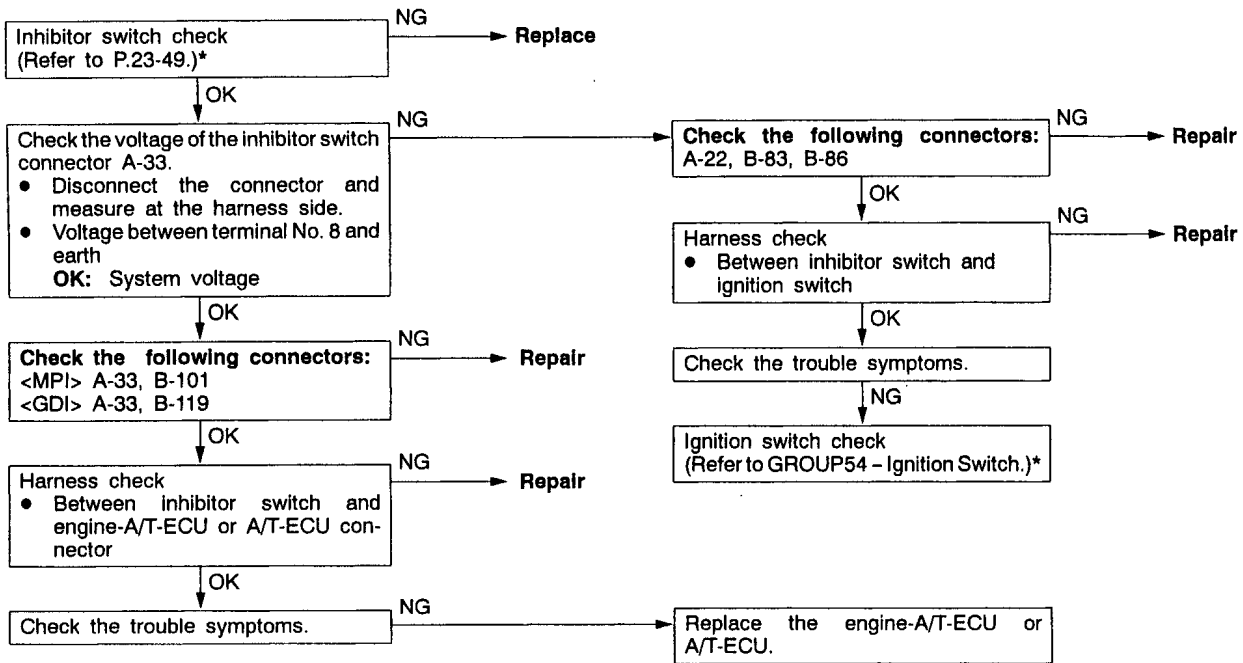

NOTE

\*: Refer to '96 CARISMA Workshop Manual (Pub No. PWDE9502).

**INSPECTION PROCEDURE 17**

Mode control switch system	Probable cause
The cause is probably a defective mode control switch circuit or a defective engine-A/T-ECU or A/T-ECU.	<ul style="list-style-type: none"> <li>• Malfunction of the mode control switch</li> <li>• Malfunction of connector</li> <li>• Malfunction of the engine-A/T-ECU &lt;MPI&gt;</li> <li>• Malfunction of the A/T-ECU &lt;GDI&gt;</li> </ul>

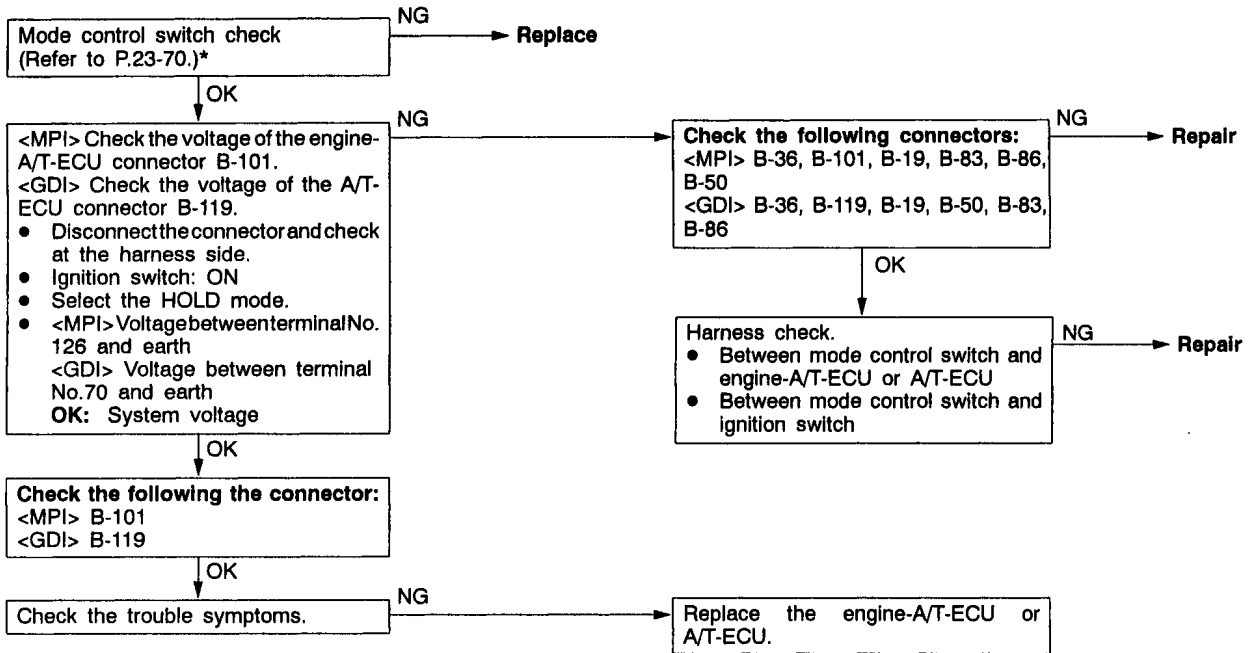

**INSPECTION PROCEDURE 18**

Dual pressure switch system	Probable cause
The cause is probably a defective dual pressure switch circuit or a defective engine-A/T-ECU or A/T-ECU.	<ul style="list-style-type: none"> <li>• Malfunction of the dual pressure switch</li> <li>• Malfunction of connector</li> <li>• Malfunction of A/C system</li> <li>• Malfunction of the engine-A/T-ECU &lt;MPI&gt;</li> <li>• Malfunction of the A/T-ECU &lt;GDI&gt;</li> </ul>

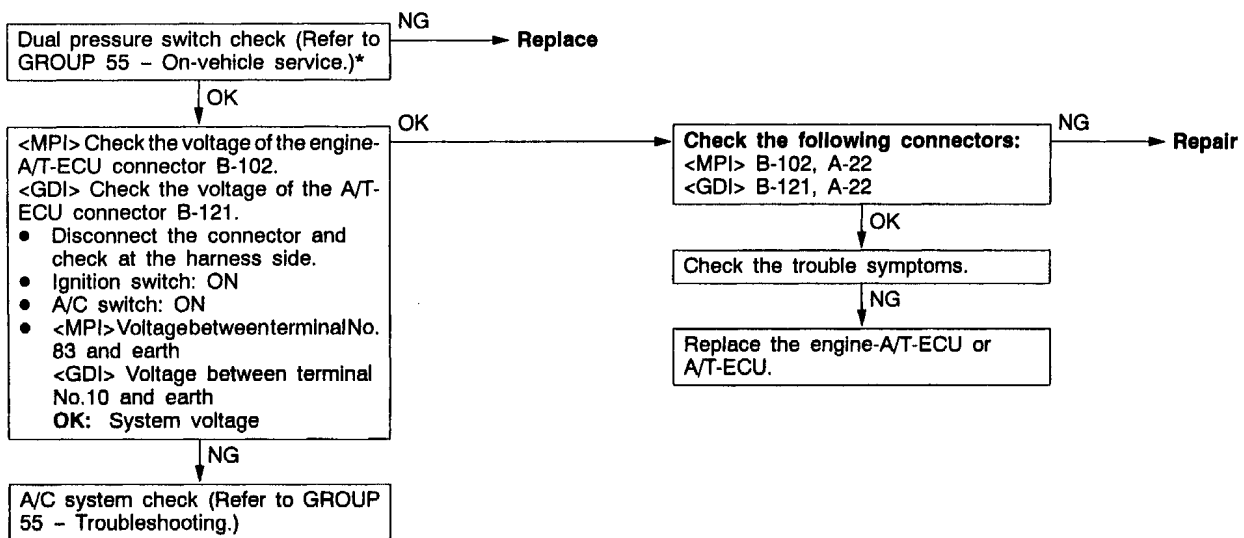

**NOTE**

\*: Refer to '96 CARISMA Workshop Manual (Pub No. PWDE9502).



INSPECTION PROCEDURE 19

Vehicle speed sensor system	Probable cause
The cause is probably a defective vehicle speed sensor circuit or a defective engine-A/T-ECU or A/T-ECU.	<ul style="list-style-type: none"> <li>● Malfunction of the vehicle speed sensor</li> <li>● Malfunction of connector</li> <li>● Malfunction of the engine-A/T-ECU &lt;MPI&gt;</li> <li>● Malfunction of the A/T-ECU &lt;GDI&gt;</li> </ul>

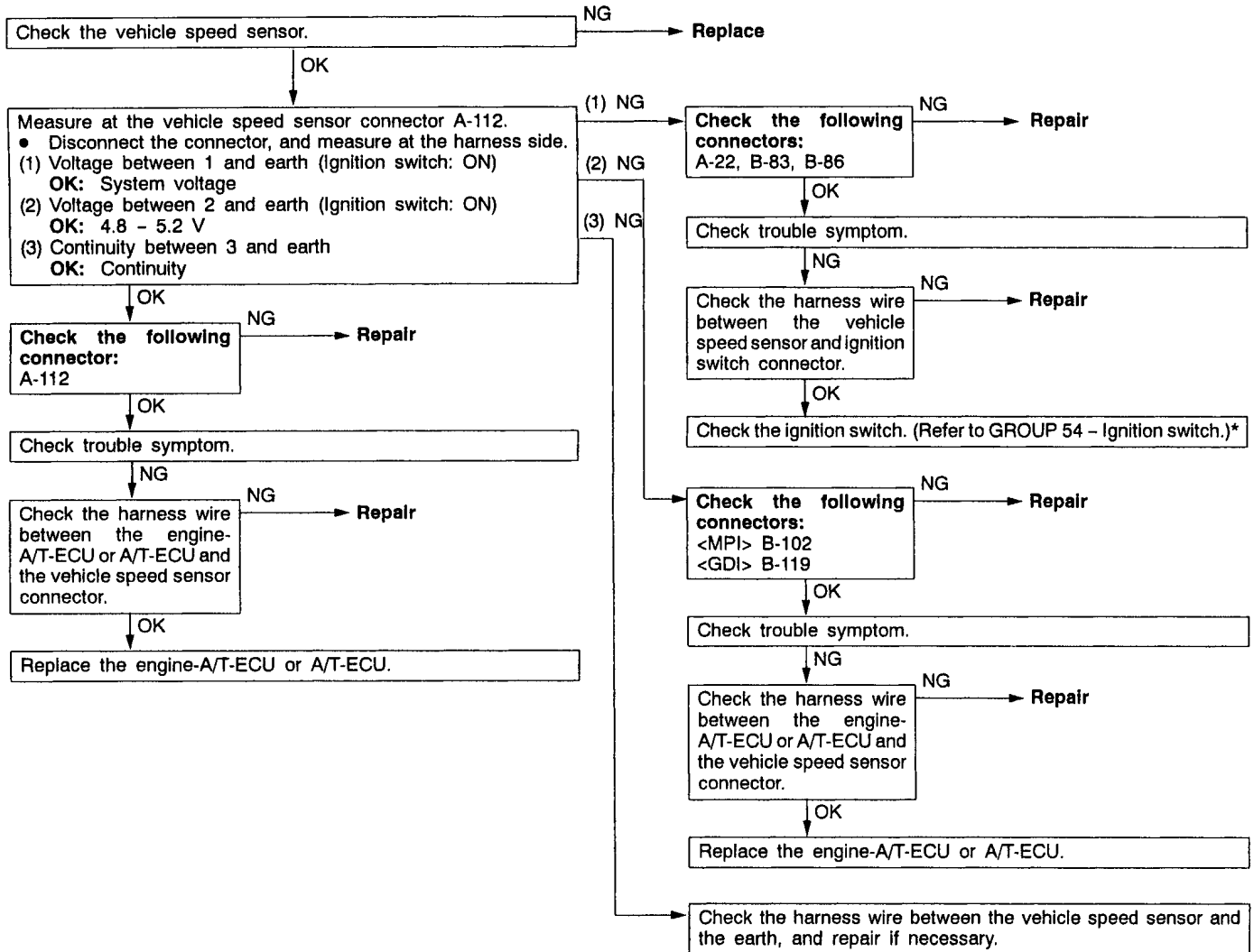

NOTE

\*: Refer to '96 CARISMA Workshop Manual (Pub No. PWDE9502).

## CHECK AT A/T-ECU TERMINALS &lt;GDI&gt;

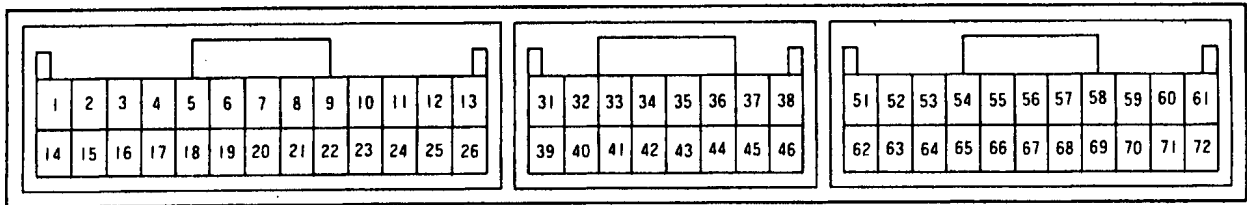

A9FA0133

Terminal No.	Check item	Check requirement	Standard value
1	Underdrive solenoid valve	Selector lever position: D (1st gear)	System voltage
		Selector lever position: P	Approx. 7 – 9 V
2	Solenoid valve power supply	Ignition switch: OFF	0 V
		Ignition switch: ON	System voltage
3	Solenoid valve power supply	Ignition switch: OFF	0 V
		Ignition switch: ON	System voltage
10	A/C compressor load signal	A/C switch: OFF	0 V
		A/C switch: ON	System voltage
11	Power supply	Ignition switch: OFF	0 V
		Ignition switch: ON	System voltage
12	Earth	Always	0 V
13	Earth	Always	0 V
14	Overdrive solenoid valve	Selector lever position: D (3rd gear)	System voltage
		Selector lever position: P	Approx. 7 – 9 V
15	Damper clutch control solenoid valve	Selector lever position: L (1st gear)	System voltage
		Selector lever position: 3 (50 km/h in 3rd gear)	Other than system voltage
16	Second solenoid valve	Selector lever position: 2 (2nd gear)	System voltage
		Selector lever position: P	Approx. 7 – 9 V
23	Diagnosis control	–	–

Terminal No.	Check item	Check requirement	Standard value
24	Power supply	Ignition switch: OFF	0 V
		Ignition switch: ON	System voltage
25	Earth	Always	0 V
26	Earth	Always	0 V
31	Input shaft speed sensor	Measure between terminal No. 31 and No. 43 by an oscilloscope. Engine: 2,000 r/min Selector lever position: 3	Refer to P.23-45*, Oscilloscope inspection procedure.
32	Output shaft speed sensor	Measure between terminal No. 32 and No. 43 by an oscilloscope. Engine: 2,000 r/min Selector lever position: 3	Refer to P.23-45*, Oscilloscope inspection procedure.
33	Crank angle sensor	Engine: Idling	2.0 – 2.4 V
38	Back up power supply	Ignition switch: OFF	System voltage
43	Sensor earth	Always	0 V
44	Oil temperature sensor	ATF temperature: 25 °C	3.8 – 4.0 V
		ATF temperature: 80 °C	2.3 – 2.5 V
45	Accelerator pedal position sensor (APS)	Accelerator pedal: Released (Engine stopped)	0.5 – 1.0 V
		Accelerator pedal: Depressed (Engine stopped)	4.5 – 5.0 V
53	Communication with engine-ECU	Engine: Idling Selector lever position: D	Other than 0 V
54	Communication with engine-ECU	Engine: Idling Selector lever position: D	Other than 0 V
55	Inhibitor switch P	Selector lever position: P	System voltage
		Selector lever position: Other than above	0 V
56	Inhibitor switch N	Selector lever position: N	System voltage
		Selector lever position: Other than above	0 V
57	Inhibitor switch 3	Selector lever position: 3	System voltage
		Selector lever position: Other than above	0 V
58	Inhibitor switch L	Selector lever position: L	System voltage
		Selector lever position: Other than above	0 V

**NOTE**

\*: Refer to '96 CARISMA Workshop Manual (Pub No. PWDE9502).

Terminal No.	Check item	Check requirement	Standard value
59	Stop lamp switch	Brake pedal: Depressed	System voltage
		Brake pedal: Released	0 V
62	Low and reverse solenoid valve	Selector lever position: D (1st gear)	System voltage
		Selector lever position: D (2nd gear)	Approx. 7 – 9 V
63	Diagnosis output	Normal (No diagnosis code output)	0 → 5 V flashing
65	Wide open throttle switch	Accelerator pedal: Released	4.5 → 5.5 V
		Accelerator pedal: Depressed	Less than 0.4 V
66	Inhibitor switch R	Selector lever position: R	System voltage
		Selector lever position: Other than above	0 V
67	Inhibitor switch D	Selector lever position: D	System voltage
		Selector lever position: Other than above	0 V
68	Inhibitor switch 2	Selector lever position: 2	System voltage
		Selector lever position: Other than above	0 V
69	Vehicle speed sensor	When stopped	0 V
		Move forward slowly	0 → 5 V flashing
71	A/T control relay	Ignition switch: OFF	0 V
		Ignition switch: ON	System voltage
72	Earth	Ignition switch: ON	0 V

CHECK AT ENGINE-A/T-ECU TERMINALS <MPI>

1	2	3	4		5	6	7	8	41	42	43		44	45	46	71	72	73	74		75	76	77	101	102	103	104		105	106	107																			
9	10	11	12	13	14	15	16	17	18	19	20	21	22	23	47	48	49	50	51	52	53	54	55	56	57	78	79	80	81	82	83	84	85	86	87	88	89	108	109	110	111	112	113	114	115	116	117	118	119	120
24	25	26	27	28	29	30	31	32	33	34	35	58	59	60	61	62	63	64	65	66	90	91	92	93	94	95	96	97	98	121	122	123	124	125	126	127	128	129	130											

9FA0253

Terminal No.	Check item	Check requirement	Standard value
50	A/T control relay	Ignition switch: OFF	0 V
		Ignition switch: ON	System voltage
57	Sensor earth	Always	0 V
76	Earth	Always	0 V
77	Solenoid valve power supply	Ignition switch: OFF	0 V
		Ignition switch: ON	System voltage
88	Earth	Always	0 V
89	Solenoid valve power supply	Ignition switch: OFF	0 V
		Ignition switch: ON	System voltage
97	Earth	Always	0 V
101	Inhibitor switch P	Selector lever position: P	System voltage
		Selector lever position: Other than above	0 V
102	Inhibitor switch D	Selector lever position: D	System voltage
		Selector lever position: Other than above	0 V
103	Input shaft speed sensor	Measure between terminal No. 57 and No. 103 by an oscilloscope. Engine: 2,000 r/min Selector lever position: 3 (3rd gear)	Refer to P.23-45*, Oscilloscope inspection procedure.
104	Output shaft speed sensor	Measure between terminal No. 57 and No. 104 by an oscilloscope. Engine: 2,000 r/min Selector lever position: 3 (3rd gear)	Refer to P.23-45*, Oscilloscope inspection procedure.
106	Second solenoid valve	Selector lever position: 2 (2nd gear)	System voltage
		Selector lever position: P	Approx. 7 – 9 V
107	Damper clutch control solenoid valve	Selector lever position: L (1st gear)	System voltage
		Selector lever position: 3 (50 km/h in 3rd gear)	Other than System voltage

NOTE

\*: Refer to '96 CARISMA Workshop Manual (Pub No. PWDE9502).

Terminal No.	Check item	Check requirement	Standard value
108	Inhibitor switch R	Selector lever position: R	System voltage
		Selector lever position: Other than above	0 V
109	Inhibitor switch 3	Selector lever position: 3	System voltage
		Selector lever position: Other than above	0 V
110	Inhibitor switch L	Selector lever position: L	System voltage
		Selector lever position: Other than above	0 V
115	Wide open throttle switch	Accelerator pedal: Released	4 V or more
		Accelerator pedal: Depressed	Less than 0.4 V
120	Underdrive solenoid valve	Selector lever position: L (1st gear)	System voltage
		Selector lever position: P	Approx. 7 – 9 V
121	Inhibitor switch N	Selector lever position: N	System voltage
		Selector lever position: Other than above	0 V
122	Inhibitor switch 2	Selector lever position: 2	System voltage
		Selector lever position: Other than above	0 V
123	Stop lamp switch	Brake pedal: Depressed	System voltage
		Brake pedal: Released	0 V
124	Oil temperature sensor	ATF temperature: 25 °C	3.8 – 4.0 V
		ATF temperature: 80 °C	2.3 – 2.5 V
126	Mode control switch	Select HOLD mode	System voltage
		Select AUTO mode	0V
129	Low and reverse solenoid valve	Selector lever position: P	System voltage
		Selector lever position: 2 (2nd gear)	Approx. 7 – 9 V
130	Overdrive solenoid valve	Selector lever position: 3 (3rd gear)	System voltage
		Selector lever position: P	Approx. 7 – 9 V

## ON-VEHICLE SERVICE

### A/T CONTROL COMPONENT LOCATION

The diagnosis connector has been removed from the driver side to the passenger side.

Name	Symbol
Diagnosis connector	T

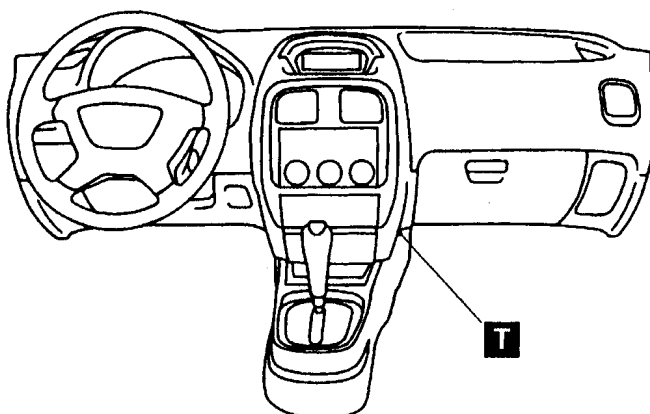

AX00898N

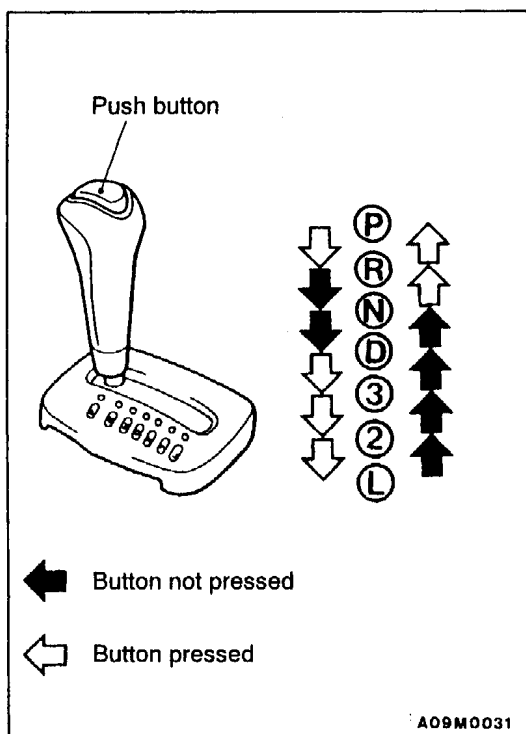

### SELECTOR LEVER OPERATION CHECK

1. Shift selector lever to each range and check that lever moves smoothly and is controlled. Check that position indicator is correct.
2. Check the selector lever can be moved to each position (by button operation as shown in the illustration).
3. Start the engine and check if the vehicle moves forward when the selector lever is moved from N or D, and moves backward when moved to R.
4. When the shift lever malfunctions, adjust control cable and selector lever sleeve. Check for worm shift lever assembly sliding parts.

## TRANSMISSION CONTROL

### REMOVAL AND INSTALLATION

**Caution: SRS**

Be careful not to subject the SRS-ECU to any shocks during removal and installation of the transmission control cable and selector lever assembly.

**Pre-removal and Post-Installation Operation**

- Front Floor Console Assembly Removal and Installation (Refer to GROUP 52A.)

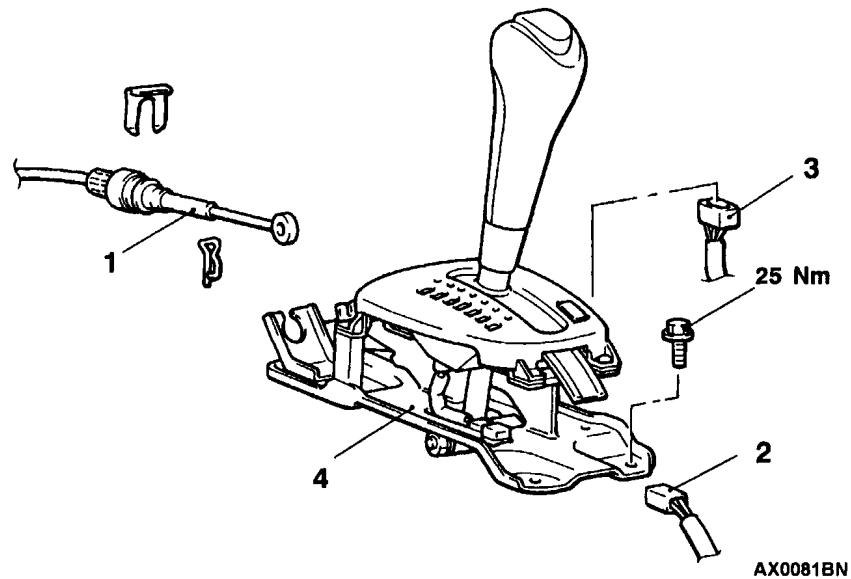
**Removal steps**

1. Transmission control cable connection
2. Shift indicator illumination lamp connector
3. Hold switch connector
4. Selector lever assembly



**SELECTOR LEVER ASSEMBLY  
DISASSEMBLY AND REASSEMBLY**

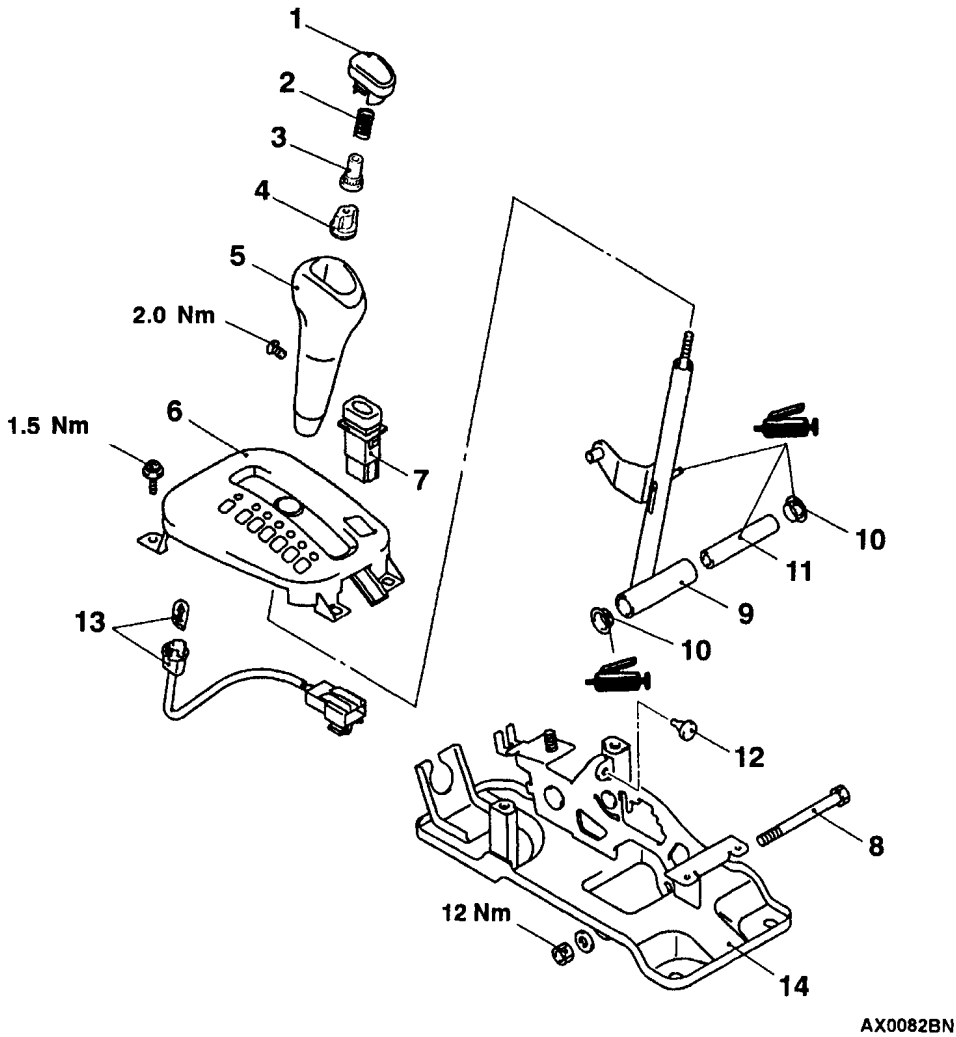

AX0082BN

**Disassembly steps**

- |                             |  |
|-----------------------------|--|
| 1. Push button              | 9. Shift lever assembly                        |
| 2. Spring                   | 10. Bushing                                    |
| 3. Bumper                   | 11. Pipe                                       |
| 4. Adjuster                 | 12. Stopper                                    |
| 5. Selector knob            | 13. Shift indicator illumination lamp assembly |
| 6. Indicator panel assembly | 14. Bracket assembly                           |
| 7. Hold switch              |  |
| 8. Bolt                     |  |

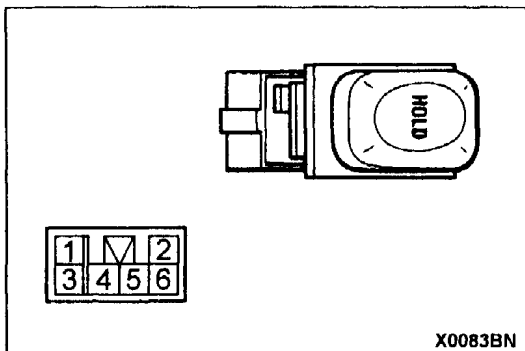

X0083BN

**INSPECTION  
HOLD SWITCH CHECK**

Switch position	Terminal No.					
	1	2	5	3		6
OFF	○	—	○		○	○
ON	○	○		○	Ⓢ	○