

---

# FRONT SUSPENSION

## CONTENTS

<b>GENERAL</b> .....	2	<b>STRUT ASSEMBLY</b> .....	4
Outline of Changes .....	2	<b>LOWER ARM</b> .....	7
<b>SERVICE SPECIFICATIONS</b> .....	2	<b>STABILIZER BAR</b> .....	9
<b>SPECIAL TOOLS</b> .....	2		
<b>ON-VEHICLE SERVICE</b> .....	3		
Front Wheel Alignment Check and Adjustment .....	3		

## 33A-2 FRONT SUSPENSION – General/Service Specifications/Special Tools

### GENERAL

#### OUTLINE OF CHANGES

- Spring specifications have been changed.
- The following items have been revised to correspond to the change of the front stabilizer.
  - (1) Strut assembly removal and installation.
  - (2) Lower arm assembly removal and installation.
  - (3) Stabilizer bar removal and installation.
- Disassembly and reassembly procedures for the strut assembly have been changed.

#### COIL SPRING

Items	1600 – M/T	1600 – A/T, 1800, 1900D
Wire dia. × O.D. × free length mm	13 × 160 × 374	13 × 160 × 384

### SERVICE SPECIFICATIONS

Items		Standard value
Toe-in	At the centre of tyre tread mm	0 ± 2
	Toe-angle (per wheel)	0°00' ± 06'
Toe-out angle on turns (inner wheel when outer wheel at 20°)		18°34'
Steering angle	Inner wheel	37°30' ± 1°30'
	Outer wheel	31°36'
Camber		-0°40' ± 30'
Caster		2°54'
Kingpin inclination		13°36'
Lower arm ball joint starting torque Nm		1.0 – 5.9
Lower arm ball joint turning torque Nm		1.0 – 3.9
Protruding length of stabilizer bar mounting bolt mm		22

### SPECIAL TOOLS

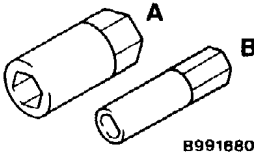
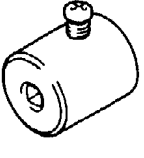
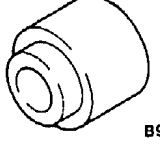
Tools	Number	Name	Use
	A: MB991619 B: MB991682	A: Wrench B: Socket	Strut assembly disassembly and reassembly
	MB991006	Preload socket	Lower arm ball joint rotation torque measurement
	MB990800	Ball joint remover and installer	Lower arm ball joint dust cover installation

## ON-VEHICLE SERVICE

### FRONT WHEEL ALIGNMENT CHECK AND ADJUSTMENT

The wheel alignment standard values have been revised as follows. The inspection and adjustment procedures are the same as before.

#### TOE-IN

**Standard value:**

At the centre of tyre tread  $0 \pm 2$  mm

Toe angle (per wheel)  $0^{\circ}00' \pm 06'$

#### TOE-OUT ANGLE ON TURNS

**Standard value:**

$18^{\circ}34'$  (inner wheel when outer wheel at  $20^{\circ}$ )

#### STEERING ANGLE

**Standard value:**

Inner wheel  $37^{\circ}30' \pm 1^{\circ}30'$

Outer wheel  $31^{\circ}36'$

#### CAMBER, CASTER AND KINGPIN INCLINATION

**Standard value:**

Camber –  $0^{\circ}40' \pm 30'$

Caster  $2^{\circ}54'$

Kingpin Inclination  $13^{\circ}36'$

**STRUT ASSEMBLY****REMOVAL AND INSTALLATION****Caution:**

Do not strike the speed sensor against other parts when removing or installing it. Otherwise the speed sensor will be damaged.

**Post-Installation Operation**  
Front Wheel Alignment Adjustment  
(Refer to P.33A-3.)

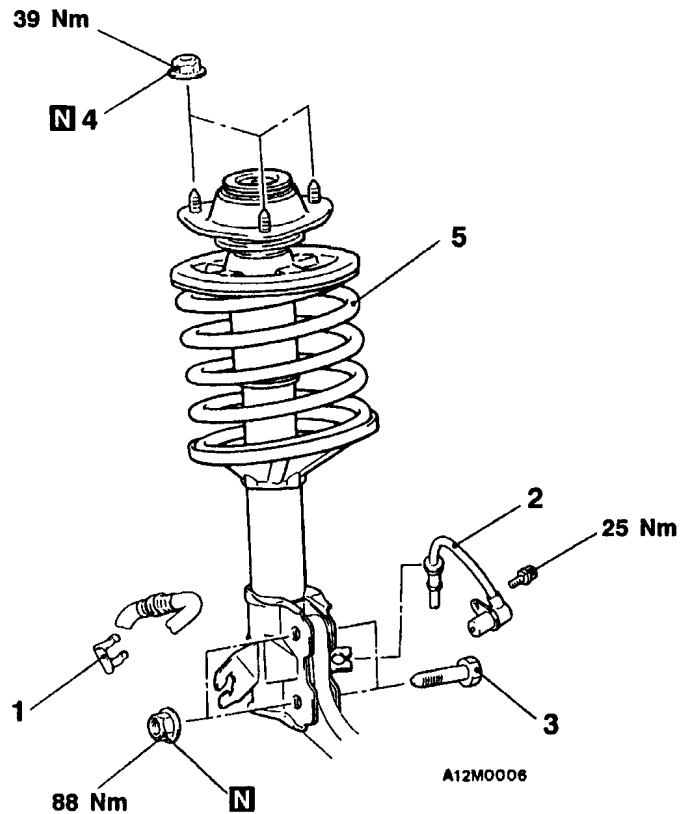
**Removal steps**

1. Brake hose clamp
2. Front speed sensor
3. Bolts

4. Self-locking nut
5. Strut assembly

**REMOVAL SERVICE POINT****◀A▶ BOLTS REMOVAL**

1. Suspend the lower arm from the vehicle with wire.
2. Separate the strut from the knuckle.

**INSPECTION**

- Check for oil leaks from the strut assembly.
- Check the strut assembly for damage or deformation.

DISASSEMBLY AND REASSEMBLY

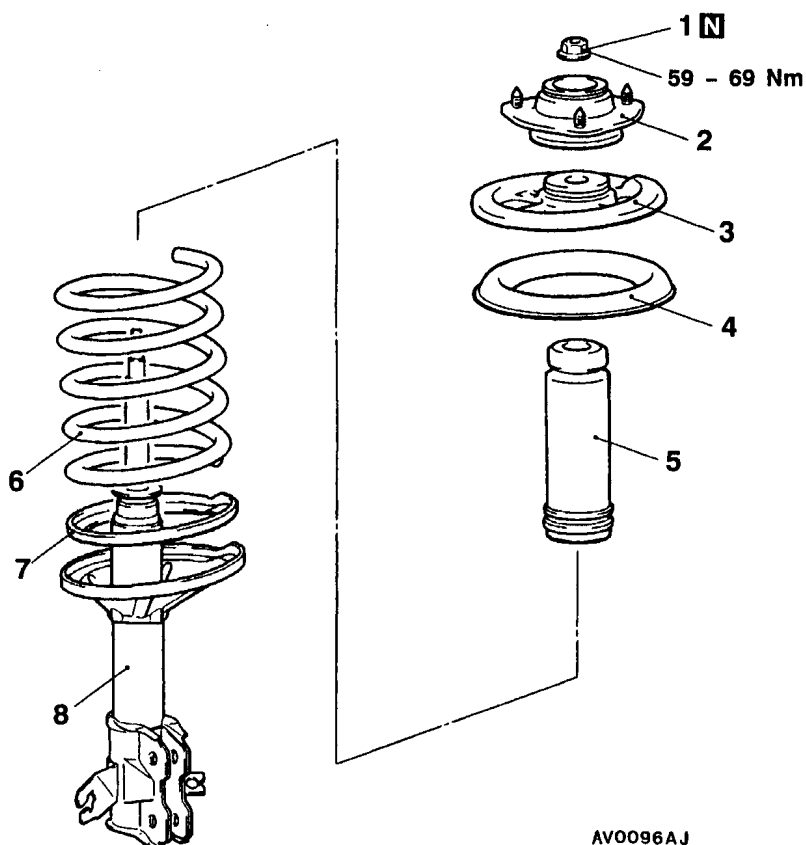

Disassembly steps



1. Self-locking nut
2. Strut insulator
3. Spring seat, upper
4. Spring pad, upper

5. Bump rubber
6. Coil spring
7. Spring pad, lower
8. Strut assembly

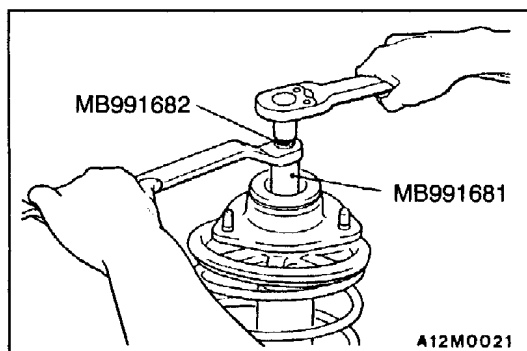
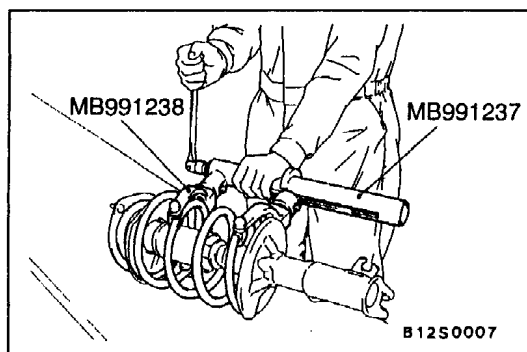

DISASSEMBLY SERVICE POINTS

◀A▶ SELF-LOCKING NUT REMOVAL

1. Use the special tools to compress the coil spring.

Caution

- (1) To compress the coil spring fully, install the special tools evenly, and so that the space between both arms of the special tool will be maximum within the installation range.
- (2) Do not use an impact wrench to tighten the special tool bolt, otherwise the special tool will break.

2. Use the special tools to remove the self-locking nut.

Caution

Do not use an impact wrench, otherwise the strut assembly internal parts will loose.

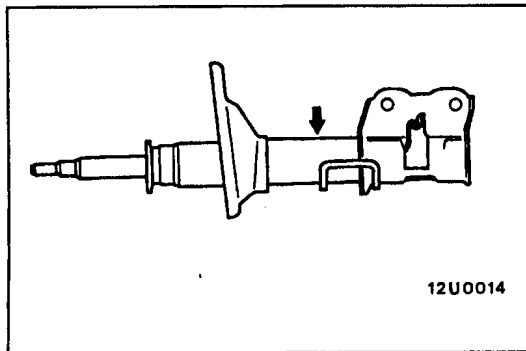

### ►B◄ STRUT ASSEMBLY REMOVAL

To discard the strut assembly, place the assembly horizontally with its piston rod extended. Then drill a hole approx. 3 mm in diameter at the location shown in the illustration and discharge the gas.

#### Caution

The gas itself is harmless but it may issue out of the hole together with chips generated by the drill. Therefore, be sure to wear goggles.

### REASSEMBLY SERVICE POINT

#### ►A◄ SELF-LOCKING NUT INSTALLATION

1. With the coil spring held compressed by the special tools (MB991237 and MB991238), provisionally tighten the self-locking nut.

#### Caution

Do not use an impact wrench to tighten the special tool bolt, otherwise the special tool will break.

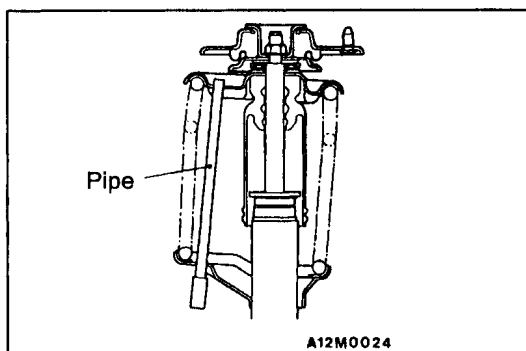

2. Line up the holes in the strut assembly spring lower seat with the hole in the spring upper seat.

#### NOTE

The job is easily accomplished with a pipe.

3. Correctly align both ends of the coil spring with the grooves in the spring seat, and then loosen the special tools (MB991237 and MB991238).

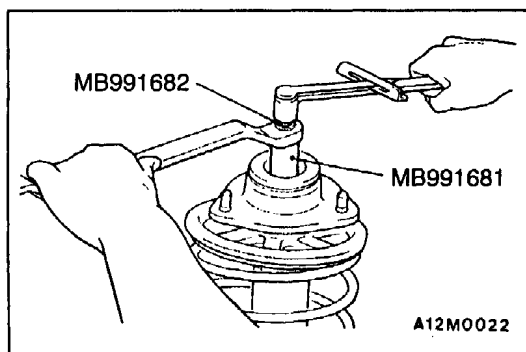

4. Using the special tools, tighten the self-locking nut to the specified torque.

#### Caution

Do not use an impact wrench, otherwise the strut assembly internal parts will loose.

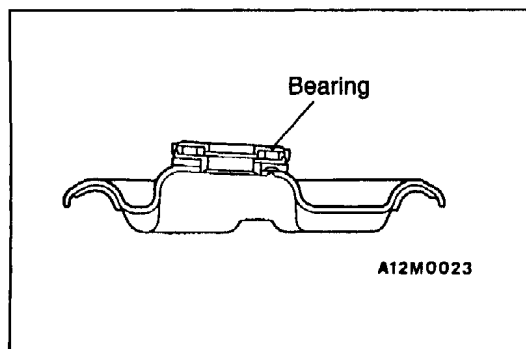

### INSPECTION

- Check the bearing for wear or rust.
- Check the rubber parts for damage or deterioration.
- Check the spring for deformation, deterioration or damage.
- Check the shock absorber for deformation.

# LOWER ARM

## REMOVAL AND INSTALLATION

**Caution:**

\*indicates parts which should be temporarily tightened, and then fully tightened with the vehicle on the ground in the unladen condition. Otherwise the bushing will be damaged.

**Post-Installation Operation**

- Check the Dust Cover for Cracks or Damaged by Pushing it with Finger.
- Front Wheel Alignment Adjustment (Refer to P.33A-3.)

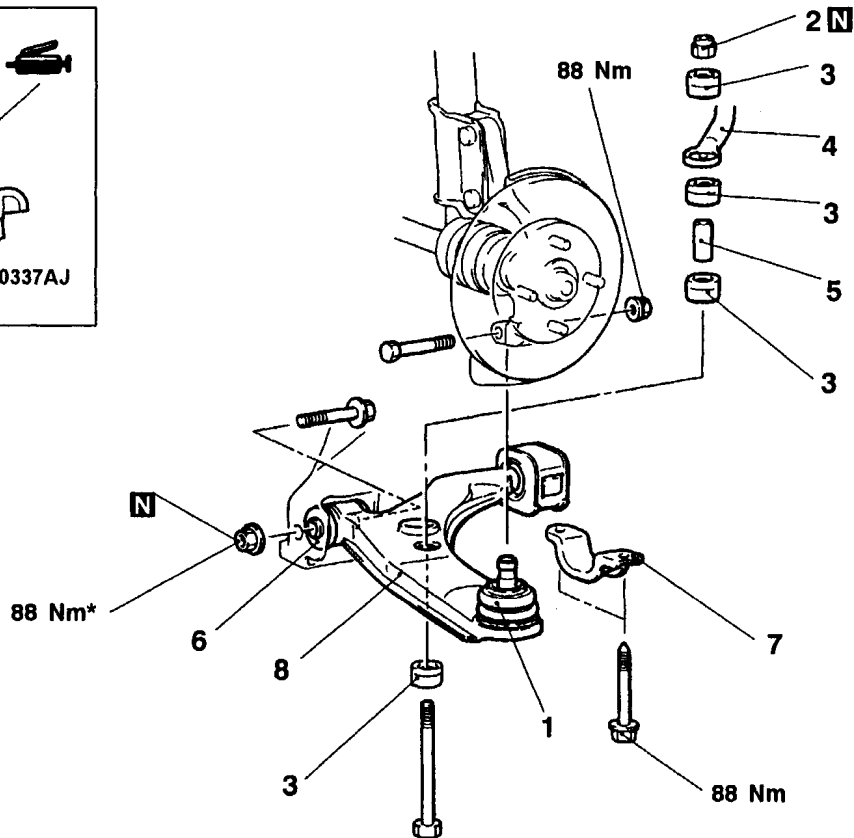
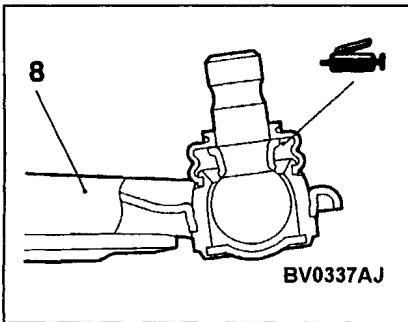

V0103AJ

**Removal steps**

- |  |  |
|--|--|
| <p>▶A◀</p> <ol style="list-style-type: none"> <li>1. Lower arm ball joint connection</li> <li>2. Self-locking nut</li> <li>3. Stabilizer rubber</li> <li>4. Stabilizer bar</li> <li>5. Collar</li> </ol> | <ol style="list-style-type: none"> <li>6. Lower arm front bushing connection</li> <li>7. Support bracket</li> <li>8. Lower arm assembly</li> </ol> |
|--|--|

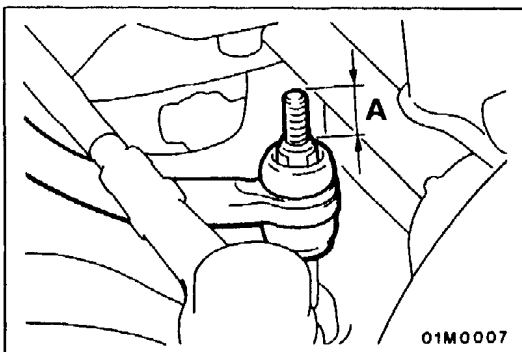

01M0007

**INSTALLATION SERVICE POINT**

▶A◀ **SELF-LOCKING NUT INSTALLATION**

Tighten the self-locking nut so that the amount of protrusion of the end of the stabilizer bar mounting bolt is at the standard value.

**Standard value (A): 22 mm**

**INSPECTION**

- Check the bushing for wear and deterioration.
- Check the lower arm for bend or breakage.
- Check the support bracket for deterioration or damage.
- Check all bolts for condition and straightness.

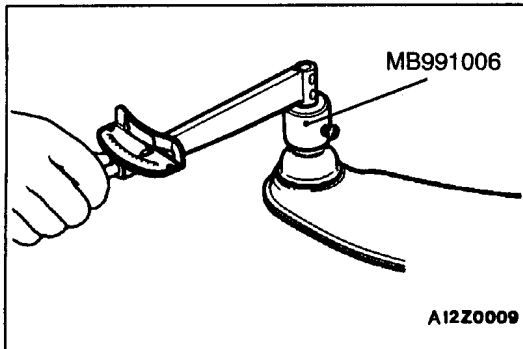
**BALL JOINT STARTING TORQUE/TURNING TORQUE CHECK**

1. After shaking the ball joint stud several times, install the nut to the stud and use the special tool to measure the starting/turning torque of the ball joint.

**Standard value:****Starting torque 1.0 – 5.9 Nm****Turning torque 1.0 – 3.9 Nm**

2. If the measured values exceed the standard values, replace the ball joint.
3. If the measured values are lower than the standard values, check that the ball joint does not feel stiff. If it doesn't feel stiff, it is possible to use the ball joint.

**LOWER ARM BALL JOINT DUST COVER CHECK**

1. Check the dust cover for cracks or damage by pushing it with finger.
2. If the dust cover is cracked or damaged, replace the lower arm assembly.

**NOTE**

Cracks or damage of the dust cover may cause damage of the ball joint.

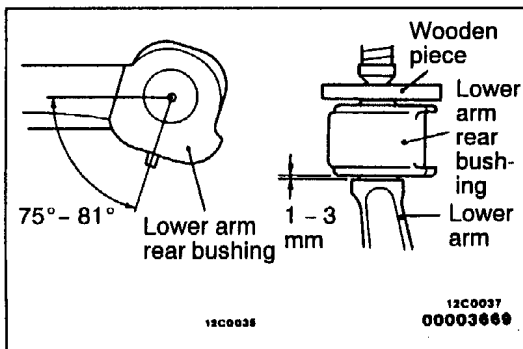
**LOWER ARM REAR BUSHING REPLACEMENT**

1. Apply soapy water between the shaft and old bushing, and pry up bushing using a screwdriver.
2. Apply soapy water to the shaft and new bushing and install new bushing into the shaft at the angle shown in the illustration.
3. Press in the bushing as illustrated.

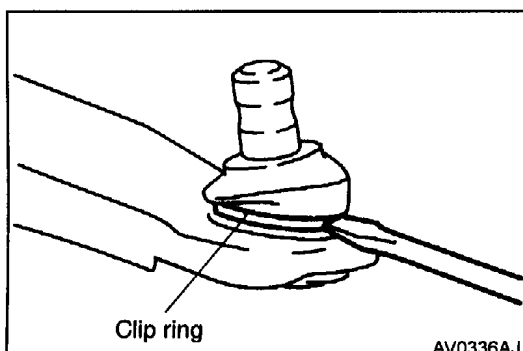
**LOWER ARM BALL JOINT DUST COVER REPLACEMENT**

When the dust cover is damaged or the grease gushes out accidentally during service work, replace the dust cover as follows:

1. Remove the clip ring and the dust cover.
2. Apply multipurpose grease to the inside of the dust cover.
3. Install the dust cover to the ball joint.
4. Secure the dust cover by the clip ring.



5. Check the dust cover for cracks or damage by pushing it with finger.

## STABILIZER BAR

### REMOVAL AND INSTALLATION

**Pre-removal and Post-installation Operation**  
Crossmember Removal and Installation

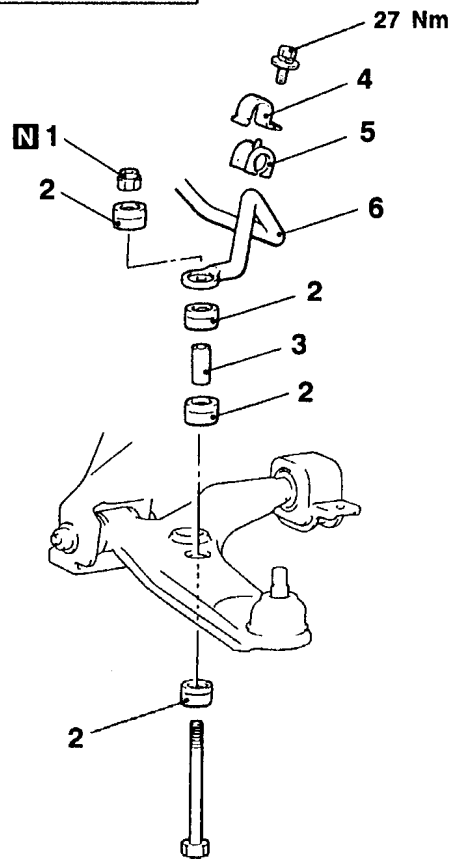

A12M0013

#### Removal steps



1. Self-locking nut
2. Stabilizer rubber
3. Collar



4. Fixture
5. Bushing
6. Stabilizer bar

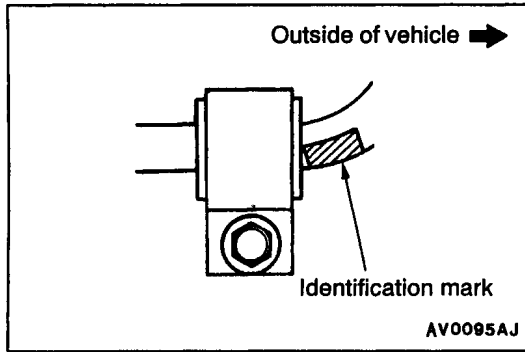

### INSTALLATION SERVICE POINTS

#### ▶A◀ BUSHING/FIXTURE INSTALLATION

Place the identification mark of the stabilizer bar to the right, and install the bushing so that the identification mark is at the shown position.

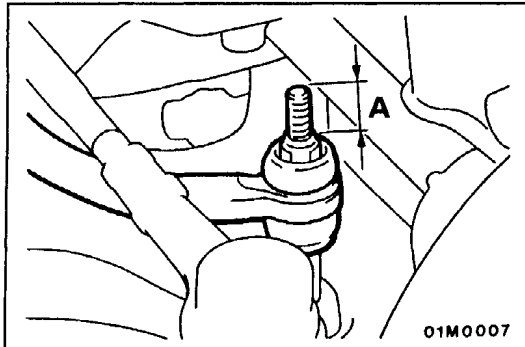

#### ▶B◀ SELF-LOCKING NUT INSTALLATION

Tighten the self-locking nut so that the amount of protrusion of the end of the stabilizer bar mounting bolt is at the standard value.

**Standard value (A): 22 mm**

### INSPECTION

- Check the bushing for wear and deterioration.
- Check the stabilizer bar for deterioration or damage.