

INTERIOR AND SUPPLEMENTAL RESTRAINT SYSTEM (SRS)

CONTENTS

INTERIOR	52A
SUPPLEMENTAL RESTRAINT SYSTEM (SRS)	52B



INTERIOR

CONTENTS

GENERAL	3	SEAT*	12
Outline of Changes	3	Front Seat	12
INSTRUMENT PANEL*	3	Rear Seat	14
FLOOR CONSOLE*	8	SEAT BELT	19
TRIMS <SEDAN>	10	Front Seat Belt	19
		Rear Seat Belt	20

WARNINGS REGARDING SERVICING OF SUPPLEMENTAL RESTRAINT SYSTEM (SRS) EQUIPPED VEHICLES

WARNING!

- (1) Improper service or maintenance of any component of the SRS, or any SRS-related component, can lead to personal injury or death to service personnel (from inadvertent firing of the air bag) or to the driver and passenger (from rendering the SRS inoperative).
- (2) Service or maintenance of any SRS component or SRS-related component must be performed only at an authorized MITSUBISHI dealer.
- (3) MITSUBISHI dealer personnel must thoroughly review this manual, and especially its GROUP 52B – Supplemental Restraint System (SRS) before beginning any service or maintenance of any component of the SRS or any SRS-related component.

NOTE

The SRS includes the following components: SRS-ECU, SRS warning lamp, air bag module, clock spring and interconnecting wiring. Other SRS-related components (that may have to be removed/installed in connection with SRS service or maintenance) are indicated in the table of contents by an asterisk (*).

GENERAL





OUTLINE OF CHANGES

- The service procedure for the instrument panel has been revised due to the change in the front passenger's SRS air bag module.
- The service procedure for the floor console has been revised due to the change in the floor console.
- The service procedure for the trims has been revised due to the change in the trim clips and the trunk rear trim <Sedan>.
- The service procedure for the front seat has been revised due to the change in the seat adjust lever.
- The service procedure for the rear seat has been revised due to the addition in the seat head restraint (centre).
- The service procedures for the front and rear seat belts have been revised due to the change in the seat belt.

INSTRUMENT PANEL

REMOVAL AND INSTALLATION

For installation of the instrument panel, the bolts and screws described below are used. They are indicated by symbols in the illustration.

Name	Symbol	Size mm (D × L)	Colour	Shape
Tapping screw	A	5 × 16	-	 19Z0026
	B	4.8 × 13		
	C	4.8 × 16	Black	
	D	4.2 × 13	-	
	E	2.5 × 9.5		
Machine screw	F	5 × 16	-	 19Z0025
	G	4.8 × 19	-	
Washer assembled bolt	H	6 × 12	-	 19Z0005
Gimlet bolt	I	6 × 16	-	 19Z0012
Flange bolt	J	6 × 14	-	 19Z0024
	K	6 × 14.29		
	L	6 × 16		
	M	5 × 16		

D = Thread diameter
L = Effective thread length

CAUTION: SRS

- (1) When removing and installing the floor console (vehicles equipped with SRS), do not let it bump against the SRS-ECU.
- (2) For the passenger side air bag module removal/installation, always observe the service procedures of GROUP 52B – Air Bag Module and Clock Spring.

Pre-removal and Post-Installation Operation

- Floor Console Assembly Removal and Installation (Refer to P.52A-8.)

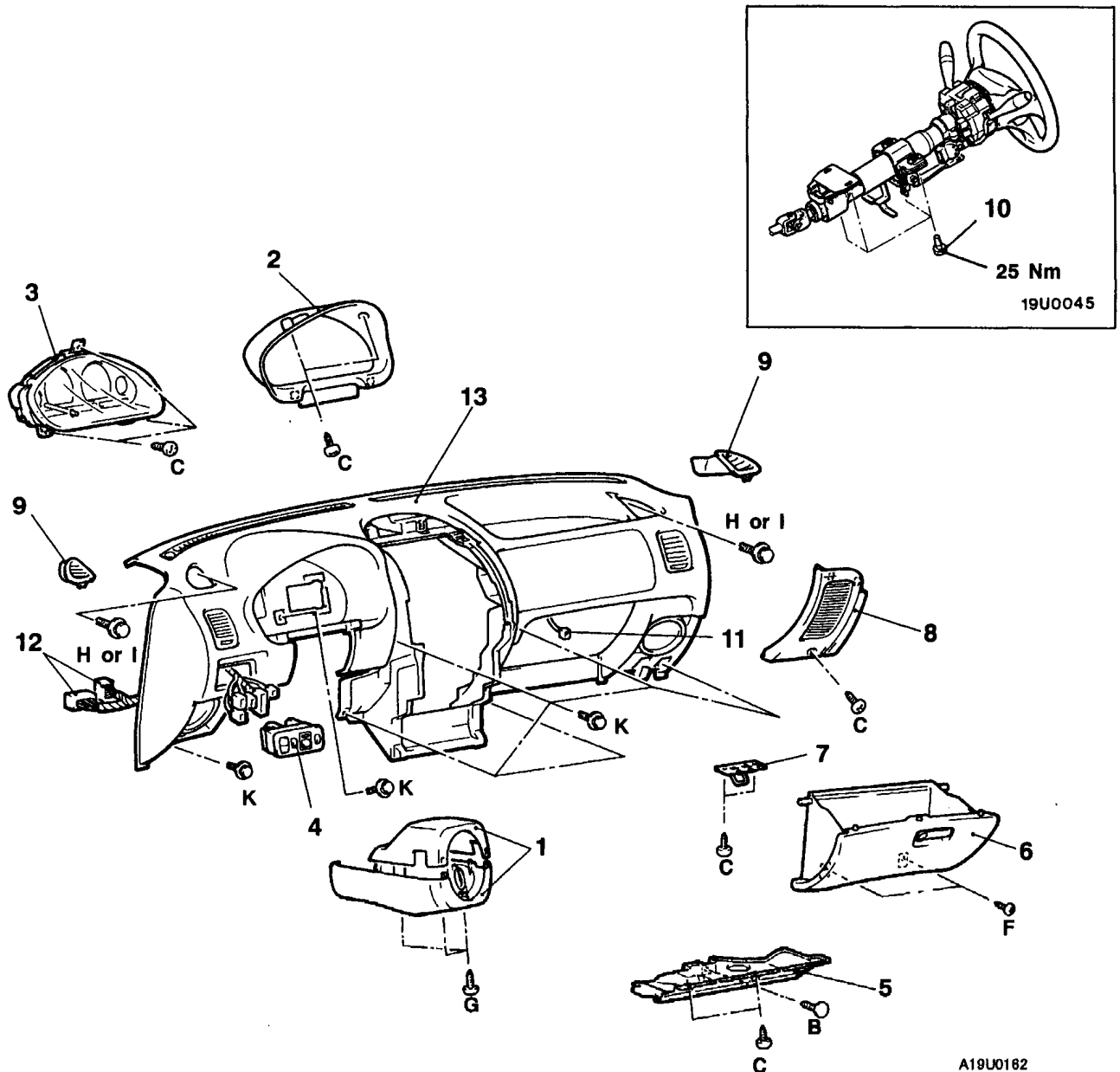
**Removal steps**

1. Column cover
2. Meter bezel
3. Combination meter
4. Instrument panel switch
5. Under cover
6. Glove box
7. Glove box striker
8. Corner panel

9. Side defroster grille
10. Steering column assembly installation bolts
11. Photo sensor connector
12. Harness connector
13. Instrument panel assembly

A19U0162

CLIP AND CLAW POSITIONS

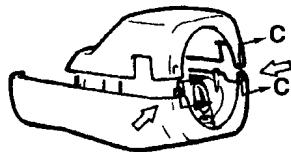
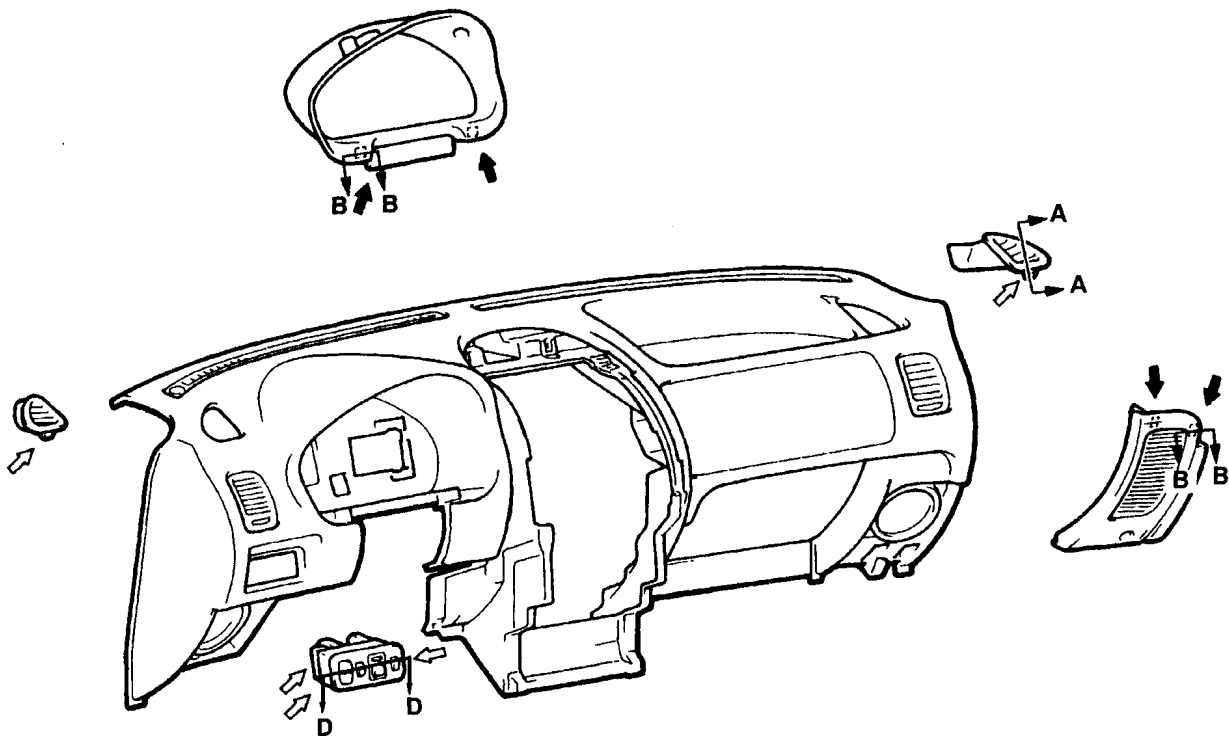

NOTE

- ◄ : Clip positions
- ◁ : Claw positions

AX0024BN

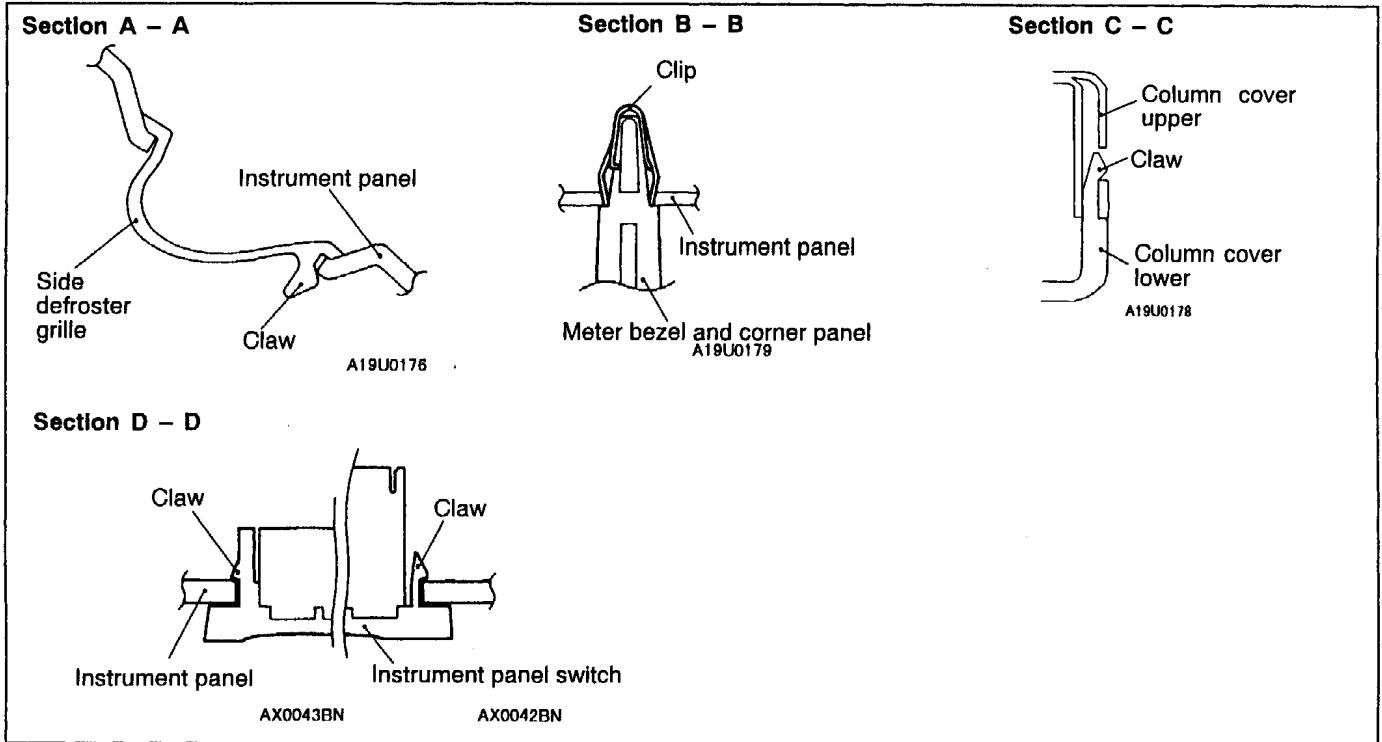

DISASSEMBLY AND REASSEMBLY

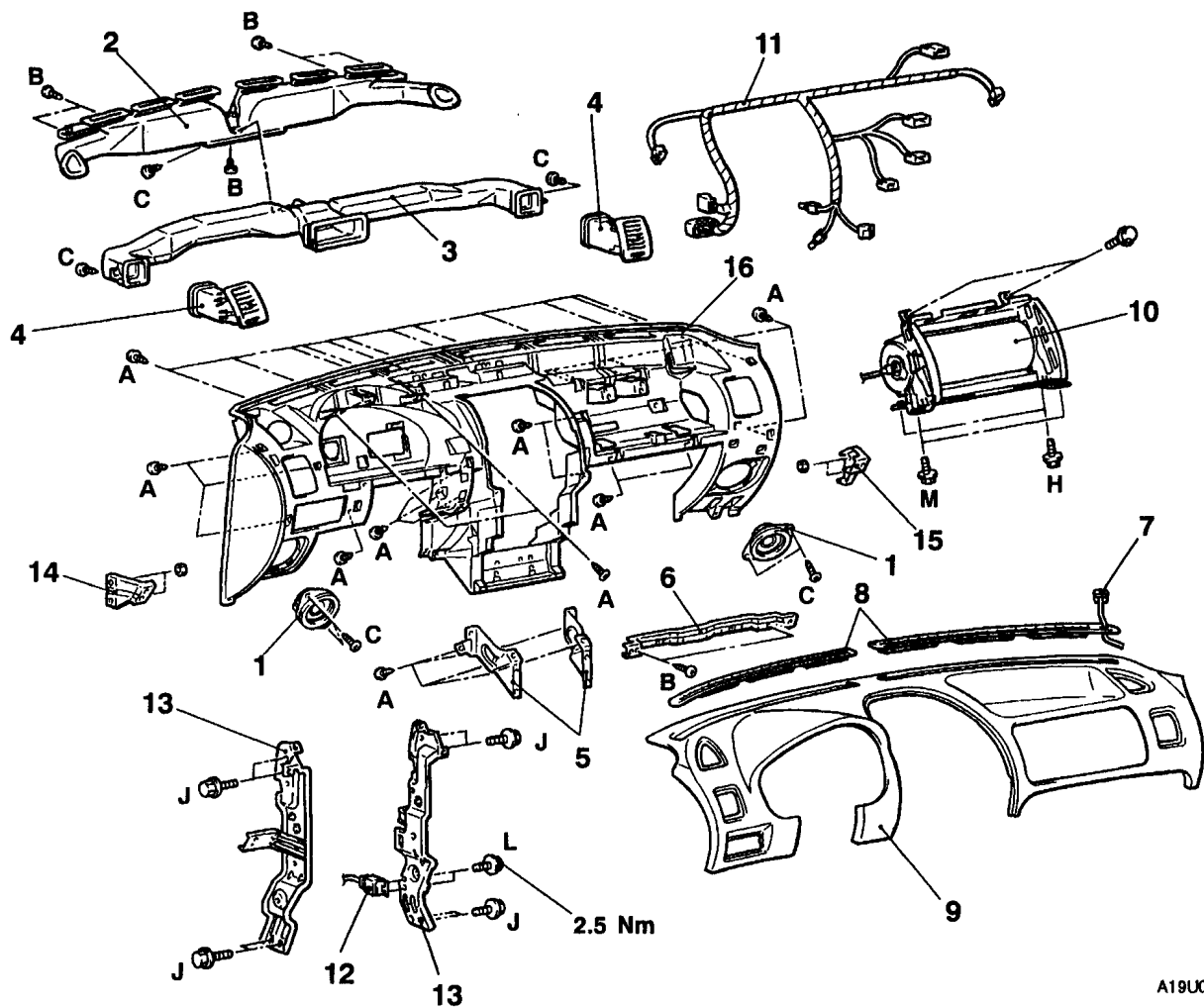

A19U0165

Disassembly steps

- | | |
|---|-------------------------------------|
| 1. Speaker | 11. Instrument panel wiring harness |
| 2. Defroster nozzle assembly | 12. Engine control relay |
| 3. Distribution duct | 13. Center reinforcement |
| 4. Side air outlet assembly | 14. Driver's side lower bracket |
| 5. Instrument panel reinforcement | 15. Passenger's side lower bracket |
| 6. Glove box frame | 16. Instrument panel |
| 7. Photo sensor | |
| 8. Defroster garnish | |
| 9. Instrument pad | |
| 10. Front passenger's air bag module assembly | |

CLAW POSITIONS

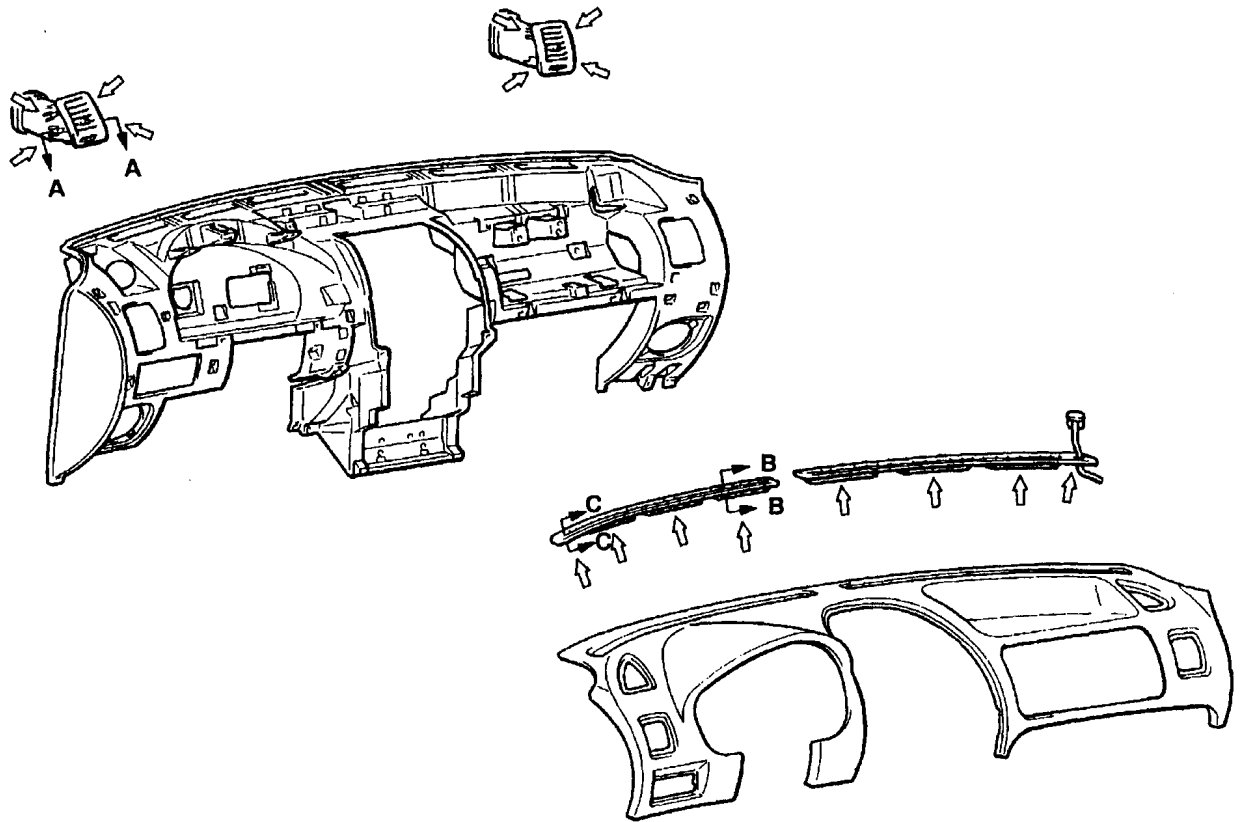

NOTE

↔ : Claw positions

AX0025BN

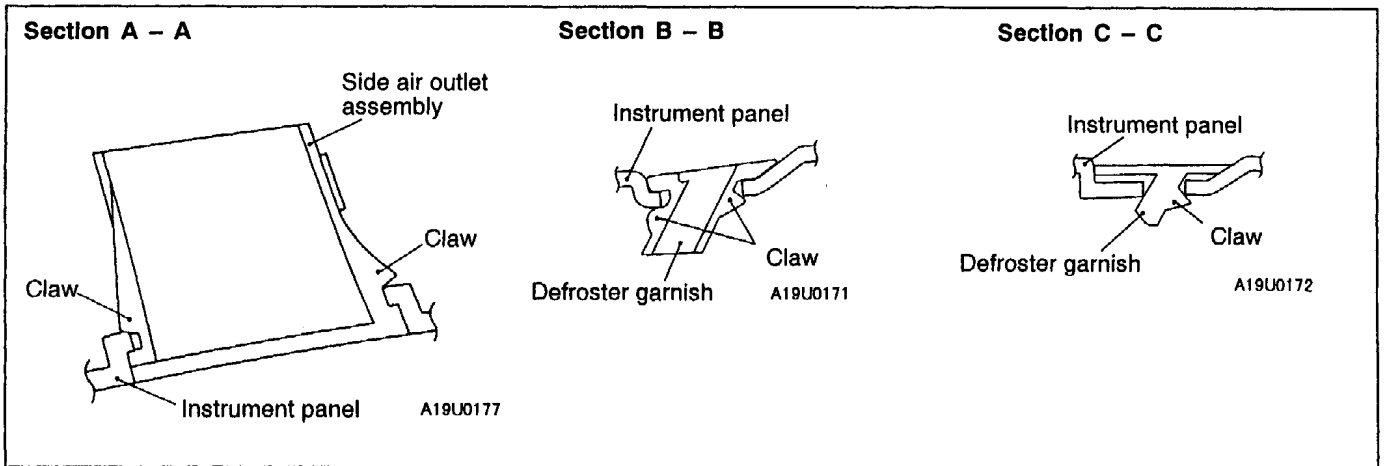

FLOOR CONSOLE

REMOVAL AND INSTALLATION

CAUTION: SRS

When removing and installing the rear floor console assembly from vehicles equipped with SRS, do not let it bump against the SRS-ECU or other components.

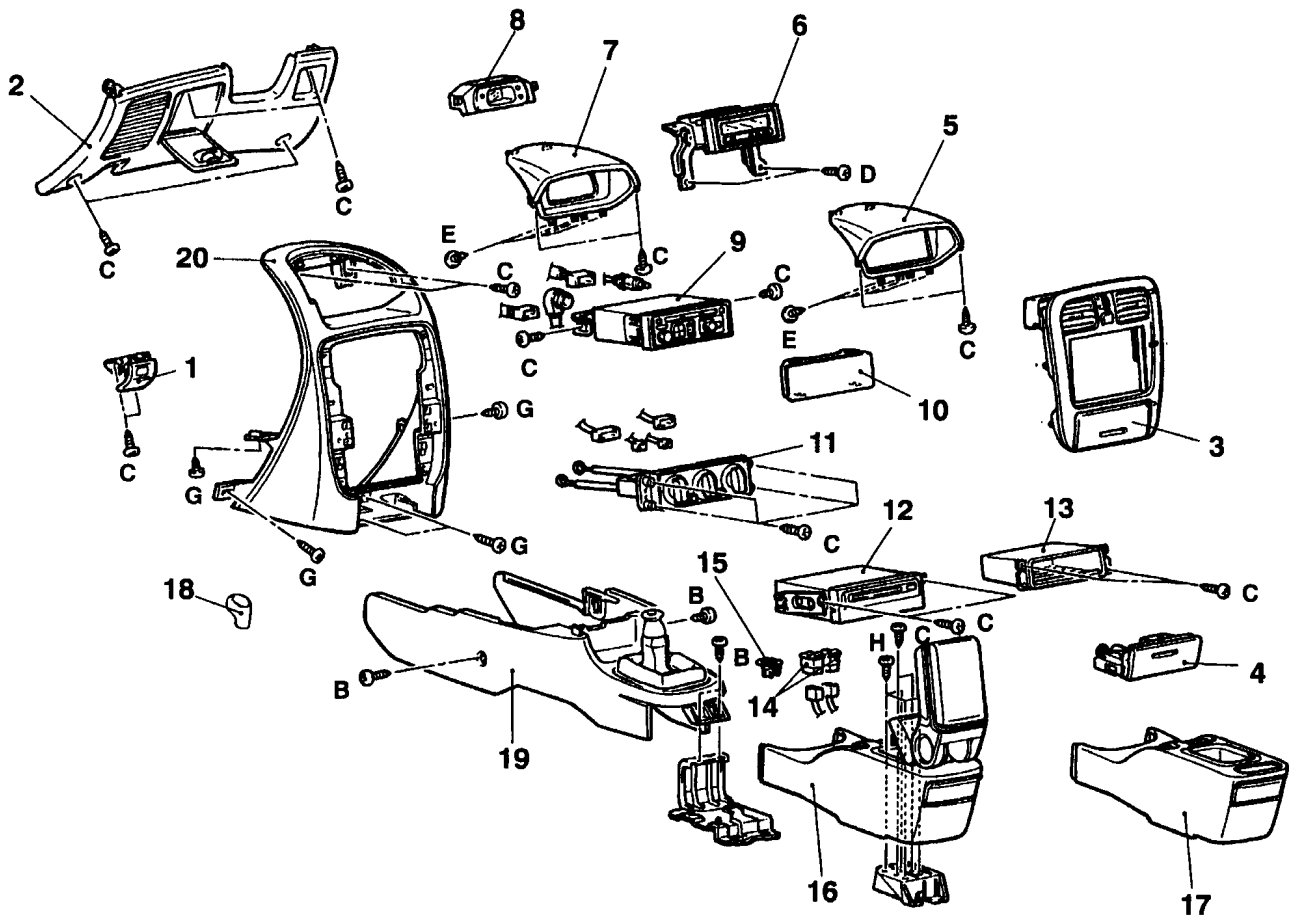

A19U0164

Removal steps

1. Hood lock release handle
2. Instrument under cover
3. Center panel assembly
4. Ashtray
5. Hood display (display)
6. Display unit
7. Hood display (clock)
8. Clock
9. Radio and tape player
10. Radio plug
11. Heater control assembly
12. Navigation unit
13. Box
14. Switch
15. Coin plug
16. Rear floor console assembly (with centre armrest)
17. Rear floor console assembly (without centre armrest)
18. Shift lever knob <M/T> (Refer to GROUP 22.)
19. Front floor console assembly
20. Center console assembly

CLIP AND CLAW POSITIONS

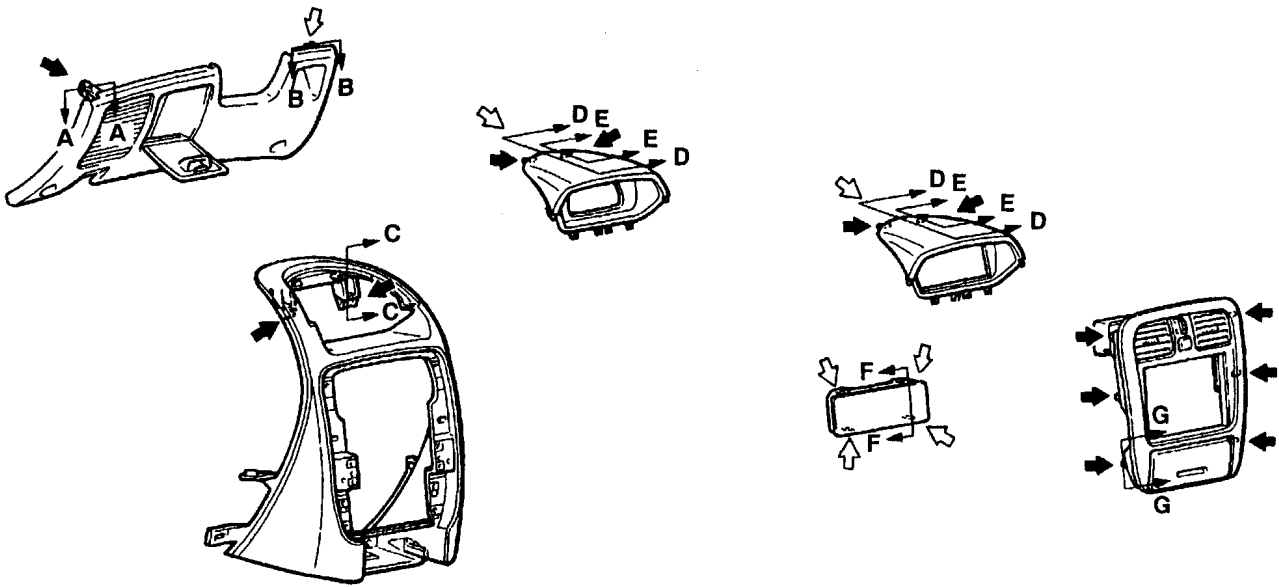

NOTE

- ← : Clip positions
- ⇨ : Claw positions

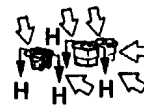

AX0033BN

<p>Section A – A</p> <p>Clip</p> <p>Instrument panel</p> <p>Instrument under cover A19U0179</p>	<p>Section B – B</p> <p>Claw</p> <p>Instrument panel</p> <p>Instrument under cover AX0053BN</p>	<p>Section C – C</p> <p>Centre console</p> <p>Clip</p> <p>Instrument panel C19U0179</p>	<p>Section D – D</p> <p>Hood display</p> <p>Instrument panel</p> <p>Clip A19U0173</p>
<p>Section E – E</p> <p>Hood display</p> <p>Claw</p> <p>Instrument panel A19U0174</p>	<p>Section F – F</p> <p>Instrument panel</p> <p>Claw</p> <p>Radio plug AX0026BN</p>	<p>Section G – G</p> <p>Clip</p> <p>Centre panel assembly</p> <p>Instrument panel B19U0179</p>	<p>Section H – H</p> <p>Coin plug or switch</p> <p>Floor console</p> <p>Claw</p> <p>Claw AX0023BN</p>

TRIMS <SEDAN>

REMOVAL AND INSTALLATION

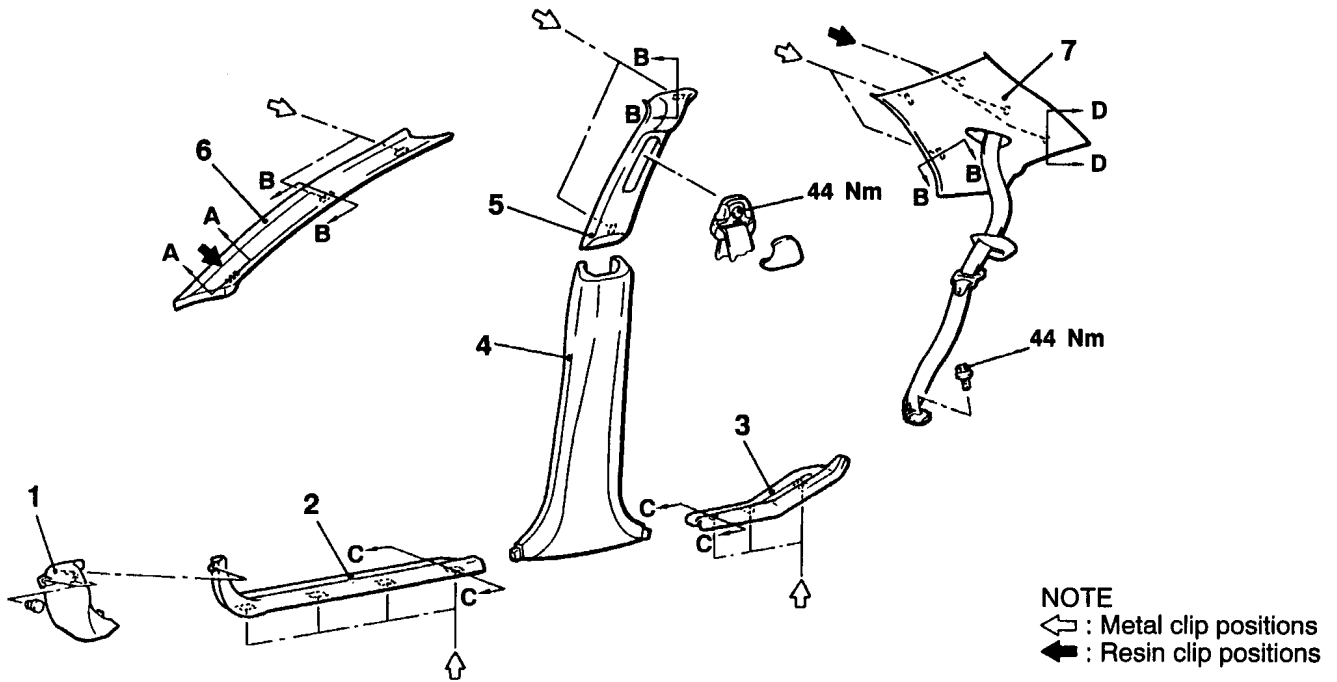

NOTE
 ↖ : Metal clip positions
 ↗ : Resin clip positions

19U0097

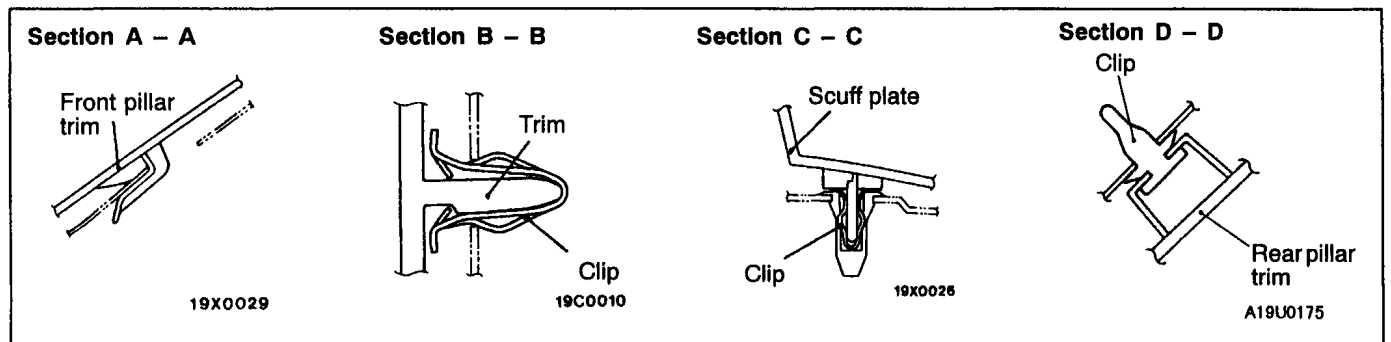

- 1. Cowl side trim
- 2. Front scuff plate
- 3. Rear scuff plate
- 4. Center pillar lower trim

- 5. Center pillar upper trim
- 6. Front pillar trim
- 7. Rear pillar trim

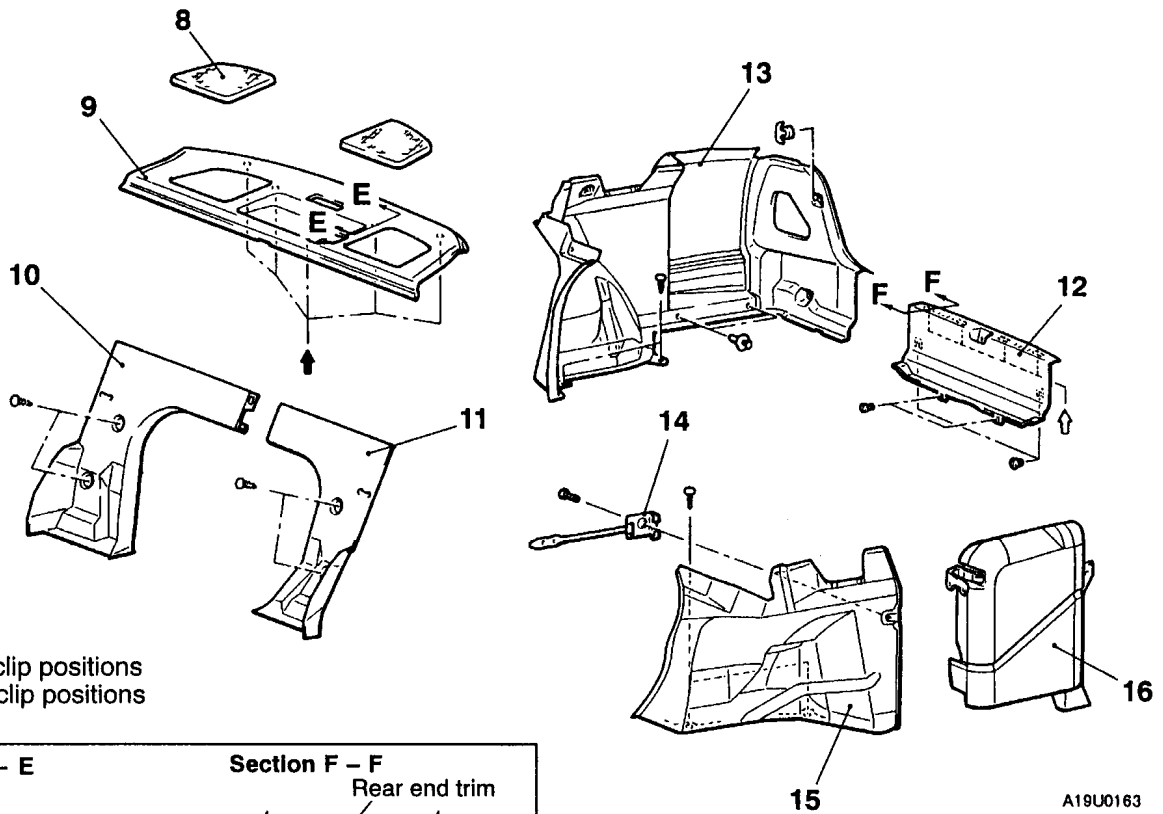

NOTE

- ➡ : Metal clip positions
- ↔ : Resin clip positions

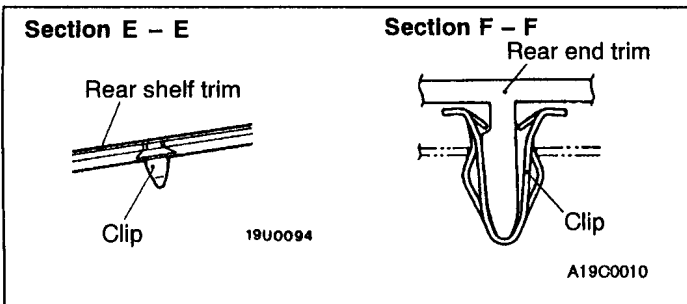

- 8. Rear speaker garnish
- 9. Rear shelf trim
- 10. Shelf front cover (RH) or trunk front trim
- 11. Shelf front cover (LH)

- 12. Rear end trim
- 13. Trunk side trim (RH)
- 14. Hook assembly
- 15. Trunk side trim (LH)
- 16. Trunk box

A19U0163

SEAT

FRONT SEAT

REMOVAL AND INSTALLATION

Pre-removal and Post-Installation Operation

- Rear Floor Console Assembly Removal and Installation (Refer to P.52A-8).
- Before removal of the seat equipped with the side air bag module, refer to GROUP 52B – SRS Service Precautions and Air Bag Module.

CAUTION: SRS

When removing and installing the rear floor console (vehicles equipped with SRS), do not let it bump against the SRS-ECU.

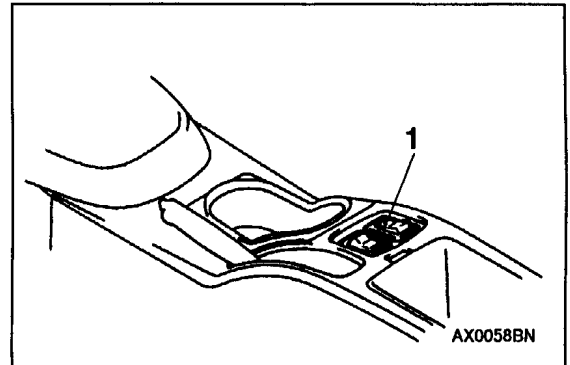
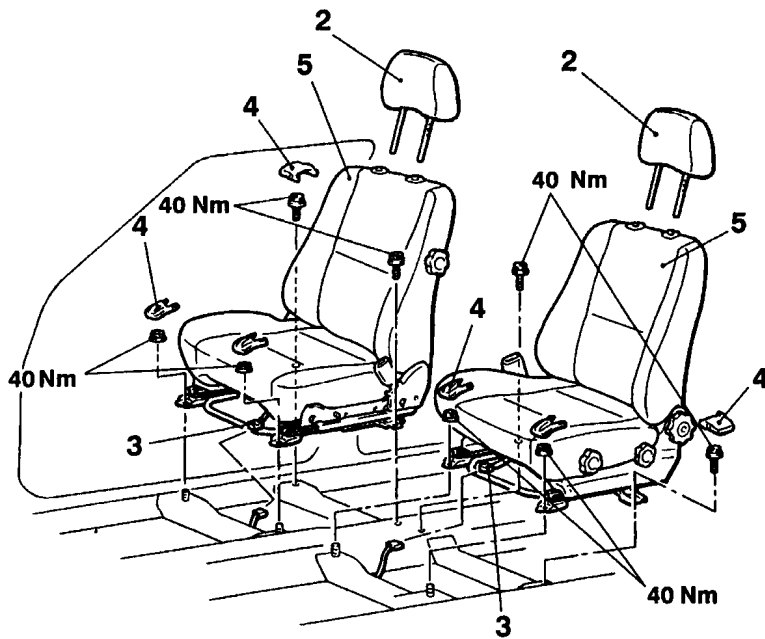

NOTE

After provisionally tightening the seat assembly mounting nuts and bolts in every installation location, fully tighten them to the specified torque.

AX0072BN

1. Heated seat switch
<vehicles with heated seat>
2. Headrest

Front seat assembly removal steps

3. Harness connector
<vehicles with heated seat>
4. Seat anchor cover
- ▶◀ 5. Front seat assembly

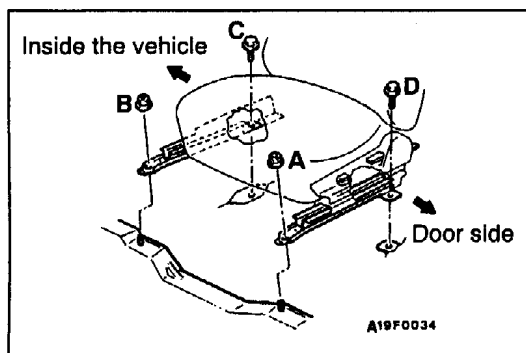

INSTALLATION SERVICE POINT

▶◀ FRONT SEAT ASSEMBLY INSTALLATION

Tighten the front seat mounting bolts in the order A, B, C, and D.

DISASSEMBLY AND REASSEMBLY

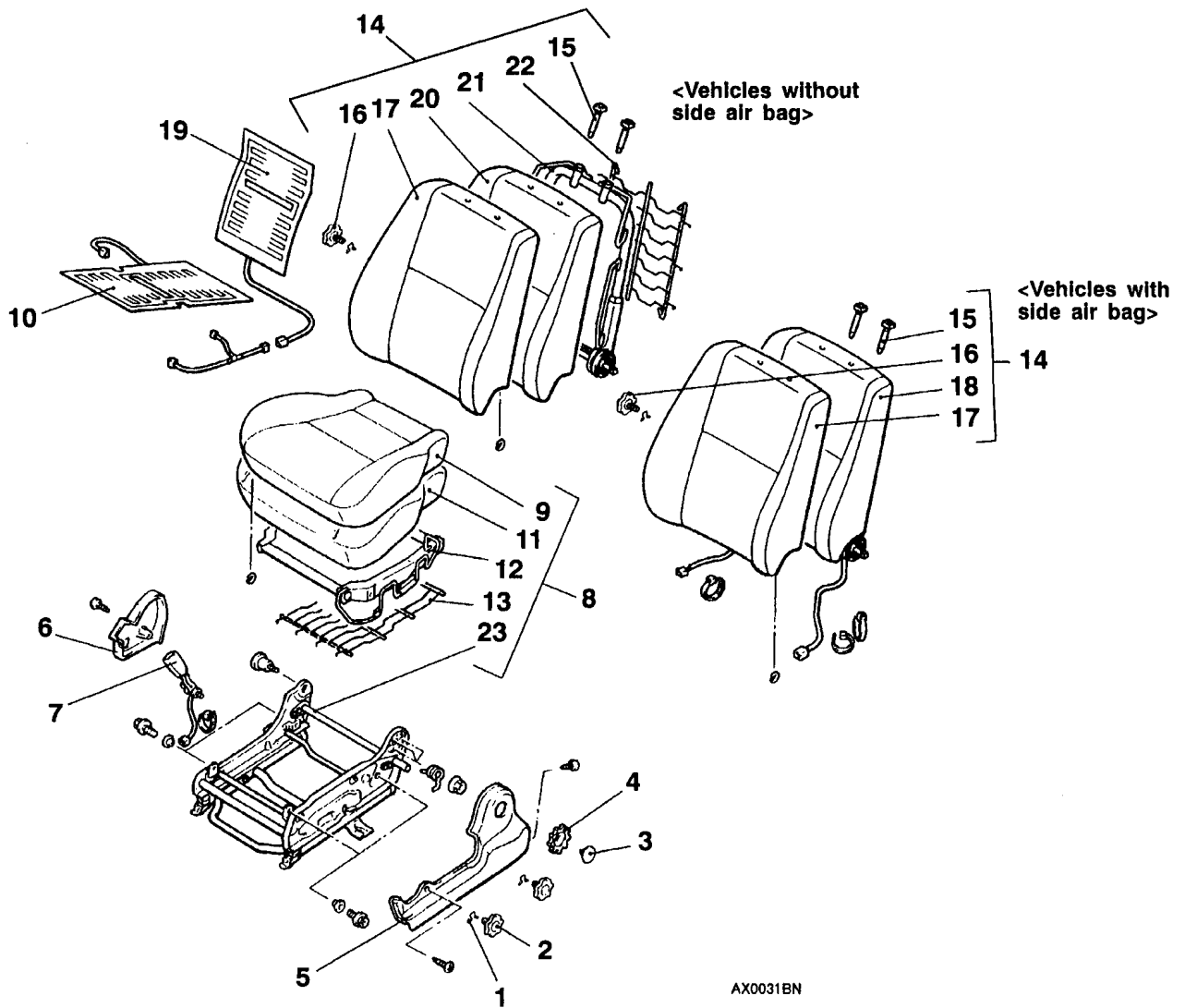

Seat disassembly steps

1. Shaft snap ring
2. Height adjust knob
3. Cap
4. Reclining knob
5. Front seat side shield cover
6. Front seat hinge cover
7. Inner seat belt
8. Front seat cushion assembly
9. Front seat cushion cover
10. Front seat heater cushion
11. Front seat cushion pad
12. Front seat cushion frame



13. Suspension cushion
14. Front seatback assembly
15. Headrest guide
16. Lumbar support knob
17. Front seatback cover
18. Front seatback pad and frame assembly
19. Front seat heater back
20. Front seatback pad
21. Front seatback frame
22. Suspension back
23. Seat adjuster assembly

AX0031BN

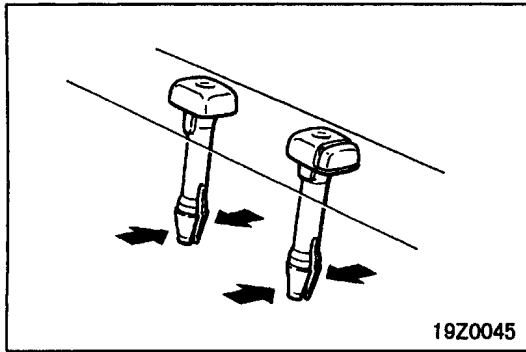

REMOVAL SERVICE POINT

◀A▶ HEADRESTRAINT GUIDE REMOVAL

Compress the indicated portions of the guides to remove them.

**REAR SEAT
REMOVAL AND INSTALLATION**

<Sedan>

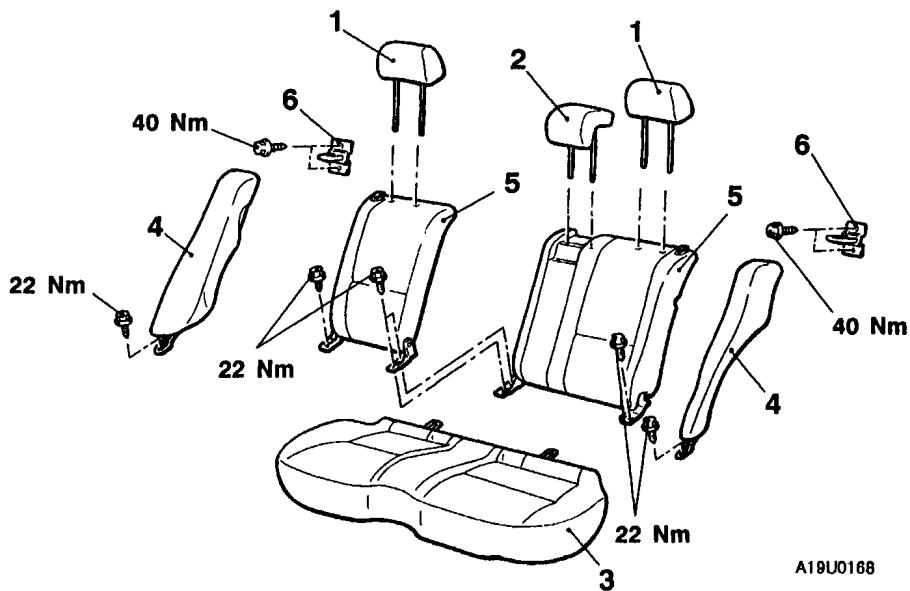

Removal steps

- 1. Headrest (side)
- 2. Headrest (centre)
- 3. Seat cushion

◀A▶ ▶B▶

- ▶A▶ 4. Side seatback assembly
- ▶A▶ 5. Rear seatback assembly
- 6. Rear seat striker

<Hatchback>

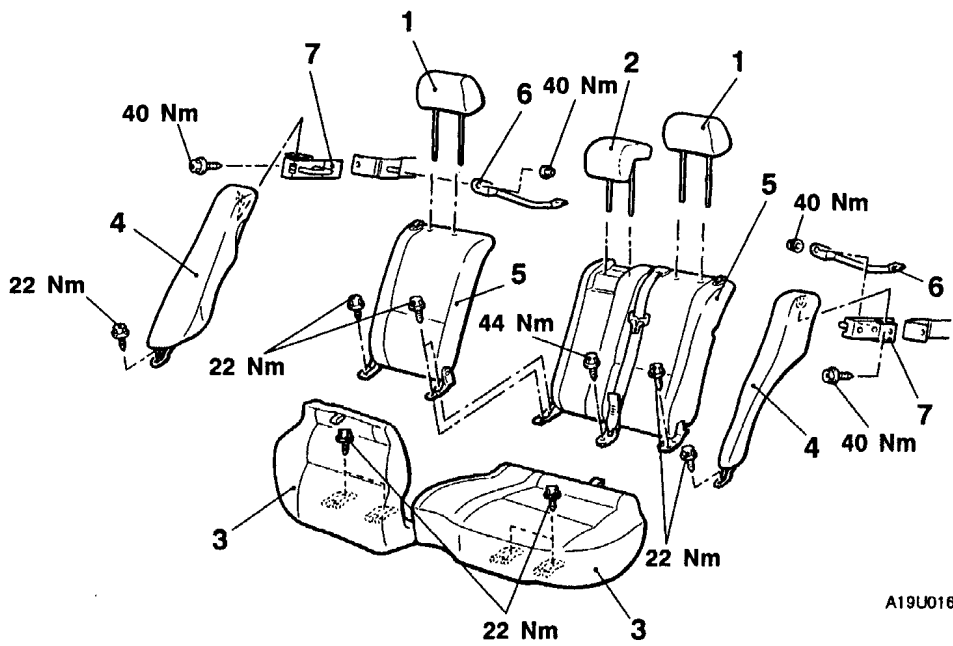

Removal steps

- | | |
|--|--|
| <ol style="list-style-type: none"> 1. Headrest (side) 2. Headrest (centre) 3. Seat cushion 4. Side seatback assembly | <ol style="list-style-type: none"> 5. Rear seatback assembly 6. Rear seat stabilizer 7. Rear seat striker |
|--|--|

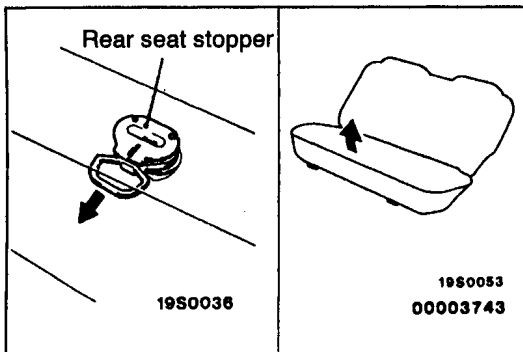
**REMOVAL SERVICE POINT****◀A▶ SEAT CUSHION REMOVAL**

While keeping the rear seat stopper pulled, lift up the seat cushion to remove it.

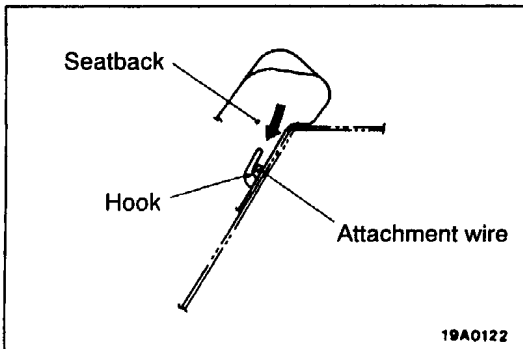
**INSTALLATION SERVICE POINTS****▶A◀ REAR SEATBACK ASSEMBLY/SIDE SEATBACK ASSEMBLY INSTALLATION**

Push the rear seatback assembly or side seatback assembly in the direction indicated in the illustration; then securely attach the attachment wire to the body side hook and install the rear seatback assembly or side seatback assembly.

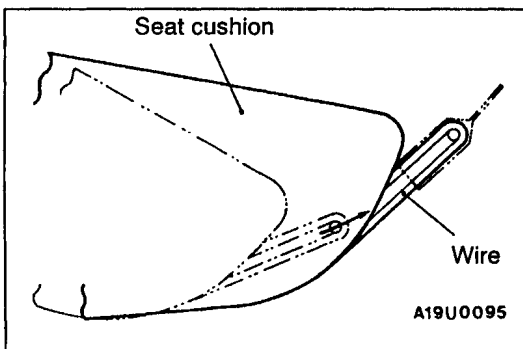
**▶B◀ SEAT CUSHION INSTALLATION**

Insert the wire of the seat cushion into the body hole to install the seat cushion.

DISASSEMBLY AND REASSEMBLY

<Sedan>

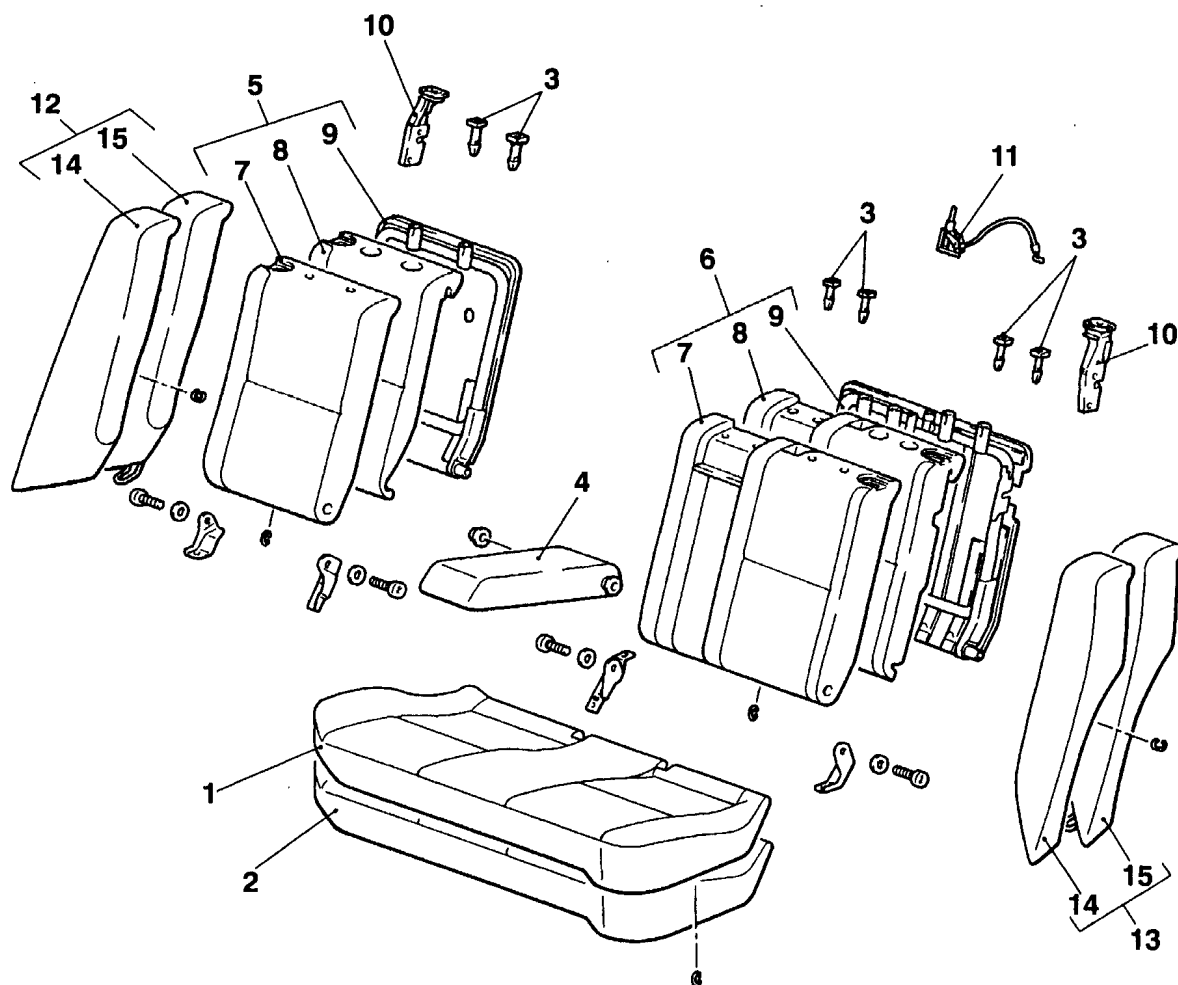

AX0074BN

Seat disassembly steps



- | | |
|----------------------------------|--|
| 1. Seat cushion cover | 10. Lock assembly |
| 2. Seat cushion pad | 11. Centre lock assembly |
| 3. Headrest guide | 12. Rear side seatback assembly (R.H.) |
| 4. Armrest | 13. Rear side seatback assembly (L.H.) |
| 5. Rear seatback assembly (R.H.) | 14. Rear side seatback cover |
| 6. Rear seatback assembly (L.H.) | 15. Rear side seatback pad |
| 7. Rear seatback cover | |
| 8. Rear seatback pad | |
| 9. Rear seatback frame | |

<Hatchback>

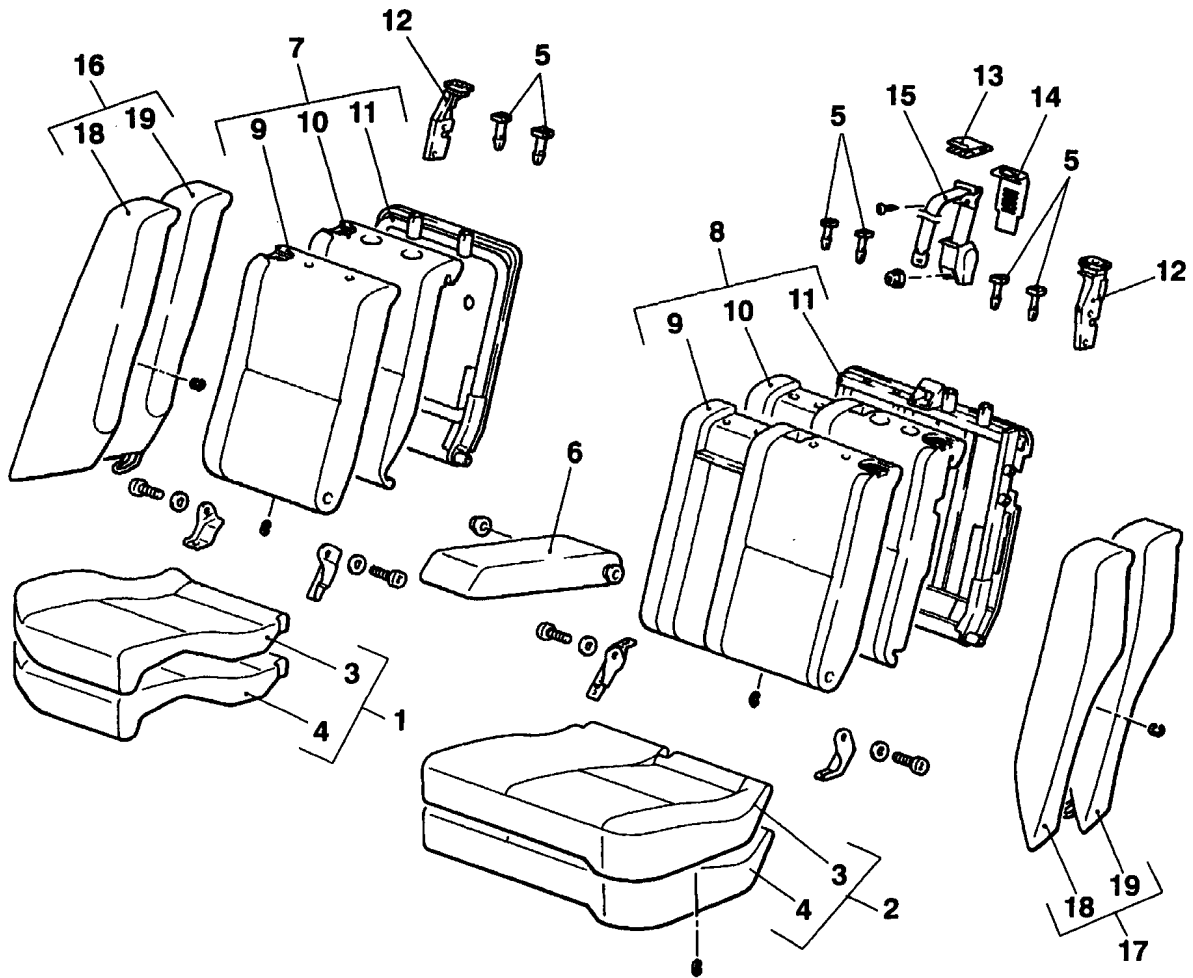

AX0073BN

Seat disassembly steps

- | | |
|---|--|
| <ol style="list-style-type: none"> 1. Rear seat cushion assembly (R.H.) 2. Rear seat cushion assembly (L.H.) 3. Rear seat cushion cover 4. Rear seat cushion pad 5. Headrest guide 6. Armrest 7. Rear seatback assembly (R.H.) 8. Rear seatback assembly (L.H.) 9. Rear seatback cover 10. Rear seatback pad 11. Rear seatback frame | <ol style="list-style-type: none"> 12. Lock assembly 13. Centre seat belt garnish 14. Centre seat belt garnish plate 15. Centre seat belt assembly 16. Rear side seatback assembly (R.H.) 17. Rear side seatback assembly (L.H.) 18. Rear side seatback cover 19. Rear side seatback pad |
|---|--|



REMOVAL SERVICE POINT

◀A▶ HEADRESTRAINT GUIDE REMOVAL

Compress the indicated portions of the guides to remove them.

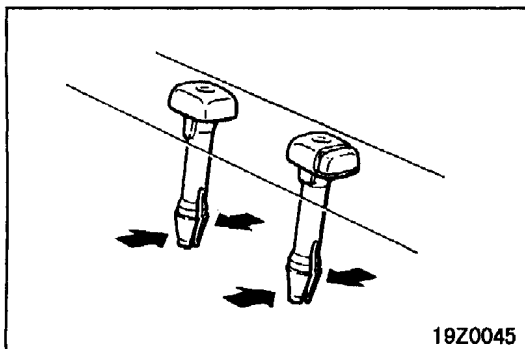

19Z0045

SEAT BELT

For removal and installation procedures for the seat belt with pre-tensioner, refer to '96 CARISMA Workshop Manual (Pub. No. PWDE9502).

FRONT SEAT BELT REMOVAL AND INSTALLATION

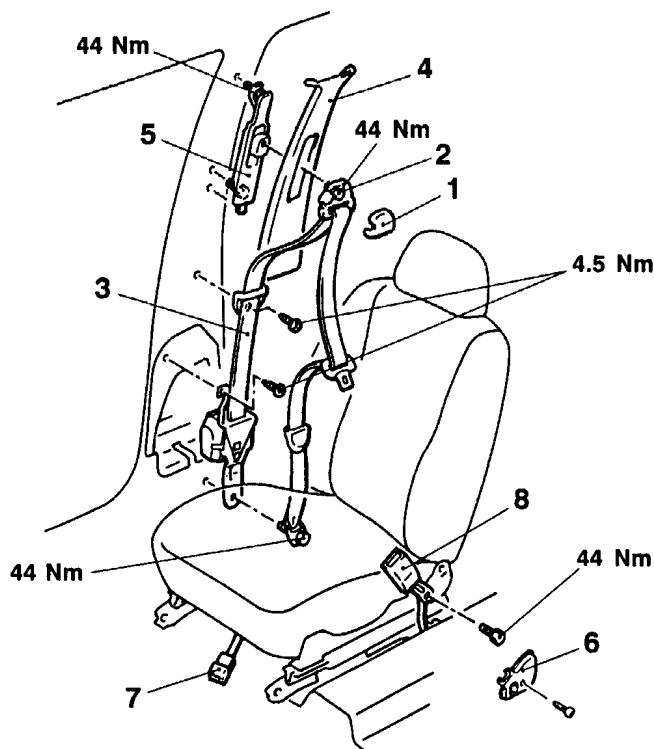

A19U0170

Outer seat belt removal steps

- Front scuff plate and rear scuff plate (Refer to P.52A-10.)
- Center pillar lower trim (Refer to P.52A-10.)
- 1. Sash guide cover
- 2. Sash guide
- 3. Outer seat belt
- 4. Center pillar upper trim (Refer to P.52A-10.)
- 5. Adjustable seat belt anchor

Inner seat belt removal steps

- Front seat assembly (Refer to P.52A-12.)
- 6. Front seat hinge cover
- 7. Buckle harness
- 8. Inner seat belt

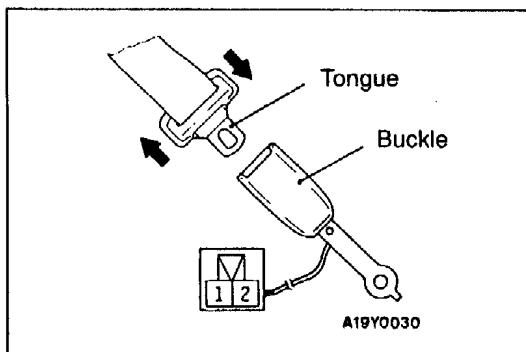

INSPECTION

SEAT BELT SWITCH CONTINUITY CHECK

Items	Terminal No.	
	1	2
Fastened seat belt		
Unfastened seat belt	○————○	○————○

REAR SEAT BELT REMOVAL AND INSTALLATION

<Sedan>

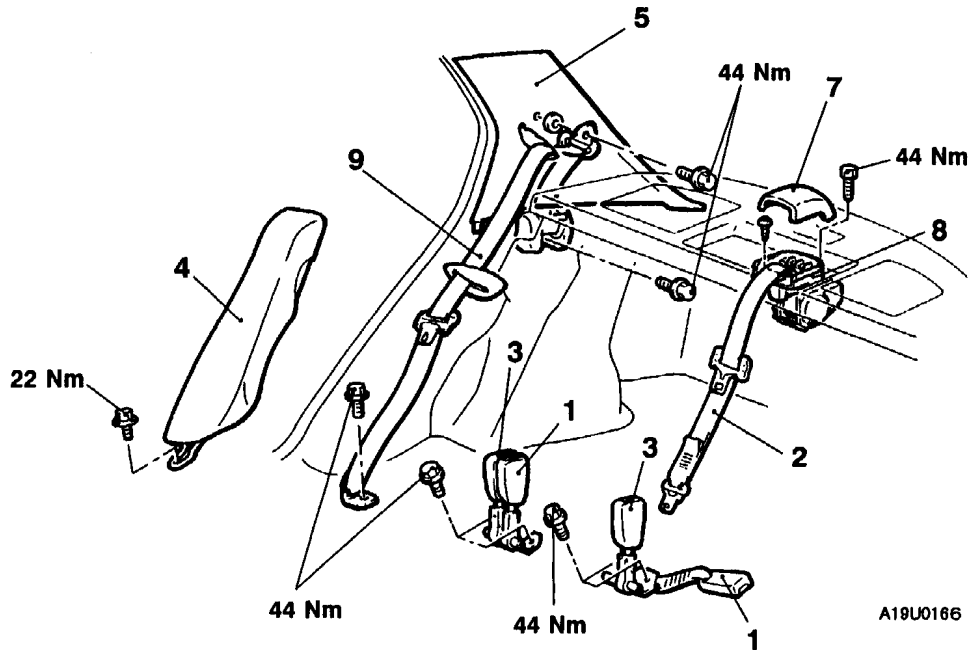

<Hatchback>

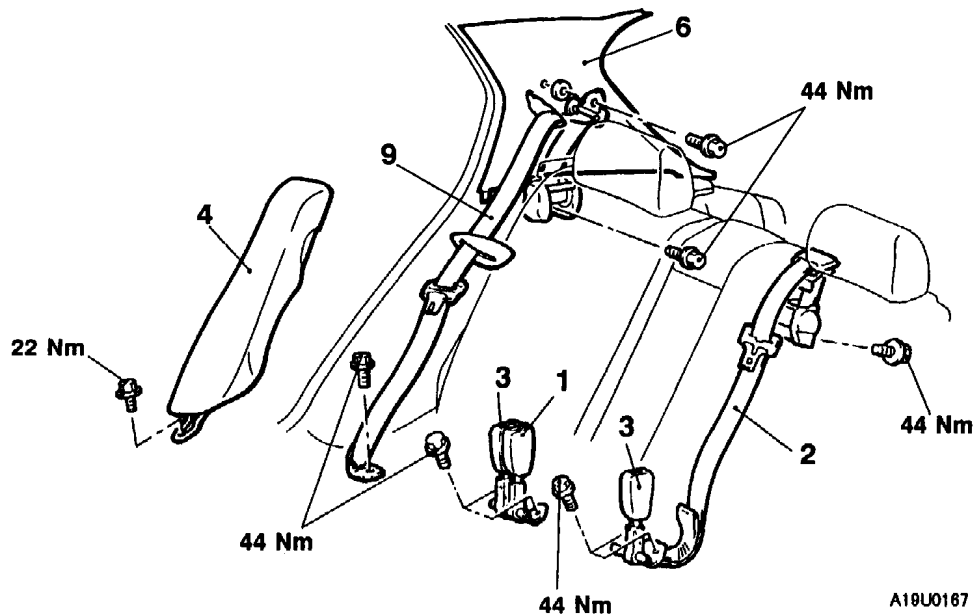

Removal steps

- Rear seat cushion
(Refer to P.52A-14.)
- 1. Inner seat belt
(Center seat belt)
- 2. Outer seat belt
(Center seat belt)
- 3. Inner seat belt
- 4. Side seatback assembly
(Refer to P.52A-14.)
- 5. Rear pillar trim <Sedan>
(Refer to P.52A-10.)
- 6. Rear pillar trim <Hatchback>
(Refer to '96 CARISMA Basic
Manual Pub. No. PWDE9502.)
- 7. Cover <Sedan>
- 8. Webbing guide <Sedan>
- 9. Outer seat belt

SUPPLEMENTAL RESTRAINT SYSTEM (SRS)

CONTENTS

GENERAL	2	AIR BAG MODULES AND CLOCK SPRING	6
Outline of Changes	2	SIDE IMPACT SENSOR	10
SRS SERVICE PRECAUTIONS	2		
TROUBLESHOOTING	3		

CAUTION

- Carefully read and observe the information in the SERVICE PRECAUTIONS (P.52B-3.) prior to any service.
 - For information concerning troubleshooting or maintenance, always observe the procedures in the Troubleshooting (P.52B-5.) section.
 - If any SRS components are removed or replaced in connection with any service procedures, be sure to follow the procedures in the INDIVIDUAL COMPONENT SERVICE section (P.52B-18.) for the components involved.
 - If you have any questions about the SRS, please contact your local distributor.
-

GENERAL

OUTLINE OF CHANGES

- The SRS service precautions have been revised due to the change in the SRS-ECU connector.
- The troubleshooting has been revised due to the change in the SRS-ECU connector, the side impact sensor and the SRS warning lamp.
- The service procedures have been revised due to the change in the front passenger's air bag module and the clock spring connector.
- The service procedure has been revised due to the change in the side impact sensor.

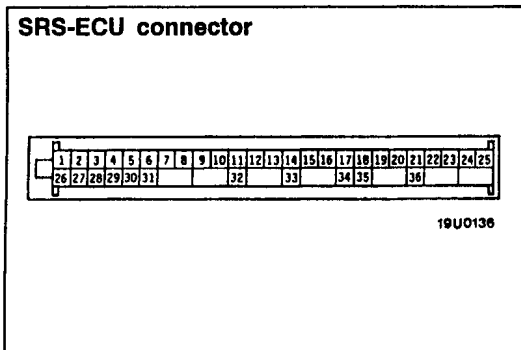

SRS SERVICE PRECAUTIONS

1. Do not attempt to repair the wiring harness connectors of the SRS. If any of the connectors are diagnosed as faulty, replace the wiring harness. If the wires are diagnosed as faulty, replace or repair the wiring harness according to the following table.

SRS-ECU Terminal No.	Destination of harness	Corrective action
1 to 4	–	–
5, 14	Body wiring harness → Side impact sensor (R.H.)	Correct or replace each wiring harness.
6, 34	Body wiring harness → Side impact sensor (L.H.)	
7, 8	Body wiring harness → Side air bag module (R.H.)	
9, 10	Body wiring harness → Side air bag module (L.H.)	
11	–	–
12, 13	Body wiring harness → Air bag module (Front passenger's side)	Correct or replace each wiring harness.
15, 16	Body wiring harness → Clock spring → Air bag module (Driver's side)	Correct or replace the dash wiring harness. Replace the clock spring.
17	Body wiring harness → Diagnosis connector	Correct or replace each wiring harness.
18	Body wiring harness → Junction block (fuse No.4)	
19	Body wiring harness → Combination meter (SRS warning lamp)	
20	Body wiring harness → Earth	
21	Body wiring harness → Junction block (fuse No.11)	
22, 23	Body wiring harness → Seat belt with pre-tensioner (Front passenger's side)	
24, 25	Body wiring harness → Seat belt with pre-tensioner (Driver's side)	
26 to 33, 35, 36	–	–

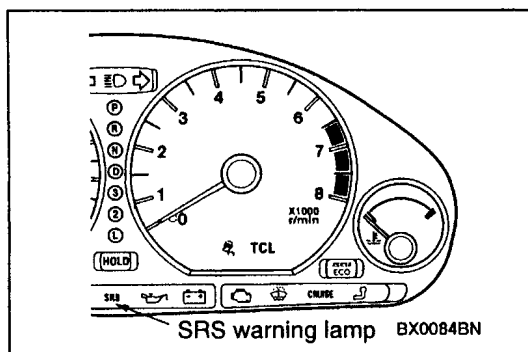

TROUBLESHOOTING

SRS WARNING LAMP CHECK

Turn the ignition with the key ON position. Does the SRS warning lamp illuminate for about 7 seconds, turn OFF and then remain extinguished for at least 5 seconds? If yes, SRS system is functioning properly. If no, consult page 52B-3.

Caution

The SRS warning lamp bulb should be 0.84 W. If other bulb than the specified rating is used, the SRS warning lamp bulb will be burned out.

INSPECTION CHART FOR DIAGNOSIS CODES

Inspect according to the inspection chart that is appropriate for the malfunction code.

Code No.	Diagnosis Item	Reference page	
14	Analog G-sensor system in the SRS-ECU	*2	
15, 16	Front impact safing G sensor system inside SRS-ECU	*2	
17	Side impact safing G sensor system inside SRS-ECU	*3	
21, 22, 61, 62	Driver's side air bag module (squib) system	*3	
24, 25, 64, 65	Front passenger's side air bag module (squib) system	*3	
26, 27	Driver's side pre-tensioner (squib) system	*2	
28, 29	Front passenger's side pre-tensioner (squib) system	*2	
31, 32	SRS-ECU capacitor system	*2	
35	SRS-ECU (deployed air bag) system	*2	
41*1	IG ₁ (A) power circuit system	*3	
42*1	IG ₁ (B) power circuit system	*3	
43	SRS warning lamp drive circuit system	Lamp does not illuminate.*1	*3
		Lamp does not switch off.	*3
44	SRS warning lamp drive circuit system	*2	
45	Internal circuit system of non-volatile memory (EEPROM) inside SRS-ECU	*2	
51, 52	Driver's side air bag module (squib ignition drive circuit) system	*2	
54, 55	Front passenger's side air bag module (squib ignition drive circuit) system	*2	

Code No.	Diagnosis Item	Reference page
56, 57	Driver's side pre-tensioner (squib ignition drive circuit) system	*2
58, 59	Passenger's side pre-tensioner (squib ignition drive circuit) system	*2
66, 67	Driver's side pre-tensioner (squib) system	*3
68, 69	Front passenger's side pre-tensioner (squib) system	*3
71, 72, 75, 76	Side air bag module (L.H.) (squib) system	*3
73, 74	Side air bag module (L.H.) (squib) ignition drive circuit system	*3
81, 82, 85, 86	Side air bag module (R.H.) (squib) system	*3
83, 84	Side air bag module (R.H.) (squib) ignition drive circuit system	*3
91*1	Side impact sensor (L.H.) power supply circuit system	52B-4
92	Side impact sensor (L.H.) system	*3
93	Side impact sensor (L.H.) communication system	*3
94*1	Side impact sensor (R.H.) power supply circuit system	*3
95	Side impact sensor (R.H.) system	*3
96	Side impact sensor (R.H.) communication system	*3

NOTE

- (1) *1: If the vehicle condition returns to normal, the diagnosis code will be automatically erased, and the SRS warning lamp will return to normal.
- (2) *2: Refer to '96 CARISMA Basic Manual (Pub. No. PWDE9502).
- (3) *3: Refer to '98 CARISMA (except GDI) Workshop Manual (Pub. No. PWDE9502-B).
- (4) If the vehicle has a discharged battery it will store the fault codes 41 or 42. When these diagnosis codes are displayed, check the battery.

INSPECTION PROCEDURE CLASSIFIED BY DIAGNOSIS CODE

Code No.91 Side impact sensor (L.H.) power supply circuit system	Probable cause
This diagnosis code is output if the power supply voltage of the side impact sensor (L.H.) drops below the rated value for a continuous period of 5 seconds or more. However, code No.91 will be automatically cleared and the SRS warning lamp will switch off if the condition returns to normal.	<ul style="list-style-type: none"> ● Malfunction of wiring harnesses or connectors ● Malfunction of side impact sensor (L.H.) ● Malfunction of SRS-ECU

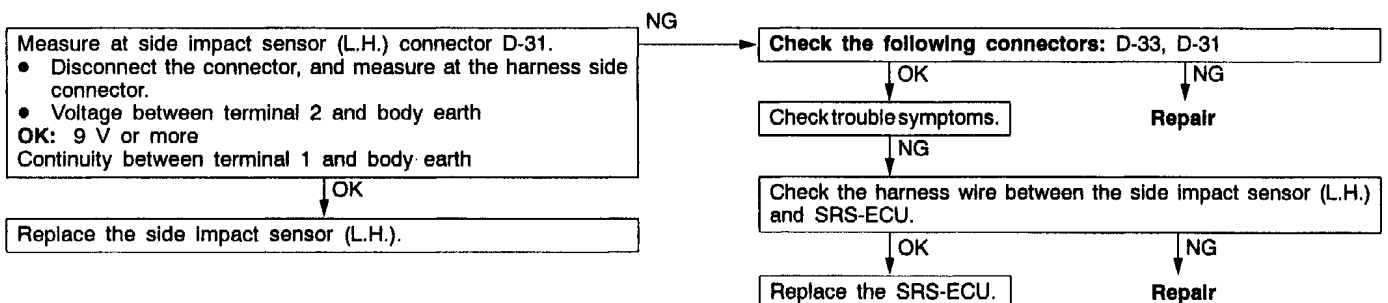

INSPECTION CHART FOR TROUBLE SYMPTOMS

Get an understanding of the trouble symptoms and check according to the inspection procedure chart.

Trouble symptom		Inspection procedure No.	Reference page
Communication with MUT-II is not possible.	Communication with all systems is not possible.	1	Refer to '96 CARISMA Basic Manual
	Communication is not possible with SRS only.	2	52B-5
When the ignition key is turned to ON (engine stopped), the SRS warning lamp does not illuminate.		Refer to diagnosis code No.43.	Refer to '98 CARISMA (except GDI) Workshop Manual
After the ignition switch is turned to ON, the SRS warning lamp is still on after approximately 7 seconds have passed.		Refer to diagnosis code No.43.	Refer to '98 CARISMA (except GDI) Workshop Manual
		Refer to diagnosis code No.44.	Refer to '96 CARISMA Basic Manual

INSPECTION PROCEDURE FOR TROUBLE SYMPTOMS

Inspection Procedure 2

Communication with MUT-II is not possible. (Communication is not possible with SRS only.)	Probable cause
If communication is not possible with the SRS only, the cause is probably an open circuit in the diagnosis output circuit of the SRS or in the power circuit (including earth circuit).	<ul style="list-style-type: none"> Malfunction of wiring harnesses or connectors Malfunction of SRS-ECU

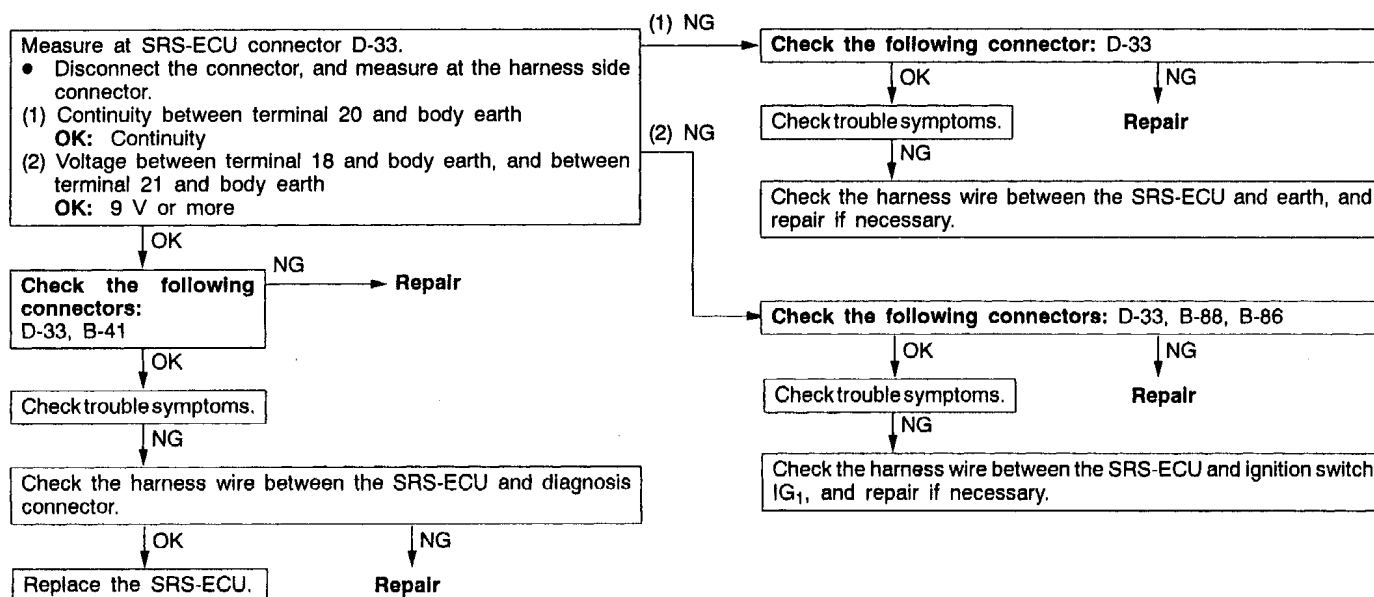

AIR BAG MODULES AND CLOCK SPRING

Caution

1. Disconnect the battery (-) terminal and wait for 60 seconds or more before starting work. Furthermore, the disconnected battery terminal should be covered with tape to insulate it. (Refer to '96 CARISMA Basic Manual.)
2. Never attempt to disassemble or repair the air bag modules or clock spring. If faulty, replace it.
3. Do not drop the air bag modules or clock spring or allow contact with water, grease or oil. Replace it if a dent, crack, deformation or rust is detected.
4. The air bag modules should be stored on a flat surface and placed so that the pad surface is facing upward. Do not place anything on top of it.
5. Do not expose the air bag modules to temperatures over 93°C.
6. After deployment of an air bag, replace the clock spring with a new one.
7. Wear gloves and safety glasses when handling air bags that have already deployed.
8. An undeployed air bag module should only be disposed of in accordance with the procedures (Refer to '96 CARISMA Basic Manual.)

REMOVAL AND INSTALLATION

<Air bag module (front passenger's side)>

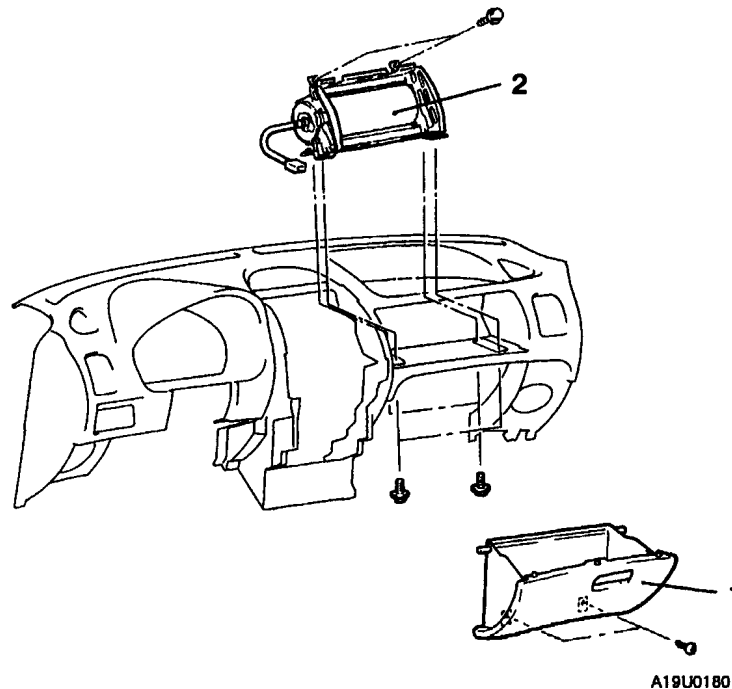

Air bag module removal steps

- ▶B◀ ● Post-installation inspection
- Negative (-) battery cable connection
- 1. Glove box
- 2. Air bag module
- ◀A▶ ● Pre-installation inspection

REMOVAL SERVICE POINT**◀A▶ AIR BAG MODULE REMOVAL (FRONT PASSENGER'S SIDE)****Caution**

The removed air bag module should be stored in a clean, dry place with the pad cover face up.

INSTALLATION SERVICE POINTS**▶A◀ PRE-INSTALLATION INSPECTION**

1. When installing the new air bag modules and clock spring, refer to "INSPECTION".

Caution

Dispose of air bag modules only according to the specified procedure. (Refer to '96 CARISMA Basic Manual.)

2. Connect the battery (-) terminal.
3. Connect the MUT-II to the diagnosis connector.

Caution

Make certain that the Ignition switch is LOCK (OFF) position when the MUT-II is connected or disconnected.

4. Turn the ignition switch to the ON position.
5. Conduct self-diagnosis using the MUT-II to ensure entire SRS operates properly, except open circuit of air bag modules.
6. Turn the ignition switch to the LOCK (OFF) position, disconnect the negative battery cable and tape the terminal.

Caution

Wait at least 60 seconds after disconnecting the battery cable before doing any further work. (Refer to '96 CARISMA Basic Manual.)

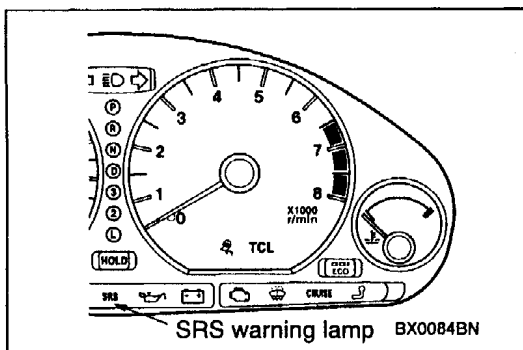
**▶B◀ POST-INSTALLATION INSPECTION**

1. Reconnect the negative battery terminal.
2. Turn the ignition switch to the ON position.
3. Does the SRS warning lamp illuminate for about 7 seconds, and then remain extinguished for at least 5 seconds after turning OFF?
4. If yes, SRS system is functioning properly. If no, consult page 52B-3.

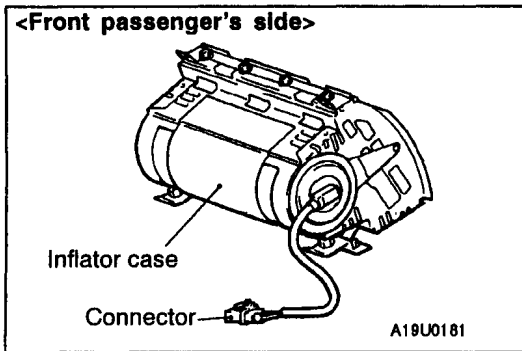

INSPECTION

AIR BAG MODULES CHECK

If any improper part is found during the following inspection, replace the air bag modules with a new one. Dispose of the old one according to the specified procedure. (Refer to '96 CARISMA Basic Manual.)

Caution

Never attempt to measure the circuit resistance of the air bag modules (squib) even if you are using the specified tester. If the circuit resistance is measured with a tester, accidental air bags deployment will result in serious personal injury.

1. Check pad cover for dents, cracks or deformation.
2. Check connectors for damage, terminals for deformation, and harness for binds.
3. Check air bag inflator case for dents, cracks or deformation.
4. Install the air bag module to steering wheel to check fit or alignment with the wheel.

Caution

If dents, cracks, deformation, or rust are discovered in the air bag module, replace it with a new one. Dispose of the old one according to the specified procedure. (Refer to '96 CARISMA Basic Manual.)

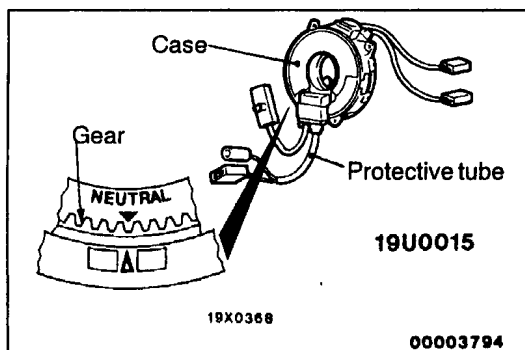

CLOCK SPRING CHECK

If, as result of following checks, even one abnormal point is discovered, replace the clock spring with a new one.

1. Check connectors and protective tube for damage, and terminals for deformation.
2. Visually check the case and the gears for damage.

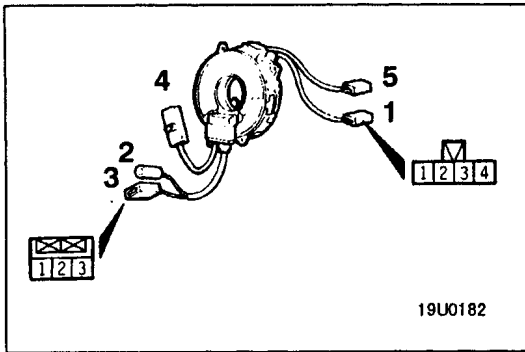

3. Check for continuity between the No. 1 connector of the clock spring and connectors No. 2 and 3.

Connector No.	1				2	3		
Terminal No.	1	2	3	4	1	1	2	3
Continuity between terminals			○	○	○	○		
	○						○	
		○						○

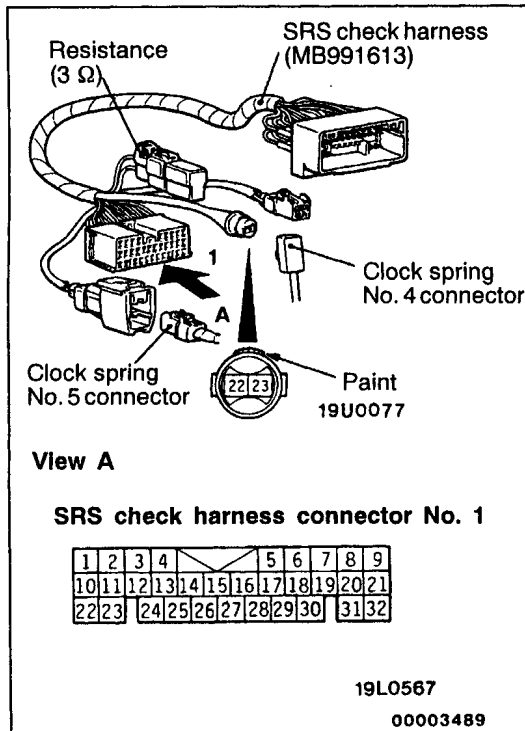

4. Joint the No. 4 and 5 connectors of the clock spring to the connector of the SRS Check Harness.
5. Check for continuity between terminal 22 and terminal 25, and terminal 23 and terminal 24, of SRS Check Harness connector No. 1 using a digital multi-meter.

SIDE IMPACT SENSOR

Caution

1. Disconnect the battery (-) terminal and wait for 60 seconds or more before starting work. Furthermore, the disconnected battery terminal should be covered with tape to insulate it. (Refer to '96 CARISMA Basic Manual.)
2. Never attempt to disassemble or repair the side impact sensor. If faulty, replace it.

3. Do not drop or subject the side impact sensor to impact or vibration. If denting, cracking, deformation, or rust are discovered in the side impact sensor, replace it with a new side impact sensor. Discard the old one.
4. After deployment of an air bag, replace the side impact sensor with a new one.

REMOVAL AND INSTALLATION

Pre-removal Operation

Turn the ignition switch to the LOCK (OFF) position.

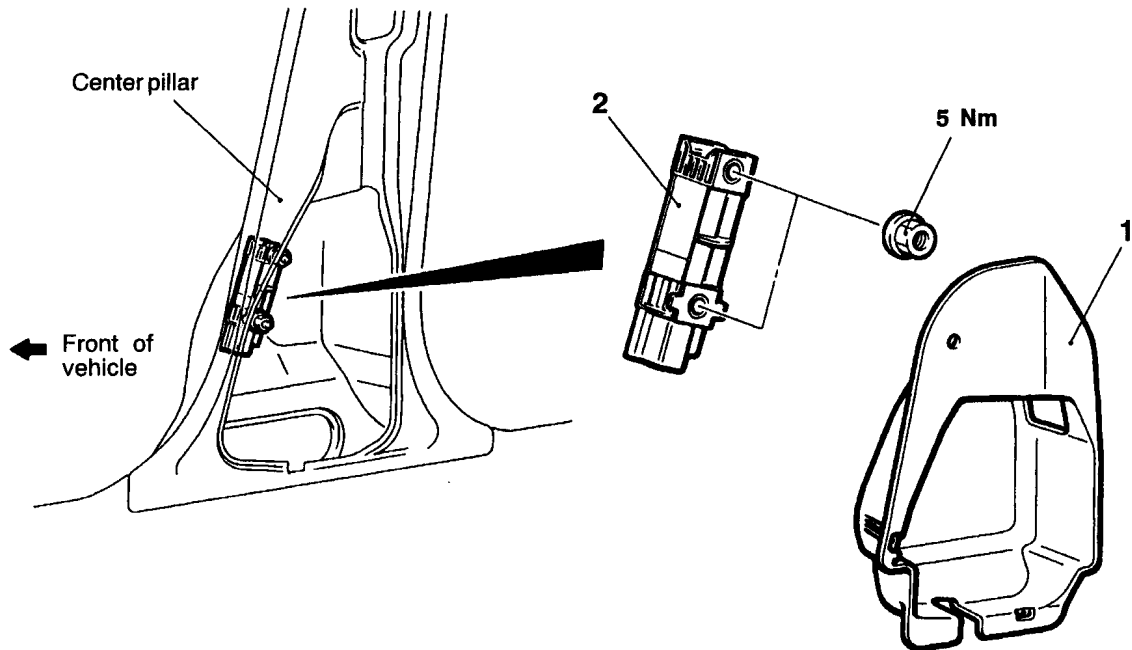

AX0037BN

Removal steps

- ▶C◀
- Post-installation inspection
 - Negative (-) battery cable connection
 - Center pillar lower trim (Refer to GROUP 52A.)
 - Seat belt with pre-tensioner (Refer to '96 CARISMA Basic Manual.)
1. Water proof cover

- ▶B◀ 2. Side impact sensor
▶A◀ • Pre-installation inspection

NOTE

The illustration above shows the side impact sensor (L.H.). The position of the side impact sensor (R.H.) is symmetrical to this.

INSTALLATION SERVICE POINTS**►A◄ PRE-INSTALLATION INSPECTION**

Check the side impact sensor for dents, breakage and bending and measure the resistance between the terminals, even when installing a new side impact sensor.

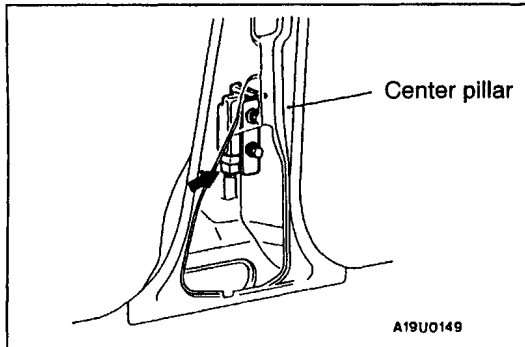
**►B◄ SIDE IMPACT SENSOR INSTALLATION**

Securely connect the connector.

Caution

If the side impact sensor is not installed securely and correctly, the side air bag may not operate normally.

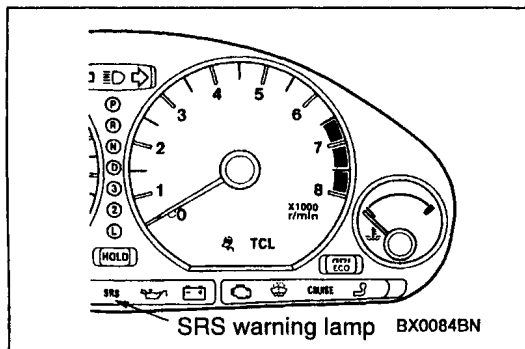
**►C◄ POST-INSTALLATION INSPECTION**

1. Reconnect the negative battery terminal.
2. Turn the ignition switch to the ON position.
3. Does the SRS warning lamp illuminate for about 7 seconds, and then remain extinguished for at least 5 seconds after turning the ignition switch to the LOCK (OFF) position?
4. If yes, SRS system is functioning properly. If no, consult page 52B-3.