

GROUP 37A

STEERING

GENERAL

OUTLINE OF CHANGE

The following service procedures have been added due to the introduction of the 1900-mL diesel engine. The other items are the same as before.

- Power steering oil pump
- Power steering hoses

POWER STEERING OIL PUMP

REMOVAL AND INSTALLATION

Pre-removal Operation
Power Steering Fluid Draining

Post-installation Operation

- Power Steering Fluid Supplying
- Drive-belt Tension Adjusting
(Refer to GROUP 11C – On-vehicle Service.)
- Power Steering Fluid Line Bleeding

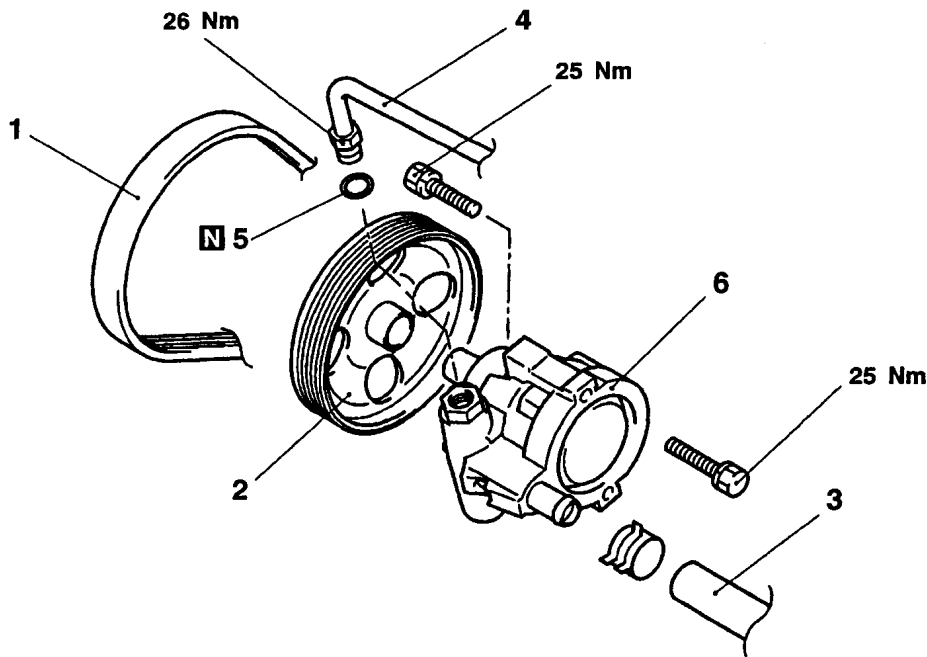

AY0205AJ

Removal steps

1. Drive-belt
2. Power steering pump pulley
3. Suction hose

4. Pressure hose
5. O-ring
6. Oil pump

INSPECTION

- Check the drive-belt for cracks.
- Check the pulley assembly for uneven rotation.

POWER STEERING HOSES

REMOVAL AND INSTALLATION

Pre-removal Operation
Power Steering Fluid Draining

Post-installation Operation

- Power Steering Fluid Supplying
- Power Steering Fluid Line Bleeding

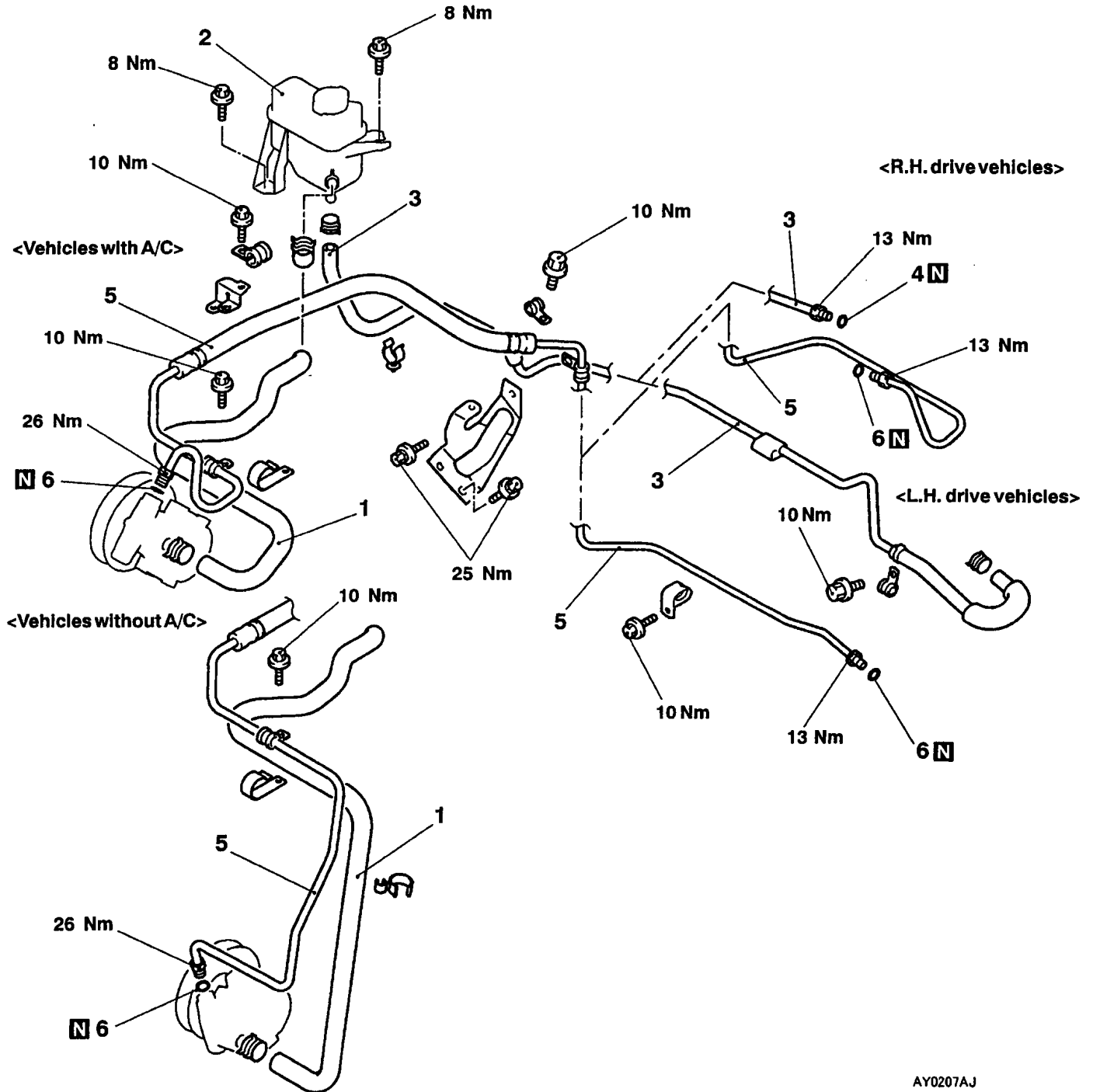

AY0207AJ

Removal steps

1. Suction hose
2. Oil reservoir
3. Return hose

4. O-ring
5. Pressure hose
6. O-ring