

---

# PROPELLER SHAFT

## CONTENTS

E25AA--

<b>SPECIFICATIONS</b> .....	<b>2</b>	<b>SPECIAL TOOLS</b> .....	<b>3</b>
General Specifications .....	2	<b>PROPELLER SHAFT</b> .....	<b>4</b>
Service Specifications .....	2		
Lubricants .....	2		
Sealant and Adhesives .....	3		

## SPECIFICATIONS

## GENERAL SPECIFICATIONS

E25CA--

Items		Specifications		
Propeller shaft	Type	3-joint type		
	Length × O.D. mm (in.)	Front	938.0 × 70 (36.93 × 2.76)	
		Rear	Hatchback	954.0 × 75 (37.56 × 2.95)
			Sedan	1014.0 × 75 (39.92 × 2.95)
			WAGON	986.0 × 70 (38.82 × 2.76)
Universal joint	Type	No. 1	Cross type	
		No. 2	Constant velocity type (Löbro joint, LJ87)	
		No. 3	Cross type	
	Lubrication	Oilless type		
	Size mm (in.)	Cross type joint journal O.D.	14.689 (0.5783)	
Constant velocity joint O.D.		94 (3.7)		

## NOTE

Propeller shaft length indicates the length between center points of each joint.

## SERVICE SPECIFICATIONS

E25CB--

Items		Specifications	
Standard value			
Journal axial play	mm (in.)	0.02–0.06 (0.0008–0.0024)	
Limit			
Propeller shaft runout (Dial indicator reading)			
Front	mm (in.)	0.6 (0.024) or less	
Rear	mm (in.)	0.6 (0.024) or less	

## LUBRICANTS

E25CD--

Items	Quantity	Specified lubricant
Sleeve yoke surface	As required	Hypoid gear oil SAE 75W–90 or 75W–85W conforming to API GL-4
Löbro joint assembly		
Outer and inner races ball grooves	As required	Repair kit grease
Löbro joint assembly inner part	45–55 g (1.59–1.94 oz.)	Repair kit grease



**SEALANT AND ADHESIVES**

E25CE--

Item	Specified sealants and adhesives	Remarks
Löbro joint rubber packing	Quick fix adhesive 3M ATD Part No. 8121 or equivalent	Quick-fix adhesive

**SPECIAL TOOLS**

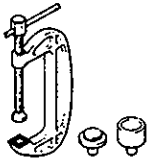
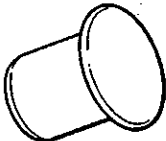
E25DA--

Tool	Number	Name	Use
	MB990840	Universal joint re- mover and installer	Disassembly/reassembly of the universal joint
	MB991193	Plug	Prevention of entry of foreign objects into the transfer
	MB990560 or MD998801	Bearing remover	Removal of the center bearing assembly

**PROPELLER SHAFT  
REMOVAL AND INSTALLATION**

E25GA--

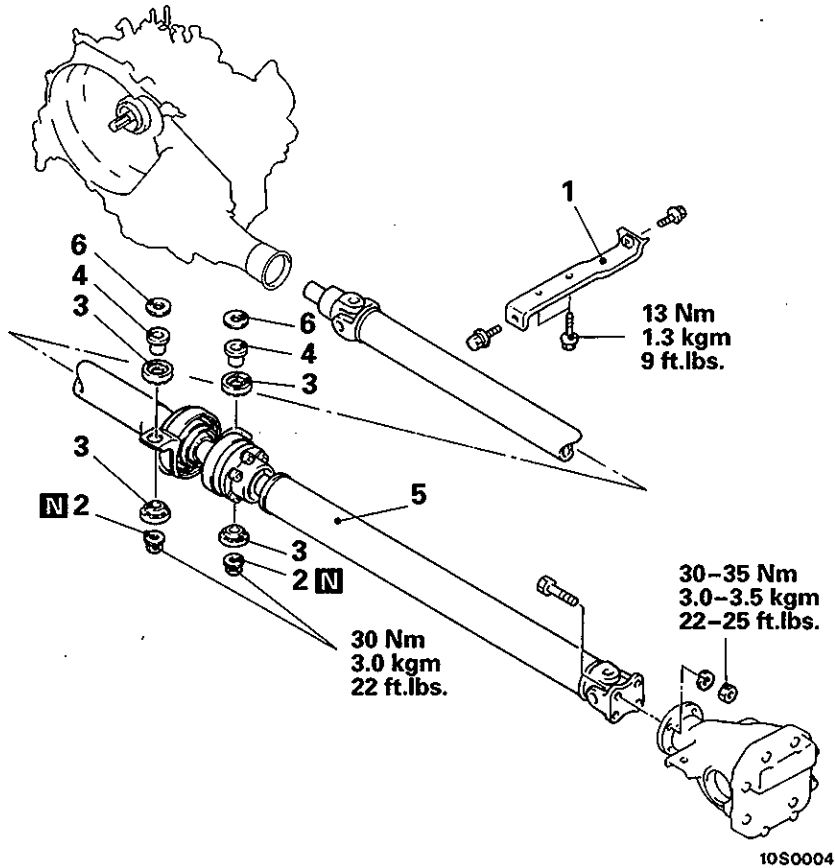

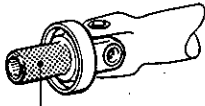

10G0001

**Gear oil:**  
Hypoid gear oil SAE  
75W-90 or 75W-85W  
conforming to API GL-4

**Removal steps**

1. Center exhaust pipe bracket
2. Self-locking nut
3. Insulator
4. Spacer
5. Propeller shaft assembly
6. Spacer

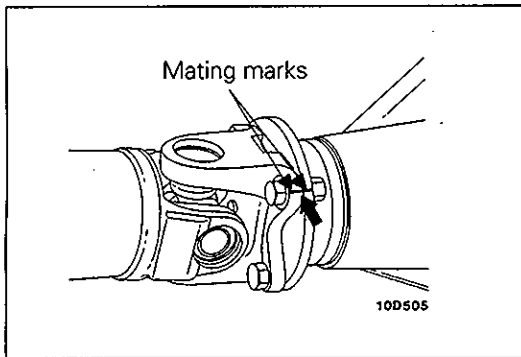

**SERVICE POINTS OF REMOVAL**

E25GBCD

**5. REMOVAL OF PROPELLER SHAFT**

- (1) Make mating marks on the differential companion flange and flange yoke and remove the propeller shaft.

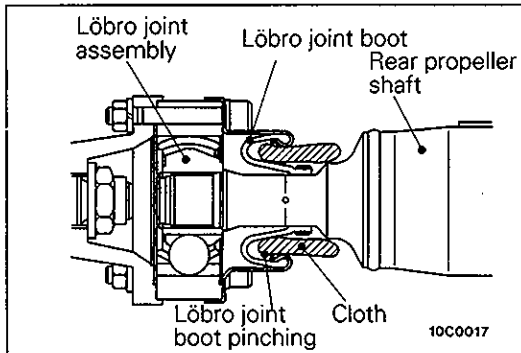

**Caution**

**Remove the propeller shaft in a straight and level manner so as to ensure that the boot is not damaged through pinching.**

**NOTE**

Damage to the boot can be avoided, and the work will be easier, if a piece of cloth or similar material is inserted in the boot.

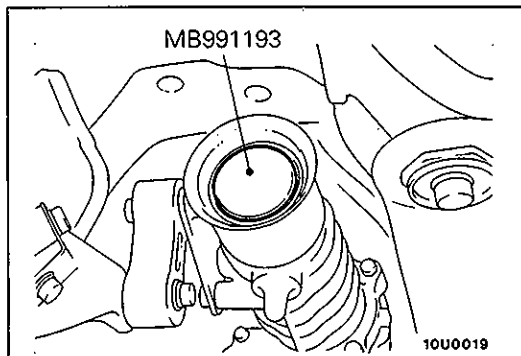

- (2) Use the special tool provided as a cover to prevent the entry of foreign objects into the transfer case.

**6. REMOVAL OF SPACER**

The number of spacers used on each vehicle differs. Check the number of spacers used and write it down for reference during reassembly.

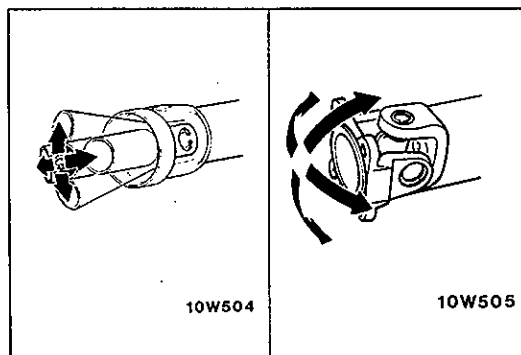

**INSPECTION**

E25GCAJ

- Check the sleeve yoke, center yoke and flange yoke for wear, damage or cracks.
- Check the propeller shaft yokes for wear, damage or cracks.
- Check the propeller shaft for bends, twisting or damage.
- Check the universal joints for smooth operation in all directions.
- Check the center bearing for smooth movement.
- Check the center bearing mounting rubber for damage or deterioration.

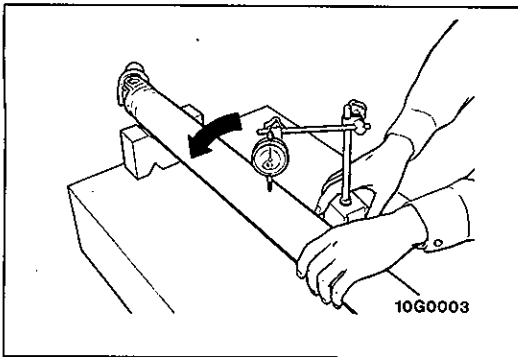
**PROPELLER SHAFT RUNOUT****Limit:**

Front propeller shaft  
Rear propeller shaft

0.6 mm (0.024 in.) or less  
0.6 mm (0.024 in.) or less

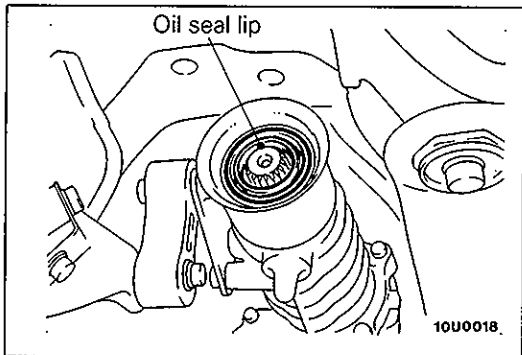
**SERVICE POINTS OF INSTALLATION**

E25GDAJ

**5. INSTALLATION OF PROPELLER SHAFT ASSEMBLY****Caution**

Be careful not to damage the lip section of the transfer case oil seal when installing the propeller shaft.

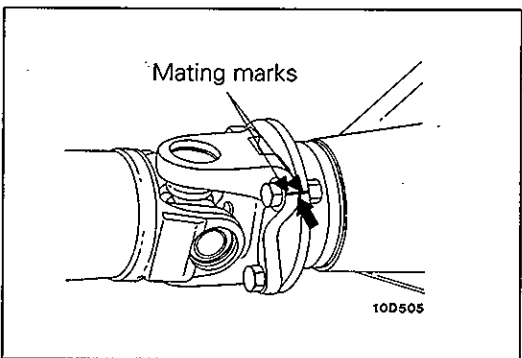

Install the propeller shaft to the companion flange with the mating marks properly aligned.

**Caution**

Tighten installation bolts after removing oil and grease from threads to prevent them from loosening due to lubrication.

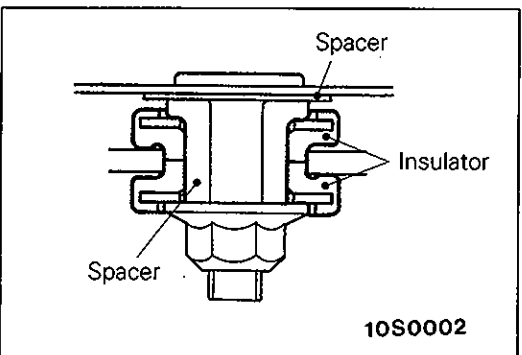
**6. INSTALLATION OF SPACER/4. SPACER/3. INSULATOR**

Install spacers and insulators as indicated in the illustration.

DISASSEMBLY AND REASSEMBLY

E25GE-

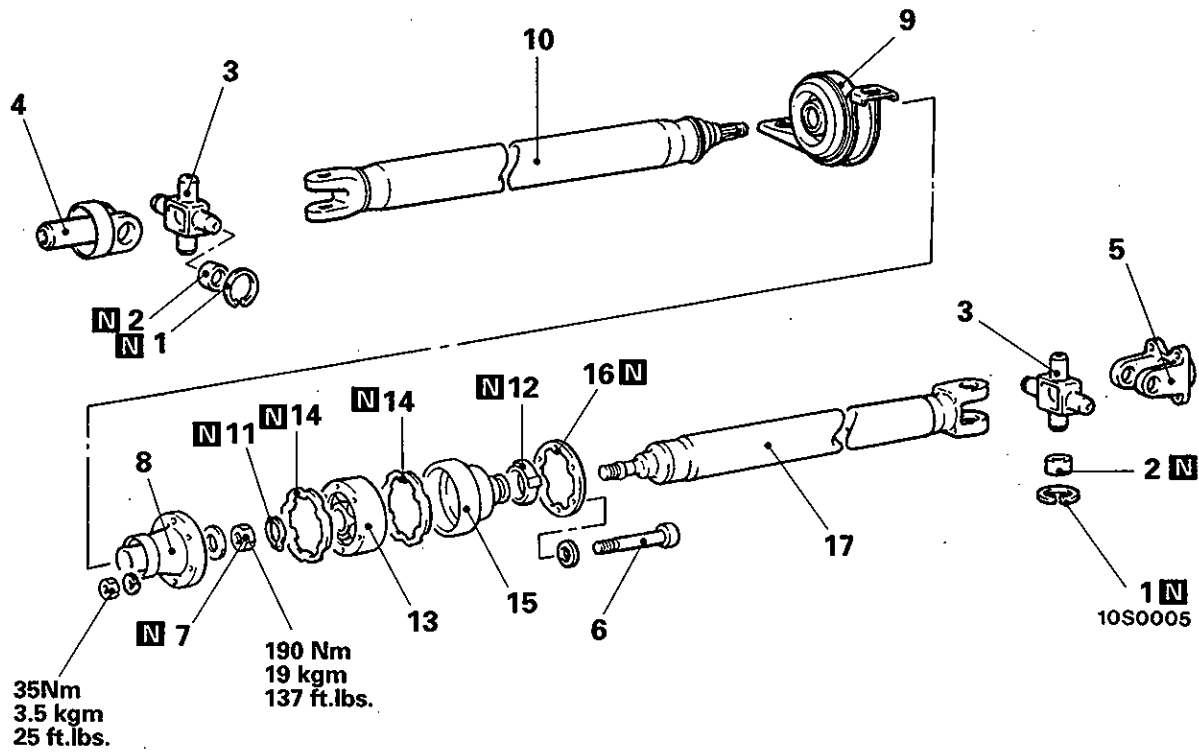

Disassembly steps

- ◆◆ ◆◆ 1. Snap ring
- ◆◆ ◆◆ 2. Journal bearing
- ◆◆ ◆◆ 3. Journal
- ◆◆ ◆◆ 4. Sleeve yoke
- ◆◆ ◆◆ 5. Flange yoke
- ◆◆ ◆◆ 6. Löbro joint assembly installation bolt
- ◆◆ ◆◆ 7. Self-locking nut
- ◆◆ ◆◆ 8. Companion flange
- ◆◆ ◆◆ 9. Center bearing assembly
- ◆◆ ◆◆ 10. Front propeller shaft
- ◆◆ ◆◆ 11. Snap ring
- ◆◆ ◆◆ 12. Boot band
- ◆◆ ◆◆ 13. Löbro joint assembly
- ◆◆ ◆◆ 14. Rubber packing
- ◆◆ ◆◆ 15. Löbro joint boot
- ◆◆ ◆◆ 16. Washer
- ◆◆ ◆◆ 17. Rear propeller shaft

Löbro joint kit	Universal joint kit
Löbro joint boot kit	

LUBRICATION AND ADHESION POINTS

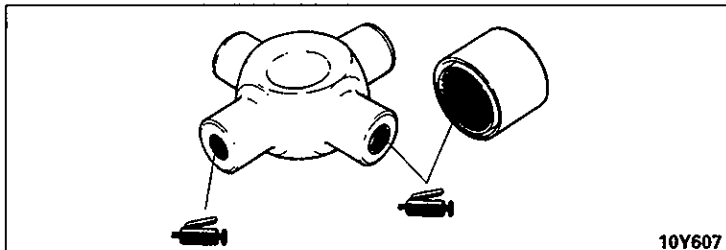

**Caution**  
Do not apply excessive grease. Otherwise, faulty fitting of bearing caps and errors in the selection of snap rings may result.

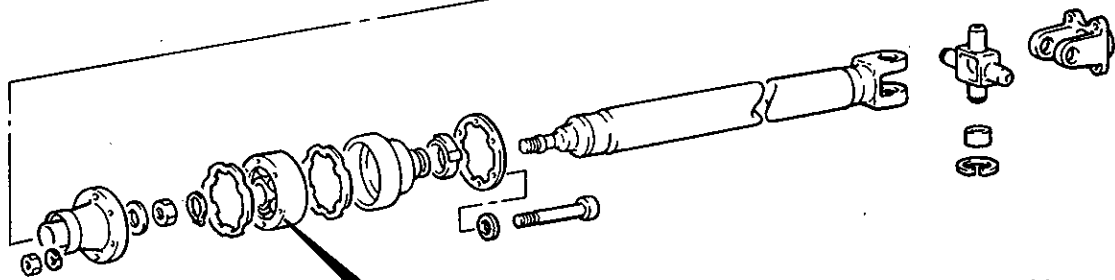
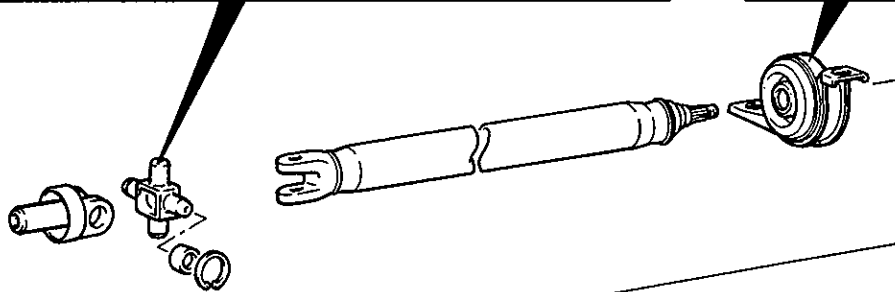
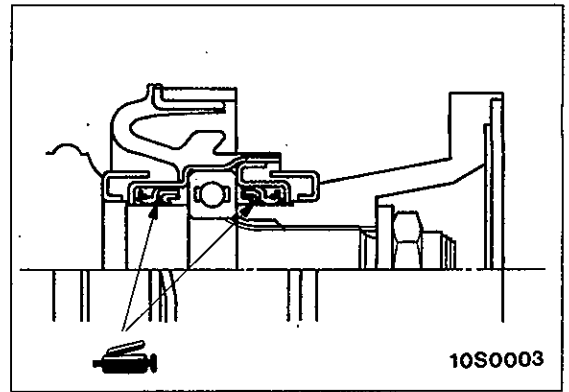

10S0005

<p><b>Löbro joint assembly</b></p> <p>Outer race Inner race 10C0016</p>	<p>10C0010</p>	<p>10N0009</p>
<p><b>Repair kit grease: 45–55 g (1.59–1.94 oz.)</b></p>		<p><b>Adhesive:</b> Quick fix adhesive 3M ATD Part No. 8121 or equivalent</p>



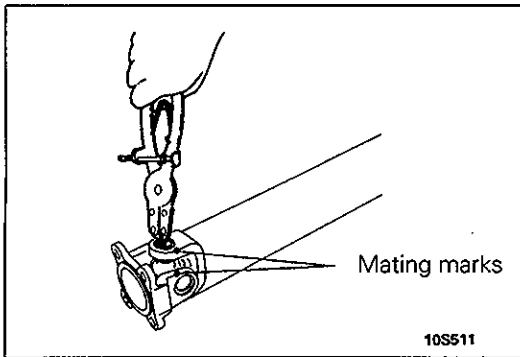

**SERVICE POINTS OF DISASSEMBLY**

E25GFAN

**1. REMOVAL OF SNAP RINGS**

Make mating marks on the yoke and propeller shaft and remove the snap rings from the yoke with snap ring pliers.

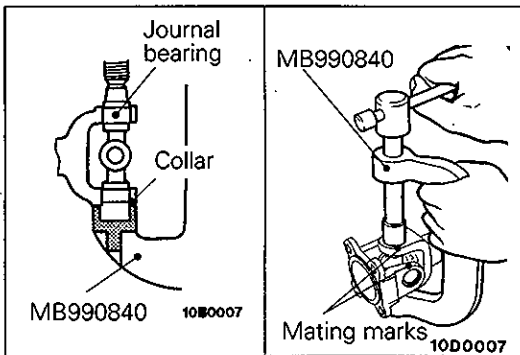

**2. REMOVAL OF JOURNAL BEARING**

Force out the journal bearings from the yoke and propeller shaft with a special tool.

**Caution**

**Do not tap the journal bearings to remove them, as this will upset the balance of the propeller shaft.**

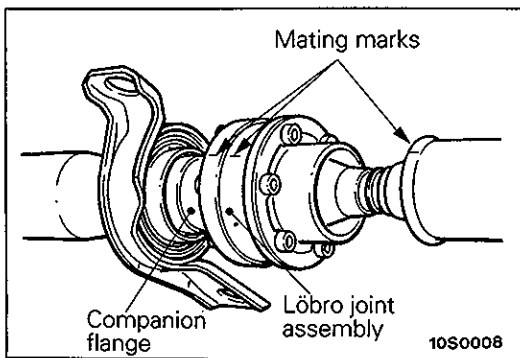

**6. REMOVAL OF LÖBRO JOINT ASSEMBLY INSTALLATION BOLT**

- (1) Place mating marks on the rear propeller shaft, companion flange and Löbro joint assembly.
- (2) Remove the Löbro joint installation bolts and separate the Löbro joint from the companion flange.

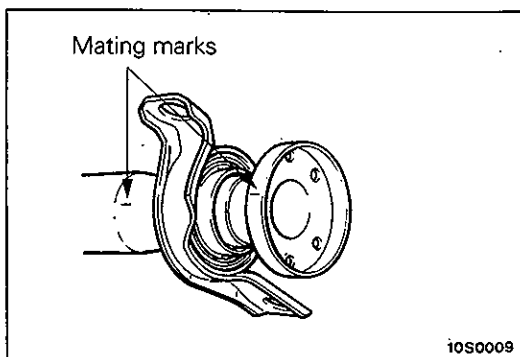

**7. REMOVAL OF SELF-LOCKING NUT/8. COMPANION FLANGE**

- (1) Place mating marks on the companion flange and front propeller shaft.
- (2) Remove the companion flange from front propeller shaft.

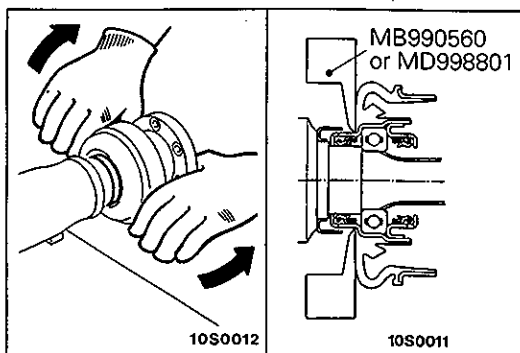

**9. REMOVAL OF CENTER BEARING ASSEMBLY**

- (1) Pull the center bearing bracket toward you and insert the special tool.

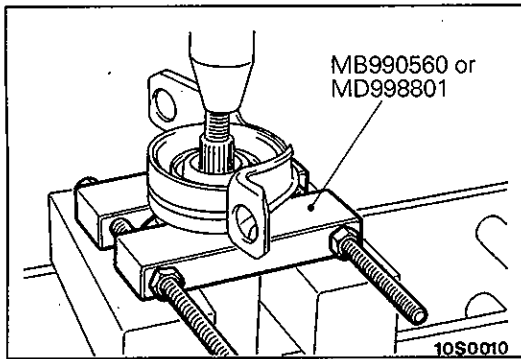

(2) Use a press to remove the center bearing assembly.

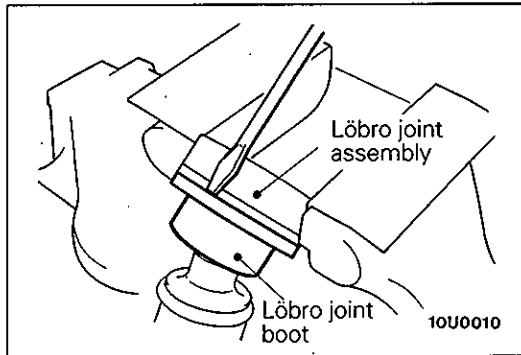

**13. REMOVAL OF LÖBRO JOINT ASSEMBLY**

Remove the Löbro joint assembly as follows:

(1) Remove the Löbro joint boot from the Löbro joint assembly

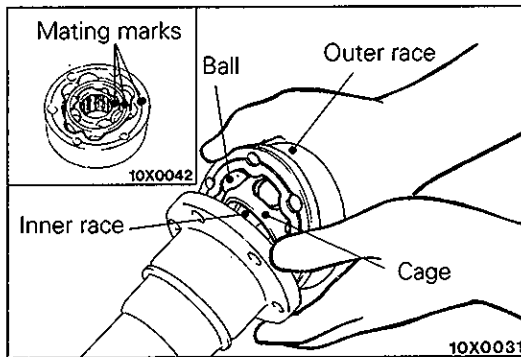

(2) Put mating marks on the outer race, cage and inner race with a scriber.

(3) Remove the outer race and balls.

**NOTE**

Note the positions of balls so that they can be reinstalled in their original positions.

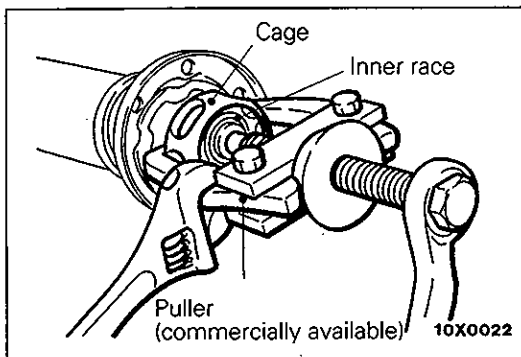

(4) Remove the inner race with cage from the rear propeller shaft by using a puller (commercially available).

**NOTE**

When changing the grease on the Löbro joint assembly, wipe off the grease and clean the outer and inner races, cage and balls.

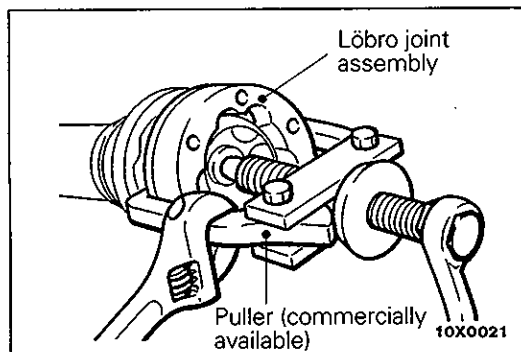

(5) If the outer race cannot be removed, remove the complete Löbro joint assembly from the rear propeller shaft by using a puller (commercially available).

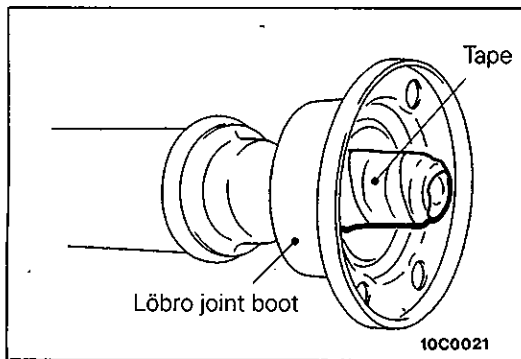

**15. REMOVAL OF LÖBRO JOINT BOOT**

When reusing the Löbro joint boot, apply adhesive tape to the serration section of the rear propeller shaft before removing.

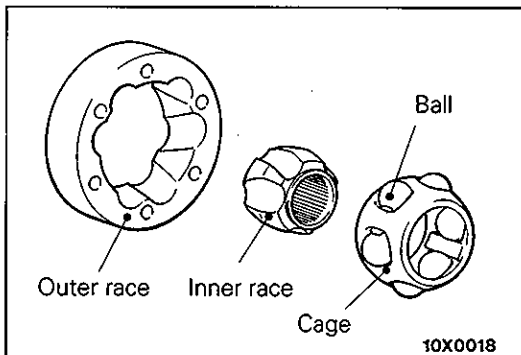

**INSPECTION**

E25GGAM

- Check the propeller shaft splines for wear or damage.
- Check the ball grooves in inner and outer races for uneven wear, damage or rust.
- Check ball surface for rust, wear or other damage.
- Check the cage for rust or damage.

**SERVICE POINTS OF REASSEMBLY**

E25GHAM

**15. INSTALLATION OF LÖBRO JOINT BOOT**

- (1) Before installing the Löbro joint boot, insert the boot band.
- (2) Wrap the splined end of propeller shaft with adhesive tape and install the Löbro joint boot.

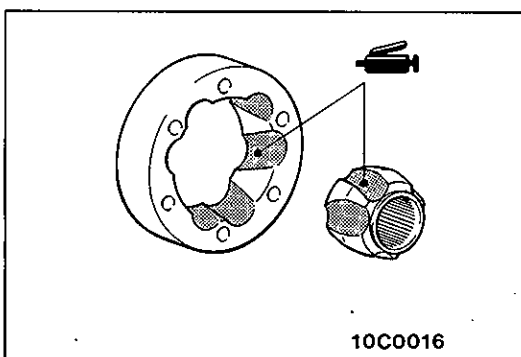

**13. INSTALLATION OF LÖBRO JOINT ASSEMBLY**

Install the Löbro joint assembly as follows:

- (1) Apply a thin coat of the specified grease to the ball grooves of the inner and outer races.

**Specified grease: Repair kit grease**

- (2) Put the cage on the inner race with the mating marks aligned and install two balls, one in a groove and the other in the groove opposite to that groove. Both balls should be placed in the grooves where they were before disassembly.
- (3) Assemble the inner race and cage in the outer race with their mating marks aligned.

**NOTE**

Make sure that the recessed end (where snap ring will be fitted) of the inner race, the recessed end (where packing will be fitted) of the outer race, and the chamfered end of the cage are all on the same side. Also ensure that the relative positions of the inner and outer races are as shown in the illustration.

- (4) Install the remaining balls in their original positions.
- (5) Check that the outer race rotates on the inner race smoothly.

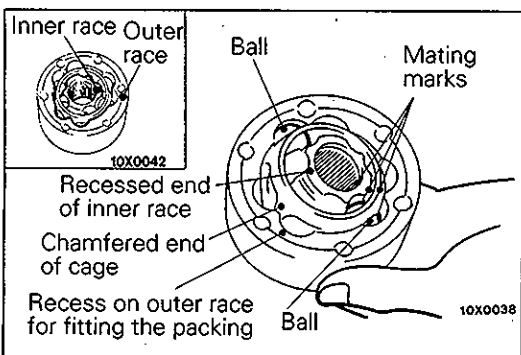

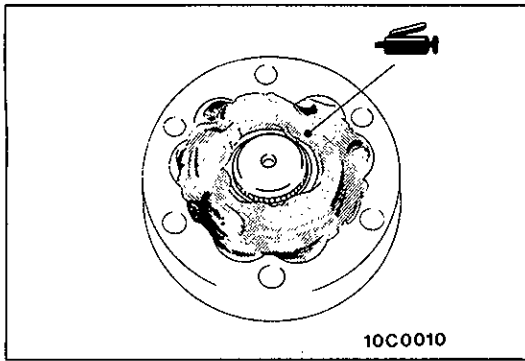

(6) Apply specified grease to the Löbro joint assembly.

**Specified grease: Repair kit grease  
[45–55 g (1.59–1.94 oz.)]**

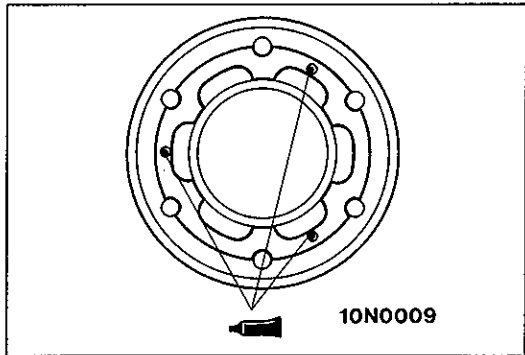

(7) Apply a small amount of specified adhesive in three equally divided places on the surface of the Löbro joint ball groove where there is a stepped section for the Löbro joint assembly packing, and then fit the rubber packing.

**Specified adhesive: Quick fix adhesive 3M ATD Part No. 8121 or equivalent**

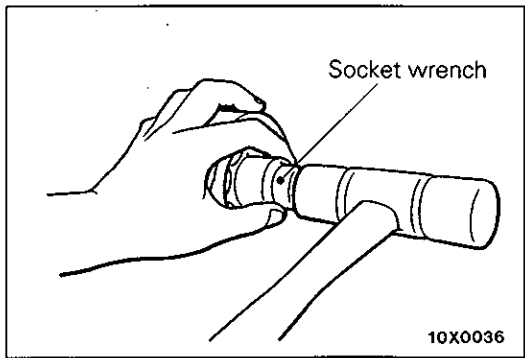

(8) Install the Löbro joint assembly on the rear propeller shaft while aligning their bolt holes, and drive the joint assembly with a hammer using a socket wrench on the inner race for complete installation.

**NOTE**

Install so that the surface where there is a stepped section for the Löbro joint assembly packing is facing toward the Löbro joint boot.

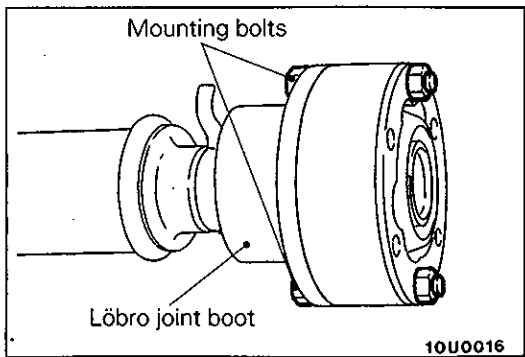

(9) Realign the bolt holes in the boot and Löbro joint assembly utilizing the mounting bolts and fit the boot on the joint assembly.

(10) Fit the rubber packing for the companion flange to the companion flange using the same procedure as in step (7).

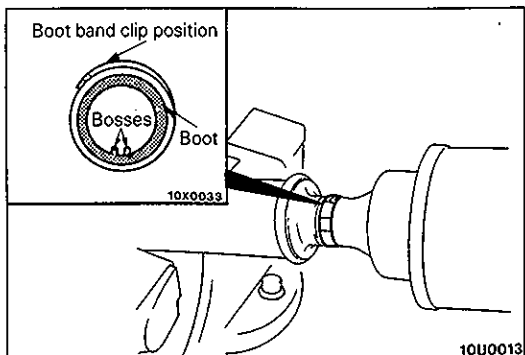

**12. INSTALLATION OF BOOT BAND**

**Caution**

**Position the boot band clip on the side opposite to the bosses which are provided in the boot for ventilation. Be sure to remove grease, if present, from around the bosses. Grease obstructs the ventilation air passage.**

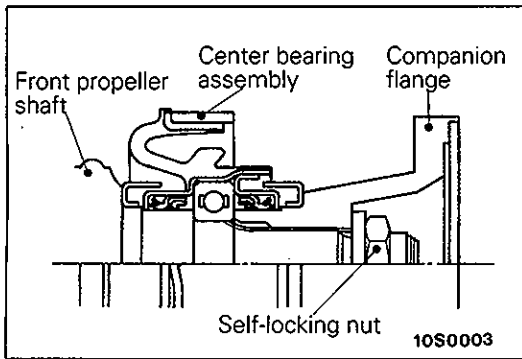

**9. INSTALLATION OF CENTER BEARING ASSEMBLY/  
8. COMPANION FLANGE/7. SELF-LOCKING NUT**

- (1) Install the dust seal of the center bearing assembly to the front propeller shaft so that it is facing the front propeller shaft.
- (2) Align the mating marks on the companion flange and front propeller shaft.
- (3) Press-fit the center bearing assembly with the companion flange while tightening the self-locking nut.

**6. INSTALLATION OF LÖBRO JOINT ASSEMBLY INSTALLATION BOLT**

Align the mating marks on the rear propeller shaft, companion flange and Löbro joint assembly.

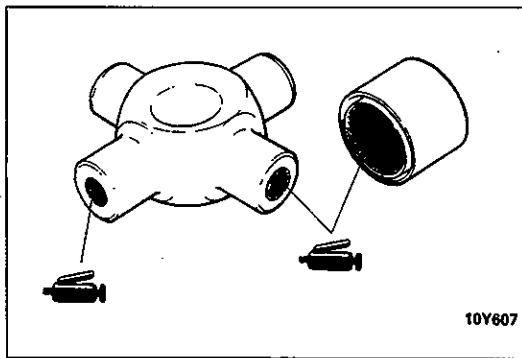

**3. INSTALLATION OF JOURNALS/2. JOURNAL BEARINGS**

- (1) Apply multipurpose grease to the following parts of the universal joint and bearing.
  - ① Shafts and grease sumps of journal
  - ② Dust seal lips
  - ③ Needle roller bearings

**Caution**

**Do not apply excessive grease. Otherwise, faulty fitting of bearing caps and errors in the selection of snap rings may result.**

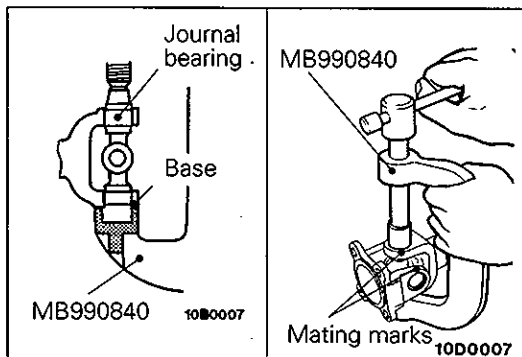

- (2) Press fit the journal bearings to the yoke by using the special tool according to the following procedures.

- ① Align the yoke and propeller shaft mating marks.
- ② Install the base to the special tool proper.
- ③ Insert both bearings in the yoke, and hold and press fit them by using the special tool.

**NOTE**

The bearing will stop in the regulated position due to the base.

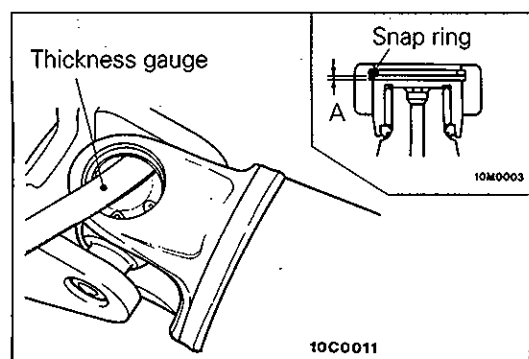

### 1. INSTALLATION OF SNAP RING

- (1) Install snap rings of the same thickness onto both sides of each yoke.
- (2) Press the bearing and journal into one side by using a brass bar.
- (3) Measure the clearance between the snap ring and the groove wall of the yoke with a thickness gauge.

**Standard value: 0.02–0.06 mm (0.0008–0.0024 in.)**

**Caution**

**Snap rings with the same thickness on each side should always be used.**

- (4) If the clearance exceeds the standard value, the snap rings should be replaced.

Snap ring thickness mm (in.)	Identification colour
1.28 (0.0503)	–
1.31 (0.0516)	Yellow
1.34 (0.0528)	Blue
1.37 (0.0539)	Purple