

# GENERAL

## CONTENTS

00109000348

<b>HOW TO USE THIS MANUAL</b> .....	<b>2</b>	Models .....	13
Scope of Maintenance, Repair and Servicing Explanations .....	2	Model Code .....	14
Definition of Terms .....	2	Chassis Number .....	15
Indication of Tightening Torque .....	2	Engine Model Number .....	16
Model Indications .....	3	<b>MAJOR SPECIFICATIONS</b> .....	<b>17</b>
Explanation of Manual Contents .....	4	<b>PRECAUTIONS BEFORE SERVICE</b> .....	<b>19</b>
<b>HOW TO USE TROUBLESHOOTING/INSPECTION SERVICE POINTS</b> .....	<b>6</b>	<b>SUPPLEMENTAL RESTRAINT SYSTEM (SRS) AND SEAT BELT WITH PRE-TENSIONER</b> .....	<b>23</b>
Troubleshooting Contents .....	6	<b>SUPPORT LOCATIONS FOR LIFTING AND JACKING</b> .....	<b>27</b>
Diagnosis Function .....	7	Support Positions for a Garage Jack and Axle Stands .....	27
How to Use the Inspection Procedures .....	9	Support Positions for a Single-Post Lift or Double-Post Lift .....	28
Connector Measurement Service Points .....	10	Support Positions and Support Method for an H-Bar Lift .....	29
Connector Inspection .....	11	<b>STANDARD PART/TIGHTENING-TORQUE TABLE</b> .....	<b>31</b>
Inspection Service Points for a Blown Fuse ...	12		
Points to Note for Intermittent Malfunctions ...	12		
<b>VEHICLE IDENTIFICATION</b> .....	<b>13</b>		
Vehicle Information Code Plate .....	13		

## HOW TO USE THIS MANUAL

00100010180

### SCOPE OF MAINTENANCE, REPAIR AND SERVICING EXPLANATIONS

This manual provides explanations, etc. concerning procedures for the inspection, maintenance, repair and servicing of the subject model. Note, however, that for engine and transmission-related component parts, this manual covers only on-vehicle inspections, adjustments, and the removal and installation procedures for major components.

For detailed information concerning the inspection, checking, adjustment, disassembly and reassembly of the engine, transmission and major components after they have been removed from the vehicle, please refer to separate manuals covering the engine and the transmission.

### ON-VEHICLE SERVICE

“On-vehicle Service” is procedures for performing inspections and adjustments of particularly important locations with regard to the construction and for maintenance and servicing, but other inspection (for looseness, play, cracking, damage, etc.) must also be performed.

### INSPECTION

Under this title are presented inspection and checking procedures to be performed by using special tools and measuring instruments and by feeling, but, for actual maintenance and servicing procedures, visual inspections should always be performed as well.

### DEFINITION OF TERMS

#### STANDARD VALUE

Indicates the value used as the standard for judging the quality of a part or assembly on inspection or the value to which the part or assembly is corrected and adjusted. It is given by tolerance.

#### LIMIT

Shows the standard for judging the quality of a part or assembly on inspection and means the maximum or minimum value within which the part or assembly must be kept functionally or in strength. It is a value established outside the range of standard value.

#### REFERENCE VALUE

Indicates the adjustment value prior to starting the work (presented in order to facilitate assembly and adjustment procedures, and so they can be completed in a shorter time).

#### CAUTION

Indicates the presentation of information particularly vital to the worker during the performance of maintenance and servicing procedures in order to avoid the possibility of injury to the worker, or damage to component parts, or a reduction of component or vehicle function or performance, etc.

### INDICATION OF TIGHTENING TORQUE

The tightening torque shown in this manual is a basic value with a tolerance of  $\pm 10\%$  except the following cases when the upper and lower limits of tightening torque are given.

- (1) The tolerance of the basic value is within  $\pm 10\%$ .
- (2) Special bolts or the like are in use.
- (3) Special tightening methods are used.

**MODEL INDICATIONS**

The following abbreviations are used in this manual for classification of model types.

M/T:	Indicates the manual transmission, or models equipped with the manual transmission.
A/T:	Indicates the automatic transmission, or models equipped with the automatic transmission.
SOHC:	Indicates an engine with the single overhead camshaft, or a model equipped with such an engine.
MVV:	Indicates the Mitsubishi Vertical Vortex engine, or models equipped with that engine.
MPI:	Indicates the multi-point injection, or engines equipped with the multi-point injection.
2WD:	Indicates the front wheel-drive vehicles.

## EXPLANATION OF MANUAL CONTENTS

Indicates procedures to be performed before the work in that section is started, and procedures to be performed after the work in that section is finished.

**Component Diagram**

A diagram of the component parts is provided near the front of each section in order to give a reader a better understanding of the installed condition of component parts.

Indicates (by symbols) where lubrication is necessary.

**Maintenance and Servicing Procedures**

The numbers provided within the diagram indicate the sequence for maintenance and servicing procedures.

- **Removal steps:**

The part designation number corresponds to the number in the illustration to indicate removal steps.

- **Disassembly steps:**

The part designation number corresponds to the number in the illustration to indicate disassembly steps.

- **Installation steps:**

Specified in case installation is impossible in reverse order of removal steps. Omitted if installation is possible in reverse order of removal steps.

- **Reassembly steps:**

Specified in case reassembly is impossible in reverse order of disassembly steps. Omitted if reassembly is possible in reverse order of disassembly steps.

**Classifications of Major Maintenance/Service Points**

When there are major points relative to maintenance and servicing procedures (such as essential maintenance and service points, maintenance and service standard values, information regarding the use of special tools, etc.), these are arranged together as major maintenance and service points and explained in detail.



: Indicates that there are essential points for removal or disassembly.



: Indicates that there are essential points for installation or reassembly.

**Symbols for Lubrication, Sealants and Adhesives**

Information concerning the locations for lubrication and for application of sealants and adhesives is provided, by using symbols, in the diagram of component parts or on the page following the component parts page, and explained.



: Grease  
(multipurpose grease unless there is a brand or type specified)



: Sealant or adhesive



: Brake fluid or automatic transmission fluid



: Engine oil, gear oil or air conditioner compressor oil



: Adhesive tape or butyl rubber tape

- Indicates the group title.
- Indicates the section title.
- Indicates the group number.
- Indicates the page number.

**STEERING – Power Steering Oil Pump** **37A-29**

---

**POWER STEERING GEAR BOX**  
REMOVAL AND INSTALLATION

Pre-removal Operation  
 (1) Power Steering Fluid Draining (Refer to P-37A-10)  
 (2) Air Cleaner Assembly Removal  
 (3) Under Cover Removal (Refer to GROUP 42 – Under Cover)

**Oil pump seal kit** and **Oil pump cartridge kit** diagrams showing components 1 through 7.

**Removal steps:**  
 1. Lower shaft assembly and gear box connecting bolt  
 2. Split pin  
 3. Connection for tie-rod end and knuckle  
 4. Connection for return tube  
 5. Connection for pressure tube  
 6. Clamp  
 7. Gear box assembly

**REMOVAL SERVICE POINTS**  
**▲ TIE-ROD END DISCONNECTION**  
 Caution  
 1. Using the special tool, loosen the tie rod and mounting nut. Only loosen the nut; do not remove it from the ball joint.  
 2. Support the special tool with a cord, etc. to prevent it from coming off.

**HEADLAMP RELAY CONTINUITY INSPECTION**

Battery voltage	Terminal No.				
	1	2	4	5	
Power is not supplied	⊕	⊖	⊕	⊖	
Power is supplied	⊕	⊖	⊕	⊖	

**35A-26 BASIC BRAKE SYSTEM – Master Cylinder and Brake Booster**

Lubrication and sealing points

Sealant: 3M ATD Part No. 8881 or equivalent

Denotes non-reusable part.

Denotes tightening torque. For bolts and nuts which do not have a tightening torque listed, refer to the "Standard Parts-tightening-torque Table".

Repair kit or set parts are shown. (Only very frequently used parts are shown.)

Operating procedures, cautions, etc. on removal, installation, disassembly and reassembly are described.

⊕—⊖ indicates that there is a continuity between the terminals.  
 ⊕—⊖ indicates terminals to which battery voltage is applied.

The title of the page (following the page on which the diagram of component parts is presented) indicating the locations of lubrication and sealing procedures.

# HOW TO USE TROUBLESHOOTING/INSPECTION SERVICE POINTS

00100020084

Troubleshooting of electronic control systems for which the MUT-II can be used follows the basic outline described below. Furthermore, even in systems for which the MUT-II cannot be used, part of these systems still follow this outline.

## TROUBLESHOOTING CONTENTS

### 1. STANDARD FLOW OF DIAGNOSIS TROUBLESHOOTING

The troubleshooting sections follow the basic diagnosis flow which is given below. If the diagnosis flow is different from that given below, or if additional explanation is required, the details of such differences or additions will also be listed.

#### Diagnosis method

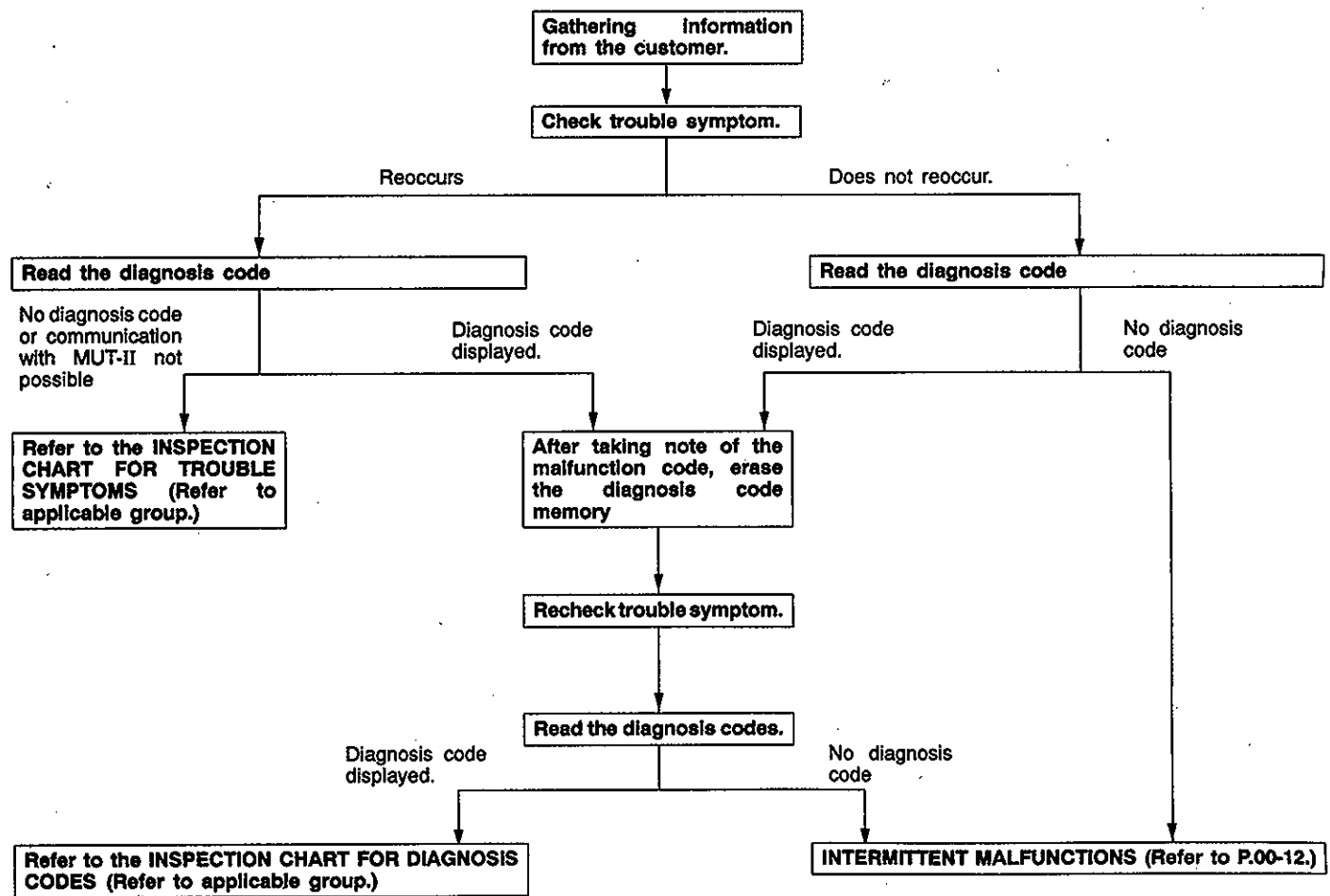

### 2. SYSTEM OPERATION AND SYMPTOM VERIFICATION TESTS

If verification of the trouble symptoms is difficult, procedures for checking operation and verifying trouble symptoms are shown.

### 3. DIAGNOSIS FUNCTION

Details which are different from those in the "Diagnosis Function" section on the next page are listed.

**4. INSPECTION CHART FOR DIAGNOSIS CODES****5. INSPECTION PROCEDURE FOR DIAGNOSIS CODES**

Indicates the inspection procedures corresponding to each diagnosis code. (Refer to P.00-9 for how to read the inspection procedures.)

**6. INSPECTION CHART FOR TROUBLE SYMPTOMS**

If there are trouble symptoms even though the results of inspection using the MUT-II show that all diagnosis codes are normal, inspection procedures for each trouble symptom will be found by means of this chart.

**7. INSPECTION PROCEDURE FOR TROUBLE SYMPTOM**

Indicates the inspection procedures corresponding to each trouble symptoms classified in the Inspection Chart for Trouble Symptoms. (Refer to P.00-9 for how to read the inspection procedures.)

**8. SERVICE DATA REFERENCE TABLE**

Inspection items and normal judgement values have been provided in this chart as reference information.

**9. CHECK AT ECU TERMINALS**

Terminal numbers for the ECU connectors, inspection items and standard values have been provided in this chart as reference information.

**10. INSPECTION PROCEDURES USING AN OSCILLOSCOPE**

When there are inspection procedures using an oscilloscope, these are listed here.

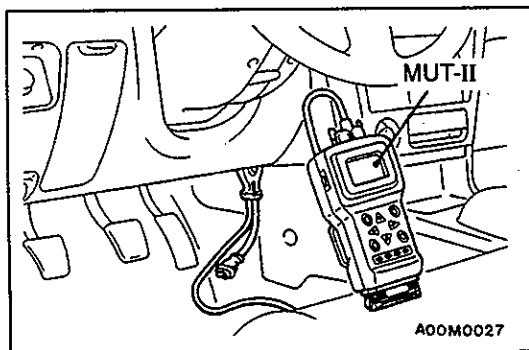
**DIAGNOSIS FUNCTION****METHOD OF READING DIAGNOSIS CODES  
WHEN USING THE MUT-II**

Connect the MUT-II to the diagnosis connector and take a reading of the diagnosis codes.

**Caution**

Turn off the ignition switch before connecting or disconnecting the MUT-II.

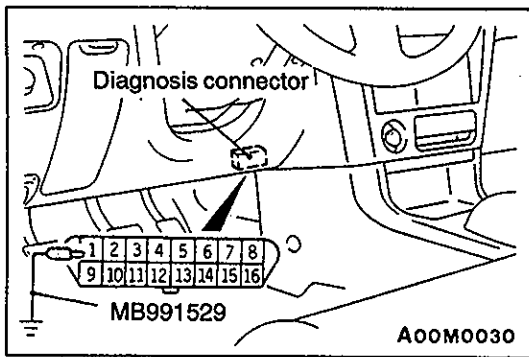

**WHEN USING THE WARNING LAMP**

1. Use the special tool to earth No.1 terminal (diagnosis control terminal) of the diagnosis connector.
2. To check ABS system, remove the valve relay.

**NOTE**

That is because the valve relay is off and the warning lamp remains illuminated if there is a fault in the ABS system.

3. Turn off the ignition switch.
4. Read out a diagnosis code by observing how the warning lamp flashes.

**Applicable systems**

System name	Warning lamp name
MPI	Engine warning lamp
A/T	Neutral position indicator lamp
ABS	ABS warning lamp

**Indication of diagnosis code by warning lamp**

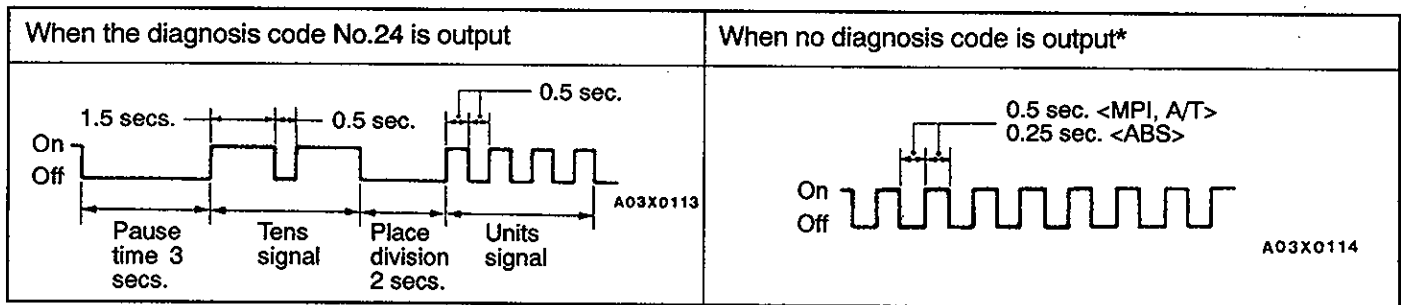

**NOTE**

\*: Even if the ABS system is normal, removing the valve relay causes the diagnosis code No.52 to be output.

**METHOD OF ERASING DIAGNOSIS CODES**

**WHEN USING THE MUT-II**

Connect the MUT-II to the diagnosis connector and erase the diagnosis code.

**Caution**

**Turn off the ignition switch before connecting or disconnecting the MUT-II.**

**WHEN NOT USING THE MUT-II**

- (1) Turn the ignition switch to OFF.
- (2) After disconnecting the battery cable from the battery (-) terminal for 10 seconds or more, reconnect the cable.
- (3) After the engine has warmed up, run it at idle for about 15 minutes.



## HOW TO USE THE INSPECTION PROCEDURES

The causes of a high frequency of problems occurring in electronic circuitry are generally the connectors, components, the ECU and the harnesses between connectors, in that order. These inspection procedures follow this order, and they first try to discover a problem with a connector or a defective component.

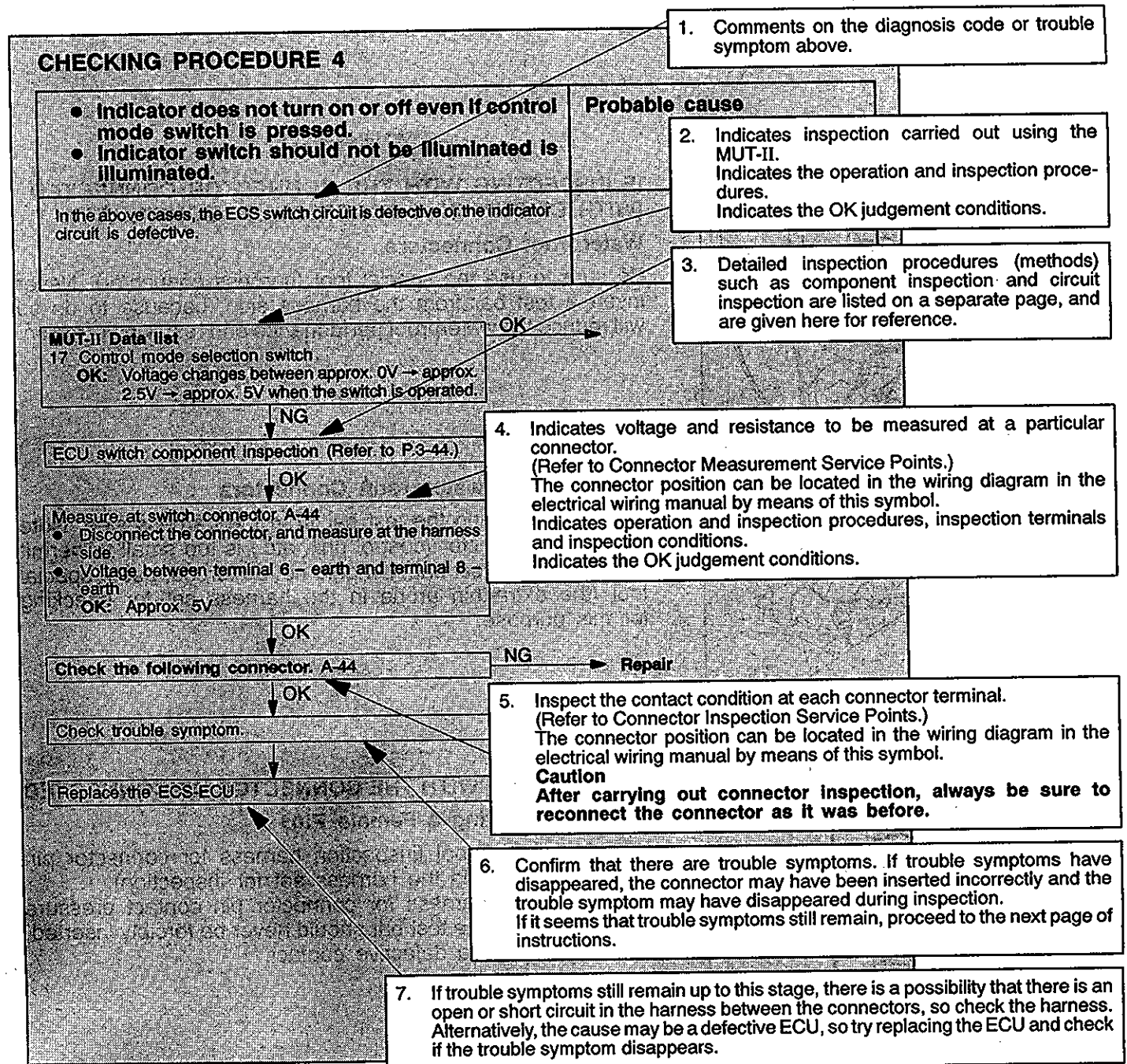

### HARNESS INSPECTION

Check for an open or short circuit in the harness between the terminals which were defective according to the connector measurements. Carry out this inspection while referring to the electrical wiring manual. Here, "Check harness between power supply and terminal xx" also includes checking for blown fuses. For inspection service points when there is a blown fuse, refer to "Inspection Service Points for a Blown Fuse."

### MEASURES TO TAKE AFTER REPLACING THE ECU

If the trouble symptoms have not disappeared even after replacing the ECU, repeat the inspection procedure from the beginning.

### CONNECTOR MEASUREMENT SERVICE POINTS

Turn the ignition switch to OFF when connecting/disconnecting the connectors, and turn the ignition switch to ON when measuring if there are no instructions to be contrary.

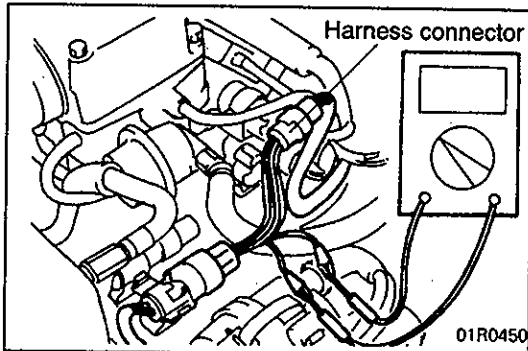

#### IF INSPECTING WITH THE CONNECTOR CONNECTED (WITH CIRCUIT IN A CONDITION OF CONTINUITY)

##### Waterproof Connectors

Be sure to use the special tool (harness connector). Never insert a test bar from the harness side, because to do so will reduce the waterproof performance and result in corrosion.

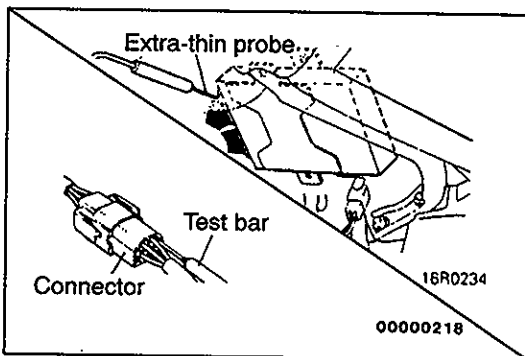

##### Ordinary (non-waterproof) Connectors

Check by inserting the test bar from the harness side. Note that if the connector (control unit, etc.) is too small to permit insertion of the test bar, it should not be forced; use a special tool (the extra-thin probe in the harness set for checking for this purpose).

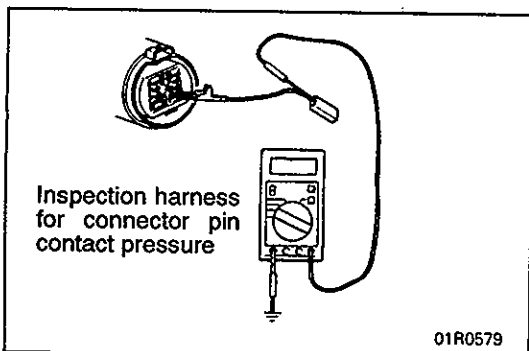

#### IF INSPECTING WITH THE CONNECTOR DISCONNECTED

##### <When Inspecting a Female Pin>

Use the special tool (inspection harness for connector pin contact pressure in the harness set for inspection). The inspection harness for connector pin contact pressure should be used. the test bar should never be forcibly inserted, as it may cause a defective contact.

##### <When Inspecting a Male Pin>

Touch the pin directly with the test bar.

##### Caution

At this time, be careful not to short the connector pins with the test bars. To do so may damage the circuits inside the ECU.

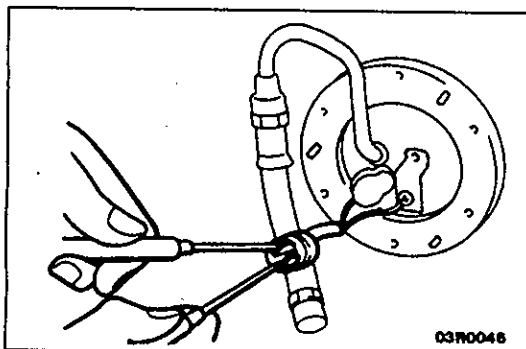

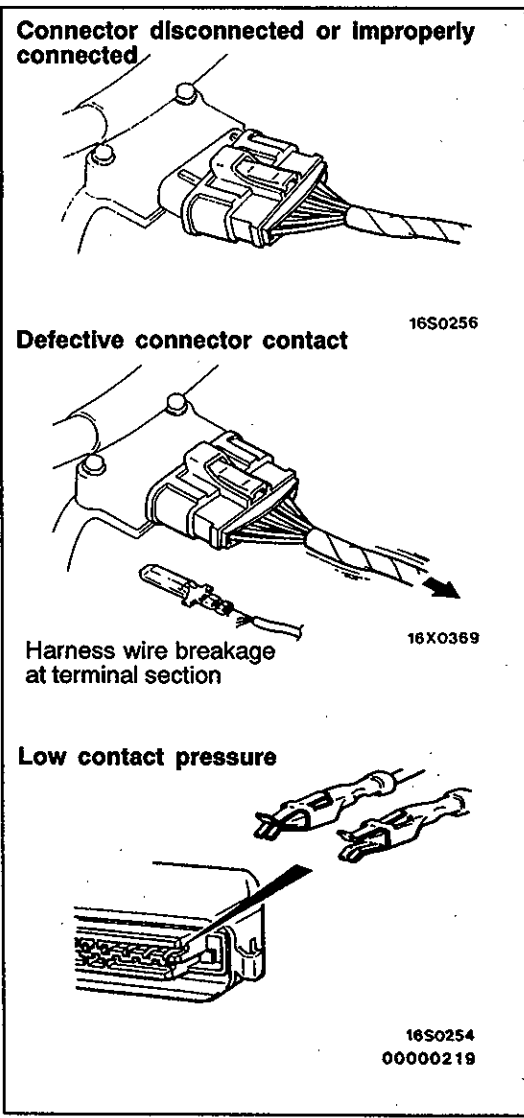

**CONNECTOR INSPECTION**

**VISUAL INSPECTION**

- Connector is disconnected or improperly connected
- Connector pins are pulled out
- Due to harness tension at terminal section
- Low contact pressure between male and female terminals
- Low connection pressure due to rusted terminals or foreign matter lodged in terminals

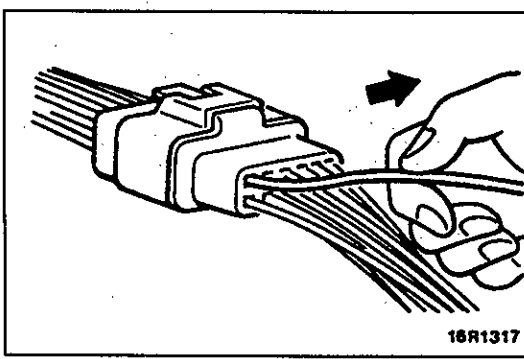

**CONNECTOR PIN INSPECTION**

If the connector pin stopper is damaged, the terminal connections (male and female pins) will not be perfect even if the connector body is connected, and the pins may pull out of the reverse side of the connector. Therefore, gently pull the harnesses one by one to make sure that no pins pull out of the connector.

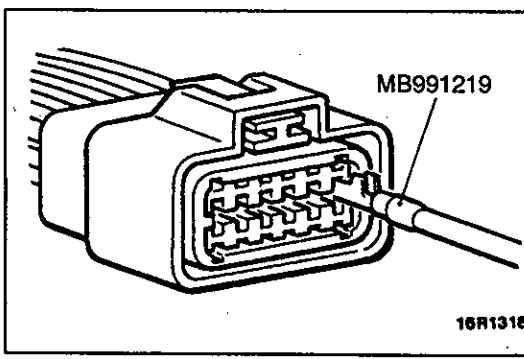

**CONNECTOR ENGAGEMENT INSPECTION**

Use the special tool (connector pin connection pressure inspection harness of the inspection harness set) to inspect the engagement of the male pins and females pins. (Pin drawing force : 1 N or more)

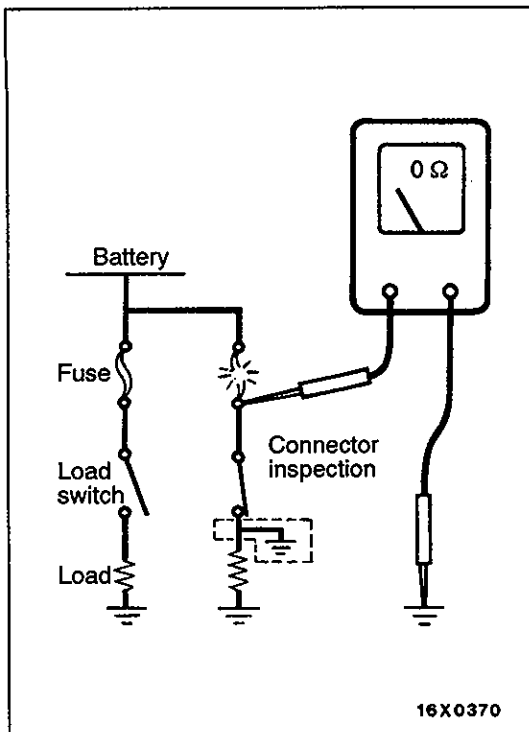

## INSPECTION SERVICE POINTS FOR A BLOWN FUSE

Remove the fuse and measure the resistance between the load side of the fuse and the earth. Set the switches of all circuits which are connected to this fuse to a condition of continuity. If the resistance is almost 0 Ω at this time, there is a short somewhere between these switches and the load. If the resistance is not 0 Ω, there is no short at the present time, but a momentary short has probably caused the fuse to blow.

The main causes of a short circuit are the following.

- Harness being clamped by the vehicle body
- Damage to the outer casing of the harness due to wear or heat
- Water getting into the connector or circuitry
- Human error (mistakenly shorting a circuit, etc.)

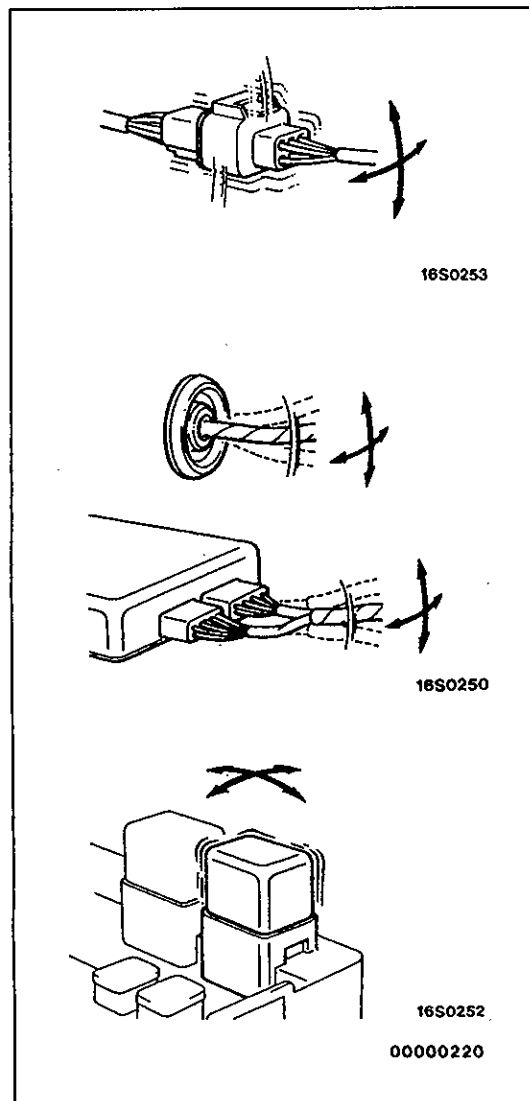

## POINTS TO NOTE FOR INTERMITTENT MALFUNCTIONS

Intermittent malfunctions often occur under certain conditions, and if these conditions can be ascertained, determining the cause becomes simple. In order to ascertain the conditions under which an intermittent malfunction occurs, first ask the customer for details about the driving conditions, weather conditions, frequency of occurrence and trouble symptoms, and then try to recreate the trouble symptoms. Next, ascertain whether the reason why the trouble symptom occurred under these conditions is due to vibration, temperature or some other factor. If vibration is thought to be the cause, carry out the following checks with the connectors and components to confirm whether the trouble symptom occurs.

The objects to be checked are connectors and components which are indicated by inspection procedures or given as probable causes (which generates diagnosis codes or trouble symptoms.)

- Gently shake the connector up, down and to the left and right.
- Gently shake the wiring harness up, down and to the left and right.
- Gently rock each sensor and relay, etc. by hand.
- Gently shake the wiring harness at suspensions and other moving parts.

### NOTE

If determining the cause is difficult, the flight recorder function of the MUT-II can also be used.

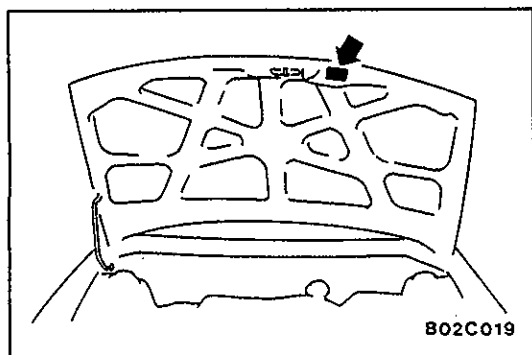

## VEHICLE IDENTIFICATION

00100540047

### VEHICLE INFORMATION CODE PLATE

#### LOCATION

Vehicle information code plate is riveted on the ~~top~~ board inside the engine compartment.

hood

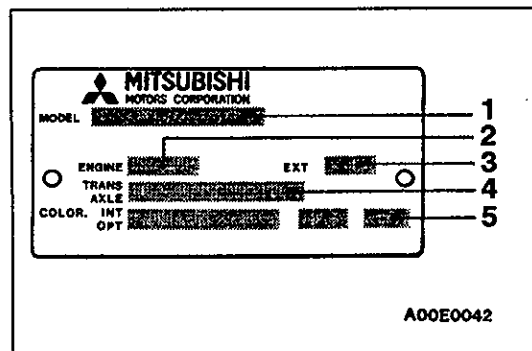

#### CODE PLATE DESCRIPTION

The plate shows model code, engine model, transmission model, and body colour code.

No.	Item	Contents	
1	MODEL	CJ1A	CJ1A: Vehicle model
		MNJEL6	MNJEL6: Model series
2	ENGINE	4G13	Engine model
3	EXT	B60B	Exterior code
4	TRANS AXLE	F5M41	Transmission code
5	COLOR INT OPT	B60	B60: Body colour code
		41H	41H: Interior code
		03V	03V: Equipment code

For monotone colour vehicles, the body colour code shall be indicated. For two-tone or three-way two-tone colour vehicles, each colour code only shall be indicated in series.

## MODELS

00100550040

### <Hatchback>

Model code		Engine model	Transmission model	Fuel supply system
CJ1A	MNDEL6	4G13-SOHC (1,299 ml)	F5M41 (2WD-5M/T)	MPI
	MNDER6			
	MNJEL6			
	MNJER6		F4A41 (2WD-4A/T)	
	MRJEL6			
	MRJER6			
CJ4A	MNJEL6	4G92-SOHC (1,597 ml)	F5M41 (2WD-5M/T)	MPI (MVV)
	MNJER6		F4A41 (2WD-4A/T)	
	MRJEL6			
	MRJER6			
	MNDAL6		F5M41 (2WD-5M/T)	
	MNDAR6			

## &lt;Sedan&gt;

Model code		Engine model	Transmission model	Fuel supply system
CK1A	SNDEL6	4G13-SOHC (1,299 mℓ)	F5M41 (2WD-5M/T)	MPI
	SNDER6			
	SNJEL6			
	SNJER6		F4A41 (2WD-4A/T)	
	SRJEL6			
	SRJER6			
CK4A	SNJEL6	4G92-SOHC (1,597 mℓ)	F5M41 (2WD-5M/T)	
	SNJER6			
	SRJEL6		F4A41 (2WD-4A/T)	
	SRJER6			

<b>CJ</b>	<b>1</b>	<b>A</b>	<b>M</b>	<b>N</b>	<b>J</b>	<b>E</b>	<b>L</b>	<b>6</b>
↓	↓	↓	↓	↓	↓	↓	↓	↓
<b>1</b>	<b>2</b>	<b>3</b>	<b>4</b>	<b>5</b>	<b>6</b>	<b>7</b>	<b>8</b>	<b>9</b>
00M0032								

## MODEL CODE

00100040110

No.	Items	Contents
1	Development	CJ: MITSUBISHI COLT
		CK: MITSUBISHI LANCER
2	Engine type	1: 1,299 mℓ petrol engine
		4: 1,597 mℓ petrol engine
3	Sort	A: Passenger car
4	Body style	M: 2-door hatchback
		S: 4-door sedan
5	Transmission type	N: 5-speed manual transmission
		R: 4-speed automatic transmission
6	Trim level	D: GL
		J: GLX
7	Specified engine feature	E: MPI-SOHC
		A: MPI-SOHC-MVV
8	Steering wheel location	L: Left hand
		R: Right hand
9	Destination	6: For Europe

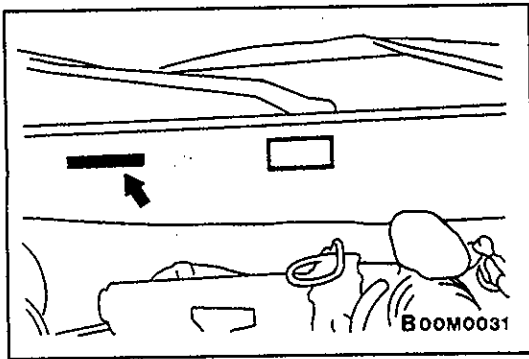

**CHASSIS NUMBER**

00100560043

The chassis number is stamped on the toeboard inside the engine compartment.

▲ J M B M N CJ 1 A T U 000001 ▲  
 1 2 3 4 5 6 7 8 9 10 11

00M0033

No.	Items	Contents
1	Fixed figure	J Asia
2	Distribution channel	M Japan channel
3	Destination	A For Europe, right hand drive
		B For Europe, left hand drive
4	Body style	M 2-door hatchback
		S 4-door sedan
5	Transmission type	N 5-speed manual transmission
		R 4-speed automatic transmission
6	Development order	CJ COLT
		CK LANCER
7	Engine	1 4G13: 1,299 ml petrol engine
		4 4G92: 1,597 ml petrol engine
8	Sort	A Passenger car
9	Model year	T 1996
10	Plant	U Mizushima Motor Vehicle Works
11	Serial number	-

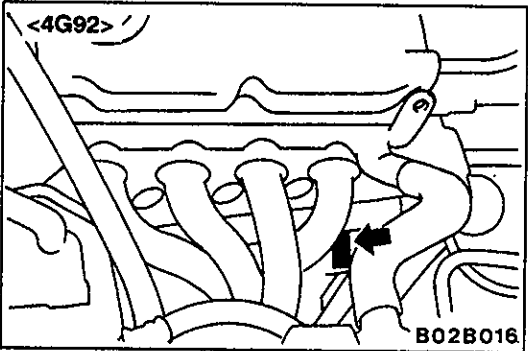
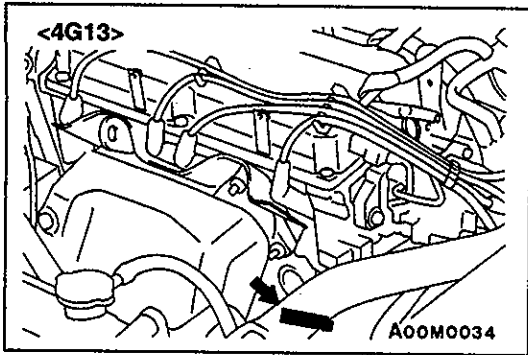

**ENGINE MODEL NUMBER**

00100570046

1. The engine model number is stamped at the cylinder block as shown in the following.

Engine model	Engine displacement ml
4G13	1,299
4G92	1,597

2. The engine serial number is stamped near the engine model number.

Engine serial number	AA0201 to YY9999
----------------------	------------------



MAJOR SPECIFICATIONS

00100090122

<HATCHBACK>

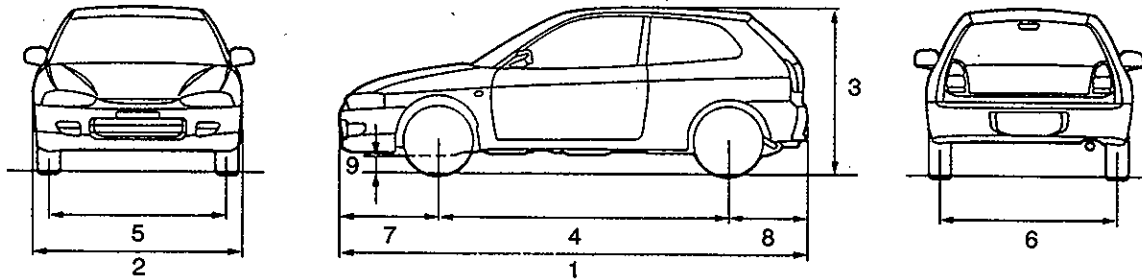

00M0035

Items		CJ1A MNDEL6, MNDER6	CJ1A MNJEL6, MNJER6	CJ1A MRJEL6, MRJER6	CJ4A MNJEL6, MNJER6	CJ4A MRJEL6, MRJER6	CJ4A MNDEL6, MNDER6	
Vehicle dimensions mm	Overall length	1	3,880	3,880	3,880	3,880	3,880	
	Overall width	2	1,680	1,680	1,680	1,680	1,680	
	Overall height (unladen)	3	1,365, 1,385*1	1,365, 1,385*1	1,365, 1,385*1	1,365, 1,385*1	1,365, 1,385*1	
	Wheelbase	4	2,415	2,415	2,415	2,415	2,415	
	Track-front	5	1,450	1,450	1,450	1,450	1,450	
	Track-rear	6	1,460	1,460	1,460	1,460	1,460	
	Overhang-front	7	805	805	805	805	805	
	Overhang-rear	8	660	660	660	660	660	
	Ground clearance (unladen)	9	150	150	150	150	150	
Vehicle weight kg	Kerb weight		945	950	970	975	995	
	Max. gross vehicle weight rating		1,445, 1,495*2	1,445, 1,495*2	1,465, 1,515*2	1,470, 1,520*2	1,480, 1,530*2	1,470, 1,520*2
	Max. axle weight rating-front		810	810	810	810	810	
	Max. axle weight rating-rear		705, 770*2	705, 770*2	705, 770*2	705, 770*2	705, 770*2	
Seating capacity		5						
Engine	Model No.	4G13			4G92			
	Total displacement ml	1,299			1,597			
Transmission	Model No.	F5M41		F4A41	F5M41	F4A41	F5M41	
	Type	5-speed manual		4-speed automatic	5-speed manual	4-speed automatic	5-speed manual	
Fuel system	Fuel supply system	Electronic controlled multipoint fuel injection						

NOTE

\*1: Vehicles with roof spoiler

\*2: In case of towing

## &lt;SEDAN&gt;

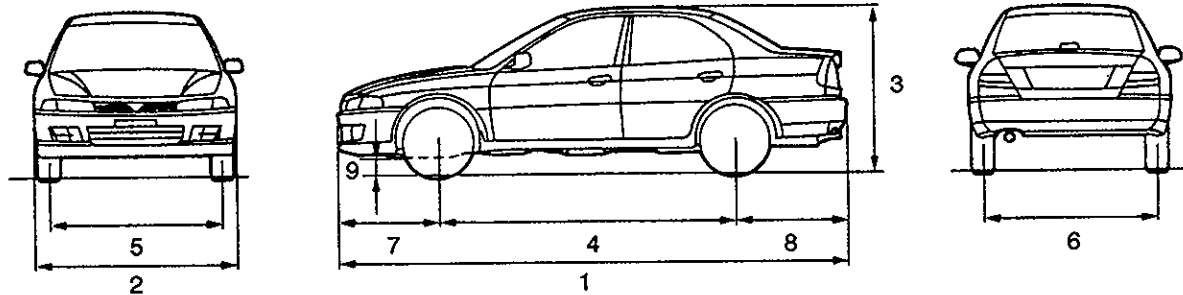

00M0036

Items		CK1A SNDEL6, SNDER6	CK1A SNJEL6, SNJER6	CK1A SRJEL6, SRJER6	CK4A SNJEL6, SNJER6	CK4A SRJEL6, SRJER6
Vehicle dimensions mm	Overall length	1	4,295	4,295	4,295	4,295
	Overall width	2	1,690	1,690	1,690	1,690
	Overall height (unladen)	3	1,395	1,395	1,395	1,395
	Wheelbase	4	2,500	2,500	2,500	2,500
	Track-front	5	1,450	1,450	1,450	1,450
	Track-rear	6	1,460	1,460	1,460	1,460
	Overhang-front	7	845	845	845	845
	Overhang-rear	8	950	950	950	950
	Ground clearance (unladen)	9	150	150	150	150
Vehicle weight kg	Kerb weight		995	1,000	1,020	1,025
	Max. gross vehicle weight rating		1,485, 1,535*	1,485, 1,535*	1,500, 1,550*	1,505, 1,555*
	Max. axle weight rating-front		820	820	820	820
	Max. axle weight rating-rear		720, 790*	720, 790*	720, 790*	720, 790*
Seating capacity		5				
Engine	Model No.	4G13			4G92	
	Total displacement ml	1,299			1,597	
Transmis- sion	Model No.	F5M41		F4A41	F5M41	F4A41
	Type	5-speed manual		4-speed automatic	5-speed manual	4-speed automatic
Fuel system	Fuel supply system	Electronic controlled multipoint fuel injection				

## NOTE

\*: In case of towing

**PRECAUTIONS BEFORE SERVICE**

00100050120

**SUPPLEMENTAL RESTRAINT SYSTEM (SRS), SEAT BELT WITH PRE-TENSIONER**

1. Items to follow when servicing SRS
  - (1) Be sure to read GROUP 52B – Supplemental Restraint System (SRS).  
For safe operations, please follow the directions and heed all warnings.
  - (2) Always use the designated special tools and test equipment.
  - (3) Wait at least 60 seconds after disconnecting the battery cable before doing any further work.  
The SRS system is designed to retain enough voltage to deploy the air bag even after the battery has been disconnected. Serious injury may result from unintended air bag deployment if work is done on the SRS system immediately after the battery cable is disconnected.
  - (4) Never attempt to disassemble or repair the SRS components, (SRS air bag control unit, air bag module and clock spring) and seat belt with pre-tensioner. If faulty, replace it.
  - (5) Warning labels must be heeded when servicing or handling SRS components and seat belt with pre-tensioner. Warning labels are located in the following locations.
    - Sun visor
    - Glove box
    - SRS air bag control unit
    - Steering wheel
    - Steering gear and linkage
    - Air bag module
    - Clock spring
    - Seat belt with pre-tensioner
  - (6) Store components removed from the SRS and seat belt with pre-tensioner in a clean and dry place.  
The air bag module and seat belt with pre-tensioner should be stored on a flat surface and placed so that the pad surface is facing upward.  
Do not place anything on top of it.
  - (7) Be sure to deploy the air bag and seat belt with pre-tensioner before disposing of the air bag module and seat belt with pre-tensioner or disposing of a vehicle equipped with an air bag and seat belt with pre-tensioner. (Refer to GROUP 52B – Air Bag Module and Seat Belt Pre-tensioner Disposal Procedures.)
  - (8) Whenever you finish servicing the SRS and seat belt with pre-tensioner, check the SRS warning lamp operation to make sure that the system functions properly.
2. Observe the following when carrying out operations on places where SRS components and seat belt with pre-tensioner are installed, including operations not directly related to the SRS air bag and seat belt with pre-tensioner.
  - (1) When removing or installing parts do not allow any impact or shock to the SRS components and seat belt with pre-tensioner.
  - (2) SRS components and seat belt with pre-tensioner should not be subjected to heat, so remove the SRS components and seat belt with pre-tensioner before drying or baking the vehicle after painting.
    - SRS air bag control unit, air bag module, clock spring: 93°C or more
    - Seat belt with pre-tensioner 90°C or moreAfter re-installing them, check the SRS warning lamp operation to make sure that the system functions properly.

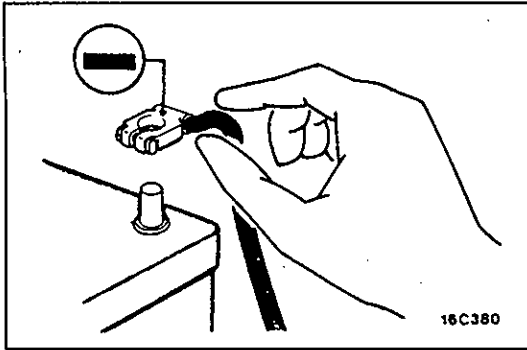

## SERVICING THE ELECTRICAL SYSTEM

Before replacing a component related to the electrical system and before undertaking any repair procedures involving the electrical system, be sure to first disconnect the negative (-) cable from the battery in order to avoid damage caused by short-circuiting.

### Caution

**Before connecting or disconnecting the negative (-) cable, be sure to turn off the ignition switch and the lighting switch.**

**(If this is not done, there is the possibility of semiconductor parts being damaged.)**

## APPLICATION OF ANTI-CORROSION AGENTS AND UNDERCOATS

If oil or grease gets onto the oxygen sensor, it will cause a drop in the performance of the sensor.

Cover the oxygen sensor with a protective cover when applying anti-corrosion agents and undercoats.

## PRE-INSPECTION CONDITION

“Pre-inspection condition” refers to the condition that the vehicle must be in before proper engine inspection can be carried out. If you see the words “Set the vehicle to the pre-inspection condition.” in this manual, it means to set the vehicle to the following condition.

- Engine coolant temperature: 80–90°C
- Lamps, electric cooling fan and all accessories: OFF
- M/T: Neutral
- A/T: P range

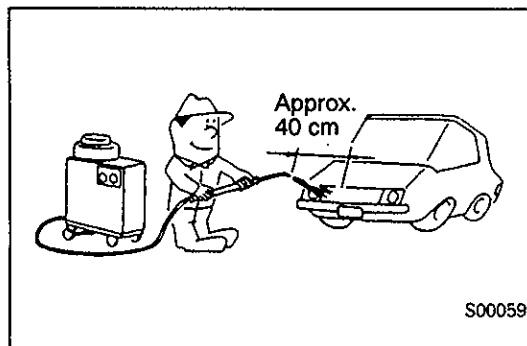

## VEHICLE WASHING

If high-pressure car-washing equipment or steam car-washing equipment is used to wash the vehicle, be sure to note the following information in order to avoid damage to plastic components, etc.

- Spray nozzle distance: Approx. 40 cm or more
- Spray pressure: 3,900 kPa or less
- Spray temperature: 82°C or less
- Time of concentrated spray to one point: within 30 sec.

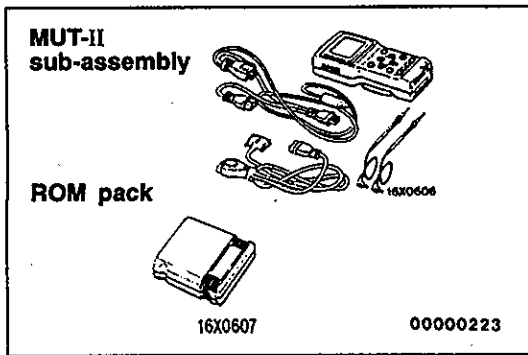
**MUT-II**

Refer to the MUT-II INSTRUCTION MANUAL for instructions on handling the MUT-II.

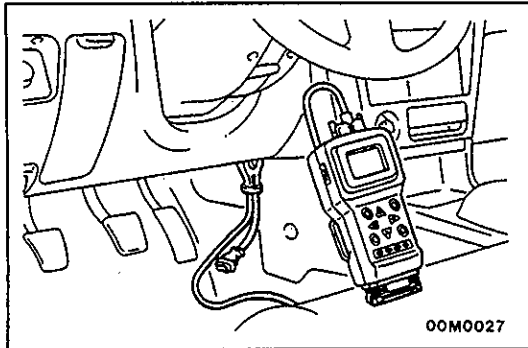

Connect the MUT-II to the diagnosis connector as shown in the illustration.

**Caution**

**Connection and disconnection of the MUT-II should always be made with the ignition switch in the OFF position.**

**IN ORDER TO PREVENT VEHICLES FROM FIRE**

"Improper installation of electrical or fuel related parts could cause a fire. In order to retain the high quality and safety of the vehicle, it is important that any accessories that may be fitted or modifications/repairs that may be carried out which involve the electrical or fuel systems, **MUST** be carried out in accordance with MMC's information/Instructions".

**ENGINE OILS****Health Warning**

Prolonged and repeated contact with mineral oil will result in the removal of natural fats from the skin, leading to dryness, irritation and dermatitis. In addition, used engine oil contains potentially harmful contaminants which may cause skin cancer. Adequate means of skin protection and washing facilities must be provided.

**Recommended Precautions**

The most effective precaution is to adapt working practices which prevent, as far as practicable, the risk of skin contact with mineral oils, for example by using enclosed systems for handling used engine oil and by degreasing components, where practicable, before handling them.

**Other precautions:**

- Avoid prolonged and repeated contact with oils, particularly used engine oils.
- Wear protective clothing, including impervious gloves where practicable.
- Avoid contaminating clothes, particularly underpants, with oil.
- Do not put oily rags in pockets, the use of overalls without pockets will avoid this.
- Do not wear heavily soiled clothing and oil-impregnated foot-wear. Overalls must be cleaned regularly and kept separately from personal clothing.
- Where there is a risk of eye contact, eye protection should be worn, for example, chemical goggles or face shields; in addition an eye wash facility should be provided.
- Obtain First Aid treatment immediately for open cuts and wounds.
- Wash regularly with soap and water to ensure all oil is removed, especially before meals (skin cleansers and nail brushes will help). After cleaning, the application of preparations containing lanolin to replace the natural skin oils is advised.
- Do not use petrol, kerosine, diesel fuel, gas oil, thinners or solvents for cleaning skin.
- Use barrier creams, applying them before each work period, to help the removal of oil from the skin after work.
- If skin disorders develop, obtain medical advice without delay.

# SUPPLEMENTAL RESTRAINT SYSTEM (SRS) AND SEAT BELT WITH PRE-TENSIONER

00100590042

## GENERAL INFORMATION

To improve safety, the SRS and seat belts with pre-tensioner are available as optional parts. These systems enhance collision safety by restraining the front passengers in case of an accident. The SRS works with the pre-tensioner simultaneously when a collision is detected.

The SRS consists of two air bag modules, SRS air bag control unit (SRS-ECU), SRS warning lamp and clock spring. One air bag is located in the centre of the steering wheel and another above the glove box. Each air bag has a folded air bag and an inflator unit. The control unit under the floor console monitors the system and has a safing G sensor and an analog G sensor. The warning lamp on the instrument panel indicates the operational status of the SRS. The clock spring is installed in the steering column.

One air bag is located in the centre of the steering wheel and another above the glove box. Each air

bag has a folded air bag and an inflator unit. The control unit under the floor console monitors the system and has a safing G sensor and an analog G sensor. The warning lamp on the instrument panel indicates the operational status of the SRS. The clock spring is installed in the steering column. The seat belt pre-tensioner is built into the front seat belt retractor. Only authorized service personnel should do work on or around the SRS components and seat belt with pre-tensioner. Those service personnel should read this manual carefully before starting any such work. Extreme care must be used when servicing the SRS to avoid injury to the service personnel (by inadvertent deployment of the air bags or inadvertent operation of the seat belt with pre-tensioner) or the driver (by rendering the SRS or the seat belt with pre-tensioner inoperative).

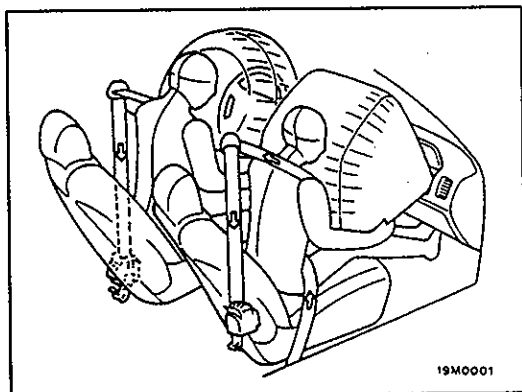

19M0001

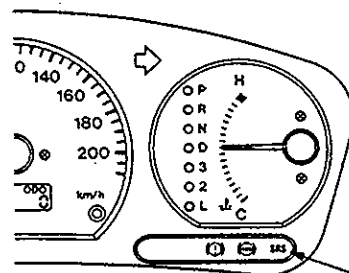

SRS warning lamp

16M0235

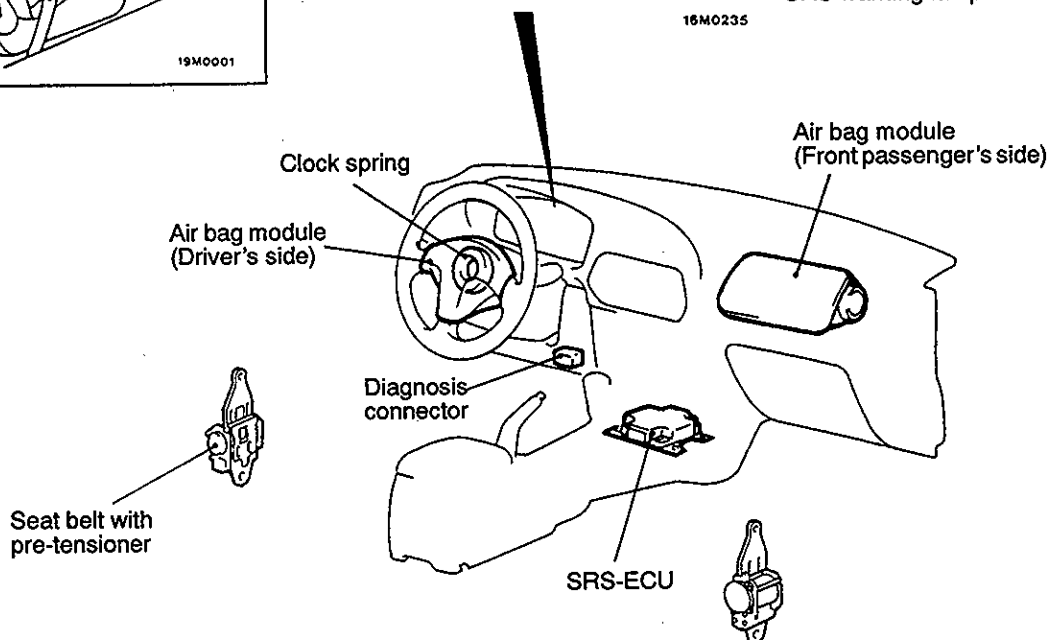

19M0038  
 00004588

SEAT BELT WITH PRE-TENSIONER

The seat belt with pre-tensioner has a pre-tensioner operating mechanism and a G-sensor which detects the force from an impact built into the seat belt retractor.

The G-sensor is a mechanical-type sensor which includes components such as a weight which moves as a result of the impact from a collision, and a spike which strikes a charge and causes it to detonate.

Thus the pre-tensioner is equipped with a safety mechanism to prevent mis-operation during maintenance operations such as removal and installation of the seat belt.

The safety mechanism operates automatically when the retractor top mounting screw is removed during removal of the seat belt.

When the retractor top mounting screw is removed, the force of the spring plate causes the tab at the lower edge of plate (A) to push in the pin of the G-sensor, which prevents the weight inside the G-sensor from moving.

At the same time, the retractor bracket and the top of plate (A) become separated. A stopper is inserted into the gap thus formed by the force from a spring to prevent the tab from being removed from the pin if an outside force is applied to plate (A).

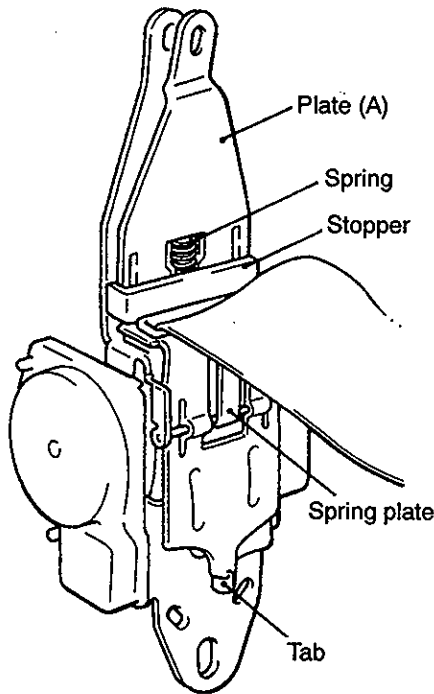

19M0031

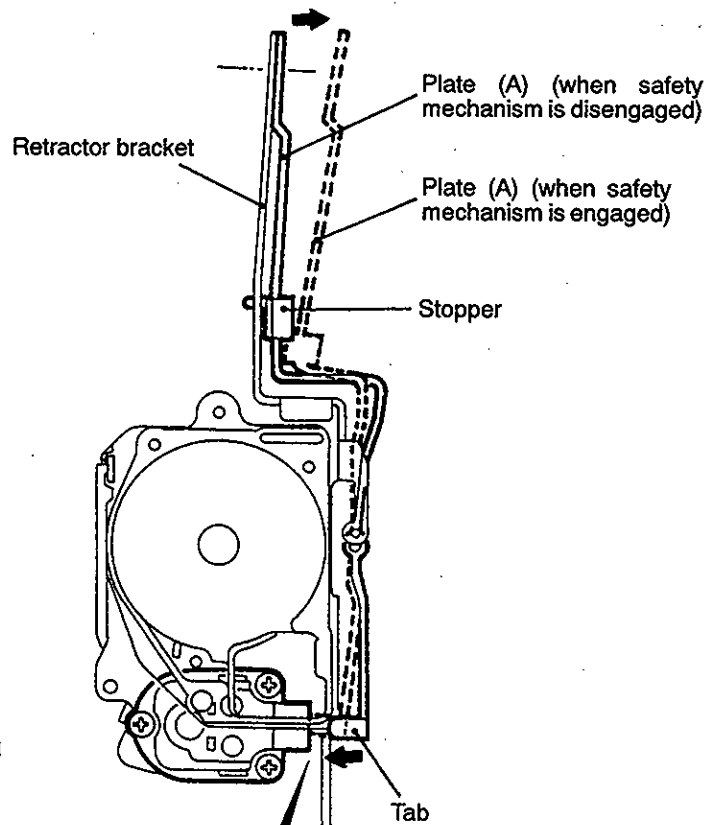

19M0035

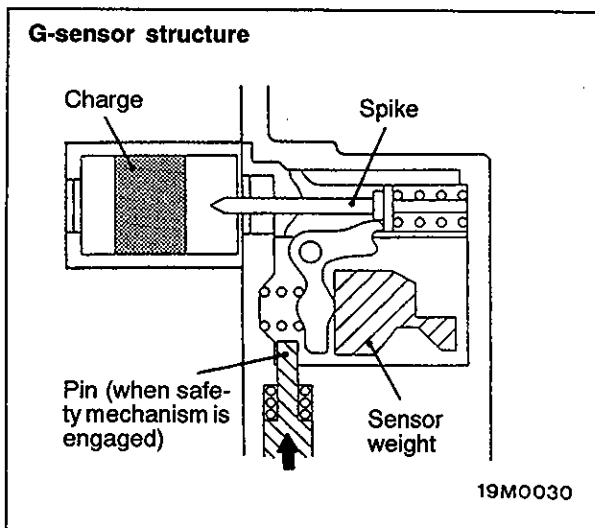

19M0030

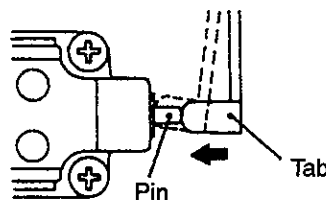

19M0036



**SRS SERVICE PRECAUTIONS**

00100600042

1. In order to avoid injury to yourself or others from accidental deployment of the air bag and accidental operation of the seat belt with pre-tensioner during servicing, read and carefully follow all the precautions and procedures described in this manual.
2. Do not use any electrical test equipment on or near SRS components, except those specified on GROUP 52B.
3. **Never Attempt to Repair the Following Components:**
  - SRS air bag control unit (SRS-ECU)
  - Clock Spring
  - Air Bag Module  
(Driver's side or front passenger's side\*)
  - Seat belt with Pre-tensioner

**NOTE**

\*: Vehicles with front passenger's air bag  
If any of these components are diagnosed as faulty, they should only be replaced, in accordance with the **INDIVIDUAL COMPONENTS SERVICE** procedures in this manual. (Refer to GROUP 52B.)

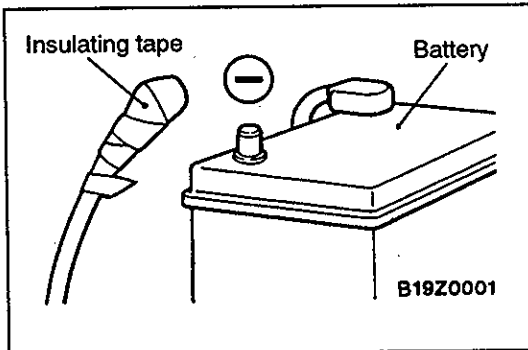

4. **After disconnecting the battery cable, wait 60 seconds or more before proceeding with the following work. The SRS system is designed to retain enough voltage to deploy the air bag for a short time even after the battery has been disconnected, so serious injury may result from unintended air bag deployment if work is done on the SRS system immediately after the battery cables are disconnected.**

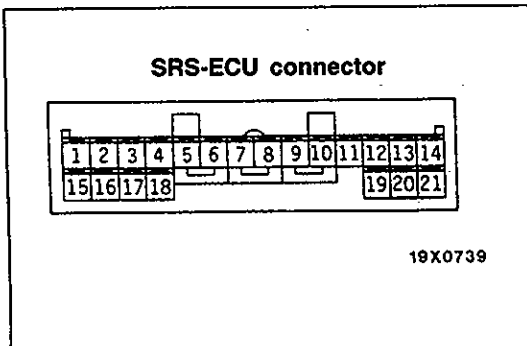

5. Do not attempt to repair the wiring harness connectors of the SRS. If any of the connectors are diagnosed as faulty, replace the wiring harness. If the wires are diagnosed as faulty, replace or repair the wiring harness according to the following table.

SRS-ECU terminal No.	Harness connector (No. of terminals, colour)	Destination of harness	Corrective action
1 to 4	21 pins, yellow	—	—
5		Body wiring harness → Clock spring → Air bag module (Driver's side)	Correct or replace each wiring harness. Replace clock spring.
6			
7*		Body wiring harness → Air bag module (Front passenger's side)	Correct or replace each wiring harness.
8*			
9,10		—	—
11		Body wiring harness → Diagnosis connector	Correct or replace each wiring harness.
12		—	—
13		Body wiring harness → Junction block (fuse No.2)	Correct or replace each wiring harness.
14		Body wiring harness → Junction block (fuse No.4)	
15		Body wiring harness → SRS warning lamp	
16 to 19		—	—
20		Body wiring harness → Earth	Correct or replace body wiring harness.
21			

## NOTE

\*: Vehicles with front passenger's air bag

6. SRS components and seat belt with pre-tensioner should not be subjected to heat, so remove the SRS-ECU, air bag module, clock spring and seat belt with pre-tensioner before drying or baking the vehicle after painting.
  - SRS-ECU, air bag module, clock spring: 93°C or more
  - Seat belt with pre-tensioner: 90°C or more
7. Whenever you finish servicing the SRS, check warning lamp operation to make sure that the system functions properly. (Refer to GROUP 52B – SRS Maintenance.)
8. Make certain that the ignition switch is OFF when the MUT-II is connected or disconnected.
9. If you have any questions about the SRS, please contact your local distributor.

## NOTE

SERIOUS INJURY CAN RESULT FROM UNINTENDED AIR BAG DEPLOYMENT, SO USE ONLY THE PROCEDURES AND EQUIPMENT SPECIFIED IN THIS MANUAL.

# SUPPORT LOCATIONS FOR LIFTING AND JACKING

00100070041

## Caution

Do not support the vehicles at locations other than specified supporting points. If do so, this will cause damage, etc.

## SUPPORT POSITIONS FOR A GARAGE JACK AND AXLE STANDS

### GARAGE JACK

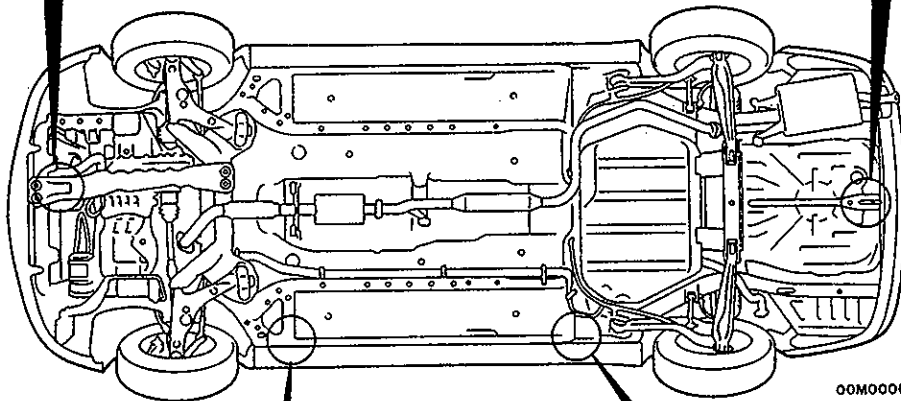
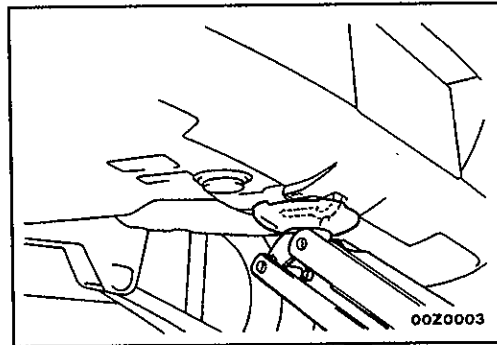
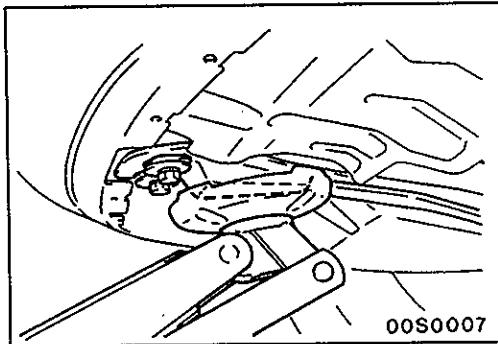

### AXLE STANDS

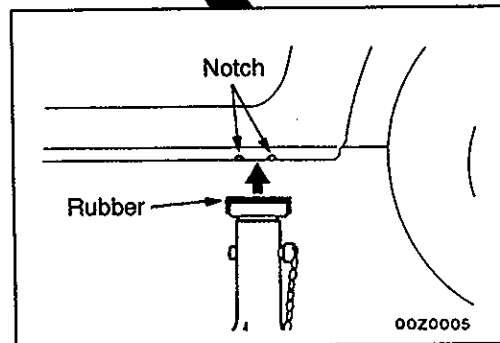
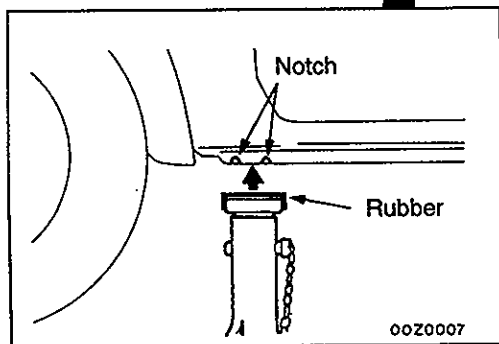

**SUPPORT POSITIONS FOR A SINGLE-POST LIFT OR DOUBLE-POST LIFT**

**Caution**

When service procedures require removing rear suspension, spare tyre and rear bumper, place additional weight on rear end of vehicle or anchor vehicle to hoist to prevent tipping of centre of gravity changes.

**DOUBLE-POST LIFT**

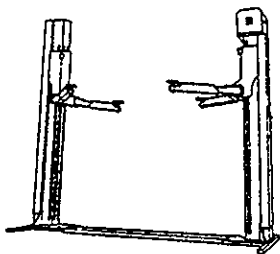

00E610

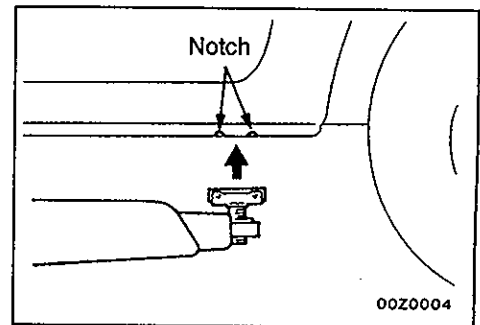
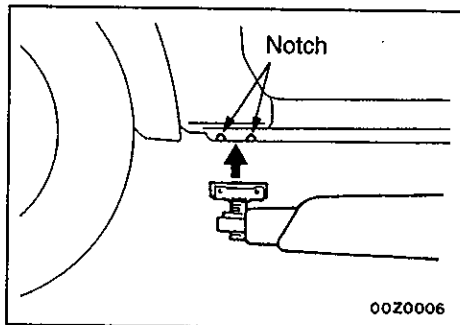

**SINGLE-POST LIFT**

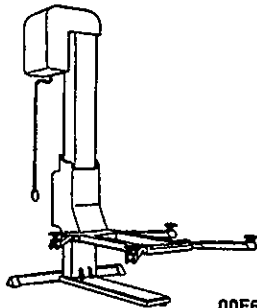

00E609

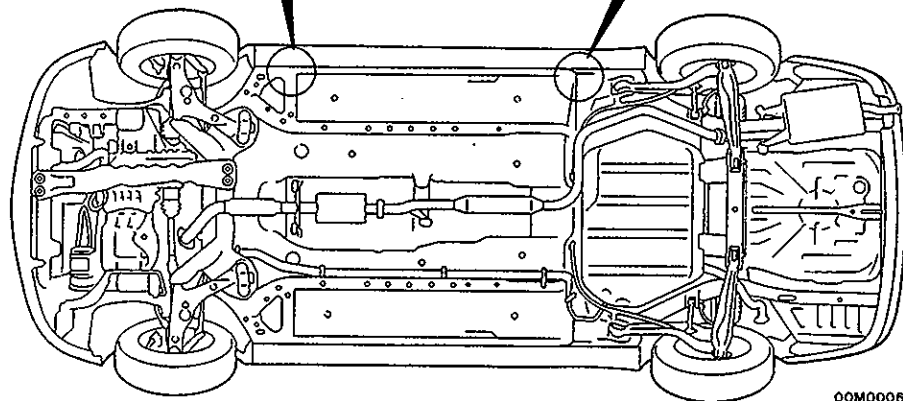

00M0006

0000489

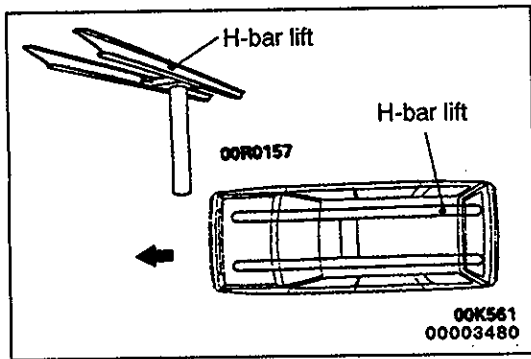

### SUPPORT POSITIONS AND SUPPORT METHOD FOR AN H-BAR LIFT

**Caution**

When service procedures require removing rear suspension, fuel tank, spare tyre and rear bumper, place additional weight on rear end of vehicle or anchor vehicle to hoist to prevent tipping of centre of gravity changes.

When H-bar lift is used to lift up vehicles, use of metallic attachment attached to the H-bar lift may cause damage to the suspension arm etc. Therefore, lift up the vehicle by the following procedure.

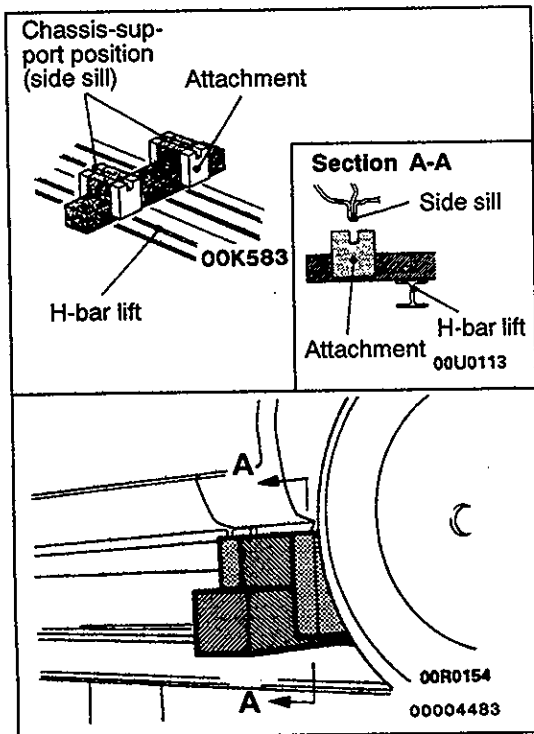

1. Place the vehicle on the H-bar lift (same direction).
2. Place attachments on the H-bar lift at the designated chassis-support positions. When making the attachments, refer to the section concerning making them.

**Caution**

If support is at any location other than the designated positions, the body or suspension might be deformed or otherwise damaged, so care should be taken to support only at the correct (designated) positions.

3. Raise the H-bar lift to the height at which the vehicle is slightly raised and check to be sure that the vehicle is correctly and sufficiently secured; then raise the vehicle.

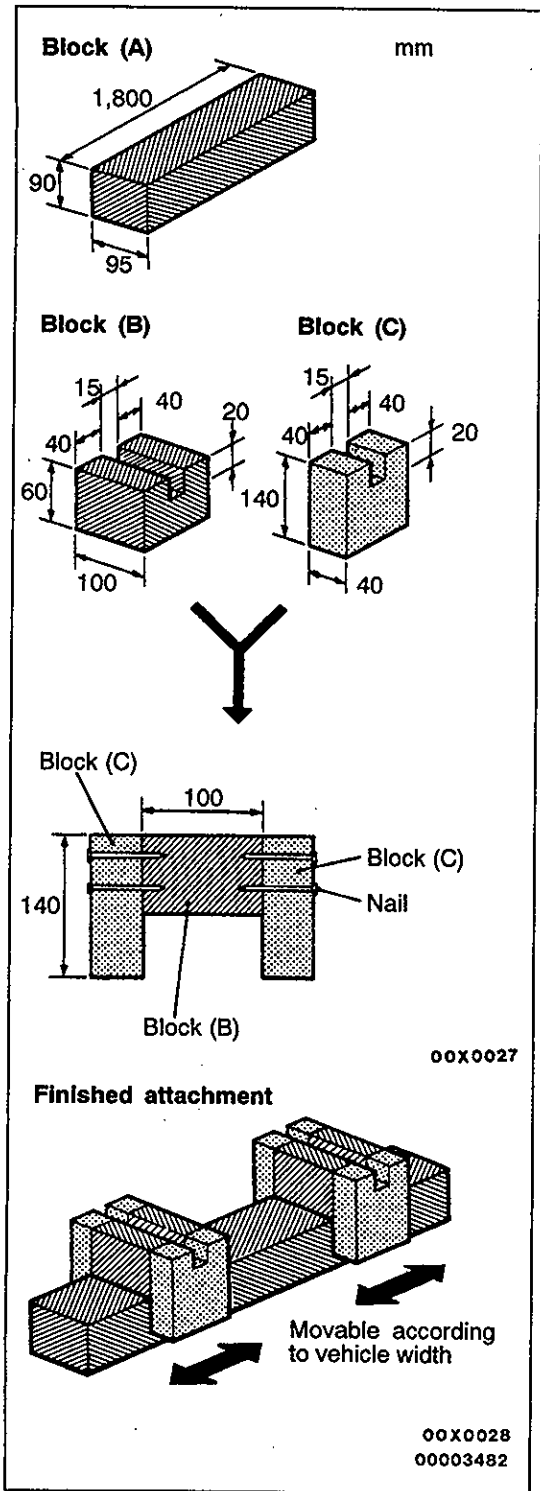

**PREPARATION OF "ATTACHMENTS"**

1. Prepare the blocks (wooden) and nails as shown in the figure.

Item	Dimensions mm	Quantity
Block (A)	90 x 95 x 1,800	2
Block (B)	60 x 100 x 95	4
Block (C)	140 x 40 x 95	8
Nail	70 or more	32

**Caution**

The wood selected for the blocks must be hard.

- For the (B) blocks and (C) blocks, use a saw and chisel or similar tool to make grooves of the dimensions shown in the figure.
- Make four "ATTACHMENTS" such as shown in the figure nailing (B) and (C) blocks so that each (B) blocks is sandwiches between (C) blocks.

**STANDARD PART/TIGHTENING-TORQUE TABLE**

00100110033

Each torque value in the table is a standard value for tightening under the following conditions.

- (1) Bolts, nuts and washers are all made of steel and plated with zinc.
- (2) The threads and bearing surface of bolts and nuts are all in dry condition.

The values in the table are not applicable:

- (1) If toothed washers are inserted.
- (2) If plastic parts are fastened.
- (3) If bolts are tightened to plastic or die-cast inserted nuts.
- (4) If self-tapping screws or self-locking nuts are used.

**Standard bolt and nut tightening torque**

Thread size		Torque Nm		
Bolt nominal diameter (mm)	Pitch (mm)	Head mark "4"	Head mark "7"	Head mark "8"
M5	0.8	2.5	4.9	5.9
M6	1.0	4.9	8.8	9.8
M8	1.25	12	22	25
M10	1.25	24	44	52
M12	1.25	41	81	96
M14	1.5	72	137	157
M16	1.5	111	206	235
M18	1.5	167	304	343
M20	1.5	226	412	481
M22	1.5	304	559	647
M24	1.5	392	735	853

**Flange bolt and nut tightening torque**

Thread size		Torque Nm		
Bolt nominal diameter (mm)	Pitch (mm)	Head mark "4"	Head mark "7"	Head mark "8"
M6	1.0	4.9	9.8	12
M8	1.25	13	24	28
M10	1.25	26	49	57
M10	1.5	24	44	54
M12	1.25	46	93	103
M12	1.75	42	81	96

---

**NOTES**