

REAR AXLE

CONTENTS

2710900088

GENERAL INFORMATION	2	ON-VEHICLE SERVICE	3
SERVICE SPECIFICATIONS	2	Wheel Bearing Axial Play Check	3
SPECIAL TOOLS	2	Rear Hub Rotary-Sliding Resistance Check	3
		Hub Bolt Replacement	3
		REAR AXLE HUB	4



GENERAL INFORMATION

27100010095

The wheel bearing adopted is a unit ball bearing (double-row angular contact ball bearing), which uses the inside surface of the rear hub as the bearing outer race to reduce weight and size. This bearing has excellent service efficiency since

it is so constructed that appropriate bearing preload is available just by tightening the lock nut to the specified torque.

On vehicles with ABS, the rotor for detecting the wheel speed is installed on the rear hub.

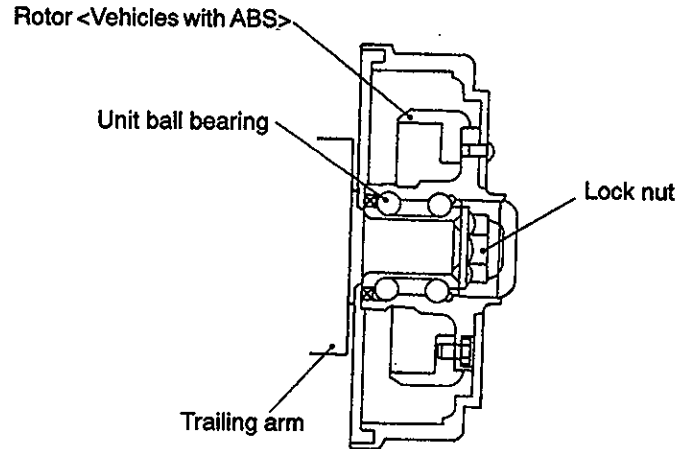

A11M0001



SERVICE SPECIFICATIONS

27100030107

Items	Standard value	Limit
Clearance of the rear speed sensor's pole piece and rotor <Vehicles with ABS> mm	0.1 – 2.0	—
Wheel bearing axial play mm	—	0.05
Wheel bearing rotary-sliding resistance N	—	19 or less

SPECIAL TOOLS

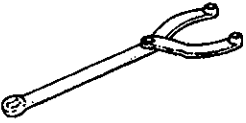
27100060090

Tool	Number	Name	Use
	MB990767	End yoke holder	Fixing of the hub
 11H0072	MB991618	Hub bolt remover	Removal of the hub bolt

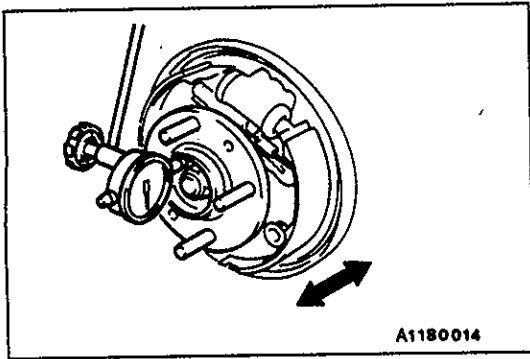

ON-VEHICLE SERVICE

27100090082

WHEEL BEARING AXIAL PLAY CHECK

1. Remove the brake drum.
2. Check the bearing's axial play.
Place a dial gauge against the hub surface; then move the hub in the axial direction and check whether or not there is axial play.

Limit: 0.05 mm

3. If the axial play exceeds the limit, the flange nut should be tightened to the specified torque (172 Nm) and check the axial play again.
4. Replace the rear hub assembly if an adjustment cannot be made to within the limit.

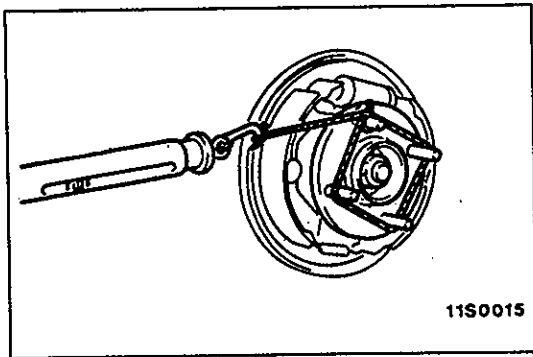

REAR HUB ROTARY-SLIDING RESISTANCE CHECK

27100110085

1. Remove the brake drum.
2. After turning the hub a few times to seat the bearing, wind a rope around the hub bolt and turn the hub by pulling at a 90° angle with a spring balance. Measure to determine whether or not the rotary-sliding resistance of the rear hub is at the limit value.

Limit: 19 N or less

3. If the limit value is exceeded, loosen the flange nut and then tighten it to the specified torque (172 Nm) and check the rear hub rotary sliding resistance again.
4. Replace the rear hub assembly if an adjustment cannot be made to within the limit.

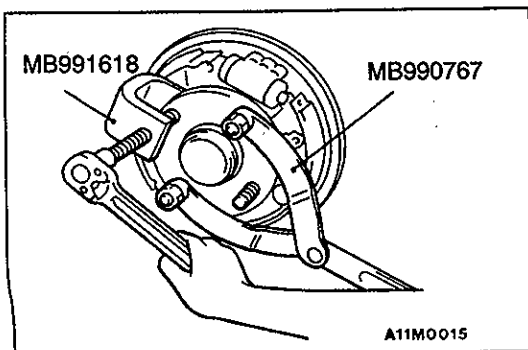

HUB BOLT REPLACEMENT

27100100082

<VEHICLES WITHOUT ABS>

1. Remove the brake drum.
2. Use the special tools to remove the hub bolts.

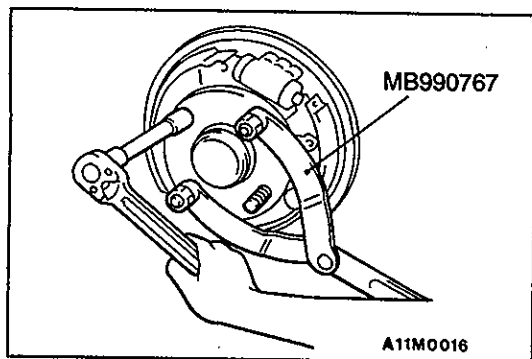

- Use the wheel nuts to securely install the new hub bolts, while being careful of the hub bolts and hub.

REAR AXLE HUB REMOVAL AND INSTALLATION

27100200126

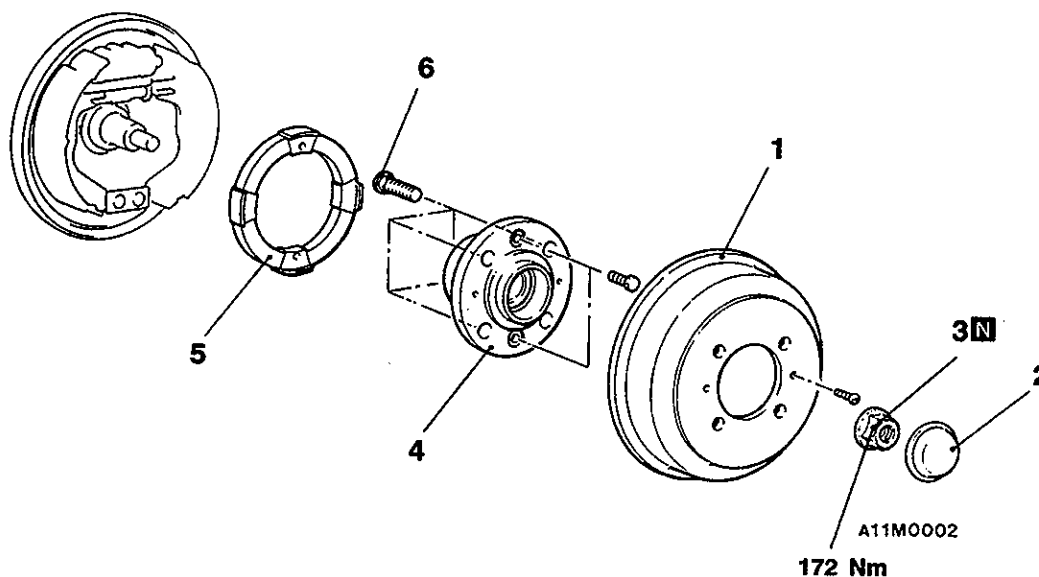

Removal steps

- Brake drum
- Hub cap
- Flange nut
- Rear hub assembly
- Rotor <Vehicles with ABS>
- Hub bolt



Caution

- The rear hub unit bearing should not be dismantled.

When removing the rear hub assembly, the wheel bearing inner race may be left at the spindle side.

In this case, always replace the rear hub assembly, otherwise the hub will damage the oil seal, causing oil leaks or excessive play.

- Care must be taken not to scratch or otherwise damage the teeth of the rotor. The rotor must never be dropped. If the teeth of the rotor are chipped, resulting in a deformation of the rotor, it will not be able to accurately detect the wheel rotation speed, and the system will not function normally.

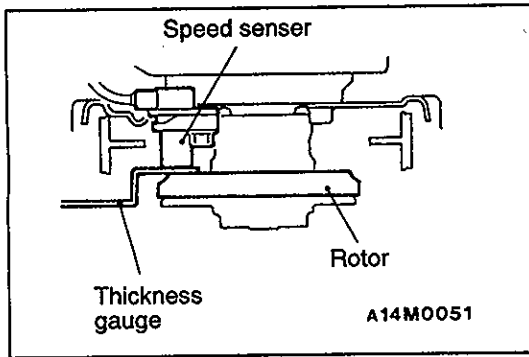

INSTALLATION SERVICE POINT

►A◄ REAR HUB ASSEMBLY INSTALLATION <VEHICLES WITH ABS>

Caution

Be careful that the pole piece at the end of the speed sensor and the rotor teeth do not become damaged by striking them against the metal parts.

Insert a thickness gauge into the space between the speed sensor's pole piece and the rotor's toothed surface, and then tighten the speed sensor bracket at the position where the clearance is the standard value all around.

Standard value: 0.1 – 2.0 mm

INSPECTION

27100210075

- Check the oil seal for crack or damage.
- Check the rear hub unit bearing for wear or damage.
- Check the rear rotor for chipped teeth.

NOTES