GENERAL

CONTENTS

00109000904

GENERAL <BODY AND CHASSIS>	00
GENERAL <ELECTRICAL>	00E

GENERAL <BODY AND CHASSIS>

CONTENTS

00109001172

GENERAL DATA AND SPECIFICATIONS ..	24	Engine Coolant	44
HOW TO USE THIS MANUAL	3	Engine Oil	39
Definition of Terms	3	Engine Oil Filter	40
Explanation of Manual Contents	4	Evaporative Emission Control System	33
Model Indications	3	Exhaust System	51
Maintenance, Repair and Servicing Explanations	3	Fuel Hoses	32
Special Tool Note	3	Fuel System	32
Tightening Torque Indication	3	Ignition Cables	33
HOW TO USE TROUBLESHOOTING/INSPECTION SERVICE POINTS	6	Manual Transaxle	41
Connector Inspection Service Points	10	Rear Drum Brake Linings and Rear Wheel Cylinders	45
Connector Measurement Service Points	9	Spark Plugs	33
How to Cope with Intermittent Malfunctions	11	SRS Air Bag System	47
How to Use the Inspection Procedures	8	Timing Belt	34
Inspection Service Points for a Blown Fuse	12	PRECAUTIONS BEFORE SERVICE	19
Troubleshooting Contents	6	RECOMMENDED LUBRICANT AND LUBRICANT CAPACITY TABLE	28
LUBRICATION AND MAINTENANCE	27	SCHEDULED MAINTENANCE TABLE	31
MAIN SEALANT AND ADHESIVE TABLE ..	52	TIGHTENING TORQUE	26
MAINTENANCE SERVICE	32	TOWING AND HOISTING	21
Air Cleaner Element	32	VEHICLE IDENTIFICATION	13
Automatic Transaxle	41	Engine Model Stamping	16
Ball Joint and Steering Linkage Seals	46	Theft Protection	16
Brake Hoses	46	Vehicle Identification Code Chart Plate	13
Disc Brake Pads	45	Vehicle Identification Number List	14
Distributor Cap and Rotor	34	Vehicle Identification Number Location	13
Drive Belt	35	Vehicle Information Code Plate	15
Drive Shaft Boots	46	Vehicle Safety Certification Label	15

HOW TO USE THIS MANUAL

00100010234

MAINTENANCE, REPAIR AND SERVICING EXPLANATIONS

This manual provides explanations, etc. concerning procedures for the inspection, maintenance, repair and servicing of the subject model. Unless otherwise specified, each service procedure covers all models. Procedures covering specific models are identified by the model codes, or similar designation (engine type, transaxle type, etc.). A description of these designations is covered in this manual under "VEHICLE IDENTIFICATION".

ON-VEHICLE SERVICE

"On-vehicle Service" are procedures for performing inspections and adjustments of particularly important locations with regard to the construction and for maintenance and servicing, but other inspections (for looseness, play, cracking, damage, etc.) must also be performed.

SERVICE PROCEDURES

The service steps are arranged in numerical order. Attention must be paid in performing vehicle service are described in detail in SERVICE POINTS.

DEFINITION OF TERMS

STANDARD VALUE

Indicates the value used as the standard for judging the quality of a part or assembly on inspection or the value to which the part or assembly is corrected and adjusted. It is given by tolerance.

LIMIT

Shows the standard for judging the quality of a part or assembly on inspection and means the maximum or minimum value within which the part or

assembly must be kept functionally or in strength. It is a value established outside the range of standard value.

REFERENCE VALUE

Indicates the adjustment value prior to starting the work (presented in order to facilitate assembly and adjustment procedures, and so they can be completed in a shorter time).

CAUTION

Indicates the presentation of information particularly vital to the worker during the performance of maintenance and servicing procedures in order to avoid the possibility of injury to the worker, or damage to component parts, or a reduction of component or vehicle function or performance, etc.

TIGHTENING TORQUE INDICATION

The tightening torque shown in this manual is a basic value with a tolerance of $\pm 10\%$ except the following cases when the upper and lower limits of tightening torque are given.

- (1) The tolerance of the basic value is within $\pm 10\%$.
- (2) Special bolts or the like are in use.
- (3) Special tightening methods are used.

SPECIAL TOOL NOTE

Only MMC special tool part numbers are called out in the repair sections of this manual. Please refer to the special tool cross reference chart, which is located in the service manual at the beginning of each group, for a cross reference from the MMC special tool number to the special tool number that is available in your market.

MODEL INDICATIONS

The following abbreviations are used in this manual for classification of model types.

M/T : Indicates the manual transaxle, or models equipped with the manual transaxle.

A/T : Indicates the automatic transaxle, or models equipped with the automatic transaxle.

EXPLANATION OF MANUAL CONTENTS

Indicates procedures to be performed before the work in that section is started, and procedures to be performed after the work in that section is finished.

Component Diagram

A diagram of the component parts is provided near the front of each section in order to give the reader a better understanding of the installed condition of component parts.

Indicates (by symbols) where lubrication is necessary.

Maintenance and Servicing Procedures

The numbers provided within the diagram indicate the sequence for maintenance and servicing procedures.

- Removal steps :
The part designation number corresponds to the number in the illustration to indicate removal steps.
- Disassembly steps :
The part designation number corresponds to the number in the illustration to indicate disassembly steps.

- Installation steps :
Specified in case installation is impossible in reverse order of removal steps. Omitted if installation is possible in reverse order of removal steps.
- Reassembly steps :
Specified in case reassembly is impossible in reverse order of disassembly steps. Omitted if reassembly is possible in reverse order of disassembly steps.

Classifications of Major Maintenance / Service points





When there are major points relative to maintenance and servicing procedures (such as essential maintenance and service points, maintenance and service standard values, information regarding the use of special tools, etc.), these are arranged together as major maintenance and service points and explained in detail.

◀A▶ : Indicates that there are essential points for removal or disassembly.

▶A◀ : Indicates that there are essential points for installation or reassembly.

Symbols for Lubrication, Sealants and Adhesives

Information concerning the locations for lubrication and for application of sealants and adhesives is provided, by using symbols, in the diagram of component parts or on the page following the component parts page, and explained.

-  : Grease (multipurpose grease unless there is a brand or type specified)
-  : Sealant or adhesive
-  : Brake fluid or automatic transmission fluid
-  : Engine oil, gear oil or air conditioning compressor oil
-  : Adhesive tape or butyl rubber tape

Indicates the group title.

Indicates the section title.

Indicates the group number.

Indicates the page number.

STEERING - Power Steering Gear Box

37A-23

POWER STEERING GEAR BOX
REMOVAL AND INSTALLATION

11 00000526

- Pre-removal Operation**
- Power Steering Fluid Draining (Refer to P37A-15.)
 - Stabilizer Bar Removal (Refer to GROUP 33A - Stabilizer Bar)

Denotes tightening torque. If there is no indication of tightening torque, refer to TIGHTENING TORQUE.

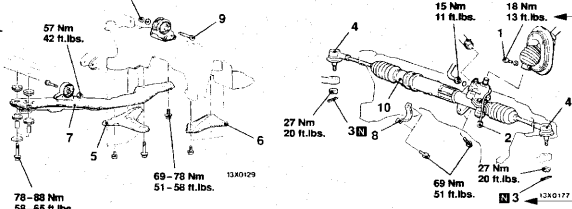

N denotes a non-reusable part.

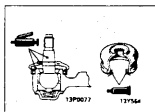

Sealant: 3M ATD Part No. 8663 or equivalent



Repair kit or set parts are shown. (Only very frequently used parts are shown.)

Removal steps

1. Joint assembly and gear box connecting bolt
2. Solenoid valve connector <Vehicles with EPS>
3. Cotter pin
4. Connection for tie-rod end and knuckle
5. Stay (L.H.)
6. Stay (R.H.)
7. Center member assembly
8. Clamp
9. Bolt
10. Gear box assembly

REMOVAL SERVICE POINTS

TIE-ROD END DISCONNECTION

- Caution**
1. Be sure to tie the cord of the special tool to the nearby part.
 2. Loosen the nut but do not remove it.

Operating procedures, cautions, etc. on removal, installation, disassembly and reassembly are described.

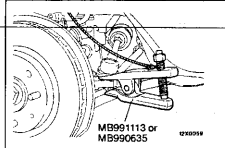

FOG LIGHT RELAY CONTINUITY CHECK

Battery voltage	Terminal			
	1	3	4	5
Power is not supplied	○	○	○	○
Power is supplied	⊕	⊕	⊕	⊕

○—○ indicates that there is continuity between the terminals.
⊕—○ indicates terminals to which battery voltage is applied.

37A-28

STEERING - Power Steering Gear Box

LUBRICATION AND SEALING POINTS

<Conventional power steering gear box>

The title of the page (following the page on which the diagram of Component parts is presented) indicating the locations of lubrication and sealing procedures.

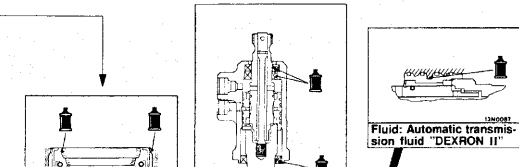

HOW TO USE TROUBLESHOOTING/INSPECTION SERVICE POINTS

00100020121

Troubleshooting of electronic control systems for which the scan tool can be used follows the basic outline described below. Furthermore, even in systems for which the scan tool cannot be used, part of these systems still follow this outline.

TROUBLESHOOTING CONTENTS**1. STANDARD FLOW OF DIAGNOSTIC TROUBLESHOOTING**

The main procedures for diagnostic troubleshooting are shown.

2. SYSTEM OPERATION AND SYMPTOM VERIFICATION TESTS

If verification of the trouble symptoms is difficult, procedures for checking operation and verifying trouble symptoms are shown.

3. DIAGNOSTIC FUNCTION

The following diagnostic functions are shown.

- Method of reading diagnostic trouble codes
- Method of erasing diagnostic trouble codes
- Input inspection service points

4. INSPECTION CHART FOR DIAGNOSTIC TROUBLE CODES**5. INSPECTION PROCEDURE FOR DIAGNOSTIC TROUBLE CODES**

Indicates the inspection procedures corresponding to each diagnostic trouble code. (Refer to the next page on how to read the inspection procedures.)

6. INSPECTION CHART FOR TROUBLE SYMPTOMS

If there are trouble symptoms, even though the results of inspection using the scan tool show that all diagnostic trouble codes are normal, inspection procedures for each trouble symptom will be found by means of this chart.

7. INSPECTION PROCEDURE FOR DIAGNOSTIC SYMPTOM

Indicates the inspection procedures corresponding to each trouble symptoms classified in the Inspection Chart for Trouble Symptoms. (Refer to the next page on how to read the inspection procedures.)

8. SERVICE DATA REFERENCE TABLE

Inspection items and normal judgement values have been provided in this chart as reference information.

9. CHECK AT ECU TERMINALS

Terminal numbers for the ECU connectors, inspection items and standard values have been provided in this chart as reference information.

Terminal Voltage Checks

1. Connect a needle-nosed wire probe or paper clip to a voltmeter probe.
2. Insert the needle-nosed wire probe into each of the ECU connector terminals from the wire side, and measure the voltage while referring to the check chart.

NOTE

1. Measure voltage with the ECU connectors connected.
2. You may find it convenient to pull out the ECU to make it easier to reach the connector terminals.
3. Checks don't have to be carried out in the order given in the chart.

Caution

Short-circuiting the positive (+) probe between a connector terminal and ground could damage the vehicle wiring, the sensor, the ECU, or all three.

Use care to prevent this !

3. If voltage readings differ from Normal Condition values, check related sensors, actuators, and wiring, then replace or repair.

4. After repair or replacement, recheck with the voltmeter to confirm that the repair has corrected the problem.

Terminal Resistance and Continuity Checks

1. Turn the ignition switch to "OFF".
2. Disconnect the ECU connector.
3. Measure the resistance and check for continuity between the terminals of the ECU harness-side connector while referring to the check chart.

NOTE

Checks don't have to be carried out in the order given in the chart.

Caution

If resistance and continuity checks are performed on the wrong terminals, damage to the vehicle wiring, sensors, ECU, and/or ohmmeter may occur.

Use care to prevent this!

4. If the ohmmeter shows any deviation from the Normal Condition value, check the corresponding sensor, actuator and related electrical wiring, then repair or replace.
5. After repair or replacement, recheck with the ohmmeter to confirm that the repair has corrected the problem.

10. INSPECTION PROCEDURES USING AN OSCILLOSCOPE

When there are inspection procedures using an oscilloscope, these are listed here.

HOW TO USE THE INSPECTION PROCEDURES

The causes of many problems occurring in electronic circuitry are generally the connectors, components, the ECU and the harnesses between connectors, in that order. These inspection procedures follow this order. They first try to discover a problem with a connector or a defective component.

CHECKING PROCEDURE 4

- Indicator does not turn on or off even if control mode switch is pressed.
- Indicator which should not be illuminated is illuminated.

Probable cause

In the above cases, the ECS switch circuit is defective or the indicator circuit is defective.

1. Indicates inspection carried out using the scan tool.
Indicates the operation and inspection procedures.
Indicates the OK judgement conditions.

Scan Tool Data List

17 Control mode selection switch
OK: Voltage changes between approx. 0V → approx. 2.5V → approx. 5V when the switch is operated.

OK

2. Detailed inspection procedures (methods) such as component inspection and circuit inspection are listed on a separate page, and are given here for reference.

ECU switch component inspection (Refer to P.3-44.)

NG

3. Indicates voltage and resistance to be measured at a particular connector. (Refer to "Connector Measurement Service Points".) The connector position can be located in the wiring diagram in Volume -2 manual by means of this symbol. Indicates operation and inspection procedures, inspection terminals and inspection conditions. Indicates the OK judgement conditions.

Measure at switch connector A-44

- Disconnect the connector, and measure at the harness side.
- Voltage between terminal 6 - earth and terminal 8 - ground
OK: Approx. 5V

OK

4. Inspect the contact condition at each connector terminal. (Refer to "Connector Inspection Service Points".) The connector position can be located in the wiring diagram in Volume -2 manual by means of this symbol.
Caution
After carrying out connector inspection, always be sure to reconnect the connector as it was before.

Check the following connector. A-44

OK

Check trouble symptom.

OK

5. Confirm that there are trouble symptoms. If trouble symptoms have disappeared, the connector may have been inserted incorrectly and the trouble symptom may have disappeared during inspection. If it seems that trouble symptoms still remain, proceed to the next stage of instructions.

Replace the ECS-ECU.

6. If trouble symptoms still remain up to this stage, there is a possibility that there is an open or short circuit in the harness between the connectors, so check the harness. Alternatively, the cause may be a defective ECU, so try replacing the ECU and check if the trouble symptom disappears.

HARNESS INSPECTION

Check for an open or short circuit in the harness between the terminals which were defective according to the connector measurements. Carry out this inspection while referring to Volume 2 Electrical manual. Here, "Check harness between power supply and terminal xx" also includes checking for blown fuses. For inspection service points when there is a blown fuse, refer to "Inspection Service Points for a Blown Fuse".

MEASURES TO TAKE AFTER REPLACING THE ECU

If the trouble symptoms have not disappeared even after replacing the ECU, repeat the inspection procedure from the beginning.

CONNECTOR MEASUREMENT SERVICE POINTS

Turn the ignition switch to OFF when connecting and disconnecting the connectors. Turn the ignition switch to ON when measuring if there are no instructions to the contrary.

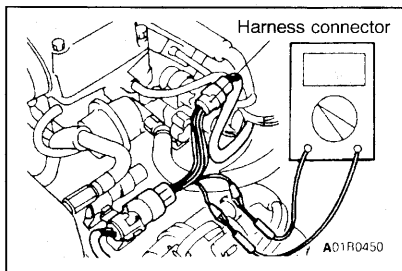
**IF INSPECTING WITH THE CONNECTOR CONNECTED (WITH CIRCUIT IN A CONDITION OF CONTINUITY)****Waterproof Connectors**

Be sure to use the special tool (harness connector). Never insert a test probe from the harness side, as this will reduce the waterproof performance and result in corrosion.

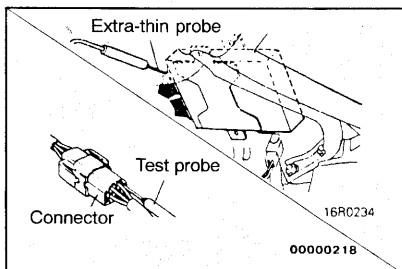
**Ordinary (non-waterproof) Connectors**

Check by inserting the test probe from the harness side. Note that if the connector (control unit, etc.) is too small to permit insertion of the test probe, it should not be forced; use a special tool (the extra-thin probe in the harness set for checking) for this purpose.

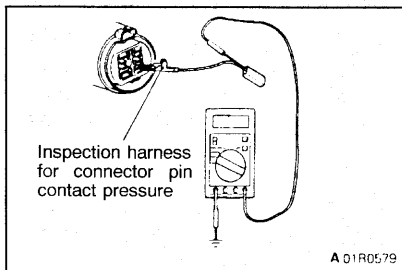
**IF INSPECTING WITH THE CONNECTOR DISCONNECTED****<When Inspecting a Female Pin>**

Use the special tool (inspection harness for connector pin contact pressure in the harness set for inspection). The inspection harness for connector pin contact pressure should be used. The test probe should never be forcibly inserted, as it may cause a defective contact.

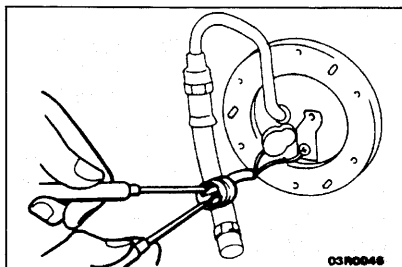
**<When Inspecting a Male Pin>**

Touch the pin directly with the test bar.

Caution

At this time, be careful not to short the connector pins with the test probes. To do so may damage the circuits inside the ECU.

Connector disconnected or improperly connected

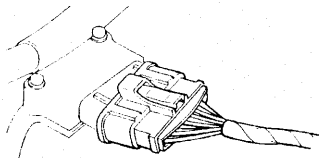

16S0256

Defective connector contact

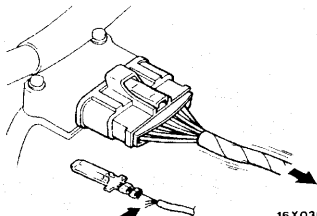

Harness wire breakage at terminal section

16X0369

Low contact pressure

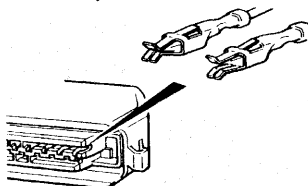

16S0254
00000219

CONNECTOR INSPECTION SERVICE POINTS VISUAL INSPECTION

- Connector is disconnected or improperly connected
- Connector pins are pulled out
- Due to harness tension at terminal section
- Low contact pressure between male and female terminals
- Low connection pressure due to rusted terminals or foreign matter lodged in terminals

CONNECTOR PIN INSPECTION

If the connector pin stopper is damaged, the terminal connections (male and female pins) will not be perfect even when the connector body is connected, because the pins may pull out of the back side of the connector. Therefore, gently pull the wires one by one to make sure that no pins pull out of the connector.

CONNECTOR ENGAGEMENT INSPECTION

Use the special tool (connector pin connection pressure inspection harness of the inspection harness set) to inspect the engagement of the male pins and female pins. [Pin drawing force : 1 N (.2 lbs.) or more]

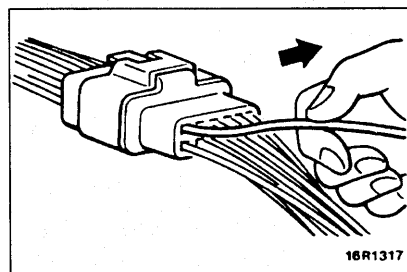

16R1317

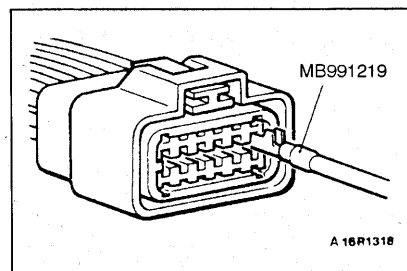

MB991219

A 16R1318

HOW TO COPE WITH INTERMITTENT MALFUNCTIONS

Most intermittent malfunctions occur under certain conditions. If those conditions can be identified, the cause will be easier to find.

TO COPE WITH INTERMITTENT MALFUNCTION;

1. Ask the customer about the malfunction

Ask what it feels like, what it sounds like, etc. Then ask about driving conditions, weather, frequency of occurrence, and so on.

2. Determine the conditions from the customer's responses

Typically, almost all intermittent malfunctions occur from conditions like vibration, temperature and/or moisture change, poor connections. From the customer's replies, it should be reasoned which condition is influenced.

3. Use simulation test

In the cases of vibration or poor connections, use the simulation tests below to attempt to

duplicate the customer's complaint. Determine the most likely circuit(s) and perform the simulation tests on the connectors and parts of that circuit(s). Be sure to use the inspection procedures provided for diagnostic trouble codes and trouble symptoms.

For temperature and/or moisture conditions related intermittent malfunctions, using common sense, try to change the conditions of the suspected circuit components, then use the simulation tests below.

4. Verify the intermittent malfunction is eliminated

Repair the malfunctioning part and try to duplicate the condition(s) again to verify the intermittent malfunction has been eliminated.

SIMULATION TESTS

For these simulation tests, shake, then gently bend, pull, and twist the wiring of each of these examples to duplicate the intermittent malfunction.

- Shake the connector up-and-down, and right-and-left.
- Shake the wiring harness up-and-down, and right-and-left.
- Vibrate the part or sensor.

NOTE

In case of difficulty in finding the cause of the intermittent malfunction, the data recorder function in the scan tool is effective.

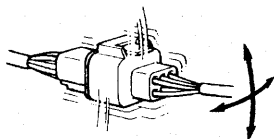

16S0253

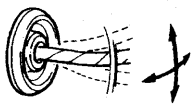

16S0250

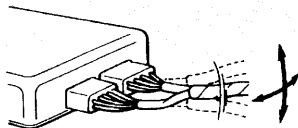

16S0252

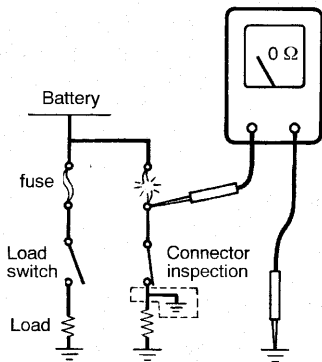

16X0370

INSPECTION SERVICE POINTS FOR A BLOWN FUSE

Remove the fuse and measure the resistance between the load side of the fuse and ground. Set the switches of all circuits which are connected to this fuse to a condition of continuity. If the resistance is almost 0Ω at this time, there is a short somewhere between these switches and the load. If the resistance is not 0Ω , there is no short at the present time, but a momentary short has probably caused the fuse to blow.

The main causes of a short circuit are the following.

- Harness being clamped by the vehicle body
- Damage to the outer casing of the harness due to wear or heat
- Water getting into the connector or circuitry
- Human error (mistakenly shorting a circuit, etc.)

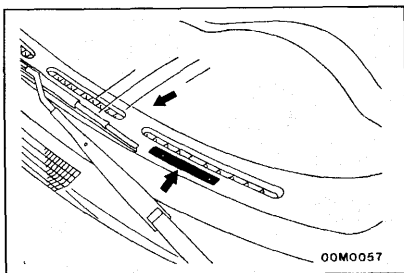

VEHICLE IDENTIFICATION

00100040387

VEHICLE IDENTIFICATION NUMBER LOCATION

The vehicle identification number (V.I.N.) is located on a plate attached to the left top side of the instrument panel.

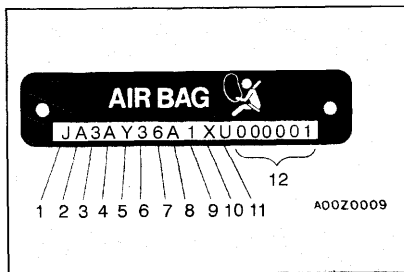

VEHICLE IDENTIFICATION CODE CHART PLATE

All vehicle identification numbers contain 17 digits. The vehicle number is a code which tells country, make, vehicle type, etc.

No.	Items	Contents
1	Country	J: JAPAN
2	Make	A: Mitsubishi
3	Vehicle type	3: Passenger car
4	Others	A: Driver and passenger air bags
5	Line	Y: MIRAGE
6	Price class	1: Economy
		2: Low
		3: Medium
		4: High
7	Body	1: 2-door sedan
		6: 4-door sedan
8	Engine	A: 1.5L
		C: 1.8L
9	Check digits*	1 2 3 4 5 6 7 8 9 X
10	Model year	X: 1999
11	Plant	U: Mizushima
12	Serial number	000001 to 999999

NOTE

* "Check digit" means a single number or letter X used to verify the accuracy of transcription of vehicle identification number.

VEHICLE IDENTIFICATION NUMBER LIST

2-DOOR MODELS FOR FEDERAL

V.I.N. (except sequence number)	Brand	Engine Displacement	Model Code
JA3AY11A_XU	Mitsubishi Mirage	1.5L [SOHC-MFI]	CJ2ADNSEL2M CJ2ADRSEL2M
JA3AY21A_XU			CJ2ADNMEL2M CJ2ADRMEEL2M
JA3AY31C_XU		1.8L [SOHC-MFI]	CJ5ADNDEL2M CJ5ADRDEL2M

2-DOOR MODELS FOR CALIFORNIA

V.I.N. (except sequence number)	Brand	Engine Displacement	Model Code
JA3AY11A_XU	Mitsubishi Mirage	1.5L [SOHC-MFI]	CJ2ADNSEL7M CJ2ADRSEL7M
JA3AY31C_XU		1.8L [SOHC-MFI]	CJ5ADNDEL7M CJ5ADRDEL7M

4-DOOR MODELS FOR FEDERAL

V.I.N. (except sequence number)	Brand	Engine Displacement	Model Code
JA3AY26A_XU	Mitsubishi Mirage	1.5L [SOHC-MFI]	CK2ASNDEL2M CK2ASRMEL2M
JA3AY36A_XU			CK2ASRDEL2M
JA3AY36C_XU		1.8L [SOHC-MFI]	CK5ASNDEL2M CK5ASRDEL2M
JA3AY46C_XU			CK5ASRJEL2M

4-DOOR MODELS FOR CALIFORNIA

V.I.N. (except sequence number)	Brand	Engine Displacement	Model Code
JA3AY26A_XU	Mitsubishi Mirage	1.5L [SOHC-MFI]	CK2ASNDEL7M CK2ASRMEL7M
JA3AY36C_XU		1.8L [SOHC-MFI]	CK5ASNDEL7M CK5ASRDEL7M

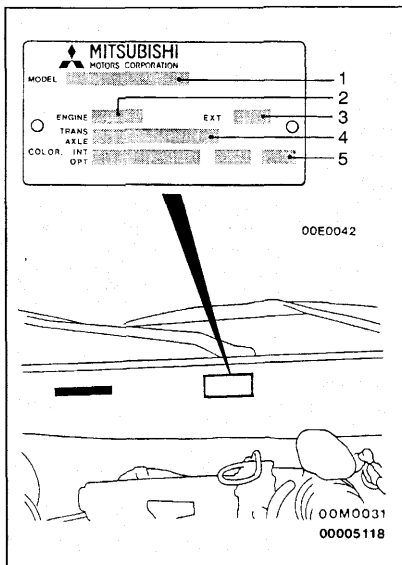

VEHICLE INFORMATION CODE PLATE

Vehicle information code plate is riveted onto the bulkhead in the engine compartment.

The plate shows model code, engine model, transaxle model, and body color code.

No.	Item	Contents	
1	MODEL	CJ2A	CJ2A: Vehicle model
		DNSEL2M	DNSEL2M: Model series
2	ENGINE	4G15	Engine model
3	EXT	B60B	Exterior code
4	TRANS	F5M41	Transaxle code
5	COLOR TRIM OPT	G84 41H 03V	G84: Body color code
			41H: Interior code
			03V: Equipment code

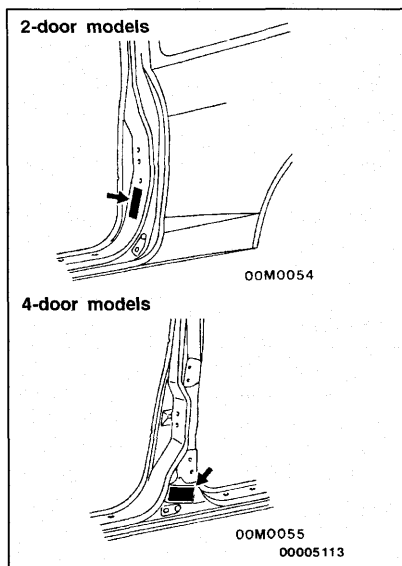

VEHICLE SAFETY CERTIFICATION LABEL

1. The vehicle safety certification label is attached to face of left door pillar.
2. This label indicates Gross Vehicle Weight Rating (G.V.W.R.), Gross Axle Weight Rating (G.A.W.R.) front, rear and Vehicle Identification Number (V.I.N.).

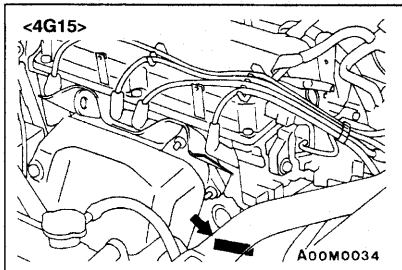

ENGINE MODEL STAMPING

- The engine model number is stamped at the front side on the top edge of the cylinder block as shown in the following.

Engine model	Engine displacement
4G15	1.5L
4G93	1.8L

- The engine serial number is stamped near the engine model number.

Engine serial number	AA0201 to YY9999
----------------------	------------------

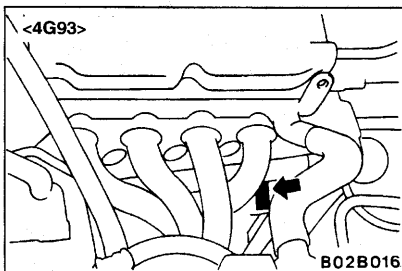

Theft protection label

For original parts

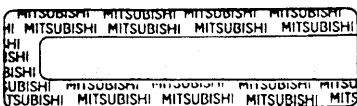

00K619

For replacement parts



00K621
00005114

THEFT PROTECTION

In order to protect against theft, a Vehicle Identification Number (VIN) is stamped in, or attached as a label to, the following major parts of the engine and transaxle, as well as main outer panels:

Engine cylinder block, Transaxle housing, Fender, Door, Quarter panel, Hood, Trunk lid, Bumpers

In addition, a theft-protection label is attached to replacement parts for the body outer panel main components, and the same data are stamped into replacement parts for the engine and the transaxle.

Cautions regarding panel repairs:

- When repainting original parts, do so after first masking the theft-protection label, and, after painting, be sure to peel off the masking tape.
- The theft-protection label for replacement parts is covered by masking tape, so such parts can be painted as is. The masking tape should be removed after painting is finished.
- The theft-protection label should not be removed from original parts or replacement parts.

LOCATIONS

Target area (A: for original equipment parts, B: for replacement parts)

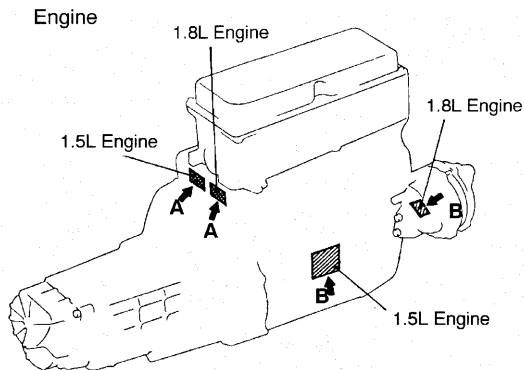

A00M0065

Manual transaxle

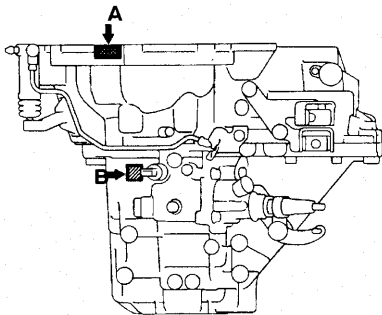

A00M0066

Automatic transaxle

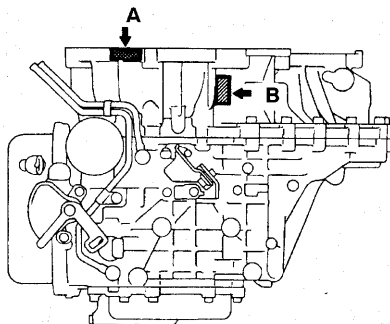

A00M0067

Fender

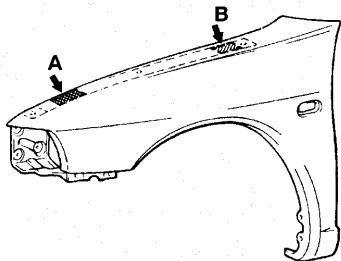

A00M0063

The illustration indicates left hand side, outer. Right hand side is symmetrically opposite.

Quarter panel

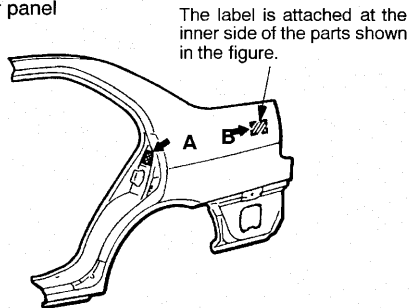

A00M0064

The illustration indicates left hand side, outer. Right hand side is symmetrically opposite.

Target area (A: for original equipment parts, B: for replacement parts)

Front door

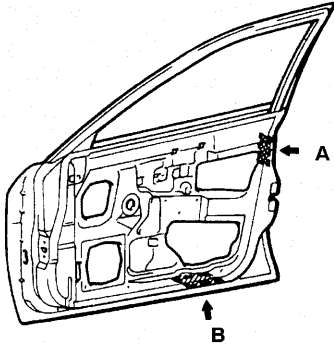

Rear door

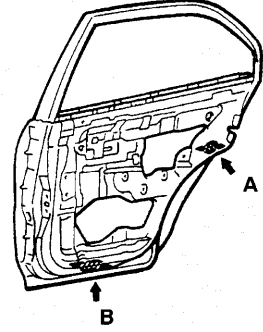

The illustration indicates right hand side, outer.
Left hand side is symmetrically opposite.

A00M0062

Hood

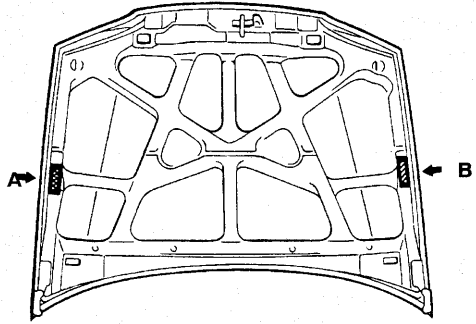

A00M0060

Trunk lid

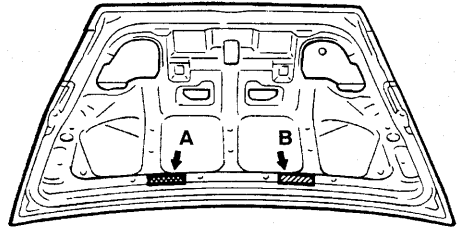

A00M0061

Front bumper

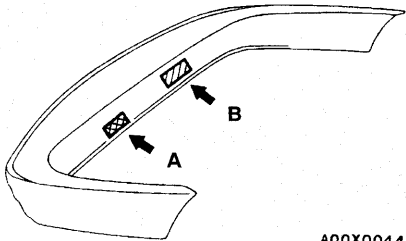

A00X0044

Rear bumper

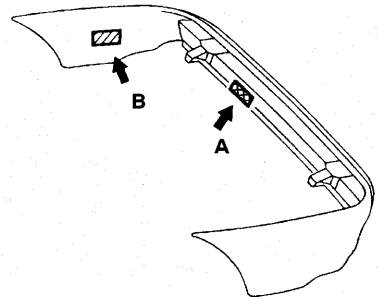

A00X0045

PRECAUTIONS BEFORE SERVICE

00100050182

SUPPLEMENTAL RESTRAINT SYSTEM (SRS)

1. Items to follow when servicing SRS
 - (1) Be sure to read GROUP 52B - Supplemental Restraint System (SRS).
For safe operations, please follow the directions and observe all warnings.
 - (2) Always use the designated special tools and test equipment.
 - (3) Wait at least 60 seconds after disconnecting the battery cable before doing any further work.
The SRS system is designed to retain enough voltage to deploy the air bag even after the battery has been disconnected. Serious injury may result from unintended air bag deployment if work is done on the SRS system immediately after the battery cable is disconnected.
 - (4) Never attempt to disassemble or repair the SRS components (SRS-ECU air bag module and clock spring). If faulty, replace it.
 - (5) Warning labels must be observe when servicing or handling SRS components. Warning labels are located in the following locations.
 - Sun visor
 - Glove box
 - SRS-ECU
 - Steering wheel
 - Air bag module
 - Clock spring
 - Steering gear box
 - (6) Store components removed from the SRS in a clean and dry place.
The air bag module should be stored on a flat surface and placed so that the pad surface is facing upward.
Do not place anything on top of it.
 - (7) Be sure to deploy the air bag before disposing of the air bag module or disposing of a vehicle equipped with an air bag. (Refer to GROUP 52B - Air Bag Module Disposal Procedures.)
 - (8) Whenever you finish servicing the SRS, check the SRS warning light operation to make sure that the system functions properly.
2. Observe the following when carrying out operations on places where SRS components are installed, including operations not directly related to the SRS air bag.
 - (1) When removing or installing parts do not allow any impact or shock to the SRS components.
 - (2) SRS components should not be subjected to heat over 93°C (200°F), so remove the SRS components before drying or baking the vehicle after painting.
After re-installing them, check the SRS warning light operation to make sure that the system functions properly.

SERVICING THE ELECTRICAL SYSTEM

1. Note the following before proceeding with work on the electrical system.
Note that the following must never be done:
Unauthorized modifications of any electrical device or wiring, because such modifications might lead to a vehicle malfunction, over-capacity or short-circuit that could result in a fire in the vehicle.

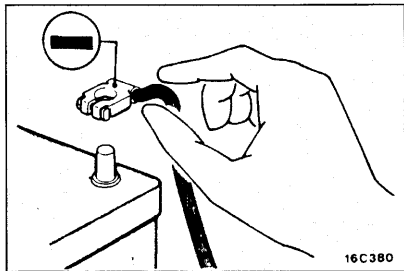

- When servicing the electrical system, disconnect the negative cable terminal from the battery.

Caution

- Before connecting or disconnecting the negative cable, be sure to turn off the ignition switch and the lighting switch.
(If this is not done, there is the possibility of semiconductor parts being damaged.)
- After completion of the work steps [when the battery's negative (-) terminal is connected], warm up the engine and allow it to idle for approximately ten minutes under the conditions described below, in order to stabilize the engine control conditions, and then check to be sure that idling is satisfactory.

Engine coolant temperature: 80–95°C (176–203°F)

Lights, electric fans, accessories: OFF

Transaxle: Neutral position

(A/T models: "N" or "P")

Steering wheel: neutral (center) position

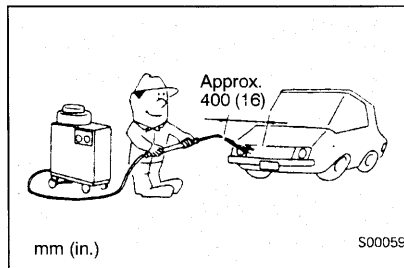

VEHICLE WASHING

If high-pressure car-washing equipment or steam car-washing equipment is used to wash the vehicle, be sure to maintain the spray nozzle at a distance of at least Approx. 400 mm (16 in.) from any plastic parts and all opening parts (doors, luggage compartment, etc.).

APPLYING RUST PREVENTIVES, UNDERCOAT, ETC.

Heated oxygen sensors have their functional efficiency decreased if they are smeared with oil or grease. When applying rust preventives, undercoat, etc., be sure to protect the heated oxygen sensor with a protective cover or the like.

SCAN TOOL

To operate the scan tool, refer to the "MUT-II OPERATING INSTRUCTIONS".

Caution

Turn off the ignition switch before disconnecting or connecting the scan tool.

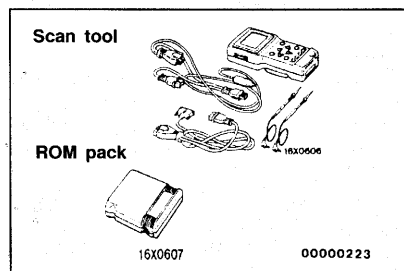

Sling type



Wheel lift type



Flat bed type

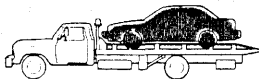

00F0027

Sling type



Wheel lift type



Flat bed type

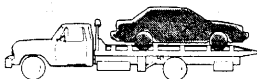

00F0026

TOWING AND HOISTING

00100080105

WRECKER TOWING RECOMMENDATION

FRONT TOWING PICKUP

Caution

This vehicle cannot be towed by a wrecker using sling-type equipment to prevent the bumper from deformation. If this vehicle is towed, use wheel lift or flat bed equipment.

The vehicle may be towed on its rear wheels for extended distances provided the parking brake is released. It is recommended that vehicles be towed using the front pickup whenever possible.

REAR TOWING PICKUP

Caution

1. This vehicle cannot be towed by a wrecker using sling-type equipment to prevent the lower arm from deformation. If this vehicle is towed, use wheel lift or flat bed equipment.
2. Do not use steering column lock to secure front wheel position for towing.
3. Make sure the transaxle is in Neutral if vehicle will be with drive wheels on the ground.

Automatic transaxle vehicle may be towed on the front wheels at speeds not to exceed 50 km/h (30 mph) for distances not to exceed 30 km (18 miles).

Caution

If these limits cannot be met, the front wheels must be placed on a tow dolly.

TOWING WHEN KEYS ARE NOT AVAILABLE

When a locked vehicle must be towed and keys are not available, the vehicle may be lifted and towed from the front, provided the parking brake is released. If not released, the rear wheels should be placed on a tow dolly.

SAFETY PRECAUTIONS

The following precautions should be taken when towing the vehicle.

1. DO NOT LIFT OR TOW THE VEHICLE BY ATTACHING TO OR WRAPPING AROUND THE BUMPER.
2. Any loose or protruding parts of damaged vehicle such as hoods, doors, fenders, trim, etc., should be secured or removed prior to moving the vehicle.
3. Operator should refrain from going under a vehicle while it is lifted by the towing equipment, unless the vehicle is adequately supported by safety stands.
4. Never allow passengers to ride in a towed vehicle.
5. State and local rules and regulations must be followed when towing a vehicle.

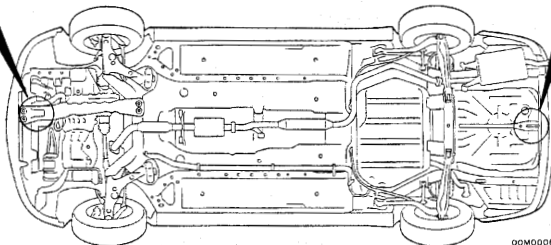
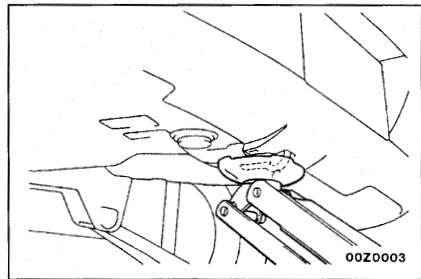
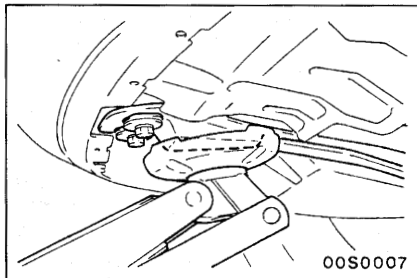
**LIFTING, JACKING SUPPORT LOCATION
FLOOR JACK**

00005001

Caution

Never support any point other than the specified one, or it will be deformed.

RIGID RACK

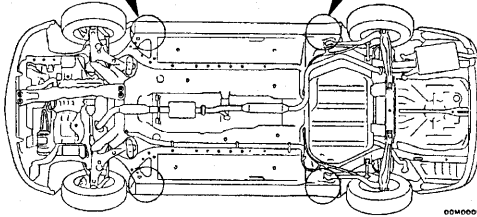
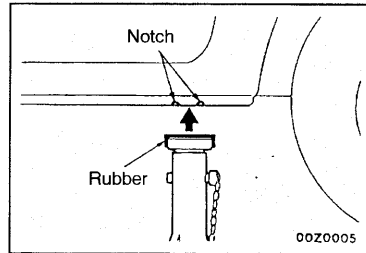
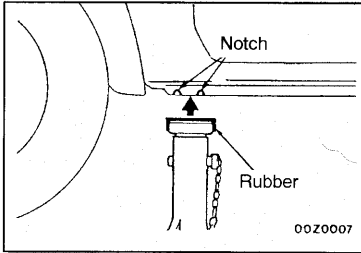

00005002

Caution

For lifting, put rubber or similar between the side sill and rigid rack, or the side sill area will be damaged.

POST TYPE

Special care should be taken when raising the vehicle on a frame contact type hoist. The hoist must be equipped with the proper adapters in order to support the vehicle at the proper locations.

Caution

When service procedures require removing rear suspension, fuel tank and spare tire, place additional weight on rear end of vehicle or anchor vehicle to hoist to prevent tipping of center of gravity changes.

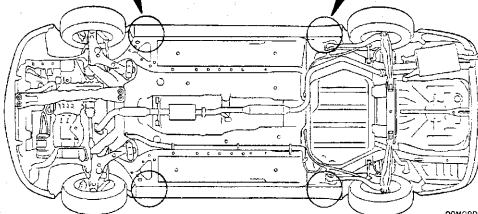
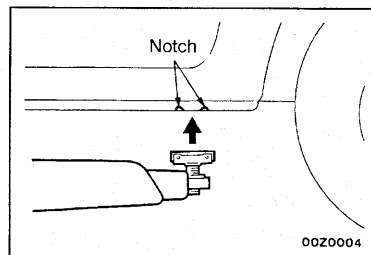
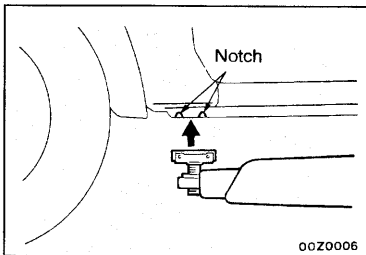

00005003

GENERAL DATA AND SPECIFICATIONS

00100090351

2-DOOR MODELS

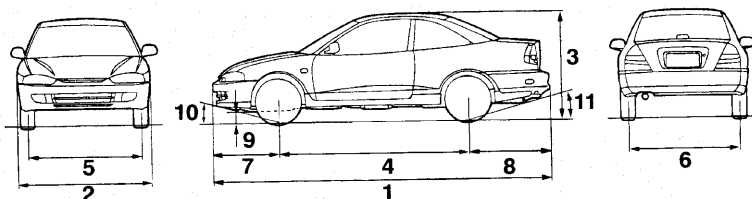

00M0049

GENERAL SPECIFICATIONS

Items		CJ2A DNSEL2M DNSEL7M	CJ2A DRSEL2M DRSEL7M	CJ2A DNMEL2M	CJ2A DRMEL2M	CJ5A DNDEL2M DNDEL7M	CJ5A DRDEL2M DRDEL7M	
Vehicle dimensions	Overall length mm (in.)	1 4,270 (168.1)	4,270 (168.1)	4,270 (168.1)	4,270 (168.1)	4,270 (168.1)	4,270 (168.1)	
	Overall width mm (in.)	2 1,690 (66.5)	1,690 (66.5)	1,690 (66.5)	1,690 (66.5)	1,690 (66.5)	1,690 (66.5)	
	Overall height (Unladen) mm (in.)	3 1,360 (53.5)	1,360 (53.5)	1,360 (53.5)	1,360 (53.5)	1,360 (53.5)	1,360 (53.5)	
	Wheel base mm (in.)	4 2,415 (95.1)	2,415 (95.1)	2,415 (95.1)	2,415 (95.1)	2,415 (95.1)	2,415 (95.1)	
	Tread-front mm (in.)	5 1,450 (57.1)	1,450 (57.1)	1,450 (57.1)	1,450 (57.1)	1,450 (57.1)	1,450 (57.1)	
	Tread-rear mm (in.)	6 1,460 (57.4)	1,460 (57.4)	1,460 (57.4)	1,460 (57.4)	1,460 (57.4)	1,460 (57.4)	
	Overhang-front mm (in.)	7 845 (33.3)	845 (33.3)	845 (33.3)	845 (33.3)	845 (33.3)	845 (33.3)	
	Overhang-rear mm (in.)	8 1,010 (39.8)	1,010 (39.8)	1,010 (39.8)	1,010 (39.8)	1,010 (39.8)	1,010 (39.8)	
	Minimum running ground clearance mm (in.)	9 150 (5.9)	150 (5.9)	150 (5.9)	150 (5.9)	150 (5.9)	150 (5.9)	
	Angle of approach degrees	10 15.8	15.8	15.8	15.8	15.8	15.8	
Angle of departure degrees	11 17.8	17.8	17.8	17.8	17.8	17.8		
Vehicle weight kg (lbs.)	Curb weight	965 (2,127)	985 (2,172)	970 (2,138)	990 (2,183)	1,025 (2,260)	1,045 (2,304)	
	Gross vehicle weight rating	1,495 (3,296)	1,495 (3,296)	1,495 (3,296)	1,495 (3,296)	1,495 (3,296)	1,495 (3,296)	
	Gross axle weight rating-front	830 (1,830)	830 (1,830)	830 (1,830)	830 (1,830)	830 (1,830)	830 (1,830)	
	Gross axle weight rating-rear	735 (1,621)	735 (1,621)	735 (1,621)	735 (1,621)	735 (1,621)	735 (1,621)	
Seating capacity		5						
Engine	Model No.	4G15				4G93		
	Piston displacement	1.5L				1.8L		
Trans-axle	Model No. Type	F5M41	F4A41	F5M41	F4A41	F5M42	F4A42	
		5-speed manual	4-speed automatic	5-speed manual	4-speed automatic	5-speed automatic	4-speed automatic	
Fuel system	Fuel supply system	Electronically-controlled multiport fuel injection						

4-DOOR MODELS

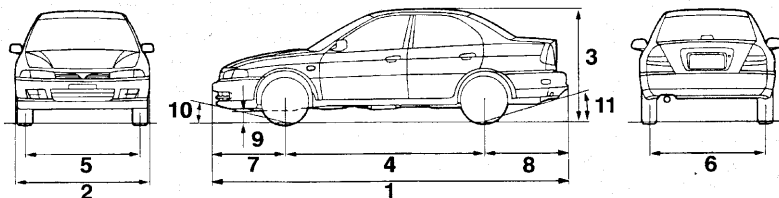

00M0050

GENERAL SPECIFICATIONS

Items		CK2A SNMEL2M SNMEL7M	CK2A SRMEL2M SRMEL7M	CK2A SRDEL2M	CK5A SNDEL2M SNDEL7M	CK5A SRDEL2M SRDEL7M	CK5A SRJEL2M
Vehicle dimensions	Overall length mm (in.)	1 4,410 (173.6)	4,410 (173.6)	4,410 (173.6)	4,410 (173.6)	4,410 (173.6)	4,410 (173.6)
	Overall width mm (in.)	2 1,690 (66.5)	1,690 (66.5)	1,690 (66.5)	1,690 (66.5)	1,690 (66.5)	1,690 (66.5)
	Overall height (Unladen) mm (in.)	3 1,390 (54.7)	1,390 (54.7)	1,390 (54.7)	1,390 (54.7)	1,390 (54.7)	1,390 (54.7)
	Wheel base mm (in.)	4 2,500 (98.4)	2,500 (98.4)	2,500 (98.4)	2,500 (98.4)	2,500 (98.4)	2,500 (98.4)
	Tread-front mm (in.)	5 1,450 (57.1)	1,450 (57.1)	1,450 (57.1)	1,450 (57.1)	1,450 (57.1)	1,450 (57.1)
	Tread-rear mm (in.)	6 1,460 (57.4)	1,460 (57.4)	1,460 (57.4)	1,460 (57.4)	1,460 (57.4)	1,460 (57.4)
	Overhang-front mm (in.)	7 900 (35.4)	900 (35.4)	900 (35.4)	900 (35.4)	900 (35.4)	900 (35.4)
	Overhang-rear mm (in.)	8 1,010 (39.8)	1,010 (39.8)	1,010 (39.8)	1,010 (39.8)	1,010 (39.8)	1,010 (39.8)
	Minimum running ground clearance mm (in.)	9 150 (5.9)	150 (5.9)	150 (5.9)	150 (5.9)	150 (5.9)	150 (5.9)
	Angle of approach degrees	10 15.8	15.8	15.8	15.8	15.8	15.8
Angle of departure degrees	11 17.8	17.8	17.8	17.8	17.8	17.8	
Vehicle weight kg (lbs.)	Curb weight	1,010 (2,227)	1,030 (2,271)	1,030 (2,271)	1,065 (2,348)	1,085 (2,392)	1,090 (2,403)
	Gross vehicle weight rating	1,550 (3,418)	1,550 (3,418)	1,550 (3,418)	1,550 (3,418)	1,550 (3,418)	1,550 (3,418)
	Gross axle weight rating-front	830 (1,830)	830 (1,830)	830 (1,830)	830 (1,830)	830 (1,830)	830 (1,830)
	Gross axle weight rating-rear	790 (1,742)	790 (1,742)	790 (1,742)	790 (1,742)	790 (1,742)	790 (1,742)
Seating capacity		5					
Engine	Model No.	4G15			4G93		
	Piston displacement	1.5L			1.8L		
Trans-axle	Model No.	F5M41	F4A41	F5M42	F4A42		
	Type	5-speed manual	4-speed automatic	5-speed automatic	4-speed automatic		
Fuel system	Fuel supply system	Electronically-controlled multipoint fuel injection					

TIGHTENING TORQUE

00100110026

Each torque value in the table is a standard value for tightening under the following conditions.

- (1) Bolts, nuts and washers are all made of steel and plated with zinc.
- (2) The threads and bearing surface of bolts and nuts are all in dry condition.

The values in the table are not applicable:

- (1) If toothed washers are inserted.
- (2) If plastic parts are fastened.
- (3) If bolts are tightened to plastic or die-cast inserted nuts.
- (4) If self-tapping screws or self-locking nuts are used.

Standard bolt and nut tightening torque

Thread size		Torque Nm (ft.lbs.)		
Bolt nominal diameter (mm)	Pitch (mm)	Head mark "4"	Head mark "7"	Head mark "8"
M5	0.8	2.5 (1.8)	5 (3.6)	6 (4.3)
M6	1.0	5 (3.6)	9 (6.5)	10 (7.2)
M8	1.25	12(8.7)	22 (16)	25 (18)
M10	1.25	24 (17)	44 (33)	52 (38)
M12	1.25	41 (30)	81 (60)	96 (71)
M14	1.5	72 (53)	137 (101)	157 (116)
M16	1.5	111 (82)	206 (152)	235 (174)
M18	1.5	167 (123)	304 (224)	343 (253)
M20	1.5	226 (166)	412 (304)	481 (354)
M22	1.5	304 (224)	559 (412)	647 (477)
M24	1.5	392 (289)	735 (542)	853 (629)

Flange bolt and nut tightening torque

Thread size		Torque Nm (ft.lbs.)		
Bolt nominal diameter (mm)	Pitch (mm)	Head mark "4"	Head mark "7"	Head mark "8"
M6	1.0	5 (3.6)	10 (7.2)	12 (8.7)
M8	1.25	13 (9.4)	24 (17)	28 (20)
M10	1.25	26 (19)	49 (36)	57 (42)
M10	1.5	24 (17)	44 (33)	54 (40)
M12	1.25	46 (34)	93 (69)	103 (76)
M12	1.75	42 (31)	81 (60)	96 (71)

LUBRICATION AND MAINTENANCE

00100120234

Maintenance and lubrication service recommendations have been compiled to provide maximum protection for the vehicle owner's investment against all reasonable types of driving conditions. Since these conditions vary with the individual vehicle owner's driving habits, the area in which the vehicle is operated and the type of driving to which the vehicle is subjected, it is necessary to prescribe lubrication and maintenance service on a time frequency as well as mileage interval basis.

Oils, lubricants and greases are classified and graded according to standards recommended by the Society of Automotive Engineers (SAE), the American Petroleum Institute (API) and the National Lubricating Grease Institute (NLGI).

MAINTENANCE SCHEDULES

Information for service maintenance is provided under "SCHEDULED MAINTENANCE TABLE".

Three schedules are provided; one for "Required Maintenance", one for "General Maintenance" and one for "Severe Usage Service".

Item numbers in the "SCHEDULED MAINTENANCE TABLE" correspond to the item numbers in the "MAINTENANCE SERVICE" section.

SEVERE SERVICE

Vehicles operating under severe service conditions will require more frequent service.

Component service information is included in appropriate units for vehicles operating under one or more of the following conditions:

1. Police, taxi, or commercial type operation
2. Operation of Vehicle
 - (1) Short-trip operation at freezing temperature (engine not thoroughly warmed up)
 - (2) More than 50% operation in heavy city traffic during hot weather above 32°C (90°F)
 - (3) Extensive idling
 - (4) Driving in sandy areas
 - (5) Driving in salty areas
 - (6) Driving in dusty conditions

ENGINE OIL

Either of the following engine oils should be used:

- (1) Engine oil displaying EOLCS certification mark
- (2) Engine oil conforming to the API classification SJ EC or SJ/CD EC.

For further details, refer to "LUBRICANTS SELECTION" section.

Caution

Test results submitted to EPA have shown that laboratory animals develop skin cancer after prolonged contact with used engine oil. Accordingly, the potential exists for humans to develop a number of skin disorders, including cancer, from such exposure to used engine oil.

Care should be taken, therefore, when changing engine oil, to minimize the amount and length of exposure time to used engine oil on your skin. Protective clothing and gloves, that cannot be penetrated by oil, should be worn. The skin should be thoroughly washed with soap and water, or use waterless hand cleaner, to remove any used engine oil. Do not use gasoline, thinners, or solvents.

LUBRICANTS - GREASES

Semi-solid lubricants bear the NLGI designation and are further classified as grades 0, 1, 2, 3 etc. Whenever "Chassis Lubricant" is specified, Multi-Purpose Grease, NLGI grade 2, should be used.

FUEL USAGE STATEMENT

Your car must use unleaded gasoline only. This car has a fuel filler tube especially designed to accept only the smaller-diameter unleaded gasoline dispensing nozzle.

Caution

Using leaded gasoline in your car will damage the catalytic converter and the oxygen sensor, and affect the warranty coverage validity.

Your car is designed to operate on premium unleaded gasoline having a minimum octane rating of 87, or 91 RON (Research Octane Number).

Gasolines Containing Alcohol

Some gasolines sold at service stations contain alcohol, although they may not be so identified. Use of fuels containing alcohol is not recommended unless the nature of the blend can be determined as being satisfactory.

Gasohol - A mixture of 10% ethanol (grain alcohol) and 90% unleaded gasoline may be used in your car.

If driveability problems are experienced as a result of using gasohol, it is recommended that the car be operated on gasoline.

Methanol - **Do not use gasolines containing methanol** (wood alcohol). Use of this type of alcohol can result in vehicle performance deterioration and damage critical parts in the fuel system components. Fuel system damage and performance problems, resulting from the use of gasolines containing methanol, may not be covered by the new car warranty.

Gasolines containing MTBE (Methyl Tertiary Butyl Ether)

Unleaded gasoline containing 15% or less MTBE may be used in your car. Fuel containing MTBE over 15% vol. may cause reduced engine performance and produce vapor lock or hard starting.

MATERIALS ADDED TO FUEL

Indiscriminate use of fuel system cleaning agents should be avoided. Many of these materials intended for gum and varnish removal may contain highly active solvents or similar ingredients that can be harmful to gasket and diaphragm materials used in fuel system component parts.

RECOMMENDED LUBRICANT AND LUBRICANT CAPACITY TABLE

00100130305

RECOMMENDED LUBRICANTS

Items	Recommended lubricants
Engine	Engine oil displaying EOLCS certification mark or conforming to the API classification SJ EC or SJ/CD EC (For further details, refer to "LUBRICANTS SELECTION" section)
Manual transaxle	API classification GL-4, SAE 75W-90 OR 75W-85
Automatic transaxle	DIAMOND ATF SP II, DIAMOND ATF SP II M or equivalent
Power steering	Automatic transmission fluid "DEXRON II"
Brake and clutch	Conforming to DOT3 or DOT4
Engine coolant	DIA-QUEEN LONG-LIFE COOLANT (Part No.0103044) or high quality ethylene-glycol antifreeze coolant

LUBRICANT CAPACITY TABLE

Description		Metric measure	U.S. measure	
Engine oil	Crankcase (excluding oil filter)	1.5L Engine	3.0 dm ³	3.2 qts.
		1.8L Engine	3.5 dm ³	3.7 qts.
	Oil filter		0.3 dm ³	.32 qts.
Cooling system (including heater and coolant reserve system)	1.5L Engine	5 dm ³	5.3 qts.	
	1.8L Engine	6 dm ³	6.3 qts.	
Manual transaxle	F5M41	2.1 dm ³	2.2 qts.	
	F5M42	2.2 dm ³	2.3 qts.	
Automatic transaxle		7.8 dm ³	8.2 qts.	
Power steering		0.9 dm ³	.95 qt.	
Fuel tank		50 dm ³	13.2 gals.	

EOLCS certification mark



M03A015

LUBRICANTS SELECTION

ENGINE OIL

Caution

Never use nondetergent or straight mineral oil.

Oil Identification Symbol

Use only engine oils displaying the EOLCS certification mark on the container.

If these oils are not available, an API classification SJ EC or SJ/CD EC can be used.

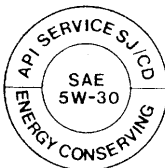

M03A041A

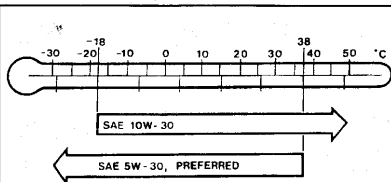

M03B007

Oil Viscosity

The SAE grade number indicates the viscosity of the oil. A proper SAE grade number should be selected according to ambient temperature.

SELECTION OF COOLANT

COOLANT

Relation between Antifreeze Concentration and Specific Gravity

Engine coolant temperature °C (°F) and specific gravity					Freezing temperature	Safe operating temperature	Engine coolant concentration (Specific volume)
10 (50)	20 (68)	30 (86)	40 (104)	50 (122)	°C (°F)	°C (°F)	%
1.054	1.050	1.046	1.042	1.036	-16 (3.2)	-11 (12.2)	30
1.063	1.058	1.054	1.049	1.044	-20 (-4)	-15 (5)	35
1.071	1.067	1.062	1.057	1.052	-25 (-13)	-20 (-4)	40
1.079	1.074	1.069	1.064	1.058	-30 (-13)	-25 (-13)	45
1.087	1.082	1.076	1.070	1.064	-36 (-32.8)	-31 (-23.8)	50
1.095	1.090	1.084	1.077	1.070	-42 (-44)	-37 (-35)	55
1.103	1.098	1.092	1.084	1.076	-50 (-58)	-45 (-49)	60

Example

The safe operating temperature is -15°C (5°F) when the measured specific gravity is 1.058 at the coolant temperature of 20°C (68°F).

Caution

1. If the concentration of the coolant is below 30%, the anti-corrosion property will be adversely affected. In addition, if the concentration is above 60%, both the anti-freeze and engine cooling properties will decrease, affecting the engine adversely. For these reasons, be sure to maintain the concentration level within the specified range.
2. Do not use a mixture of different brands of anti-freeze.

SCHEDULED MAINTENANCE TABLE

00100140230

SCHEDULED MAINTENANCE SERVICES FOR EMISSION CONTROL AND PROPER VEHICLE PERFORMANCE

Inspection and services should be performed any time a malfunction is observed or suspected. Retain receipts for all vehicle emission services to protect your emission warranty.

No.	Emission control system maintenance	Service to be performed	Kilometers in thousands	24	48	72	96	120	144	168
			Mileage in thousands	15	30	45	60	75	90	105
1	Fuel system (Tank, pipe line and connection, and fuel tank filler tube cap)	Check for leaks Every 5 years or					×			
2	Fuel hoses	Check condition Every 2 years or		×		×			×	
3	Air cleaner element	Replace at		×		×			×	
4	Evaporative emission control system (except evaporative emission canister)	Check for leaks and clogging Every 5 years or					×			
5	Spark plugs	Replace at		×		×			×	
6	Ignition cables	Replace Every 5 years or					×			
7	Distributor cap and rotor	Check Every 5 years or					×			

GENERAL MAINTENANCE SERVICE FOR PROPER VEHICLE PERFORMANCE

No.	General maintenance	Service to be performed	Kilometers in thousands	24	48	72	96	120	144	168
			Mileage in thousands	15	30	45	60	75	90	105
8	Timing belts	Replace at					×*1			160,000Km*2 (100,000 miles)
9	Drive belt (for generator, water pump, power steering pump)	Check condition at		×		×			×	
10	Engine oil	Change Every year or	Every 12,000 km (7,500 miles)							
11	Engine oil filter	Replace Every Year or*3	×	×	×	×	×	×	×	×
12	Manual transaxle oil	Check oil level at		×		×		×		
13	Automatic transaxle fluid	Check fluid level Every year or	×	×	×	×	×	×	×	×
14	Engine coolant	Change Every 2 years or		×		×		×		
15	Disc brake pads	Inspect for wear Every year or	×	×	×	×	×	×	×	×
16	Rear drum brake linings and rear wheel cylinders	Inspect for wear and leaks Every 2 years or		×		×		×		
17	Brake hoses	Check for deterioration or leaks Every year or	×	×	×	×	×	×	×	×
18	Ball joint and steering linkage seals	Inspect for grease leaks and damage Every 2 years or		×		×		×		
19	Drive shaft boots	Inspect for grease leaks and damage Every year or	×	×	×	×	×	×	×	×
20	SRS *4 air bag system	Inspect system	At 10 years							
21	Exhaust system (connection portion of muffler, pipings and converter heat shields)	Check and service as required Every 2 years or		×		×		×		×

NOTE

*1: For California, Massachusetts and Connecticut, this maintenance is recommended but not required.

*2: Not required if belt was previously changed.

*3: If the mileage is less than 12,000 km (7,500 miles) each year, the oil filter should be replaced at oil change.

*4: Supplemental Restraint System

SCHEDULED MAINTENANCE UNDER SEVERE USAGE CONDITIONS

The maintenance items should be performed according to the following table:

No.	Maintenance item	Service to be performed	Kilometers in thousands								Severe usage conditions
			24	48	72	96	120	144	168		
			Mileage in Thousands								
			15	30	45	60	75	90	105		
3	Air cleaner element	Replace	x	x	x	x	x	x	x	A and E	
5	Spark plugs	Replace	x	x	x	x	x	x	x	B and D	
10	Engine oil	Change Every 3 months or	Every 4,800 km (3,000 miles)								A,B,C,D and G
11	Engine oil filter	Replace Every 6 months or	Every 9,600 km (6,000 miles)								A,B,C,D and G
12	Manual transaxle oil	Change oil		x		x		x		B,G and H	
13	Automatic transaxle fluid	Change fluid at		x		x		x		B, G and H	
	Automatic transaxle external fluid filter	Change fluid filter at		x		x		x		B, G and H	
15	Disc brake pads	Inspect for wear and leaks Every 6 months or	Every 9,600 km (6,000 miles)								A and F
16	Rear drum brake linings and rear wheel cylinders	Inspect for wear and leaks Every year or	x	x	x	x	x	x	x	A and F	

Severe usage conditions

- A: Driving in dusty conditions
- B: Trailer towing or police, taxi, or commercial type operation
- C: Extensive idling, driving in stop and go traffic
- D: Short-trip operation at freezing temperatures (engine not thoroughly warmed up)

- E: Driving in sandy areas
- F: Driving in salty areas
- G: More than 50% operation in heavy city traffic or at sustained high speeds driving hot weather above 32°C (90°F)
- H: Driving off-road

MAINTENANCE SERVICE

00100780029

1. FUEL SYSTEM (Tank, Pipe Lines, Connections and Fuel Tank Filler Tube Cap) (Check for leaks)/2. FUEL HOSES (Check condition)

00100160106

1. Check for damage or leakage in the fuel lines and connections and looseness of the fuel tank filler tube cap.
2. Inspect the surface of fuel hoses for heat and mechanical damage. Hard and brittle rubber, cracking, checking, tears, cuts, abrasions and excessive swelling indicate deterioration of the rubber.
3. If the fabric casing of the rubber hose is exposed by cracks and abrasions in the fuel system, the hoses should be replaced.

3. AIR CLEANER ELEMENT (Replace)

00100180157

The air cleaner element will become dirty and loaded with dust during use, and the filtering effect will be substantially reduced.

Replace it with a new one.

- (1) Unclamp the air cleaner cover.
- (2) Take out the air cleaner element, install a new one.
- (3) Be sure when clamping the air cleaner cover in place that the cover is completely closed.

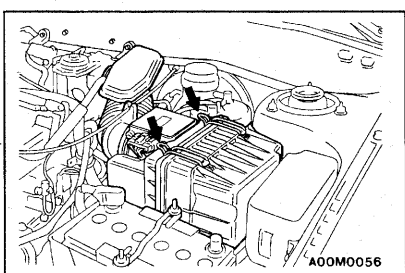

4. EVAPORATIVE EMISSION CONTROL SYSTEM (Check for leaks and clogging) - except evaporative emission canister

00100190129

1. If the fuel-vapor vent line is clogged or damaged, a fuel vapor mixture escapes into the atmosphere causing excessive emissions. Disconnect the line at both ends, and blow it clean with compressed air. Remove the fuel tank filler tube cap from the fuel tank filler tube and check to see if there is evidence that the packing makes improper contact to the fuel tank filler tube.
2. The fuel tank pressure control valve installed on the vapor line should be checked for correct operation.

5. SPARK PLUGS (Replace)

00100200204

1. Spark plugs must spark properly to assure proper engine performance and reduce exhaust emission level. Therefore, they should be replaced periodically with new ones.

Spark plug type

Maker	1.5L Engine	1.8L Engine
NGK	BPR5ES-11	BKR5E-11
DENSO	W16EPR11	K16PR-U11
CHAMPION	RN11YC4	RC10YC4

2. The new plugs should be checked for the proper gap.

Spark plug gap: 1.0-1.1 mm (.039-.043 in.)

3. Install the spark plug and tighten to 25 Nm (18 ft.lbs.)

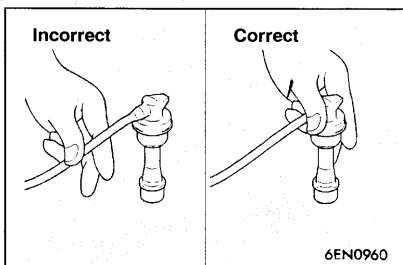

6. IGNITION CABLES (Replace)

00100210115

The ignition cables should be replaced periodically with new ones. After replacing, make sure that the ignition cables are routed properly and fully seated.

NOTE

When disconnecting an ignition cable, be sure to hold the cable boot. If the cable is disconnected by pulling on the cable alone, an open circuit might result.

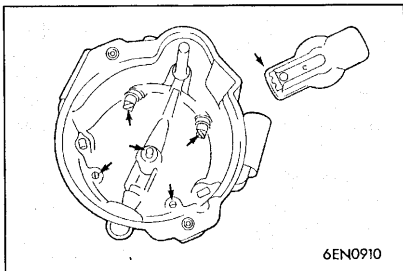

7. DISTRIBUTOR CAP AND ROTOR (Check)

00100220101

Check the distributor cap and rotor to maintain driveability and reduce exhaust emissions.

DISTRIBUTOR CAP AND ROTOR INSPECTION

Inspect in accordance with the following procedure. Repair or replace as necessary.

- Check the cap for cracks.
- Check the cap and rotor electrodes for damage.
- Wipe clean the cap and rotor.
- Clean the corrosion off the terminals inside the distributor cap.

8. TIMING BELT (Replace)

00100230166

Replace the belt with a new one periodically to assure proper engine performance.

For disassembly and assembly procedures, refer to GROUP 11A - Timing Belt or GROUP 11C - Timing Belt.

9. DRIVE BELT

For Generator, Water Pump, Power Steering Pump (Check condition)

Check the tension of the drive belt. Inspect the drive belt for evidence of cuts and cracks and replace it if defective.

WATER PUMP AND GENERATOR

1. Check the drive belt tension with one of the following methods.

Standard value:

Items	1.5L engine	1.8L engine
Vibration frequency Hz	150 - 184	151 - 195
Tension N (lbs.)	392 - 588 (88 - 132)	294 - 490 (66 - 110)
Deflection (Reference value) mm (in.)	8.7 - 11.4 (.34 - .45)	8.0 - 10.5 (.31 - .41)

When using the scan tool (MUT-II)

1. Connect the special tool (belt tension meter set) to the scan tool (MUT-II).
2. Connect the scan tool (MUT-II) to the diagnosis connector.
3. Set the ignition switch to the ON position, and select "Belt Tension Measurement" on the menu screen.
4. Place the microphone approx. 10 to 20 mm (.39 to .79 in.) from the rear center (arrow section) of the pulleys shown in the illustration.
5. With a finger, lightly press the center (arrow section) of the pulleys shown in the illustration, and check that the vibration frequency of the belt is at the standard value.

Caution

1. Measure the belt surface temperature when it is close to the room temperature.
2. Make sure that water and oil, etc., do not come in contact with the microphone.
3. When measuring, if the microphone is subject to strong winds, or if there is noise in the near area, a value differing from the actual value may be indicated.
4. If the measurement is carried out when the microphone is contacting the belt, a value differing from the actual value may be indicated.
5. Do not measure while the engine is running.

When using belt tension gauge

Use a belt tension gauge to check that the belt tension is at the standard value.

When checking the deflection amount

Apply a pressing force of 98 N (22 lbs.) at the center (arrow section) of the pulleys shown in the illustration, and check that the amount of belt deflection is at the standard value.

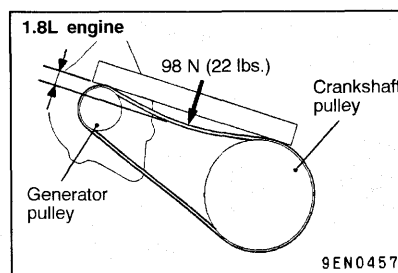
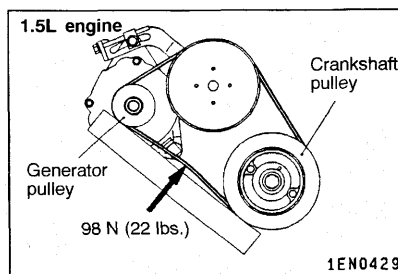
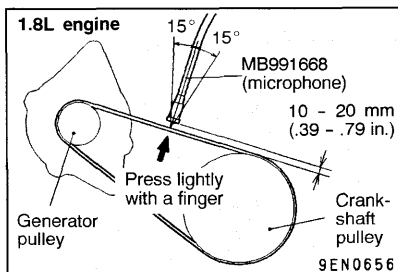
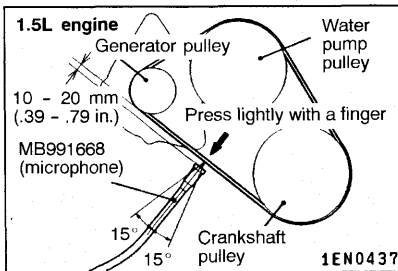

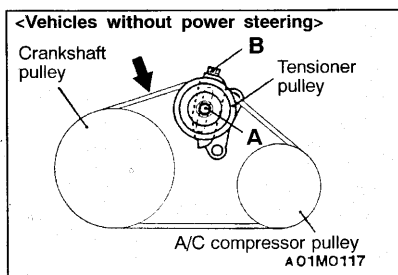
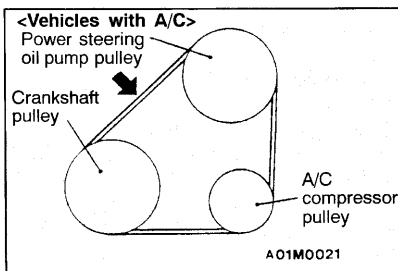
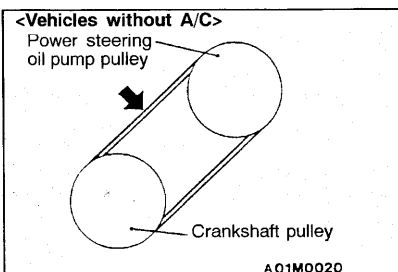
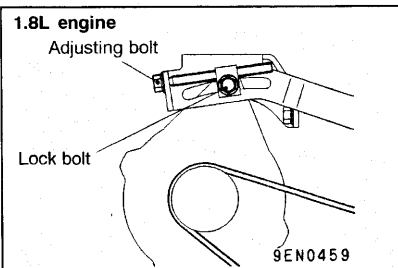
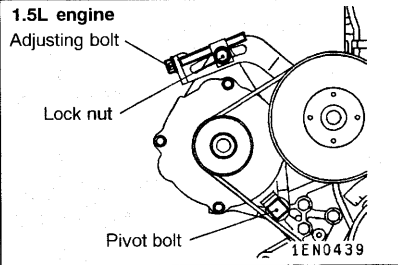

2. When deviated from standard value, adjust with the following procedure.

- (1) Loosen the nut of the generator pivot bolt.
- (2) Loosen the lock bolt.
- (3) Turn the adjusting bolt to adjust the belt tension's vibration frequency, belt tension or deflection to the standard value.
- (4) Tighten the nut of the generator pivot bolt.

Tightening torque: 44 Nm (33 ft.lbs.)

- (5) Tighten the lock bolt.

Tightening torque: 23 Nm (17 ft.lbs.)

- (6) Tighten the adjusting bolt.

Tightening torque: 9.8 Nm (7.2 ft.lbs.)

POWER STEERING OIL PUMP AND AIR CONDITIONING COMPRESSOR DRIVE BELT TENSION CHECK AND ADJUSTMENT

<Vehicles with 1.5L Engine>

1. Check the drive belt tension with one of the following methods.

Standard value:

Items	When checked	When a used belt is intalled	When a new belt is installed
Vibration frequency Hz	137 - 168	145 - 160	174 - 199
Tension N (lbs.)	392 - 588 (88 - 132)	441 - 539 (99 - 121)	637 - 833 (143 - 187)
Deflection (Reference value) mm (in.)	9.6 - 12.4 (.38 - .49)	10.2 - 11.6 (.40 - .46)	7.2 - 9.0 (.28 - .35)

When using the scan tool (MUT-II)

With a finger, press the center (arrow section) of the pulleys shown in the illustration, and check that the vibration frequency of the belt is at the standard value.

NOTE

To measure the vibration frequency with the scan tool (MUT-II), use the same procedure as the WATER PUMP AND GENERATOR drive belt.

When using belt tension gauge

Use a belt tension gauge to check that the belt tension is at the standard value at a point half-way between the two pulleys (indicated by an arrow in the illustration).

When checking the deflection amount

Apply a pressing force of 98N (22 lbs.) at the center (arrow section) of the pulleys shown in the illustration, and check that the amount of belt deflection is at the standard value.

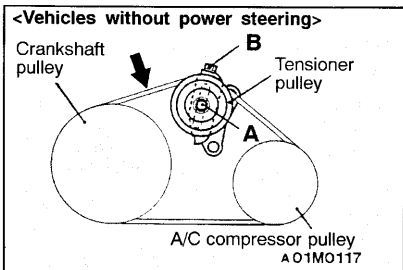
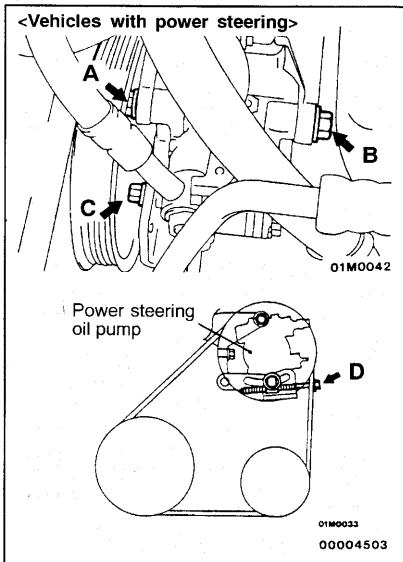

- If the tension or deflection is outside the standard value, adjust by the following procedure.

<Vehicles with power steering>

- Loosen power steering oil pump fixing bolts A, B and C.
- Adjust the amount of belt deflection using adjusting bolt D.
- Tighten fixing bolts A, B and C.

Tightening torque:

Bolts A and B: 39 Nm (29 ft.lbs.)

Bolt C: 49 Nm (36 ft.lbs.)

- Check the belt deflection amount and tension, and readjust if necessary.

Caution

Check after turning the crankshaft once or more clockwise (right turn).

<Vehicles without power steering>

- Loosen tension pulley fixing nut A.
- Adjust the amount of belt deflection using adjusting bolt B.
- Tighten fixing nut A.

Tightening torque: 25 Nm (19 ft.lbs.)

- Check the belt deflection amount and tension, and readjust if necessary.

Caution

Check after turning the crankshaft once or more clockwise (right turn).

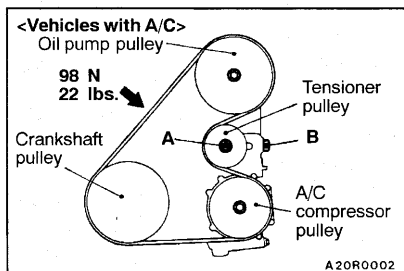
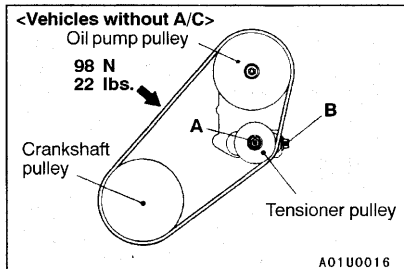
**<Vehicles with 1.8L Engine>**

1. Check the drive belt tension with one of the following methods.

Standard value:

Items	When checked	When a used belt is installed	When a new belt is installed
Vibration frequency Hz	114 - 139	121 - 133	145 - 166
Tension N (lbs.)	392 - 588 (88 - 132)	441 - 539 (99 - 121)	637 - 833 (143 - 187)
Deflection (Reference value) mm (in.)	10.0-12.0 (.39 - .47)	10.0-11.0 (.39 - .43)	7.2-9.0 (.28 - .35)

When using the scan tool (MUT-II)

With a finger, press the center (arrow section) of the pulleys shown in the illustration, and check that the vibration frequency of the belt is at the standard value.

NOTE

To measure the vibration frequency with the scan tool (MUT-II), use the same procedure as the WATER PUMP AND GENERATOR drive belt.

When using belt tension gauge

Use a belt tension gauge to check that the belt tension is at the standard value at a point half-way between the two pulleys (indicated by an arrow in the illustration).

When checking the deflection amount

Apply a pressing force of 98 N (22 lbs.) at the center (arrow section) of the pulleys shown in the illustration, and check that the amount of belt deflection is at the standard value.

2. If the tension or deflection is outside the standard value, adjust by the following procedure.
 - (1) Loosen tensioner pulley fixing nut A.
 - (2) Adjust the amount of belt deflection using adjusting bolt B.
 - (3) Tighten fixing nut A.

Tightening torque: 25 Nm (19 ft.lbs.)

- (4) Check the belt deflection amount and tension, and readjust if necessary.

Caution

Check after turning the crankshaft once or more clockwise (right turn).

10. ENGINE OIL (Change)

00100260264

Use the specified oil. (Refer to P.00-29.)

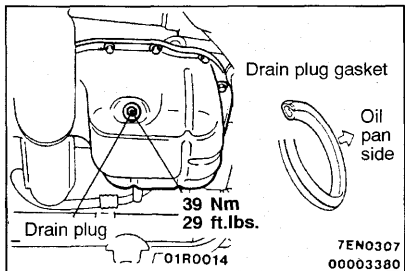
Caution**Never use nondetergent or straight mineral oil.**

1. Start the engine and allow it to warm up until the temperature of the coolant reaches 80°C (176°F) to 90°C (194°F).
2. Remove the engine oil filler cap.
3. Remove the drain plug to drain oil.

Caution**Use care as oil could be hot.**

4. Install a new drain plug gasket so that it faces in the direction shown in the illustration, and then tighten the drain plug to the specified torque.

NOTE

Install the drain plug gasket so it faces in the direction shown in the illustration.

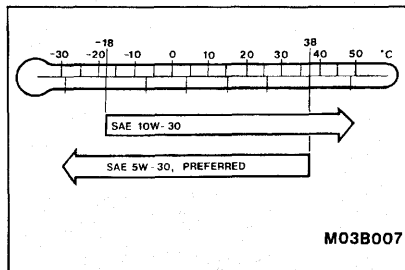

5. Refill with specified quantity of oil.

Specified Engine Oil (API classification): SJ or higher**Total quantity (Includes volume inside oil filter):**<1.5L Engine> 3.3 dm³ (3.5 qts.)<1.8L Engine> 3.8 dm³ (4.0 qts.)

6. Install the engine oil filler cap.
7. Check oil level.

11. ENGINE OIL FILTER (Change)

00100270205

The quality of replacement filters varies considerably. Only high quality filters should be used to assure most efficient service.

Genuine oil filters are capable of withstanding a pressure of 256 psi. These high quality filters are highly recommended. The following parts are available as follows:

Oil Filter Part No.**Mitsubishi Genuine Parts:**

MD135737, MD325714 or equivalent

ENGINE OIL FILTER SELECTION

This vehicle is equipped with a full-flow, throw-away oil filter. The same type of replacement filter is recommended as a replacement filter for this vehicle. It is possible, particularly in cold weather, that this vehicle may develop high oil pressure for a short duration. You should be sure that any replacement filter used on this vehicle is a high-quality filter and is capable of withstanding a pressure of 1,765 kPa (256 psi) (manufacturer's specifications) to avoid filter and engine damage. The following is a high-quality filter and is strongly recommended for use on this vehicle : Mitsubishi Engine Oil Filter Part No. MD135737 or MD325714.

Any replacement oil filter should be installed in accordance with the oil filter manufacturer's installation instructions.

1. Start the engine and allow it to warm up until the temperature of the coolant reaches 80°C (176°F) to 90°C (194°F).
2. Remove the engine oil filler cap.
3. Remove the drain plug to drain oil.

Caution

Use care as oil could be hot.

4. Use the following tools to remove the engine oil filter from the underside of the vehicle.
 - MB991396 or equivalent (When using the oil filter of MD135737)
 - Commercial tool (When using the oil filter of MD325714)
5. Clean the filter bracket side mounting surface, and make sure the O-ring is not left on the mounting surface.

6. Apply a small amount of new engine oil to the O-ring of the new oil filter.
7. Install the engine oil filter.

NOTE

Tightening torque:

When using the oil filter of MD135737: 14 Nm
(10 ft.lbs.)

When using the oil filter of MD325714: 16 Nm
(12 ft.lbs.)

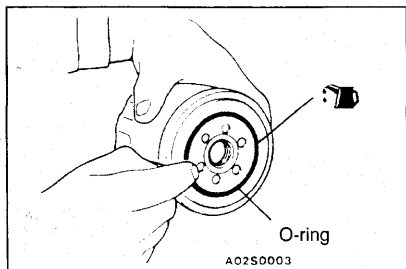

8. Install the drain plug and refill engine oil. (Refer to Engine Oil Replacement on P.00-38.)
9. Race the engine 2-3 times, and check to be sure that no engine oil leaks from installation section of the oil filter.

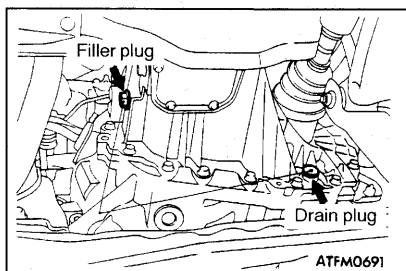
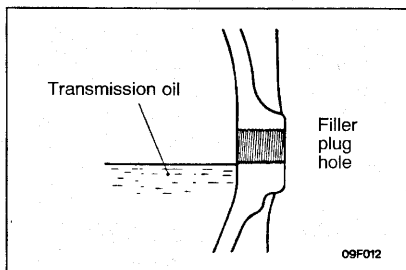

12. MANUAL TRANSAXLE

00100280161

Inspect oil level

Inspect each component for evidence of leakage, and check the oil level by removing the filler plug. If the oil is contaminated, it is necessary to replace it with new oil.

1. With the vehicle parked at a level place, remove the filler plug and check to be sure that the oil level is up to the lower edge of the filler plug hole.
2. Check to be sure that the transmission oil is not noticeably dirty, and that it has a suitable viscosity.

Change oil

1. Remove transaxle drain plug.
2. Drain oil.
3. Tighten drain plug to specified torque.

Tightening torque: 32 Nm (24 ft.lbs.)

4. Remove filler plug and fill with specified oil till the level comes to the lower portion of filler plug hole.

Specified oil:

Hypoid gear oil SAE 75W-90 or 75W-85W conforming to API classification GL-4

Quantity:

<F5M41> 2.1 dm³ (2.2 qts.)

<F5M42> 2.2 dm³ (2.3 qts.)

5. Tighten filler plug to specified torque.

Tightening torque: 32 Nm (24 ft.lbs.)

13. AUTOMATIC TRANSAXLE

00100290225

Check fluid level

1. Drive the vehicle until the fluid temperature rises to the normal temperature [70 - 80°C (158 - 176°F)].
2. Park the vehicle on a level surface.
3. Move the selector lever through all positions to fill the torque converter and the hydraulic circuits with fluid, and then move the selector lever to the N position.
4. After wiping off any dirt around the dipstick, remove the dipstick and check the condition of the fluid.

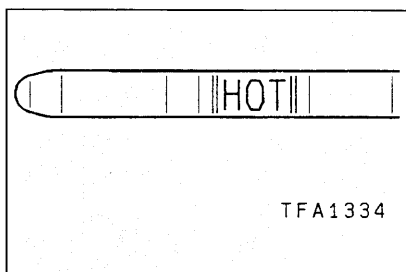

NOTE

If the fluid smells as if it is burning, it means that the fluid has been contaminated by fine particles from the bushes and friction materials, a transaxle overhaul and flashing the cooler line may be necessary.

5. Check that the fluid level is at the HOT mark on the dipstick. If the fluid level is lower than this, pour in more fluid until the level reaches the HOT mark.

Automatic transmission fluid:

Dia Queen ATF SP II, Dia Queen ATF SP II M or equivalent

NOTE

If the fluid level is low, the oil pump will draw in air along with the fluid, which will cause bubbles to form inside the hydraulic circuit. This will in turn cause the hydraulic pressure to drop, which will result in late shifting and slipping of the clutches and brakes.

If there is too much fluid, the gears can churn it up into foam and cause the same conditions that can occur with low fluid levels.

In either case, air bubbles can cause overheating and oxidation of the fluid which can interfere with normal valve, clutch, and brake operation. Foaming can also result in fluid escaping from the transaxle vent, in which case it may be mistaken for a leak.

6. Securely insert the dipstick.

NOTE

The fluid and oil filters should always be replaced under the following conditions:

When trouble shooting the transaxle

When overhauling the transaxle

When the oil is noticeably dirty or deteriorates (driving under the severe condition)

Furthermore, the oil filters are special filters which are only to be used for the automatic transaxle.

Change fluid

Drain the fluid and check whether there is any evidence of contamination.

Refill with new fluid after the cause of any contamination has been corrected.

Again, place vehicle at a level place.

If you have a fluid changer, use it to replace the fluid. If you do not have a fluid changer, replace the fluid by the following procedure.

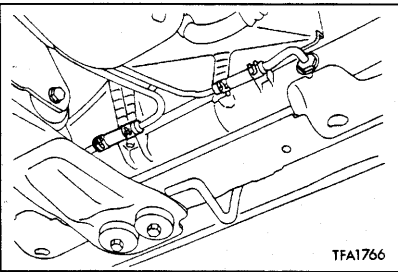

1. Disconnect the hose shown in the illustration which connects the transaxle and the oil cooler (inside the radiator).
2. Start the engine and let the fluid drain out.

Running conditions: N range with engine idling

Caution

The engine should be stopped within one minute after it is started. If the fluid has all drained out before then, the engine should be stopped at that point.

Discharge volume: Approx. 3.5 dm³ (3.7 qts.)

3. Remove the drain plug from the bottom of the transaxle case to drain the fluid.

Discharge volume: Approx. 2.0 dm³ (2.1 qts.)

4. Replace the oil filters.
5. Install the drain plug via the new gasket, and tighten it to the specified torque.

Tightening torque: 32 Nm (24 ft.lbs.)

6. Pour the new fluid in through the oil filler tube.

Adding volume: Approx. 5.5 dm³ (5.8 qts.)

Caution

Stop pouring if the specified volume of fluid cannot be poured in.

7. Repeat the procedure in step 2.

NOTE

Drain the fluid of at least 7.0 dm³ (7.4 qts.) from the cooler hose (during the work in both steps 2 and 7). Then drain the fluid a little and check the fluid for dirt. If it has been contaminated, repeat the steps 6 and 7.

8. Pour the new fluid in through the oil filler tube.

Adding volume: Approx. 3.5 dm³ (3.7 qts.)

9. Reconnect the hose which has been disconnected in step 1 above, and firmly replace the dipstick.
10. Start the engine and run it at idle for 1 - 2 minutes.
11. Move the selector lever through all positions, and then move it to the N position.

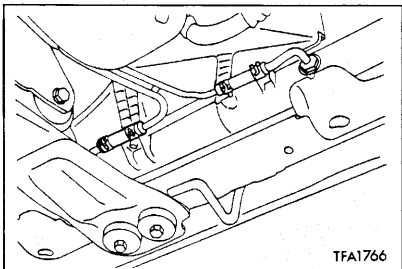
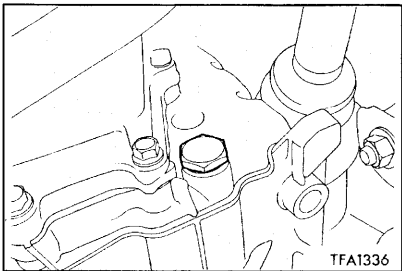



TFA1337

12. Check that the fluid level is at the COLD mark on the dipstick. If the level is lower than this, pour in more fluid.
13. Drive the vehicle until the fluid temperature rises to the normal temperature [70 - 80°C (158 - 176°F)], and then check the fluid level again.
The fluid level must be at the HOT mark.

NOTE

The COLD level is for reference only; the HOT level should be regarded as the standard level.

14. Firmly insert the dipstick into the oil filler tube.

14. ENGINE COOLANT (Change)

00100310181

Check the cooling system parts, such as the radiator, heater, and oil cooler hoses, thermostat and connections for leakage and damage.

Change coolant

1. Drain the engine coolant by removing the drain plug and then the radiator cap.

Caution

After the engine coolant temperature falls to 20°C (68°F), the engine coolant should be drained.

2. Remove the drain plug from the cylinder block to drain the engine coolant.
3. Open the air bleed bolt.
4. Remove the reserve tank to drain the engine coolant.
5. When the engine coolant has drained, pour in water, through the radiator cap to clean the engine coolant line.
6. Coat the thread of the cylinder block drain plug with the specified sealant and tighten to the specified torque.

Specified sealant:

3M Nut Locking Part No. 4171 or equivalent

7. Securely tighten the radiator drain plug.
8. Install the reserve tank.

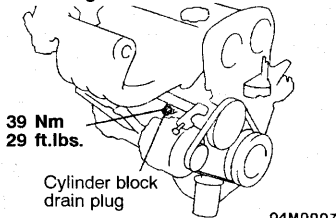
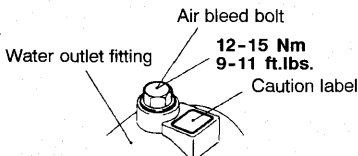
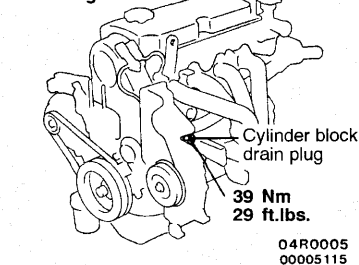
<1.5L Engine>**<1.8L Engine>**

A04X0065

9. Fill the radiator until the engine coolant flows from the air bleed bolt section, and then close the air bleed bolt.
10. Slowly pour the engine coolant into the mouth of the radiator until the radiator is full, and pour also into the reserve tank up to the FULL line.

Recommended antifreeze:

**DIA-QUEEN LONG-LIFE COOLANT (Part No. 0103044)
or High quality ethylene-glycol antifreeze coolant**

Quantity:<1.5L Engine> 5 dm³ (5.3 qts.)<1.8L Engine> 6 dm³ (6.3 qts.)

11. Install the radiator cap securely.
12. Start the engine and warm the engine until the thermostat opens. (Touch the radiator hose with your hand to check that warm water is flowing.)
13. After the thermostat opens, race the engine at 3,000 rpm 3 times.
14. After the engine is stopped, wait until the engine has cooled down, and then remove the radiator cap to check the level of the liquid. If the level is low, repeat the operation from step 11.
Lastly, if the level does not drop, fill the reserve tank with coolant up to the FULL line.

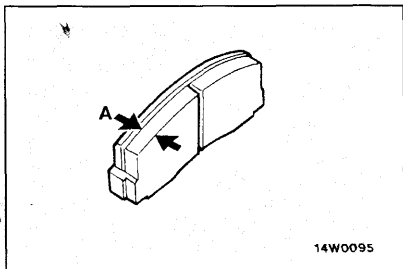
**15. DISC BRAKE PADS (Inspect for wear)** 00100320146

Check for fluid contamination and wear. Replace complete set of pads if defective.

Caution

The pads for the right and left wheels should always be replaced at the same time. Never "split" or intermix brake pad sets.

All four pads must be replaced as a complete set.

Thickness of lining (A)

Minimum limit: 2.0 mm (.08 in.)

16. REAR DRUM BRAKE LININGS AND REAR WHEEL CYLINDERS (Inspect for wear and leaks)

00100330088

1. Remove the brake drum and check the thickness of brake shoe lining for wear. Check the automatic brake adjusting system by hand to see if it operates smoothly. Also see if the gears are in proper mesh with each other. To assure smooth operation, apply a very thin coat of multipurpose grease to the friction surface of adjuster and link shaft.
2. Inspect the wheel cylinder boots for evidence of a brake fluid leak. Visually check the boots for cuts, tears or heat cracks. (A slight amount of fluid on the boot may not be a leak, but may be preservative fluid used at assembly.)
Checking the Brake Shoes for Wear.

Caution

Never split or intermix brake shoe sets.

All four shoes must be replaced as a complete set.

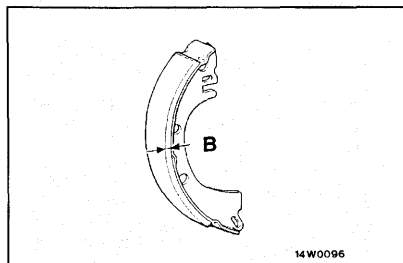

Thickness of lining (B)

Minimum limit: 1.0 mm (.04 in.)

17. BRAKE HOSES (Check for deterioration or leaks)

00100340135

Inspection of brake hoses and tubing should be included in all brake service operations.

The hoses should be checked for:

1. Correct length, severe surface cracking, pulling, scuffing or worn spots. (If the fabric casing of the hoses is exposed by cracks of abrasion in the rubber hose cover, the hoses should be replaced. Eventual deterioration of hose may occur with possible bursting failure.)
2. Faulty installation, casing twisting or interference with wheel, tire or chassis.

18. BALL JOINT AND STEERING LINKAGE SEALS (Inspect for grease leaks and damage)

00100350138

1. These components, which are permanently lubricated at the factory, do not require periodic lubrication. Damaged seals and boots should be replaced to prevent leakage or contamination of the grease.
2. Inspect the dust cover and boots for proper sealing, leakage and damage. Replace them if defective.

19. DRIVE SHAFT BOOTS (Inspect for grease leaks and damage)

00100360131

1. These components, which are permanently lubricated at the factory, do not require periodic lubrication. Damaged boots should be replaced to prevent leakage or contamination of the grease.
2. Inspect the boots for proper sealing, leakage and damage. Replace it if defective.

2-door models

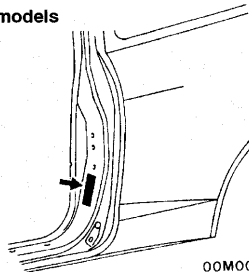

00M0054

4-door models

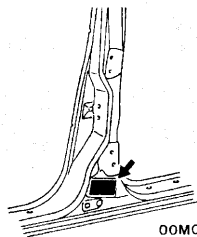

00M0055

Certification label Manufacture date

MADE IN U.S.A.		DATE APR, 1992	
MANUFACTURED BY DIAMOND-STAR MOTORS CORP.			
GVWR	LBS	CAWR	LBS
	KG	RR	KG
THIS VEHICLE CONFORMS TO ALL APPLICABLE FEDERAL MOTOR VEHICLE SAFETY, BUMPER AND THEFT PREVENTION STANDARDS IN EFFECT ON THE DATE OF MANUFACTURE SHOWN ABOVE.			
MDH		MUG00155	
VEHICLE TYPE: PASSENGER CAR			

00X0043
00005116

20. SRS AIR BAG SYSTEM (SRS component check: damage, function, connection to wiring harness, etc.)

00100370172

The SRS must be inspected by an authorized dealer 10 years after the car manufacture date shown on the certification label located on left center pillar.

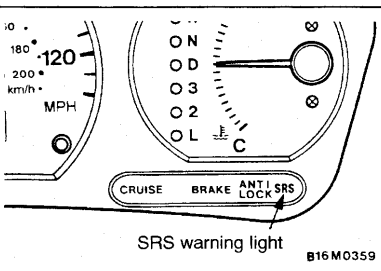

SRS warning light

B16M0359

“SRS” WARNING LIGHT CHECK

Turn the ignition key to the “ON” position. Does the “SRS” warning light illuminate for about 7 seconds, and then remain extinguished for at least 5 seconds after turning OFF? If yes, SRS system is functioning properly. If no, refer to GROUP 52B - Troubleshooting.

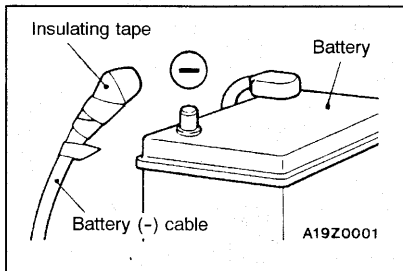

SRS COMPONENT VISUAL CHECK

Turn the ignition key to the "LOCK" position, disconnect the negative battery cable and tape the terminal.

Caution

Wait at least 60 seconds after disconnecting the battery cable before doing any further work.

The SRS system is designed to retain enough voltage to deploy the air bag for a short time even after the battery has been disconnected, so serious injury may result from unintended air bag deployment if work is done on the SRS system immediately after the battery cable is disconnected.

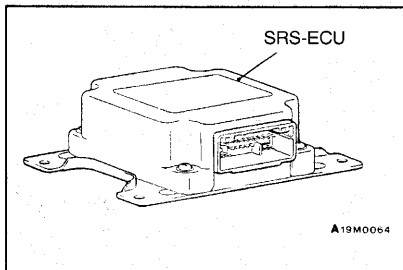

SRS AIR BAG CONTROL UNIT (SRS-ECU)

1. Check SRS-ECU case and brackets for dents, cracks, deformation or rust.

Caution

The SRS may not activate if the SRS-ECU is not installed properly, which could result in serious injury or death to the vehicle's driver or front passenger.

2. Check connector for damage, and terminals for deformation or rust.

Replace SRS-ECU if it fails visual check.

(Refer to GROUP 52B - SRS Air Bag Control Unit.)

<Driver's side>

Pad cover

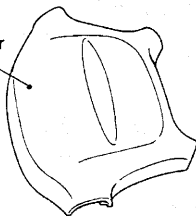

19S0239

<Front passenger's side>

Pad cover

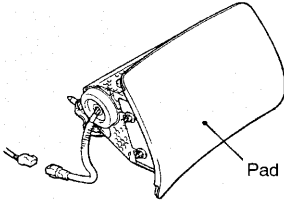
19M0093
00005117**AIR BAG MODULES, STEERING WHEEL AND CLOCK SPRING**

1. Remove the air bag modules, steering wheel and clock spring. (Refer to GROUP 52B - SRS Air Bag Modules and Clock Spring.)

Caution

The removed air bag modules should be stored in a clean, dry place with the pad cover facing up.

2. Check pad cover for dents, cracks or deformation.

<Driver's side>

Inflator case

Connector

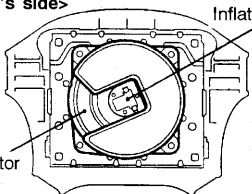

19M0146

<Front passenger's side>

Inflator case

Connector

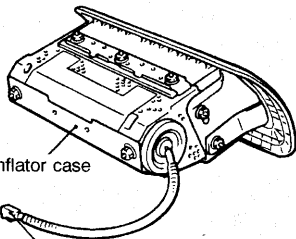
19M0022
00004825

3. Check connector for damage, terminals for deformation, and harness for binds.
4. Check air bag inflator case for dents, cracks or deformation.
5. Check harness (built into steering wheel) and connectors for damage, and terminals for deformation.

Protective tube

Case

Protective tube

Mating marks

A19S0331

6. Check clock spring connectors and protective tube for damage, and terminals for deformation.
7. Visually check the clock spring case for damage.
8. Align the mating marks of the clock spring and, after turning the vehicle's front wheels to straight-ahead position, install the clock spring to the column switch.

Mating Mark Alignment

Turn the clock spring clockwise fully, and then turn back it approx. 3 4/5 turns counterclockwise to align the mating marks.

Caution

If the clock spring's mating mark is not properly aligned, the steering wheel may not be completely rotational during a turn, or the flat cable within the clock spring may be severed, obstructing normal operation of the SRS and possibly leading to serious injury to the vehicle's driver or front passenger.

9. Install the steering column covers, steering wheel and the air bag module.
10. Check steering wheel for noise, binds or difficult operation.
11. Check steering wheel for excessive free play.
REPLACE ANY VISUALLY INSPECTED PART IF IT FAILS THAT INSPECTION. (Refer to GROUP 52B - SRS Air Bag Modules and Clock Spring.)

Caution

The SRS may not activate if any of the above components is not installed properly, which could result in serious injury or death to the vehicle's driver or front passenger.

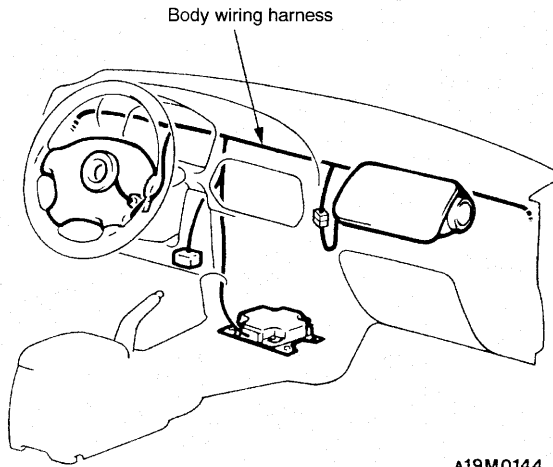
BODY WIRING HARNESS

1. Check connector for poor connection.
2. Check harnesses for binds, connectors for damage, and terminals for deformation.
REPLACE ANY CONNECTORS OR HARNESS THAT FAIL THE VISUAL INSPECTION. (Refer to GROUP 52B - SRS Service Precautions.)

Caution

The SRS may not activate if SRS harnesses or connectors are damaged or improperly connected, which could result in serious injury or death to the vehicle's driver or front passenger.

**21. EXHAUST SYSTEM (CONNECTION
PORTION OF MUFFLER, PIPINGS AND
CONVERTER HEAT SHIELDS) (Check and
service as required)**

00100580124

1. Check for holes and gas leaks due to damage, corrosion, etc.
2. Check the joints and connections for looseness and gas leaks.
3. Check the hanger rubber and brackets for damage.

MAIN SEALANT AND ADHESIVE TABLE

00100380021

SEALANTS FOR ENGINE ACCESSORIES

Application	Recommended brand
Sealing between rocker cover and camshaft bearing cap (4G6 DOHC and 6G7 engines only)	3M ATD Part No. 8660 or equivalent
Sealing between semi-circular packing and rocker cover and between semi-circular packing and cylinder head	
Oil pressure switch (except 4G1 and 6G7 engines)	
Engine coolant temperature switch, Engine coolant temperature sensor, Thermo valve, Thermo switch, Joints, Engine coolant temperature gauge unit (large size)	3M Nut Locking Part No. 4171 or equivalent
Engine coolant temperature gauge unit (small size, MD091056 only)	3M ATD Part No. 8660 or equivalent
Oil pan (except 4G5 engine)	MITSUBISHI GENUINE Part No. MD997110 or equivalent

SEALING BETWEEN GLASS AND WEATHERSTRIP

Application	Recommended brand
Sealing between tempered glass and weatherstrip	3M ATD Part No. 8513 or equivalent
Sealing between body flange and weatherstrip	3M ATD Part No. 8509 or equivalent
Sealing between laminated glass and weatherstrip	

ADHESION WITH RIBBON SEALER

Application	Recommended brand
Waterproof film for door, Fender panel, Splash shield, Mud guard, Rear combination light	3M ATD Part No. 8625 or equivalent

ADHESIVES FOR INTERIOR TRIM

Application	Recommended brand
Adhesion of polyvinyl chloride sheet	3M Part No. EC-1368 or equivalent
Adhesion of door weatherstrip to body	3M ATD Part No. 8001 or 3M ATD Part No. 8011 or equivalent
Sealing between grommet or packing, and metal seal	3M ATD Part No. 8513 or equivalent
Adhesion of headlining and other interior trim materials	3M Part No. EC-1368 or 3M ATD Part No. 8080 or equivalent
Adhesion of fuel tank to pad	

BODY SEALANT

Application	Recommended brand
Sealing of sheet metal, drip rail, floor, body side panel, trunk, front panel and the like joints	3M ATD Part No. 8531 or 3M ATD Part No. 8646 or equivalent
Sealing of liftgate hinges	

CHASSIS SEALANT

Application	Recommended brand
Sealing of flange surfaces and threaded portions	3M ATD Part No. 8659 or equivalent
Fuel gauge unit packing	
Sealing of flange surfaces, threaded portions, packing and dust cover <ul style="list-style-type: none"> ● Differential carrier packing ● Dust covers for ball joint and linkage ● Steering gear box packing and shims ● Steering gear housing rack support cover and top cover ● Mating surface of knuckle arm flange 	3M ATD Part No. 8663 or equivalent
Sealing between accelerator arm bracket and firewall	Drying sealant
Sealant for drum brake shoe hold-down pin and wheel cylinder	3M ATD Part No. 8513 or equivalent

FAST BONDING ADHESIVE

Application	Recommended brand
Adhesion of all materials except polyethylene, polypropylene, fluorocarbon resin or other materials with highly absorbent surface	3M ATD Part No. 8155 or equivalent

ANAEROBIC FAST BONDING ADHESIVE

Application	Recommended brand
Fixing of bolts and screws <ul style="list-style-type: none"> ● Tightening of drive gear to differential case ● Bolts for coupling tilt steering upper column with lower column 	3M Stud locking Part No. 4170 or equivalent
Fixing of bearing, fan, pulley and gear connections	
Sealing of small recess or flange surface	
Steering angle stopper bolt	3M Nut locking Part No.4171 or equivalent

UNDERCOAT

Application	Recommended brand
Undercoat	3M ATD Part No. 8864 or equivalent