GROUP 22A

**MANUAL
TRANSMISSION**

CONTENTS

| | | | |
|--------------------------------------|--------------|---------------------------------------|--------------|
| MANUAL TRANSMISSION | 22A-2 | TRANSMISSION CONTROL | 22A-3 |
| GENERAL INFORMATION | 22A-2 | GENERAL INFORMATION | 22A-3 |

MANUAL TRANSMISSION

GENERAL INFORMATION

M2220000100183

- Newly developed 5-speed manual transmission (Manufactured by GETRAG).
- Compact and light weight design with torque capacity 140 N·m (cover to 135950 engine) makes contribute to high-level fuel consumption and passive safety.
- Transmission oil is "fill for life" for maintenance free.
- 6-speed automated manual transmission is designed based on this 5M/T.

SPECIFICATIONS

| Item | | Specification | |
|-------------------------|----------------------|--|------------|
| Transmission model | | F5MGA-1-30 | F5MGA-1-33 |
| Engine model | | 134 | 135 |
| Transmission type | | 5-speed forward, 1-speed reverse | |
| Transmission gear ratio | 1st | 3.308 | 3.308 |
| | 2nd | 1.913 | 1.913 |
| | 3rd | 1.258 | 1.258 |
| | 4th | 0.943 | 0.943 |
| | 5th | 0.763 | 0.763 |
| | Reverse | 3.231 | 3.231 |
| Final reduction ration | | 4.353 | 4.158 |
| Transmission oil | Specified lubricants | Castrol/Burmach gear oil BOT 328 (or exact equivalent) | |
| | Quantity L | 1.75 | |

SECTIONAL VIEW

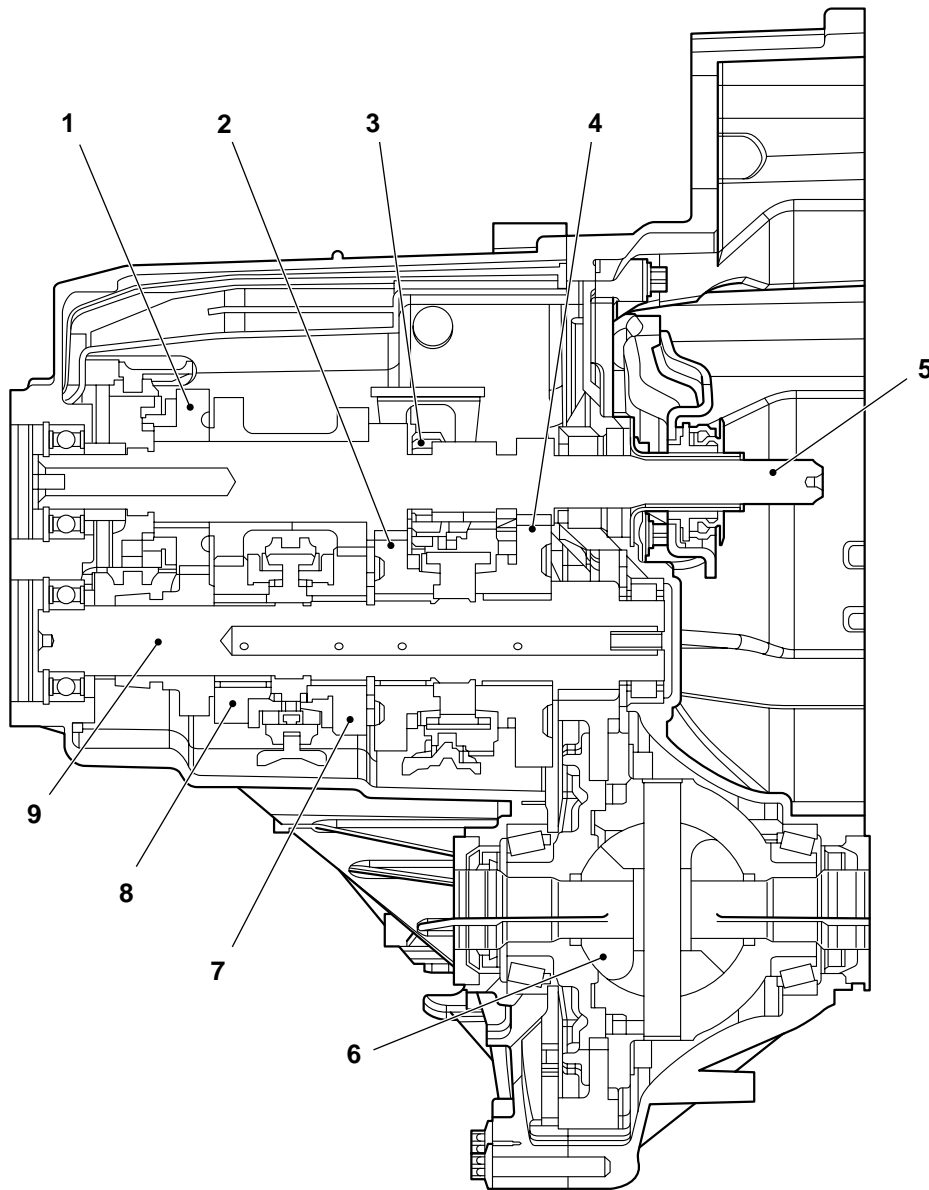

1. 5th gear
2. 2nd gear
3. Reverse gear
4. 1st gear
5. Input shaft

6. Differential
7. 3rd gear
8. 4th gear
9. Output shaft

AC311790AB

TRANSMISSION CONTROL

GENERAL INFORMATION

M2222000100060

- Gear shift control is 2 cables remote control type.
- Well balanced shift by select travel, combined with newly developed synchronizer provides smooth and delightful shift feeling.

- Gearshift knob with silver colour decoration cap and collar tube gives one grade higher appearance.

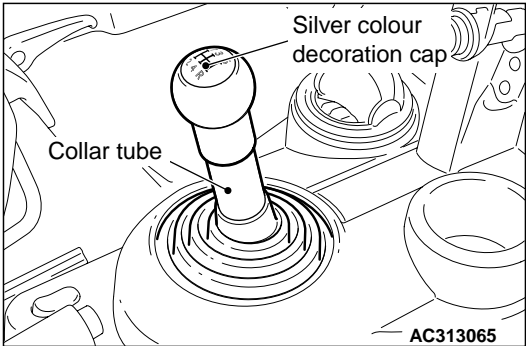
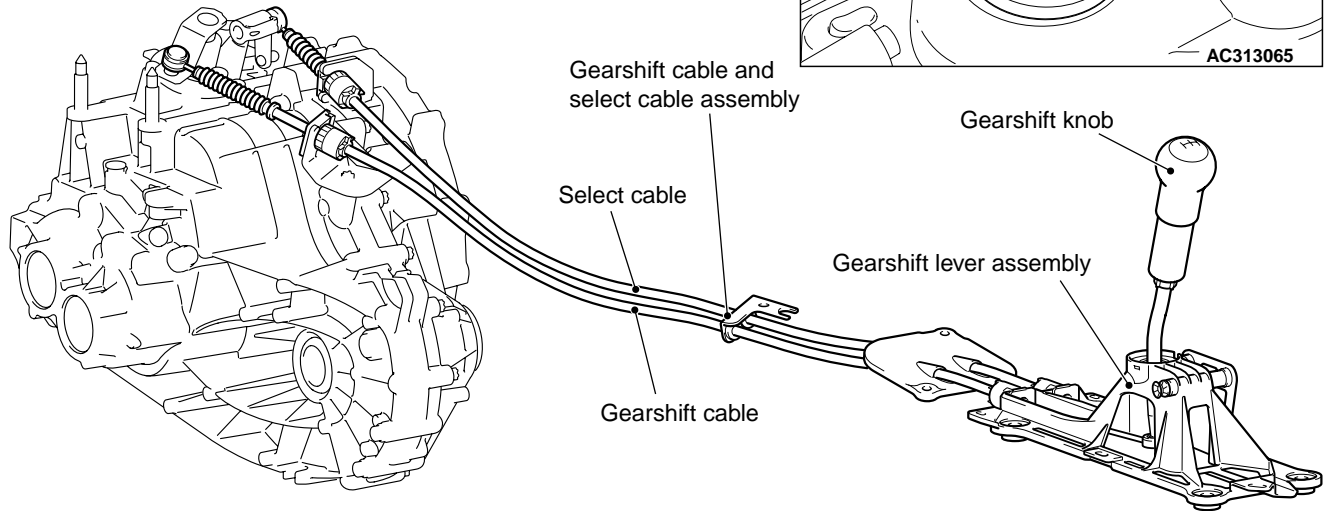

AC313250AB