

GROUP 13A

MULTIPOINT FUEL INJECTION (MPI) <4G1>

CONTENTS

GENERAL INFORMATION	13A-2	BASIC IDLE SPEED ADJUSTMENT	13A-399
SERVICE SPECIFICATIONS	13A-5	FUEL PRESSURE TEST	13A-399
SEALANT	13A-5	FUEL PUMP CONNECTOR DISCONNECTION (HOW TO REDUCE PRESSURIZED FUEL LINES)	13A-401
SPECIAL TOOLS	13A-6	FUEL PUMP OPERATION CHECK	13A-402
TROUBLESHOOTING	13A-9	COMPONENT LOCATION	13A-403
DIAGNOSIS TROUBLESHOOTING FLOW	13A-9	ENGINE CONTROL RELAY CONTINUITY CHECK	13A-404
DIAGNOSIS FUNCTION	13A-9	FUEL PUMP RELAY CONTINUITY CHECK	13A-404
INSPECTION CHART FOR DIAGNOSIS CODE	13A-17	INTAKE AIR TEMPERATURE SENSOR CHECK	13A-404
INSPECTION PROCEDURE FOR DIAGNOSIS CODES	13A-18	ENGINE COOLANT TEMPERATURE SENSOR CHECK	13A-405
INSPECTION CHART FOR TROUBLE SYMPTOMS	13A-233	THROTTLE POSITION SENSOR CHECK .	13A-406
SYMPTOM PROCEDURES	13A-237	OXYGEN SENSOR CHECK	13A-406
DATA LIST REFERENCE TABLE	13A-376	INJECTOR CHECK	13A-407
ACTUATOR TEST REFERENCE TABLE ..	13A-383	IDLE SPEED CONTROL (ISC) SERVO (STEPPER MOTOR) CHECK	13A-408
CHECK AT THE ECU TERMINALS	13A-384	INJECTOR	13A-410
INSPECTION PROCEDURE USING OSCILLOSCOPE	13A-391	REMOVAL AND INSTALLATION	13A-410
ON-VEHICLE SERVICE	13A-398	THROTTLE BODY ASSEMBLY	13A-412
THROTTLE BODY (THROTTLE VALVE AREA) CLEANING	13A-398	REMOVAL AND INSTALLATION	13A-412
THROTTLE POSITION SENSOR ADJUSTMENT	13A-398	ENGINE-ECU AND ENGINE- A/T-ECU	13A-413
		REMOVAL AND INSTALLATION	13A-413

GENERAL INFORMATION

M1131000101867

The Multipoint Fuel Injection System consists of sensors which detect the engine conditions, the engine-ECU <M/T> or engine-A/T-ECU <A/T> which controls the system based on signals from these sensors, and actuators which operate under the control of the engine-ECU <M/T> or engine-A/T-ECU <A/T>. The engine-ECU <M/T> or engine-A/T-ECU

FUEL INJECTION CONTROL

The injector drive times and injection timing are controlled so that the optimum air/fuel mixture is supplied to the engine to correspond to the continually-changing engine operation conditions.

A single injector is mounted at the intake port of each cylinder. Fuel is sent under pressure from the fuel tank by the fuel pump, with the pressure being regulated by the fuel pressure regulator. The fuel thus regulated is distributed to each of the injectors.

Fuel injection is normally carried out once for each cylinder for every two rotations of the crankshaft. The firing order is 1-3-4-2. This is called sequential fuel injection. The engine-ECU <M/T> or engine-A/T-ECU <A/T> provides a richer air/fuel mix-

IDLE SPEED CONTROL

The idle speed is kept at the optimum speed by controlling the amount of air that bypasses the throttle valve in accordance with changes in idling conditions and engine load during idling. The engine-ECU <M/T> or engine-A/T-ECU <A/T> drives the idle speed control motor to keep the engine running at the pre-set idle target speed in accordance with the

IGNITION TIMING CONTROL

The power transistor located in the ignition primary circuit turns ON and OFF to control the primary current flow to the ignition coil. This controls the ignition timing in order to provide the optimum ignition timing with respect to the engine operating conditions. The ignition timing is determined by the engine-ECU <M/T> or engine-A/T-ECU <A/T> from the engine speed, intake air volume, engine coolant temperature and atmospheric pressure.

SELF-DIAGNOSIS FUNCTION

- When an abnormality is detected in one of the sensors or actuators related to emission control, the engine warning lamp (check engine lamp) illuminates as a warning to the driver.
- When an abnormality is detected in one of the sensors or actuators, a diagnosis code corresponding to the abnormality is output.
- The RAM data inside the engine-ECU <M/T> or engine-A/T-ECU <A/T> that is related to the sensors and actuators can be read by means of the M.U.T.-II/III. In addition, the actuators can be force-driven under certain circumstances.

<A/T> carries out activities such as fuel injection control, idle speed control and ignition timing control. In addition, the engine-ECU <M/T> or engine-A/T-ECU <A/T> is equipped with several diagnosis modes which simplify troubleshooting when a problem develops.

ture by carrying out "open-loop" control when the engine is cold or operating under high load conditions in order to maintain engine performance. In addition, when the engine is warm or operating under normal conditions, the engine-ECU <M/T> or engine-A/T-ECU <A/T> controls the air/fuel mixture by using the oxygen sensor signal to carry out "closed-loop" control in order to obtain the theoretical air/fuel mixture ratio that provides the maximum cleaning performance from the three way catalyst.

engine coolant temperature and air conditioner load. In addition, when the air conditioner switch is turned off and on while the engine is idling, the idle speed control motor operates to adjust the throttle valve bypass air amount in accordance with the engine load conditions in order to avoid fluctuations in the engine speed.

OTHER CONTROL FUNCTIONS

1. Fuel Pump Control
Turns the fuel pump relay ON so that current is supplied to the fuel pump while the engine is cranking or running.
2. A/C Relay Control
Turns the compressor clutch of the A/C ON and OFF.
3. Fan Motor Control
The revolutions of the radiator fan and condenser fan are controlled in response to the engine coolant temperature and vehicle speed.
4. Purge Control Solenoid Valve Control
(Refer to P.17-9, GROUP 17 –Engine And Emission Control –Evaporative Emission Control System).
5. EGR Control Solenoid Valve Control
[Refer to P.17-13, GROUP 17 –Engine And Emission Control – Exhaust Gas Recirculation (EGR) System].

GENERAL SPECIFICATIONS

Items		Specifications
Throttle body	Throttle bore mm	45 <4G13> 50 <4G18>
	Throttle position sensor	Variable resistor type
	Idle speed control servo	Stepper motor type
Engine-ECU <M/T>	Identification No.	E6T41771 <4G13> E6T41772 <4G18>
Engine-A/T-ECU <A/T>	Identification No.	E6T37783
Sensors	Manifold absolute pressure sensor	Semiconductor type
	Intake air temperature sensor	Thermistor type
	Engine coolant temperature	Thermistor type
	Oxygen sensor	Zirconia type
	Inhibitor switch <A/T>	Contact switch type
	Vehicle speed sensor <M/T>	Magnetic resistive element type
	Camshaft position sensor	Hall element type
	Crank angle sensor	Hall element type
	Detonation sensor	Piezoelectric type
	Power steering fluid pressure switch	Contact switch type
Actuators	Engine control relay	Contact switch type
	Fuel pump relay	Contact switch type
	Injector type and number	Electromagnetic type, 4
	Injector identification mark	CDH 166 <4G13> CDH 210 <4G18>
	EGR control solenoid valve	Duty cycle type solenoid valve
	Purge control solenoid valve	Duty cycle type solenoid valve
Fuel pressure regulator	Regulator pressure kPa	329

MULTI-POINT FUEL INJECTION SYSTEM DIAGRAM

<ul style="list-style-type: none"> ★ 1 Oxygen sensor (front) ★ 2 Intake air temperature sensor ★ 3 Throttle position sensor ★ 4 Camshaft position sensor ★ 5 Crank angle sensor ★ 6 Manifold absolute pressure sensor ★ 7 Engine coolant temperature sensor ★ 8 Detonation sensor ★ 9 Oxygen sensor (rear) 	<ul style="list-style-type: none"> ● Power supply ● Ignition switch-IG ● Ignition switch-ST ● A/C switch ● A/C load signal ● Power steering fluid pressure switch ● Alternator FR terminal ● Vehicle speed sensor <M/T> ● Inhibitor switch <A/T> 	⇒ Engine-ECU <M/T> or Engine-A/T-ECU <A/T> ⇒	<ul style="list-style-type: none"> ★ 1 Injector ★ 2 Idle speed control servo (Stepper motor) ★ 3 EGR control solenoid valve ★ 4 Purge control solenoid valve 	<ul style="list-style-type: none"> ● Engine control relay ● Fuel pump relay ● A/C compressor relay ● Ignition coil ● Fan controller ● Engine warning lamp ● Diagnosis output ● Alternator G terminal ● Oxygen sensor heater ● Tachometer
---	---	--	--	--

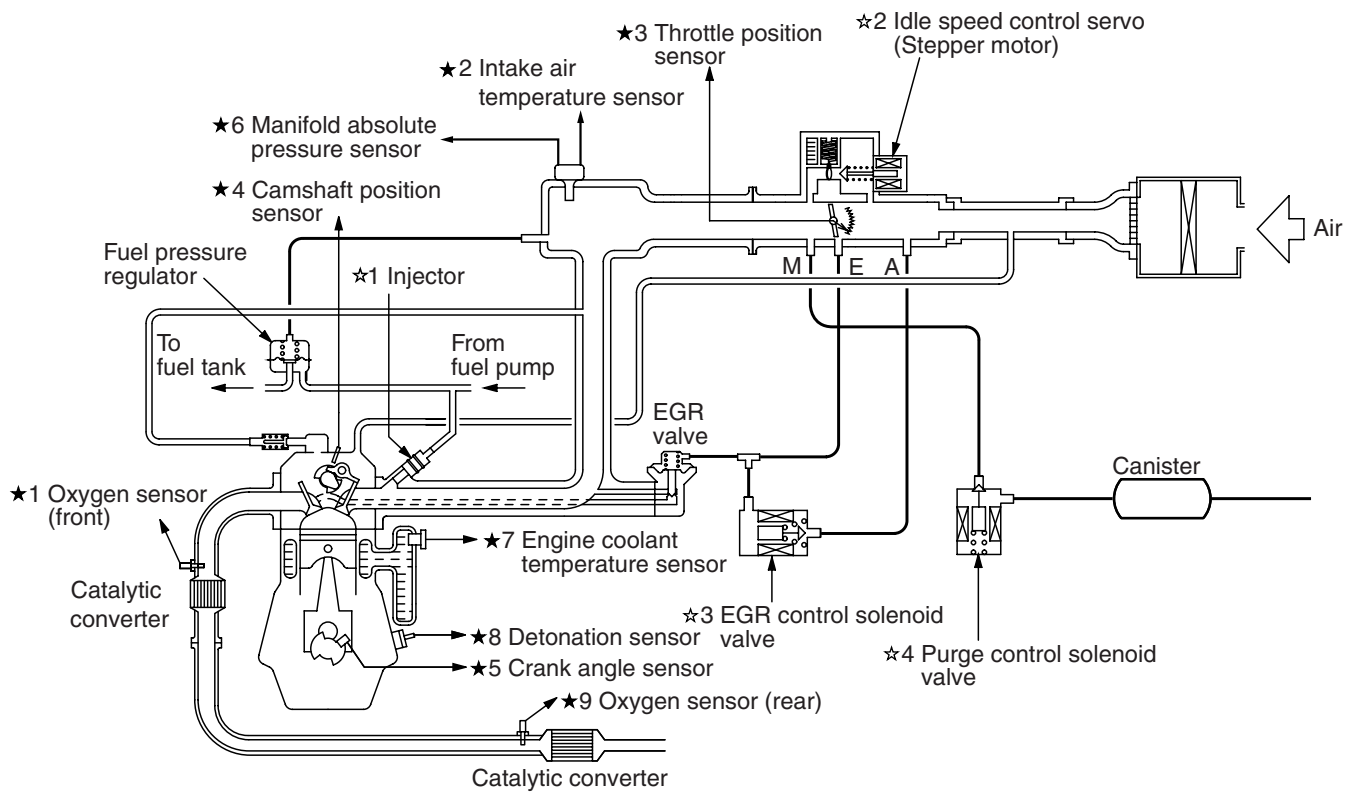

SERVICE SPECIFICATIONS

M1131000300590

Items		Specifications
Basic idle speed r/min		750 ± 50
Throttle position sensor adjusting voltage mV		335 – 935
Throttle position sensor resistance kΩ		2.0 – 4.0
Idle speed control servo coil resistance (at 20° C) Ω		28 – 33
Intake air temperature sensor resistance kΩ	-20° C	13 – 17
	0° C	5.3 – 6.7
	20° C	2.3 – 3.0
	40° C	1.0 – 1.5
	60° C	0.56 – 0.76
	80° C	0.30 – 0.42
Engine coolant temperature sensor resistance kΩ	-20° C	14 – 17
	0° C	5.1 – 6.5
	20° C	2.1 – 2.7
	40° C	0.9 – 1.3
	60° C	0.48 – 0.68
	80° C	0.26 – 0.36
Oxygen sensor output voltage (at racing) V		0.6 – 1.0
Oxygen sensor heater resistance (at 20° C) Ω	front	4.5 – 8.0
	rear	4.5 – 8.0
Fuel pressure kPa	Vacuum hose disconnection	324 – 343 at curb idle
	Vacuum hose connection	Approximately 265 at curb idle
Injector coil resistance (at 20° C) Ω		13 – 16





SEALANT



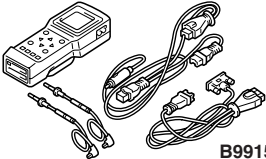
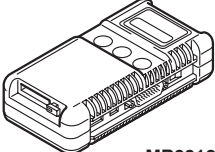

M1131000500356

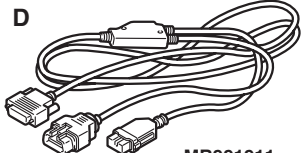
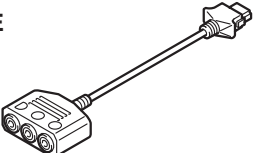
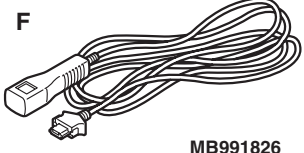

Item	Specified sealant	Remark
Engine coolant temperature sensor Threaded portion	3M Nut Locking Part No. 4171 or equivalent	Drying sealant

SPECIAL TOOLS

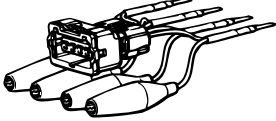
M1131000600513

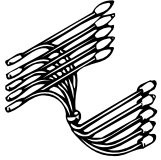
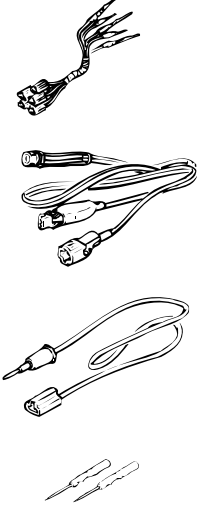
Tool	Number	Name	Use
 <p>B991502</p>	MB991502	M.U.T.-II sub assembly	<ul style="list-style-type: none"> • Reading diagnosis code • MPI system inspection • Measurement of fuel pressure
<p>A</p>  <p>MB991824</p> <p>B</p>  <p>MB991827</p> <p>C</p>  <p>MB991910</p> <p>D</p>  <p>MB991911</p> <p>E</p>  <p>MB991825</p> <p>F</p>  <p>MB991826</p> <p>MB991955</p>	<p>MB991955</p> <p>A: MB991824 B: MB991827 C: MB991910 D: MB991911 E: MB991825 F: MB991826</p> <p>M.U.T.-III sub assembly</p> <p>A: Vehicle communication interface (V.C.I.) B: M.U.T.-III USB cable C: M.U.T.-III main harness A (Vehicles with CAN communication system) D: M.U.T.-III main harness B (Vehicles without CAN communication system) E: M.U.T.-III measurement adapter F: M.U.T.-III trigger harness</p>	M.U.T.-III sub assembly	<ul style="list-style-type: none"> • Reading diagnosis code • MPI system inspection • Measurement of fuel pressure
 <p>MB991348</p>	MB991348	Test harness set	<ul style="list-style-type: none"> • Measurement of voltage during troubleshooting • Inspection using an oscilloscope

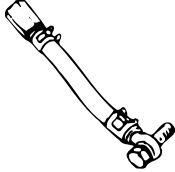
Tool	Number	Name	Use
	MB991709	Test harness	<ul style="list-style-type: none"> • Measurement of voltage during troubleshooting • Inspection using an oscilloscope • Check of idle speed control servo
	MD998478	Test harness (3-pin, triangle)	<ul style="list-style-type: none"> • Measurement of voltage during Troubleshooting • Inspection using an oscilloscope
 <p data-bbox="358 793 456 814">MB991536</p>	MB991536	Check harness for throttle position sensor adjustment	<ul style="list-style-type: none"> • Measurement of voltage during Troubleshooting • Adjusting of throttle position sensor
	MD998464	Test harness (4-pin, square)	<ul style="list-style-type: none"> • Measurement of voltage during Troubleshooting • Inspection of oxygen sensor (front)
 <p data-bbox="350 1224 448 1245">MB991658</p>	MB991658	Test harness	<ul style="list-style-type: none"> • Measurement of voltage during Troubleshooting • Inspection of oxygen sensor (rear)
 <p data-bbox="337 1812 435 1833">MB991223</p>	MB991223 A: MB991219 B: MB991220 C: MB991221 D: MB991222	Harness set A: Test harness B: LED harness C: LED harness adapter D: Probe	<ul style="list-style-type: none"> • Check at the ECU terminals A: Connector pin contact inspection B: Power circuit inspection C: Power circuit inspection D: Commercial tester connection

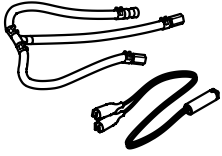
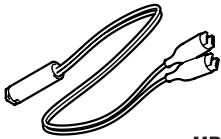
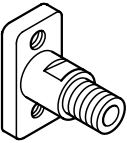
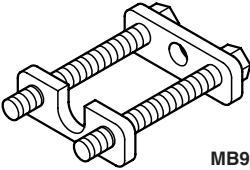
Tool	Number	Name	Use
	MD998709	Adaptor hose	Measurement of fuel pressure
	MD998742	Hose adaptor	
 <p data-bbox="362 789 456 810">MB991637</p>	MB991637	Fuel pressure gauge set	
 <p data-bbox="362 995 456 1016">MD998706</p>	MD998706	Injector test set	Checking the spray condition of injectors
 <p data-bbox="362 1197 456 1218">MB991607</p>	MB991607	Injector test harness	
 <p data-bbox="362 1402 456 1423">MD998741</p>	MD998741	Injector test adaptor	
 <p data-bbox="362 1608 456 1629">MB991976</p>	MB991976	Injector test holder assembly	

TROUBLESHOOTING

DIAGNOSIS TROUBLESHOOTING FLOW

Refer to P.00-5, GROUP 00 –How to Use Troubleshooting/Inspection Service Points.

NOTE: If the engine-ECU <M/T> or engine-A/T-ECU <A/T> is replaced, ring antenna with built in immobilizer-ECU should be replaced, ignition key can be kept, but must be registered.

DIAGNOSIS FUNCTION

M113115000502

M1131155500148

ENGINE WARNING LAMP (CHECK ENGINE LAMP)

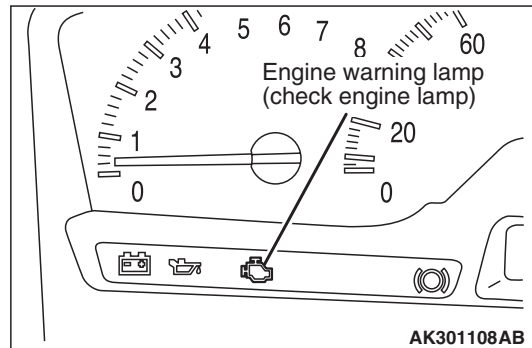

If an abnormality occurs in any of the following items related to the Multipoint Fuel Injection (MPI) system, the engine warning lamp will illuminate.

If the lamp remains illuminated or if the lamp illuminates while the engine is running, check the diagnosis code output.

ENGINE WARNING LAMP INSPECTION ITEMS

Code No.	Diagnosis item
–	Engine-ECU<M/T> or engine-A/T-ECU<A/T>
P0105	Manifold absolute pressure sensor system
P0110	Intake air temperature sensor system
P0115	Engine coolant temperature sensor system
P0120	Throttle position sensor system
P0125*	Feedback system monitor
P0130	Oxygen sensor (front) system <sensor 1>
P0135	Oxygen sensor heater (front) system <sensor 1>
P0136	Oxygen sensor (rear) system <sensor 2>
P0141	Oxygen sensor heater (rear) system <sensor 2>
P0170	Abnormal fuel system
P0201	No. 1 injector system
P0202	No. 2 injector system
P0203	No. 3 injector system
P0204	No. 4 injector system
P0300	Random cylinder misfire detection system
P0301*	No. 1 cylinder misfire detection system
P0302*	No. 2 cylinder misfire detection system
P0303*	No. 3 cylinder misfire detection system
P0304*	No. 4 cylinder misfire detection system

Code No.	Diagnosis item
P0325	Detonation sensor system
P0335	Crank angle sensor system
P0340	Camshaft position sensor system
P0403	EGR control solenoid valve system
P0421	Warm up catalyst malfunction
P0443	Purge control solenoid valve system
P0500	Vehicle speed sensor system <M/T>
P0505	Idle speed control system
P0513	Immobilizer system
P0551*	Power steering fluid pressure switch system
P1603*	Battery back-up line system

NOTE:

- If the engine warning lamp illuminates because of a malfunction of the engine-ECU <M/T> or engine-A/T-ECU <A/T>, communication between M.U.T.-II/III and the engine-ECU <M/T> or engine-A/T-ECU <A/T> is impossible. In this case, the diagnosis code cannot be read.
- After the engine-ECU <M/T> or engine-A/T-ECU <A/T> has detected a malfunction, the engine warning lamp illuminates when the engine is next turned on and the same malfunction is re-detected. However, for items marked with a "*" in the diagnosis code number column, the engine warning lamp illuminates only on the first detection of the malfunction.
- After the engine warning lamp illuminates, it will be switched off under the following conditions.
 - When the engine-ECU <M/T> or engine-A/T-ECU <A/T> monitored the power train malfunction three times* met set condition requirements, it detected no malfunction.
- *: In this case, "one time" indicates from engine start to stop.
 - For misfiring malfunction, when driving conditions (engine speed, engine coolant temperature, etc.) are similar to those when the malfunction was first recorded.
- Sensor 1 indicates, the sensor mounted at a position closest to the engine, and sensor 2 indicates the sensor mounted at the position second closest to the engine.

METHOD OF READING AND ERASING DIAGNOSIS CODES

Refer to P.00-5, GROUP 00 –How to Use Troubleshooting/Inspection Service Points

DIAGNOSIS USING DIAGNOSIS 2 MODE

1. Switch the diagnosis mode of the engine control unit to DIAGNOSIS 2 mode using the M.U.T.-II/III.
2. Carry out a road test.
3. Take a reading of the diagnosis code and repair the problem location.
4. Turn the ignition switch to "LOCK (OFF)" position and then back to "ON" position again.

NOTE: By turning the ignition switch to "LOCK (OFF)" position, the ENGINE-ECU <M/T> or ENGINE-A/T-ECU <A/T> will switch the diagnosis mode from DIAGNOSIS 2 mode to DIAGNOSIS 1 mode.

5. Erase the diagnosis codes.

INSPECTION USING M.U.T.-II/III DATA LIST AND ACTUATOR TESTING

1. Carry out inspection by means of the data list and the actuator test function, if there is an abnormality, check and repair the chassis harness and components.
2. After repairing, re-check using the M.U.T.-II/III and check that the abnormal input and output have returned to normal as a result of the repairs.
3. Erase the diagnosis code memory.
4. Remove the M.U.T.-II/III, and then start the engine again and carry out a road test to confirm that the problem has disappeared.

FREEZE FRAME DATA

When the engine-ECU <M/T> or engine-A/T-ECU <A/T> detects a malfunction and stores a diagnosis code, it also stores a current status of the engine. This function is called "Freeze frame data". By analyzing this "Freeze frame" data with the M.U.T.-II/III, an effective troubleshooting can be performed. The display items of freeze frame data are shown below.

DISPLAY ITEM LIST

Item No.	Data	Unit	
21	Engine coolant temperature sensor	°C	
22	Engine speed	r/min	
24	Vehicle speed	km/h	
80	Long-term fuel compensation (long-term fuel trim)	%	
82	Short-term fuel compensation (short-term fuel trim)	%	
88	Fuel control condition	Open loop	OL
		Closed loop	CL
		Open loop owing to drive condition	OL-DRV.
		Open loop owing to system malfunction	OL-SYS.
		Closed loop based on one oxygen sensor	CL- HO2S
87	Calculation load value	%	
	Diagnosis code during data recording	-	

NOTE: If malfunctions have been detected in multiple systems, store one malfunction only, which has been detected first.

DRIVE CYCLE

By carrying out the test drive in the following three drive cycle patterns, the all monitoring can be accomplished for the diagnosis codes that is required by the vehicle driving to identify the fault. In other words, doing such a drive allows to regenerate any kind of trouble which involves illuminating the engine warning lamp (check engine lamp) and to verify the repair procedure has eliminated the trouble [the engine warning lamp (check engine lamp) is no longer illuminated].

⚠ CAUTION

Two technicians should always be in the vehicle when carrying out a test drive.

NOTE: Check that the diagnosis code is not output before traveling in the Drive cycle pattern. Erase the diagnosis code if it has been output.

DRIVE CYCLE PATTERN LIST

Procedure	Monitor item	Diagnosis code
1	Catalytic converter monitor	P0421
2	Oxygen sensor (front) monitor	P0130
3	Other monitor	P0136, P0201, P0202, P0203, P0204, P0300, P0301, P0302, P0303, P0304, P0325, P0500 <M/T>, P0551

Procedure 1

Catalytic converter monitor	
Diagnosis code No.	P0421
Drive cycle pattern	<p>One trip monitor [from start to ignition switch to "LOCK" (OFF) position] will be completed while traveling with the following drive cycle pattern. It will take 16 minutes or more.</p> <p style="text-align: right;">AK301815AB</p>
Inspection condition	<ul style="list-style-type: none"> • Atmospheric temperature: -10°C or more • Condition of A/T: Selector lever D range, overdrive switch "ON" position
Test procedure	<ol style="list-style-type: none"> 1. Engine: start 2. Accelerate until the vehicle speed is 90 km/h or more. 3. Travel for 6 minutes or more while keeping the vehicle speed at 90 km/h or more. 4. Decelerate until the vehicle speed is within 80 km/h or less. 5. While traveling at 55 – 80 km/h for 10 minutes or more, fully close the throttle at least once in 2 minutes and decelerate for 10 seconds or more. <ul style="list-style-type: none"> • Do not repeat deceleration too often. • Vehicle speed may go below 55 km/h after the deceleration. • Stopping and braking are permitted. (If stopped or drive at 55 km/h or less for more than 5 minutes the monitoring may be stopped. In this case please restart monitoring from the beginning.) 6. After completing the above deceleration, bring the vehicle speed back to 55 – 80 km/h and keep it in the range until starting the deceleration again. <ul style="list-style-type: none"> • Repeat the above deceleration at least 5 times. 7. Return the vehicle to the shop, then turn the ignition switch to "LOCK" (OFF) position.

Procedure 2

Oxygen sensor (front) monitor	
Diagnosis code No.	P0130
Drive cycle pattern	<p>One trip monitor [from start to ignition switch to "LOCK" (OFF) position] will be completed while traveling with the following drive cycle pattern. It will take 16 minutes or more.</p> <p style="text-align: right;">AK301816AB</p>
Inspection conditions	<ul style="list-style-type: none"> • Engine coolant temperature: After engine warm up • Atmospheric temperature: – 10° C or more • Condition of A/T: Selector lever D range, overdrive switch "ON" position
Test procedure	<ol style="list-style-type: none"> 1. Engine: start 2. Accelerate until the vehicle speed is 55 – 80 km/h. 3. While keeping the accelerator pedal opening degree constant, keep the vehicle speed at 55 – 80km/h and travel for 16 minutes or more. <ul style="list-style-type: none"> • Stopping and braking during this operation are permitted. 4. Return the vehicle to the shop, then turn the ignition switch to "LOCK" (OFF) position.

Procedure 3

Other monitor	
Diagnosis code No.	P0136, P0201, P0202, P0203, P0204, P0300, P0301, P0302, P0303, P0304, P0325, P0500 <M/T>, P0551
Drive cycle pattern	<p>One trip monitor [from start to ignition switch to "LOCK" (OFF) position] will be completed while traveling with the following drive cycle pattern. It will take 21 minutes or more.</p> <p style="text-align: right;">AK301817AB</p>
Inspection conditions	<ul style="list-style-type: none"> • Engine coolant temperature: After engine warm up • Atmospheric temperature: -10° C or more • Condition of A/T: Selector lever D range, overdrive switch "ON" position
Test procedure	<ol style="list-style-type: none"> 1. Engine: start 2. Accelerate until the vehicle speed is 55 km/h. 3. While keeping the accelerator pedal opening degree constant, keep the vehicle speed at 55 km/h and travel for 16 minutes or more. 4. Return the vehicle to the shop. 5. After stopping the vehicle, continue idling for 5 minutes, and then turn the ignition switch to "LOCK" (OFF) position.

READINESS TEST STATUS

The engine-ECU <M/T> or engine-A/T-ECU <A/T> monitors the following main diagnosis items, judges if these items are in good condition or not, and the stores its history. this history can be read out by using M.U.T.-II/III. (If the ECU has judged a item before, the M.U.T.-II/III displays "Complete").

In addition, if diagnosis codes are erased or the battery cable is disconnected, this history will also be erased (the memory will be reset).

- Catalyst: P0421
- Oxygen sensor: P0130
- Oxygen sensor heater: P0135, P0141

FAIL-SAFE FUNCTION REFERENCE TABLE

When the main sensor malfunctions are detected by the diagnosis function, the vehicle is controlled by means of the pre-set control logic to maintain safe conditions for driving.

Malfunctioning item	Control contents during malfunction
Manifold absolute pressure sensor	<ol style="list-style-type: none"> 1. Uses the throttle position sensor signal and engine speed signal (crank angle sensor signal) to take reading of the basic injector drive time and basic ignition timing from the pre-set mapping. 2. Fixes the idle speed control servo in the appointed position so idle control is not performed.
Intake air temperature sensor	Controls as if the intake air temperature is 25° C.
Throttle position sensor	No increase in fuel injection amount during acceleration due to the throttle position sensor signal.
Engine coolant temperature sensor	Controls as if the engine coolant temperature is 80° C.
Camshaft position sensor	Injectors fuel into the cylinders in the order 1-3-4-2 with irregular timing. (After the ignition switch is turned to the "ON" position, the No. 1 cylinder top dead center is not detected at all)
Oxygen sensor (front)	Air-fuel ratio feedback control (closed loop control) is not performed.
Oxygen sensor (rear)	Performs the feedback control (closed loop control) of the air-fuel ratio by using only the signal of the oxygen (front) installed on the front of the catalytic converter.
Detonation sensor	Fixes the ignition timing as that for regular gasoline.
Ignition coil (incorporating power transistor)	Cuts off the fuel supply to cylinders with an abnormal ignition.
Alternator FR terminal	Does not control the output of the alternator according to an electrical load. (works as a normal alternator)
Misfiring	If the detected misfiring causes damage to the catalyst, the misfiring cylinder will be shut down.

INSPECTION CHART FOR DIAGNOSIS CODE

M1131151002006

Code No.	Diagnosis item	Reference page
P0105	Manifold absolute pressure sensor system	P.13A-18
P0110	Intake air temperature sensor system	P.13A-33
P0115	Engine coolant temperature sensor system	P.13A-43
P0120	Throttle position sensor system	P.13A-54
P0125*	Feedback system monitor	P.13A-68
P0130	Oxygen sensor (front) system <sensor 1>	P.13A-74
P0135	Oxygen sensor (front) heater system <sensor 1>	P.13A-84
P0136	Oxygen sensor (rear) system <sensor 2>	P.13A-91
P0141	Oxygen sensor (rear) heater system <sensor 2>	P.13A-102
P0170	Abnormal fuel system	P.13A-110
P0201	No.1 Injector system	P.13A-115
P0202	No.2 Injector system	P.13A-121
P0203	No.3 Injector system	P.13A-127
P0204	No.4 Injector system	P.13A-133
P0300	Random cylinder misfire detection system	P.13A-139
P0301*	No.1 cylinder misfire detection system	P.13A-144
P0302*	No.2 cylinder misfire detection system	P.13A-147
P0303*	No.3 cylinder misfire detection system	P.13A-150
P0304*	No.4 cylinder misfire detection system	P.13A-153
P0325	Detonation sensor system	P.13A-157
P0335	Crank angle sensor system	P.13A-161
P0340	Camshaft position sensor system	P.13A-175
P0403	EGR control solenoid valve system	P.13A-188
P0421	Warm up catalyst malfunction	P.13A-194
P0443	Purge control solenoid valve system	P.13A-195
P0500	Vehicle speed sensor system <M/T>	P.13A-203
P0505	Idle speed control system	P.13A-206
P0513	Immobilizer system	P.13A-213
P0551*	Power steering fluid pressure switch system	P.13A-216
P0622	Alternator FR terminal system	P.13A-224
P1603*	Battery back-up line system	P.13A-230

NOTE:

- Do not replace the engine-ECU <M/T> or engine-A/T-ECU <A/T> until a through terminal check reveals there are no short/open circuit.
- Check that the engine-ECU <M/T> or engine-A/T-ECU <A/T> earth circuit is normal before checking for the cause of the problem.
- After the engine-ECU <M/T> or engine-A/T-ECU <A/T> has detected a malfunction, a diagnosis code is recorded the next time the engine is started and the same malfunction is re-detected. However, for items marked with "***", the diagnosis code is recorded on the first detection of the malfunction.
- Sensor 1 indicates the sensor mounted at a position closest to the engine, and sensor 2 indicates the sensor mounted at the position second closest to the engine.

INSPECTION PROCEDURE FOR
DIAGNOSIS CODES

Code No. P0105: Manifold absolute Pressure Sensor System

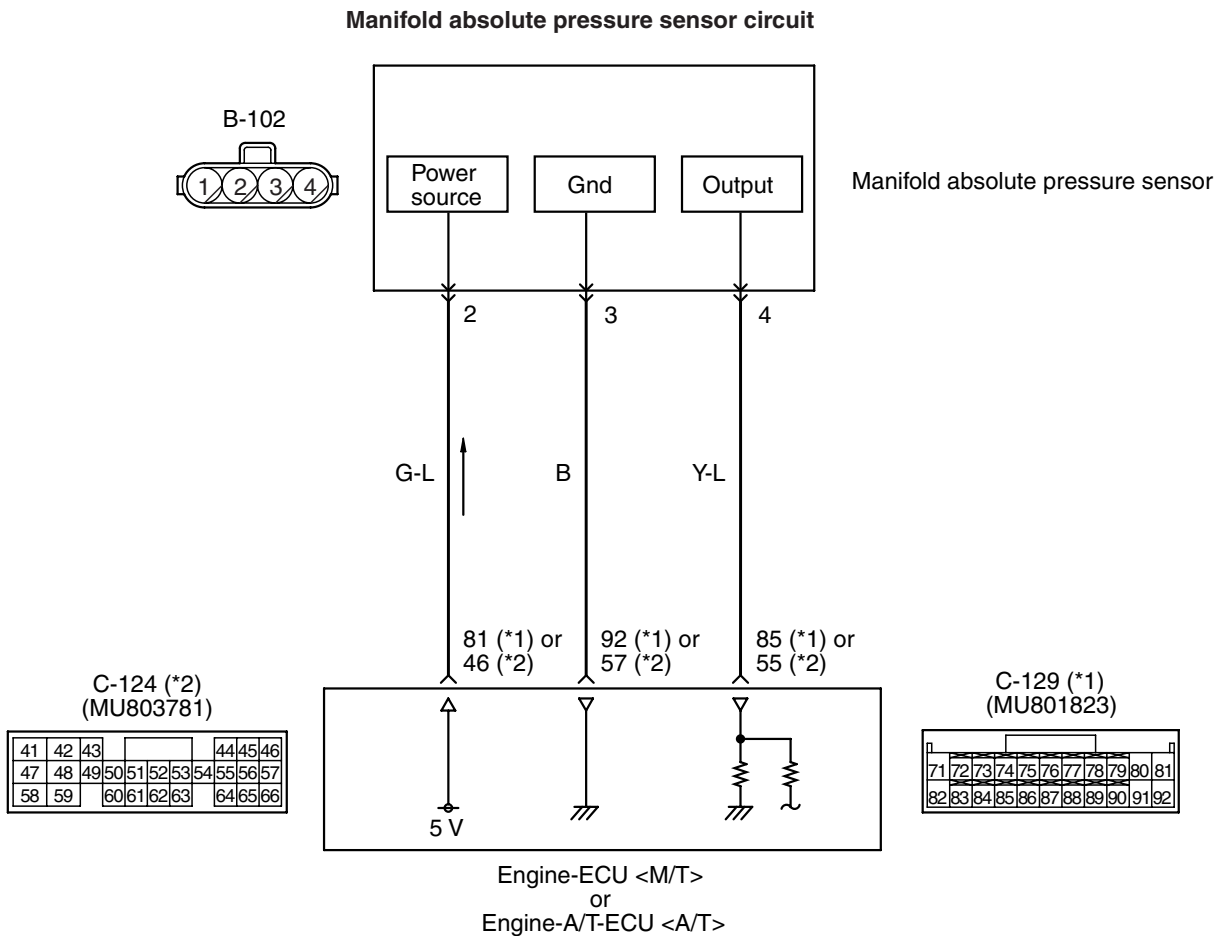

NOTE
*1: M/T
*2: A/T

Wire colour code
B: Black LG: Light green G: Green L: Blue W: White Y: Yellow SB: Sky blue BR: Brown O: Orange GR: Gray
R: Red P: Pink V: Violet

OPERATION

- A power voltage of 5 V is applied to the manifold absolute pressure sensor power terminal (terminal No. 2) from the engine-ECU (terminal No. 81) <M/T> or engine-A/T-ECU (terminal No. 46) <A/T> and earthed to the engine-ECU (terminal No. 85) <M/T> or engine-A/T-ECU (terminal No. 55) <A/T> from the manifold absolute pressure sensor (terminal No. 4).
- The sensor signal is inputted to the engine-ECU (terminal No. 92) <M/T> or engine-A/T-ECU (terminal No. 57) <A/T> from the manifold absolute pressure sensor output terminal (terminal No. 3).

FUNCTION

- The manifold absolute pressure sensor converts the manifold absolute pressure into a voltage signal and inputs the signal to the engine-ECU<M/T> or engine-A/T-ECU <A/T>.
- In response to the signal, the engine-ECU<M/T> or engine-A/T-ECU <A/T> corrects the fuel injection amount, etc.

TROUBLE JUDGMENT

Check Condition

- Ignition switch: ON

Judgment Criteria

- The output voltage is 4.5 V or more (Manifold absolute pressure of above 115 kPa or equivalent) for 2 seconds.

Check Conditions

- The output voltage of the throttle position sensor is 1.25 V or more.
- The vehicle is stationary.

Judgment Criteria

- The sensor output voltage is 0.2 V or less (Manifold absolute pressure of below 4.9 kPa equivalent) for 2 seconds.

PROBABLE CAUSE

- Failed Manifold absolute pressure sensor
- Open/short circuit in Manifold absolute pressure sensor circuit or loose connector contact
- Failed engine-ECU <M/T>
- Failed engine-A/T-ECU <A/T>

DIAGNOSIS PROCEDURE

STEP 1. M.U.T.-II/III data list

- Refer to data list reference table [P.13A-376](#).
 - Item 32: Manifold absolute pressure sensor

Q: Is the check result normal?

YES : Intermittent malfunction (Refer to GROUP 00 –How to Use Troubleshooting/Inspection Service Points [P.00-5](#)).

NO : Go to Step 2 .

STEP 2. Connector check: B-102 Manifold absolute pressure sensor connector

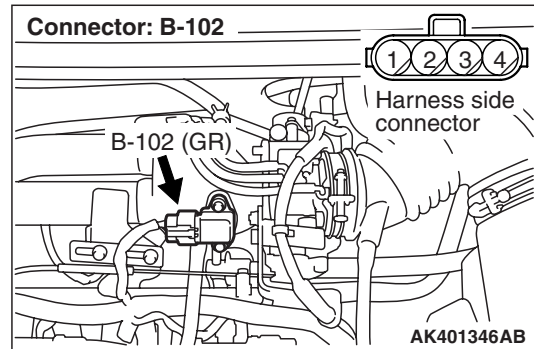

Q: Is the check result normal?

YES : Go to Step 3 .

NO : Repair or replace.

STEP 3. Perform voltage measurement at B-102 Manifold absolute pressure sensor connector.

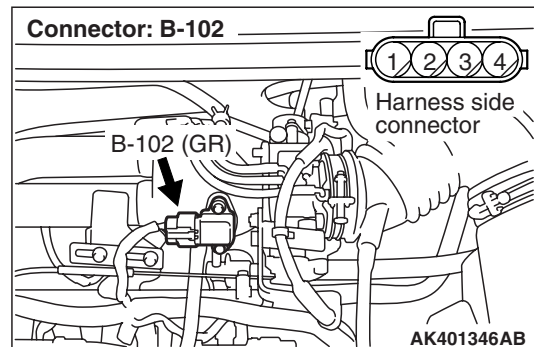

- Disconnect connector, and measure at harness side.
- Ignition switch: ON
- Voltage between terminal No. 2 and earth.

OK: 4.9 – 5.1 V

Q: Is the check result normal?

YES : Go to Step 9 .

NO : Go to Step 4 .

STEP 4. Perform voltage measurement at C-129 engine-ECU <M/T> connector or C-124 engine-A/T-ECU <A/T> connector.

Q: Is the check result normal?

YES : Go to Step 5 .

NO : Go to Step 6 .

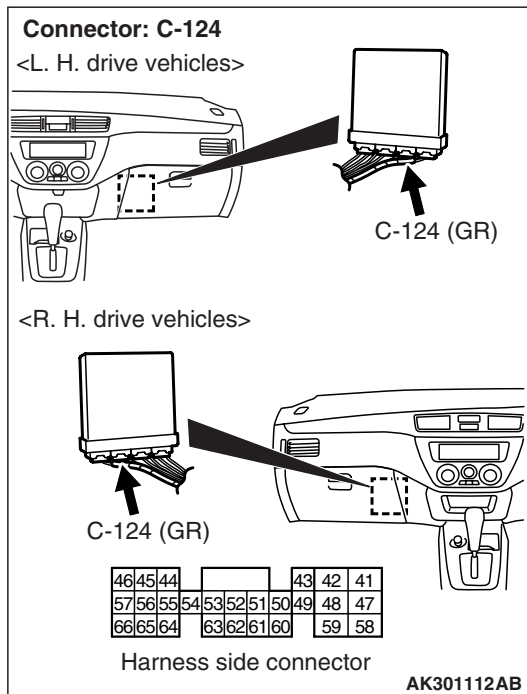
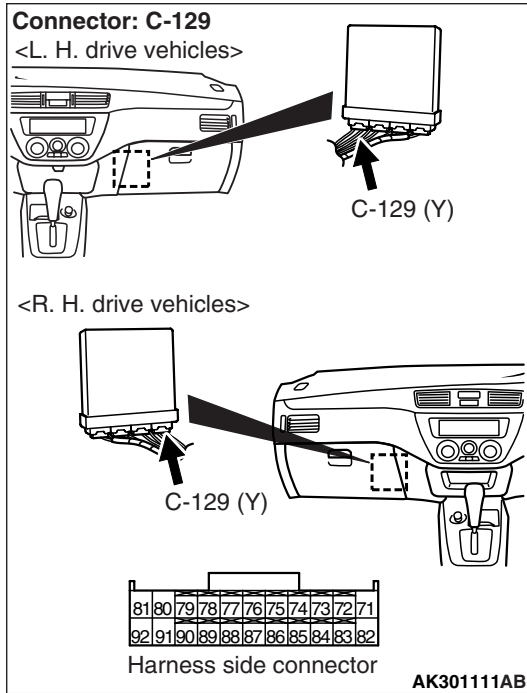

- Measure engine-ECU <M/T> or engine-A/T-ECU <A/T> terminal voltage.
- Ignition switch: ON
- Voltage between terminal No. 81 <M/T> or terminal No. 46 <A/T> and earth.

OK: 4.9 – 5.1 V

STEP 5. Connector check: C-129 engine-ECU <M/T> connector or C-124 engine-A/T-ECU <A/T> connector

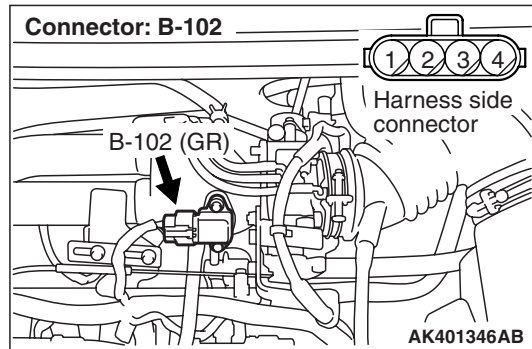
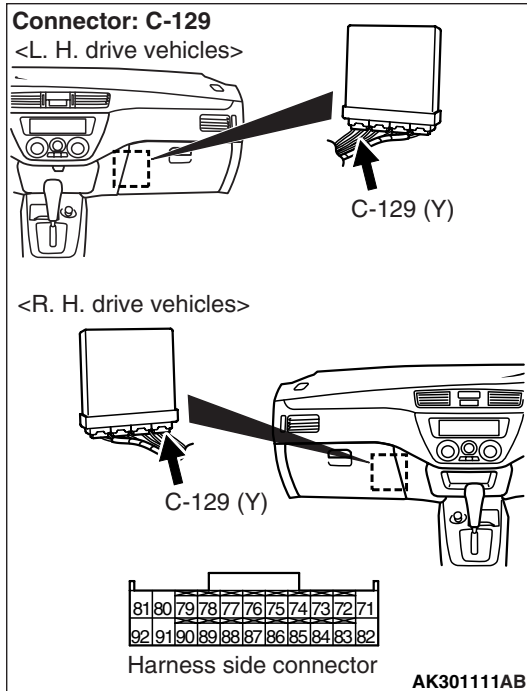

Q: Is the check result normal?

YES : Check and repair harness between B-102 (terminal No. 2) manifold absolute pressure sensor connector and C-129 (terminal No. 81) engine-ECU <M/T> connector or C-124 (terminal No. 46) engine-A/T-ECU <A/T> connector.

- Check power supply line for open circuit.

NO : Repair or replace.

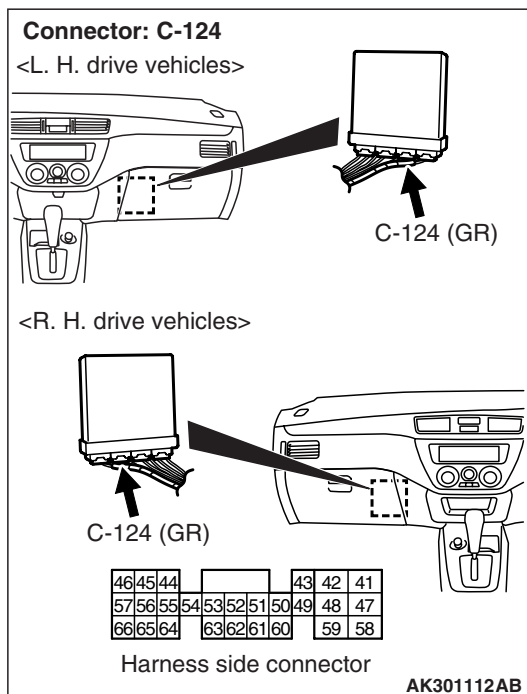

STEP 6. Connector check: C-129 engine-ECU <M/T> connector or C-124 engine-A/T-ECU <A/T> connector

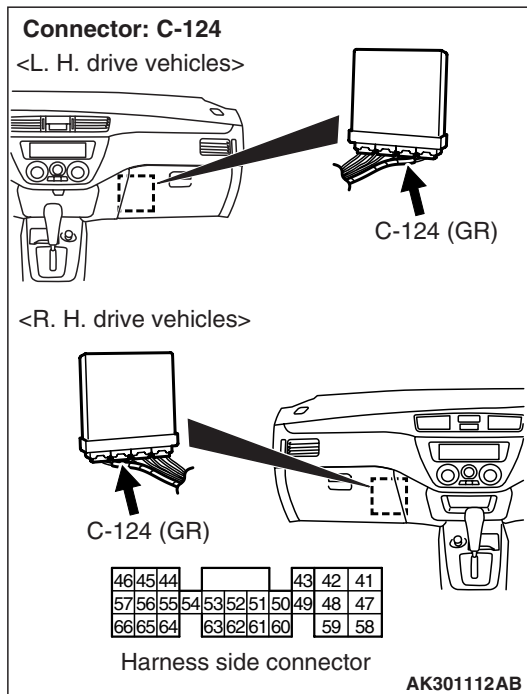
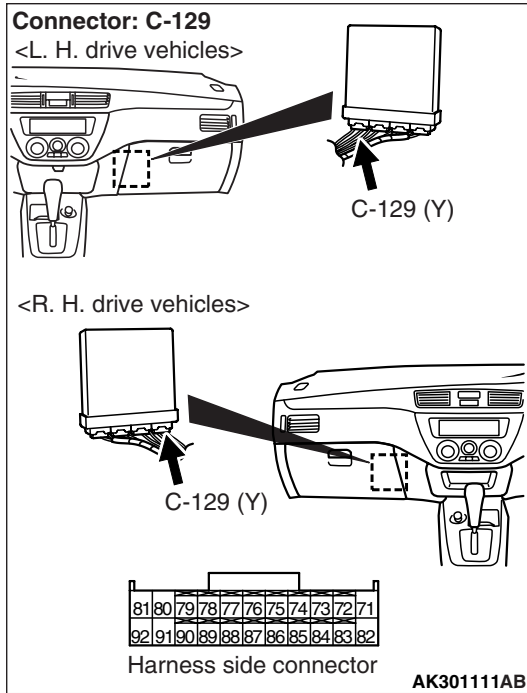

Q: Is the check result normal?

YES : Go to Step 7 .

NO : Repair or replace.

STEP 7. Check harness between B-102 (terminal No. 2) manifold absolute pressure sensor connector and C-129 (terminal No. 81) engine-ECU <M/T> connector or C-124 (terminal No. 46) engine-A/T-ECU <A/T> connector.

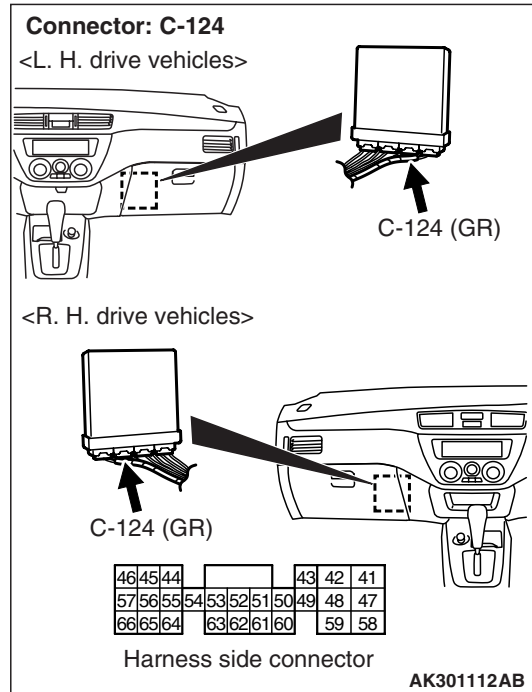
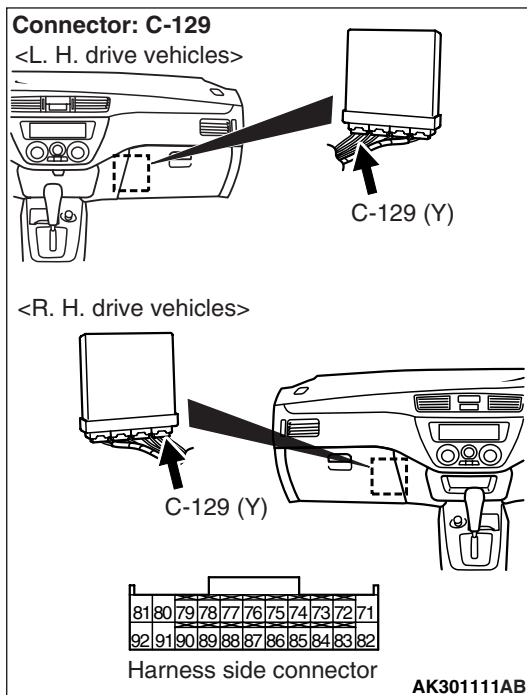
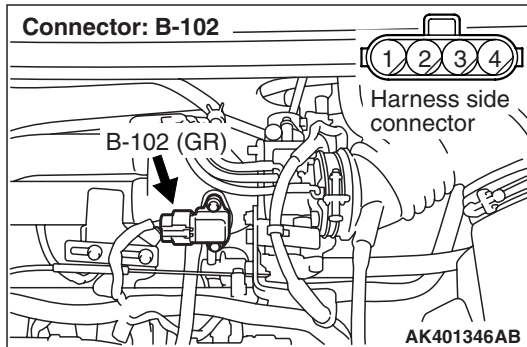

- Check power supply line for short circuit.

Q: Is the check result normal?

YES : Go to Step 8 .

NO : Repair.

STEP 8. M.U.T.-II/III data list

- Refer to data list reference table [P.13A-376](#).
 - Item No. 32: Manifold absolute pressure sensor

Q: Is the check result normal?

YES : Intermittent malfunction (Refer to GROUP 00 –How to Use Troubleshooting/Inspection Service Points [P.00-5](#)).

NO : Replace engine-ECU <M/T> or engine-A/T-ECU <A/T>.

STEP 9. Perform resistance measurement at B-102 manifold absolute pressure sensor connector.

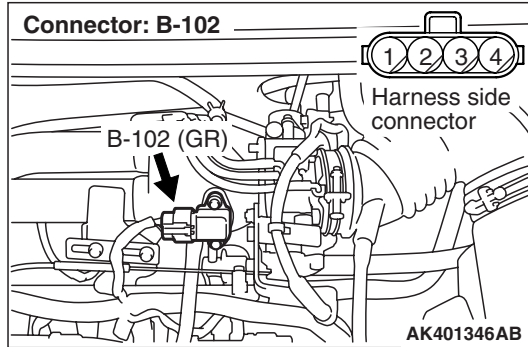

- Disconnect connector, and measure at harness side.
- Resistance between terminal No. 3 and earth.
OK: Continuity (2 Ω or less)

Q: Is the check result normal?
YES : Go to Step 12 .
NO : Go to Step 10 .

STEP 10. Connector check: C-129 engine-ECU <M/T> connector or C-124 engine-A/T-ECU <A/T> connector

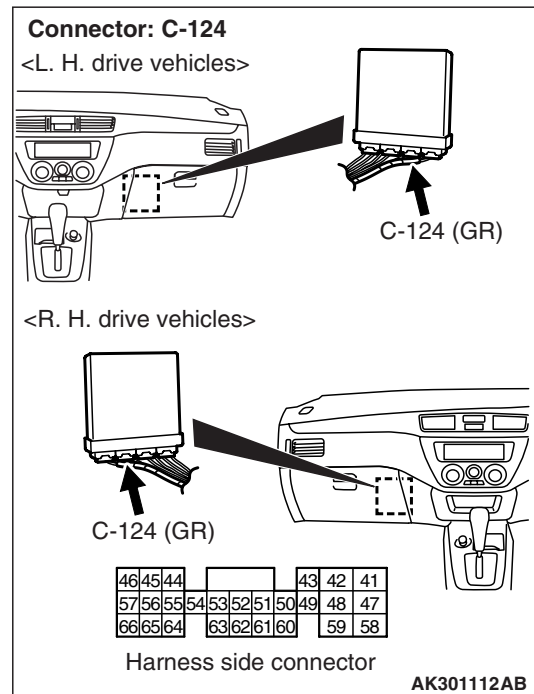
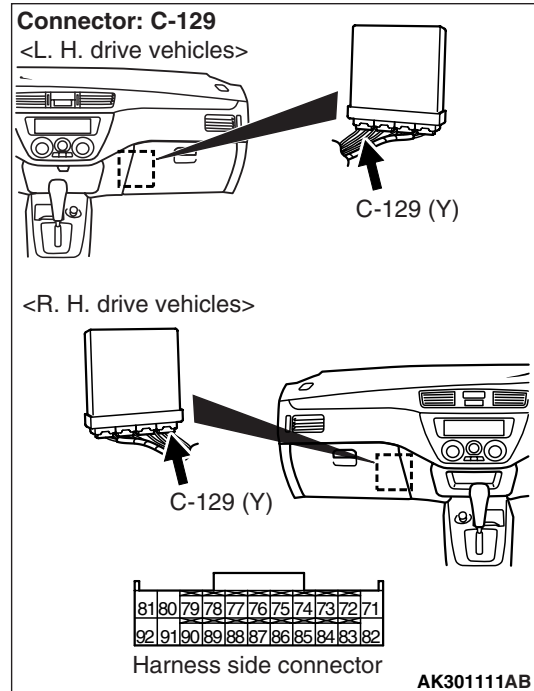

Q: Is the check result normal?
YES : Go to Step 11 .
NO : Repair or replace.

STEP 11. Check harness between B-102 (terminal No. 3) manifold absolute pressure sensor connector and C-129 (terminal No. 92) engine-ECU <M/T> connector or C-124 (terminal No. 57) engine-A/T-ECU <A/T> connector.

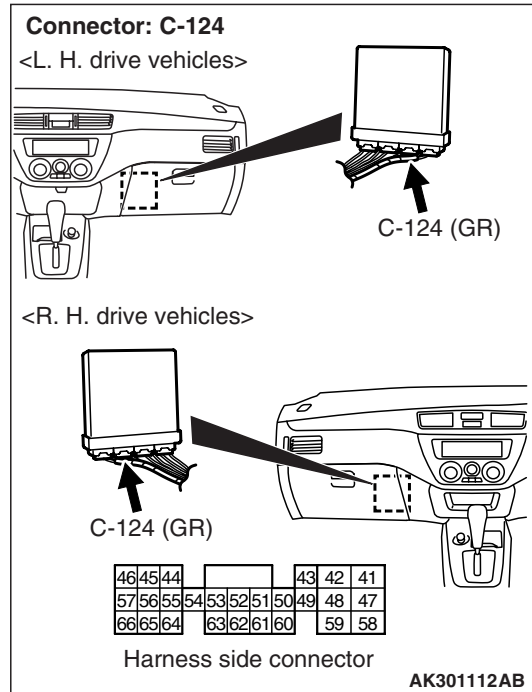
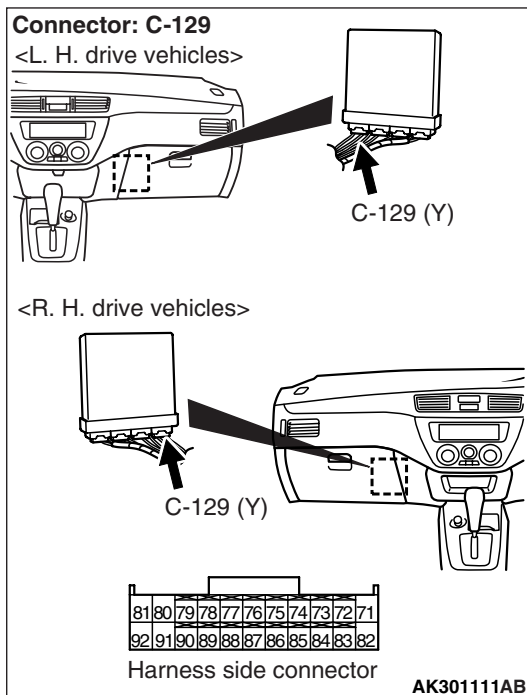
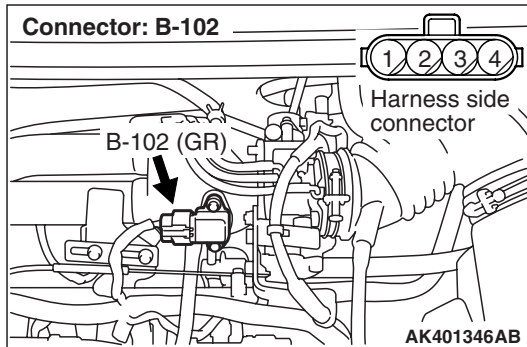

- Check earthing line for open circuit or damage.

Q: Is the check result normal?

YES : Go to Step 8 .

NO : Repair.

STEP 12. Perform voltage measurement at B-102 manifold absolute pressure sensor connector.

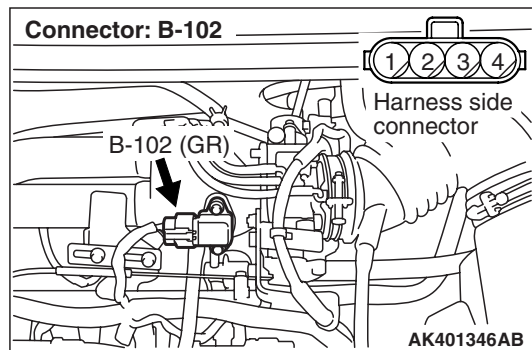

- Use special tool test harness (MB991348) to connect only terminal No. 2 and then measure at pick-up harness.
- Ignition switch: ON
- Voltage between terminal No. 2 and earth.

OK: 4.9 – 5.1 V

Q: Is the check result normal?

YES : Go to Step 14 .

NO : Go to Step 13 .

STEP 13. Connector check: C-129 engine-ECU <M/T> connector or C-124 engine-A/T-ECU <A/T> connector

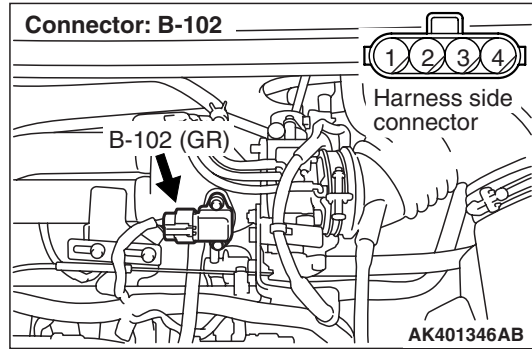
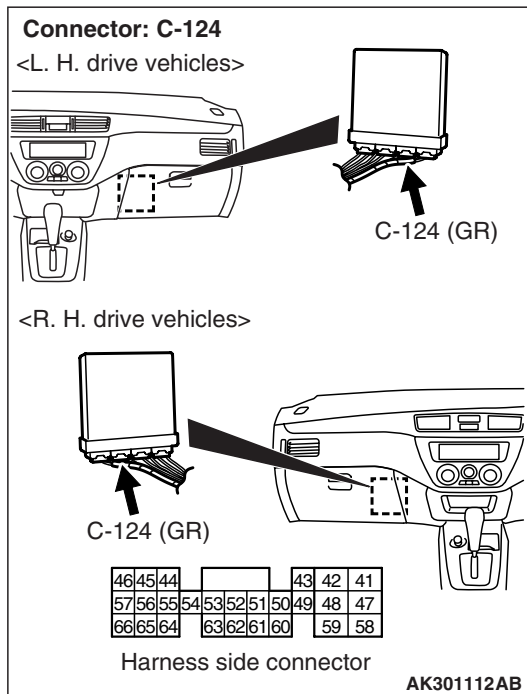
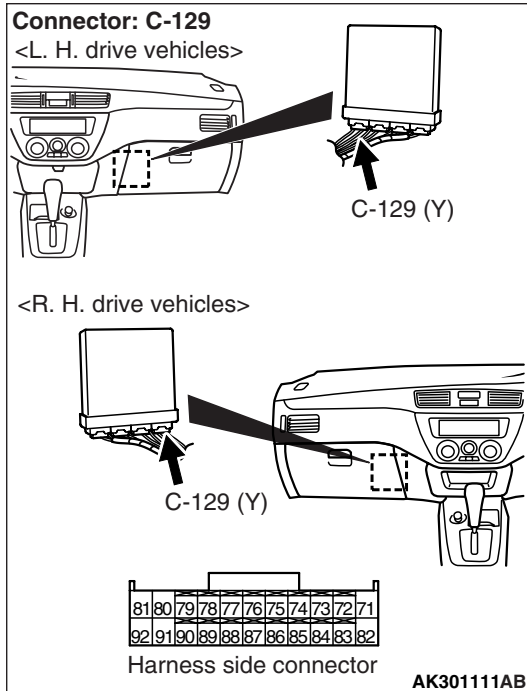

Q: Is the check result normal?

YES : Check and repair harness between B-102 (terminal No. 2) manifold absolute pressure sensor connector and C-129 (terminal No. 81) engine-ECU <M/T> connector or C-124 (terminal No. 46) engine-A/T-ECU <A/T> connector.

- Check power supply line for damage.

NO : Repair or replace.

STEP 14. Perform voltage measurement at B-102 manifold absolute pressure sensor connector.

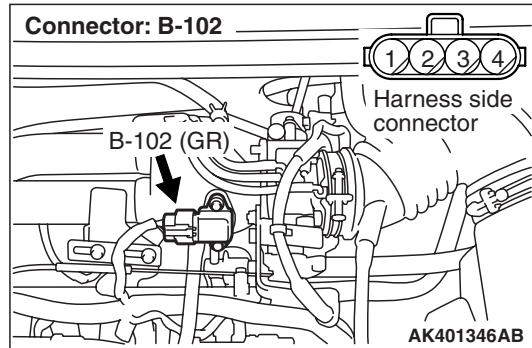

- Use special tool test harness (MB991348) to connect only terminal No. 3 and then measure at pick-up harness.
- Ignition switch: ON
- Voltage between terminal No. 3 and earth.

OK: 0.5 V or less

Q: Is the check result normal?

YES : Go to Step 16 .

NO : Go to Step 15 .

STEP 15. Connector check: C-129 engine-ECU <M/T> connector or C-124 engine-A/T-ECU <A/T> connector

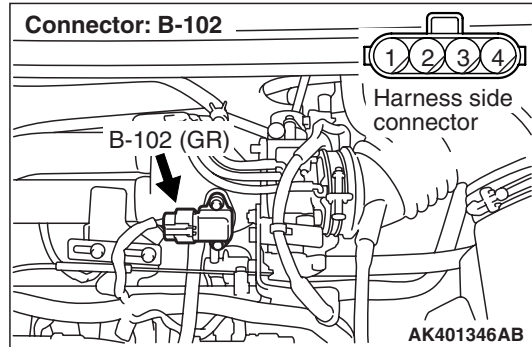
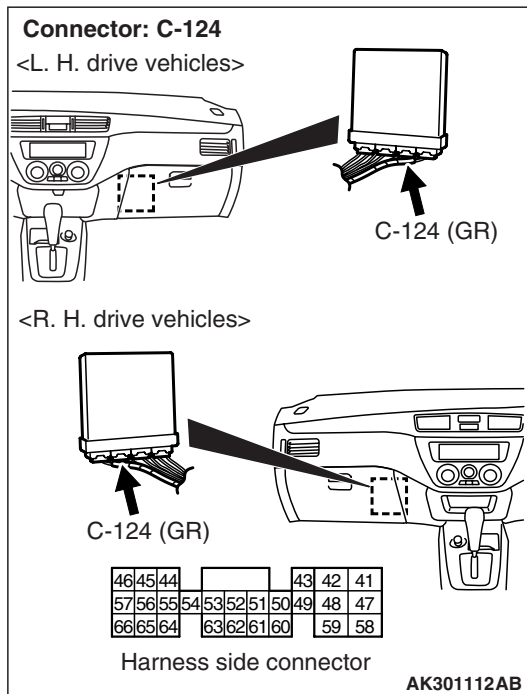
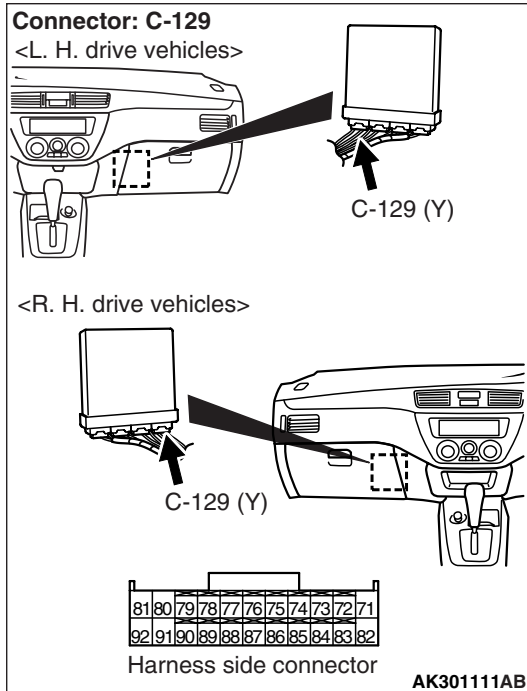

Q: Is the check result normal?

YES : Check and repair harness between B-102 (terminal No. 3) manifold absolute pressure sensor connector and C-129 (terminal No. 92) engine-ECU <M/T> connector or C-124 (terminal No. 57) engine-A/T-ECU <A/T> connector.

- Check earthing line for damage.

NO : Repair or replace.

STEP 16. Perform voltage measurement at B-102 manifold absolute pressure sensor connector.

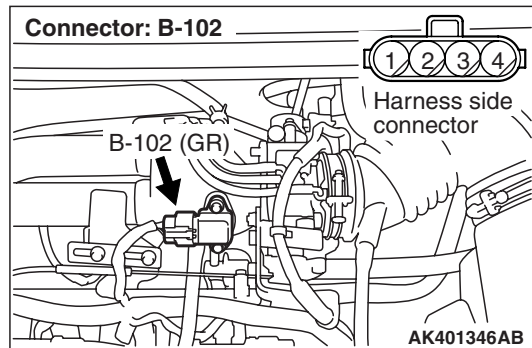

- Use special tool test harness (MB991348) to connect only terminal No. 4 and then measure at pick-up harness.
- Ignition switch: ON
- Voltage between terminal No. 4 and earth.

OK:

Altitude 0m: 3.8 – 4.2 V
Altitude 600m: 3.5 – 3.9 V
Altitude 1,200m: 3.3 – 3.7 V
Altitude 1,800m: 3.0 – 3.4 V

Q: Is the check result normal?

YES : Go to Step 19 .

NO : Go to Step 17 .

STEP 17. Connector check: C-129 engine-ECU <M/T> connector or C-124 engine-A/T-ECU <A/T> connector

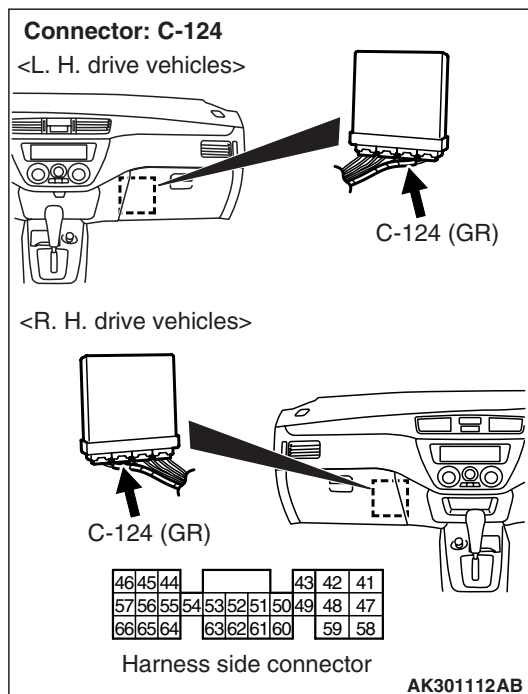
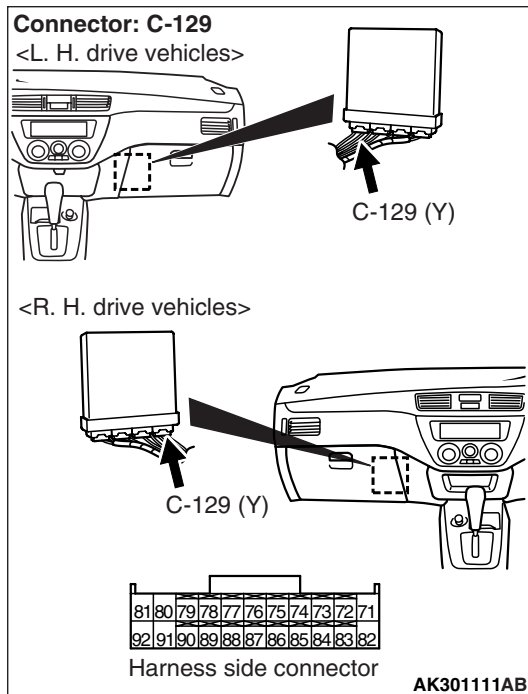

Q: Is the check result normal?

YES : Go to Step 18 .

NO : Repair or replace.

STEP 18. Check harness between B-102 (terminal No. 4) manifold absolute pressure sensor connector and C-129 (terminal No. 85) engine-ECU <M/T> connector or C-124 (terminal No. 55) engine-A/T-ECU <A/T> connector.

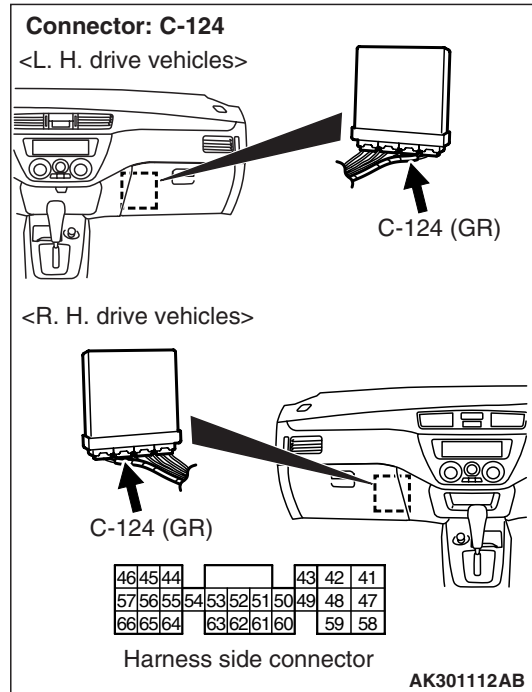
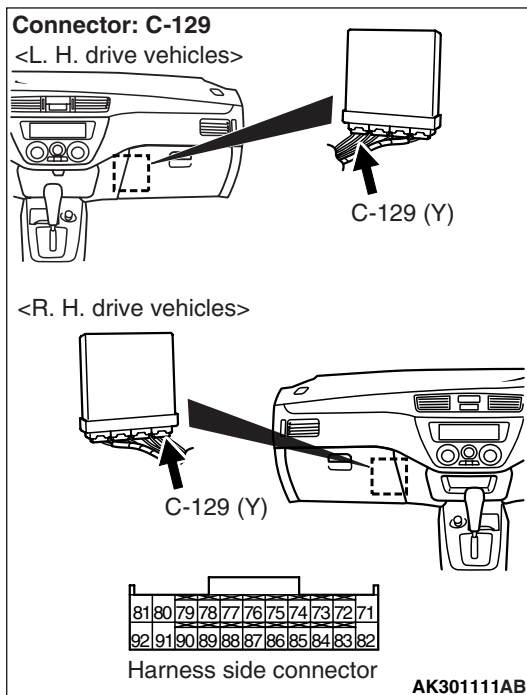
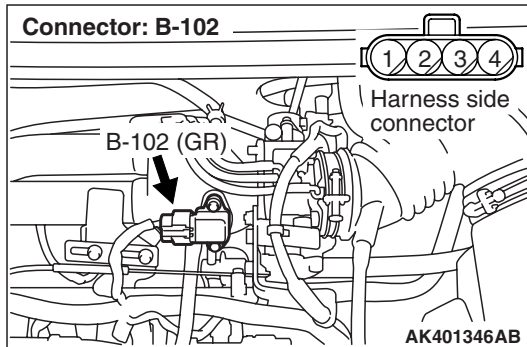

- Check output line for short circuit and damage.
- Q: Is the check result normal?**
YES : Replace manifold absolute pressure sensor.
NO : Repair.

STEP 19. Perform voltage measurement at C-129 engine-ECU <M/T> connector or C-124 engine-A/T-ECU <A/T> connector.

OK:
 Altitude 0m: 3.8 – 4.2 V
 Altitude 600m: 3.5 – 3.9 V
 Altitude 1,200m: 3.3 – 3.7 V
 Altitude 1,800m: 3.0 – 3.4 V

Q: Is the check result normal?
YES : Go to Step 21 .
NO : Go to Step 20 .

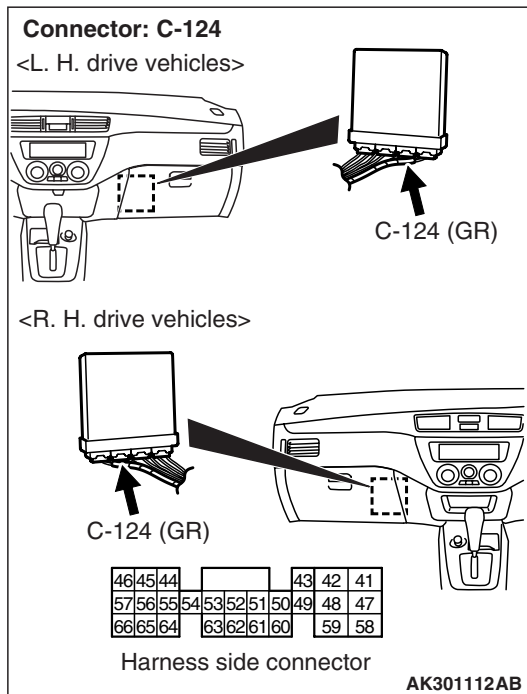
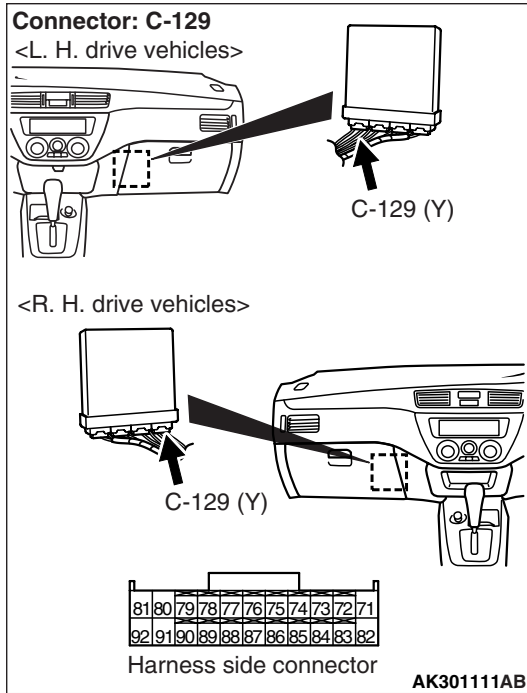

- Measure engine-ECU <M/T> or engine-A/T-ECU <A/T> terminal voltage.
- Ignition switch: ON
- Voltage between terminal No. 85 <M/T> or terminal No. 55 <A/T> and earth.

STEP 20. Connector check: C-129 engine-ECU <M/T> connector or C-124 engine-A/T-ECU <A/T> connector

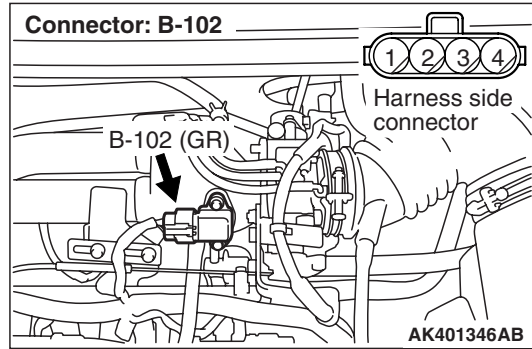
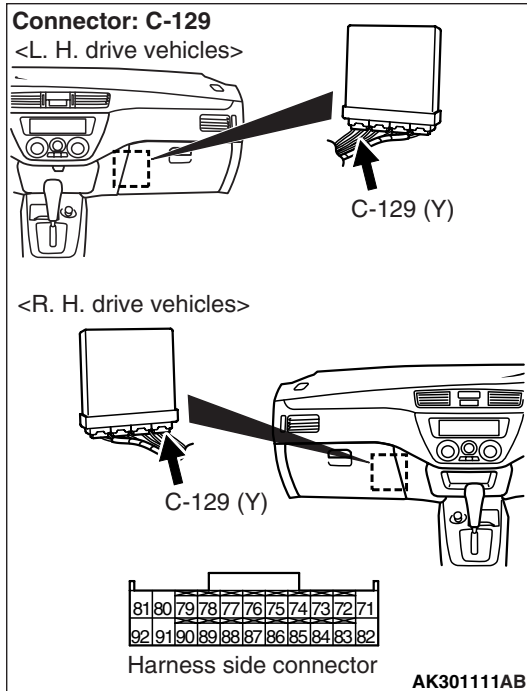

Q: Is the check result normal?

YES : Check and repair harness between B-102 (terminal No. 4) manifold absolute pressure sensor connector and C-129 (terminal No. 85) engine-ECU <M/T> connector or C-124 (terminal No. 55) engine-A/T-ECU <A/T> connector.

- Check output line for open circuit and damage.

NO : Repair or replace.

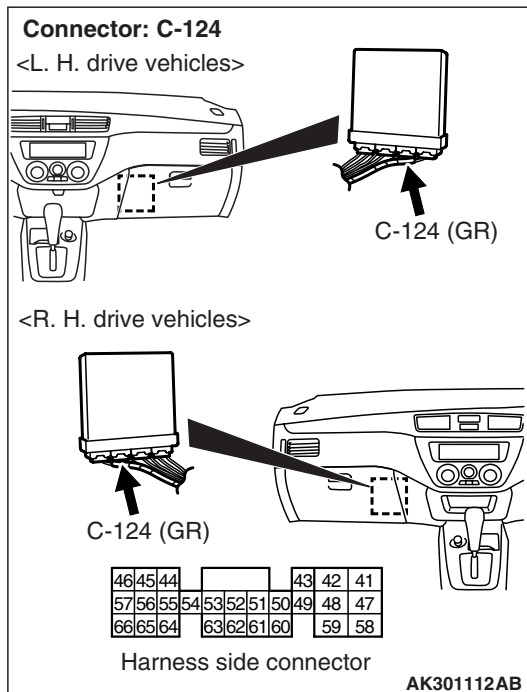

STEP 21. Connector check: C-129 engine-ECU <M/T> connector or C-124 engine-A/T-ECU <A/T> connector

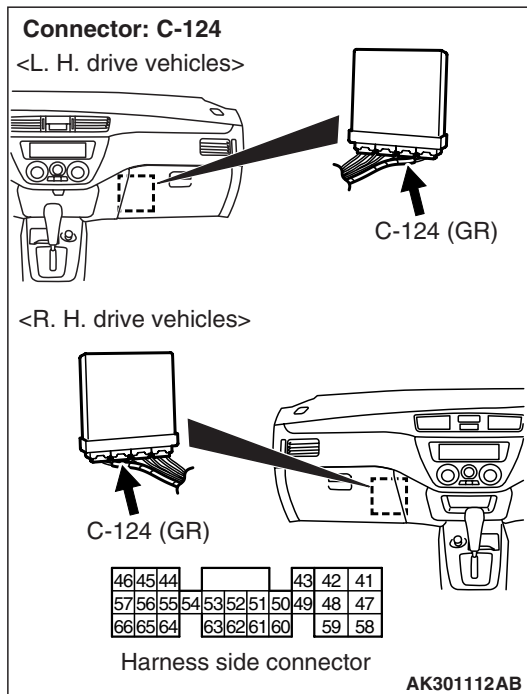
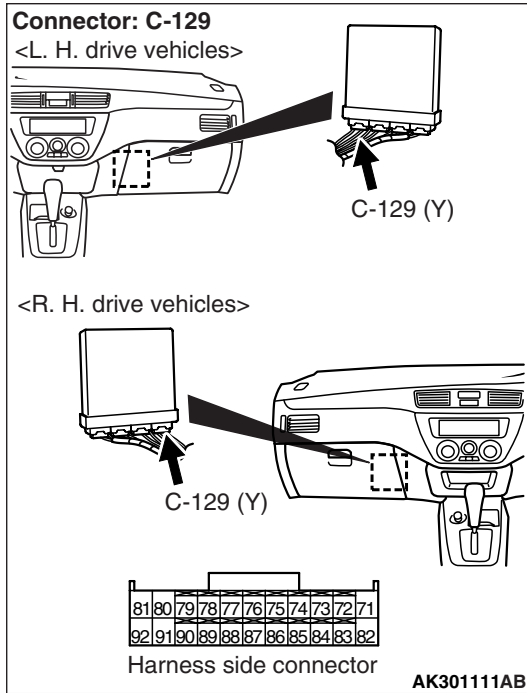

Q: Is the check result normal?

YES : Go to Step 8 .

NO : Repair or replace.

Code No. P0110: Intake Air Temperature Sensor System

Intake air temperature sensor circuit

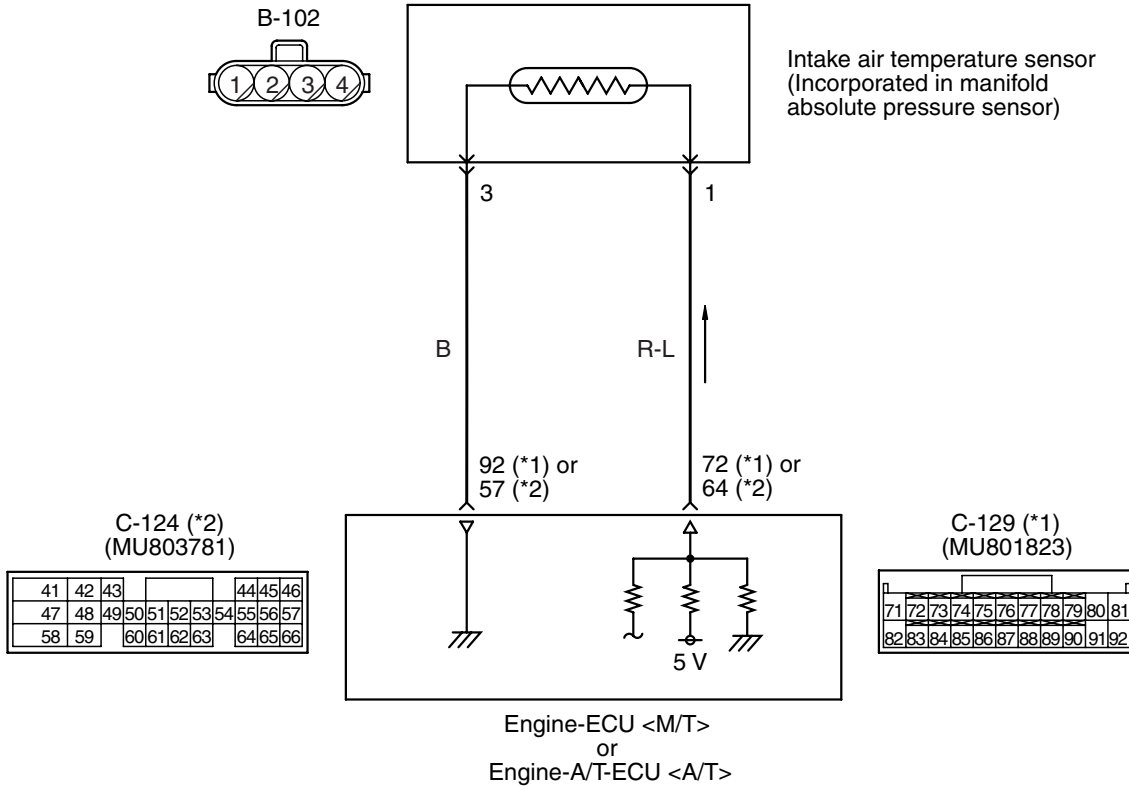

AK401347AB

OPERATION

- A power voltage of 5 V is applied to the intake air temperature sensor output terminal (terminal No. 1) of the Manifold absolute pressure sensor connector from the engine-ECU (terminal No. 72) <M/T> or engine-A/T-ECU (terminal No. 64) <A/T>.
- The power voltage is earthed to the engine-ECU (terminal No. 92) <M/T> or engine-A/T-ECU (terminal No. 57) <A/T> from the Manifold absolute pressure sensor (terminal No. 3).

FUNCTION

- The intake air temperature sensor converts the intake air temperature into a voltage and inputs the voltage signal to the engine-ECU <M/T> or engine-A/T-ECU <A/T>.

- In response to the signal, the engine-ECU <M/T> or engine-A/T-ECU <A/T> corrects the fuel injection amount, etc.
- The intake air temperature sensor is a kind of resistor, which has characteristics to reduce its resistance as the intake air temperature rises. Therefore, the sensor output voltage varies with the intake air temperature, and becomes lower as the intake air temperature rises.

TROUBLE JUDGMENT

Check Condition

- 2 seconds later after the ignition switch has been in "ON" position or the engine has started up.

Judgment Criteria

- The sensor output voltage is 4.6 V or more (intake air temperature of below -45°C or equivalent) for 2 seconds.

or

- The sensor output voltage is 0.2 V or less (intake air temperature of above 125°C or equivalent) for 2 seconds.

PROBABLE CAUSE

- Failed intake air temperature sensor
- Open/short circuit in intake air temperature sensor circuit or loose connector contact
- Failed engine-ECU <M/T>
- Failed engine-A/T-ECU <A/T>

DIAGNOSIS PROCEDURE**STEP 1. M.U.T.-II/III data list**

- Refer to data list reference table [P.13A-376](#).
 - Item 13: Intake air temperature sensor

OK: At ambient temperature (atmospheric temperature) or equivalent.

Q: Is the check result normal?

YES : Intermittent malfunction (Refer to GROUP 00 –How to Use Troubleshooting/Inspection Service Points [P.00-5](#)).

NO : Go to Step 2 .

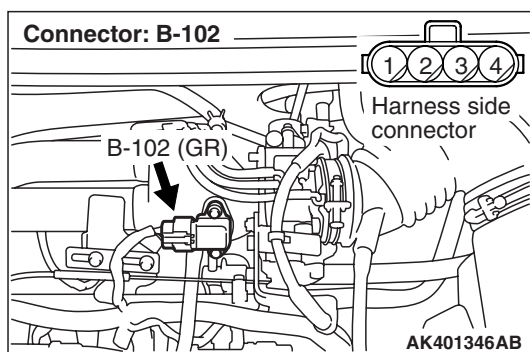
STEP 2. Connector check: B-102 manifold absolute pressure sensor connector**Q: Is the check result normal?**

YES : Go to Step 3 .

NO : Repair or replace.

STEP 3. Check intake air temperature sensor itself.

- Check intake air temperature sensor itself (Refer to [P.13A-404](#)).

Q: Is the check result normal?

YES : Go to Step 4 .

NO : Replace manifold absolute pressure sensor.

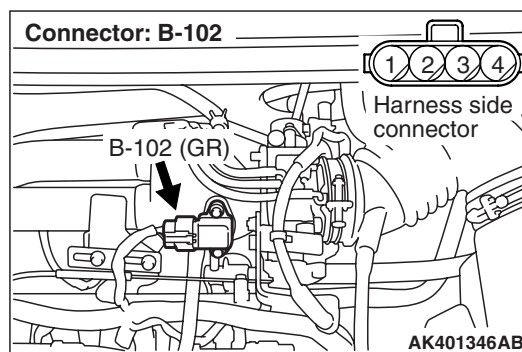
STEP 4. Perform resistance measurement at B-102 manifold absolute pressure sensor connector.

- Disconnect connector, and measure at harness side.

- Resistance between terminal No. 3 and earth.

OK: Continuity ($2\ \Omega$ or less)

Q: Is the check result normal?

YES : Go to Step 8 .

NO : Go to Step 5 .

**STEP 5. Connector check: C-129 engine-ECU
<M/T> connector or C-124 engine-A/T-ECU <A/T>
connector**

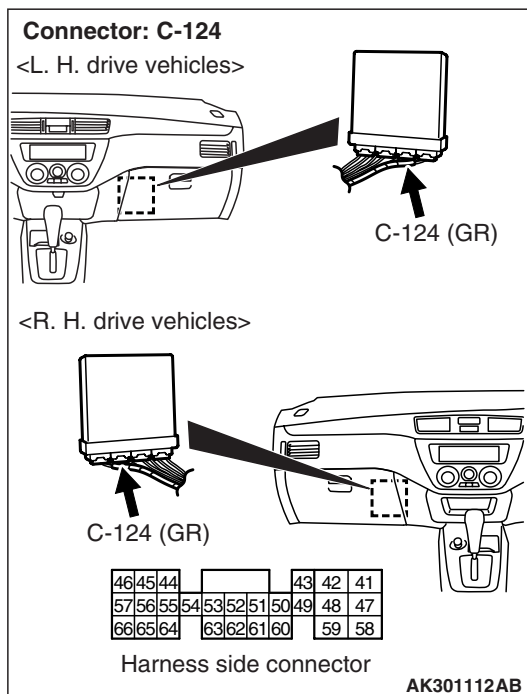
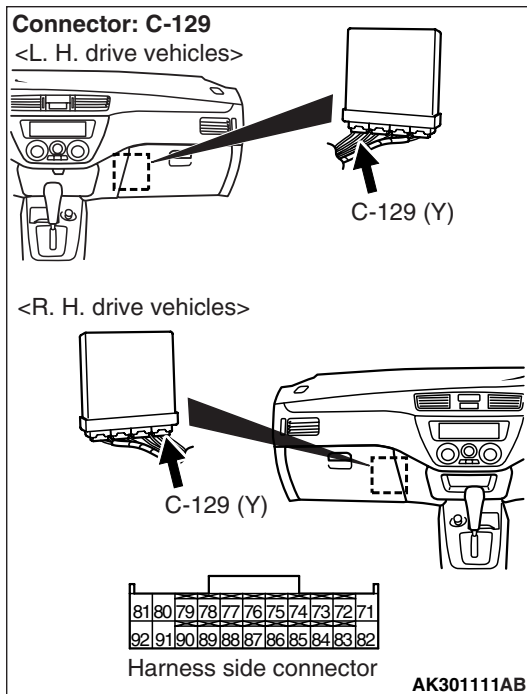

Q: Is the check result normal?

YES : Go to Step 6 .

NO : Repair or replace.

STEP 6. Check harness between B-102 (terminal No. 3) manifold absolute pressure sensor connector and C-129 (terminal No. 92) engine-ECU <M/T> connector or C-124 (terminal No. 57) engine-A/T-ECU <A/T> connector.

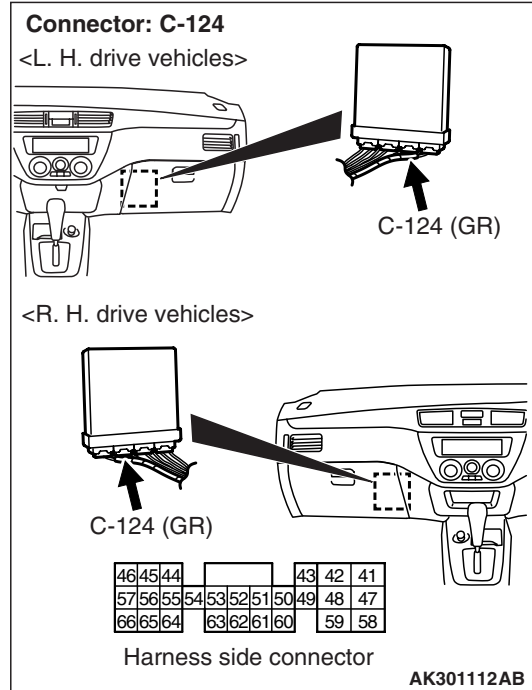
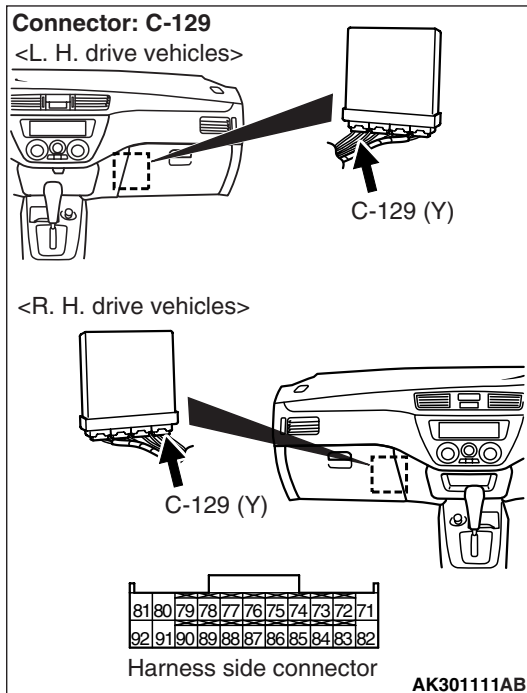
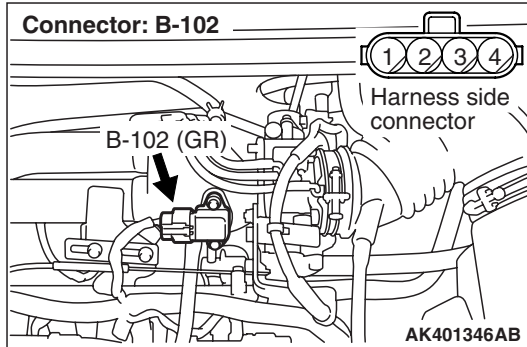

- Check earthing line for open circuit and damage.

Q: Is the check result normal?

YES : Go to Step 7 .

NO : Repair.

STEP 7. M.U.T.-II/III data list

- Refer to data list reference table [P.13A-376](#).

a. Item 13: Intake air temperature sensor

OK: At ambient temperature or equivalent.

Q: Is the check result normal?

YES : Intermittent malfunction (Refer to GROUP 00 –How to Use Troubleshooting/Inspection Service Points [P.00-5](#)).

NO : Replace engine-ECU <M/T> or engine-A/T-ECU <A/T>.

STEP 8. Perform voltage measurement at B-102 manifold absolute pressure sensor connector.

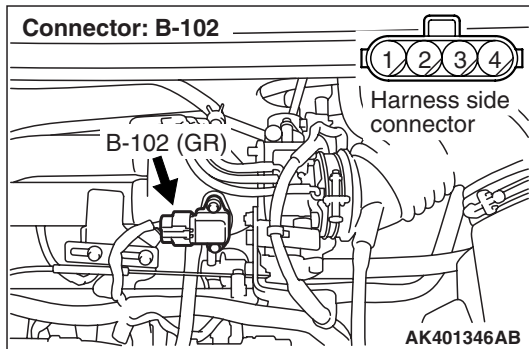

- Disconnect connector, and measure at harness side.
- Ignition switch: ON
- Voltage between terminal No. 1 and earth.
OK: 4.5 – 4.9 V

Q: Is the check result normal?
YES : Go to Step 13 .
NO : Go to Step 9 .

STEP 9. Perform voltage measurement at C-129 engine-ECU <M/T> connector or C-124 engine-A/T-ECU <A/T> connector.

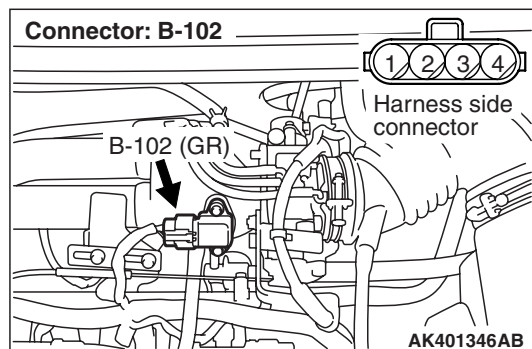
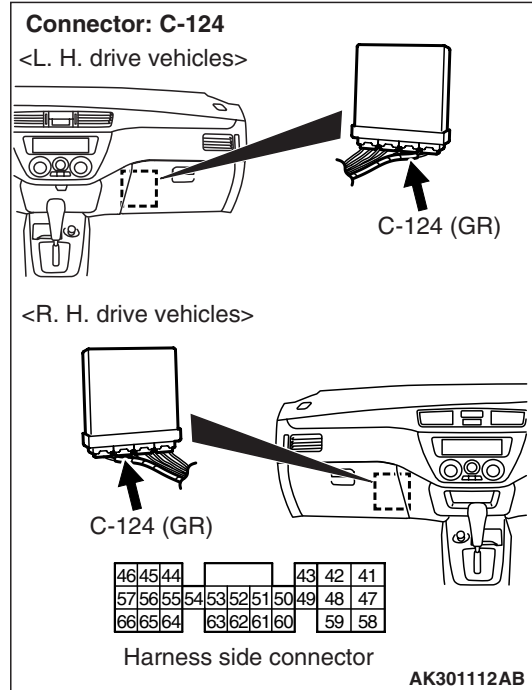
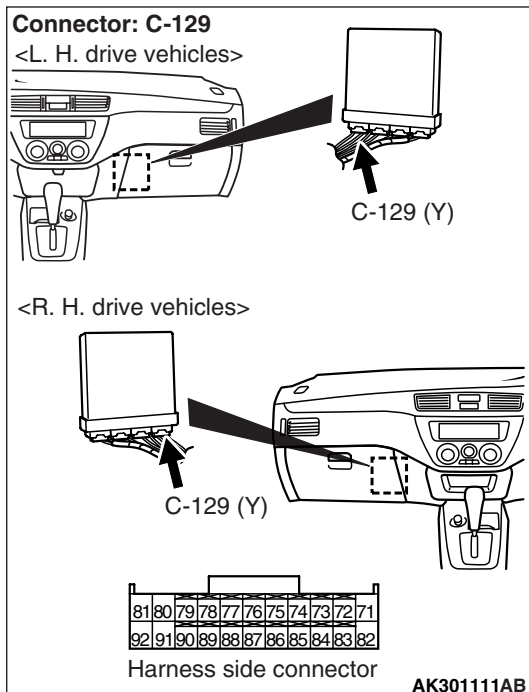

- Measure engine-ECU <M/T> or engine-A/T-ECU <A/T> terminal voltage.
- Disconnect B-102 manifold absolute pressure sensor connector.
- Ignition switch: ON
- Voltage between terminal No. 72 <M/T> or terminal No. 64 <A/T> and earth.
OK: 4.5 – 4.9 V

Q: Is the check result normal?
YES : Go to Step 10 .
NO : Go to Step 11 .

STEP 10. Connector check: C-129 engine-ECU <M/T> connector or C-124 engine-A/T-ECU <A/T> connector

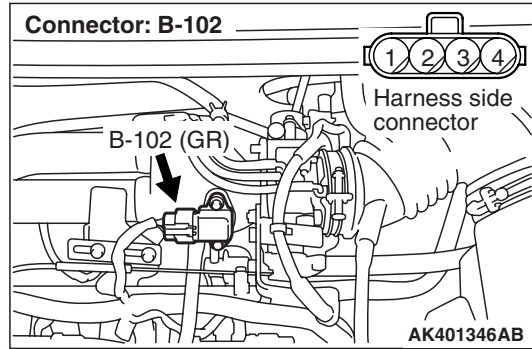
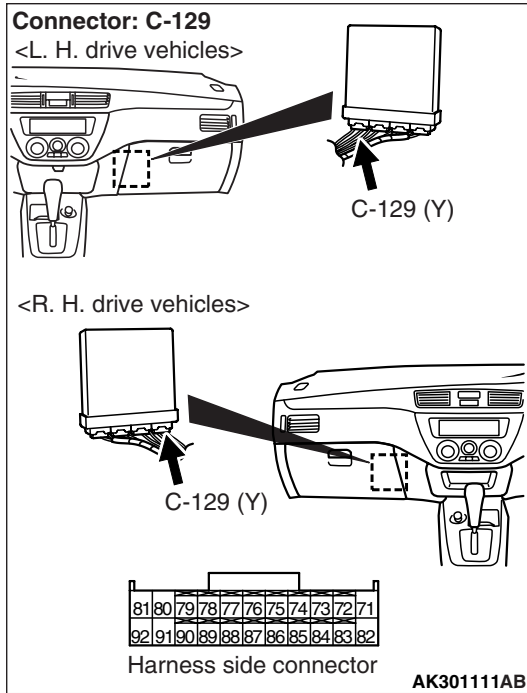

Q: Is the check result normal?

YES : Check and repair harness between B-102 (terminal No. 1) manifold absolute pressure sensor connector and C-129 (terminal No. 72) engine-ECU <M/T> connector or C-124 (terminal No. 64) engine-A/T-ECU <A/T> connector.

- Check output line for open circuit.

NO : Repair or replace.

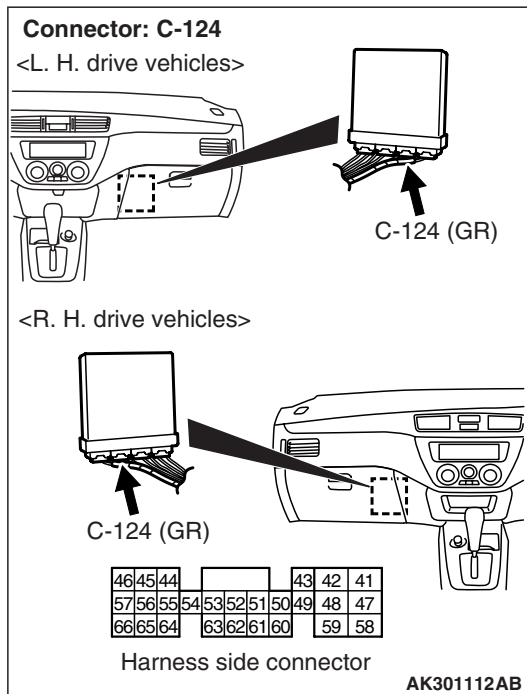

STEP 11. Connector check: C-129 engine-ECU <M/T> connector or C-124 engine-A/T-ECU <A/T> connector

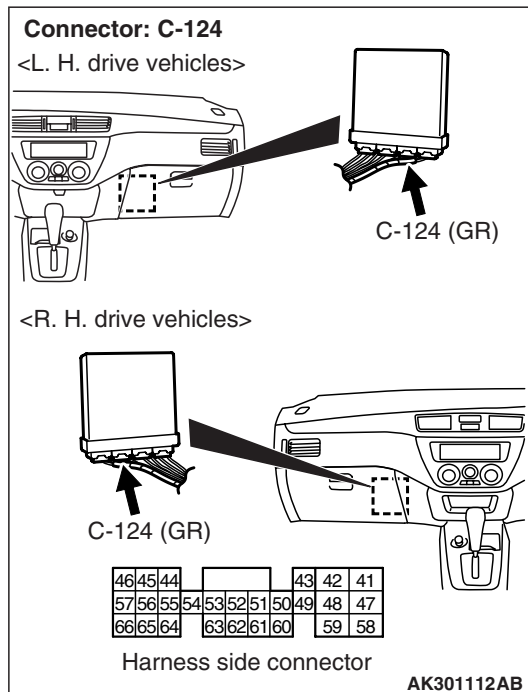
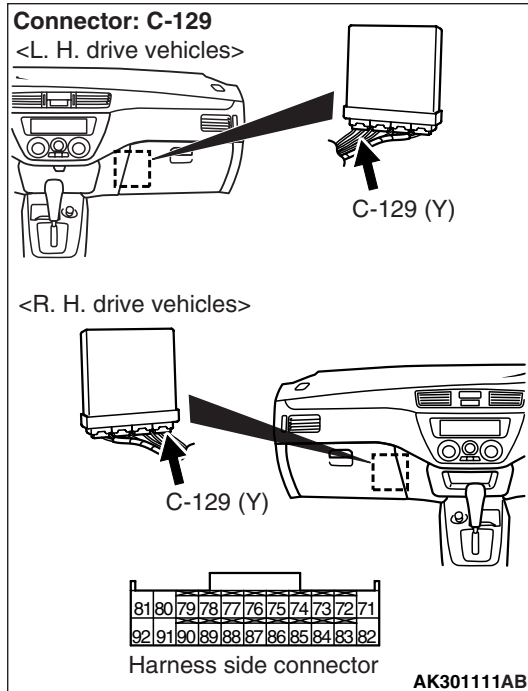

STEP 12. Check harness between B-102 (terminal No. 1) manifold absolute pressure sensor connector and C-129 (terminal No. 72) engine-ECU <M/T> connector or C-124 (terminal No. 64) engine-A/T-ECU <A/T> connector.

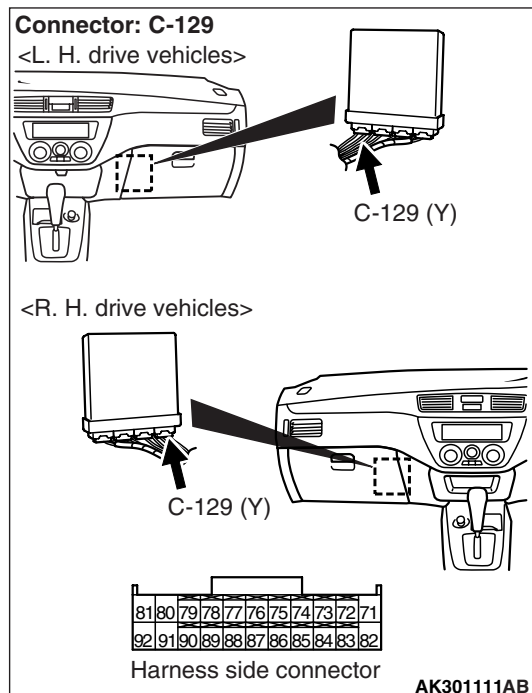
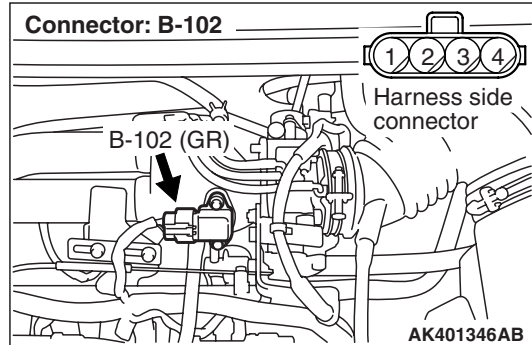

Q: Is the check result normal?
YES : Go to Step 12 .
NO : Repair or replace.

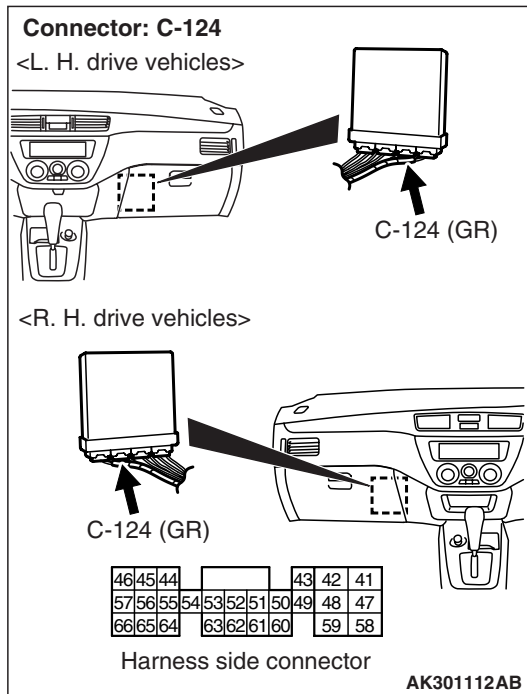

- Check output line for short circuit.

Q: Is the check result normal?

YES : Go to Step 7 .

NO : Repair.

STEP 13. Perform voltage measurement at B-102 manifold absolute pressure sensor connector.

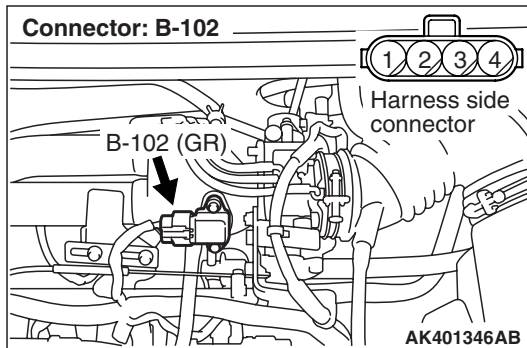

- Use special tool test harness (MB991348) to connect only terminal No. 1 and No. 3, and then measure at pick-up harness.
- Ignition switch: ON
- Voltage between terminal No. 1 and earth.

OK:

Ambient temperature at - 20° C: 3.8 – 4.4 V

Ambient temperature at 0° C: 3.2 – 3.8 V

Ambient temperature at 20° C: 2.3 – 2.9 V

Ambient temperature at 40° C: 1.5 – 2.1 V

Ambient temperature at 60° C: 0.8 – 1.4 V

Ambient temperature at 80° C: 0.4 – 1.0 V

Q: Is the check result normal?

YES : Go to Step 7 .

NO : Go to Step 14 .

STEP 14. Connector check: C-129 engine-ECU <M/T> connector or C-124 engine-A/T-ECU <A/T> connector

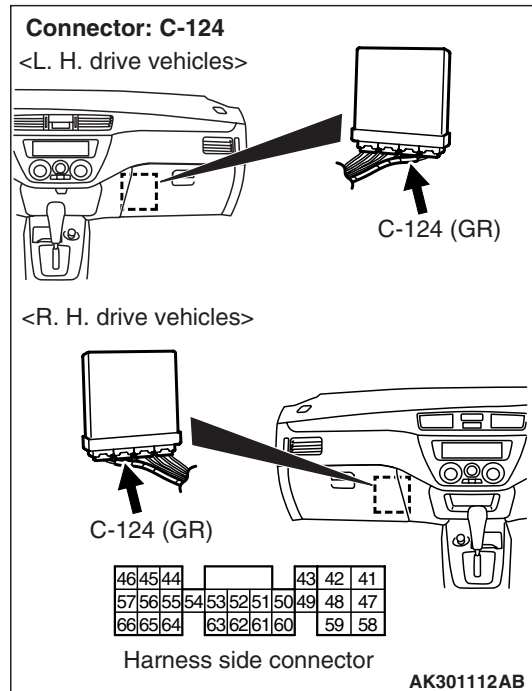
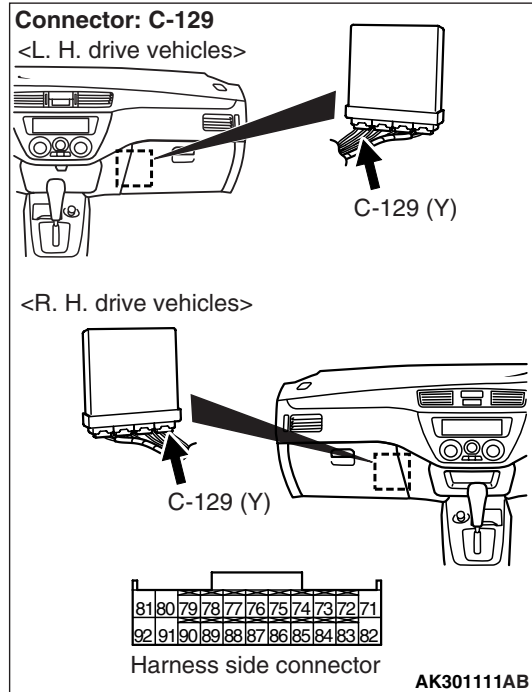

Q: Is the check result normal?

YES : Go to Step 15 .

NO : Repair or replace.

STEP 15. Check harness between B-102 (terminal No. 1) manifold absolute pressure sensor connector and C-129 (terminal No. 72) engine-ECU <M/T> connector or C-124 (terminal No. 64) engine-A/T-ECU <A/T> connector.

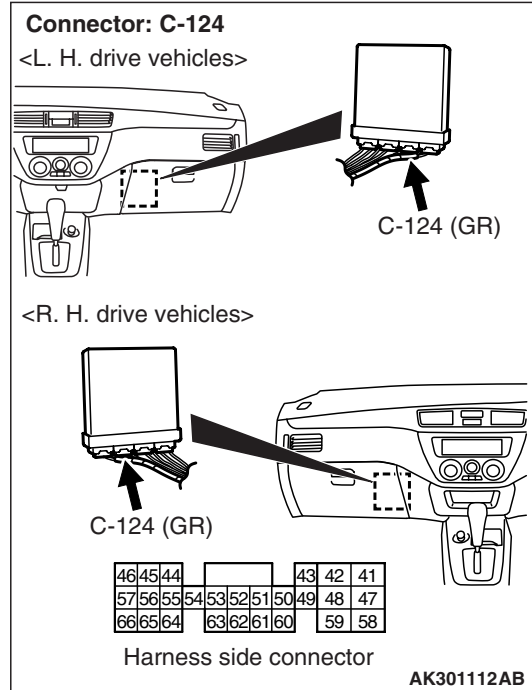
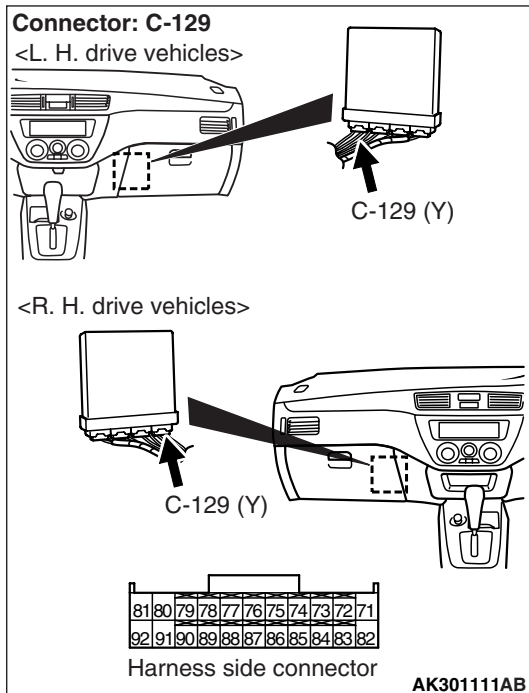
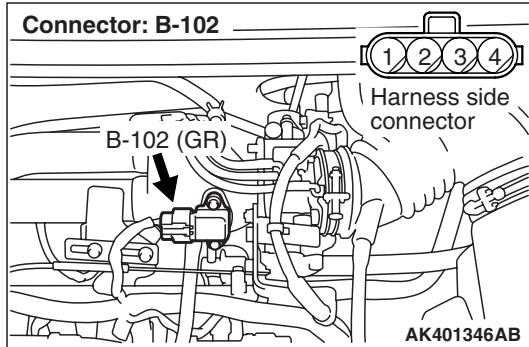

- Check output line for damage.

Q: Is the check result normal?

YES : Go to Step 16 .

NO : Repair.

STEP 16. Connector check: C-129 engine-ECU <M/T> connector or C-124 engine-A/T-ECU <A/T> connector

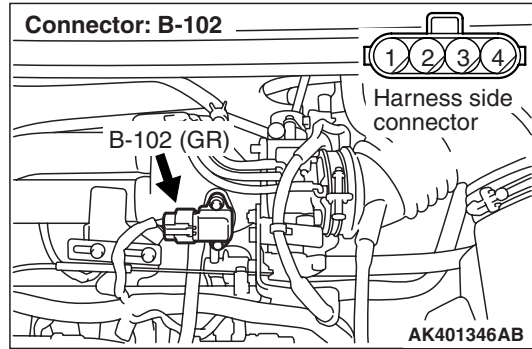
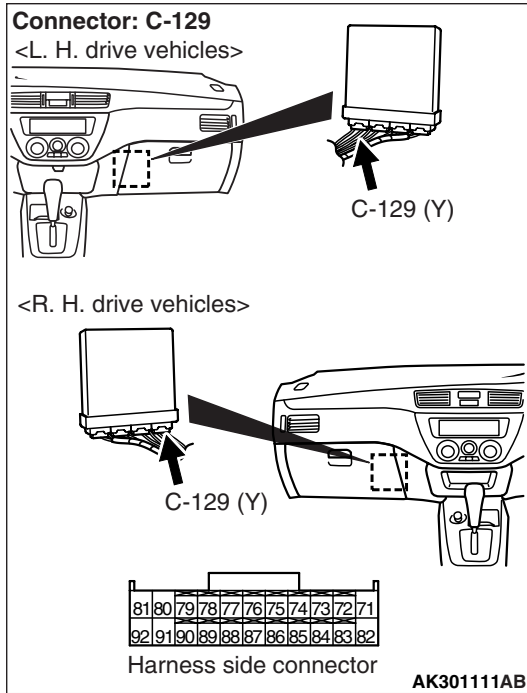

Q: Is the check result normal?

YES : Check and repair harness between B-102 (terminal No. 3) manifold absolute pressure sensor connector and C-129 (terminal No. 92) engine-ECU <M/T> connector or C-124 (terminal No. 57) engine-A/T-ECU <A/T> connector.

- Check earthing line for damage.

NO : Repair or replace.

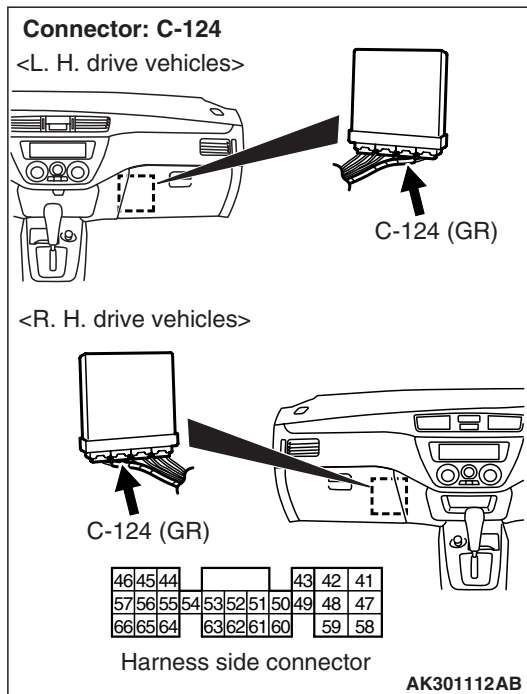

Code No. P0115: Engine Coolant Temperature Sensor System

Engine coolant temperature sensor circuit

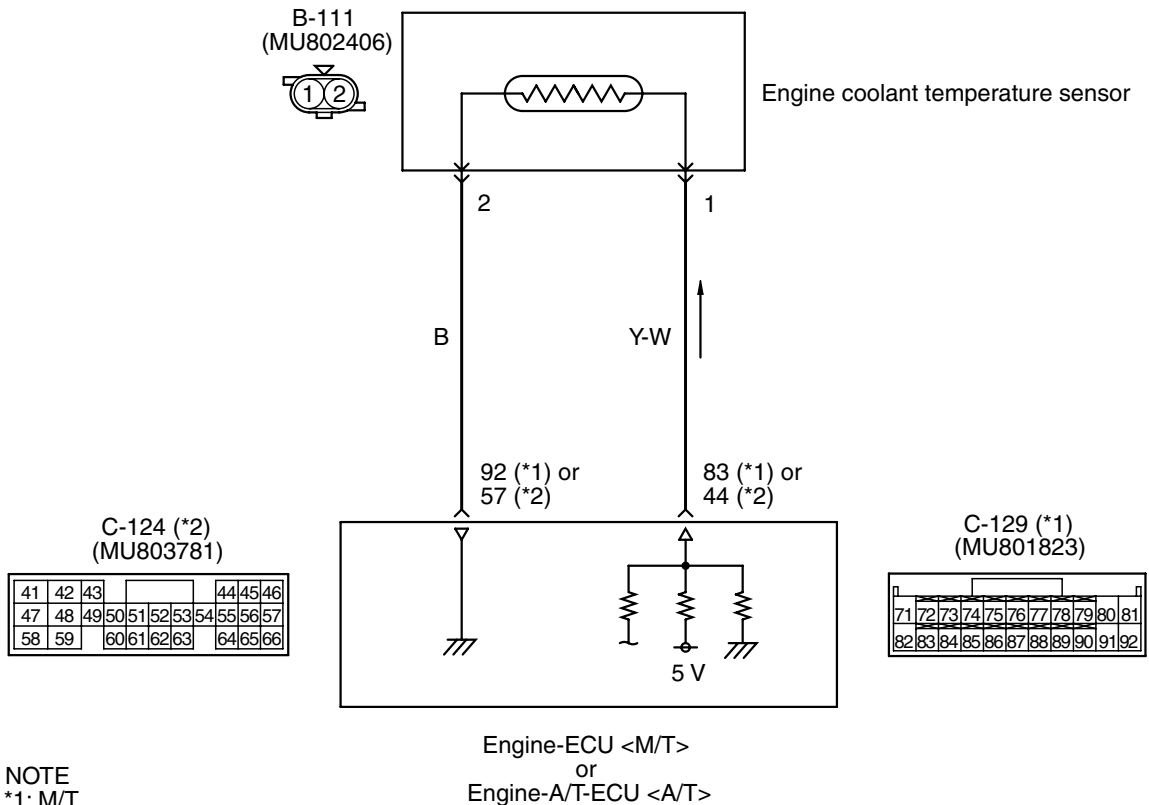

AK301114 AB

OPERATION

- A power voltage of 5 V is applied to the engine coolant temperature sensor output terminal (terminal No. 1) from the engine-ECU (terminal No. 83) <M/T> or engine-A/T-ECU (terminal No. 44) <A/T>.
- The power voltage is earthed to the engine-ECU (terminal No. 92) <M/T> or engine-A/T-ECU (terminal No. 57) <A/T> from the engine coolant temperature sensor (terminal No. 2).

- In response to the signal, the engine-ECU <M/T> or engine-A/T-ECU <A/T> controls the fuel injection amount and the fast idle speed when the engine is cold state.
- The engine coolant temperature sensor is a kind of resistor, which has characteristics to reduce its resistance as the engine coolant temperature rises. Therefore, the sensor output voltage varies with the engine coolant temperature, and becomes lower as the engine coolant temperature rises.

FUNCTION

- The engine coolant temperature sensor converts the engine coolant temperature into a voltage signal, and inputs the voltage to the engine-ECU <M/T> or engine-A/T-ECU <A/T>.

TROUBLE JUDGMENT

Check Condition

- 2 seconds later after the ignition switch has been in "ON" position or just after the engine has started up.

Judgment Criteria

- The sensor output voltage is 4.6 V or more (engine coolant temperature of below -45°C or equivalent) for 2 seconds.

or

- The sensor output voltage is 0.1 V or less (engine coolant temperature of above 140°C or equivalent) for 2 seconds.

Check Condition

- After the engine has started up.

Judging Conditions

- The sensor output voltage rises 1.6 V or more (engine coolant temperature below 40°C or equivalent) from 1.6 V or less (engine coolant temperature above 40°C or equivalent).

PROBABLE CAUSE

- Failed engine coolant temperature sensor
- Open/short circuit in engine coolant temperature sensor circuit or loose connector contact
- Failed engine-ECU <M/T>
- Failed engine-A/T-ECU <A/T>

DIAGNOSIS PROCEDURE**STEP 1. M.U.T.-II/III data list**

- Refer to data list reference table [P.13A-376](#).
 - Item 21: Engine coolant temperature sensor

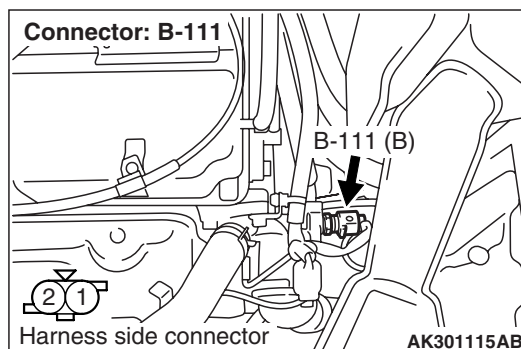
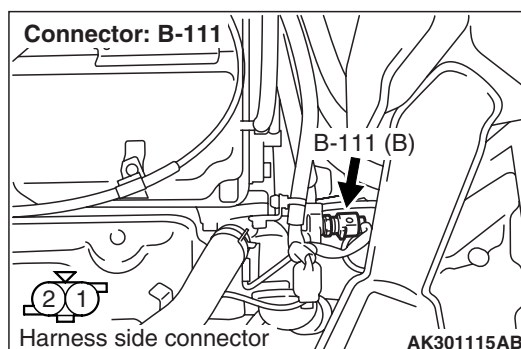
OK:**Engine cold state: At ambient temperature or equivalent.****Engine hot state: At $80 - 120^{\circ}\text{C}$** **Q: Is the check result normal?****YES :** Intermittent malfunction (Refer to GROUP 00 –How to Use Troubleshooting/Inspection Service Points [P.00-5](#)).**NO :** Go to Step 2 .**STEP 2. Connector check: B-111 engine coolant temperature sensor connector****Q: Is the check result normal?****YES :** Go to Step 3 .**NO :** Repair or replace.**STEP 3. Perform resistance measurement at B-111 engine coolant temperature sensor connector.**

- Disconnect connector, and measure at sensor side.
- Resistance between terminal No. 1 and No. 2.

OK:**Engine coolant temperature at -20°C : 14 –17 k Ω** **Engine coolant temperature at 0°C : 5.1 – 6.5 k Ω** **Engine coolant temperature at 20°C : 2.1 – 2.7 k Ω** **Engine coolant temperature at 40°C : 0.9 – 1.3 k Ω** **Engine coolant temperature at 60°C : 0.48 – 0.68 k Ω** **Engine coolant temperature at 80°C : 0.26 – 0.36 k Ω** **Q: Is the check result normal?****YES :** Go to Step 4 .**NO :** Replace engine coolant temperature sensor.

STEP 4. Perform voltage measurement at B-111 engine coolant temperature sensor connector.

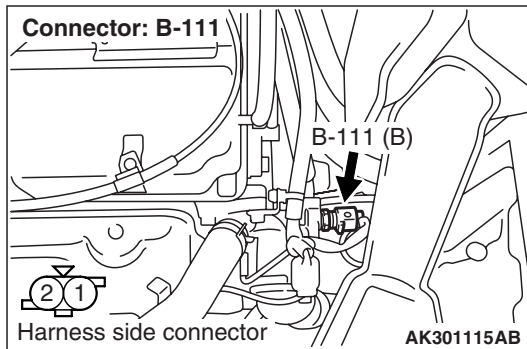

- Disconnect connector, and measure at harness side.
- Ignition switch: ON
- Voltage between terminal No. 1 and earth.
OK: 4.5 – 4.9 V

Q: Is the check result normal?
YES : Go to Step 10 .
NO : Go to Step 5 .

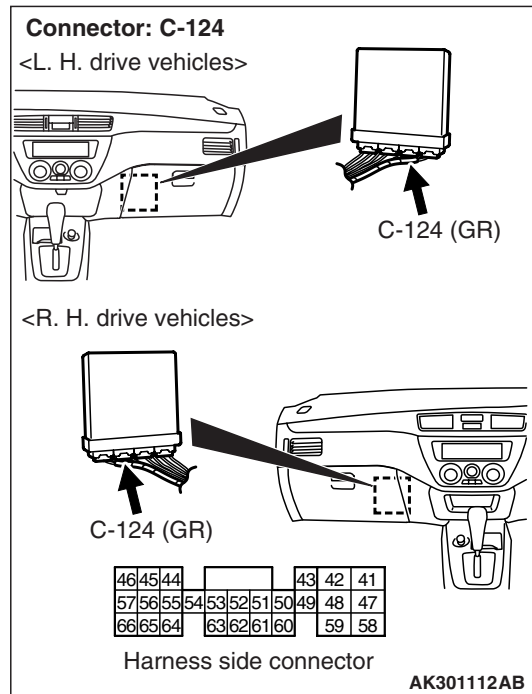

STEP 5. Perform voltage measurement at C-129 engine-ECU <M/T> connector or C-124 engine-A/T-ECU <A/T> connector.

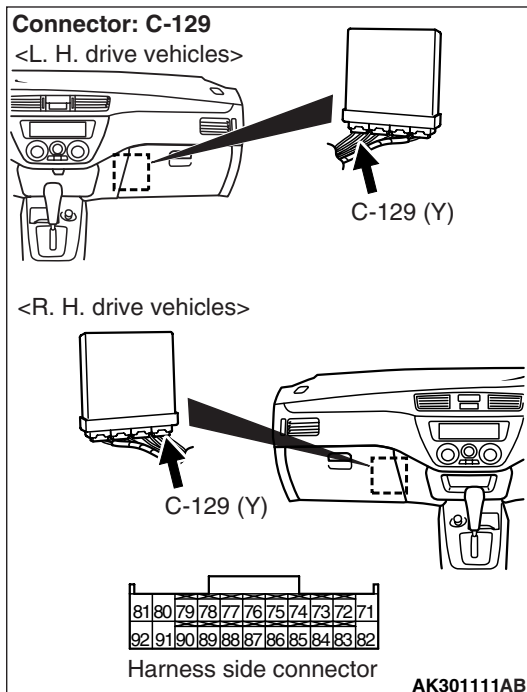

- Measure engine-ECU <M/T> or engine-A/T-ECU <A/T> terminal voltage.
- Disconnect B-111 engine coolant temperature sensor.
- Ignition switch: ON
- Voltage between terminal No. 83 <M/T> or terminal No. 44 <A/T> and earth.
OK: 4.5 – 4.9 V

Q: Is the check result normal?
YES : Go to Step 6 .
NO : Go to Step 7 .

STEP 6. Connector check: C-129 engine-ECU <M/T> connector or C-124 engine-A/T-ECU <A/T> connector

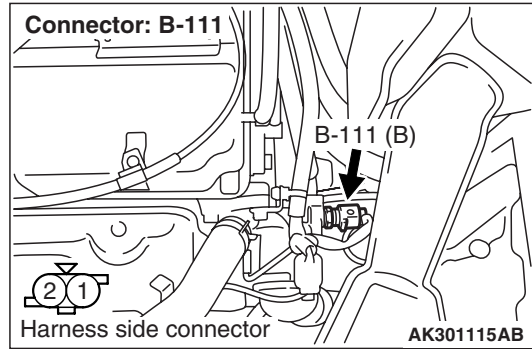
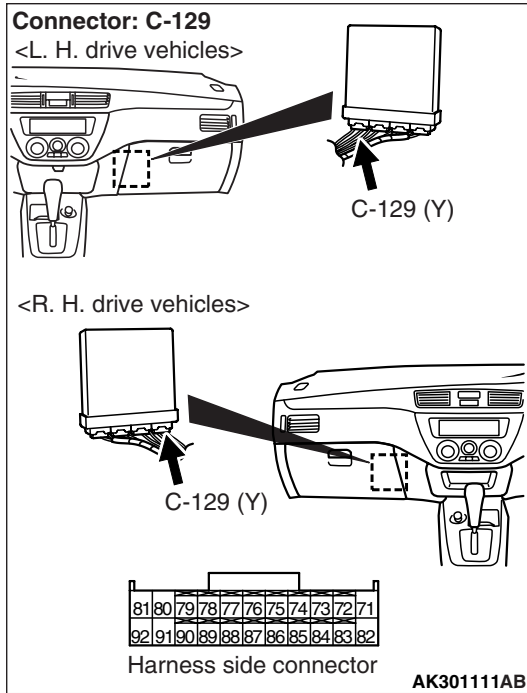

Q: Is the check result normal?

YES : Check and repair harness between B-111 (terminal No. 1) engine coolant temperature sensor connector and C-129 (terminal No. 83) engine-ECU <M/T> connector or C-124 (terminal No. 44) engine-A/T-ECU <A/T> connector.

- Check output line for open circuit.

NO : Repair or replace.

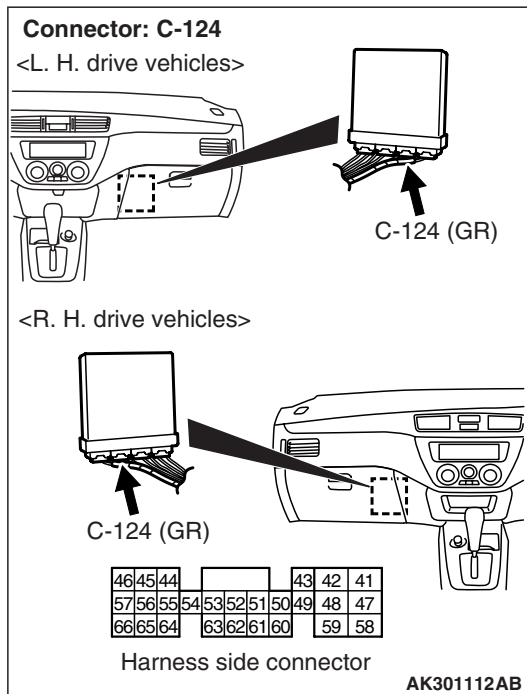

**STEP 7. Connector check: C-129 engine-ECU
<M/T> connector or C-124 engine-A/T-ECU <A/T>
connector**

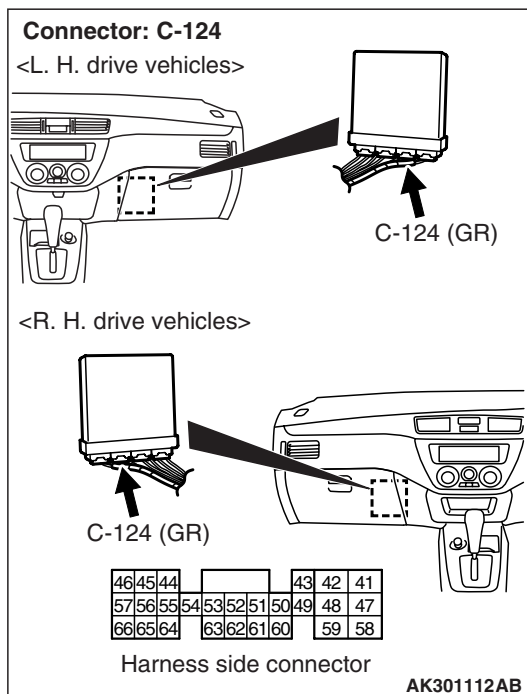
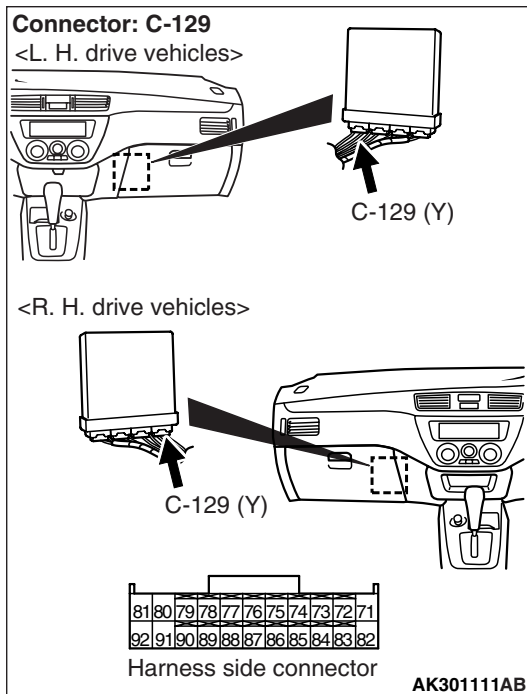

Q: Is the check result normal?

YES : Go to Step 8 .

NO : Repair or replace.

STEP 8. Check harness between B-111 (terminal No. 1) engine coolant temperature sensor connector and C-129 (terminal No. 83) engine-ECU <M/T> connector or C-124 (terminal No. 44) engine-A/T-ECU <A/T> connector.

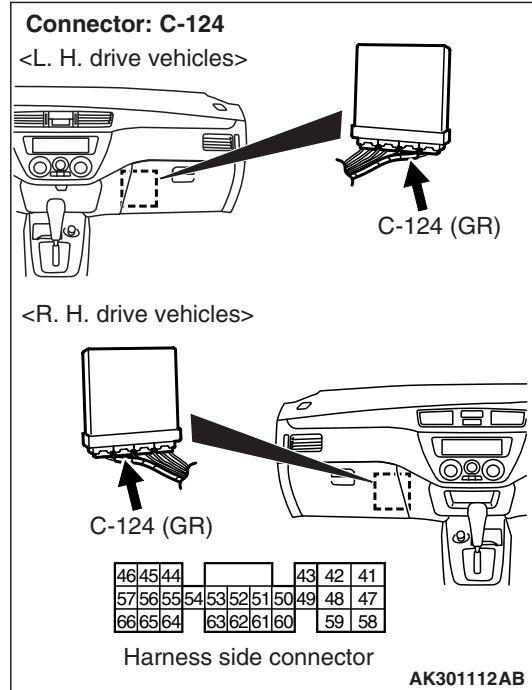
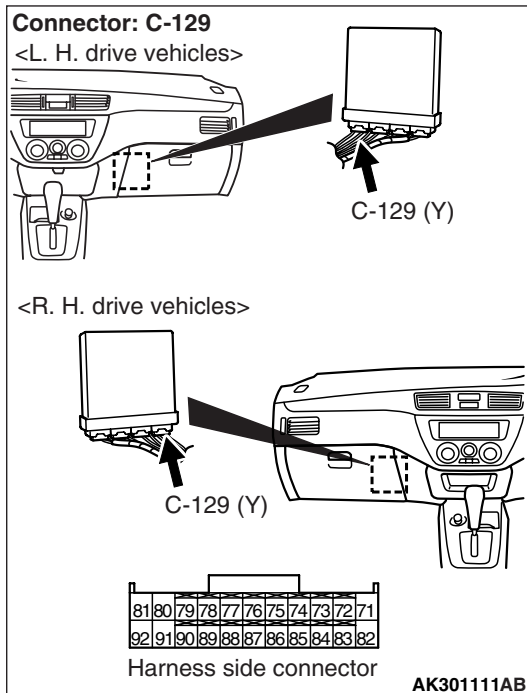
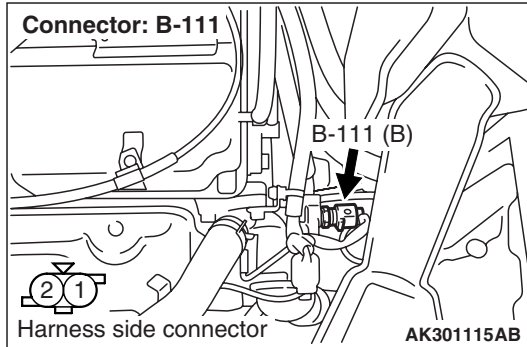

- Check output line for short circuit.

Q: Is the check result normal?

YES : Go to Step 9 .

NO : Repair.

STEP 9. M.U.T.-II/III data list

- Refer to data list reference table [P.13A-376](#).
 - a. Item 21: Engine coolant temperature sensor

OK:

Engine cold state: At ambient temperature or equivalent.

Engine hot state: At 80 – 120 °C

Q: Is the check result normal?

YES : Intermittent malfunction (Refer to GROUP 00 –How to Use Troubleshooting/Inspection Service Points [P.00-5](#)).

NO : Replace engine-ECU <M/T> or engine-A/T-ECU <A/T>.

STEP 10. Perform resistance measurement at B-111 engine coolant temperature sensor connector.

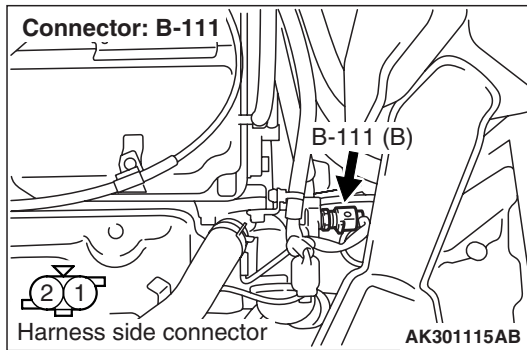

- Disconnect connector and measure at harness side.
- Resistance between terminal No. 2 and earth.

OK: Continuity (2 Ω or less)

Q: Is the check result normal?

YES : Go to Step 13 .

NO : Go to Step 11 .

STEP 11. Connector check: C-129 engine-ECU <M/T> connector or C-124 engine-A/T-ECU <A/T> connector

Q: Is the check result normal?

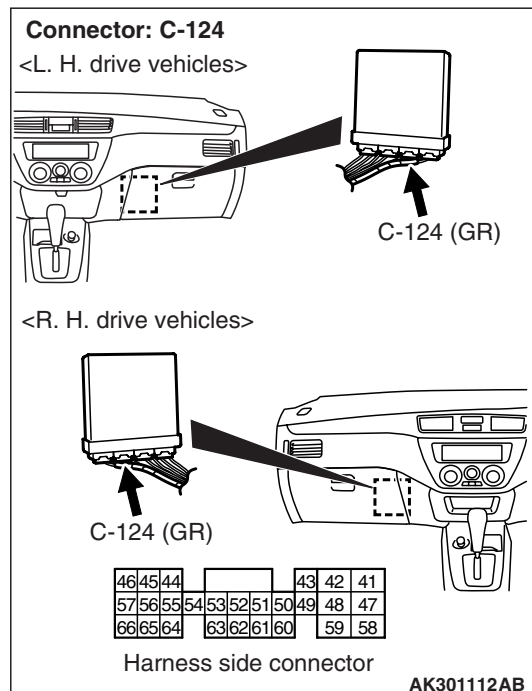
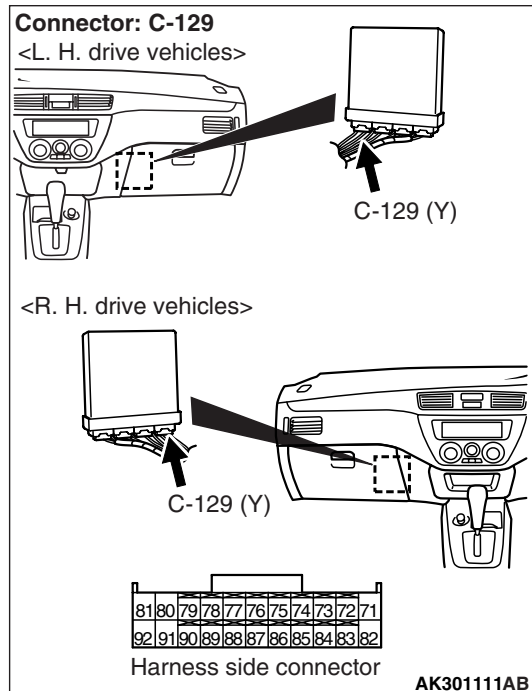

YES : Go to Step 12 .

NO : Repair or replace.

STEP 12. Check harness between B-111 (terminal No. 2) engine coolant temperature sensor connector and C-129 (terminal No. 92) engine-ECU <M/T> connector or C-124 (terminal No. 57) engine-A/T-ECU <A/T> connector.

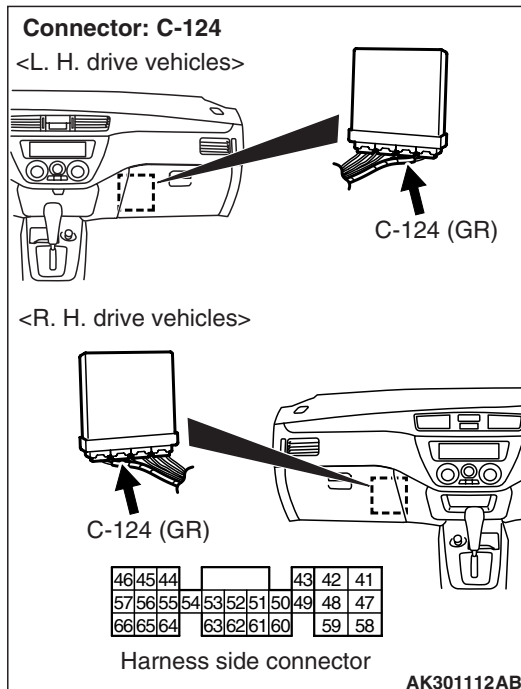
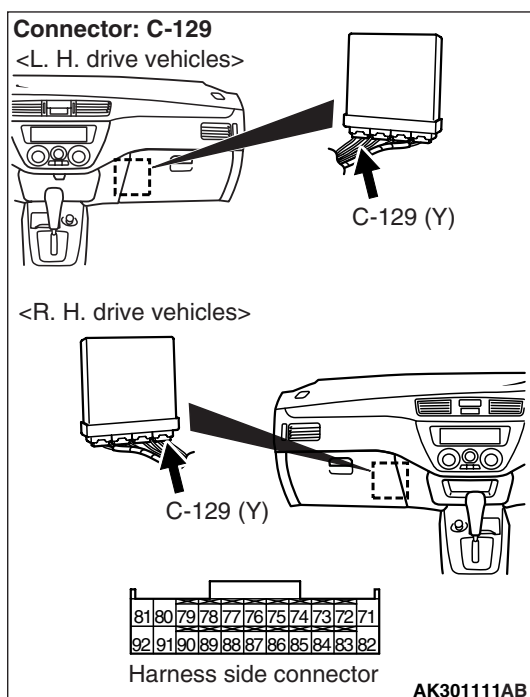
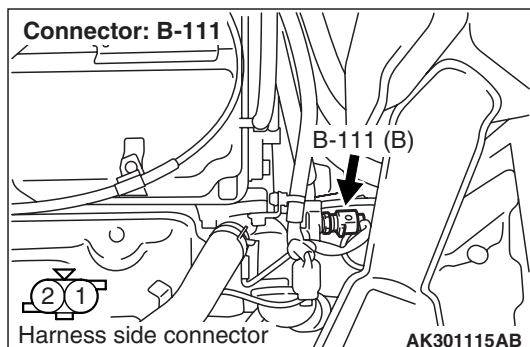

- Check earthing line for open circuit and damage.

Q: Is the check result normal?

- YES :** Go to Step 9 .
NO : Repair.

STEP 13. Perform voltage measurement at B-111 engine coolant temperature sensor connector.

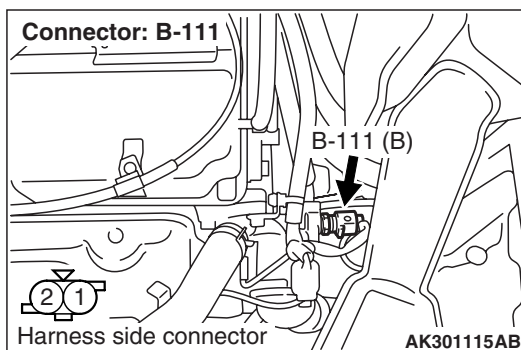

- Use special tool test harness (MB991658) to connect connector, and measure at pick-up harness.
- Ignition switch: ON
- Voltage between terminal No. 1 and earth.

OK:

Engine coolant temperature at -20° C: 3.9 – 4.5 V

Engine coolant temperature at 0° C: 3.2 – 3.8 V

Engine coolant temperature at 20° C: 2.3 – 2.9 V

Engine coolant temperature at 40° C: 1.3 – 1.9 V

Engine coolant temperature at 60° C: 0.7 – 1.3 V

Engine coolant temperature at 80° C: 0.3 – 0.9 V

Q: Is the check result normal?

- YES :** Go to Step 9 .
NO : Go to Step 14 .

**STEP 14. Connector check: C-129 engine-ECU
<M/T> connector or C-124 engine-A/T-ECU <A/T>
connector**

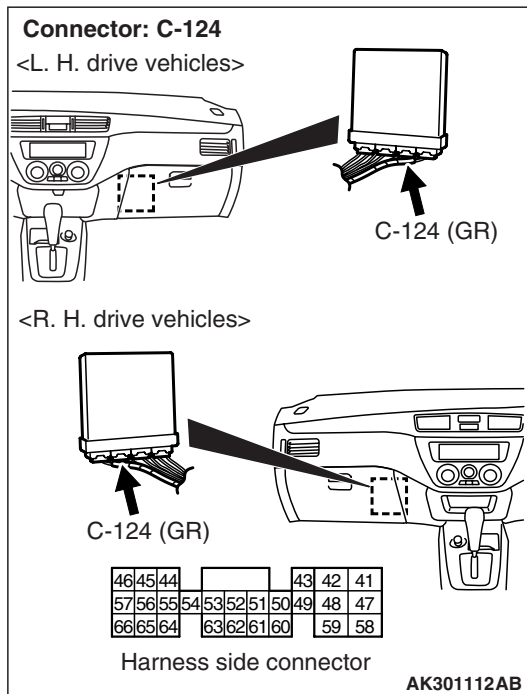
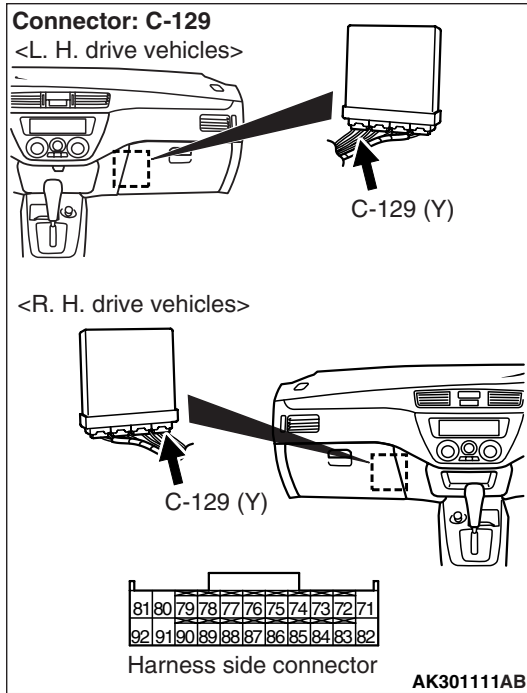

Q: Is the check result normal?

YES : Go to Step 15 .

NO : Repair or replace.

STEP 15. Check harness between B-111 (terminal No. 1) engine coolant temperature sensor connector and C-129 (terminal No. 83) engine-ECU <M/T> connector or C-124 (terminal No. 44) engine-A/T-ECU <A/T> connector.

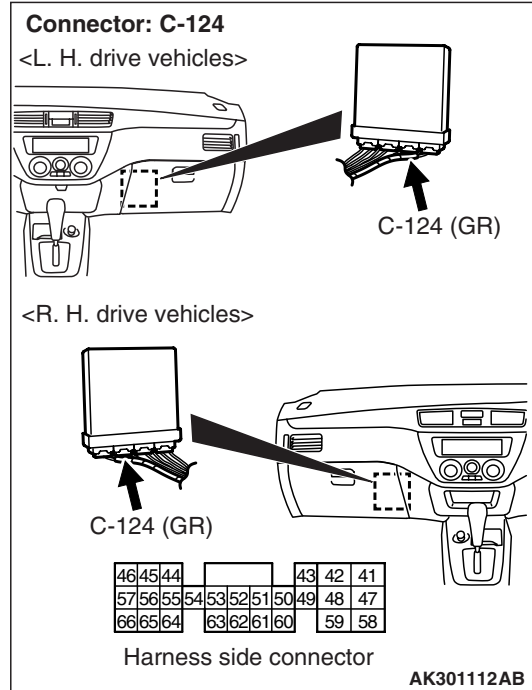
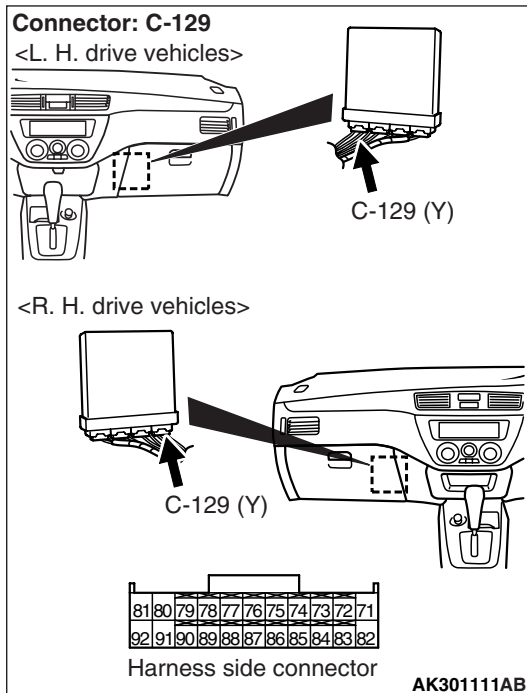
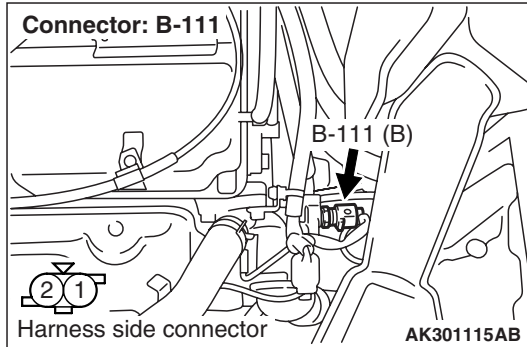

- Check output line for damage.

Q: Is the check result normal?

YES : Go to Step 16 .

NO : Repair.

STEP 16. Connector check: C-129 engine-ECU <M/T> connector or C-124 engine-A/T-ECU <A/T> connector

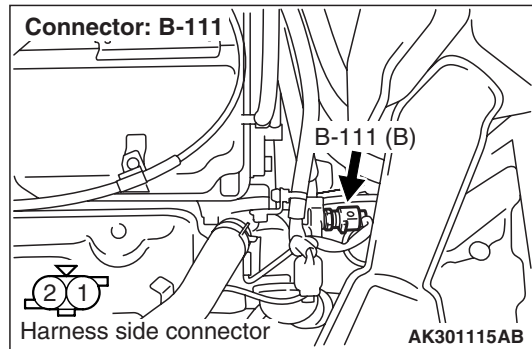
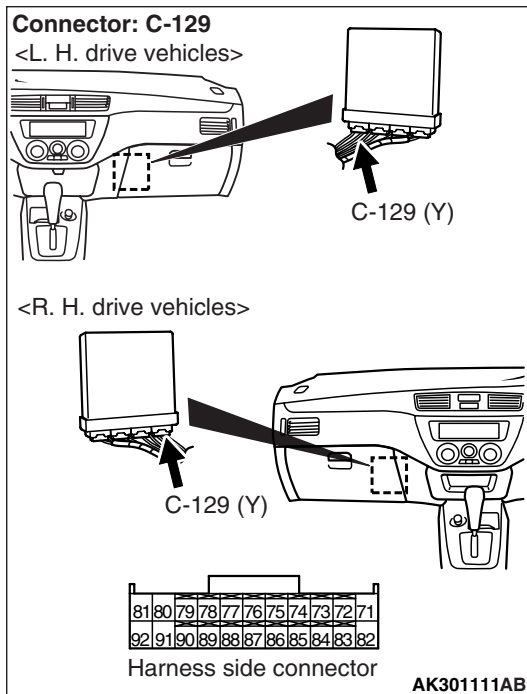

Q: Is the check result normal?

YES : Check and repair harness between B-111 (terminal No. 2) engine coolant temperature sensor connector and C-129 (terminal No. 92) engine-ECU <M/T> connector or C-124 (terminal No. 57) engine-A/T-ECU <A/T> connector.

- Check earthing line for damage.

NO : Repair or replace.

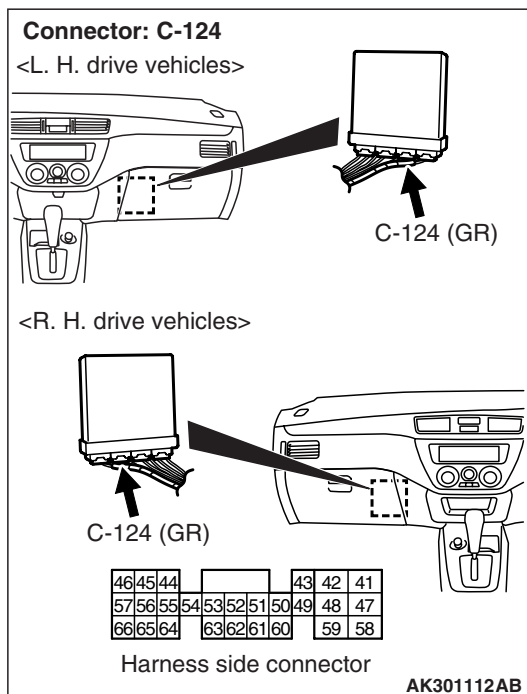

Code No. P0120: Throttle Position Sensor System

Throttle position sensor circuit

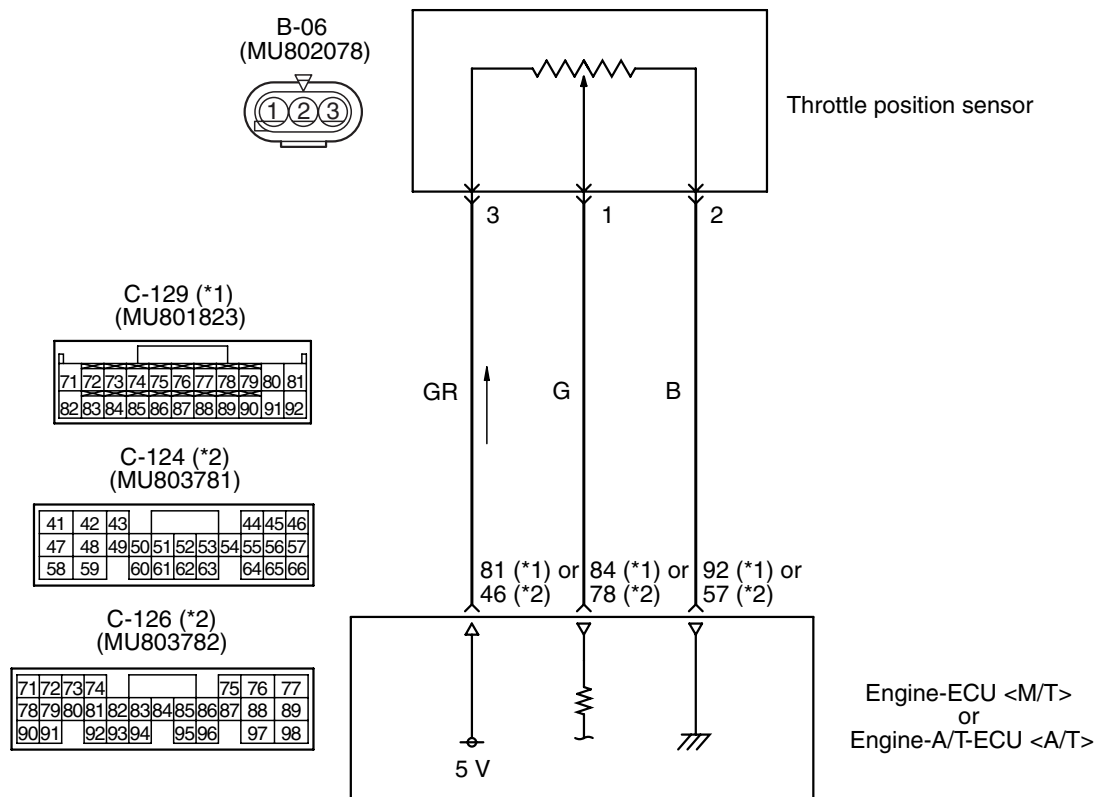

AK301116AC

OPERATION

- A power voltage of 5 V is applied to the throttle position sensor (terminal No. 3) from the engine-ECU (terminal No. 81) or engine-A/T-ECU (terminal No. 46) <A/T>.
- The power voltage is earthed to the engine-ECU (terminal No. 92) <M/T> or engine-A/T-ECU (terminal No. 46) <A/T> from the throttle position sensor (terminal No. 2).
- The sensor signal is inputted to the engine-ECU (terminal No. 84) <M/T> or engine-A/T-ECU (terminal No. 78) <A/T> from the throttle position sensor output terminal (terminal No. 1).

FUNCTION

- The throttle position sensor converts the opening of the throttle valve into a voltage and inputs the voltage signal to the engine-ECU <M/T> or engine-A/T-ECU <A/T>.
- In response to the signal, the engine-ECU <M/T> or engine-A/T-ECU <A/T> checks the opening of the throttle valve.

TROUBLE JUDGMENT

Check Condition

- Ignition switch: ON (Excluding 2 seconds after the ignition switch has been in "ON" position or just after the engine has started up.)

Judgment Criteria

- The sensor output voltage is 0.2 V or less for 2 seconds.
- or
- When the engine speed is 1,000 r/min or less and intake air pressure is 48 kPa or less, the throttle position sensor output voltage is 4.6 V or more for 2 seconds.

PROBABLE CAUSE

- Failed throttle position sensor
- Open/short circuit in throttle position sensor circuit or loose connector contact
- Failed engine-ECU <M/T>
- Failed engine-A/T-ECU <A/T>

DIAGNOSIS PROCEDURE

STEP 1. M.U.T.-II/III data list

- Refer to data list reference table [P.13A-376](#).
 - Item 14: Throttle position sensor

Q: Is the check result normal?

YES : Intermittent malfunction (Refer to GROUP 00 –How to Use Troubleshooting/Inspection Service Points [P.00-5](#)).

NO : Go to Step 2 .

STEP 2. Connector check: B-06 throttle position sensor connector

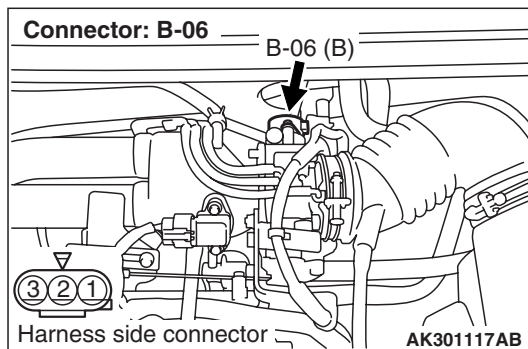

Q: Is the check result normal?

YES : Go to Step 3 .

NO : Repair or replace.

STEP 3. Check throttle position sensor itself.

- Check throttle position sensor itself (Refer to [P.13A-406](#)).

Q: Is the check result normal?

YES : Go to Step 4 .

NO : Replace throttle position sensor.

STEP 4. Perform voltage measurement at B-06 throttle position sensor connector.

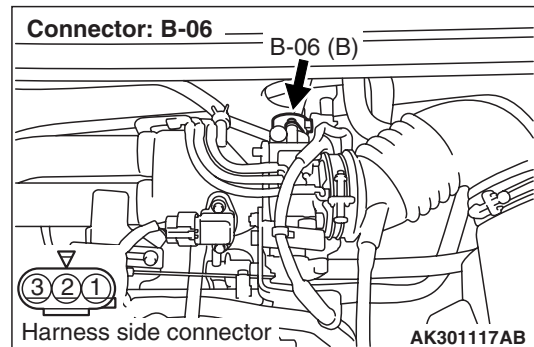

- Disconnect connector, and measure at harness side.
- Ignition switch: ON
- Voltage between terminal No. 3 and earth.

OK: 4.9 – 5.1 V

Q: Is the check result normal?

YES : Go to Step 10 .

NO : Go to Step 5 .

STEP 5. Perform voltage measurement at C-129 engine-ECU <M/T> connector or C-124 engine-A/T-ECU <A/T> connector.

Q: Is the check result normal?

YES : Go to Step 6 .

NO : Go to Step 7 .

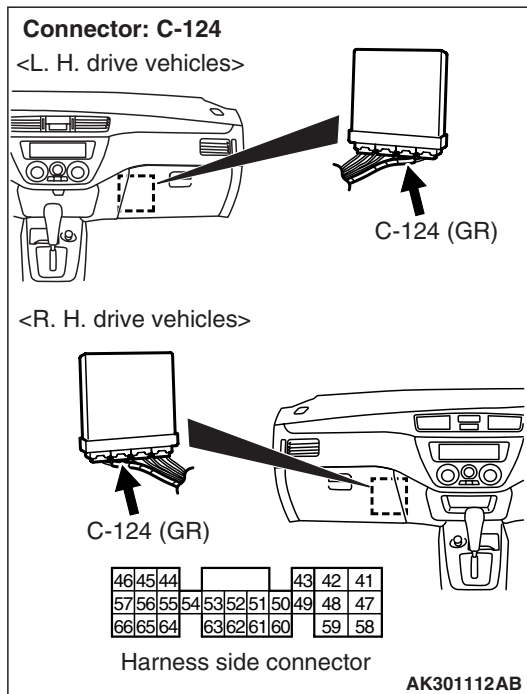
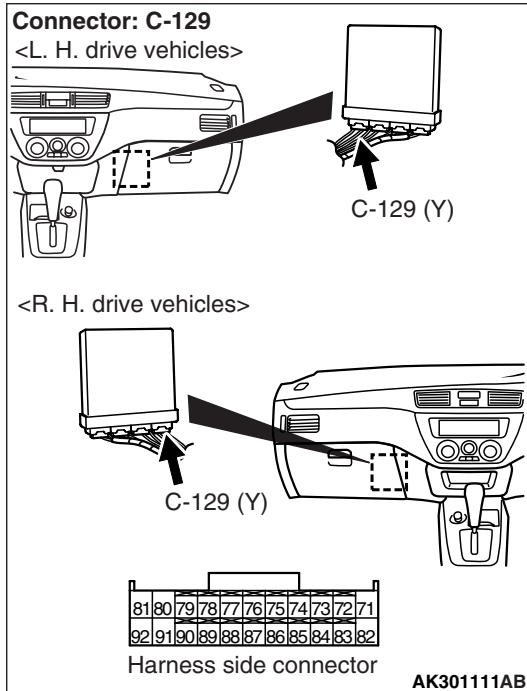

- Measure engine-ECU <M/T> or engine-A/T-ECU <A/T> terminal voltage.
- Ignition switch: ON
- Voltage between terminal No. 81 <M/T> or terminal No. 46 <A/T> and earth.

OK: 4.9 – 5.1 V

STEP 6. Connector check: C-129 engine-ECU <M/T> connector or C-124 engine-A/T-ECU <A/T> connector

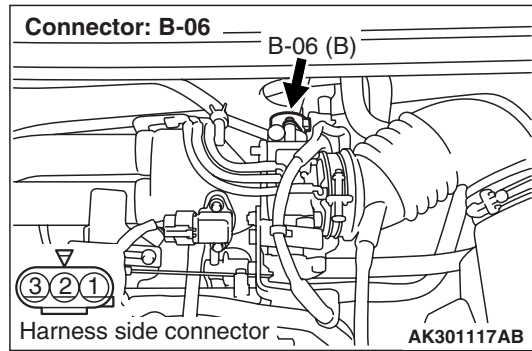
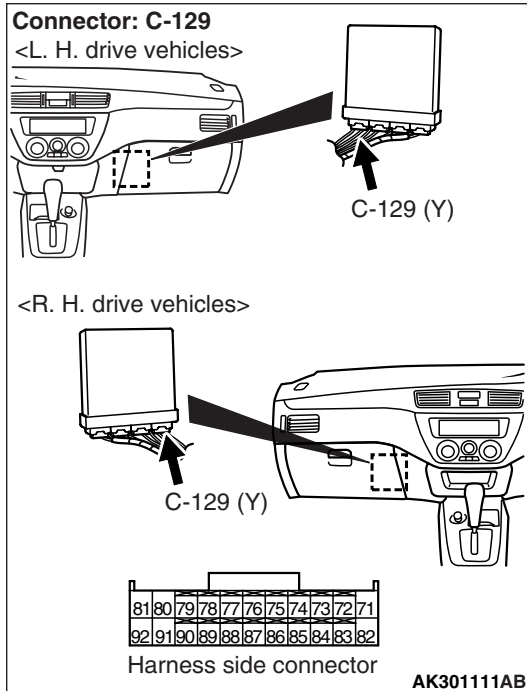

Q: Is the check result normal?

YES : Check and repair harness between B-06 (terminal No. 3) throttle position sensor connector and C-129 (terminal No. 81) engine-ECU <M/T> connector or C-124 (terminal No. 46) engine-A/T-ECU <A/T> connector.

- Check power supply line for open circuit.

NO : Repair or replace.

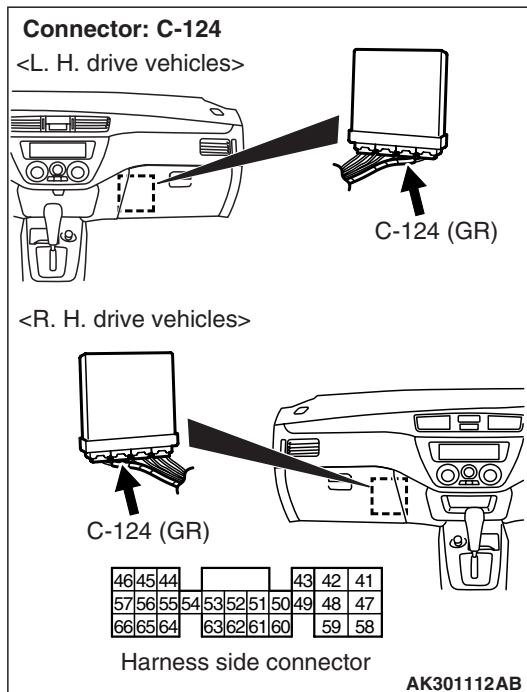

STEP 7. Connector check: C-129 engine-ECU <M/T> connector or C-124 engine-A/T-ECU <A/T> connector

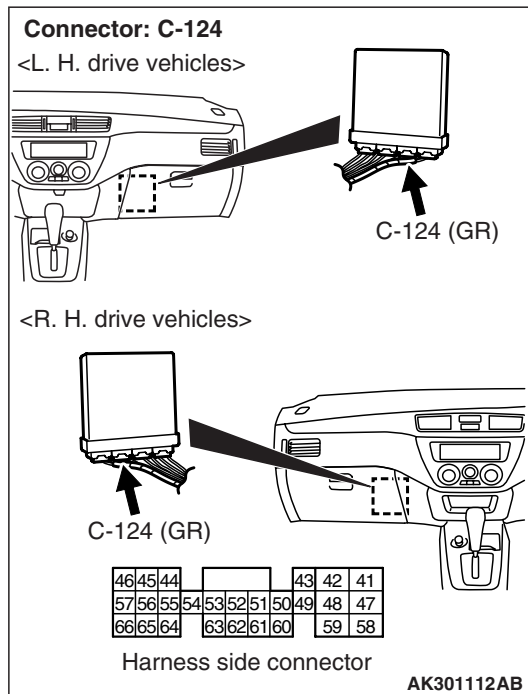
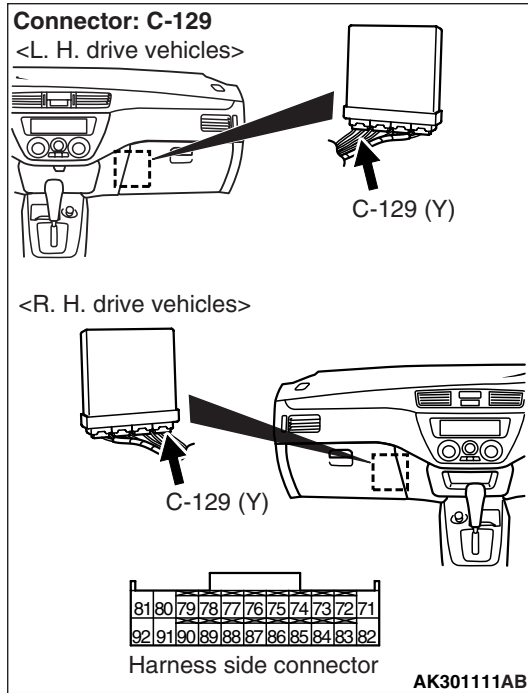

Q: Is the check result normal?

YES : Go to Step 8 .

NO : Repair or replace.

STEP 8. Check harness between B-06 (terminal No. 3) throttle position sensor connector and C-129 (terminal No. 81) engine-ECU <M/T> connector or C-124 (terminal No. 46) engine-A/T-ECU <A/T> connector.

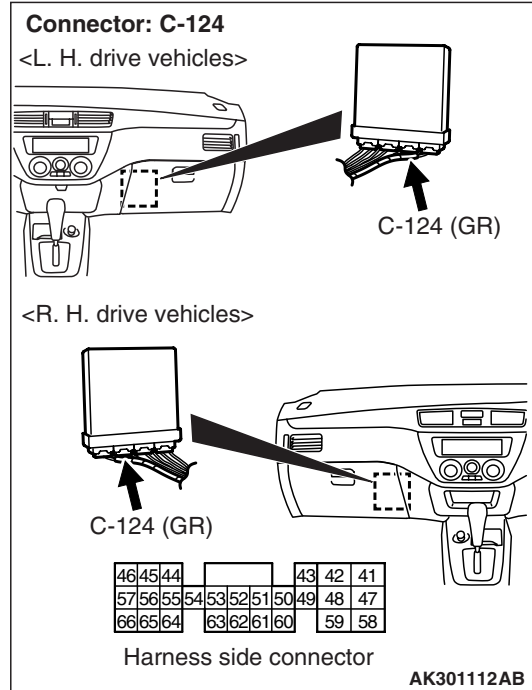
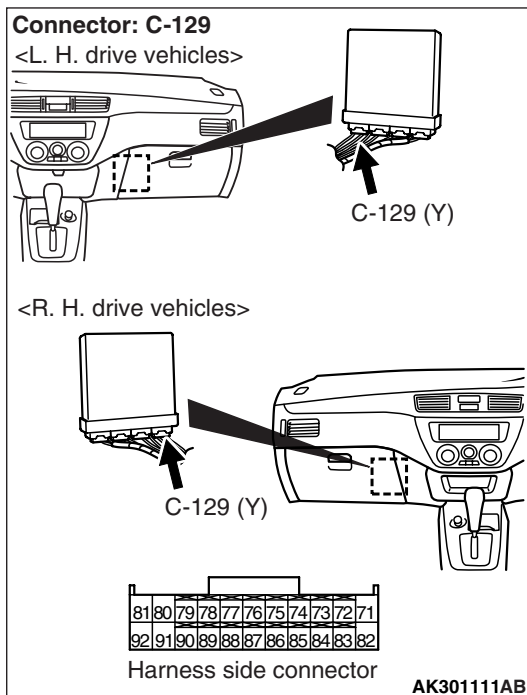
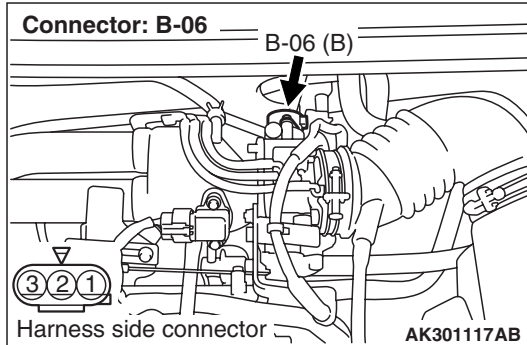

- Check power supply line for short circuit.

Q: Is the check result normal?

YES : Go to Step 9 .

NO : Repair.

STEP 9. M.U.T.-II/III data list

- Refer to data list reference table [P.13A-376](#).
 - Item 14: Throttle position sensor

Q: Is the check result normal?

YES : Intermittent malfunction (Refer to GROUP 00 –How to Use Troubleshooting/Inspection Service Points [P.00-5](#)).

NO : Replace engine-ECU <M/T> or engine-A/T-ECU <A/T>.

STEP 10. Perform resistance measurement at B-06 throttle position sensor connector.

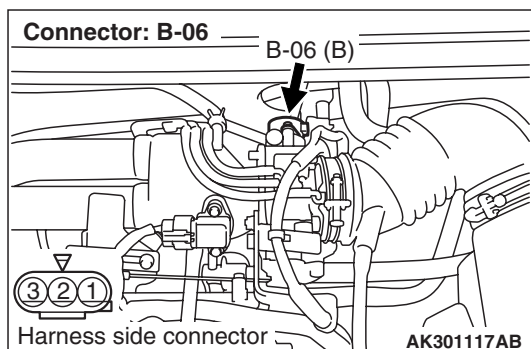

- Disconnect connector, and measure at harness side.
- Resistance between terminal No. 4 and earth.
OK: Continuity (2 Ω or less)

Q: Is the check result normal?

YES : Go to Step 13 .

NO : Go to Step 11 .

STEP 11. Connector check: C-129 engine-ECU <M/T> connector or C-124 engine-A/T-ECU <A/T> connector

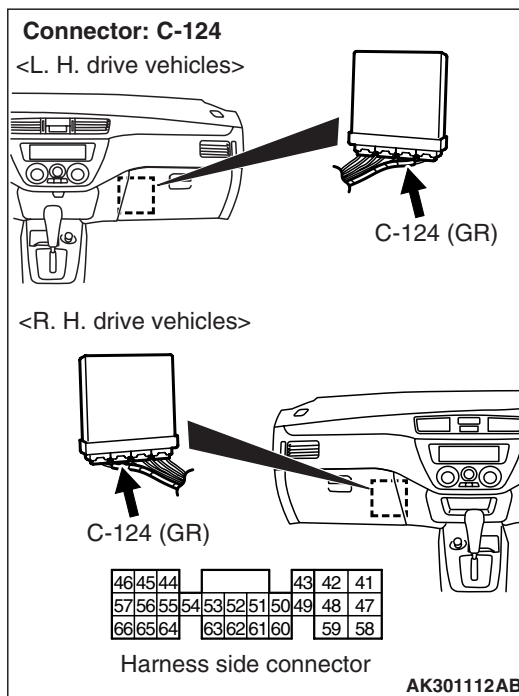
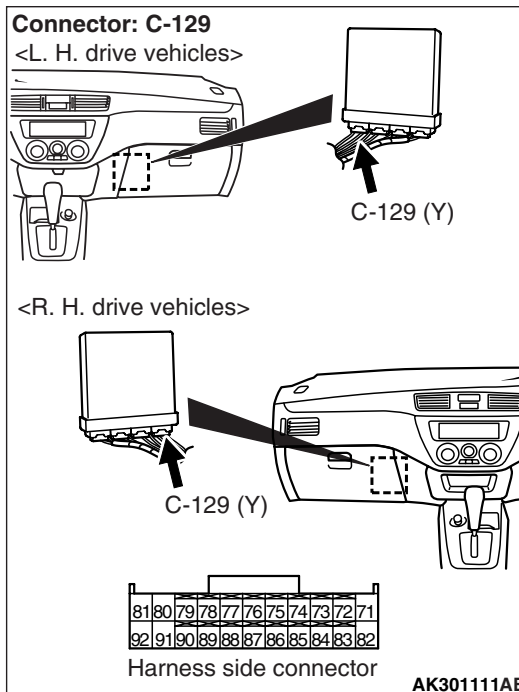

Q: Is the check result normal?

YES : Go to Step 12 .

NO : Repair or replace.

STEP 12. Check harness between B-06 (terminal No. 2) throttle position sensor connector and C-129 (terminal No. 92) engine-ECU <M/T> connector or C-124 (terminal No. 72) engine-A/T-ECU <A/T> connector.

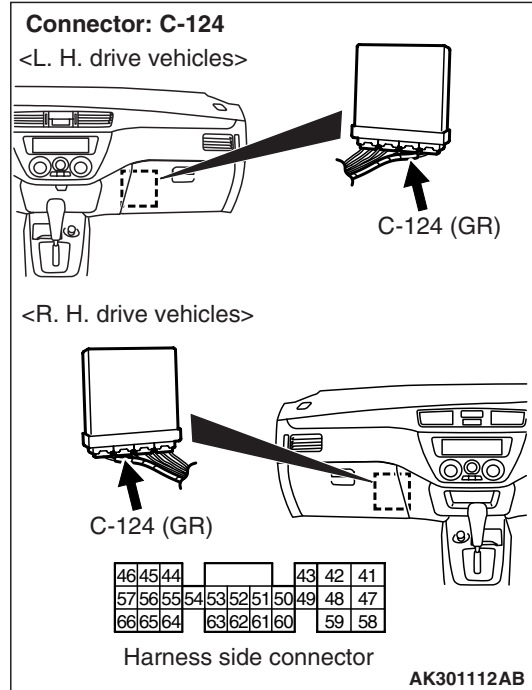
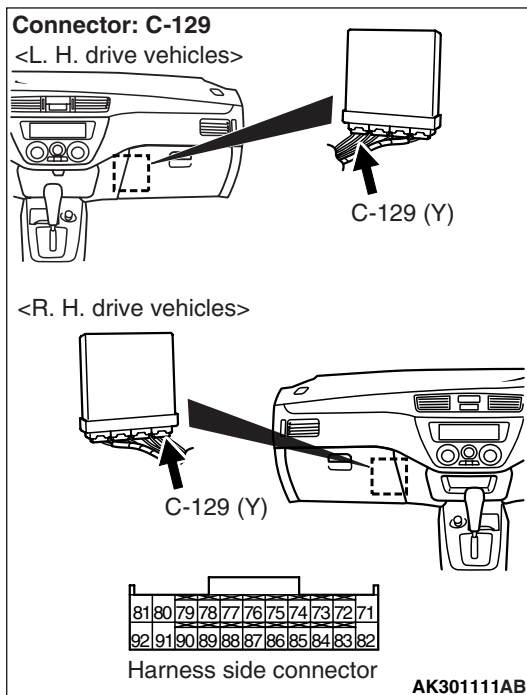
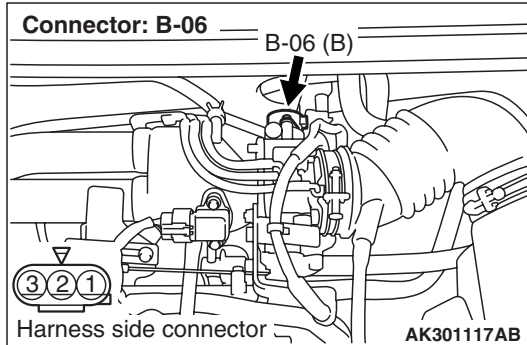

- Check earthing line for open circuit and damage.

Q: Is the check result normal?

YES : Go to Step 9 .

NO : Repair.

STEP 13. Perform voltage measurement at B-06 throttle position sensor connector.

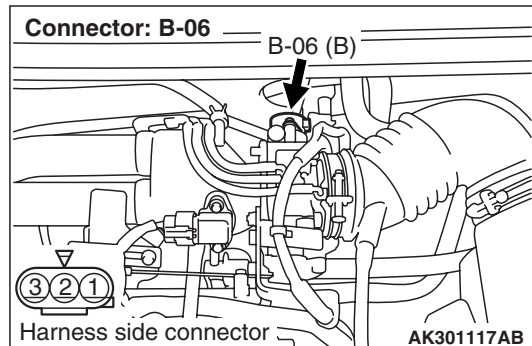

- Use special tool test harness (MB991536) to connect connector, and measure at pick-up harness.
- Ignition switch: ON
- Voltage between terminal No. 3 and earth.

OK: 4.9 – 5.1 V

Q: Is the check result normal?

YES : Go to Step 15 .

NO : Go to Step 14 .

STEP 14. Connector check: C-129 engine-ECU <M/T> connector or C-124 engine-A/T-ECU <A/T> connector

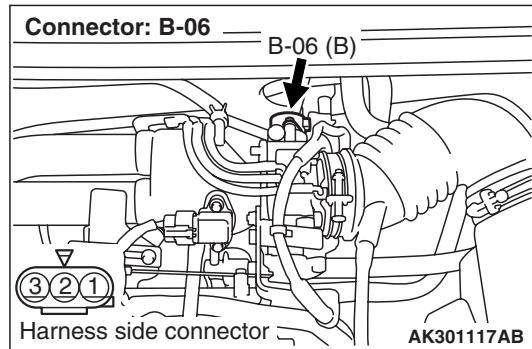
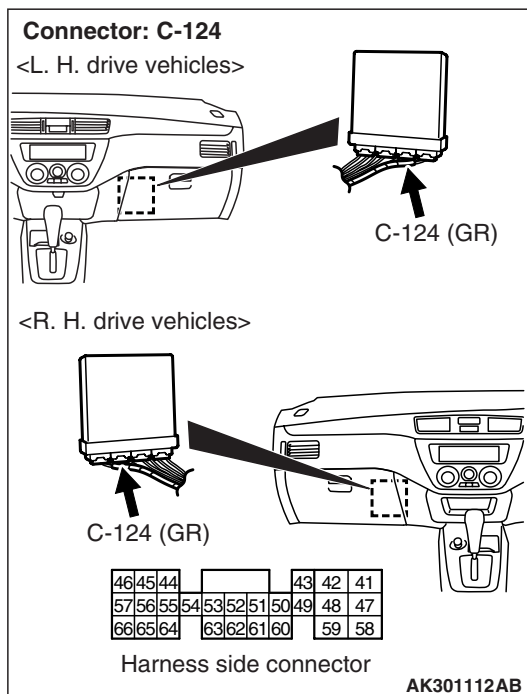
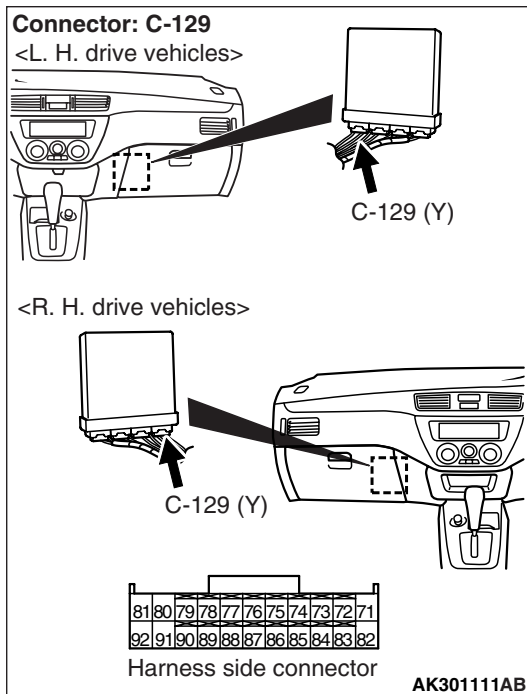

Q: Is the check result normal?

YES : Check and repair harness between B-06 (terminal No. 3) throttle position sensor connector and C-129 (terminal No. 81) engine-ECU <M/T> connector or C-124 (terminal No. 46) engine-A/T-ECU <A/T> connector.

- Check power supply line for damage.

NO : Repair or replace.

STEP 15. Perform voltage measurement at B-06 throttle position sensor connector.

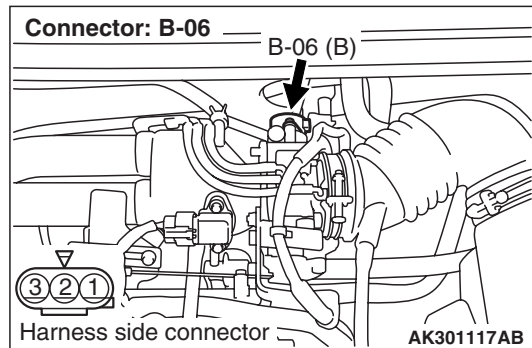

- Use special tool test harness (MB991536) to connect connector, and measure at pick-up harness.
- Ignition switch: ON
- Voltage between terminal No. 2 and earth.

OK: 0.5 V or less

Q: Is the check result normal?

YES : Go to Step 17 .

NO : Go to Step 16 .

STEP 16. Connector check: C-129 engine-ECU <M/T> connector or C-124 engine-A/T-ECU <A/T> connector

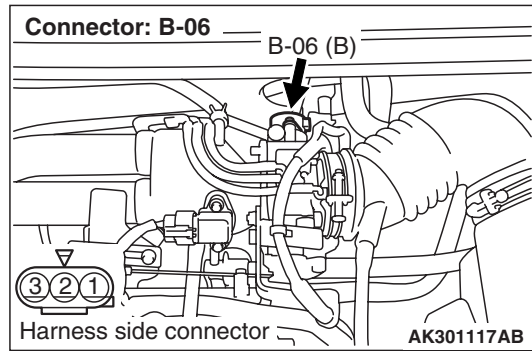
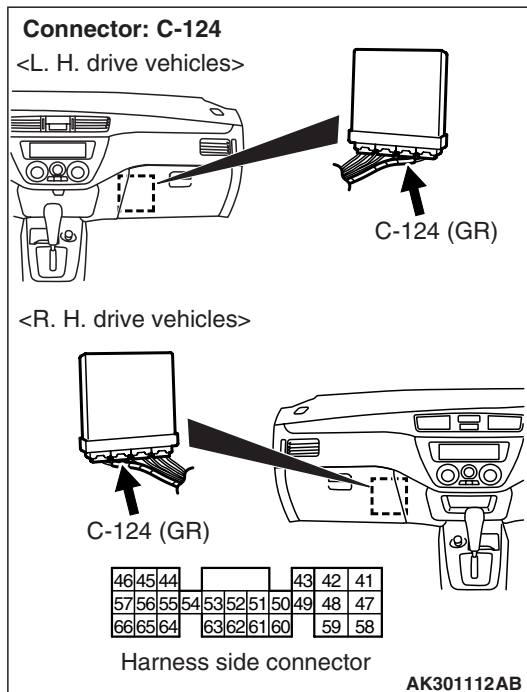
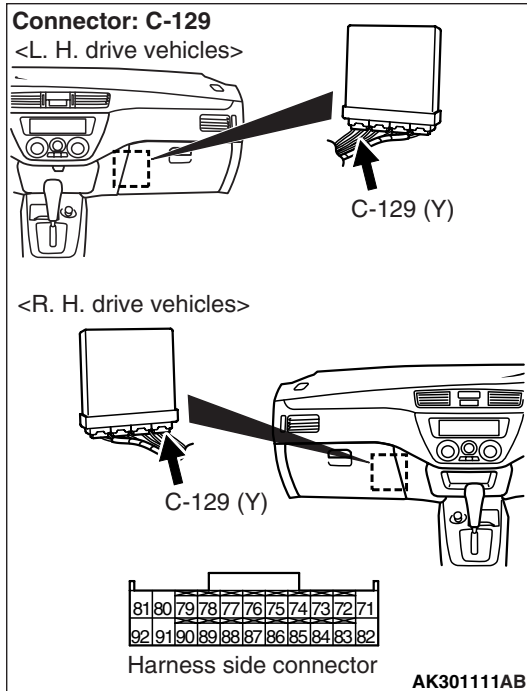

Q: Is the check result normal?

YES : Check and repair harness between B-06 (terminal No. 2) throttle position sensor connector and C-129 (terminal No. 92) engine-ECU <M/T> connector or C-124 (terminal No. 57) engine-A/T-ECU <A/T> connector.

- Check earthing line for damage.

NO : Repair or replace.

STEP 17. Perform voltage measurement at B-06 throttle position sensor connector.

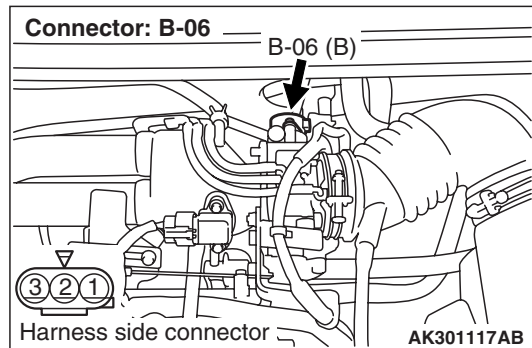

- Use special tool test harness (MB991536) to connect connector, and measure at pick-up harness.
- Ignition switch: ON
- Voltage between terminal No. 1 and earth.

OK:

Accelerator pedal fully released: 0.335 – 0.935 V

Accelerator pedal fully depressed: 4.5 – 5.0 V

Q: Is the check result normal?

YES : Go to Step 20 .

NO : Go to Step 18 .

STEP 18. Adjust throttle position sensor

- Adjust throttle position sensor (Refer to [P.13A-398](#)).

Q: Is the adjusted value normal?

YES : Go to Step 19 .

NO : Adjust throttle position sensor.

STEP 19. Connector check: C-129 engine-ECU <M/T> connector or C-126 engine-A/T-ECU <A/T> connector

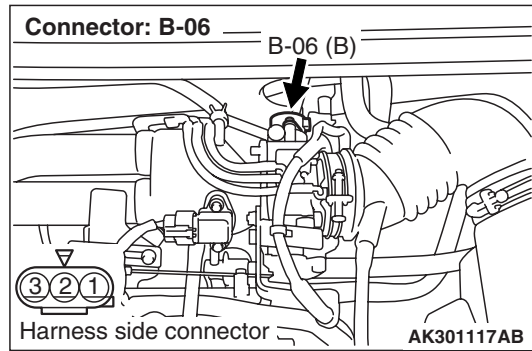
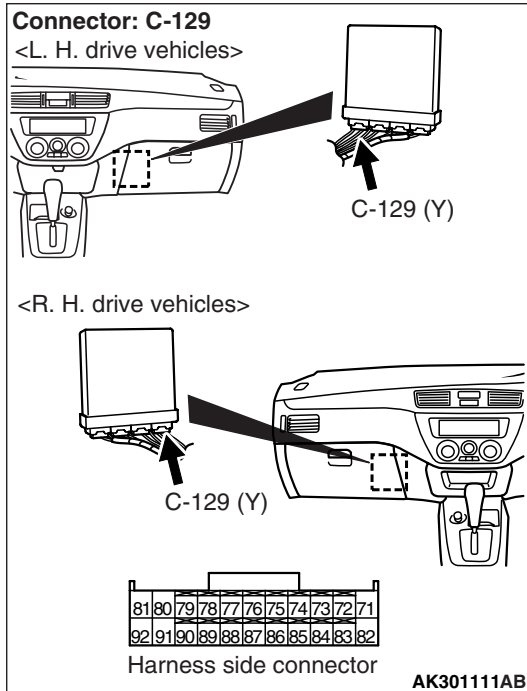

Q: Is the check result normal?

YES : Check and repair harness between B-06 (terminal No. 1) throttle position sensor connector and C-129 (terminal No. 84) engine-ECU <M/T> connector or C-126 (terminal No. 78) engine-A/T-ECU <A/T> connector.

- Check output line for short circuit and damage.

NO : Repair or replace.

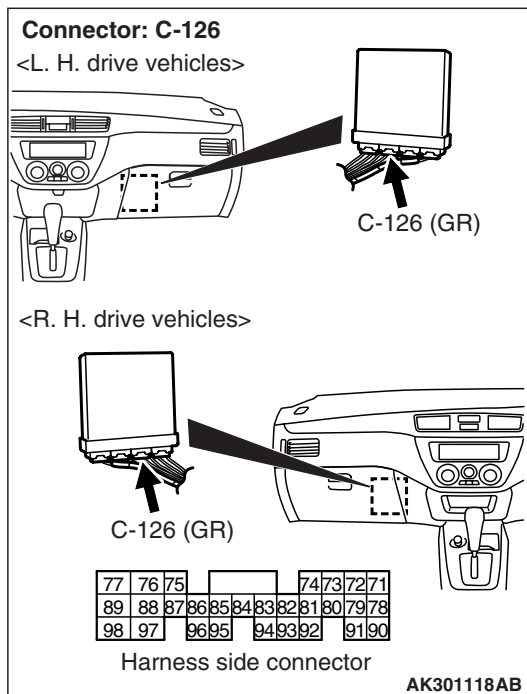

STEP 20. Perform voltage measurement at C-129 engine-ECU <M/T> connector or C-126 engine-A/T-ECU <A/T> connector

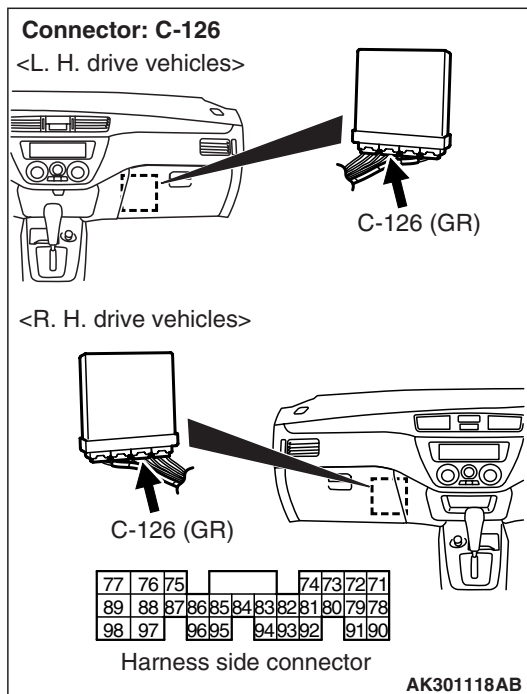
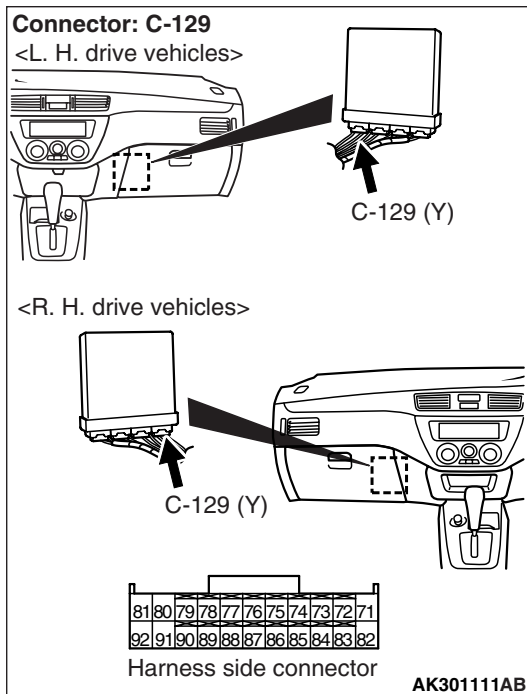

- OK:**
Accelerator pedal fully released: 0.335 – 0.935 V
V
Accelerator pedal fully depressed: 4.5 – 5.0 V
- Q: Is the check result normal?**
YES : Go to Step 22 .
NO : Go to Step 21 .

- Measure engine-ECU <M/T> or engine-A/T-ECU <A/T> terminal voltage.
- Ignition switch: ON
- Voltage between terminal No. 84 <M/T> or terminal No. 78 <A/T> and earth.

STEP 21. Connector check: C-129 engine-ECU <M/T> connector or C-126 engine-A/T-ECU <A/T> connector

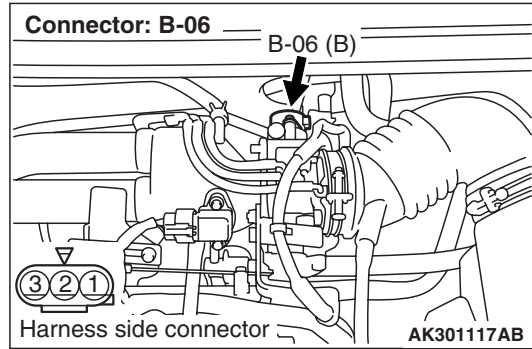
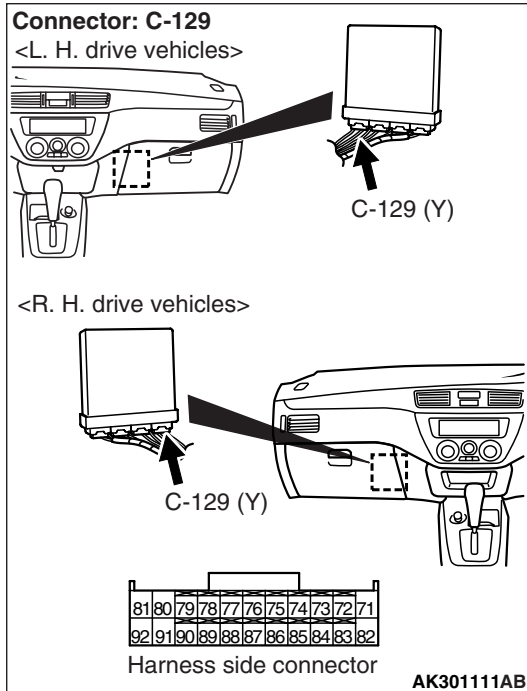

Q: Is the check result normal?

YES : Check and repair harness between B-06 (terminal No. 1) throttle position sensor connector and C-129 (terminal No. 84) engine-ECU <M/T> connector or C-126 (terminal No. 78) engine-A/T-ECU <A/T> connector.

- Check output line for open circuit and damage.

NO : Repair or replace.

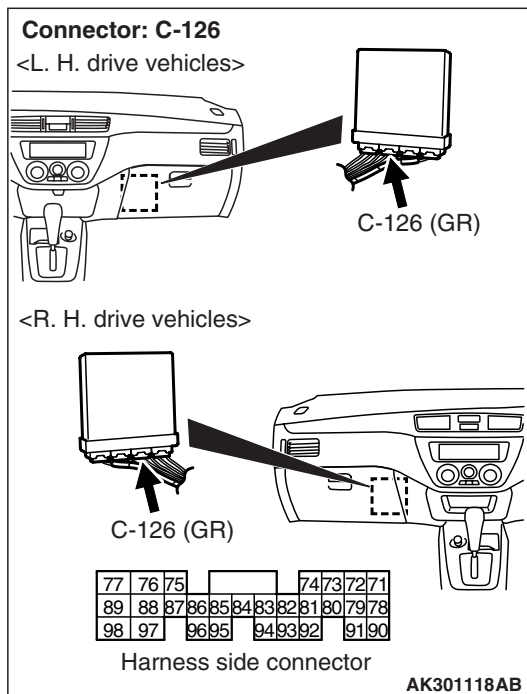

**STEP 22. Connector check: C-129 engine-ECU
<M/T> connector or C-126 engine-A/T-ECU <A/T>
connector**

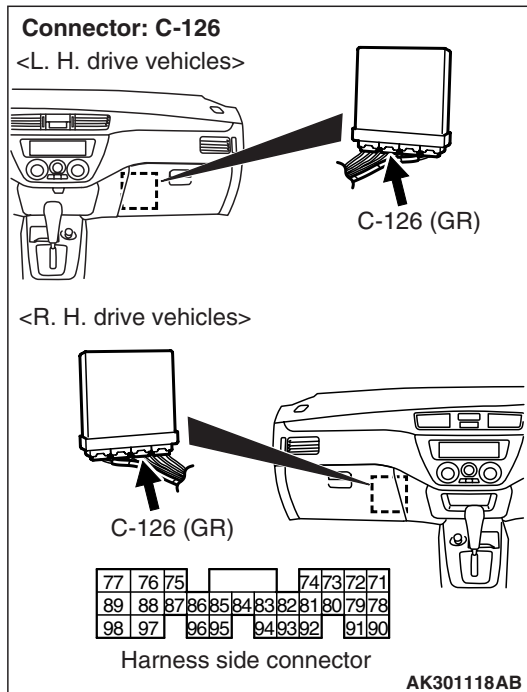
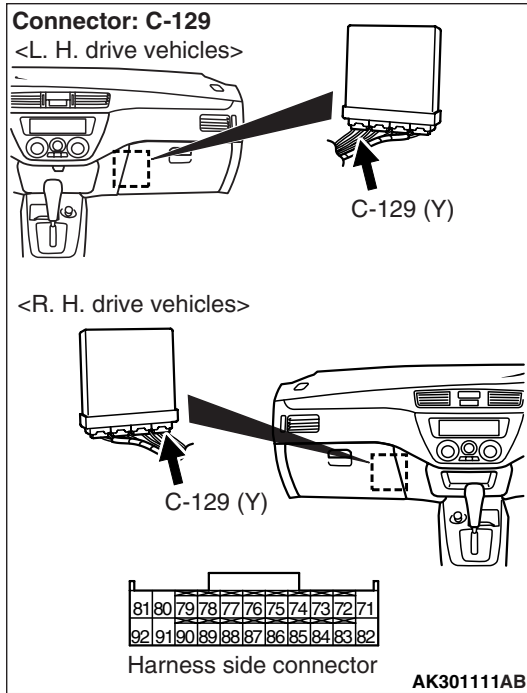

Q: Is the check result normal?

YES : Go to Step 9 .

NO : Repair or replace.

Code No. P0125: Feedback system monitor**OPERATION**

- Refer to P0201 injector circuit [P.13A-115](#).
- Refer to P0202 injector circuit [P.13A-121](#).
- Refer to P0203 injector circuit [P.13A-127](#).
- Refer to P0204 injector circuit [P.13A-133](#).
- Refer to P0130 Oxygen sensor (front) circuit [P.13A-74](#).

FUNCTION

- The engine-ECU<M/T> or engine-A/T-ECU<A/T> effects air-fuel ratio feedback control in accordance with the signals from the oxygen sensor (front).
- If the oxygen sensor (front) has deteriorated, corrections will be made by the oxygen sensor (rear).
- Diagnosis code P0125 becomes stored in memory if a failure is detected in the above air-fuel ratio feedback control system.

TROUBLE JUDGMENT**Check Conditions**

- The engine coolant temperature is approximately 82° C or more.
- Within the range of air-fuel ratio feedback operation.
- Not in slowing down operation.

Judgment Criterion

- The oxygen sensor output voltage is not deviated from 0.5 V for 30 seconds.

PROBABLE CAUSE

- Failed oxygen sensor (front)
- Harness damage in oxygen sensor (front) circuit or loose connector contact
- Failed oxygen sensor (rear)

NOTE: When the oxygen sensor (front) begins to deteriorate, the oxygen sensor output voltage will deviate from the voltage when the sensor was new (normally 0.5 volt at stoichiometric ratio). This deviation will be corrected by the oxygen sensor (rear). If the oxygen sensor (rear) responds poorly because it has deteriorated, it will improperly correct the oxygen sensor (front). Thus, even when closed loop control is being effected, the fluctuation of the oxygen sensor (front) output voltage decreases, without intersecting with 0.5 volt. As a result, there is a possibility of diagnosis code P0125 becoming registered.

- Failed fuel system
- Failed exhaust system
- Failed engine-ECU <M/T>
- Failed engine-A/T-ECU <A/T>

DIAGNOSIS PROCEDURE**STEP 1. M.U.T.-II/III diagnosis code**

- Q: Is any other diagnosis code than P0125 output?**
YES : Inspection chart for diagnosis code (Refer to [P.13A-17](#)).
NO : Go to Step 2 .

STEP 2. M.U.T.-II/III data list

- Refer to data list reference table [P.13A-376](#).
 - Item 21: Engine coolant temperature sensor
 - Item 32: Manifold absolute pressure sensor
 - Item 59: Oxygen sensor (rear)

Q: Are the check results normal?

- YES :** Go to Step 3 .
NO : Perform the diagnosis code classified check procedure for the sensor that has shown an abnormal data value (Refer to Inspection Chart for diagnosis codes [P.13A-17](#)).

STEP 3. Check for intake of air from intake hose and inlet manifold.**Q: Is the check result normal?**

- YES :** Go to Step 4 .
NO : Repair.

STEP 4. Check for leakage of exhaust emission from exhaust manifold.**Q: Is the check result normal?**

- YES :** Go to Step 5 .
NO : Repair.

STEP 5. Check throttle body (throttle valve portion) for contamination.**Q: Is the check result normal?**

- YES :** Go to Step 6 .
NO : Clean throttle body (throttle valve portion) (Refer to [P.13A-398](#)).

STEP 6. Connector check: B-21 oxygen sensor (front) connector, C-129 engine-ECU <M/T> connector or C-126 engine-A/T-ECU <A/T> connector

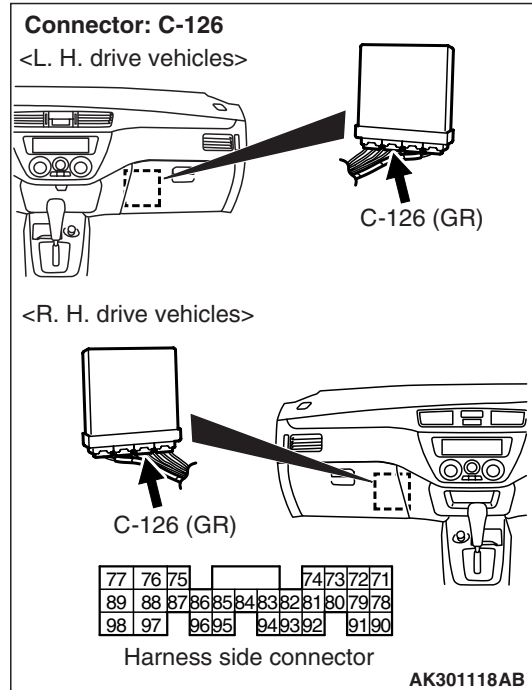
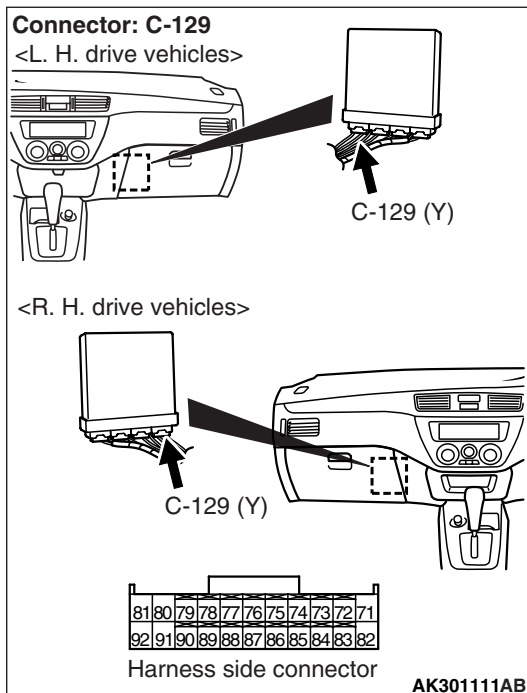
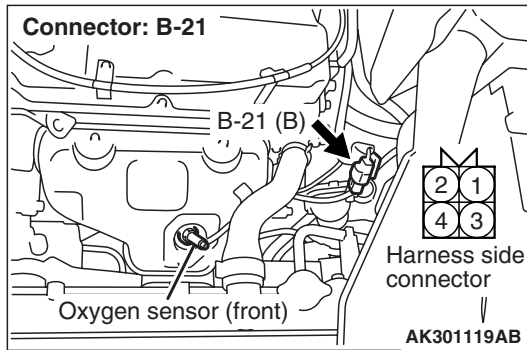

- Q: Is the check result normal?**
YES : Go to Step 7 .
NO : Repair or replace.

STEP 7. Check oxygen sensor (front) itself.

- Check oxygen sensor (front) itself (Refer to [P.13A-406](#)).

- Q: Is the check result normal?**
YES : Go to Step 8 .
NO : Replace oxygen sensor (front).

STEP 8. Check harness between B-21 oxygen sensor (front) connector and C-129 engine-ECU <M/T> connector or C-126 engine-A/T-ECU <A/T> connector.

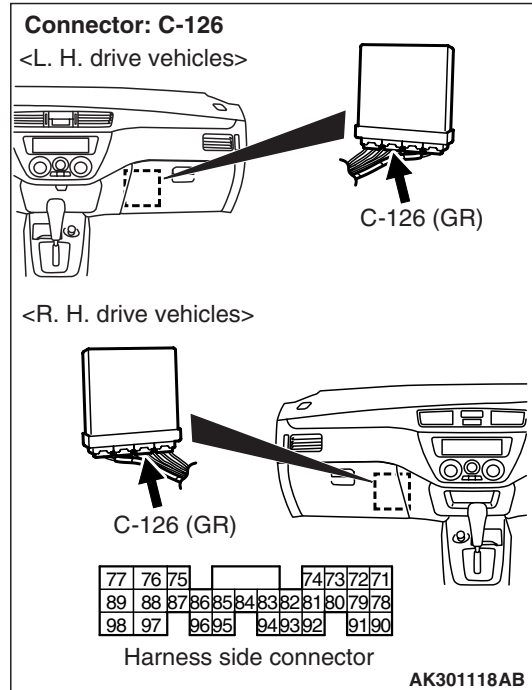
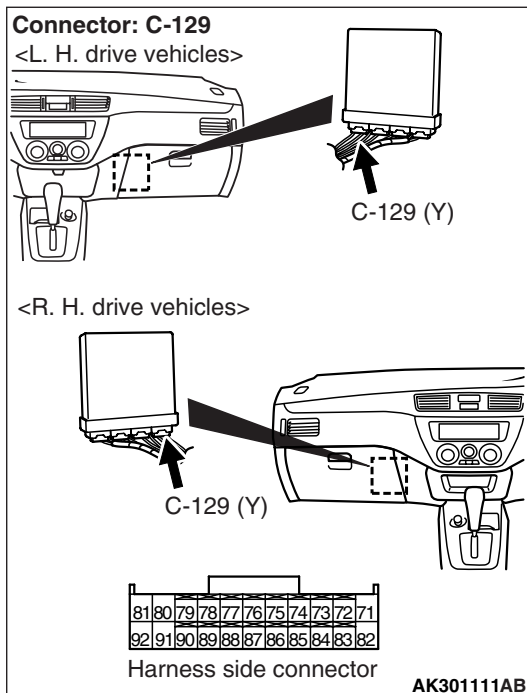
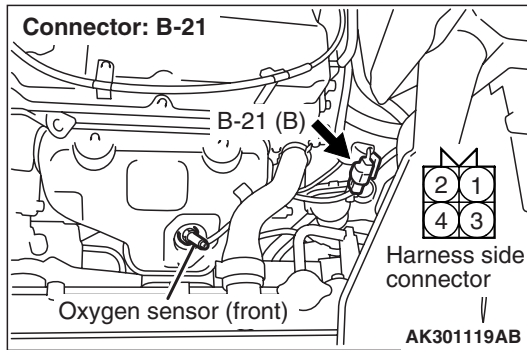

- Check output line for damage.

Q: Is the check result normal?

YES : Go to Step 9 .

NO : Repair.

STEP 9. Connector check: Injector connector

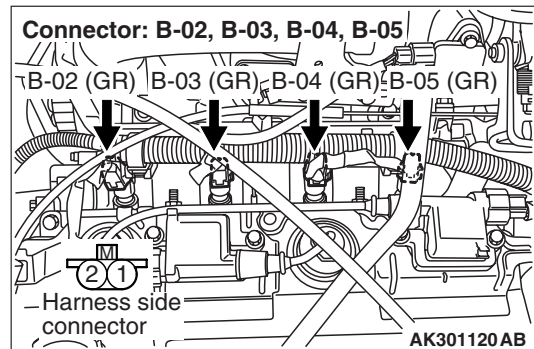

- B-02 (No.1 injector connector)
- B-03 (No.2 injector connector)
- B-04 (No.3 injector connector)
- B-05 (No.4 injector connector)

Q: Are the check results normal?

YES : Go to Step 10 .

NO : Repair.

STEP 10. Check injector itself.

- Check Injector itself (Refer to P.13A-407).

Q: Is the check result normal?

YES : Go to Step 11 .

NO : Replace injector.

STEP 11. Connector check: B-16X engine control relay connector and C-123 engine-ECU <M/T> connector or C-122 engine-A/T-ECU <A/T> connector.

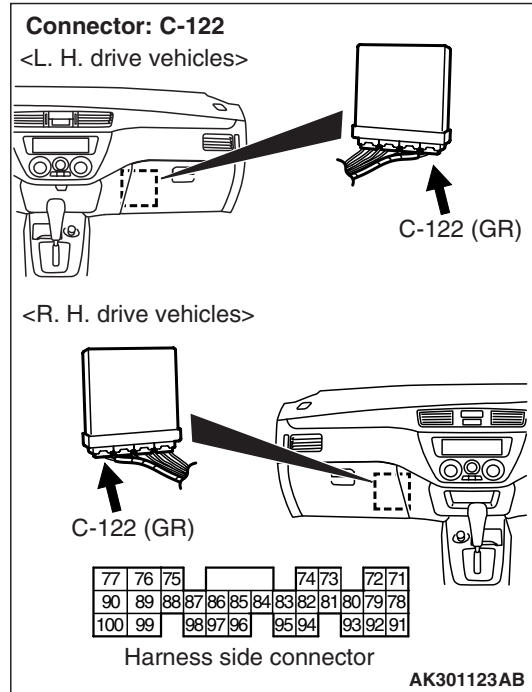
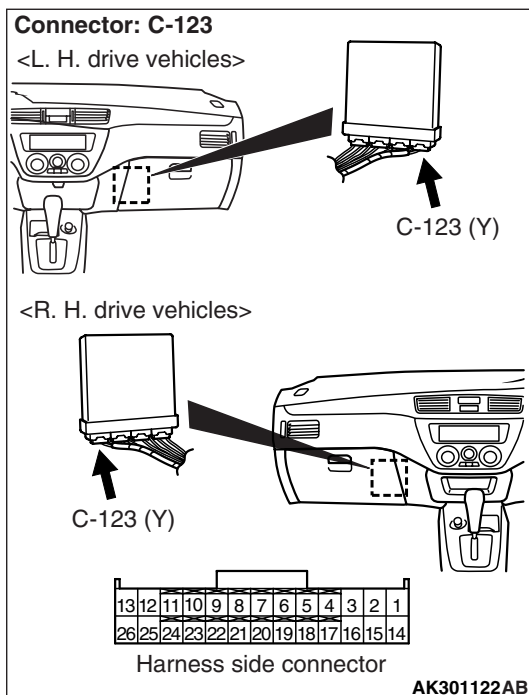
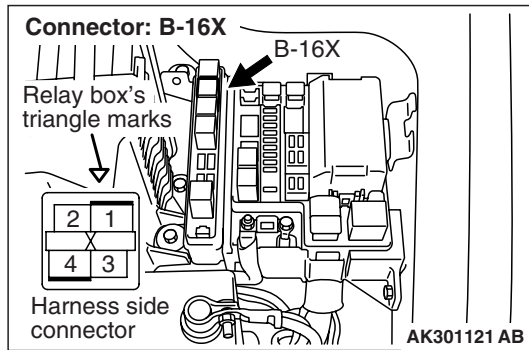

Q: Is the check result normal?
YES : Go to Step 12 .
NO : Repair or replace.

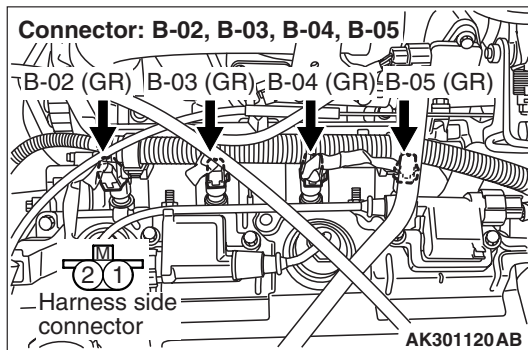
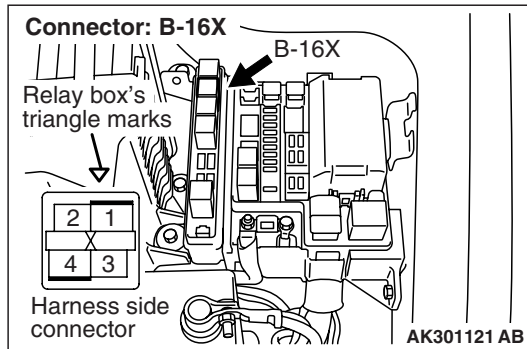
STEP 12. Check harness between B-16X engine control relay connector and injector connector.

- Check harness between B-16X (terminal No. 4) engine control relay connector and B-02 (terminal No. 1) No. 1 injector connector.
- Check harness between B-16X (terminal No. 4) engine control relay connector and B-03 (terminal No. 1) No. 2 injector connector.
- Check harness between B-16X (terminal No. 4) engine control relay connector and B-04 (terminal No. 1) No. 3 injector connector.
- Check harness between B-16X (terminal No. 4) engine control relay connector and B-05 (terminal No. 1) No. 4 injector connector.
 - Check power supply line for damage.

Q: Are the check results normal?

YES : Go to Step 13 .

NO : Repair.

STEP 13. Check harness between injector connector and C-123 engine-ECU<M/T> connector or C-122 engine-A/T-ECU<A/T> connector.

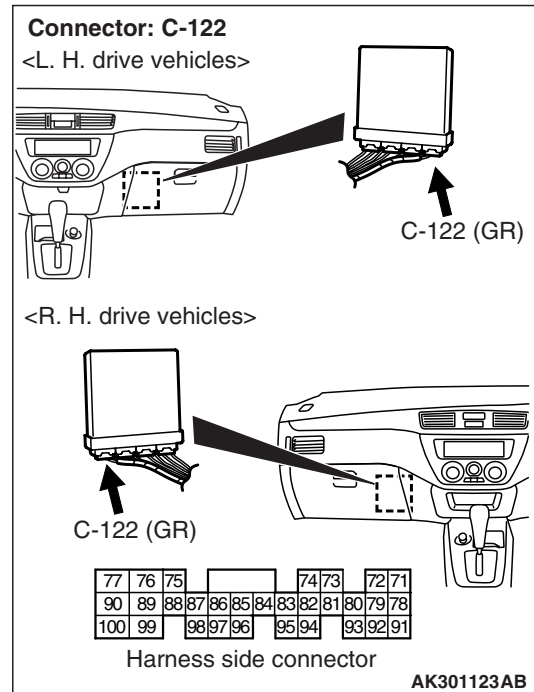
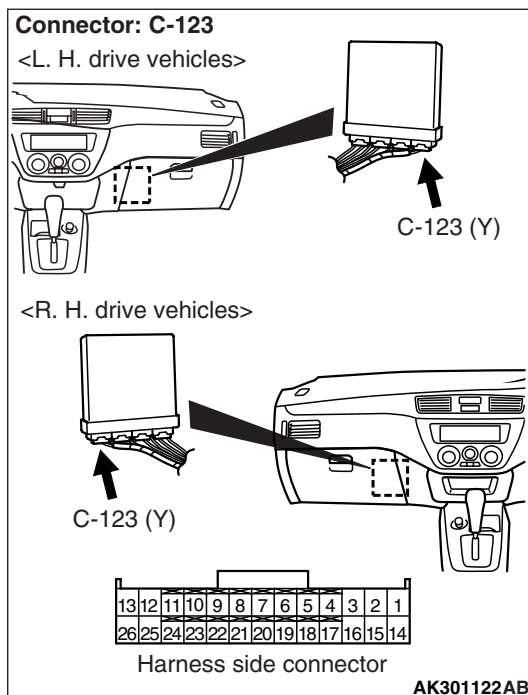
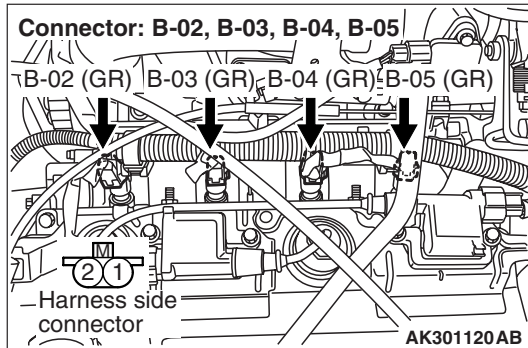

- Check harness between B-02 (terminal No. 2) No. 1 injector connector and C-123 (terminal No. 1) engine-ECU <M/T> connector or C-122 (terminal No. 1) engine-A/T-ECU <A/T> connector.
- Check harness between B-03 (terminal No. 2) No. 2 injector connector and C-123 (terminal No. 14) engine-ECU <M/T> connector or C-122 (terminal No. 9) engine-A/T-ECU <A/T> connector.
- Check harness between B-04 (terminal No. 2) No. 3 injector connector and C-123 (terminal No. 2) engine-ECU <M/T> connector or C-122 (terminal No. 24) engine-A/T-ECU <A/T> connector.
- Check harness between B-05 (terminal No. 2) No. 4 injector connector and C-123 (terminal No. 15) engine-ECU <M/T> connector or C-122 (terminal No. 2) engine-A/T-ECU <A/T> connector.

Q: Are the check results normal?

YES : Go to Step 14 .

NO : Repair.

STEP 14. Fuel pressure measurement.

- Fuel pressure measurement (Refer to [P.13A-399](#)).

Q: Is the check result normal?

YES : Replace engine-ECU <M/T> or engine-A/T-ECU <A/T>.

NO : Repair.

Code No. P0130: Oxygen Sensor (front) System <sensor 1>

Oxygen sensor (front) circuit

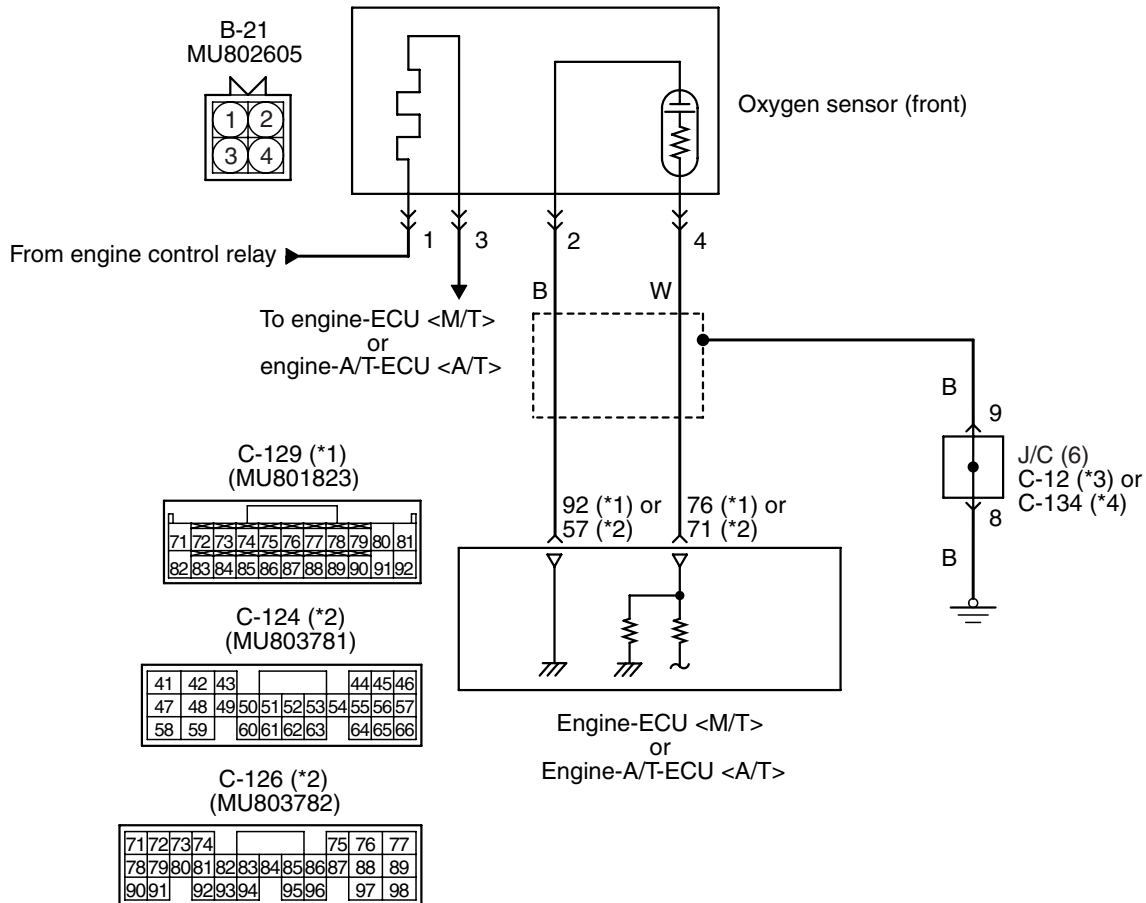

NOTE

- *1: M/T
- *2: A/T
- *3: L.H. drive vehicles
- *4: R.H. drive vehicles

Wire colour code

B: Black LG: Light green G: Green L: Blue W: White Y: Yellow SB: Sky blue BR: Brown O: Orange GR: Gray R: Red P: Pink V: Violet

AK401348AB

OPERATION

- The sensor signal is inputted to the engine-ECU (terminal No. 76) <M/T> or engine-A/T-ECU (terminal No. 71) <A/T> from the oxygen sensor output terminal (terminal No. 4).
- The oxygen sensor (terminal No. 2) is earthed with engine-ECU (terminal No. 92) <M/T> or engine-A/T-ECU (terminal No. 57) <A/T>.

FUNCTION

- The oxygen sensor converts the concentration of oxygen in the exhaust emission into a voltage and inputs the signal to the engine-ECU <M/T> or engine-A/T-ECU <A/T>.

- When the air-fuel ratio is richer than the theoretical air-fuel ratio, the oxygen sensor outputs a voltage of about 1 V. When it is leaner than the theoretical air-fuel ratio, it outputs a voltage of about 0 V.
- In response to the signal, the engine-ECU <M/T> or engine-A/T-ECU <A/T> controls the fuel injection amount so that the air-fuel ratio can be equivalent to the theoretical air-fuel ratio.

TROUBLE JUDGMENT

Check Conditions

- Above 3 minutes later after the engine has started up.
- The engine coolant temperature is approximately 82° C or more.
- The engine speed is 1,200 r/min or more.
- The volumetric efficiency 25% or more.
- The monitoring time is 5 seconds.

Judgment Criterion

- When the oxygen sensor (front) output voltage is 0.2 V or less and a power voltage of 5 V is applied to the oxygen sensor (front) in the engine-ECU <M/T> or engine-A/T-ECU <A/T>, the sensor output voltage is 4.5 V or more.

Check Condition

- The engine speed is 3,000 r/min or less.
- During the air-fuel ratio feedback control

Judgment Criteria

- When the oxygen sensor (front) output frequency is 6 or less for 10 seconds on the average.

PROBABLE CAUSE

- Failed oxygen sensor
- Open/short circuit in oxygen sensor (front) circuit or loose connector contact
- Failed engine-ECU <M/T>
- Failed engine-A/T-ECU <A/T>

DIAGNOSIS PROCEDURE

STEP 1. M.U.T.-II/III data list

- Refer to data list reference table [P.13A-376](#).
 - Item 11: Oxygen sensor (front)

Q: Is the check result normal?

YES : Intermittent malfunction (Refer to GROUP 00 –How to Use Troubleshooting/Inspection Service Points [P.00-5](#)).

NO : Go to Step 2 .

STEP 2. Connector check: B-21 oxygen sensor (front) connector

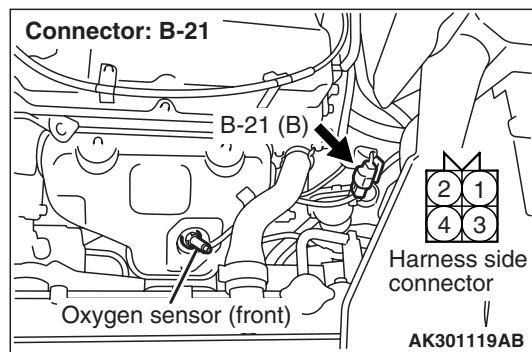

Q: Is the check result normal?

YES : Go to Step 3 .

NO : Repair or replace.

STEP 3. Perform resistance measurement at B-21 oxygen sensor (front) connector.

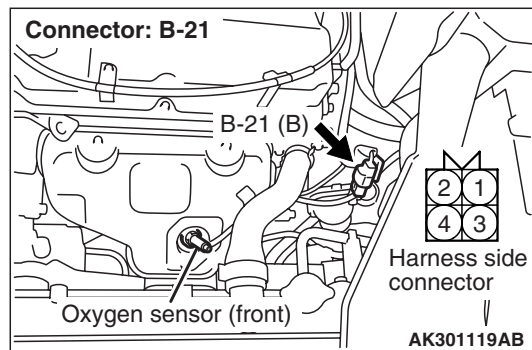

- Disconnect connector, and measure at harness side.
- Resistance between terminal No. 2 and earth.

OK: Continuity (2 Ω or less)

Q: Is the check result normal?

YES : Go to Step 7 .

NO : Go to Step 4 .

STEP 4. Connector check: C-129 engine-ECU <M/T> connector or C-124 engine-A/T-ECU <A/T> connector

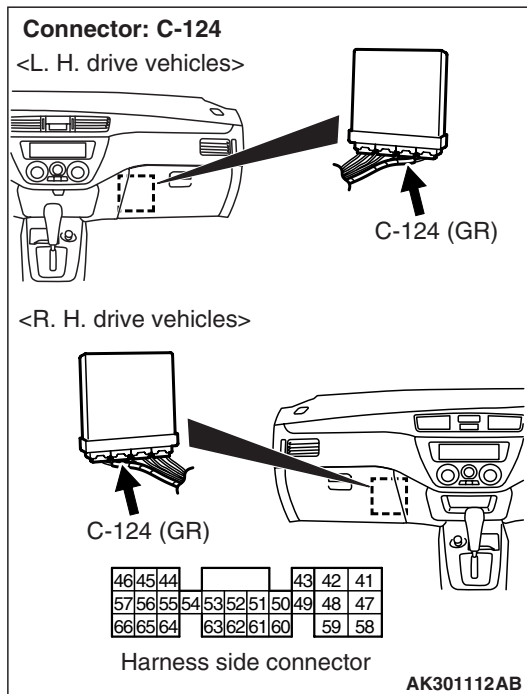
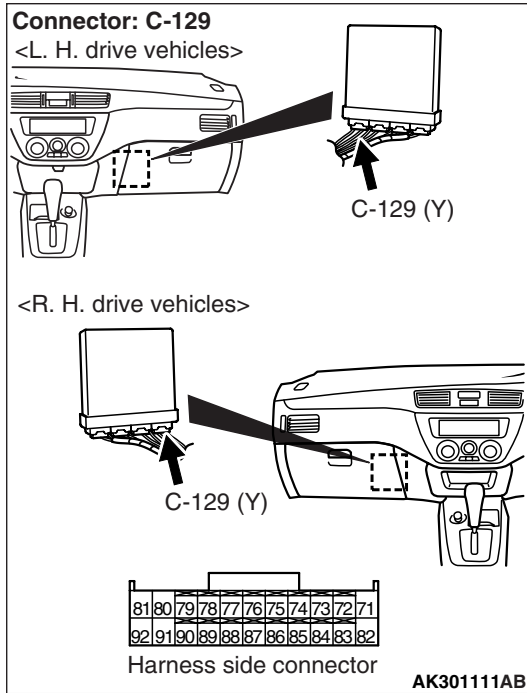

Q: Is the check result normal?

YES : Go to Step 5 .

NO : Repair or replace.

STEP 5. Check harness between B-21 (terminal No. 2) oxygen sensor (front) connector and C-129 (terminal No. 92) engine-ECU <M/T> connector or C-124 (terminal No. 57) engine-A/T-ECU <A/T> connector.

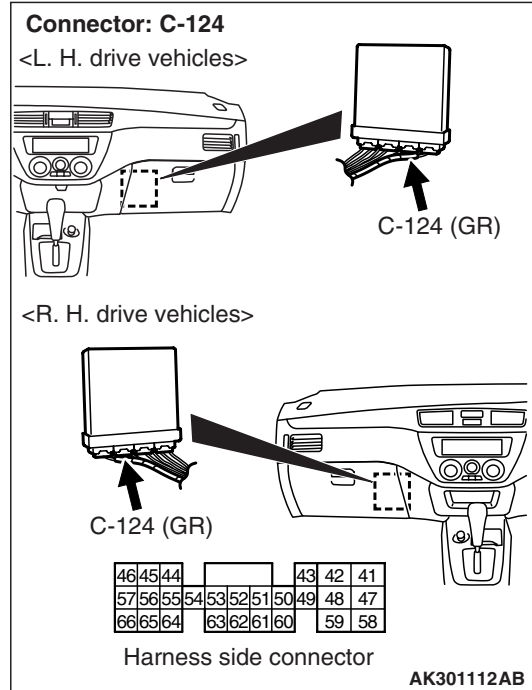
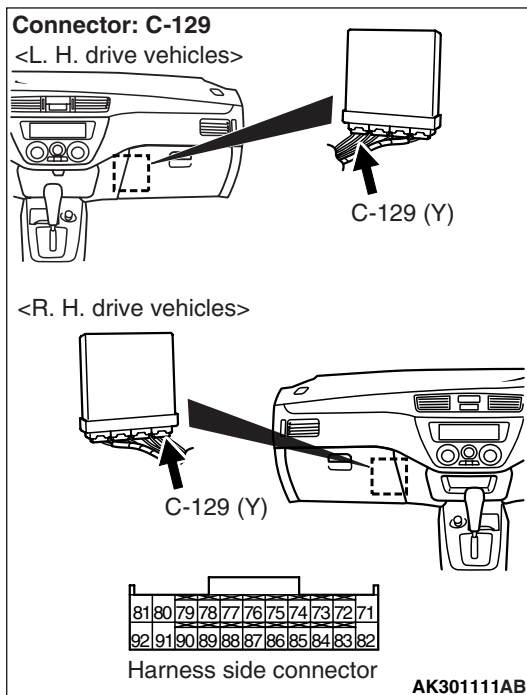
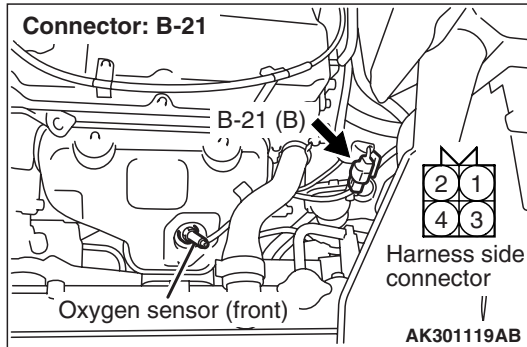

- Check earthing line for open circuit and damage.

Q: Is the check result normal?

YES : Go to Step 6 .

NO : Repair.

STEP 6. M.U.T.-II/III data list

- Refer to data list reference table [P.13A-376](#).
 - Item 11: Oxygen sensor (front)

Q: Is the check result normal?

YES : Intermittent malfunction (Refer to GROUP 00 –How to Use Troubleshooting/Inspection Service Points [P.00-5](#)).

NO : Replace engine-ECU <M/T> or engine-A/T-ECU <A/T>.

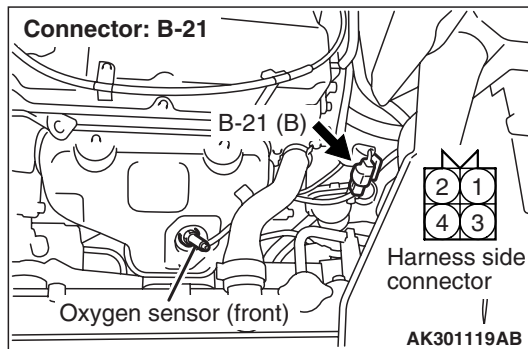
STEP 7. Perform voltage measurement at B-21 oxygen sensor (front) connector.

- Use special tool test harness (MD998464) to connect connector, and measure at pick-up harness.
- Engine: After warm-up
- Ignition switch: ON
- Voltage between terminal No. 2 and earth.

OK: 0.5 V or less

Q: Is the check result normal?

YES : Go to Step 9 .

NO : Go to Step 8 .

STEP 8. Connector check: C-129 engine-ECU <M/T> connector or C-124 engine-A/T-ECU <A/T> connector

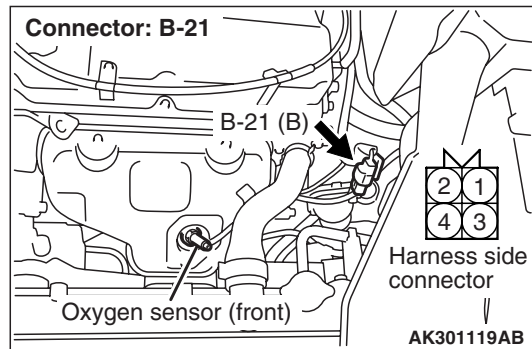
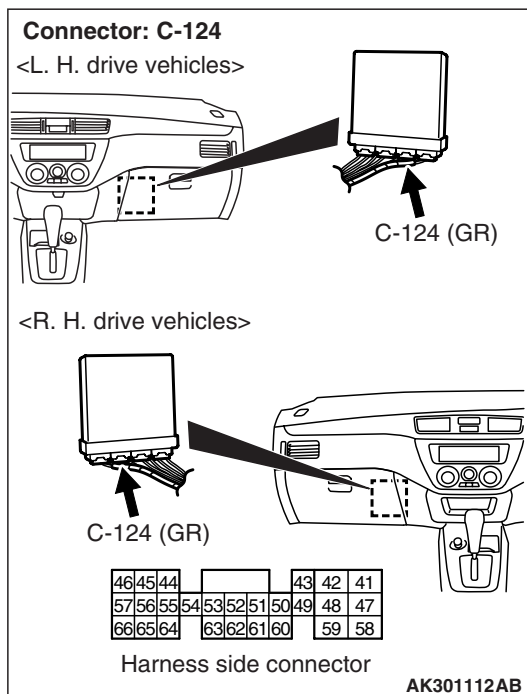
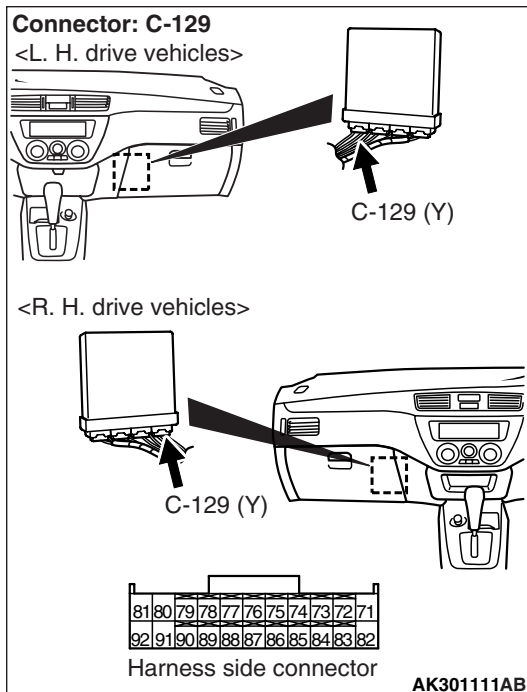

Q: Is the check result normal?

YES : Check and repair harness between B-21 (terminal No. 2) oxygen sensor (front) connector and C-129 (terminal No. 92) engine-ECU <M/T> connector or C-124 (terminal No. 57) engine-A/T-ECU <A/T> connector.

- Check earthing line for damage.

NO : Repair or replace.

STEP 9. Perform voltage measurement at B-21 oxygen sensor (front) connector.

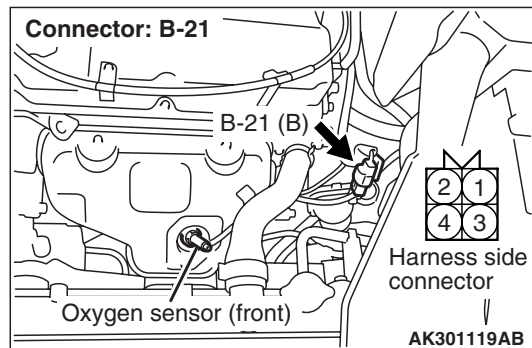

- Use special tool test harness (MD998464) to connect connector, and measure at pick-up harness.
- Engine: After warm-up
- Voltage between terminal No. 4 and earth.

OK:

600 –1,000 mV when 200 mV or lower abrupt racing is done a few seconds after abrupt deceleration from 4,000 r/min.

Q: Is the check result normal?

YES : Go to Step 12 .

NO : Go to Step 10 .

STEP 10. Check oxygen sensor (front) itself

- Check oxygen sensor (front) itself (Refer to P.13A-406).

Q: Is the check result normal?

YES : Go to Step 11 .

NO : Replace oxygen (front) sensor.

STEP 11. Connector check: C-129 engine-ECU <M/T> connector or C-126 engine-A/T-ECU <A/T> connector

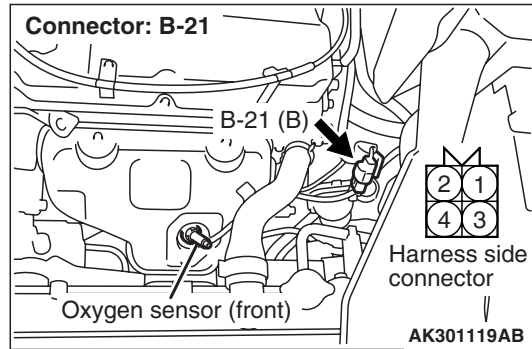
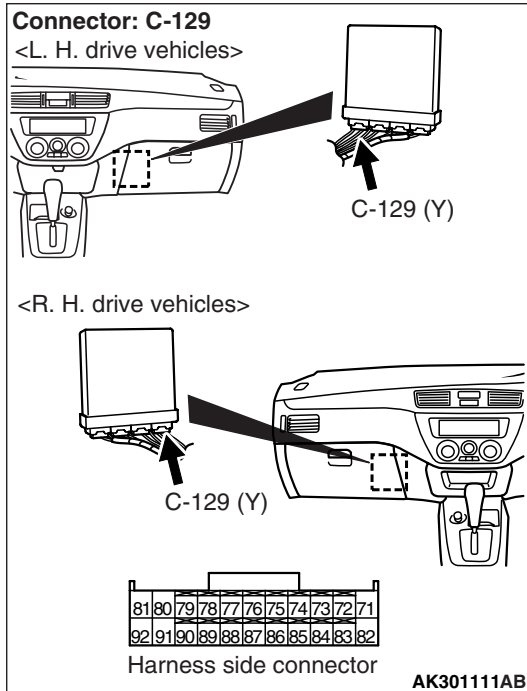

Q: Is the check result normal?

YES : Check and repair harness between B-21 (terminal No. 4) oxygen sensor (front) connector and C-129 (terminal No. 76) engine-ECU <M/T> connector or C-126 (terminal No. 71) engine-A/T-ECU <A/T> connector.

- Check output line for damage.

NO : Repair or replace.

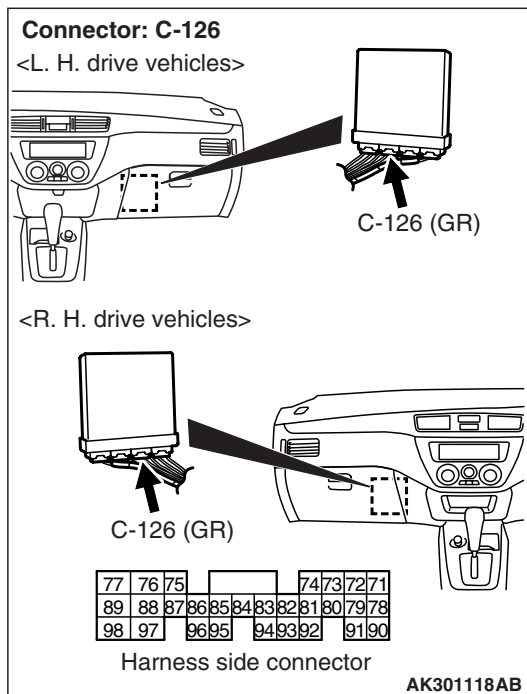

STEP 12. Perform voltage measurement at C-129 engine-ECU <M/T> connector or C-126 engine-A/T-ECU <A/T> connector.

OK:
600 – 1,000 mV when 200 mV or lower abrupt racing is done a few seconds after abrupt deceleration from 4,000 r/min.

Q: Is the check result normal?
YES : Go to Step 14 .
NO : Go to Step 13 .

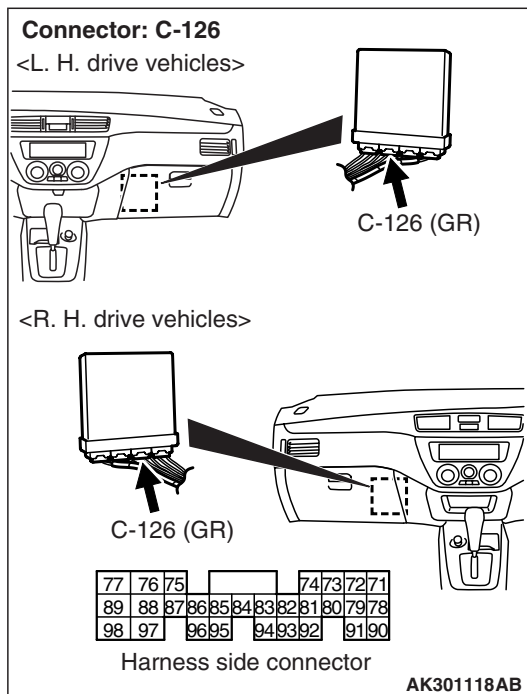
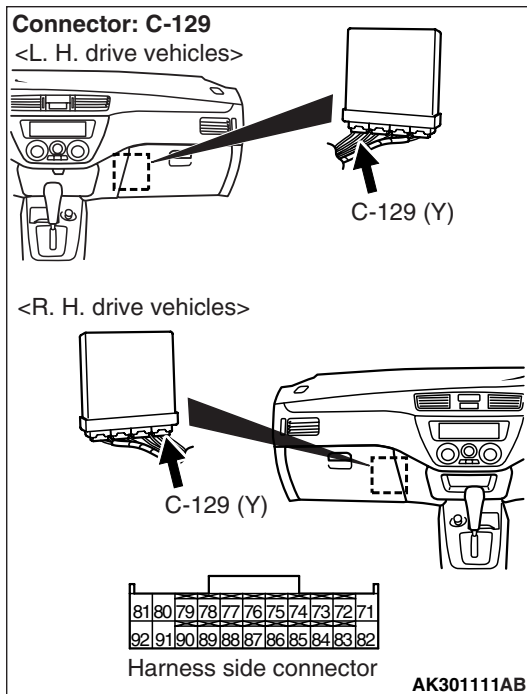

- Measure engine-ECU <M/T> or engine-A/T-ECU <A/T> terminal voltage.
- Transmission: Neutral <M/T> or P range <A/T>
- Engine: After warm-up
- Voltage between terminal No. 76 <M/T> or terminal No. 71 <A/T> and earth.

STEP 13. Connector check: C-129 engine-ECU <M/T> connector or C-126 engine-A/T-ECU <A/T> connector

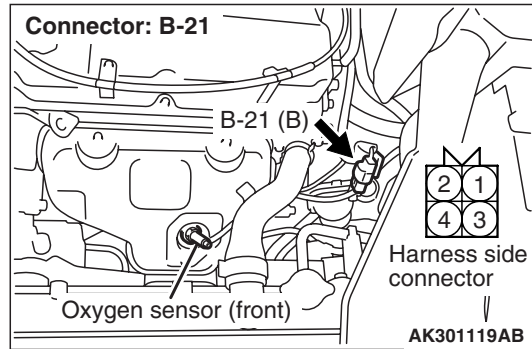
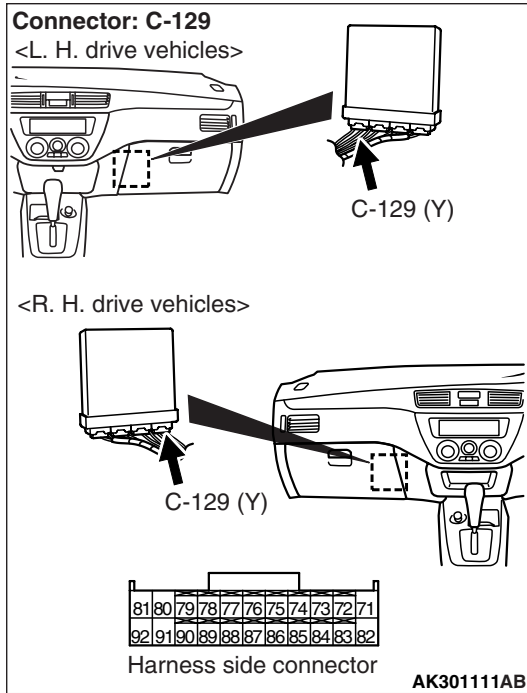

Q: Is the check result normal?

YES : Check and repair harness between B-21 (terminal No. 4) oxygen sensor (front) connector and C-129 (terminal No. 76) engine-ECU <M/T> connector or C-126 (terminal No. 71) engine-A/T-ECU <A/T> connector.

- Check output line for open circuit.

NO : Repair or replace.

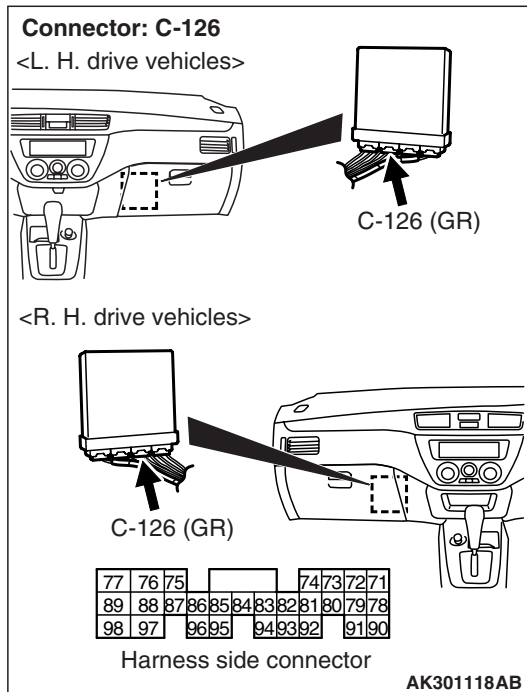

**STEP 14. Connector check: C-129 engine-ECU
<M/T> connector or C-126 engine-A/T-ECU <A/T>
connector**

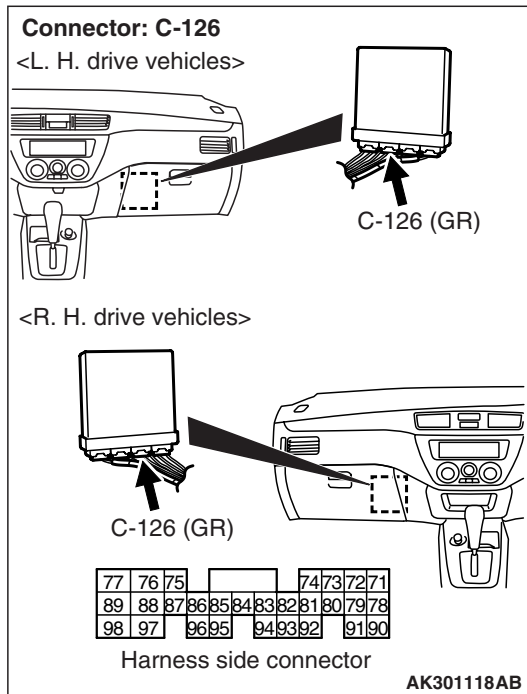
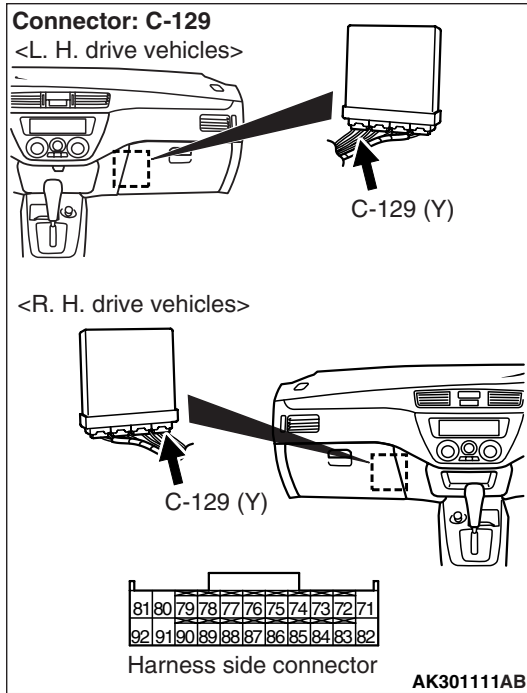

Q: Is the check result normal?

YES : Go to Step 6 .

NO : Repair or replace.

Code No. P0135: Oxygen Sensor (front) Heater System <sensor 1>

Oxygen sensor (front) heater circuit

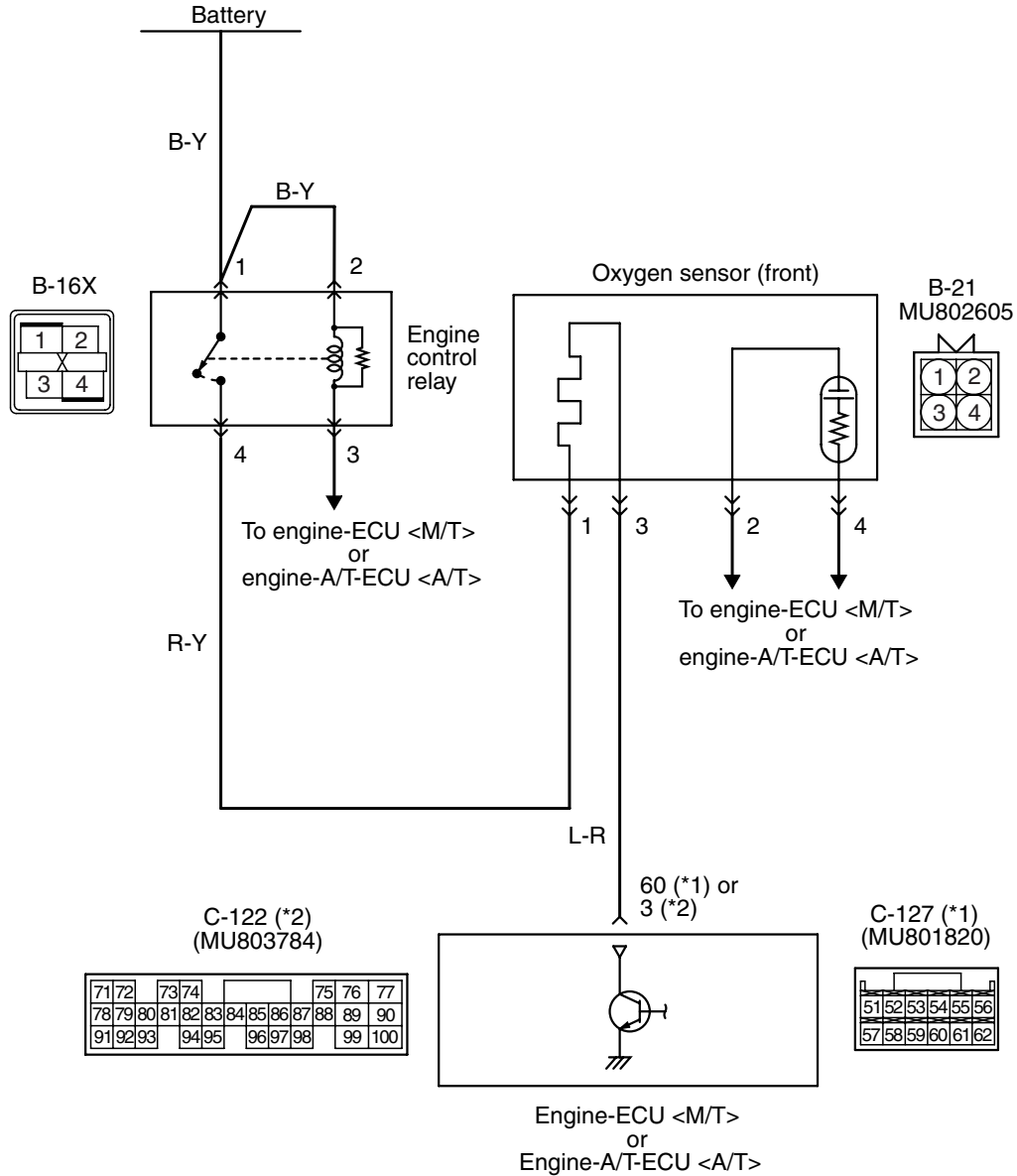

NOTE
*1: M/T
*2: A/T

Wire colour code

B: Black LG: Light green G: Green L: Blue W: White Y: Yellow SB: Sky blue BR: Brown O: Orange GR: Gray
R: Red P: Pink V: Violet

OPERATION

- Power is supplied to the heater power terminal (terminal No. 1) of the oxygen sensor (front) connector from the engine control relay (terminal No. 4).
- The heater (terminal No. 3) of the oxygen sensor (front) connector is controlled by the power transistor in the engine-ECU (terminal No. 60) <M/T> or engine-A/T-ECU (terminal No. 3) <A/T>.

FUNCTION

- The power supply to the oxygen sensor heater (front) is controlled by the ON/OFF control of the power transistor in the engine-ECU <M/T> or engine-A/T-ECU <A/T>.
- Heating the oxygen sensor heater (front) enables the oxygen sensor to provide good response even when the exhaust emission temperature is low.

TROUBLE JUDGMENT

Check Conditions

- The engine coolant temperature is 20° C or higher.
- The oxygen sensor heater (front) is in "ON" position.
- The engine speed is 50 r/min or more.
- The battery voltage is 11 – 16 V.

Judgment Criterion

- The heater current of oxygen sensor heater (front) is below 0.2 A or above 3.5 A for 1 second.

PROBABLE CAUSE

- Failed oxygen sensor heater (front)
- Open/short circuit in oxygen sensor heater (front) circuit or loose connector contact
- Failed engine-ECU <M/T>
- Failed engine-A/T-ECU <A/T>

DIAGNOSIS PROCEDURE

STEP 1. Connector check: B-21 oxygen sensor (front) connector

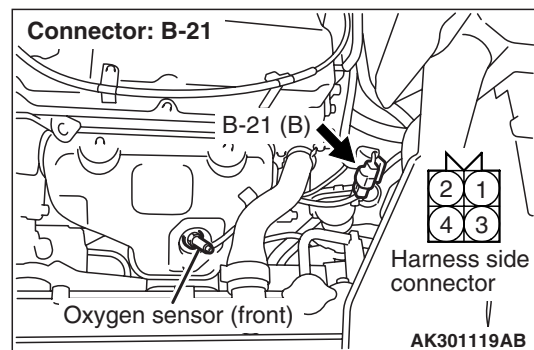

Q: Is the check result normal?

YES : Go to Step 2 .

NO : Repair or replace.

STEP 2. Perform resistance measurement at B-21 oxygen sensor (front) connector.

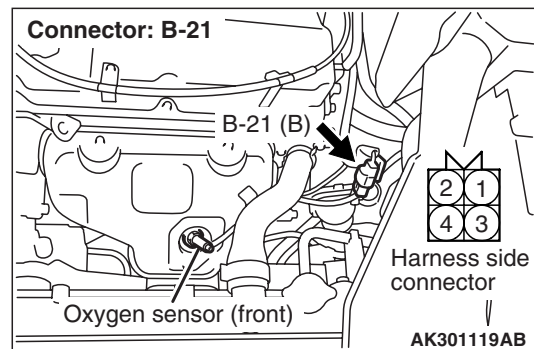

- Disconnect connector, and measure at sensor side.
- Resistance between terminal No. 1 and No. 3.

OK: 4.5 – 8.0 Ω

Q: Is the check result normal?

YES : Go to Step 3 .

NO : Replace oxygen sensor (front).

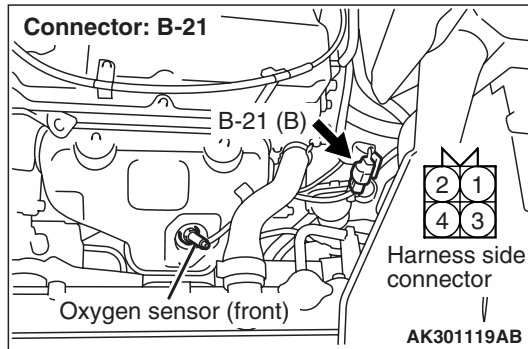
STEP 3. Perform voltage measurement at B-21 oxygen sensor (front) connector.

- Disconnect connector, and measure at harness side.
- Ignition switch: ON
- Voltage between terminal No. 1 and earth.

OK: System voltage

Q: Is the check result normal?

YES : Go to Step 5 .

NO : Go to Step 4 .

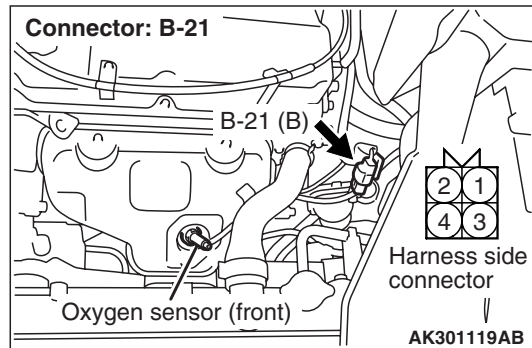
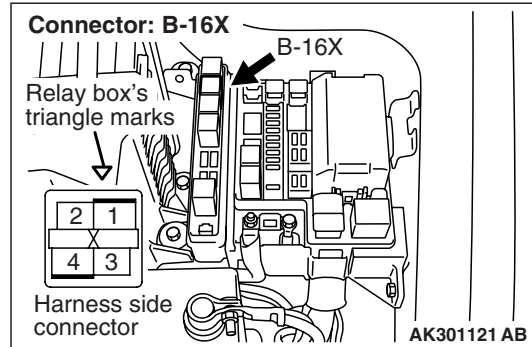
STEP 4. Connector check: B-16X engine control relay connector

Q: Is the check result normal?

YES : Check and repair harness between B-21 (terminal No. 1) oxygen sensor connector and B-16X (terminal No. 4) engine control relay connector.

- Check power supply line for open/short circuit.

NO : Repair or replace.

STEP 5. Perform voltage measurement at C-127 engine-ECU <M/T> connector or C-122 engine-A/T-ECU <A/T> connector.

STEP 6. Connector check: C-127 engine-ECU <M/T> connector or C-122 engine-A/T-ECU <A/T> connector

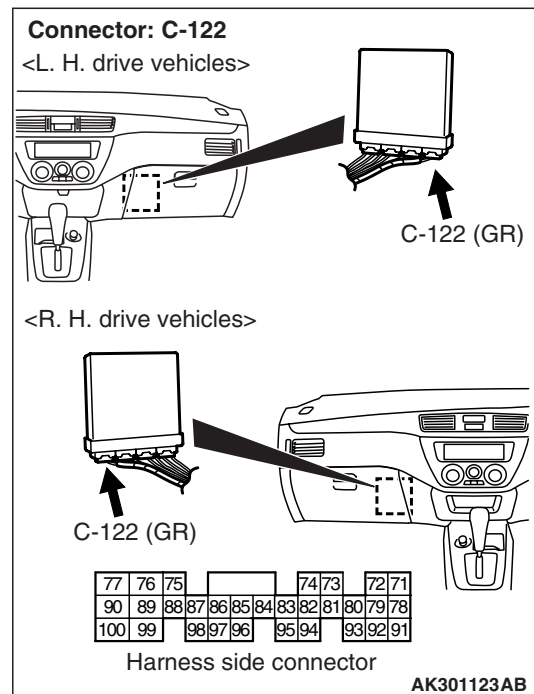
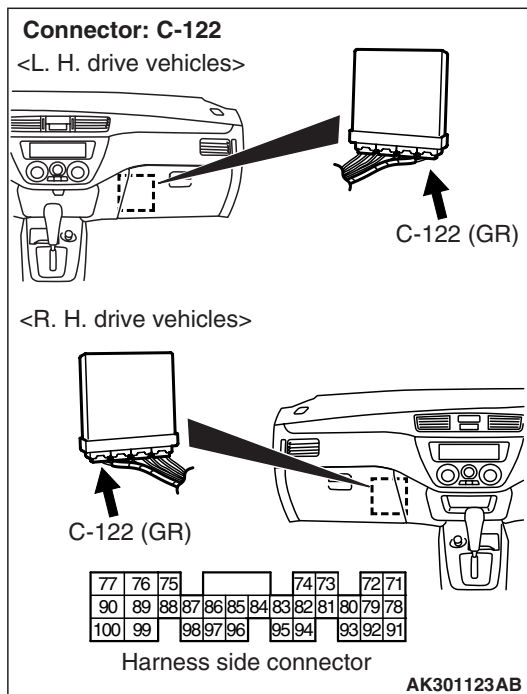
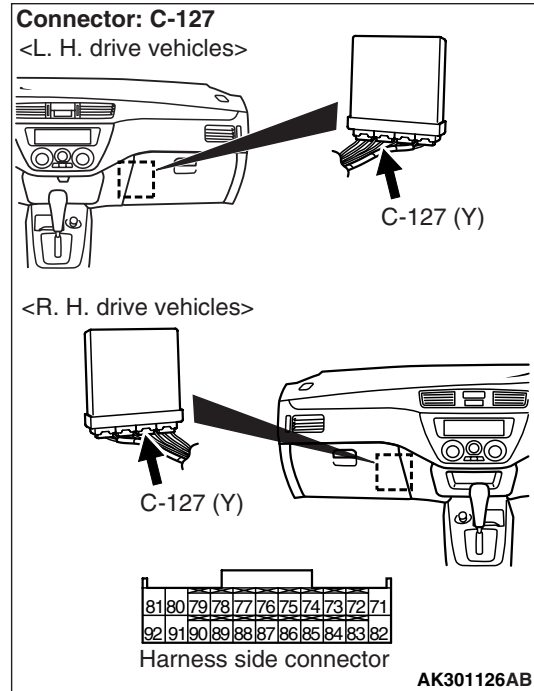
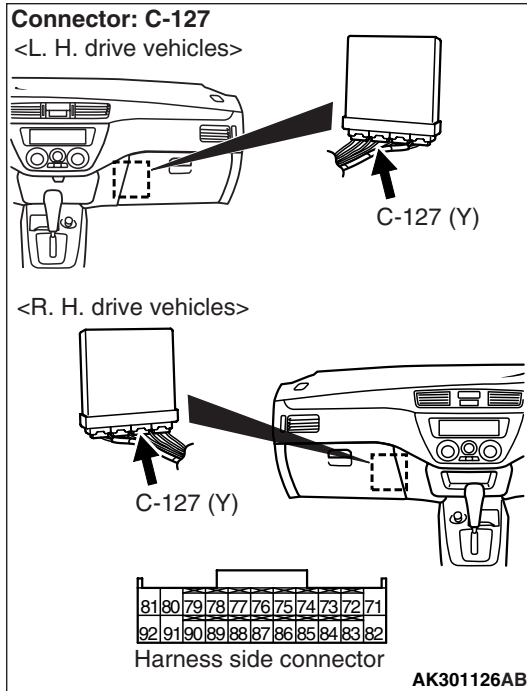

- Measure engine-ECU <M/T> or engine-A/T-ECU <A/T> terminal voltage.
- Ignition switch: ON
- Voltage between terminal No. 60 <M/T> or terminal No. 3 <A/T> and earth.

OK: System voltage

Q: Is the check result normal?

YES : Go to Step 8 .

NO : Go to Step 6 .

Q: Is the check result normal?

YES : Go to Step 7 .

NO : Repair or replace.

STEP 7. Check harness between B-21 (terminal No. 3) oxygen sensor (front) connector and C-127 (terminal No. 60) engine-ECU <M/T> connector or C-122 (terminal No. 3) engine-A/T-ECU <A/T> connector.

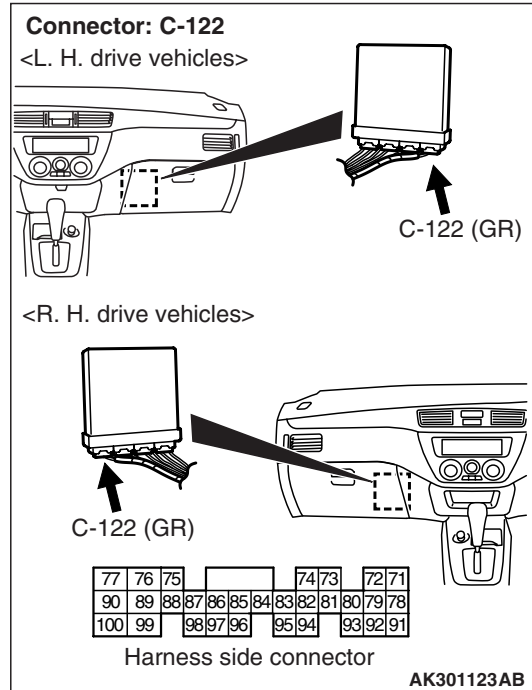
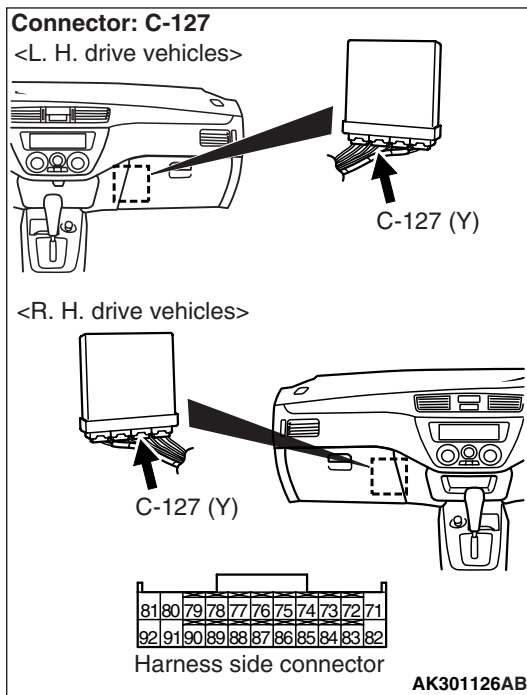
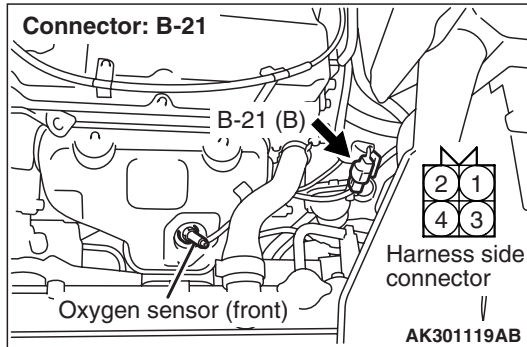

- Check earthing line for open/short circuit.

Q: Is the check result normal?

YES : Replace engine-ECU <M/T> or engine-A/T-ECU <A/T>.

NO : Repair.

STEP 8. Connector check: C-127 engine-ECU <M/T> connector or C-122 engine-A/T-ECU <A/T> connector

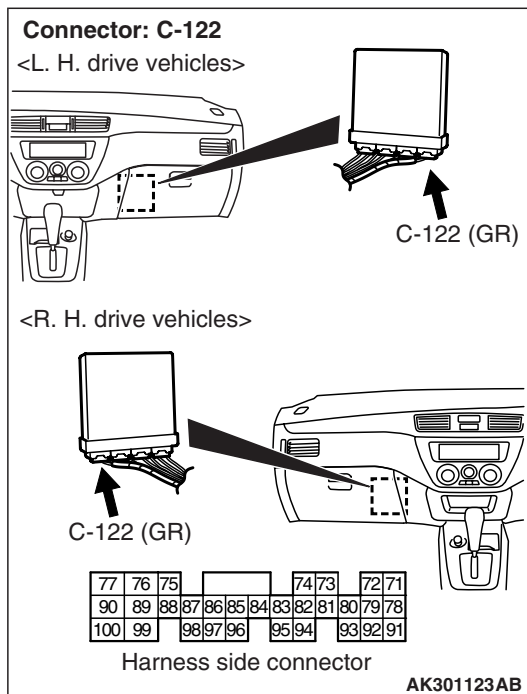
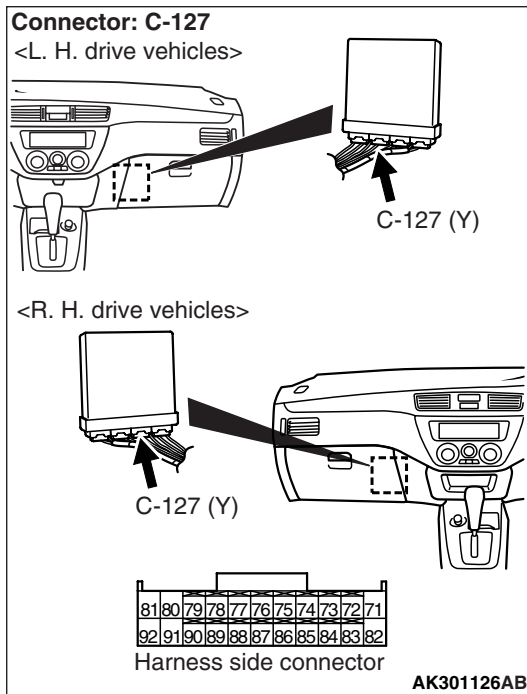

STEP 9. Check harness between B-21 (terminal No. 1) oxygen sensor (front) connector and B-16X (terminal No. 4) engine control relay connector.

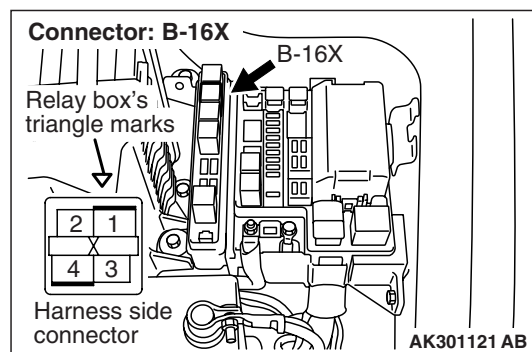
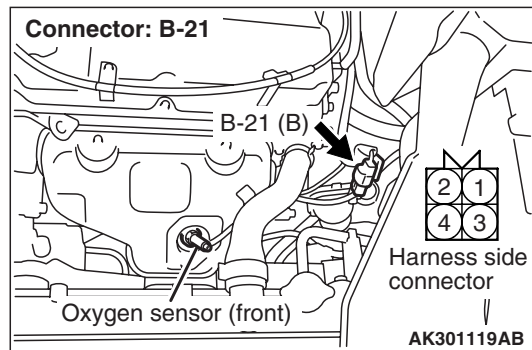

- Check power supply line for damage.

Q: Is the check result normal?

YES : Go to Step 10 .

NO : Repair.

Q: Is the check result normal?

YES : Go to Step 9 .

NO : Repair or replace.

STEP 10. Check harness between B-21 (terminal No. 3) oxygen sensor (front) connector and C-127 (terminal No. 60) engine-ECU <M/T> connector or C-122 (terminal No. 3) engine-A/T-ECU <A/T> connector.

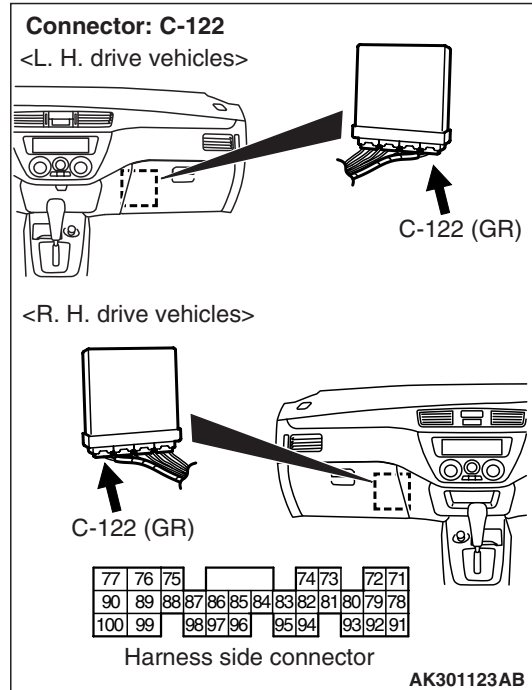
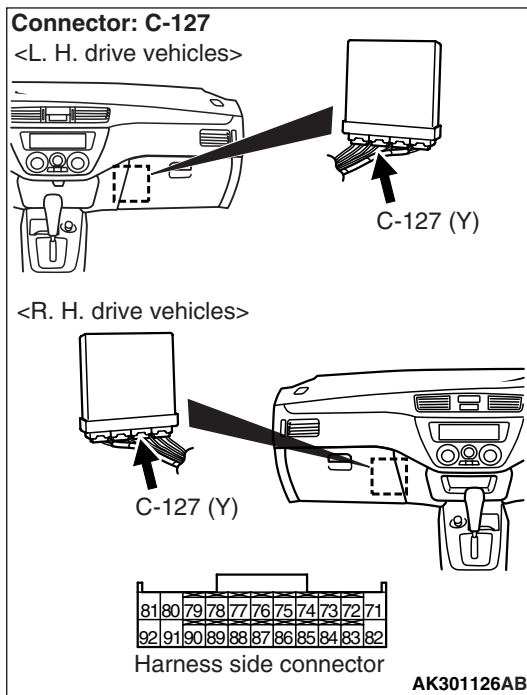
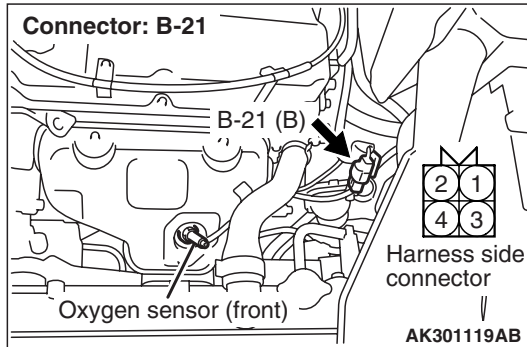

- Check earthing line for damage.

Q: Is the check result normal?

YES : Go to Step 11 .

NO : Repair.

STEP 11. Check the trouble symptoms.

Q: Does trouble symptom persist?

YES : Replace engine-ECU <M/T> or engine-A/T-ECU <A/T>.

NO : Intermittent malfunction (Refer to GROUP 00 –How to Use Troubleshooting/Inspection Service Points P.00-5).

Code No. P0136: Oxygen Sensor (rear) System <sensor 2>

Oxygen sensor (rear) circuit

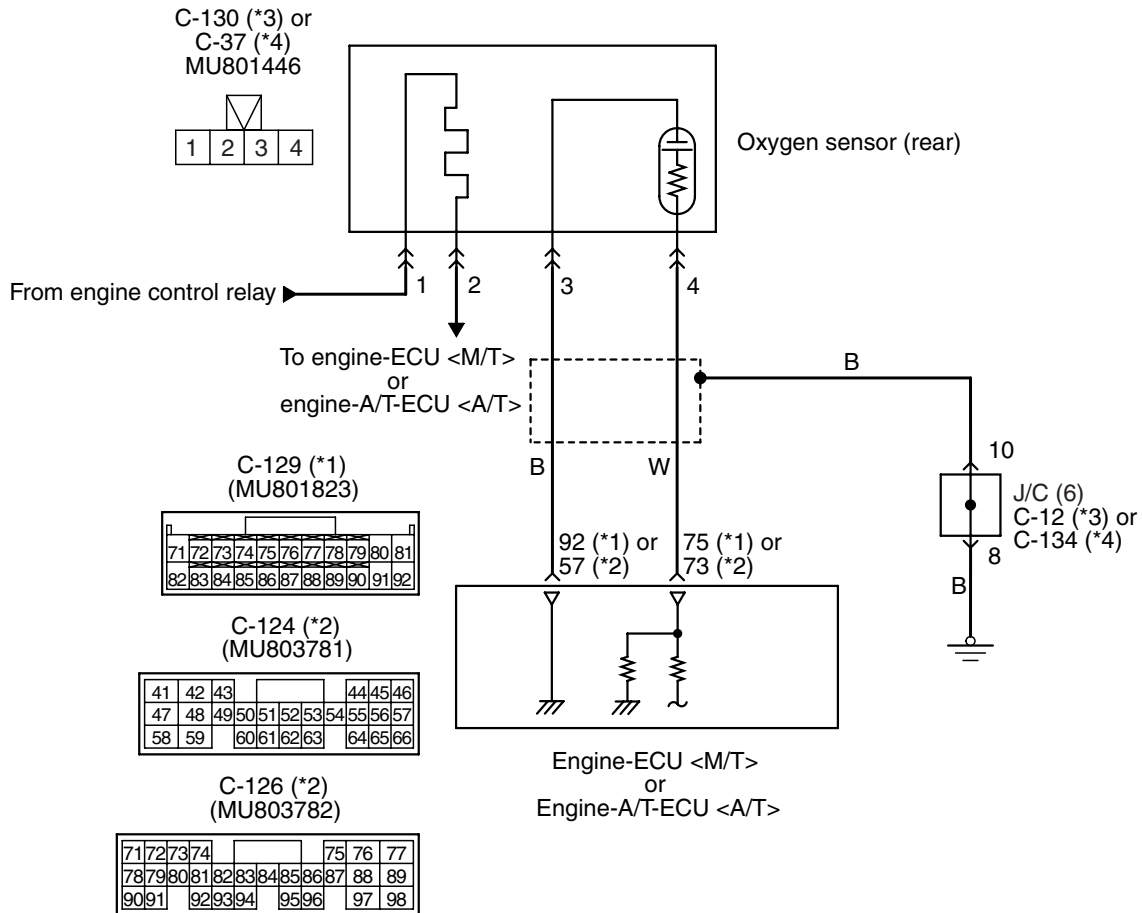

NOTE

- *1: M/T
- *2: A/T
- *3: L.H. drive vehicles
- *4: R.H. drive vehicles

Wire colour code

B: Black LG: Light green G: Green L: Blue W: White Y: Yellow SB: Sky blue BR: Brown O: Orange GR: Gray
R: Red P: Pink V: Violet

AK401350 AB

OPERATION

- The sensor signal is inputted to the engine-ECU (terminal No. 75) <M/T> or engine-A/T-ECU (terminal No. 73) <A/T> from the oxygen sensor (rear) output terminal (terminal No. 4).
- The oxygen sensor (rear) (terminal No. 3) is earthed with engine-ECU (terminal No. 92) <M/T> or engine-A/T-ECU (terminal No. 57) <A/T>.

FUNCTION

- The oxygen sensor (rear) converts the concentration of oxygen in the exhaust emission into a voltage signal and inputs the voltage signal to the engine-ECU <M/T> or engine-A/T-ECU <A/T>.
- When the air-fuel ratio is richer than the theoretical air-fuel ratio, the oxygen sensor (rear) outputs a voltage of about 1 V. When it is leaner than the theoretical air-fuel ratio, it outputs a voltage of about 0 V.

- In response to the signal, the engine-ECU <M/T> or engine-A/T-ECU <A/T> controls the fuel injection amount so that the air-fuel ratio can be equivalent to the theoretical air-fuel ratio.

TROUBLE JUDGMENT

Check Conditions

- Above 3 minutes later after the engine has started up.
- The engine coolant temperature is 82° C or higher.
- The engine speed is 1,200 r/min or more.
- The volumetric efficiency is 25% or more.
- The monitoring time is 5 seconds.

Judgment Criteria

- When the oxygen sensor (rear) output voltage is 0.2 V or less and a power voltage of 5 V is applied to the oxygen sensor (rear) in the engine-ECU<M/T> or engine-A/T-ECU <A/T>, the sensor output voltage is 4.5 V or more.

PROBABLE CAUSE

- Failed oxygen sensor
- Open/short circuit in oxygen sensor (rear) circuit or loose connector contact
- Failed engine-ECU <M/T>
- Failed engine-A/T-ECU <A/T>

DIAGNOSIS PROCEDURE

NOTE:

*1: L.H. drive vehicles

*2: R.H. drive vehicles

STEP 1. M.U.T.-II/III data list

- Refer to data list reference table P.13A-376.
 - a. Item 59: Oxygen sensor (rear)

Q: Is the check result normal?

YES : Intermittent malfunction (Refer to GROUP 00 –How to Use Troubleshooting/Inspection Service Points P.00-5).

NO : Go to Step 2 .

STEP 2. Connector check: C-130*¹ or C-37*² oxygen sensor (rear) connector

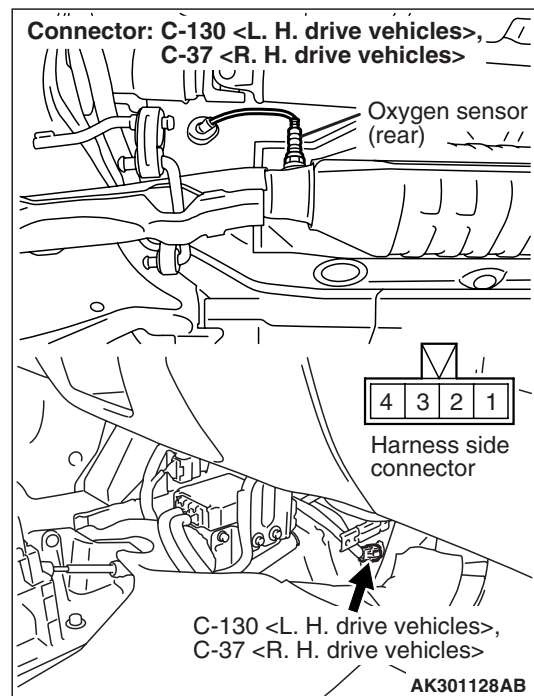

Q: Is the check result normal?

YES : Go to Step 3 .

NO : Repair or replace.

STEP 3. Perform resistance measurement at C-130*¹ or C-37*² oxygen sensor (rear) connector.

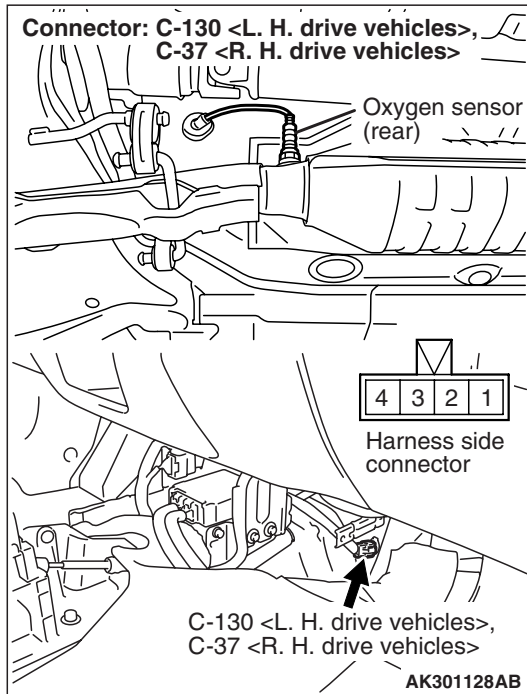

- Disconnect connector, and measure at harness side.
- Resistance between terminal No. 3 and earth.
OK: Continuity (2 Ω or less)

Q: Is the check result normal?

YES : Go to Step 7 .

NO : Go to Step 4 .

STEP 4. Connector check: C-129 engine-ECU <M/T> connector or C-124 engine-A/T-ECU <A/T> connector

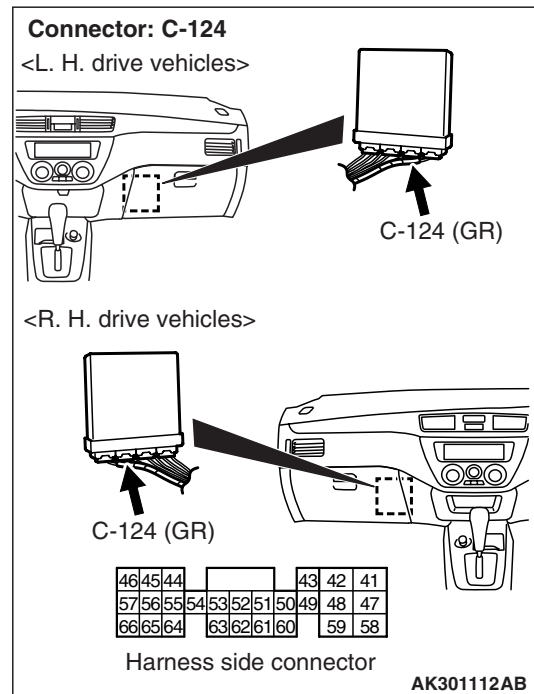
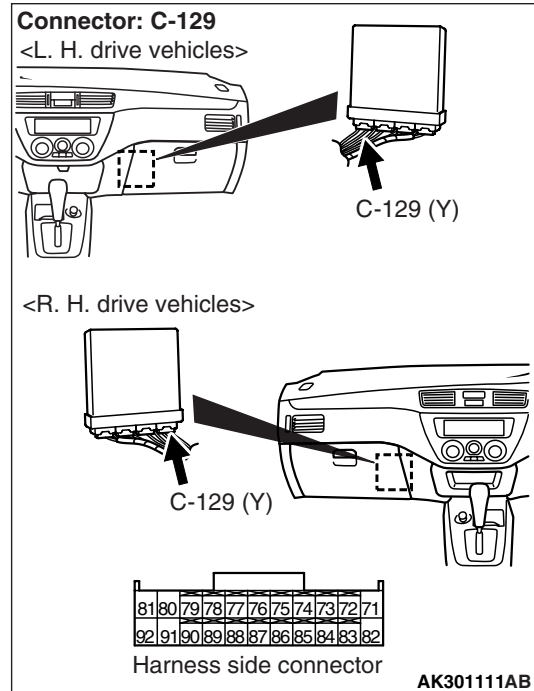

Q: Is the check result normal?

YES : Go to Step 5 .

NO : Repair or replace.

STEP 5. Check harness between C-130*¹ or C-37*² (terminal No. 3) oxygen sensor (rear) connector and C-129 (terminal No. 92) engine-ECU <M/T> connector or C-124 (terminal No. 57) engine-A/T-ECU <A/T> connector.

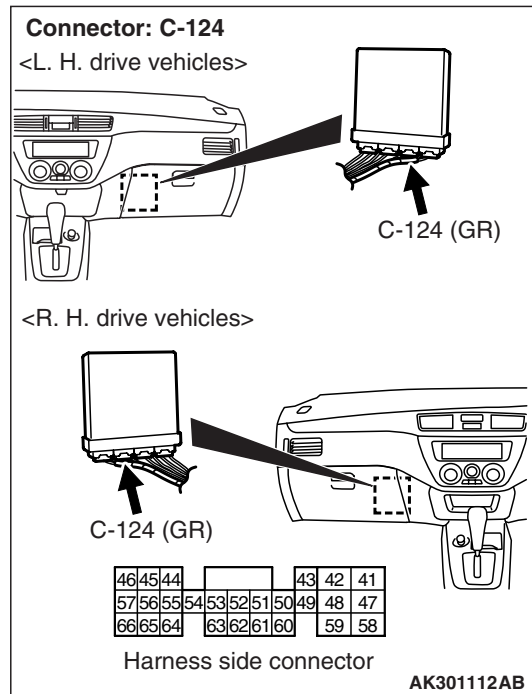
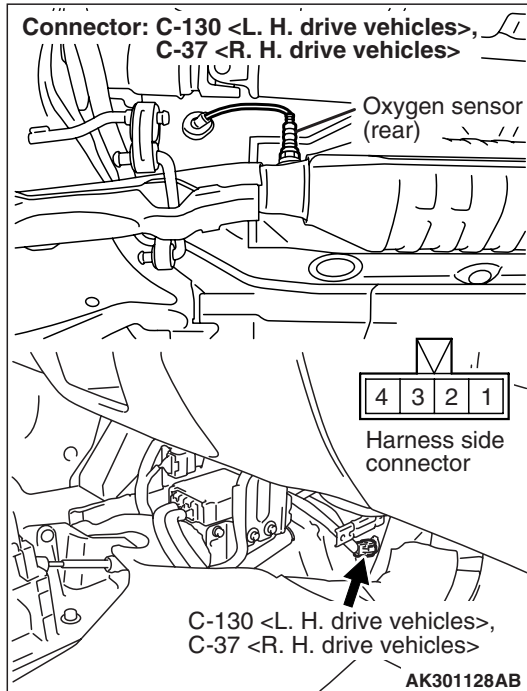

- Check earthing line for open circuit and damage.

Q: Is the check result normal?

YES : Go to Step 6 .

NO : Repair.

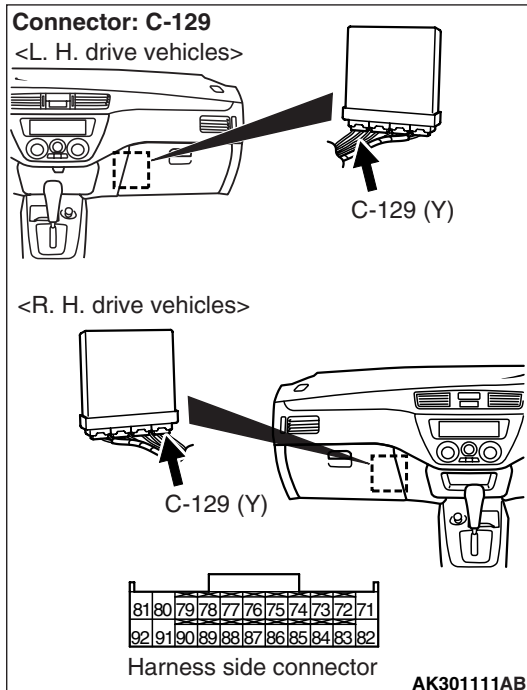

STEP 6. M.U.T.-II/III data list

- Refer to data list reference table [P.13A-376](#).
 - a. Item 59: Oxygen sensor (rear)

Q: Is the check result normal?

YES : Intermittent malfunction (Refer to GROUP 00 –How to Use Troubleshooting/Inspection Service Points [P.00-5](#)).

NO : Replace engine-ECU <M/T> or engine-A/T-ECU <A/T>.

**STEP 7. Perform voltage measurement at C-130*¹
or C-37*² oxygen sensor (rear) connector.**

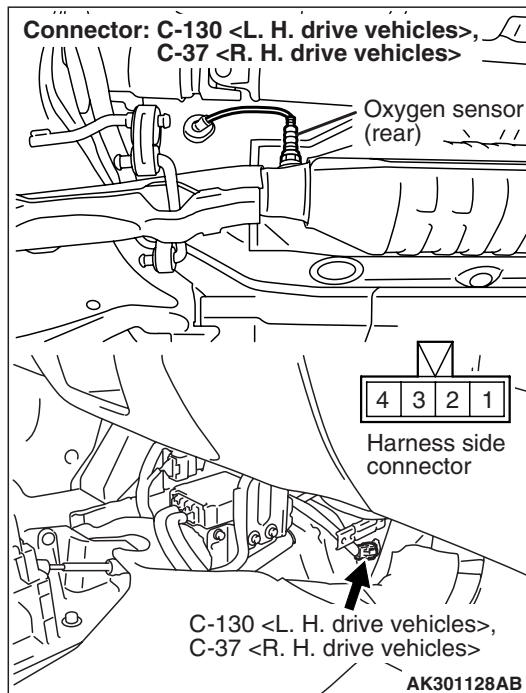

- Use special tool test harness (MB991658) to connect connector, and measure at pick-up harness.
- Engine: After warm-up
- Ignition switch: ON
- Voltage between terminal No. 3 and earth.

OK: 0.5 V or less

Q: Is the check result normal?

YES : Go to Step 9 .

NO : Go to Step 8 .

STEP 8. Connector check: C-129 engine-ECU <M/T> connector or C-124 engine-A/T-ECU <A/T> connector

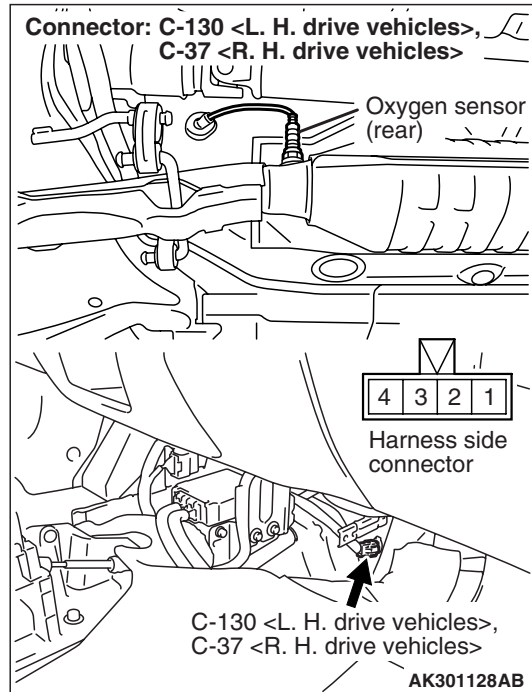
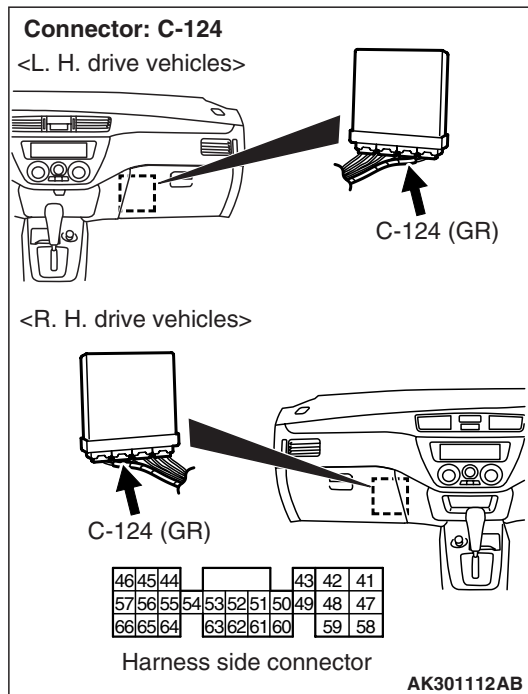
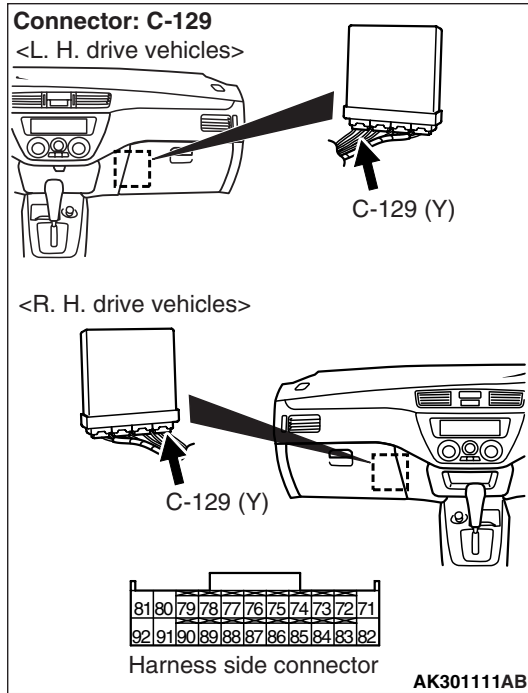

Q: Is the check result normal?

YES : Check and repair harness between C-130*¹

or C-37*² (terminal No. 3) oxygen sensor connector and C-129 (terminal No. 92) engine-ECU <M/T> connector or C-124 (terminal No. 57) engine-A/T-ECU <A/T> connector.

- Check earthing line for damage.

NO : Repair or replace.

STEP 9. Perform voltage measurement at C-130*1 or C-37*2 oxygen sensor (rear) connector.

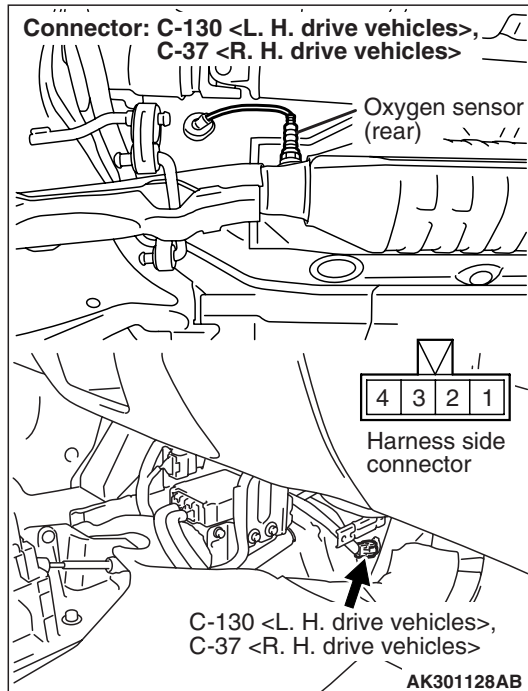

- Use special tool test harness (MB991658) to connect connector, and measure at pick-up harness.
- Engine: After warm-up
- Voltage between terminal No. 4 and earth.

OK:

600 – 1,000 mV when 200 mV or lower abrupt racing is done a few seconds after abrupt deceleration from 4,000 r/min.

Q: Is the check result normal?

YES : Go to Step 12 .

NO : Go to Step 10 .

STEP 10. Check oxygen sensor (rear) itself.

- Check oxygen sensor (rear) itself (Refer to P.13A-406).

Q: Is the check result normal?

YES : Go to Step 11 .

NO : Replace oxygen (rear) sensor.

STEP 11. Connector check: C-129 engine-ECU <M/T> connector or C-126 engine-A/T-ECU <A/T> connector

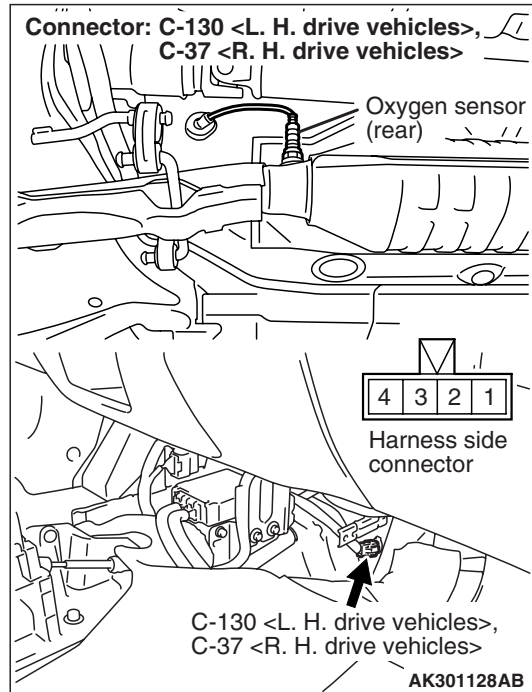
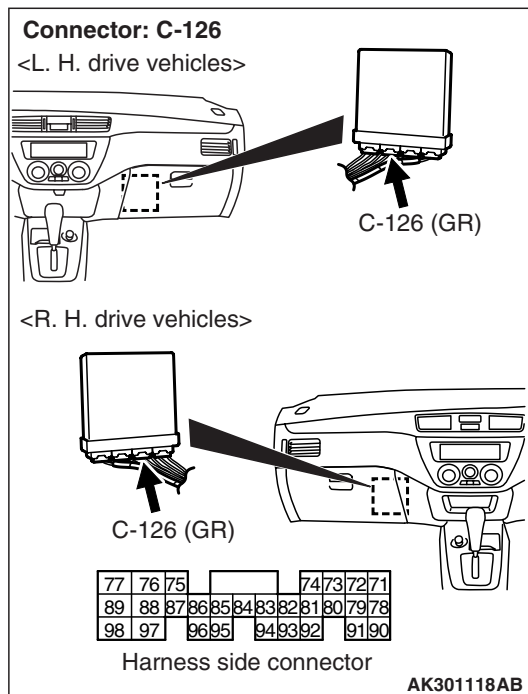
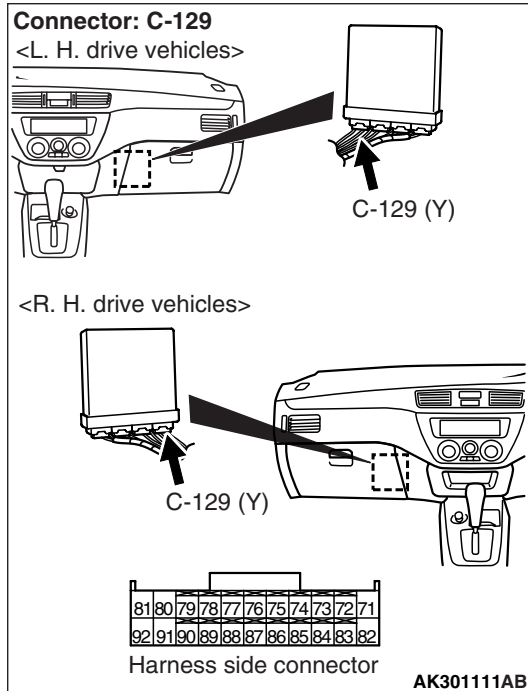

Q: Is the check result normal?

YES : Check and repair harness between C-130*¹

or C-37*² (terminal No. 4) oxygen sensor connector and C-129 (terminal No. 75) engine-ECU <M/T> connector or C-126 <terminal No. 73> engine-A/T-ECU <A/T> connector.

- Check output line for damage.

NO : Repair or replace.

STEP 12. Perform voltage measurement at C-129 engine-ECU <M/T> connector or C-126 engine-A/T-ECU <A/T> connector.

OK:
600 – 1,000 mV when 200 mV or lower abrupt racing is done a few seconds after abrupt deceleration from 4,000 r/min.

Q: Is the check result normal?
YES : Go to Step 14 .
NO : Go to Step 13 .

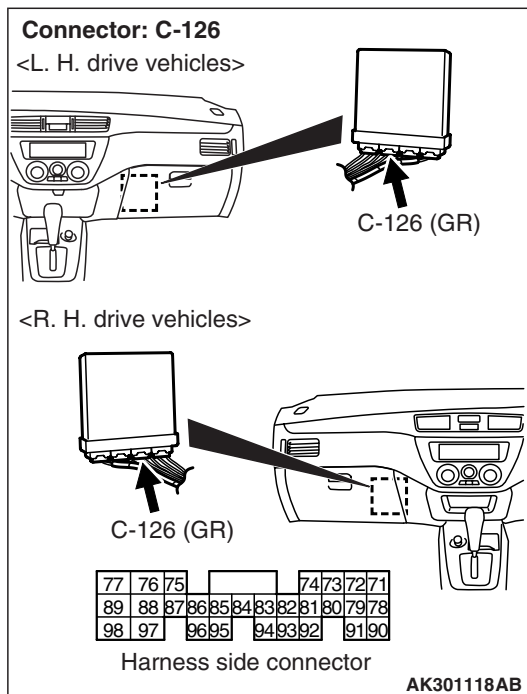
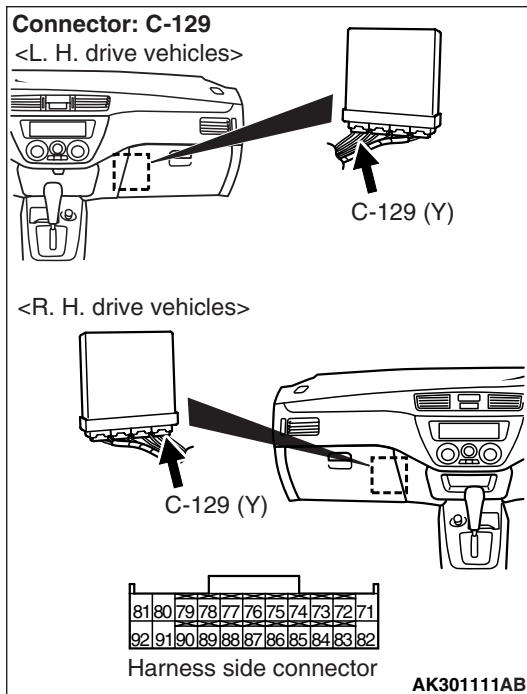

- Measure engine-ECU <M/T> or engine-A/T-ECU <A/T> terminal voltage.
- Transmission: Neutral <M/T> or P range <A/T>
- Engine: After warm-up
- Voltage between terminal No. 75 <M/T> or terminal No. 73 <A/T> and earth.

STEP 13. Connector check: C-129 engine-ECU <M/T> connector or C-126 engine-A/T-ECU <A/T> connector

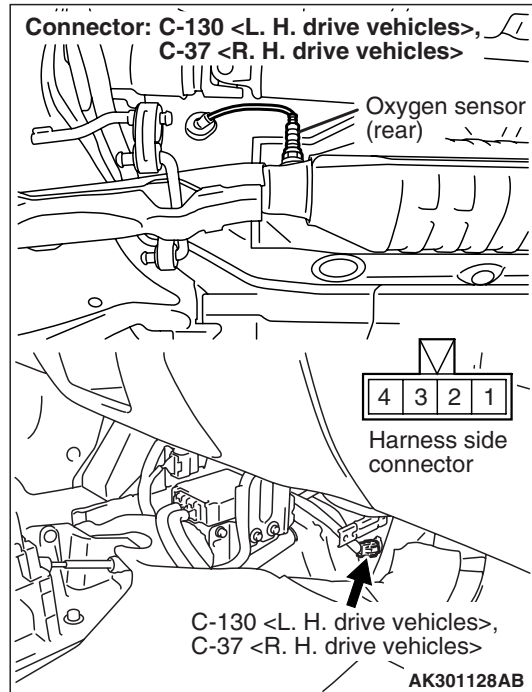
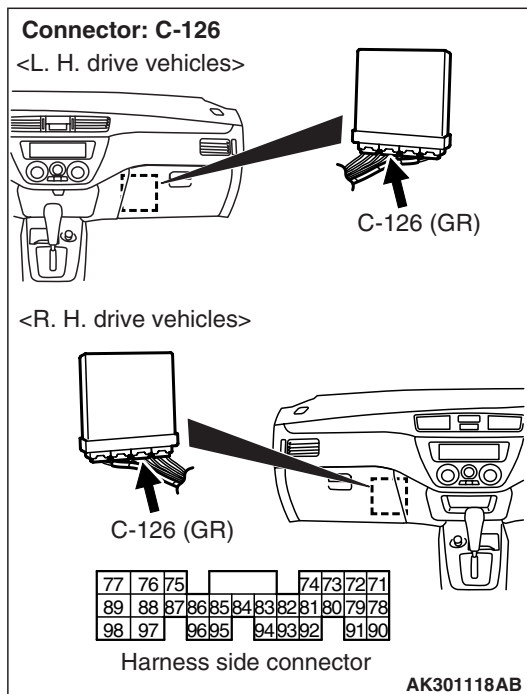
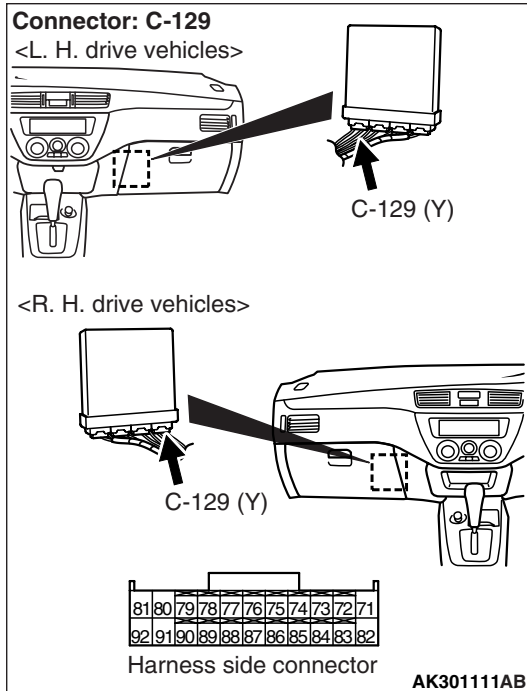

Q: Is the check result normal?

YES : Check and repair harness between C-130*¹ or C-37*² (terminal No. 4) oxygen sensor (rear) connector and C-129 (terminal No. 75) engine-ECU <M/T> connector or C-126 <terminal No. 73> engine-A/T-ECU <A/T> connector.

- Check output line for open circuit.

NO : Repair or replace.

**STEP 14. Connector check: C-129 engine-ECU
<M/T> connector or C-126 engine-A/T-ECU <A/T>
connector**

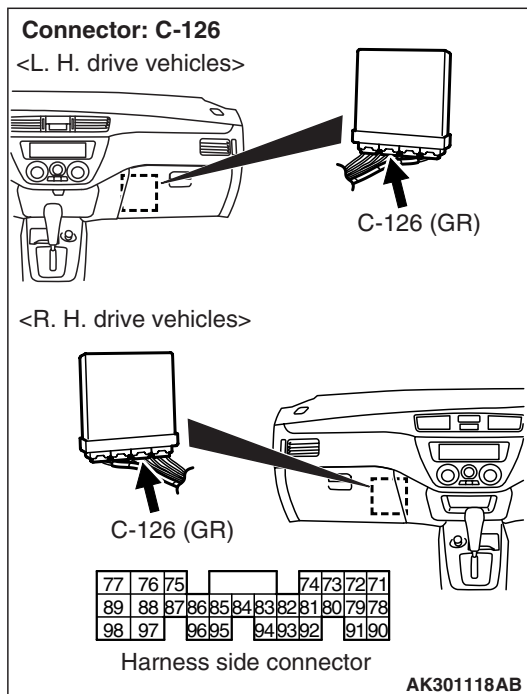
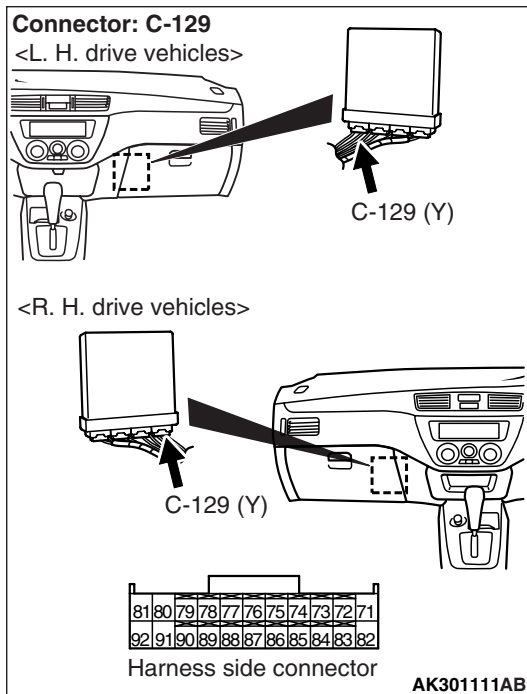

Q: Is the check result normal?

YES : Go to Step 6 .

NO : Repair or replace.

Code No. P0141: Oxygen Sensor (rear) Heater System <sensor 2>

Oxygen sensor (rear) heater circuit

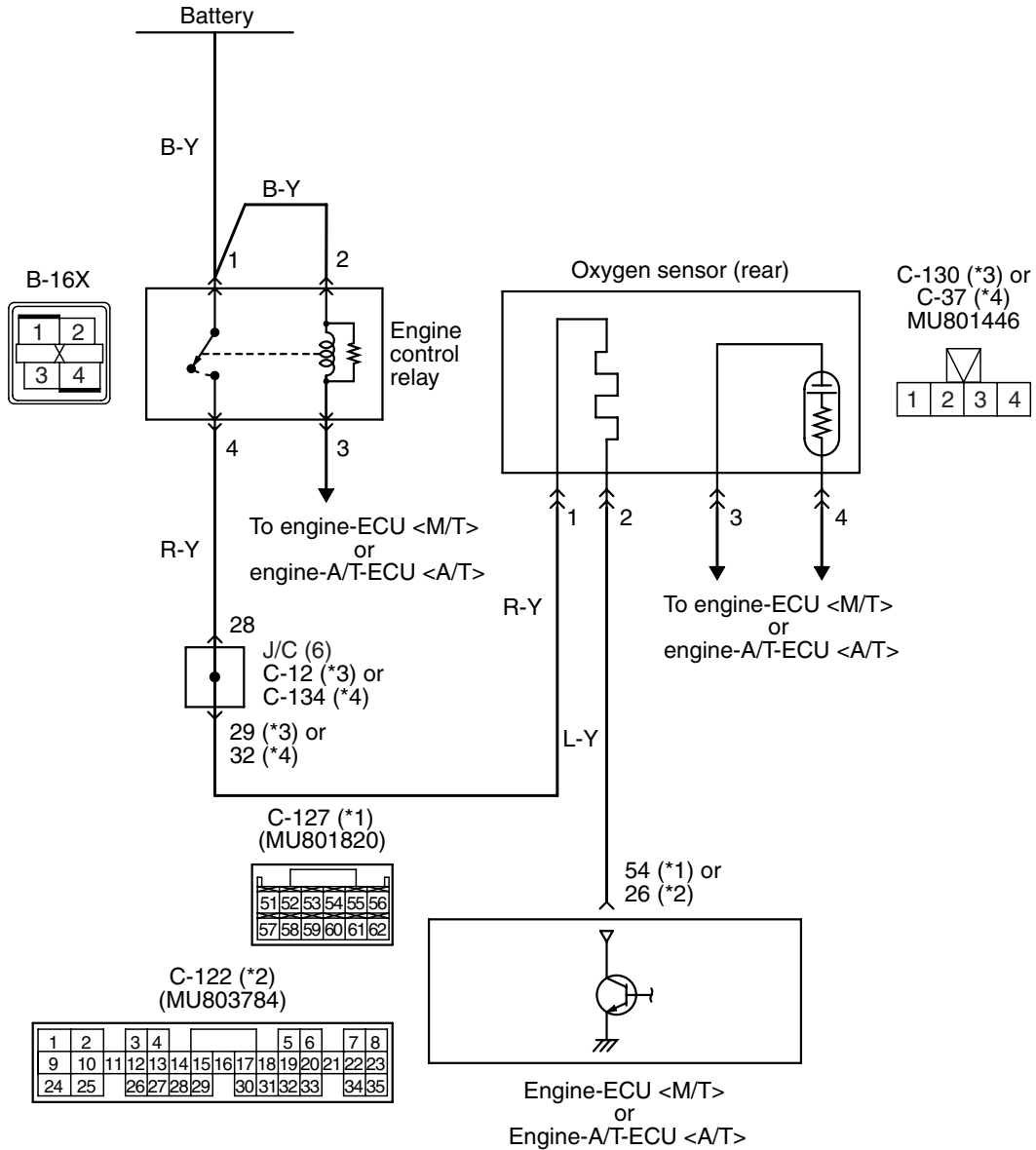

NOTE

- *1: M/T
- *2: A/T
- *3: L.H. drive vehicles
- *4: R.H. drive vehicles

Wire colour code

B: Black LG: Light green G: Green L: Blue W: White Y: Yellow SB: Sky blue BR: Brown O: Orange GR: Gray R: Red P: Pink V: Violet

OPERATION

- Power is supplied to the heater power terminal (terminal No. 1) of the oxygen sensor (rear) connector from the engine control relay (terminal No. 4).
- The heater (terminal No. 2) of the oxygen sensor (rear) connector is controlled by the power transistor in the engine-ECU (terminal No. 54) <M/T> or engine-A/T-ECU (terminal No. 26) <A/T>.

FUNCTION

- The power supply to the oxygen sensor (rear) heater is controlled by the ON/OFF control of the power transistor in the engine-ECU <M/T> or engine-A/T-ECU <A/T>.
- Heating the oxygen sensor (rear) heater enables the oxygen sensor to provide good response even when the exhaust emission temperature is low.

TROUBLE JUDGMENT

Check Conditions

- The engine coolant temperature is 20° C or higher.
- The oxygen sensor (rear) heater is in "ON" position.
- The engine speed is 50 r/min or more.
- The battery voltage is 11 – 16 V.

Judgment Criteria

- The heater current of front oxygen sensor (rear) heater is below 0.2 A or above 3.5 A for 1 second.

PROBABLE CAUSE

- Failed oxygen sensor (rear) heater
- Open/short circuit in oxygen sensor (rear) circuit or loose connector contact
- Failed engine-ECU <M/T>
- Failed engine-A/T-ECU <A/T>

DIAGNOSIS PROCEDURE

NOTE:

*1: L.H. drive vehicles

*2: R.H. drive vehicles

STEP 1. Connector check: C-130*¹ or C-37*² oxygen sensor (rear) connector

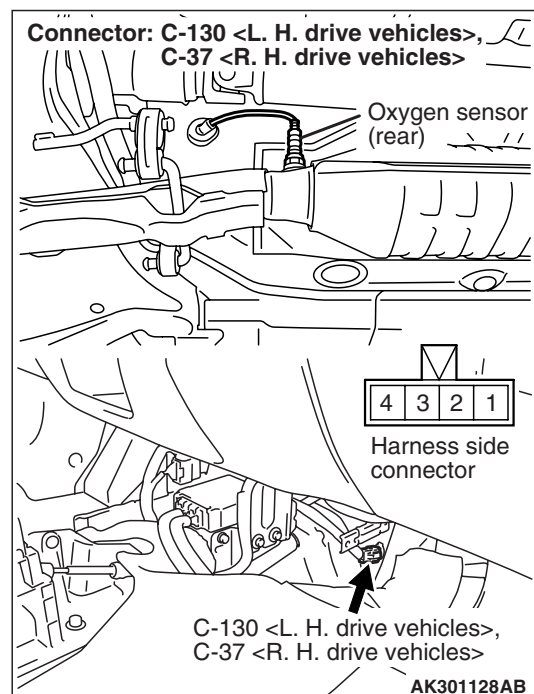

Q: Is the check result normal?

YES : Go to Step 2 .

NO : Repair or replace.

STEP 2. Perform resistance measurement at C-130*¹ or C-37*² oxygen sensor (rear) connector.

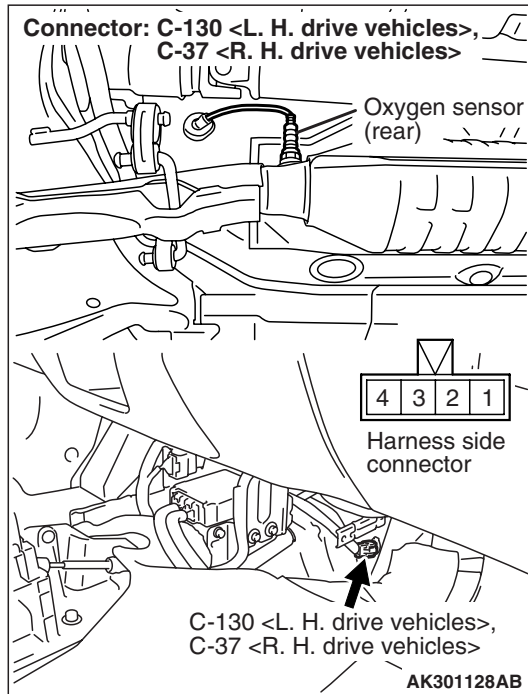

- Disconnect connector, and measure at sensor side.
- Resistance between terminal No. 1 and No. 2.
OK: 4 – 8 Ω

Q: Is the check result normal?

YES : Go to Step 3 .

NO : Replace oxygen (rear) sensor.

STEP 3. Perform voltage measurement at C-130*¹ or C-37*² oxygen sensor (rear) connector.

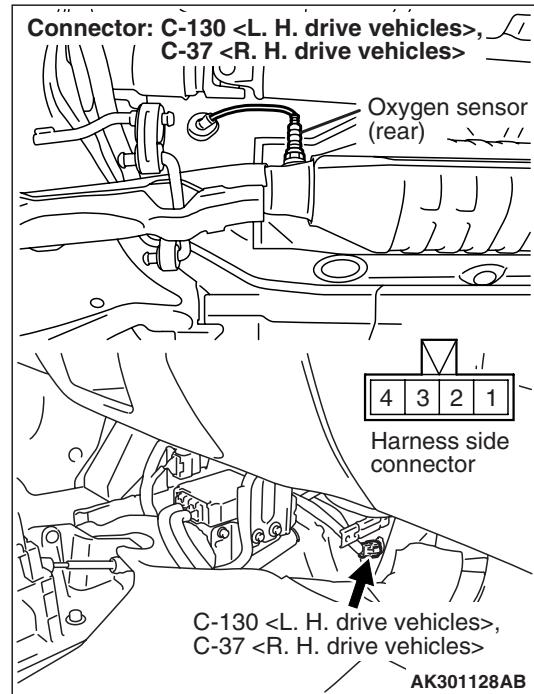

- Disconnect connector, and measure at harness side.
- Ignition switch: ON
- Voltage between terminal No. 1 and earth.

OK: System voltage

Q: Is the check result normal?

YES : Go to Step 5 .

NO : Go to Step 4 .

STEP 4. Connector check: B-16X engine control relay connector

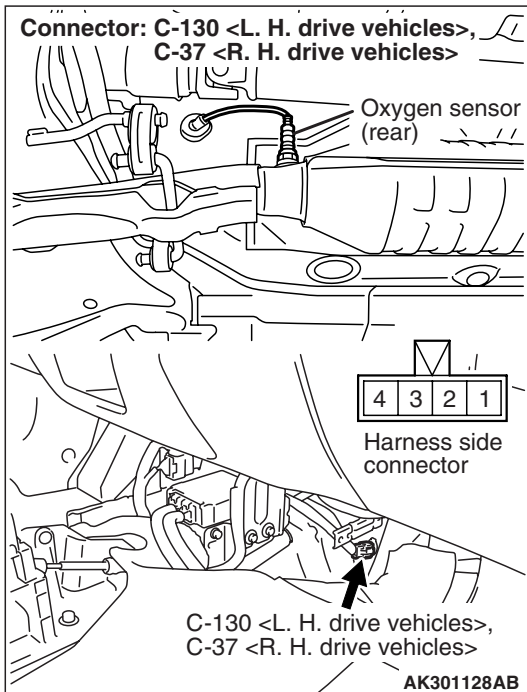
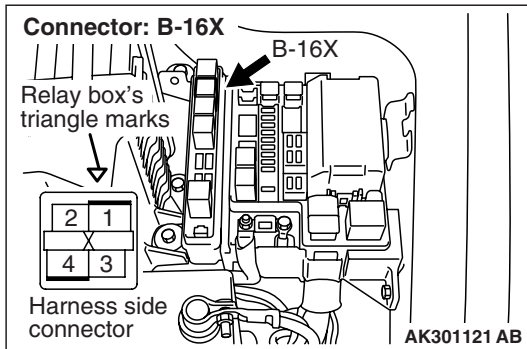

Q: Is the check result normal?

YES : Check intermediate connector C-12*¹ or C-134*², and repair if necessary. If intermediate connector is normal, check and repair harness between C-130*¹ or C-37*² (terminal No. 1) oxygen sensor (rear) connector and B-16X (terminal No. 4) engine control relay connector.

- Check power supply line for open/short circuit.

NO : Repair or replace.

STEP 5. Perform voltage measurement at C-127 engine-ECU <M/T> connector or C-122 engine-A/T-ECU <A/T> connector.

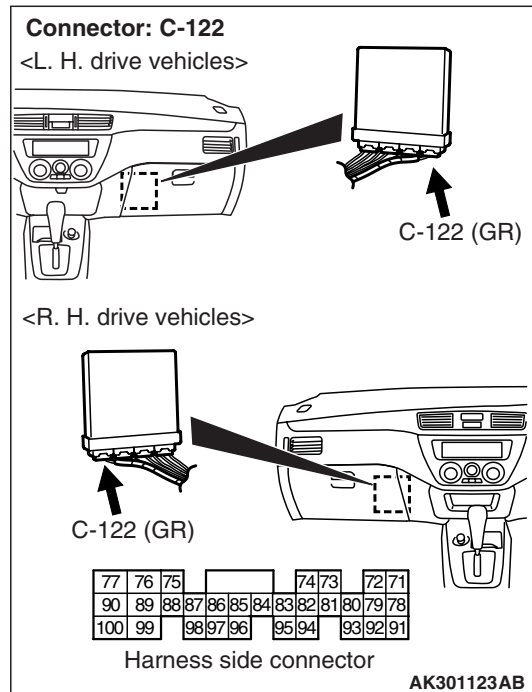
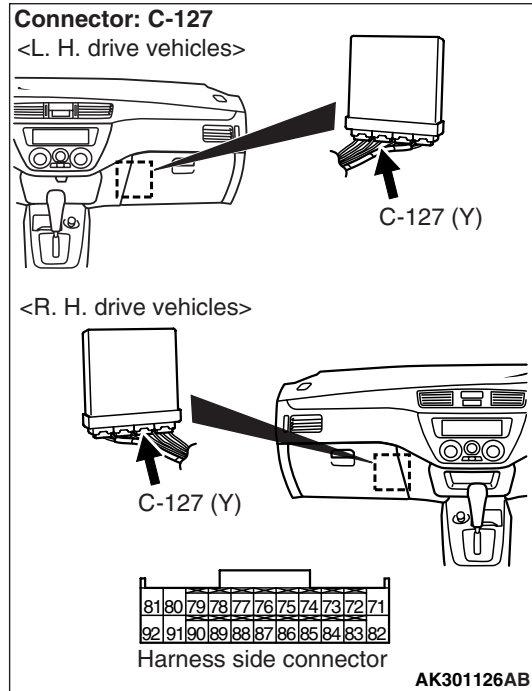

- Measure engine-ECU <M/T> or engine-A/T-ECU <A/T> terminal voltage.
- Ignition switch: ON
- Voltage between terminal No. 54 <M/T> or terminal No. 26 <A/T> and earth.

OK: System voltage

Q: Is the check result normal?

YES : Go to Step 8 .

NO : Go to Step 6 .

STEP 6. Connector check: C-127 engine-ECU <M/T> connector or C-122 engine-A/T-ECU <A/T> connector

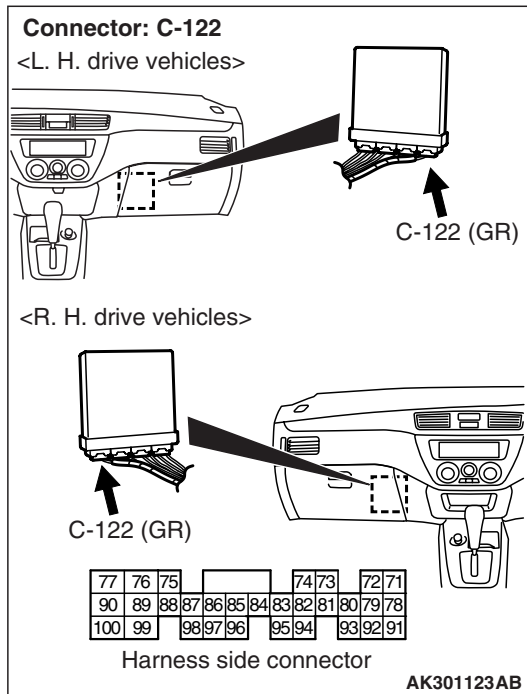
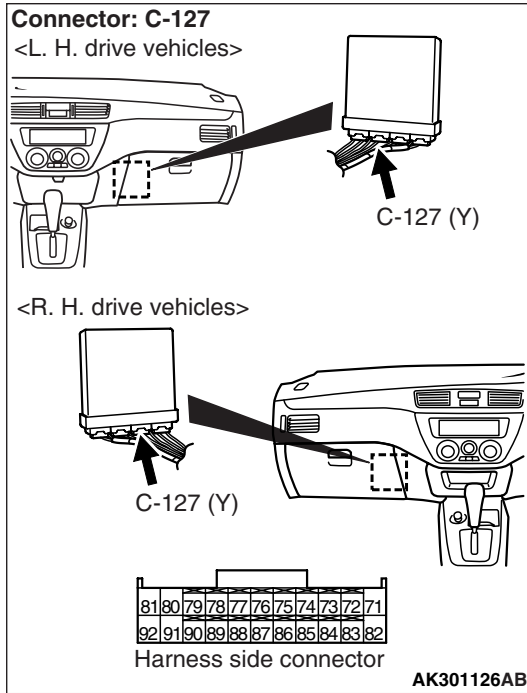

Q: Is the check result normal?

YES : Go to Step 7 .

NO : Repair or replace.

STEP 7. Check harness between C-130*¹ or C-37*² (terminal No. 2) oxygen sensor connector and C-127 (terminal No. 54) engine-ECU <M/T> connector or C-122 (terminal No. 26) engine-A/T-ECU <A/T> connector.

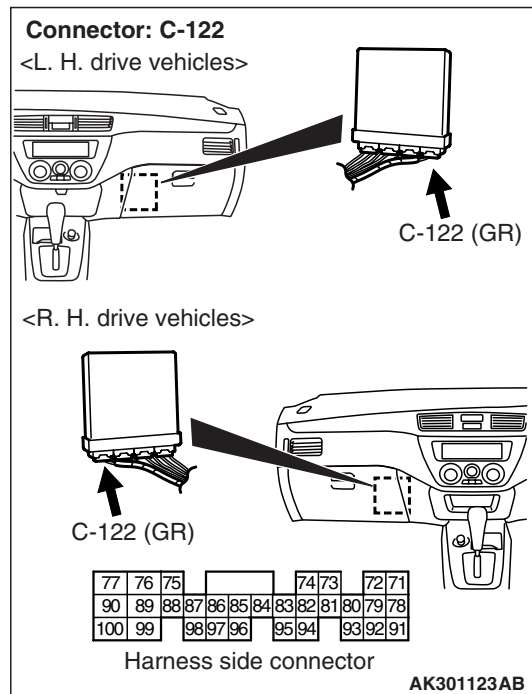
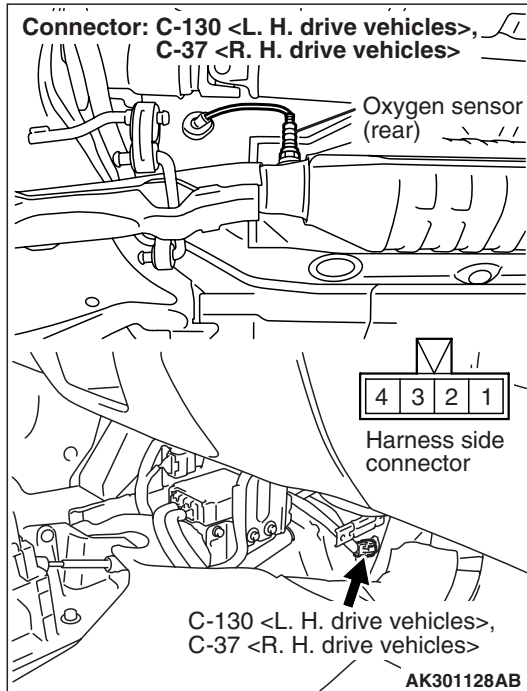

- Check earthing line for open/short circuit.

Q: Is the check result normal?

YES : Replace engine-ECU <M/T> or engine-A/T-ECU <A/T>.

NO : Repair.

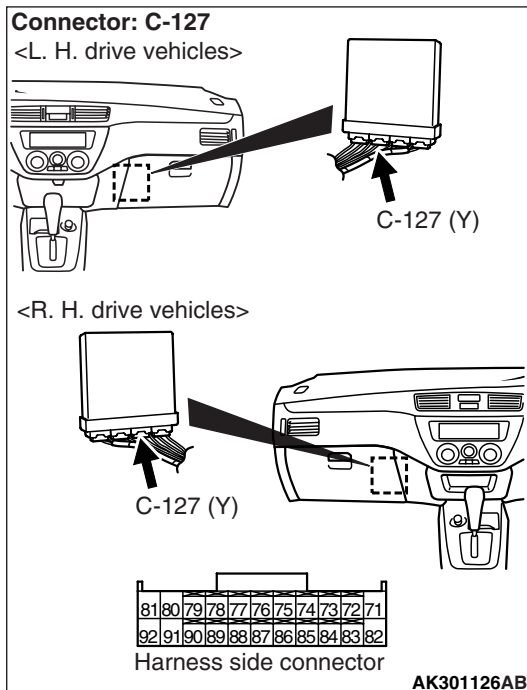

STEP 8. Connector check: C-127 engine-ECU <M/T> connector or C-122 engine-A/T-ECU <A/T> connector

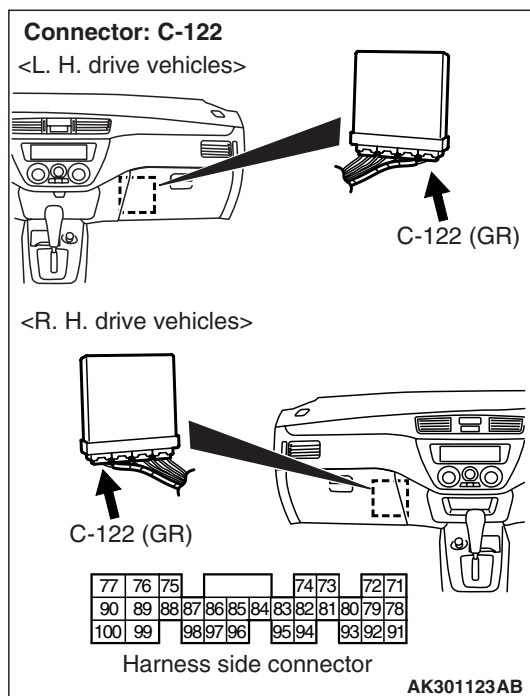
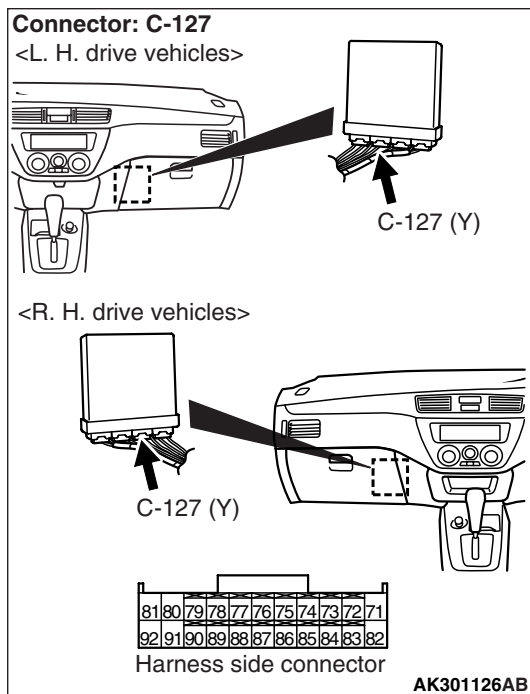

STEP 9. Check harness between C-130*¹ or C-37*² (terminal No. 1) oxygen sensor connector and B-16X (terminal No. 4) engine control relay connector.

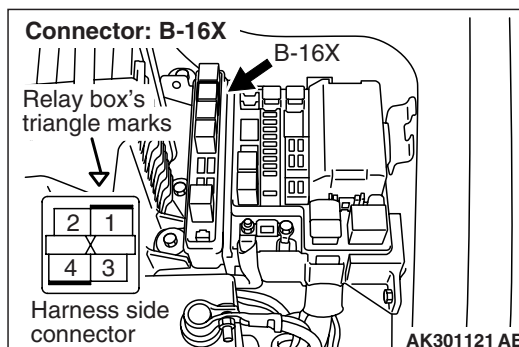
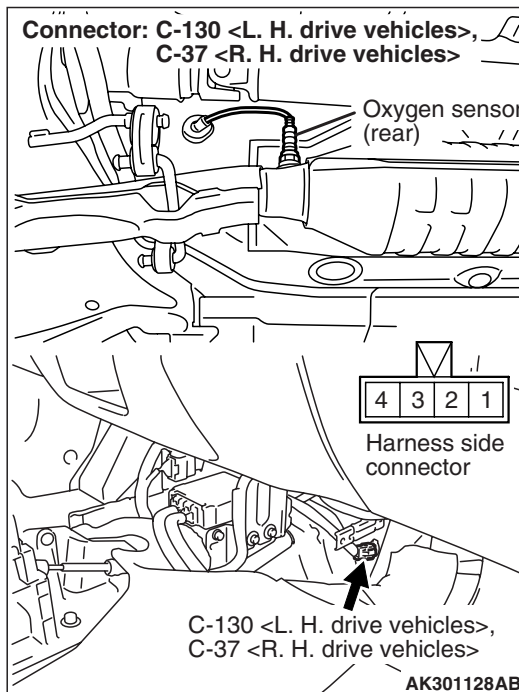

NOTE: Before checking harness, check intermediate connector C-12*¹ or C-134*², and repair if necessary.

- Check power supply line for damage.

Q: Is the check result normal?

YES : Go to Step 10 .

NO : Repair.

Q: Is the check result normal?

YES : Go to Step 9 .

NO : Repair or replace.

STEP 10. Check harness between C-130*¹ or C-37*² (terminal No. 2) oxygen sensor connector and C-127 (terminal No. 54) engine-ECU connector <M/T> connector or C-122 (terminal No. 26) engine-A/T-ECU <A/T>.

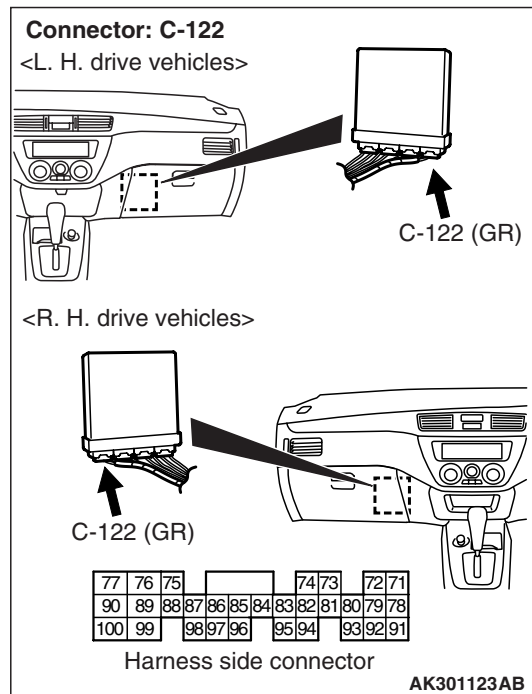
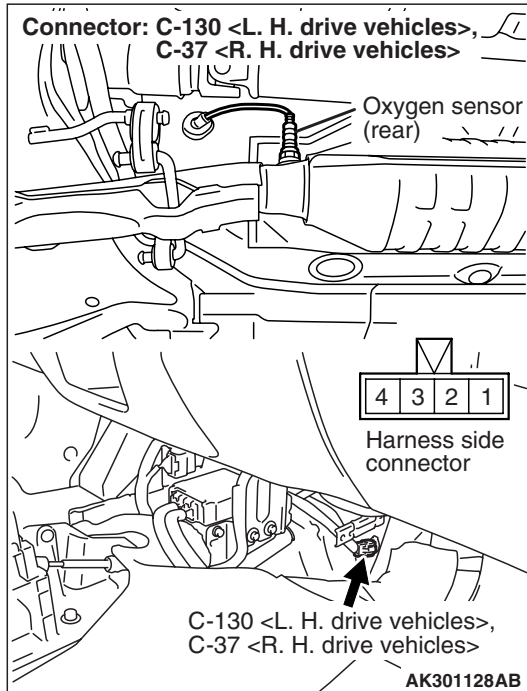

- Check earthing line for damage.

Q: Is the check result normal?

YES : Go to Step 11 .

NO : Repair.

STEP 11. Check the trouble symptoms.

Q: Does trouble symptom persist?

YES : Replace engine-ECU <M/T> or engine-A/T-ECU <A/T>.

NO : Intermittent malfunction (Refer to GROUP 00 –How to Use Troubleshooting/Inspection Service Points P.00-5).

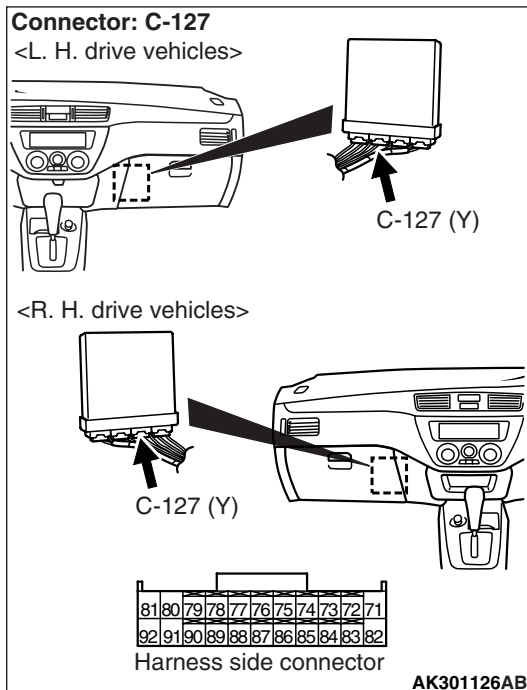

Code No. P0170: Abnormal Fuel System

OPERATION

- Refer to P0201 injector circuit [P.13A-115](#).
- Refer to P0202 injector circuit [P.13A-121](#).
- Refer to P0203 injector circuit [P.13A-127](#).
- Refer to P0204 injector circuit [P.13A-133](#).

FUNCTION

- If the fuel system goes out of order, the fuel correction value will become larger.
- The engine-ECU <M/T> or engine-A/T-ECU <A/T> checks whether the fuel correction value is within the standard limits.

TROUBLE JUDGMENT**Check Conditions**

- In learning air-fuel ratio

Judgment Criteria

- The compensation value of fuel injection amount is too low for 2 seconds or more.

or

- The compensation value of fuel injection amount is too high for 2 seconds or more.

PROBABLE CAUSE

- Failed fuel supply system
- Failed oxygen sensor (front)
- Failed intake air temperature sensor
- Failed purge control solenoid valve
- Failed engine-ECU <M/T>
- Failed engine-A/T-ECU <A/T>

DIAGNOSIS PROCEDURE

STEP 1. M.U.T.-II/III diagnosis code

- Q: Is any other diagnosis code than P0170 output?**
YES : Inspection chart for diagnosis code (Refer to [P.13A-17](#)).
- NO** : Go to Step 2 .

STEP 2. M.U.T.-II/III data list

- Refer to data list reference table [P.13A-376](#).
 - a. Item 13: Intake air temperature sensor
 - b. Item 21: Engine coolant temperature sensor
 - c. Item 32: Manifold absolute pressure sensor

Q: Are the check results normal?

YES : Go to Step 3 .

NO : Perform the diagnosis code classified check procedure for the sensor that has shown an abnormal data value (Refer to Inspection Chart for diagnosis codes [P.13A-17](#)).

STEP 3. Check for intake of air from intake hose and inlet manifold.**Q: Is the check result normal?**

YES : Go to Step 4 .

NO : Repair.

STEP 4. Check for leakage of exhaust emission from exhaust manifold.**Q: Is the check result normal?**

YES : Go to Step 5 .

NO : Repair.

STEP 5. Check throttle body (throttle valve portion) for contamination.**Q: Is the check result normal?**

YES : Go to Step 6 .

NO : Clean throttle body (throttle valve portion) (Refer to [P.13A-398](#)).

STEP 6. M.U.T.-II/III data list

- Refer to data list reference table [P.13A-376](#).
 - a. Item 11: Oxygen sensor (front).

Q: Is the check result normal?

YES : Go to Step 7 .

NO : Check oxygen sensor (front) system (Refer to [P.13A-74](#), Code No. P0130).

STEP 7. Connector Check: Injector connector

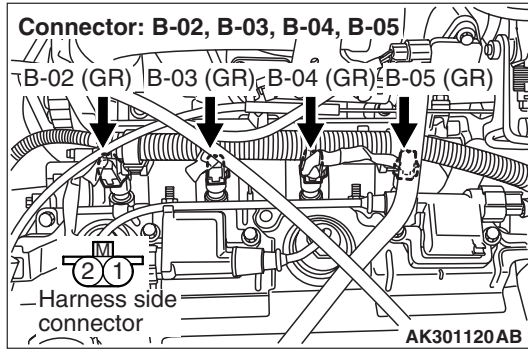

- a. B-02 (No.1 injector connector).
- b. B-03 (No.2 injector connector).
- c. B-04 (No.3 injector connector).
- d. B-05 (No.4 injector connector).

Q: Are the check results normal?

YES : Go to Step 8 .

NO : Repair or replace.

STEP 8. Check injector itself.

- Check Injector itself (Refer to [P.13A-407](#)).

Q: Is the check result normal?

YES : Go to Step 9 .

NO : Replace injector.

STEP 9. Connector check: B-16X engine control relay connector and B-123 engine-ECU <M/T> connector or C-122 engine-A/T-ECU <A/T> connector.

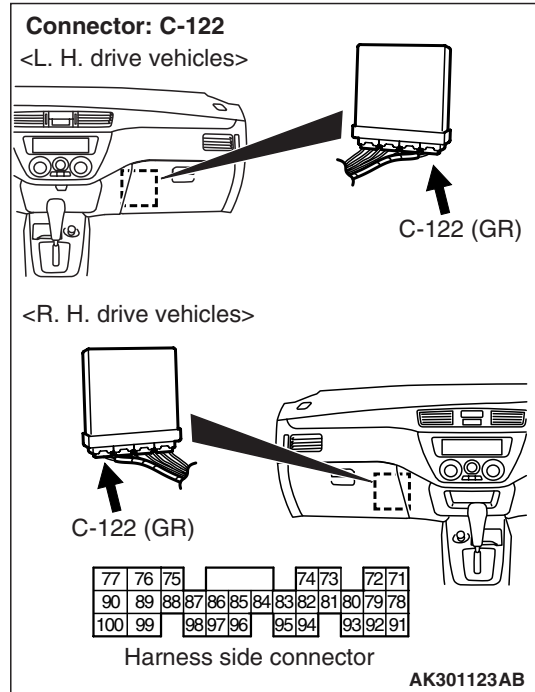
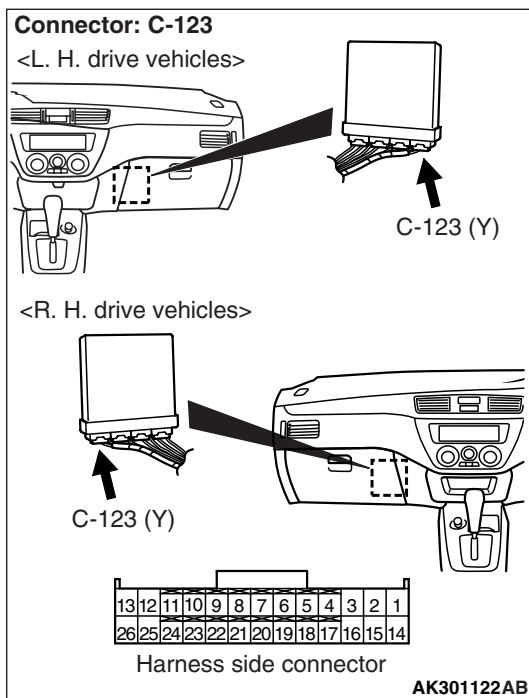
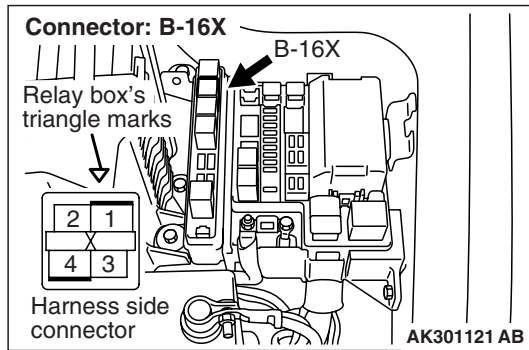

Q: Is the check result normal?
YES : Go to Step 10 .
NO : Repair or replace.

STEP 10. Check harness between B-16X engine control relay connector and injector connector.

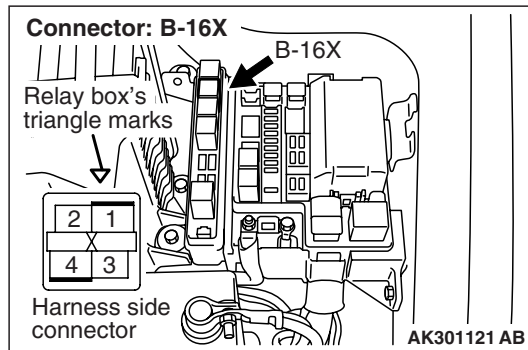
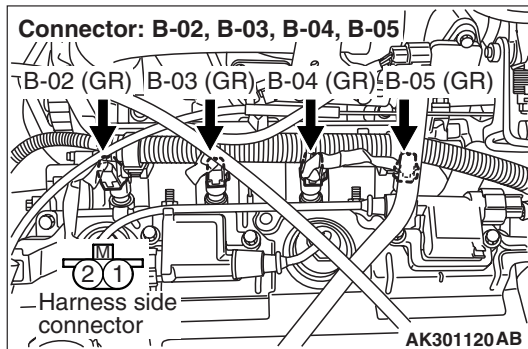

- Check harness between B-16X (terminal No. 4) engine control relay connector and B-02 (terminal No. 1) No. 1 injector connector.
- Check harness between B-16X (terminal No. 4) engine control relay connector and B-03 (terminal No. 1) No. 2 injector connector.
- Check harness between B-16X (terminal No. 4) engine control relay connector and B-04 (terminal No. 1) No. 3 injector connector.
- Check harness between B-16X (terminal No. 4) engine control relay connector and B-05 (terminal No. 1) No. 4 injector connector.
 - Check power supply line for damage.

Q: Are the check results normal?

YES : Go to Step 11 .

NO : Repair.

STEP 11. Check harness between injector connector and C-123 engine-ECU <M/T> connector or C-122 engine-A/T-ECU <A/T> connector.

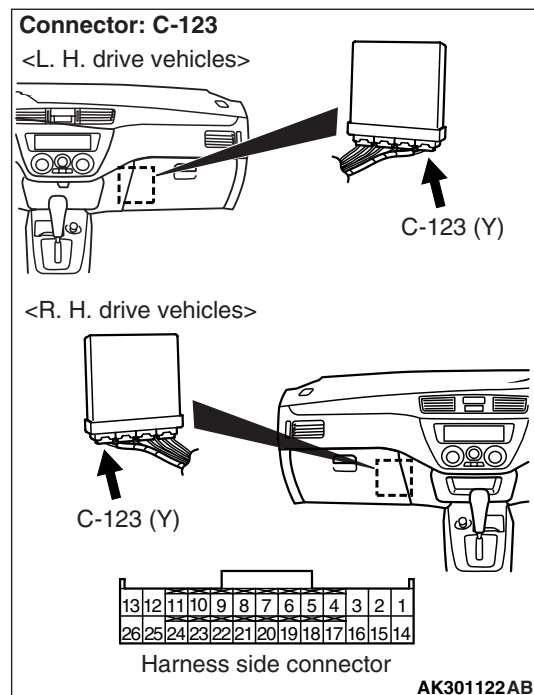
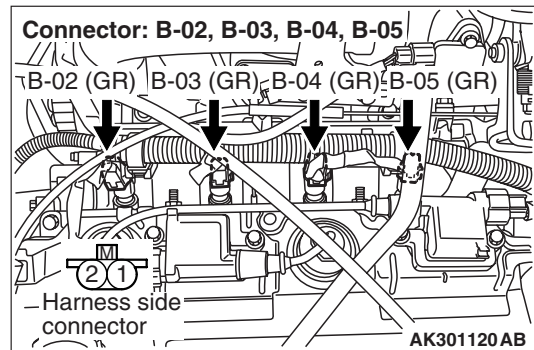

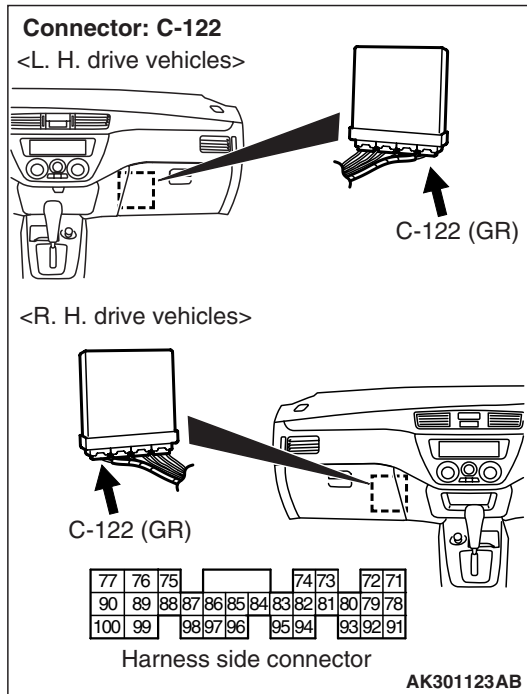
**STEP 12. Check purge control solenoid valve itself.**

- Check purge control solenoid valve itself (Refer to GROUP 17 –Emission Control System –Evaporative Emission Control System P.17-11).

Q: Is the check result normal?**YES** : Go to Step 13 .**NO** : Replace purge control solenoid valve.**STEP 13. Fuel pressure measurement.**

- Fuel pressure measurement (Refer to P.13A-399).

Q: Is the check result normal?**YES** : Replace engine-ECU <M/T> or engine-A/T-ECU <A/T>.**NO** : Repair.

- Check harness between B-02 (terminal No. 2) No. 1 injector connector and C-123 (terminal No. 1) engine-ECU <M/T> connector or C-122 (terminal No. 1) engine-A/T-ECU <A/T> connector.
- Check harness between B-03 (terminal No. 2) No. 2 injector connector and C-123 (terminal No. 14) engine-ECU <M/T> connector or C-122 (terminal No. 9) engine-A/T-ECU <A/T> connector.
- Check harness between B-04 (terminal No. 2) No. 3 injector connector and C-123 (terminal No. 2) engine-ECU <M/T> connector or C-122 (terminal No. 24) engine-A/T-ECU <A/T> connector.
- Check harness between B-05 (terminal No. 2) No. 4 injector connector and C-123 (terminal No. 15) engine-ECU <M/T> connector or C-122 (terminal No. 2) engine-A/T-ECU <A/T> connector.

Q: Are the check results normal?**YES** : Go to Step 12 .**NO** : Repair.

Code No. P0201: No. 1 Injector System

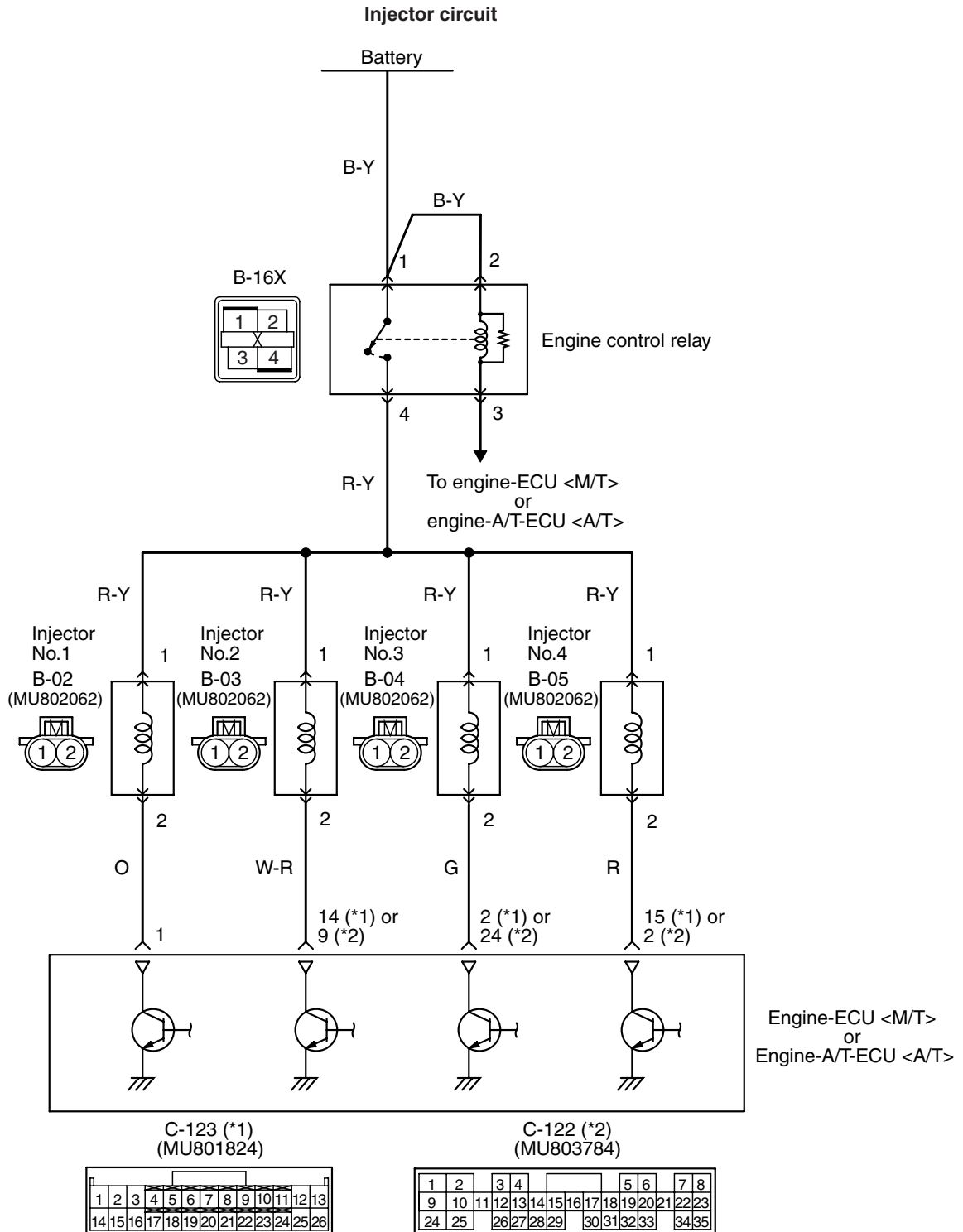

NOTE
*1: M/T
*2: A/T

Wire colour code
B: Black LG: Light green G: Green L: Blue W: White Y: Yellow SB: Sky blue BR: Brown O: Orange GR: Gray
R: Red P: Pink V: Violet

OPERATION

- Power is supplied to the injector (terminal No. 1) from the engine control relay (terminal No. 4).
- The engine-ECU (terminal No. 1) <M/T> or engine-A/T-ECU (terminal No. 1) <A/T> makes the power transistor in the unit be in "ON" position, and that makes currents go on the injector (terminal No. 2).

FUNCTION

- The engine-ECU <M/T> or engine-A/T-ECU <A/T> controls the power supply interval of the injector.
- The fuel injection amount of the injector depends on the power supply interval.

TROUBLE JUDGMENT**Check Conditions**

- The engine speed is 50 – 1,000 r/min.
- The throttle position sensor output voltage is 1.15 V or less.
- Injector not in forced drive (actuator test) mode

Judgment Criterion

- No surge voltage of the injector coil is detected for 2 seconds.

PROBABLE CAUSE

- Failed No. 1 injector
- Open/short circuit in injector circuit or loose connector contact
- Failed engine-ECU <M/T>
- Failed engine-A/T-ECU <A/T>

DIAGNOSIS PROCEDURE**STEP 1. M.U.T.-II/III actuator test**

- Refer to actuator test reference table [P.13A-383](#).
 - a. Item 01: No. 1 injector
 - OK: Idling state varies.**

Q: Is the check result normal?

YES : Intermittent malfunction (Refer to GROUP 00 –How to Use Troubleshooting/Inspection Service Points [P.00-5](#)).

NO : Go to Step 2 .

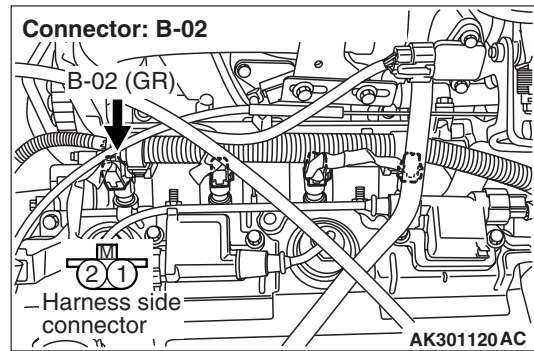
STEP 2. Connector check: B-02 No. 1 injector connector**Q: Is the check result normal?**

YES : Go to Step 3 .

NO : Repair or replace.

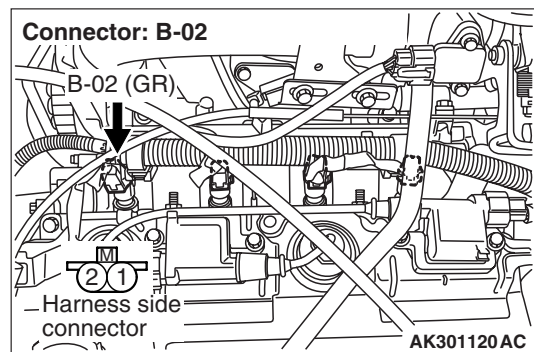
STEP 3. Perform resistance measurement at B-02 No. 1 injector connector.

- Disconnect connector, and measure at injector side.
- Resistance between terminal No. 1 and No. 2.

OK: 13 – 16 Ω

Q: Is the check result normal?

YES : Go to Step 4 .

NO : Replace No. 1 injector.

STEP 4. Perform voltage measurement at B-02 No. 1 injector connector.

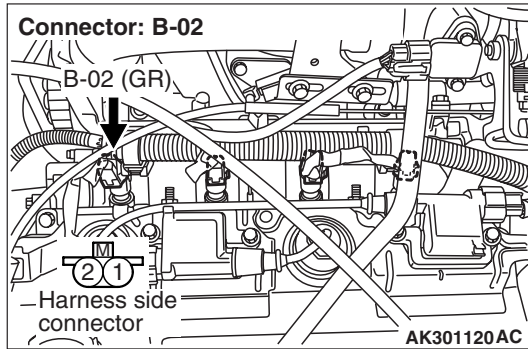

- Disconnect connector, and measure at harness side.
- Ignition switch: ON
- Voltage between terminal No. 1 and earth.

OK: System voltage

Q: Is the check result normal?

YES : Go to Step 6 .

NO : Go to Step 5 .

STEP 5. Connector check: B-16X engine control relay connector

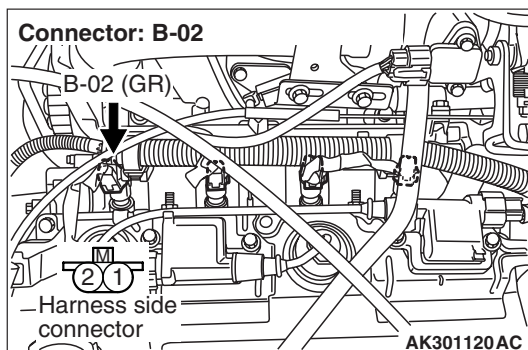
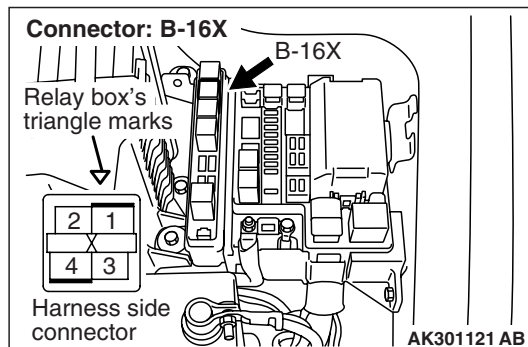

Q: Is the check result normal?

YES : Check and repair harness between B-16X (terminal No. 4) engine control relay connector and B-02 (terminal No. 1) No. 1 injector connector.

- Check power supply line for open/short circuit.

NO : Repair or replace.

STEP 6. Connector check: B-16X engine control relay connector

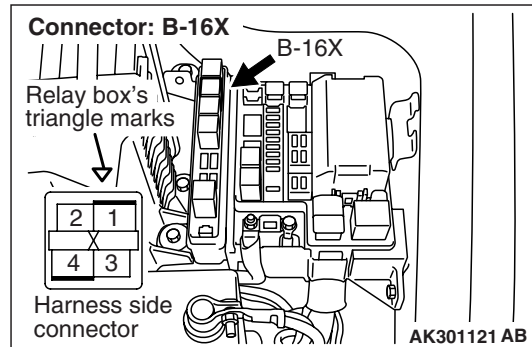

Q: Is the check result normal?

YES : Go to Step 7 .

NO : Repair or replace.

STEP 7. Check harness between B-16X (terminal No. 4) engine control relay connector and B-02 (terminal No. 1) No. 1 injector connector.

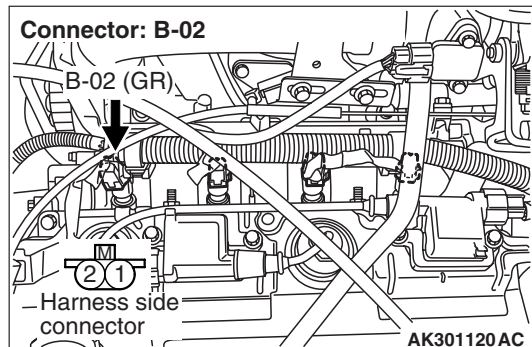
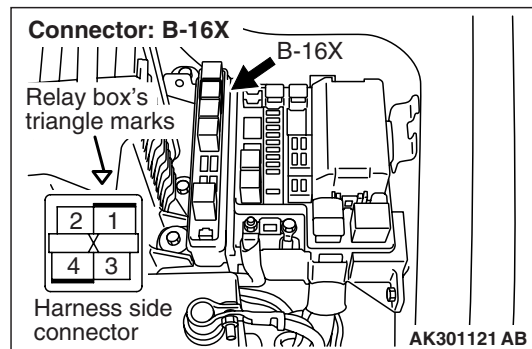

- Check power supply line for damage.

Q: Is the check result normal?

YES : Go to Step 8 .

NO : Repair.

**STEP 8. Connector check: C-123 engine-ECU
<M/T> connector or C-122 engine-A/T-ECU <A/T>
connector**

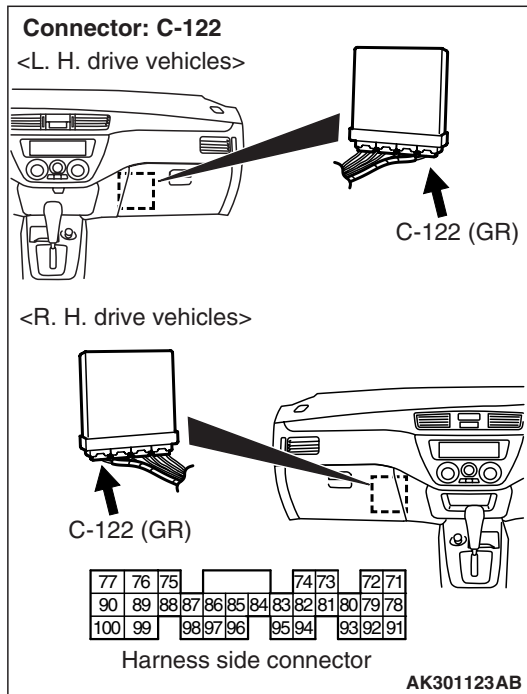
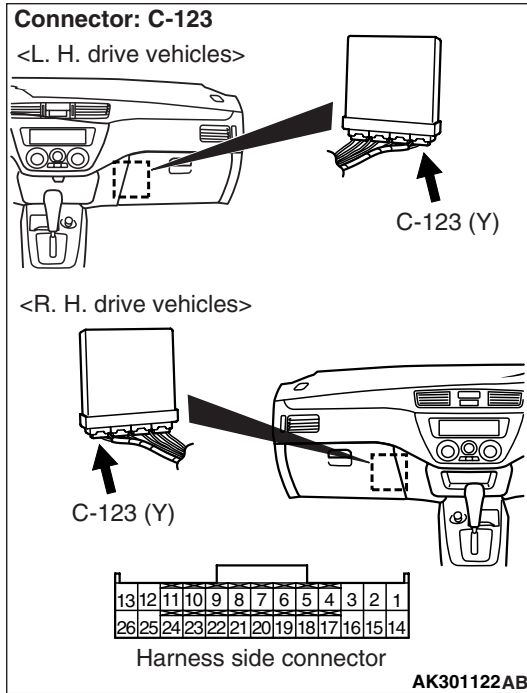

Q: Is the check result normal?

YES : Go to Step 9 .

NO : Repair or replace.

STEP 9. Check harness between B-02 (terminal No. 2) No.1 injector connector and C-123 (terminal No. 1) engine-ECU <M/T> connector or C-122 (terminal No. 1) engine-A/T-ECU <A/T> connector.

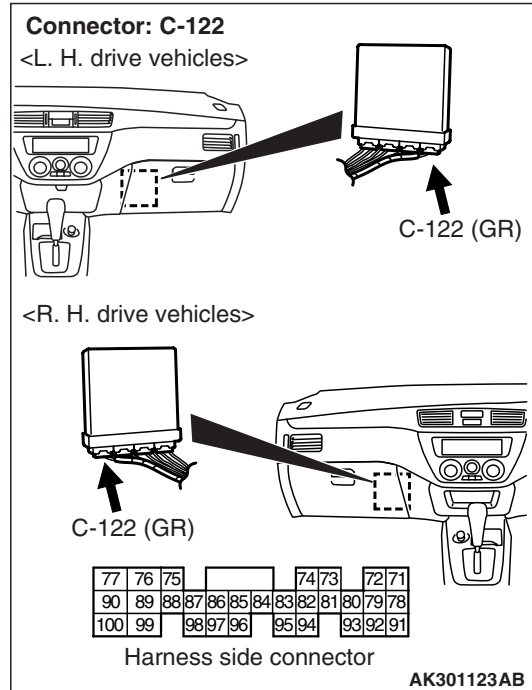
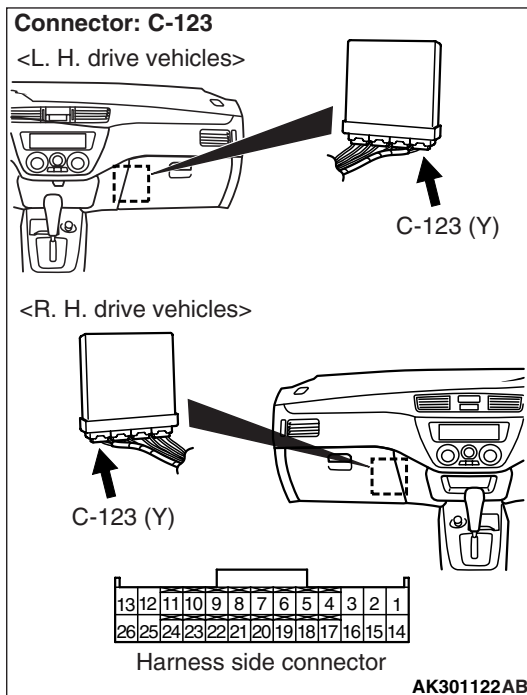
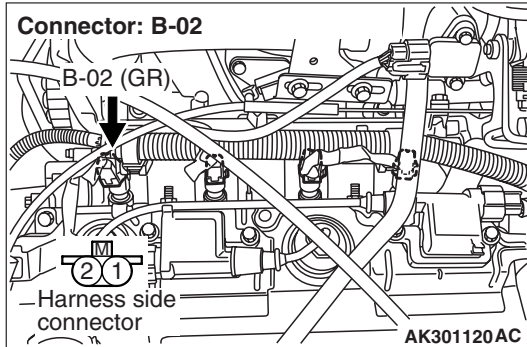

- Check output line for open/short circuit and damage.
- Q: Is the check result normal?**
YES : Go to Step 10 .
NO : Repair.

STEP 10. Perform signal wavepattern measurement at C-123 engine-ECU <M/T> connector or C-122 engine-A/T-ECU <A/T> connector (Using oscilloscope).

Q: Is the check result normal?

YES : Intermittent malfunction (Refer to GROUP 00 –How to Use Troubleshooting/Inspection Service Points P.00-5).

NO : Replace engine-ECU <M/T> or engine-A/T-ECU <A/T>.

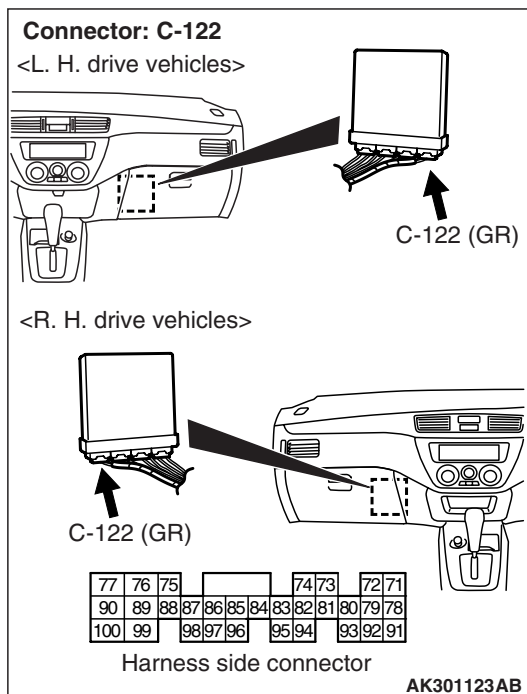
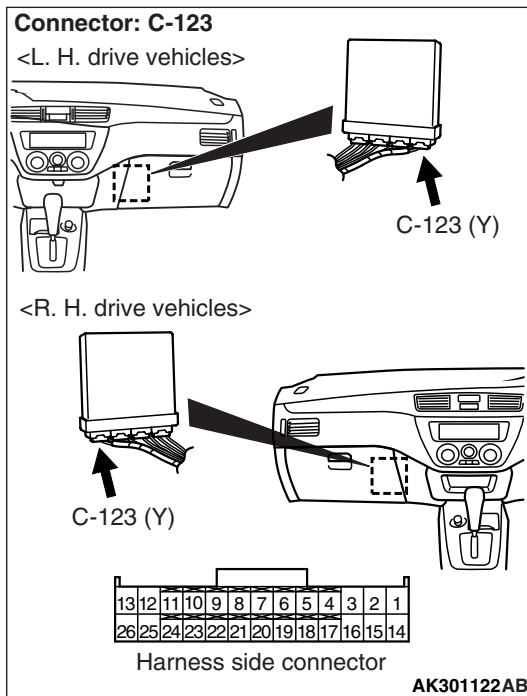

- Engine: Idling
- Transmission: Neutral <M/T> or P range <A/T>
- Voltage between terminal No. 1 and earth.

OK: Waveforms should be display on Inspection procedure using an oscilloscope (Refer to P.13A-391).

Code No. P0202: No. 2 Injector System

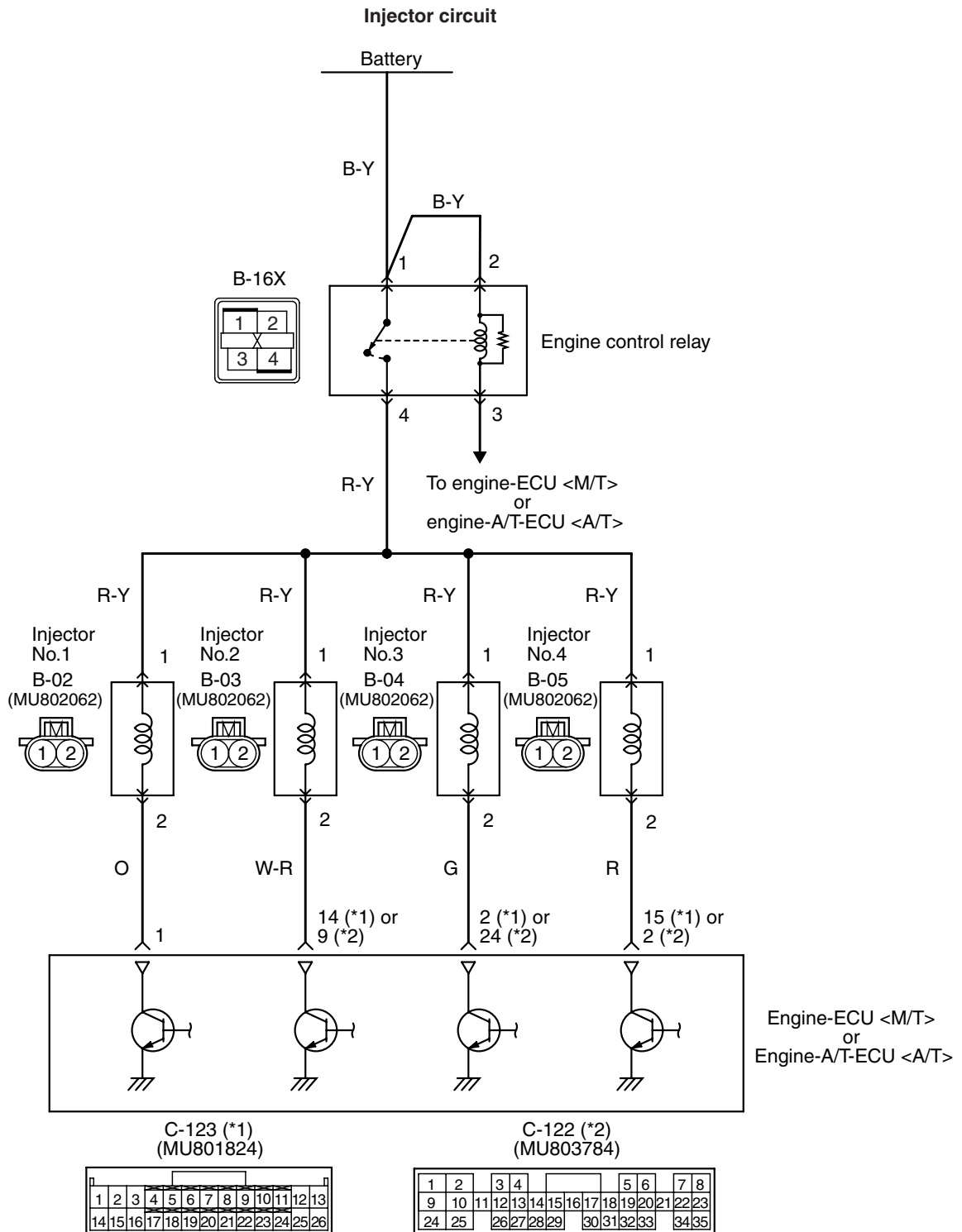

NOTE
*1: M/T
*2: A/T

Wire colour code
B: Black LG: Light green G: Green L: Blue W: White Y: Yellow SB: Sky blue BR: Brown O: Orange GR: Gray
R: Red P: Pink V: Violet

OPERATION

- Power is supplied to the injector (terminal No. 1) from the engine control relay (terminal No. 4).
- The engine-ECU (terminal No. 14) <M/T> or engine-A/T-ECU (terminal No. 9) <A/T> makes the power transistor in the unit be in "ON" position, and that makes currents go on the injector (terminal No. 2).

FUNCTION

- The engine-ECU <M/T> or engine-A/T-ECU <A/T> controls the power supply interval of the injector.
- The fuel injection amount of the injector depends on the power supply interval.

TROUBLE JUDGMENT**Check Conditions**

- The engine speed is 50 – 1,000 r/mim.
- The throttle position sensor output voltage 1.15 V or less.
- Injector not in forced drive (actuator test) mode

Judgment Criterion

- No surge voltage of the injector coil is detected for 2 seconds.

PROBABLE CAUSE

- Failed No. 2 injector
- Open/short circuit in No. 2 injector circuit or loose connector contact
- Failed engine-ECU <M/T>
- Failed engine-A/T-ECU <A/T>

DIAGNOSIS PROCEDURE**STEP 1. M.U.T.-II/III actuator test**

- Refer to actuator test reference table [P.13A-383](#).
 - a. Item 02: No. 2 injector
 - OK: Idling state varies.**

Q: Is the check result normal?

YES : Intermittent malfunction (Refer to GROUP 00 –How to Use Troubleshooting/Inspection Service Points [P.00-5](#)).

NO : Go to Step 2 .

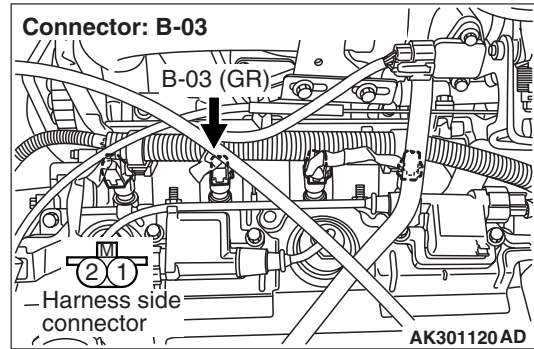
STEP 2. Connector check: B-03 No. 2 injector connector**Q: Is the check result normal?**

YES : Go to Step 3 .

NO : Repair or replace.

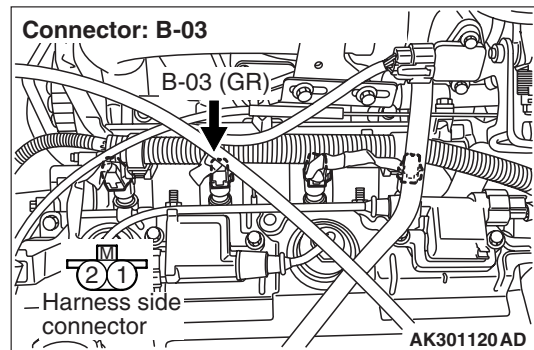
STEP 3. Perform resistance measurement at B-03 No. 2 injector connector.

- Disconnect connector, and measure at injector side.
- Resistance between terminal No. 1 and No. 2.

OK: 13 – 16 Ω

Q: Is the check result normal?

YES : Go to Step 4 .

NO : Replace No. 2 injector.

STEP 4. Perform voltage measurement at B-03 No. 2 injector connector.

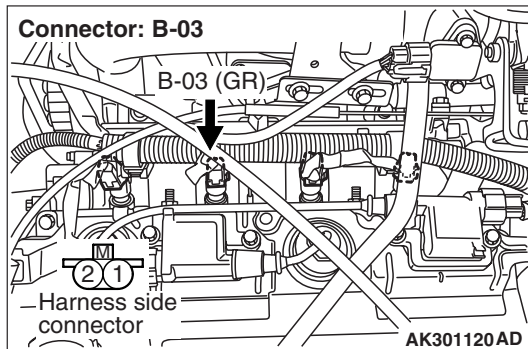

- Disconnect connector, and measure at harness side.
- Ignition switch: ON
- Voltage between terminal No. 1 and earth.

OK: System voltage

Q: Is the check result normal?

YES : Go to Step 6 .

NO : Go to Step 5 .

STEP 5. Connector check: B-16X engine control relay connector

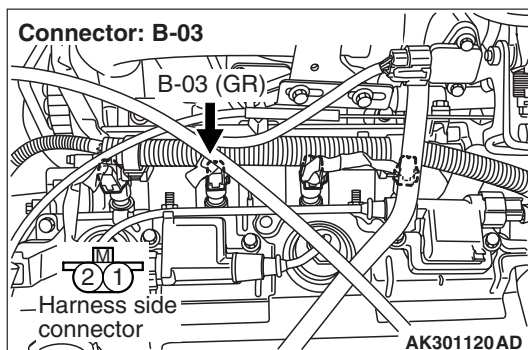
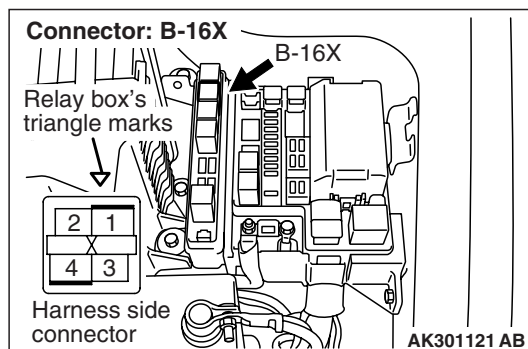

Q: Is the check result normal?

YES : Check and repair harness between B-16X (terminal No. 4) engine control relay connector and B-03 (terminal No. 1) No. 2 injector connector.

- Check power supply line for open/short circuit and damage.

NO : Repair or replace.

STEP 6. Connector check: B-16X engine control relay connector

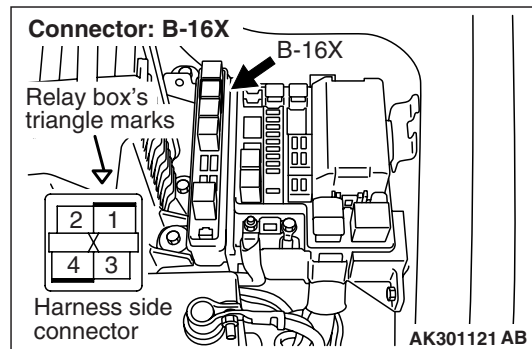

Q: Is the check result normal?

YES : Go to Step 7 .

NO : Repair or replace.

STEP 7. Check harness between B-16X (terminal No. 4) engine control relay connector and B-03 (terminal No. 1) No. 2 injector connector.

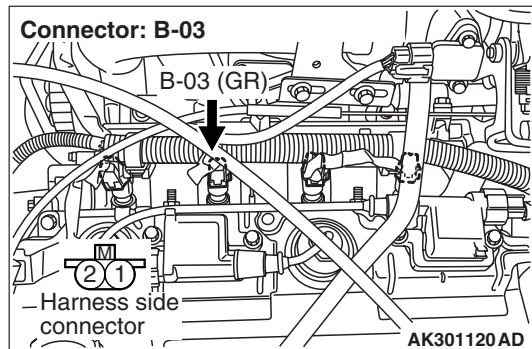
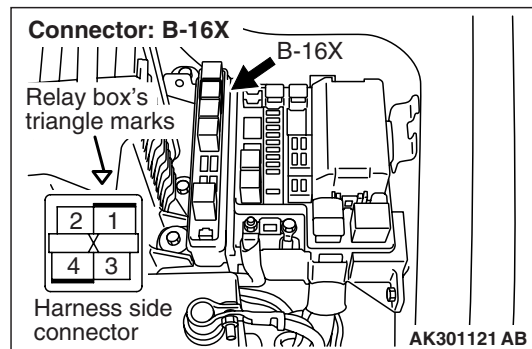

- Check power supply line for damage.

Q: Is the check result normal?

YES : Go to Step 8 .

NO : Repair.

STEP 8. Connector check: C-123 engine-ECU <M/T> connector or C-122 engine-A/T-ECU <A/T> connector

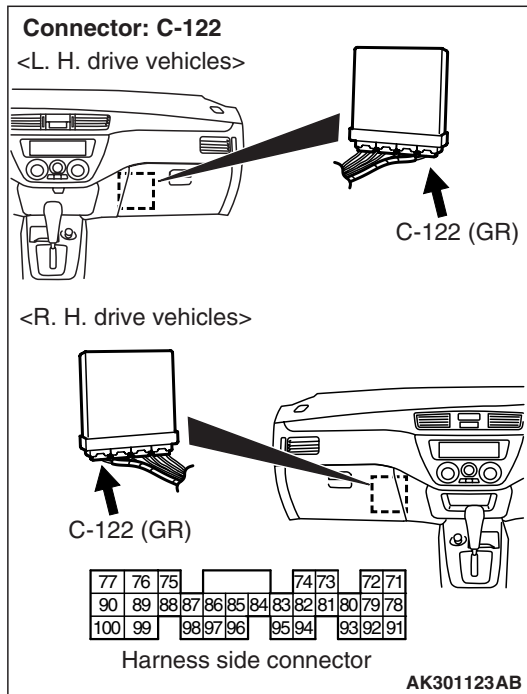
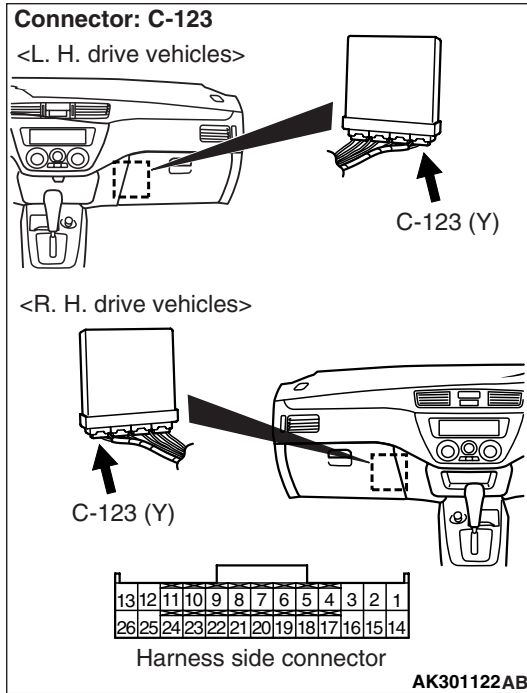

Q: Is the check result normal?

YES : Go to Step 9 .

NO : Repair or replace.

STEP 9. Check harness between B-03 (terminal No. 2) No. 2 injector connector and C-123 (terminal No. 14) engine-ECU <M/T> connector or C-122 (terminal No. 9) engine-A/T-ECU <A/T> connector.

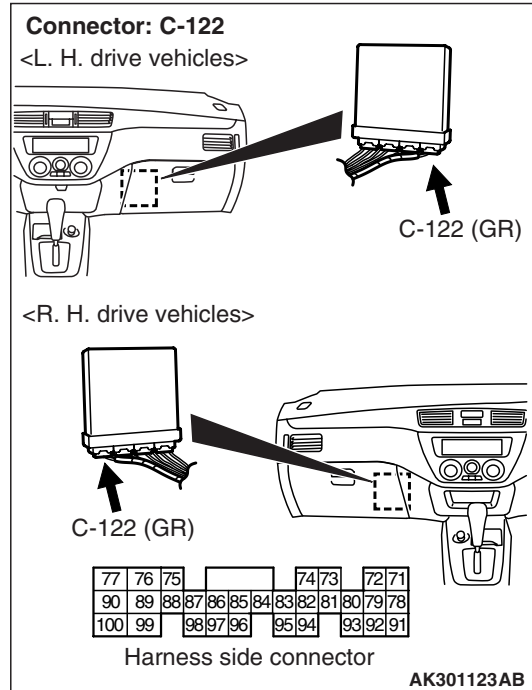
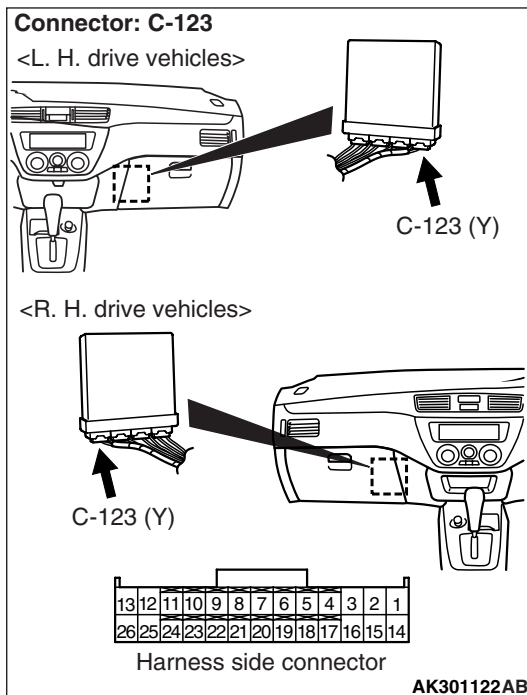
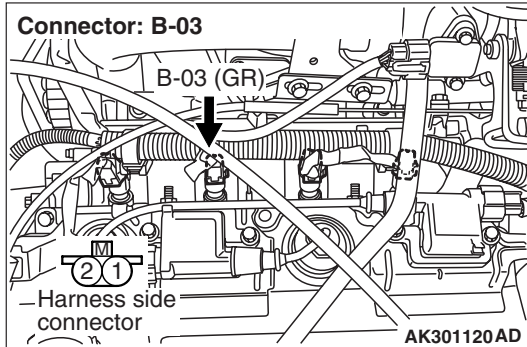

- Check output line for open/short circuit and damage.
- Q: Is the check result normal?**
YES : Go to Step 10 .
NO : Repair.

STEP 10. Perform signal wavepattern measurement at C-123 engine-ECU <M/T> connector or C-122 engine-A/T-ECU <A/T> connector (Using oscilloscope).

Q: Is the check result normal?

YES : Intermittent malfunction (Refer to GROUP 00 –How to Use Troubleshooting/Inspection Service Points P.00-5).

NO : Replace engine-ECU <M/T> or engine-A/T-ECU <A/T>.

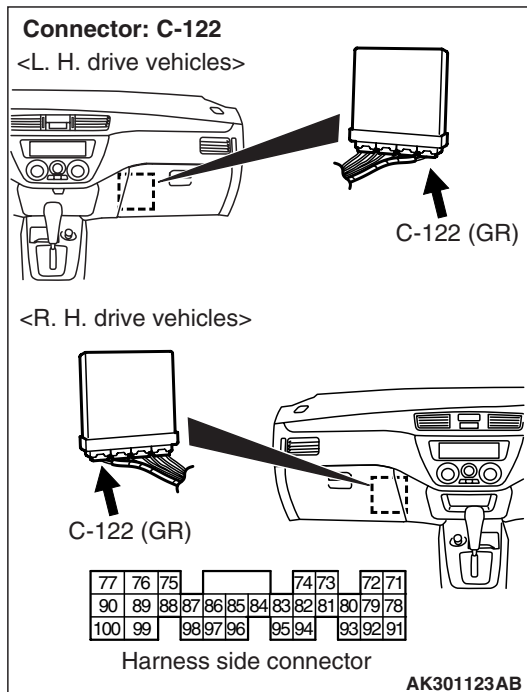
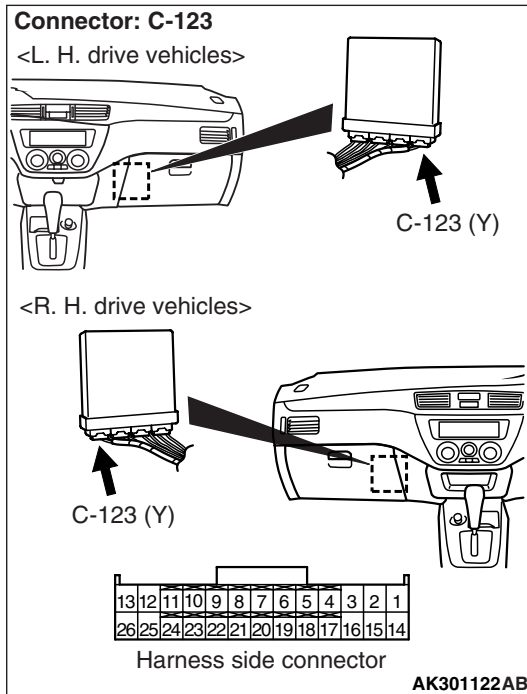

- Engine: Idling
- Transmission: Neutral <M/T> or P range <A/T>
- Voltage between terminal No. 14 <M/T> or terminal No. 9 <A/T> and earth.

OK: Waveform should be display on Inspection procedure using an oscilloscope (Refer to P.13A-391).

Code No. P0203: No. 3 Injector System

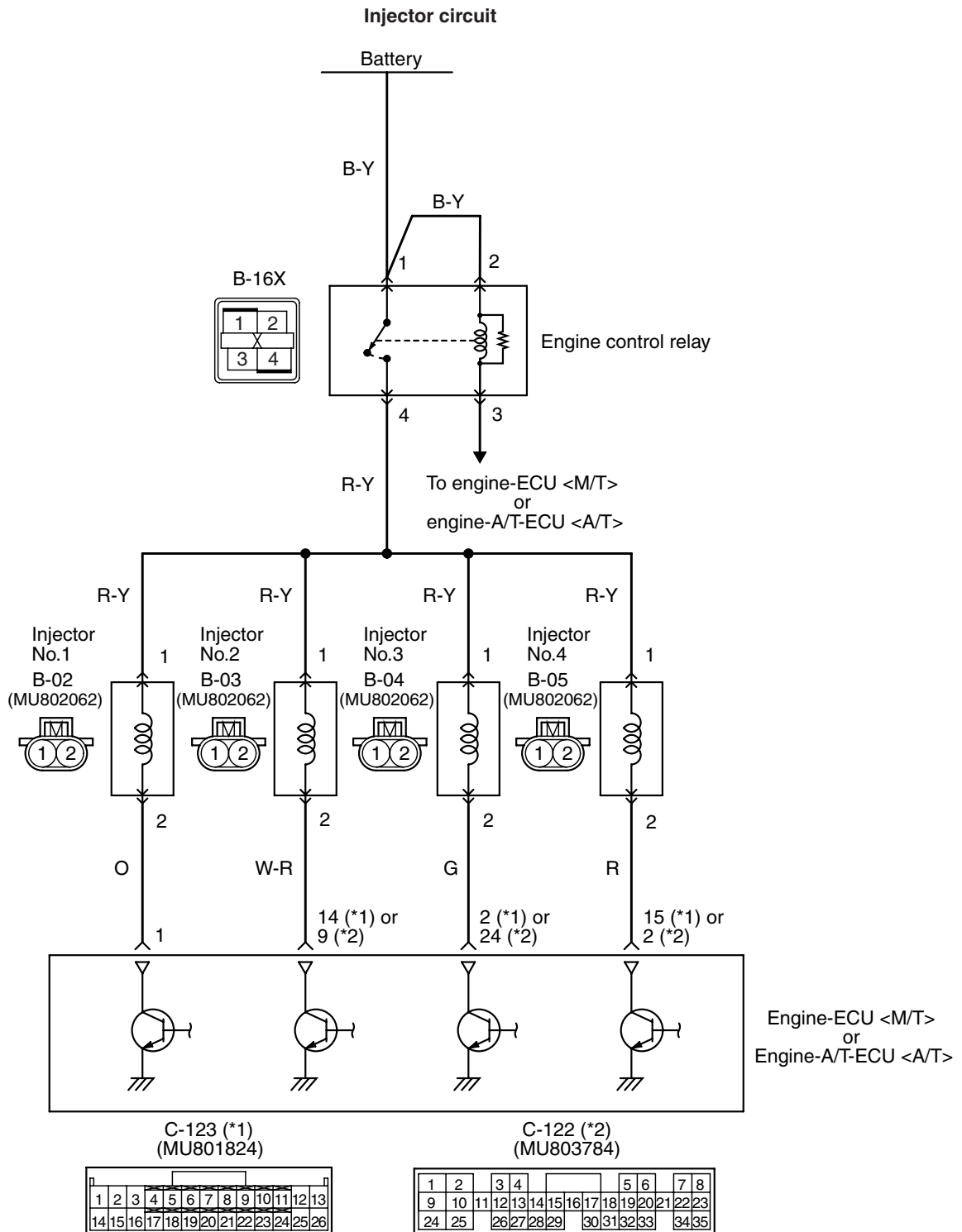

NOTE
*1: M/T
*2: A/T

Wire colour code
B: Black LG: Light green G: Green L: Blue W: White Y: Yellow SB: Sky blue BR: Brown O: Orange GR: Gray
R: Red P: Pink V: Violet

OPERATION

- Power is supplied to the injector (terminal No. 1) from the engine control relay (terminal No. 4).
- The engine-ECU (terminal No. 2) <M/T> or engine-A/T-ECU (terminal No. 24) <A/T> makes the power transistor in the unit be in "ON" position, and that makes currents go on the injector (terminal No. 2).

FUNCTION

- The engine-ECU <M/T> or engine-A/T-ECU <A/T> controls the power supply interval of the injector.
- The fuel injection amount of the injector depends on the power supply interval.

TROUBLE JUDGMENT**Check Conditions**

- The engine speed is 50 – 1,000 r/mim.
- The throttle position sensor output voltage is 1.15 V or less.
- Injector not in forced drive (actuator test) mode

Judgment Criterion

- No surge voltage of the injector coil is detected for 2 seconds.

PROBABLE CAUSE

- Failed No. 3 injector
- Open/short circuit in No. 3 injector circuit or loose connector contact
- Failed engine-ECU <M/T>
- Failed engine-A/T-ECU <A/T>

DIAGNOSIS PROCEDURE**STEP 1. M.U.T.-II/III actuator test**

- Refer to actuator test reference table [P.13A-383](#).
 - a. Item 03: No. 3 injector
 - OK: Idling state varies.**

Q: Is the check result normal?

YES : Intermittent malfunction (Refer to GROUP 00 –How to Use Troubleshooting/Inspection Service Points [P.00-5](#)).

NO : Go to Step 2 .

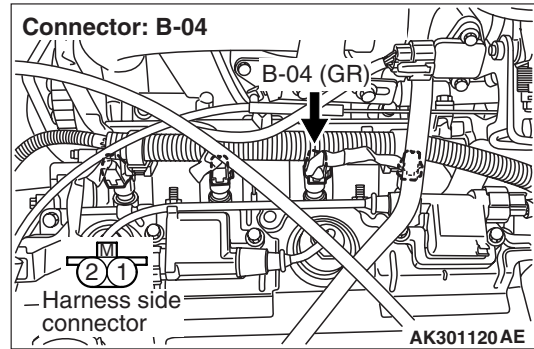
STEP 2. Connector check: B-04 No. 3 injector connector**Q: Is the check result normal?**

YES : Go to Step 3 .

NO : Repair or replace.

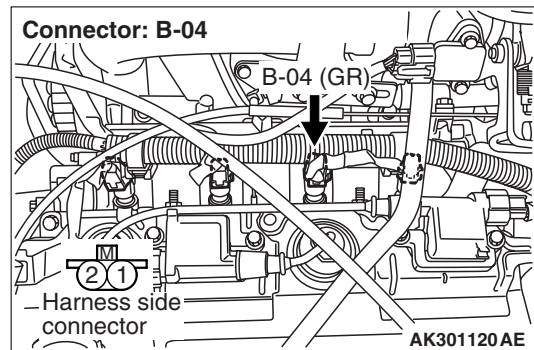
STEP 3. Perform resistance measurement at B-04 No. 3 injector connector.

- Disconnect connector, and measure at injector side.
- Resistance between terminal No. 1 and No. 2.

OK: 13 – 16 Ω

Q: Is the check result normal?

YES : Go to Step 4 .

NO : Replace No. 3 injector.

STEP 4. Perform voltage measurement at B-04 No. 3 injector connector.

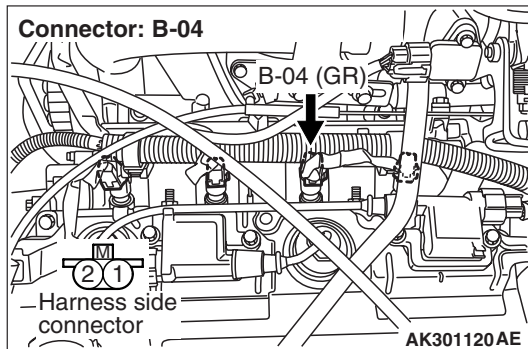

- Disconnect connector, and measure at harness side.
- Ignition switch: ON
- Voltage between terminal No. 1 and earth.

OK: System voltage

Q: Is the check result normal?

YES : Go to Step 6 .

NO : Go to Step 5 .

STEP 5. Connector check: B-16X engine control relay connector

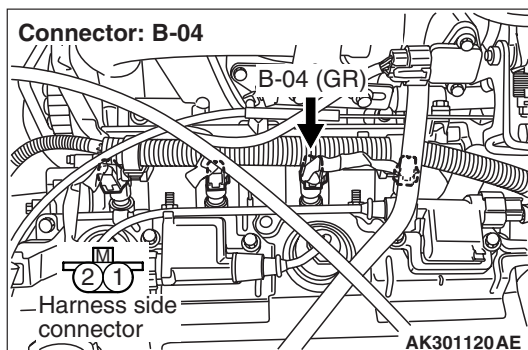
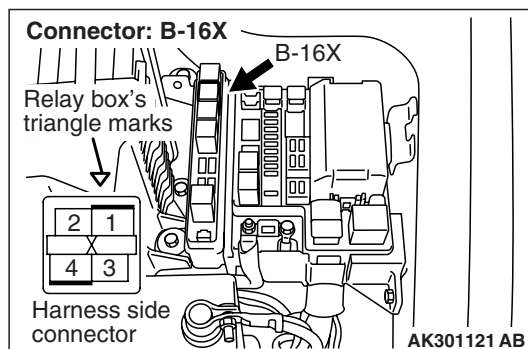

Q: Is the check result normal?

YES : Check and repair harness between B-16X (terminal No. 4) engine control relay connector and B-04 (terminal No. 1) No. 3 injector connector.

- Check power supply line for open/short circuit.

NO : Repair or replace.

STEP 6. Connector check: B-16X engine control relay connector

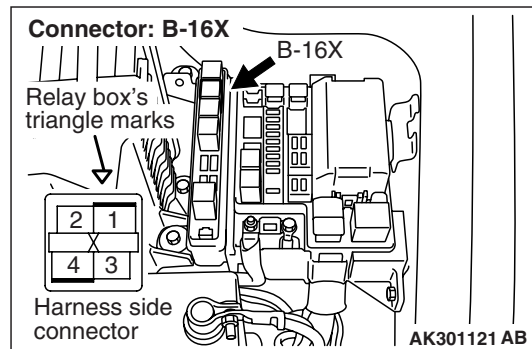

Q: Is the check result normal?

YES : Go to Step 7 .

NO : Repair or replace.

STEP 7. Check harness between B-16X (terminal No. 4) engine control relay connector and B-04 (terminal No. 1) No. 3 injector connector.

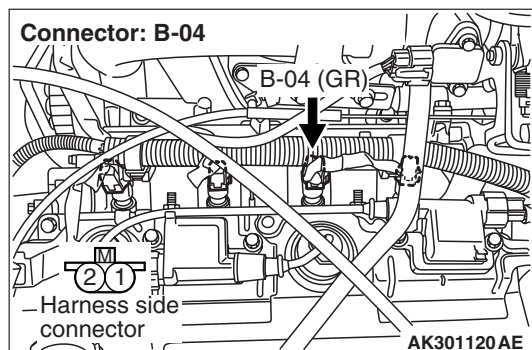
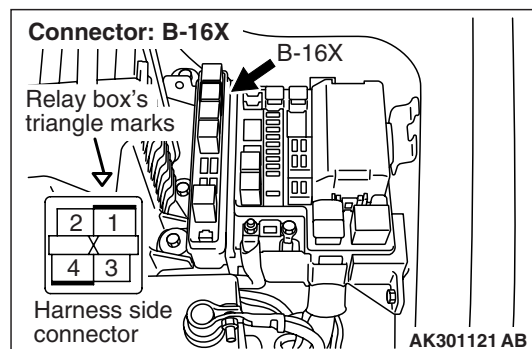

- Check power supply line for damage.

Q: Is the check result normal?

YES : Go to Step 8 .

NO : Repair.

STEP 8. Connector check: C-123 engine-ECU <M/T> connector or C-122 engine-A/T-ECU <A/T> connector

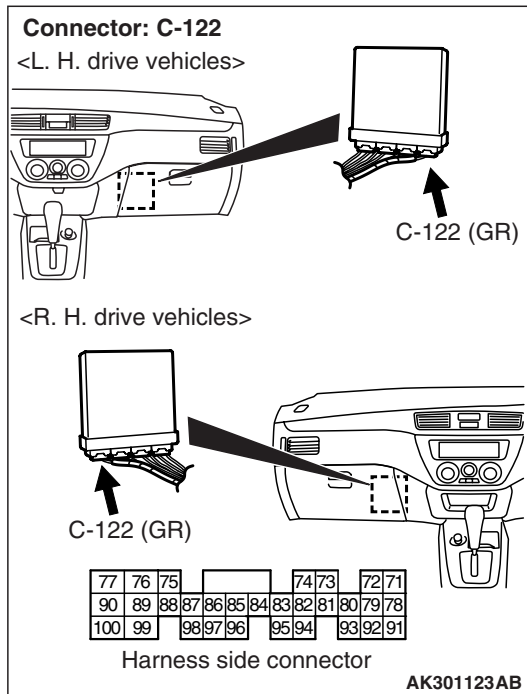
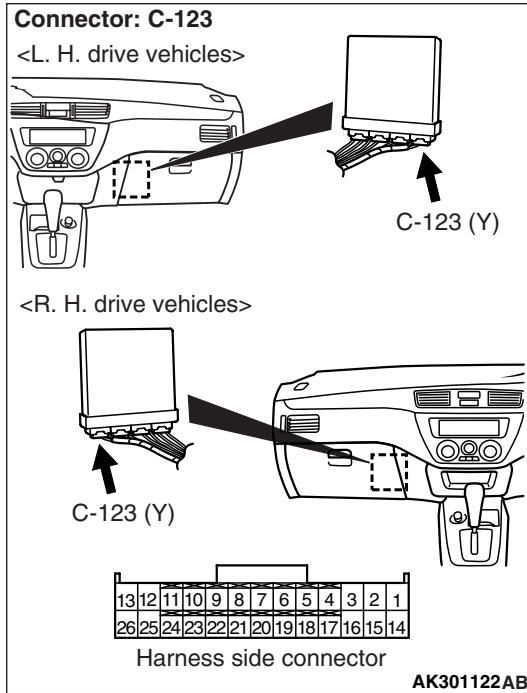

Q: Is the check result normal?

YES : Go to Step 9 .

NO : Repair or replace.

STEP 9. Check harness between B-04 (terminal No. 2) No. 3 injector connector and C-123 (terminal No. 2) engine-ECU <M/T> connector or C-122 (terminal No. 24) engine-A/T-ECU <A/T> connector.

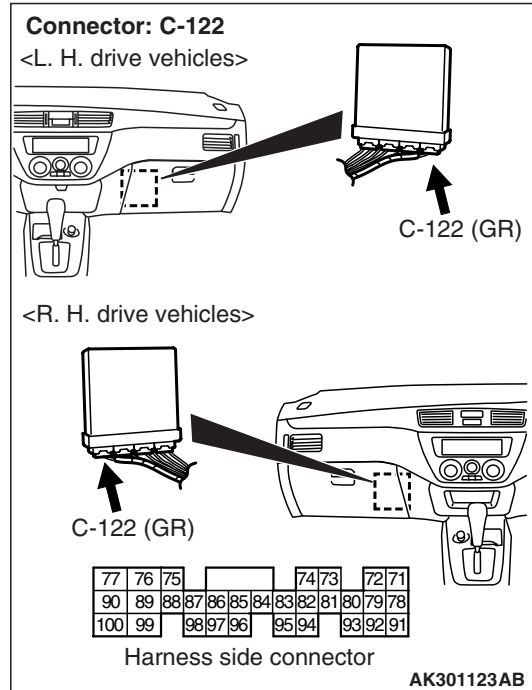
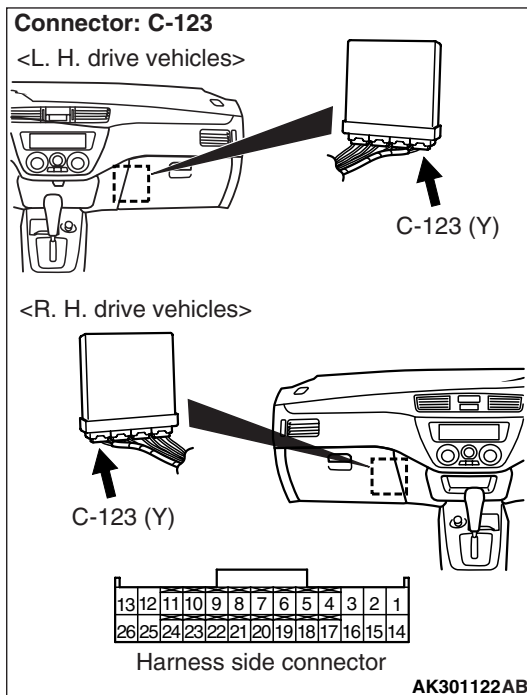
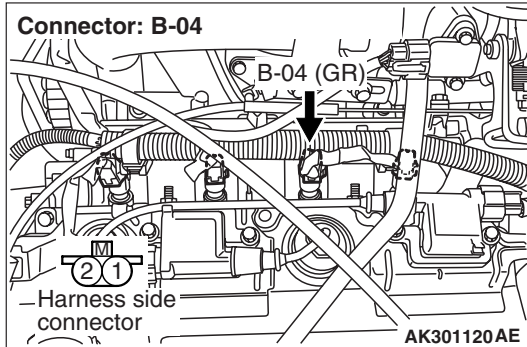

- Check output line for open/short circuit and damage.
- Q: Is the check result normal?**
YES : Go to Step 10 .
NO : Repair.

STEP 10. Perform signal wavepattern measurement at C-123 engine-ECU <M/T> connector or C-122 engine-A/T-ECU <A/T> connector (Using oscilloscope).

Q: Is the check result normal?

YES : Intermittent malfunction (Refer to GROUP 00 –How to Use Troubleshooting/Inspection Service Points P.00-5).

NO : Replace engine-ECU <M/T> or engine-A/T-ECU <A/T>.

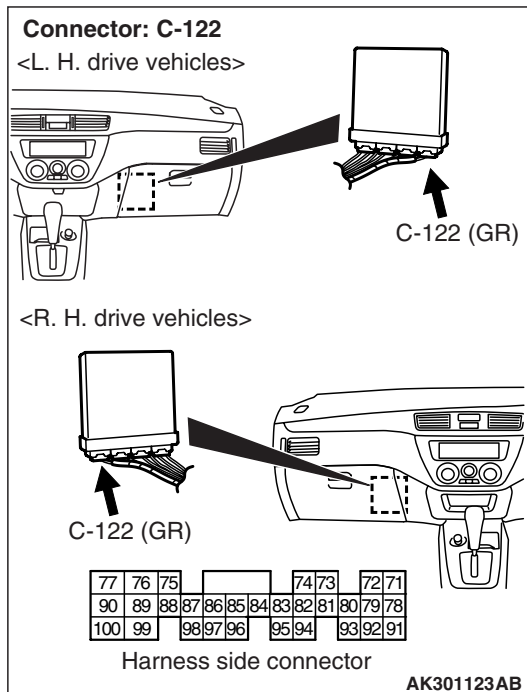
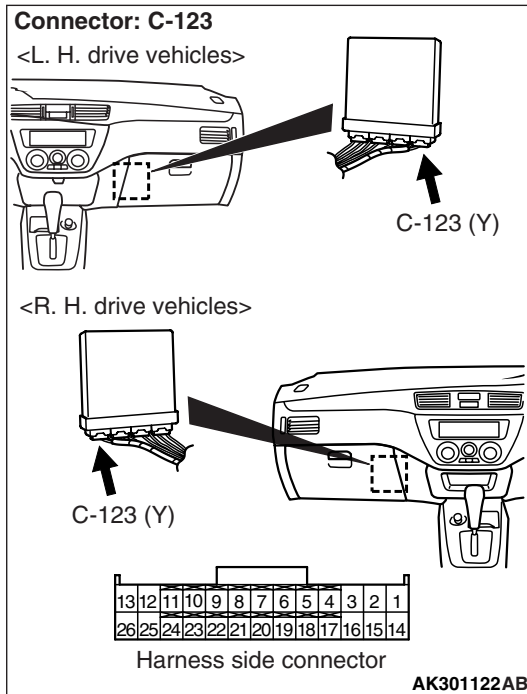

- Engine: Idling
- Transmission: Neutral <M/T> or P range <A/T>
- Voltage between terminal No. 2 <M/T> or terminal No. 24 <A/T> and earth.

OK: Waveform should be displayed on Inspection procedure using an oscilloscope (Refer to P.13A-391).

Code No. P0204: No. 4 Injector System

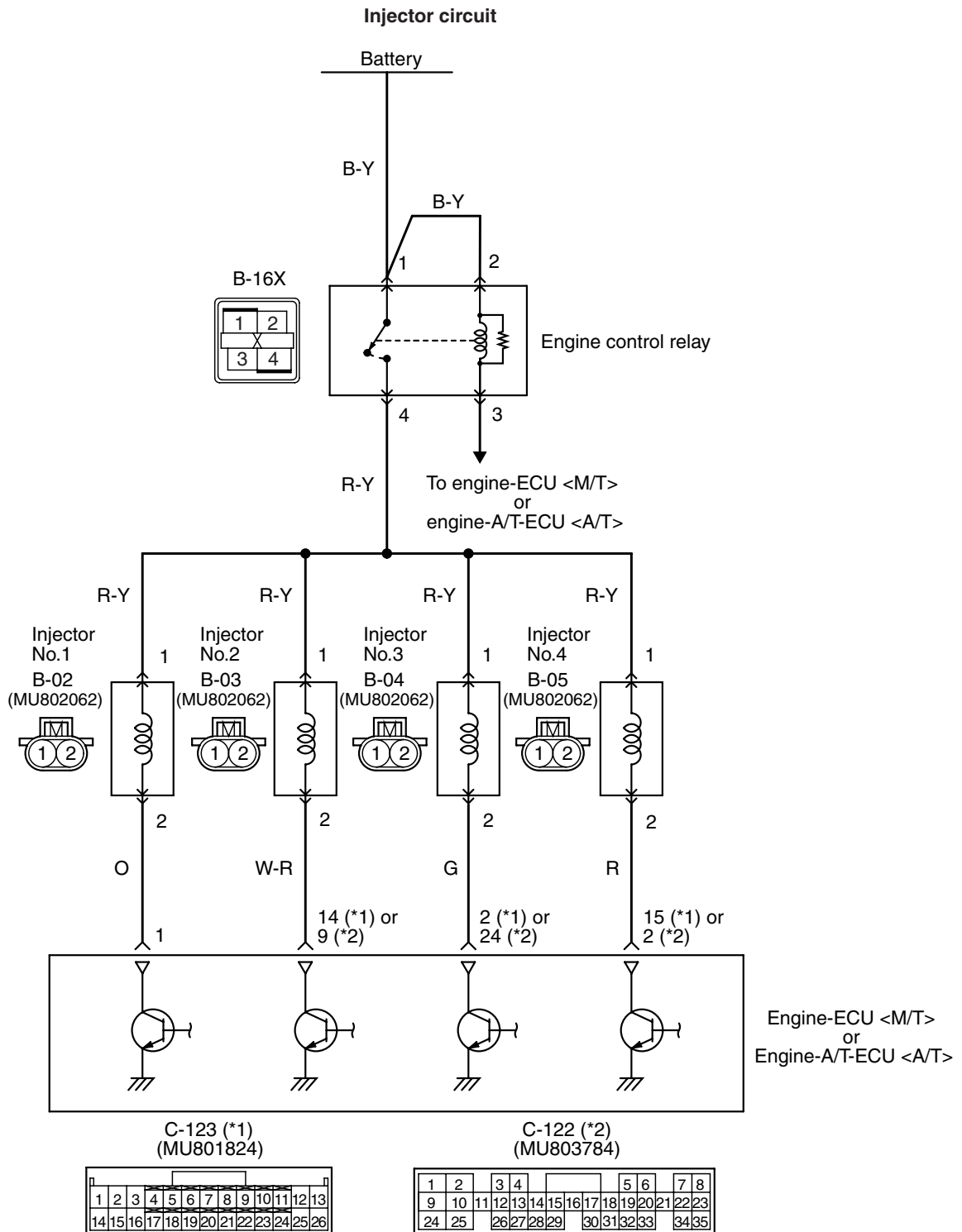

NOTE
*1: M/T
*2: A/T

Wire colour code
B: Black LG: Light green G: Green L: Blue W: White Y: Yellow SB: Sky blue BR: Brown O: Orange GR: Gray
R: Red P: Pink V: Violet

OPERATION

- Power is supplied to the injector (terminal No. 1) from the engine control relay (terminal No. 4).
- The engine-ECU (terminal No. 15) <M/T> or engine-A/T-ECU (terminal No. 2) <A/T> makes the power transistor in the unit be in "ON" position, and that makes currents go on the injector (terminal No. 2).

FUNCTION

- The engine-ECU <M/T> or engine-A/T-ECU <A/T> controls the power supply interval of the injector.
- The fuel injection amount of the injector depends on the power supply interval.

TROUBLE JUDGMENT**Check Conditions**

- The engine speed is 50 – 1,000 r/mim.
- The throttle position sensor output 1.15 V or less.
- Injector not in forced drive (actuator test) mode

Judgment Criterion

- No surge voltage of the injector coil is detected for 2 seconds

PROBABLE CAUSE

- Failed No. 4 injector
- Open/short circuit in No. 4 injector circuit or loose connector contact
- Failed engine-ECU <M/T>
- Failed engine-A/T-ECU <A/T>

DIAGNOSIS PROCEDURE**STEP 1. M.U.T.-II/III actuator test**

- Refer to actuator test reference table [P.13A-383](#).
 - a. Item 04: No. 4 injector

OK: Idling state varies.

Q: Is the check result normal?

YES : Intermittent malfunction (Refer to GROUP 00 –How to Use Troubleshooting/Inspection Service Points [P.00-5](#)).

NO : Go to Step 2 .

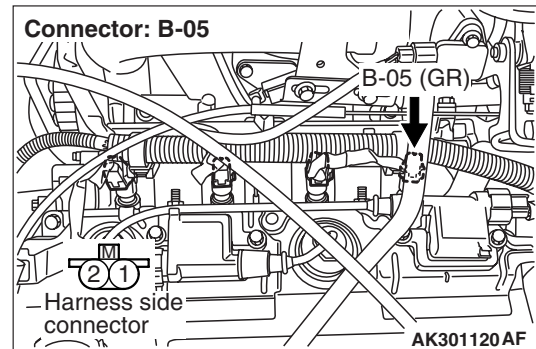
STEP 2. Connector check: B-05 No. 4 injector connector**Q: Is the check result normal?**

YES : Go to Step 3 .

NO : Repair or replace.

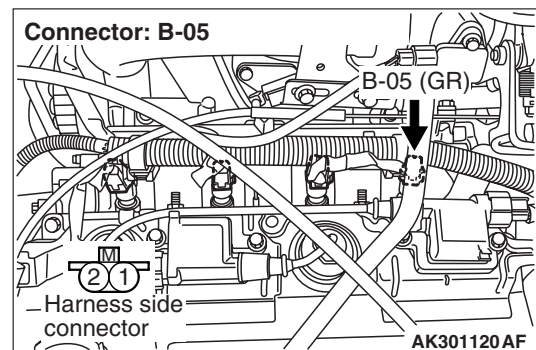
STEP 3. Perform resistance measurement at B-05 No. 4 injector connector.

- Disconnect connector, and measure at injector side.
- Resistance between terminal No. 1 and No. 2.

OK: 13 – 16 Ω

Q: Is the check result normal?

YES : Go to Step 4 .

NO : Replace No. 4 injector.

STEP 4. Perform voltage measurement at B-05 No. 4 injector connector.

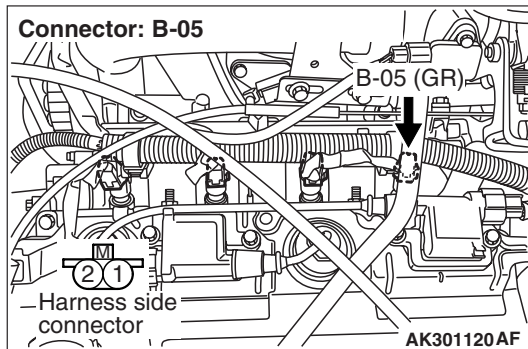

- Disconnect connector, and measure at harness side.
- Ignition switch: ON
- Voltage between terminal No. 1 and earth.

OK: System voltage

Q: Is the check result normal?

YES : Go to Step 6 .

NO : Go to Step 5 .

STEP 5. Connector check: B-16X engine control relay connector

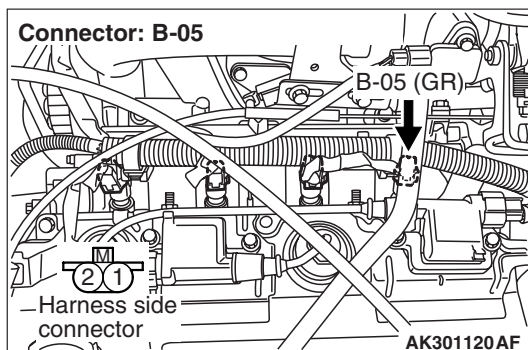
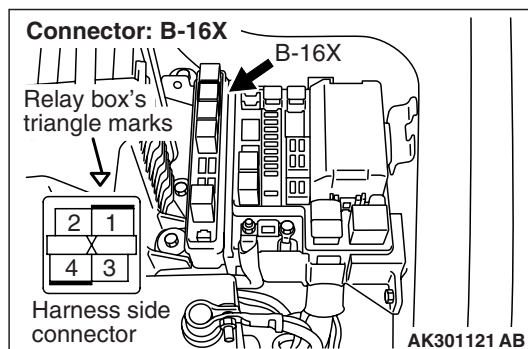

Q: Is the check result normal?

YES : Check and repair harness between B-16X (terminal No. 1) engine control relay connector and B-05 (terminal No. 1) No. 4 injector connector.

- Check power supply line for open/short circuit and damage.

NO : Repair or replace.

STEP 6. Connector check: B-16X engine control relay connector

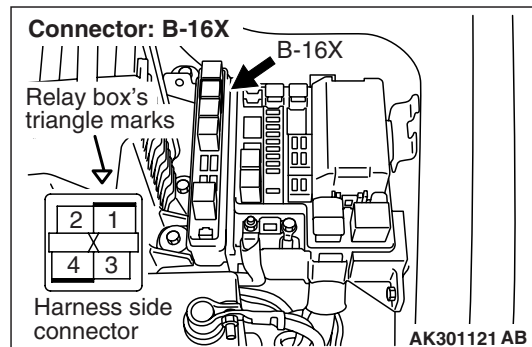

Q: Is the check result normal?

YES : Go to Step 7 .

NO : Repair or replace.

STEP 7. Check harness between B-16X (terminal No. 4) engine control relay connector and B-05 (terminal No. 1) No. 4 injector connector.

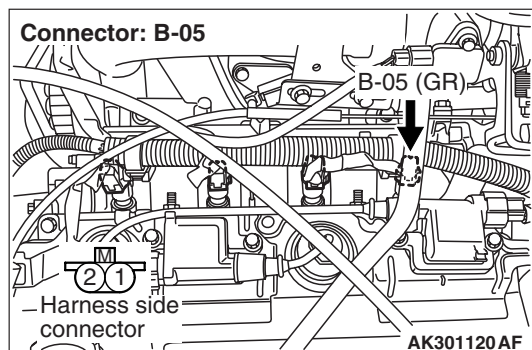
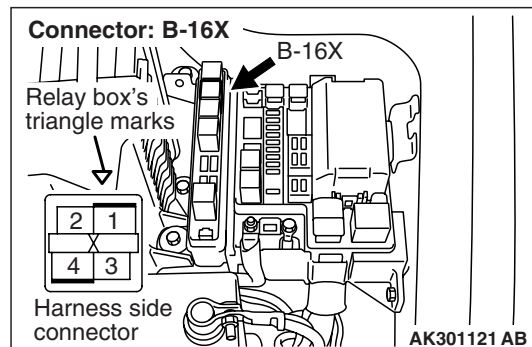

- Check power supply line for damage.

Q: Is the check result normal?

YES : Go to Step 8 .

NO : Repair.

STEP 8. Connector check: C-123 engine-ECU <M/T> connector or C-122 engine-A/T-ECU <A/T> connector

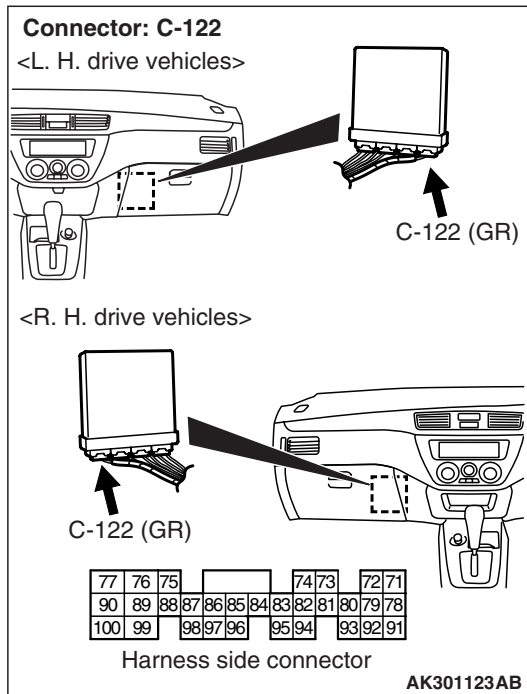
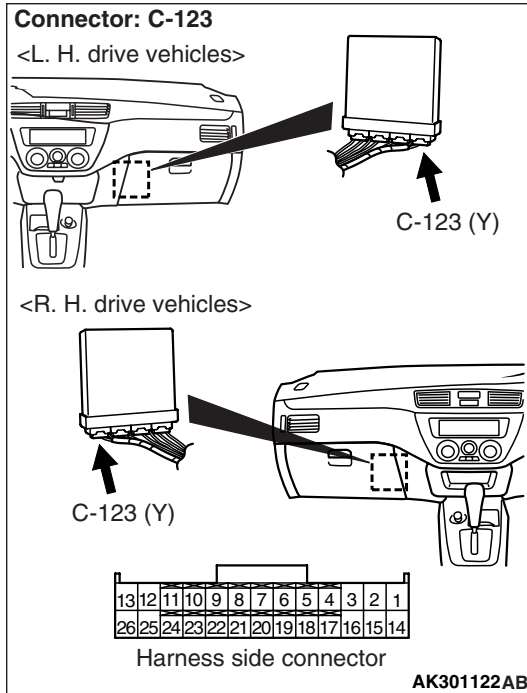

Q: Is the check result normal?

YES : Go to Step 9 .

NO : Repair or replace.

STEP 9. Check harness between B-05 (terminal No. 2) No. 4 injector connector and C-123 (terminal No. 15) engine-ECU <M/T> connector or C-122 (terminal No. 2) engine-A/T-ECU <A/T> connector.

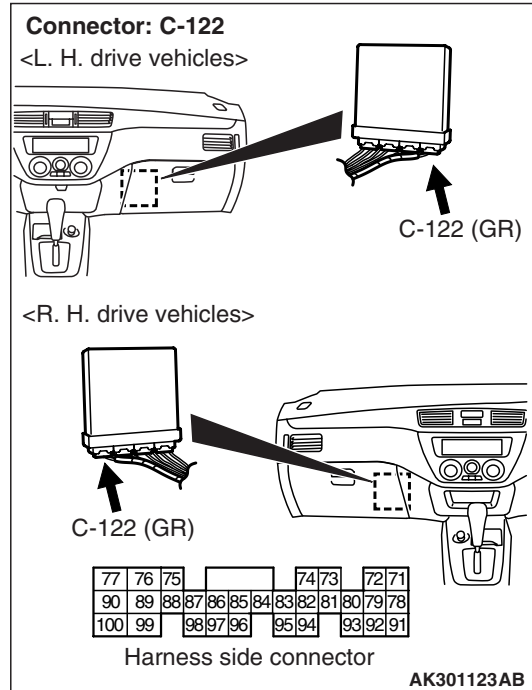
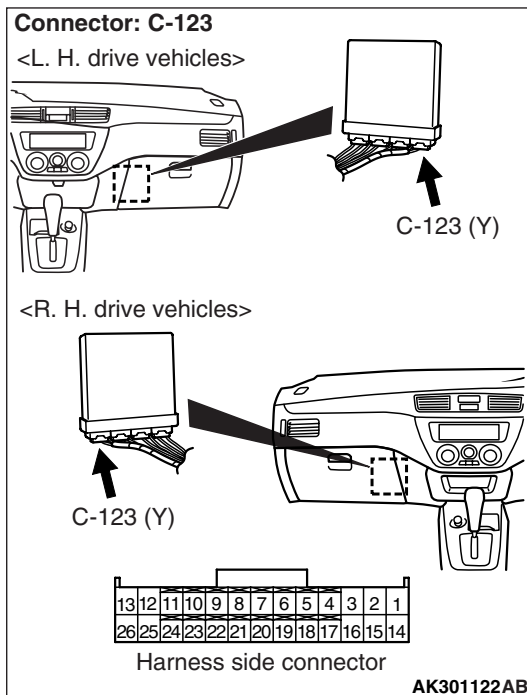
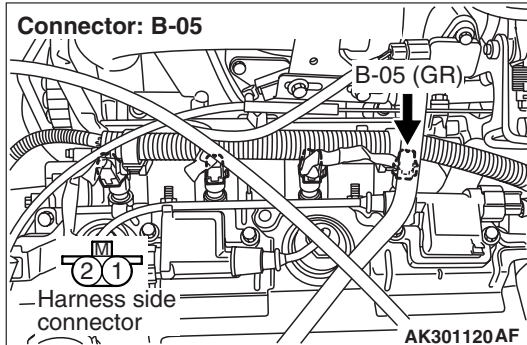

- Check output line for open/short circuit and damage.
- Q: Is the check result normal?**
YES : Go to Step 10 .
NO : Repair.

STEP 10. Perform signal wavepattern measurement at C-123 engine-ECU <M/T> connector or C-122 engine-A/T-ECU <A/T> connector (Using oscilloscope).

Q: Is the check result normal?

YES : Intermittent malfunction (Refer to GROUP 00 –How to Use Troubleshooting/Inspection Service Points P.00-5).

NO : Replace engine-ECU <M/T> or engine-A/T-ECU <A/T>.

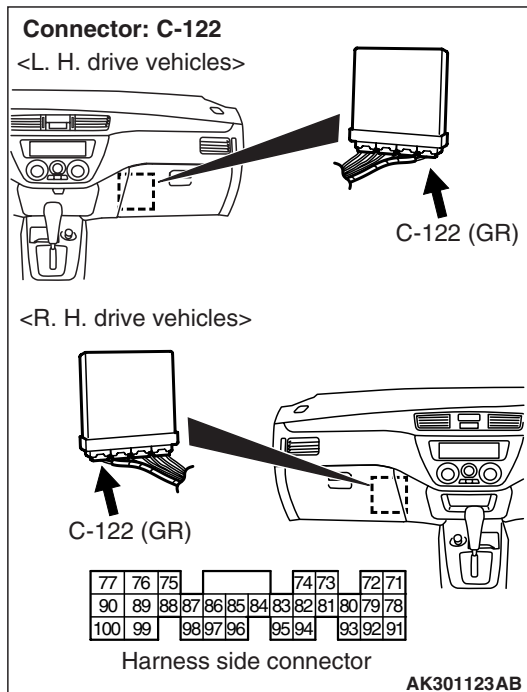
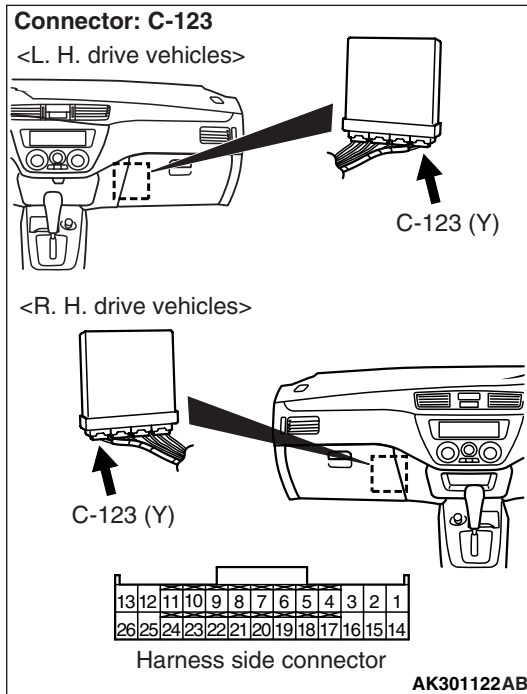

- Engine: Idling
- Transmission: Neutral <M/T> or P range <A/T>
- Voltage between terminal No. 15 <M/T> or terminal No. 2 <A/T> and earth.

OK: Waveform should be displayed on Inspection procedure using an oscilloscope (Refer to P.13A-391).

Code No. P0300: Random Cylinder Misfire Detected

OPERATION

- Refer to P0201 injector circuit [P.13A-115](#).
- Refer to P0202 injector circuit [P.13A-121](#).
- Refer to P0203 injector circuit [P.13A-127](#).
- Refer to P0204 injector circuit [P.13A-133](#).

FUNCTION

- If a misfire occurs while the engine is running, the engine speed changes for an instant.
- The engine-ECU <M/T> or engine-A/T-ECU <A/T> checks for such changes in engine speed.

TROUBLE JUDGMENT

Check Conditions

- 5 seconds later after the engine has started up.
- The engine speed is 500 – 4,500 r/min.
- The engine coolant temperature is – 10° C or higher.
- The intake air temperature is – 10° C or higher.
- The barometric pressure is 72 kPa or more.
- The volumetric efficiency is 30 – 60%.
- The adaptive learning has been completed with the vane that generates the crankshaft position signals.
- During the engine operation except the shift change or low speed driving and rapid acceleration and deceleration, also intermittent operation of air compressor (A/C: within the 3 seconds after changing to ON from OFF or to OFF from ON).
- The throttle deviation is within the range of –0.059 V/10ms to 0.059 V/10ms.

Judgment Criteria

- The number of misfiring (in the catalyst temperature of above 950° C) is beyond the specified number (of 7.3% on more than the two cylinders) with the engine speed of 200 r/min.

or

- The number of misfiring (that is 1.5 times the emission standard limit) is beyond the specified number (of 2% on more than the two cylinders) with the engine speed of 1000 r/min.

PROBABLE CAUSE

- Ignition system related part(s) failed
- Failed crank angle sensor
- Incorrect air-fuel ratio

- Low compression pressure
- Failed coolant temperature sensor
- Skipping of timing belt teeth.
- EGR system and EGR valve failed
- Failed engine-ECU <M/T>
- Failed engine-A/T-ECU <A/T>

DIAGNOSIS PROCEDURE

STEP 1. M.U.T.-II/III data list

- Refer to data list reference table [P.13A-376](#).
 - Item 22: Crank angle sensor

OK: Keep the engine speed constant to make the pulse width of output waveform constant.

Q: Is the check result normal?

YES : Go to Step 2 .

NO : Check crank angle sensor system (Refer to Code No. P0335 [P.13A-161](#)).

STEP 2. M.U.T.-II/III data list

- Refer to data list reference table [P.13A-376](#).
 - Item 21: Engine coolant temperature sensor
 - Item 81: Long-term fuel compensation
 - Item 82: Short-term fuel compensation

Q: Are the check results normal?

YES : Go to Step 3 .

NO : Perform the diagnosis code classified check procedure for the sensor that has shown an abnormal data value (Refer to, Inspection Chart for diagnosis codes [P.13A-17](#)).

STEP 3. Check ignition secondary voltage waveform using an oscilloscope.

- Check ignition secondary voltage waveform (Refer to GROUP 16 – Ignition System –On-vehicle Service [P.16-32](#)).

Q: Is the check result normal?

YES : Go to Step 4 .

NO : Check ignition circuit system (Refer to Inspection procedure 28 <L.H. drive vehicles> [P.13A-361](#) or Inspection procedure 29 <R.H. drive vehicles> [P.13A-368](#)).

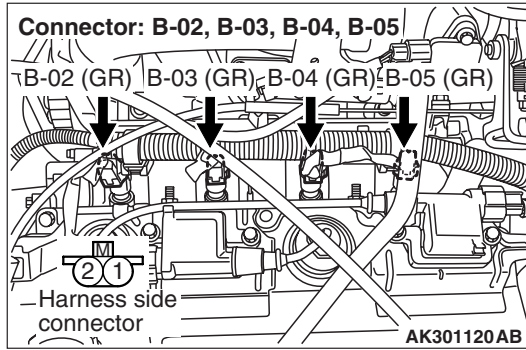
STEP 4. Connector check: Injector connector

- B-02 (No.1 injector connector)
- B-03 (No.2 injector connector)
- B-04 (No.3 injector connector)
- B-05 (No.4 injector connector)

Q: Are the check results normal?**YES** : Go to Step 5 .**NO** : Repair or replace.**STEP 5. Check injector itself.**

- Check Injector itself (Refer to [P.13A-407](#)).

Q: Is the check result normal?**YES** : Go to Step 6 .**NO** : Replace injector.

STEP 6. Connector check: B-16X engine control relay connector and C-123 engine-ECU connector <M/T> connector or C-122 engine-A/T-ECU <A/T>

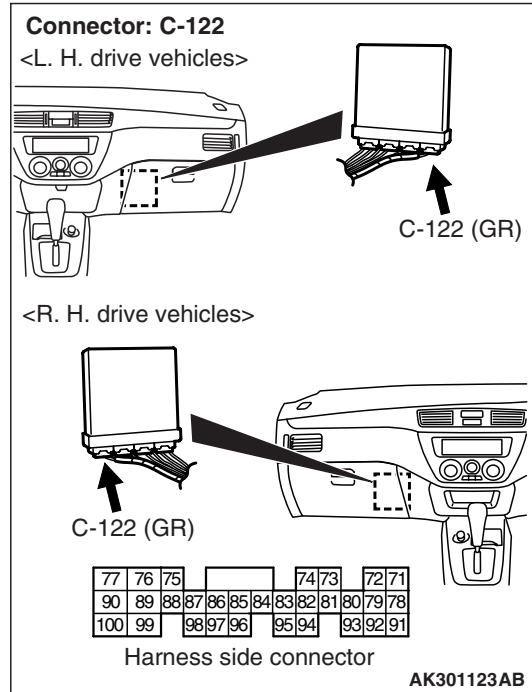
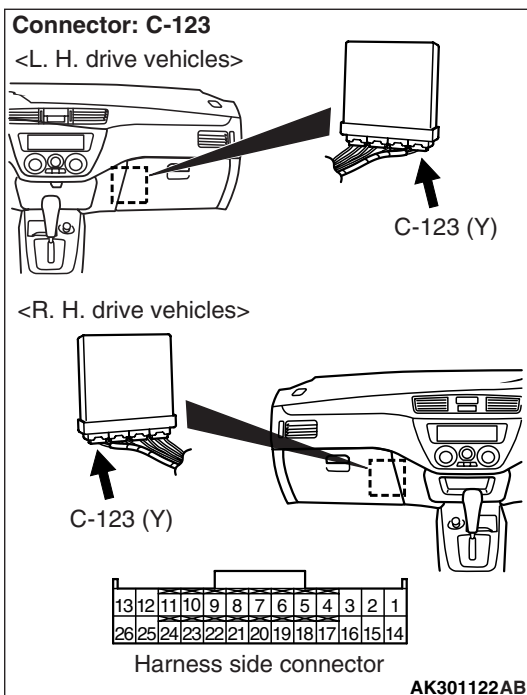
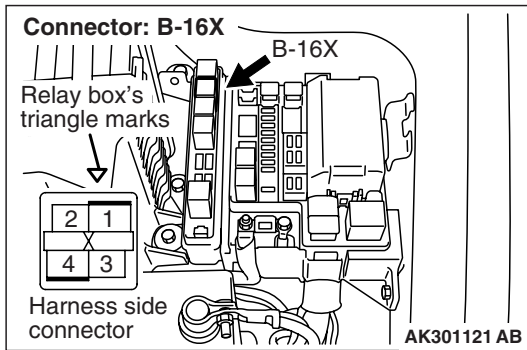

Q: Is the check result normal?
YES : Go to Step 7 .
NO : Repair or replace.

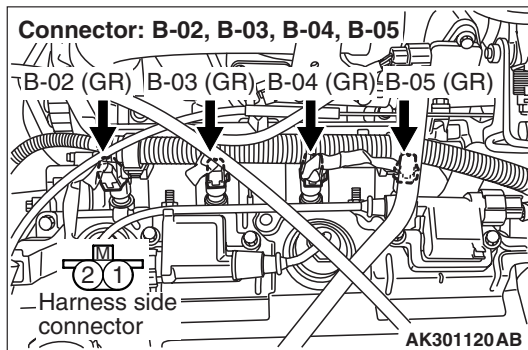
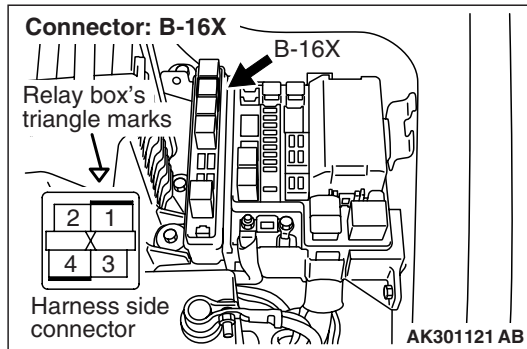
STEP 7. Check harness between B-16X engine control relay connector and injector connector.

- Check harness between B-16X (terminal No. 1) engine control relay connector and B-02 (terminal No. 1) No. 1 injector connector.
- Check harness between B-16X (terminal No. 1) engine control relay connector and B-03 (terminal No. 1) No. 2 injector connector.
- Check harness between B-16X (terminal No. 1) engine control relay connector and B-04 (terminal No. 1) No. 3 injector connector.
- Check harness between B-16X (terminal No. 1) engine control relay connector and B-05 (terminal No. 1) No. 4 injector connector.
 - Check power supply line for damage.

Q: Are the check results normal?

YES : Go to Step 8 .

NO : Repair.

STEP 8. Check harness between injector connector and C-123 engine-ECU <M/T> connector or C-122 engine-A/T-ECU <A/T> connector.

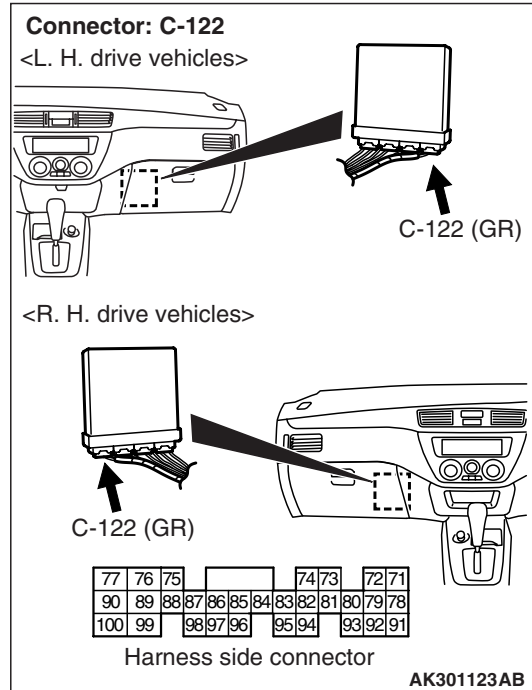
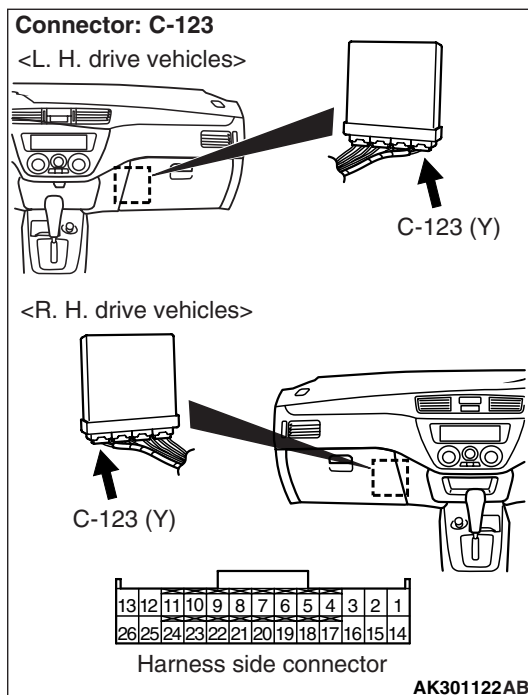
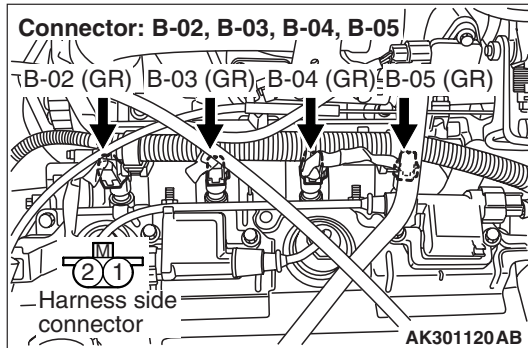

- Check harness between B-02 (terminal No. 2) No. 1 injector connector and C-123 (terminal No. 1) engine-ECU <M/T> connector or C-122 (terminal No. 1) engine-A/T-ECU <A/T> connector.
- Check harness between B-03 (terminal No. 2) No. 2 injector connector and C-123 (terminal No. 14) engine-ECU <M/T> connector or C-122 (terminal No. 9) engine-A/T-ECU <A/T> connector.
- Check harness between B-04 (terminal No. 2) No. 3 injector connector and C-123 (terminal No. 2) engine-ECU <M/T> connector or C-122 (terminal No. 24) engine-A/T-ECU <A/T> connector.
- Check harness between B-05 (terminal No. 2) No. 4 injector connector and C-123 (terminal No. 15) engine-ECU <M/T> connector or C-122 (terminal No. 2) engine-A/T-ECU <A/T> connector.
 - Check output line for damage.

Q: Are the check results normal?

YES : Go to Step 9 .

NO : Repair.

STEP 9. Fuel pressure measurement.

- Fuel pressure measurement (Refer to fuel pressure test [P.13A-399](#))

Q: Is the check result normal?

YES : Go to Step 10 .

NO : Repair.

STEP 10. Check for intake of air from intake hose and inlet manifold.**Q: Is the check result normal?****YES :** Go to Step 11 .**NO :** Repair.**STEP 11. Check for skipped timing belt teeth.****Q: Is the check result normal?****YES :** Go to Step 12 .**NO :** Repair.**STEP 12. Exhaust gas recirculation system check.**

- Exhaust gas recirculation system check [Refer to GROUP 17 – Exhaust gas recirculation (EGR) system [P.17-15](#)].

Q: Is the check result normal?**YES :** Replace engine-ECU <M/T> or engine-A/T-ECU <A/T>.**NO :** Repair.**Code No. P0301: No. 1 Cylinder Misfire Detection System****OPERATION**

- Refer to P0201 injector circuit [P.13A-115](#).

FUNCTION

- If a misfire occurs while the engine is running, the engine speed changes for an instant.
- The engine-ECU <M/T> or engine-A/T-ECU <A/T> checks for such changes in engine speed.

TROUBLE JUDGMENT**Check Conditions**

- 5 seconds later after the engine has started up.
- The engine speed is 500 – 4,500 r/min.
- The intake manifold pressure is 32 kPa or more.
- The engine coolant temperature is –10° C or higher.
- The intake air temperature is –10° C or higher.
- The barometric pressure is 72 kPa or more.
- The adaptive learning has been completed with the vane that generates the crankshaft position signals.
- During the engine operation except the shift change or low speed driving and rapid acceleration and deceleration, also intermittent operation of air compressor (A/C: within the 3 seconds after changing to ON from OFF or to OFF from ON).
- The throttle deviation is within the range of -0.059 V/10ms to 0.059 V/10ms.

Judgment Criteria

- The number of misfiring (in the catalyst temperature of above 950° C) is beyond the specified number (of 7.3% on only No. 1 cylinder) with the engine speed of 200 r/min.
- or
- The number of misfiring (that is 1.5 times the emission standard limit) is beyond the specified number (of 2% on only No. 1 cylinder) with the engine speed of 1,000 r/min.

PROBABLE CAUSE

- Ignition system related part(s) failed
- Low compression pressure
- Failed engine-ECU <M/T>
- Failed engine-A/T-ECU <A/T>

DIAGNOSIS PROCEDURE**STEP 1. Check ignition coil spark.****Q: Is the check result normal?****YES :** Go to Step 2 .**NO :** Check ignition Circuit System (Refer to Inspection procedure 28 <L.H. drive vehicles> [P.13A-361](#) or Inspection procedure 29 <R.H. drive vehicles> [P.13A-368](#)).

STEP 2. Connector check: B-02 No. 1 injector connector

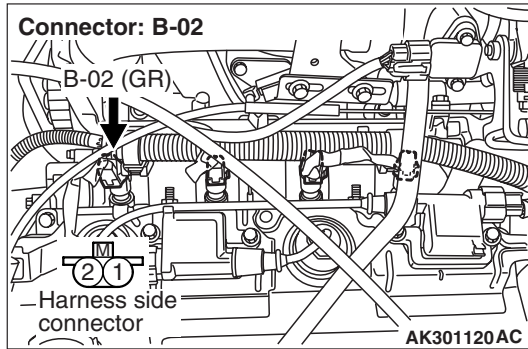

Q: Is the check result normal?
YES : Go to Step 3 .
NO : Repair or replace.

STEP 3. Check No. 1 injector itself.

- Check Injector itself (Refer to P.13A-407).

Q: Is the check result normal?
YES : Go to Step 4 .
NO : Replace No. 1 injector.

STEP 4. Connector check: B-16X engine control relay connector and C-123 engine-ECU <M/T> connector or C-122 engine-A/T-ECU <A/T> connector

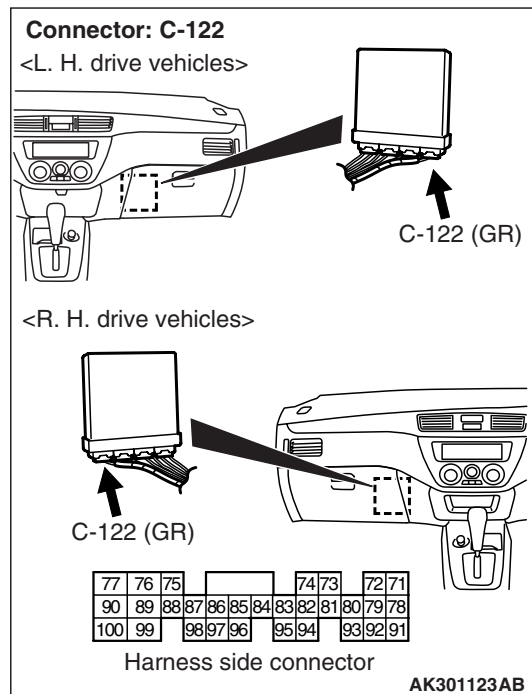
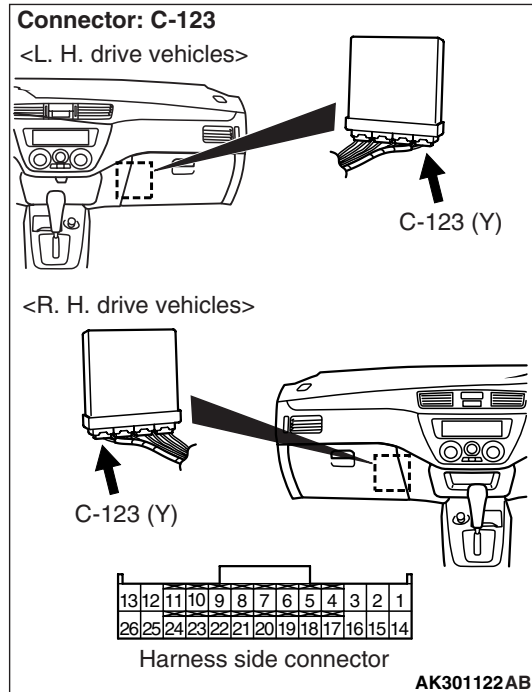
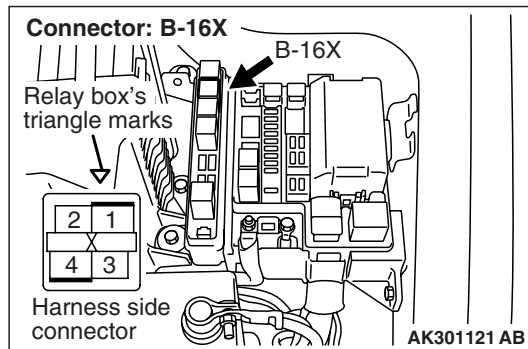

Q: Is the check result normal?
YES : Go to Step 5 .
NO : Repair or replace.

STEP 5. Check harness between B-16X (terminal No. 4) engine control relay connector and B-02 (terminal No. 1) No. 1 injector connector.

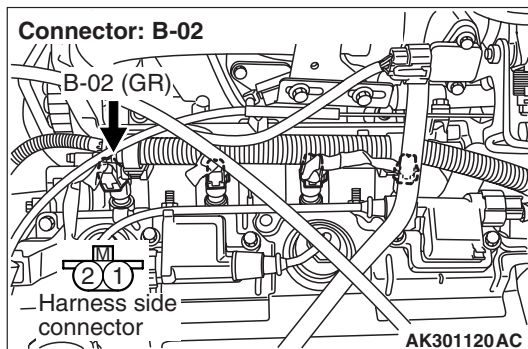
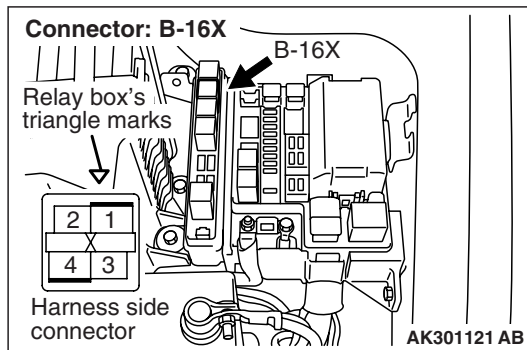

- Check power supply line for damage.

Q: Is the check result normal?

YES : Go to Step 6 .

NO : Repair.

STEP 6. Check harness between B-02 (terminal No. 2) No.1 injector connector and C-123 (terminal No. 1) engine-ECU <M/T> connector or C-122 (terminal No. 1) engine-A/T-ECU <A/T> connector

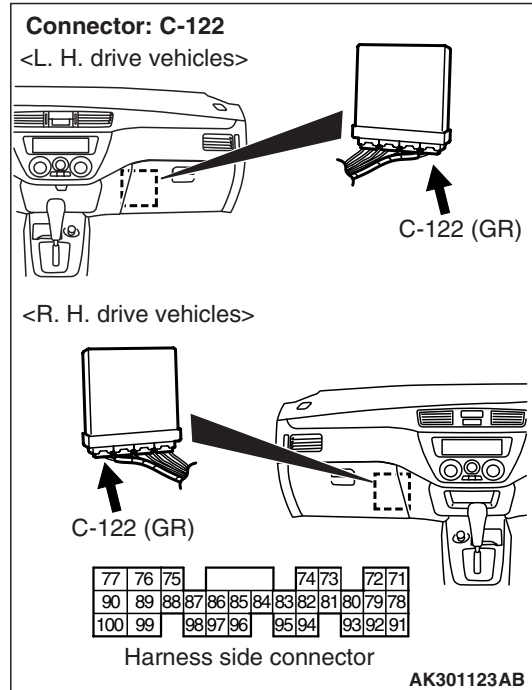
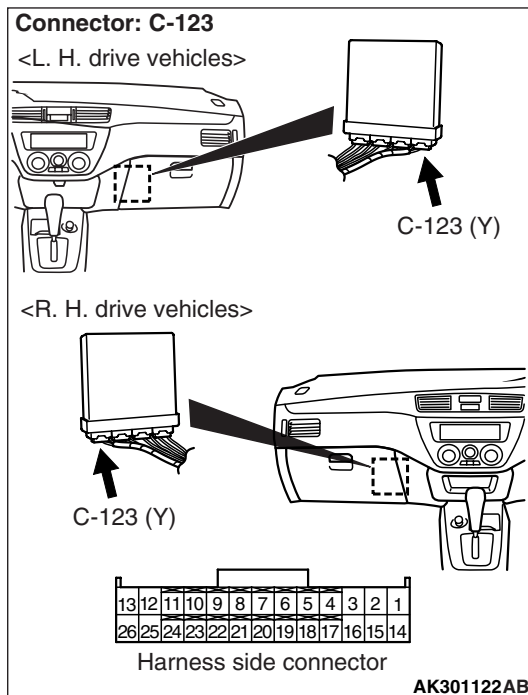
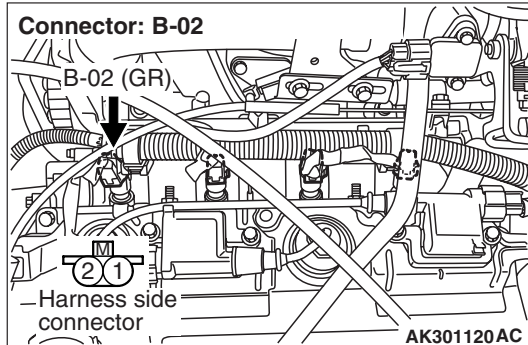

- Check output line for damage.

Q: Is the check result normal?

YES : Go to Step 7 .

NO : Repair.

STEP 7. Fuel pressure measurement.

- Fuel pressure measurement (Refer to fuel pressure test P.13A-399).

Q: Is the check result normal?

YES : Replace engine-ECU <M/T> or engine-A/T-ECU <A/T>.

NO : Repair.

Code No. P0302: No. 2 Cylinder Misfire Detection System

OPERATION

- Refer to P0202 injector circuit P.13A-121.

FUNCTION

- If a misfire occurs while the engine is running, the engine speed changes for an instant.
- The engine-ECU <M/T> or engine-A/T-ECU <A/T> checks for such changes in engine speed.

TROUBLE JUDGMENT

Check Conditions

- 5 seconds later after the engine has started up.
- The engine speed is 500 – 4,500 r/min.
- The intake manifold pressure is 32 kPa or more.
- The engine coolant temperature is –10° C or higher.
- The intake air temperature is –10° C or higher.
- The barometric pressure is 72 kPa or more.
- The adaptive learning has been completed with the vane that generates the crankshaft position signals.

- During the engine operation except the shift change or low speed driving and rapid acceleration and deceleration, also intermittent operation of air compressor (A/C: within the 3 seconds after changing to ON from OFF or to OFF from ON).
- The throttle deviation is within the range of – 0.059 V/10ms to 0.059 V/10ms.

Judgment Criteria

- The number of misfiring (in the catalyst temperature of above 950°C) is beyond the specified number (of 7.3% on only No. 2 cylinder) with the engine speed of 200 r/min.

or

- The number of misfiring (that is 1.5 times the emission standard limit) is beyond the specified number (of 2% on only No. 2 cylinder) with the engine speed of 1,000 r/min.

PROBABLE CAUSE

- Ignition system related part(s) failed
- Low compression pressure
- Failed engine-ECU <M/T>
- Failed engine-A/T-ECU <A/T>

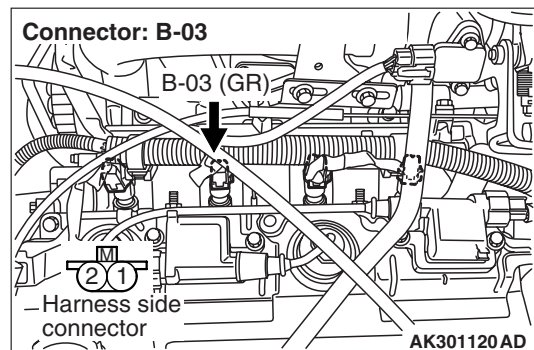
DIAGNOSIS PROCEDURE**STEP 1. Check ignition coil spark.****Q: Is the check result normal?****YES :** Go to Step 2 .**NO :** Check ignition circuit system (Refer to Inspection procedure 28 <L.H. drive vehicles> [P.13A-361](#) or Inspection procedure 29 <R.H. drive vehicles> [P.13A-368](#)).**STEP 2. Check connector: B-03 No. 2 injector connector****Q: Is the check result normal?****YES :** Go to Step 3 .**NO :** Repair or replace.**STEP 3. Check No. 2 injector itself.**

- Check Injector itself (Refer to [P.13A-407](#)).

Q: Is the check result normal?**YES :** Go to Step 4 .**NO :** Replace No. 2 injector.

STEP 4. Connector check: B-16X engine control relay connector and C-123 engine-ECU <M/T> connector or C-122 engine-A/T-ECU <A/T> connector

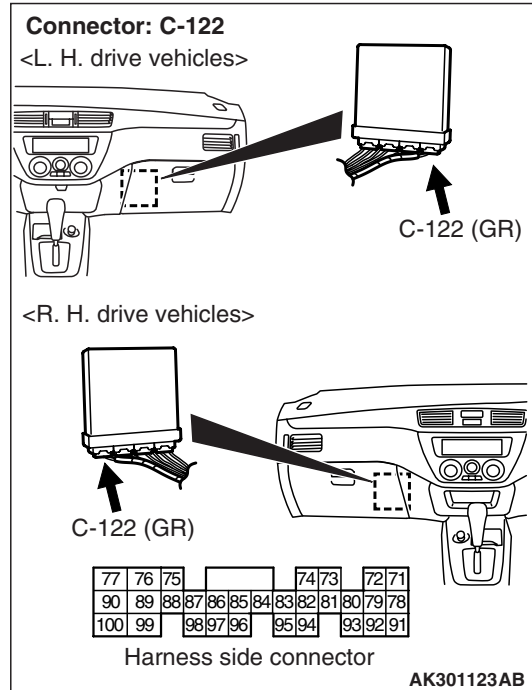
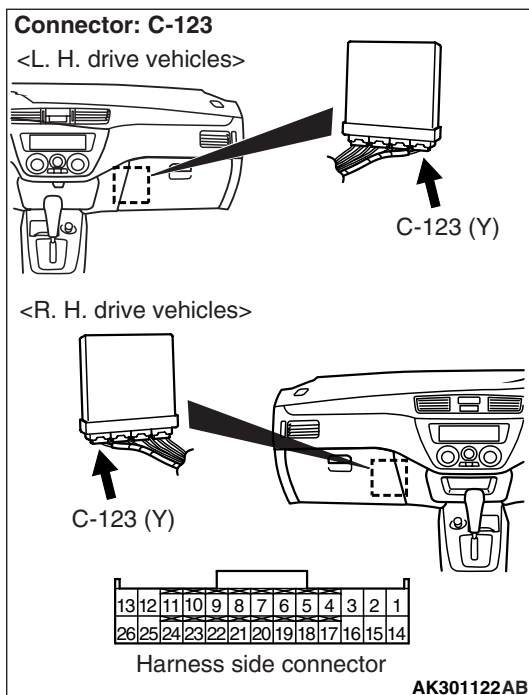
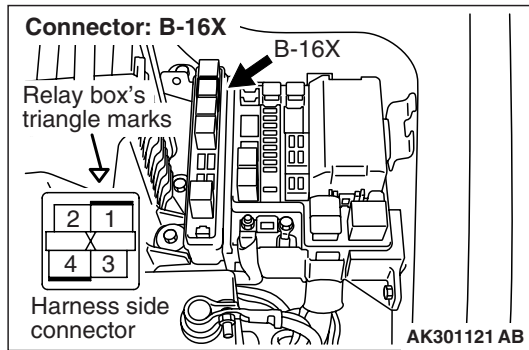

Q: Is the check result normal?
YES : Go to Step 5 .
NO : Repair or replace.

STEP 5. Check harness between B-16X (terminal No. 4) engine control relay connector and B-03 (terminal No. 1) No. 2 injector connector.

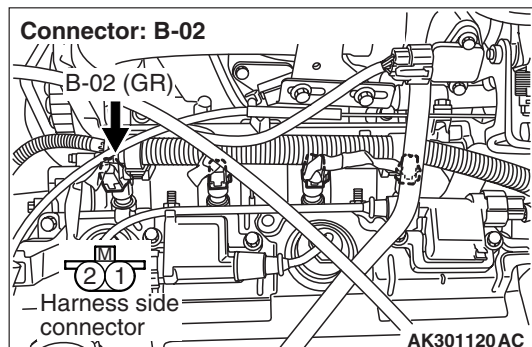
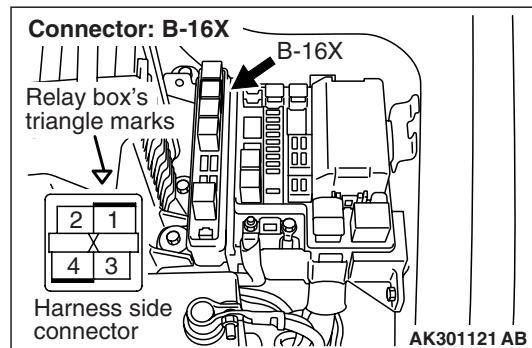

- Check power supply line for damage.

Q: Is the check result normal?
YES : Go to Step 6 .
NO : Repair.

STEP 6. Check harness between B-03 (terminal No. 2) No. 2 injector connector and C-123 (terminal No. 14) engine-ECU <M/T> connector or C-122 (terminal No. 9) engine-A/T-ECU <A/T> connector

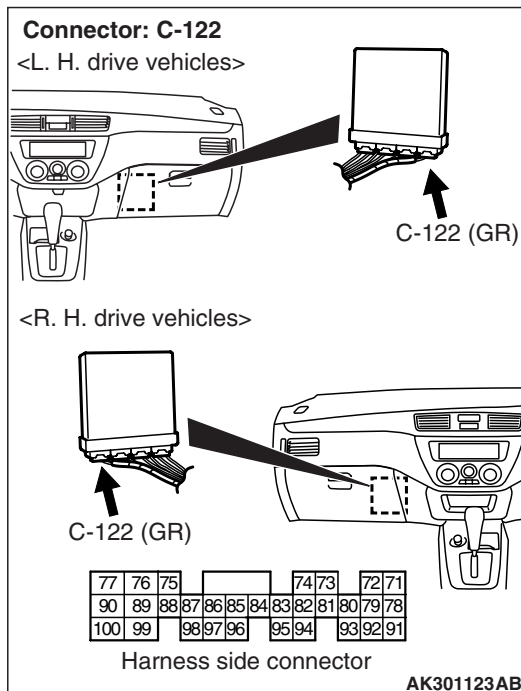
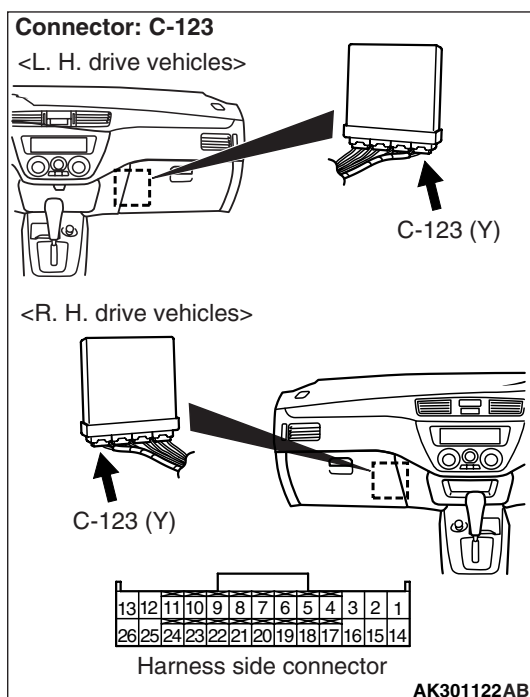
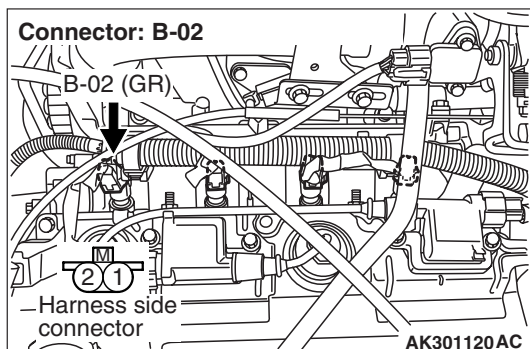

- Check output line for damage.

Q: Is the check result normal?

- YES :** Go to Step 7 .
NO : Repair.

STEP 7. Fuel pressure measurement.

- Fuel pressure measurement (Refer to fuel pressure test P.13A-399)

Q: Is the check result normal?

- YES :** Replace engine-ECU <M/T> or engine-A/T-ECU <A/T>.
NO : Repair.

Code No. P0303: No. 3 Cylinder Misfire Detection System

OPERATION

- Refer to P0203 injector circuit P.13A-127.

FUNCTION

- If a misfire occurs while the engine is running, the engine speed changes for an instant.
- The engine-ECU <M/T> or engine-A/T-ECU <A/T> checks for such changes in engine speed.

TROUBLE JUDGMENT

Check Conditions

- 5 seconds later after the engine has started up.
- The engine speed is 500 – 4,500 r/min.
- The intake manifold pressure is 32 kPa or more.
- The engine coolant temperature is – 10° C or higher.
- The intake air temperature is – 10° C or higher.
- The barometric pressure is 72 kPa or more.
- The adaptive learning has been completed with the vane that generates the crankshaft position signals.

- During the engine operation except the shift change or low speed driving and rapid acceleration and deceleration, also intermittent operation of air compressor (A/C: within the 3 seconds after changing to ON from OFF or to OFF from ON).
- The throttle deviation is within the range of – 0.059 V/10ms to 0.059 V/10ms.

Judgment Criteria

- The number of misfiring (in the catalyst temperature of above 950°C) is beyond the specified number (of 7.3% on only No. 3 cylinder) with the engine speed of 200 r/min.

or

- The number of misfiring (that is 1.5 times the emission standard limit) is beyond the specified number (of 2% on only No. 3 cylinder) with the engine speed of 1,000 r/min.

PROBABLE CAUSE

- Ignition system related part(s) failed
- Low compression pressure
- Failed engine-ECU <M/T>
- Failed engine-A/T-ECU <A/T>

DIAGNOSIS PROCEDURE

STEP 1. Check ignition coil spark.

Q: Is the check result normal?

YES : Go to Step 2 .

NO : Check ignition circuit system (Refer to Inspection procedure 28 <L.H. drive vehicles> [P.13A-361](#) or Inspection procedure 29 <R.H. drive vehicles> [P.13A-368](#)).

STEP 2. Connector check: B-04 No. 3 injector connector

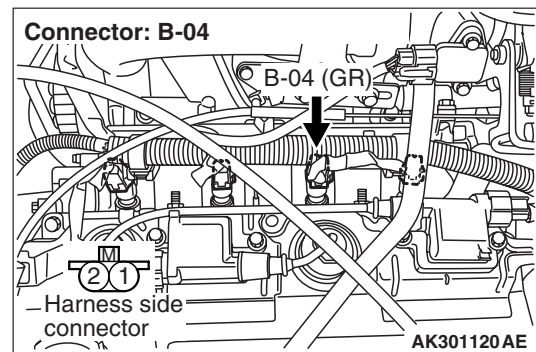

Q: Is the check result normal?

YES : Go to Step 3 .

NO : Repair or replace.

STEP 3. Check No. 3 injector itself.

- Check Injector itself (Refer to [P.13A-407](#)).

Q: Is the check result normal?

YES : Go to Step 4 .

NO : Replace No. 3 injector.

STEP 4. Connector check: B-16X engine control relay connector, C-123 engine-ECU connector <M/T> connector or C-122 engine-A/T-ECU <A/T>

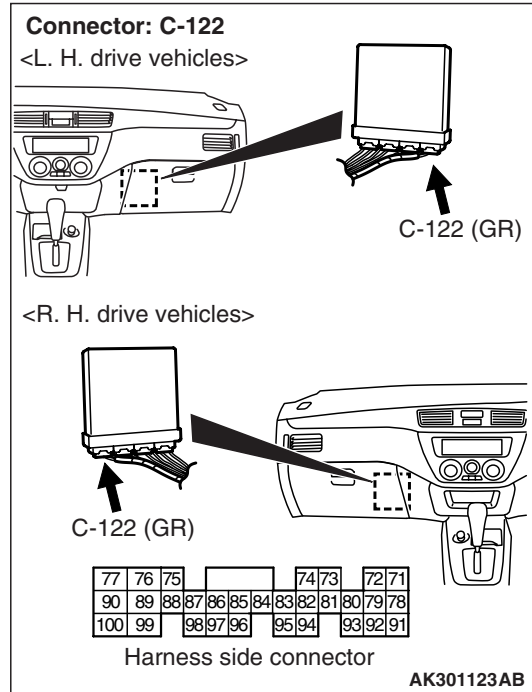
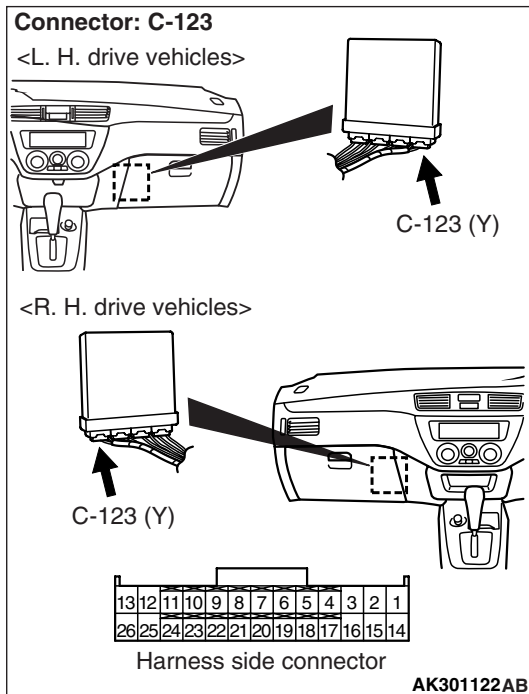
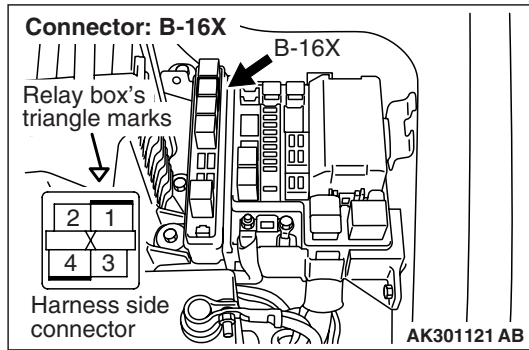

Q: Is the check result normal?
YES : Go to Step 5 .
NO : Repair or replace.

STEP 5. Check harness between B-16X (terminal No. 4) engine control relay connector and B-04 (terminal No. 1) No. 3 injector connector.

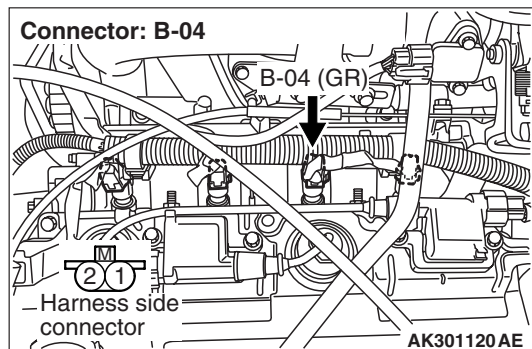
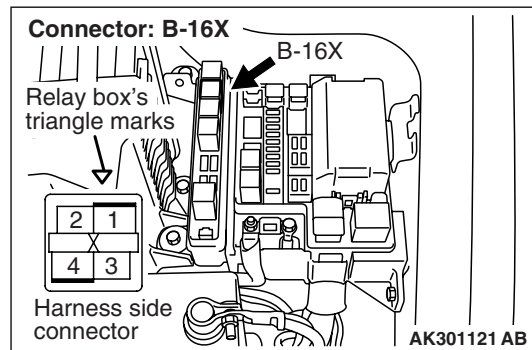

- Check power supply line for damage.

Q: Is the check result normal?
YES : Go to Step 6 .
NO : Repair.

STEP 6. Check harness between B-04 (terminal No. 2) No.3 injector connector and C-123 (terminal No. 2) engine-ECU <M/T> connector or C-122 (terminal No. 24) engine-A/T-ECU <A/T> connector

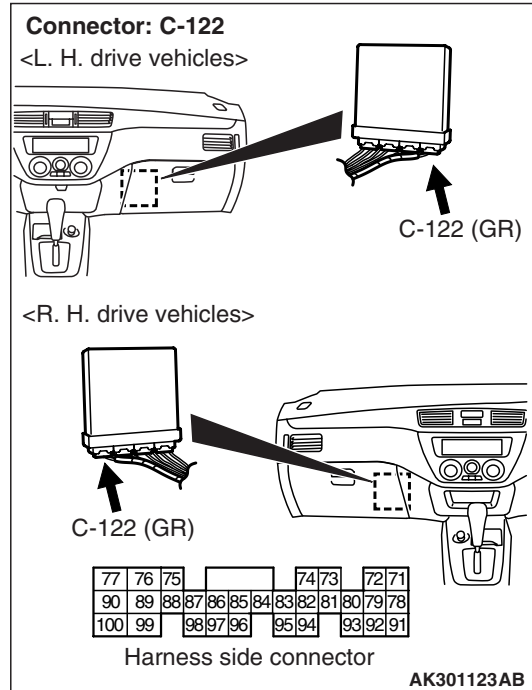
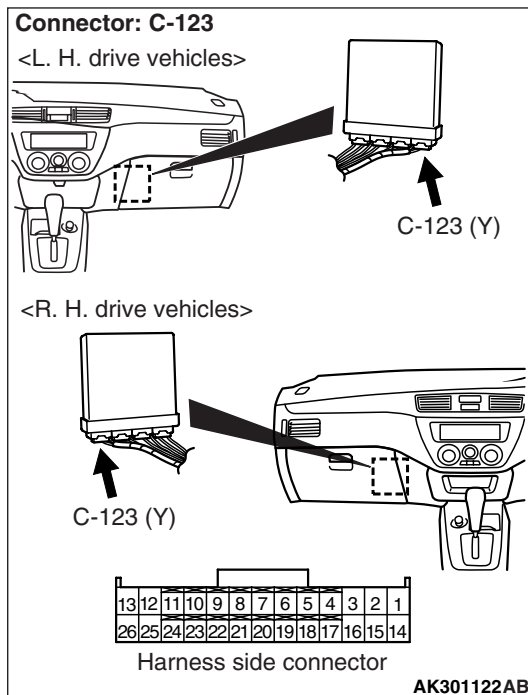
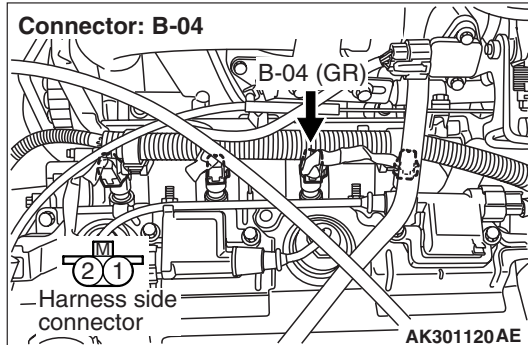

- Check output line for damage.

Q: Is the check result normal?

YES : Go to Step 7 .

NO : Repair.

STEP 7. Fuel pressure measurement.

- Fuel pressure measurement (Refer to fuel pressure test P.13A-399)

Q: Is the check result normal?

YES : Replace engine-ECU <M/T> or engine-A/T-ECU <A/T>.

NO : Repair.

Code No. P0304: No. 4 Cylinder Misfire Detection System

OPERATION

- Refer to P0204 injector circuit P.13A-133.

FUNCTION

- If a misfire occurs while the engine is running, the engine speed changes for an instant.
- The engine-ECU <M/T> or engine-A/T-ECU <A/T> checks for such changes in engine speed.

TROUBLE JUDGMENT

Check Conditions

- 5 seconds later after the engine has started up.
- The engine speed is 500 – 4,500 r/min.
- The intake manifold pressure is 32 kPa or more.
- The engine coolant temperature is –10° C or higher.
- The intake air temperature is –10° C or higher.
- The barometric pressure is 72 kPa or more.
- The adaptive learning has been completed with the vane that generates the crankshaft position signals.

- During the engine operation except the shift change or low speed driving and rapid acceleration and deceleration, also intermittent operation of air compressor (A/C: within the 3 seconds after changing to ON from OFF or to OFF from ON).
- The throttle deviation is within the range of – 0.059 V/10ms to 0.059 V/10ms.

Judgment Criteria

- The number of misfiring (in the catalyst temperature of above 950°C) is beyond the specified number (of 7.3% on only No. 4 cylinder) with the engine speed of 200 r/min.

or

- The number of misfiring (that is 1.5 times the emission standard limit) is beyond the specified number (of 2% on only No. 4 cylinder) with the engine speed of 1,000 r/min.

PROBABLE CAUSE

- Ignition system related part(s) failed
- Low compression pressure
- Failed engine-ECU <M/T>
- Failed engine-A/T-ECU <A/T>

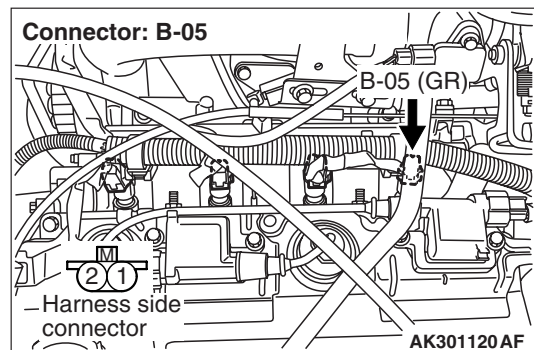
DIAGNOSIS PROCEDURE**STEP 1. Check the ignition coil spark.****Q: Is the check result normal?****YES** : Go to Step 2 .**NO** : Check ignition Circuit System (Refer to Inspection procedure 28 <L.H. drive vehicles> [P.13A-361](#) or Inspection procedure 29 <R.H. drive vehicles> [P.13A-368](#)).**STEP 2. Connector check: B-05 No.4 injector connector****Q: Is the check result normal?****YES** : Go to Step 3 .**NO** : Repair or replace.**STEP 3. Check No. 4 injector itself.**

- Check Injector itself (Refer to [P.13A-407](#)).

Q: Is the check result normal?**YES** : Go to Step 4 .**NO** : Replace No. 4 injector.

STEP 4. Connector check: B-16X engine control relay connector and C-123 engine-ECU connector <M/T> connector or C-122 engine-A/T-ECU <A/T>

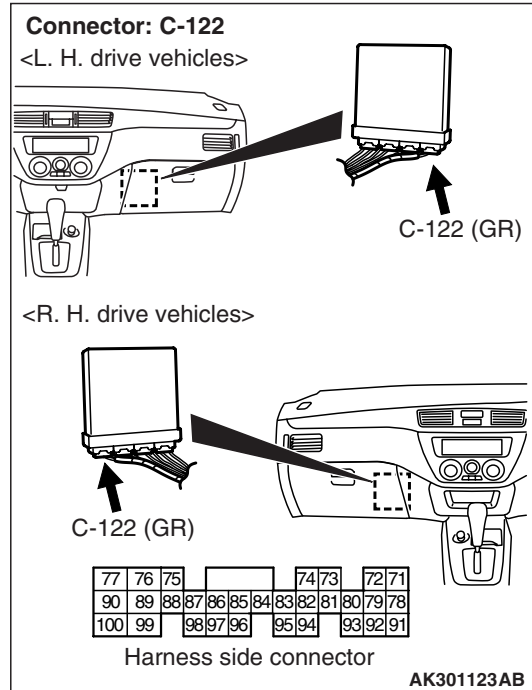
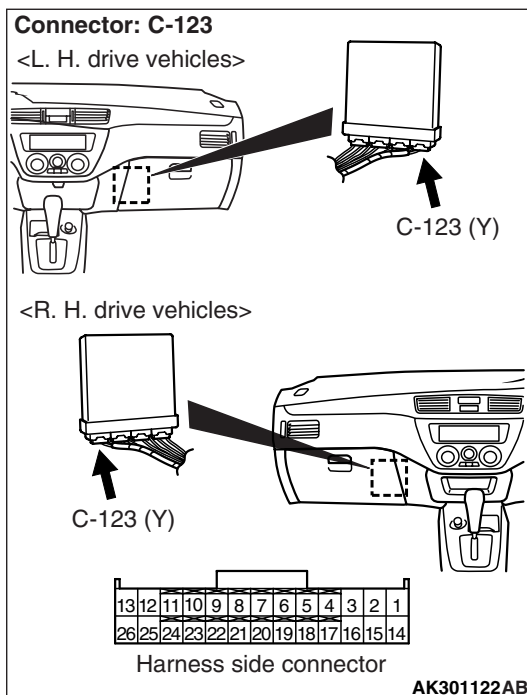
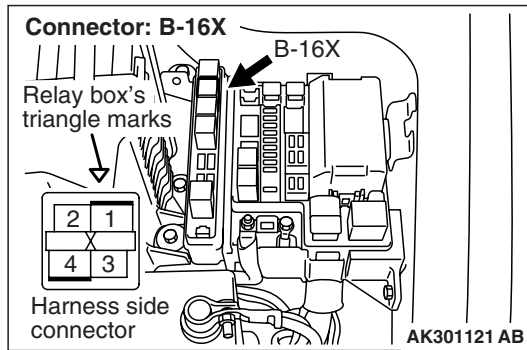

Q: Is the check result normal?
YES : Go to Step 5 .
NO : Repair or replace.

STEP 5. Check harness between B-16X (terminal No. 4) engine control relay connector and B-05 (terminal No. 1) No. 4 injector connector.

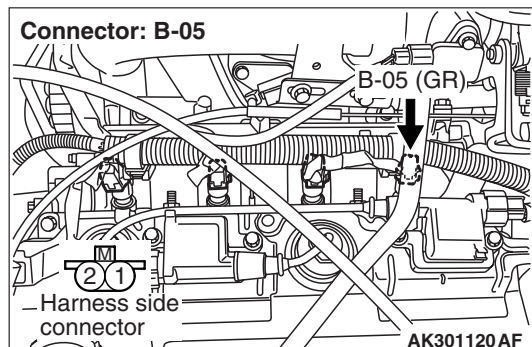
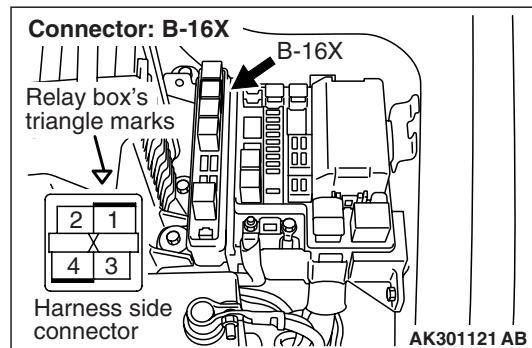

- Check power supply line for damage.

Q: Is the check result normal?
YES : Go to Step 6 .
NO : Repair.

STEP 6. Check harness between B-05 (terminal No. 2) No.4 injector connector and C-123 (terminal No. 15) engine-ECU <M/T> connector or C-122 (terminal No. 2) engine-A/T-ECU <A/T> connector.

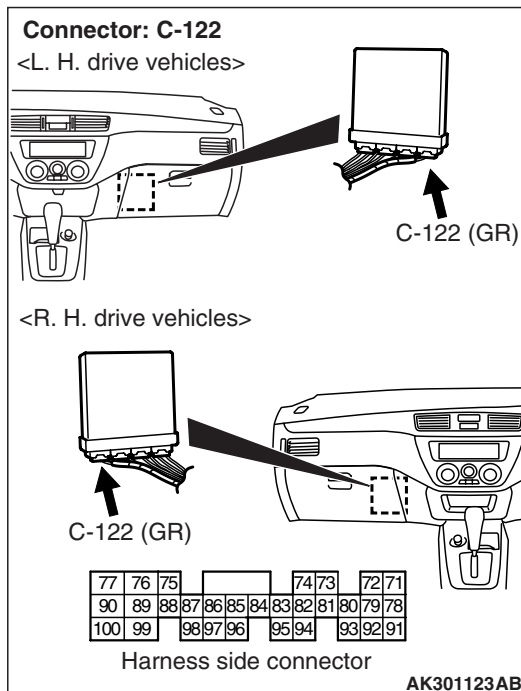
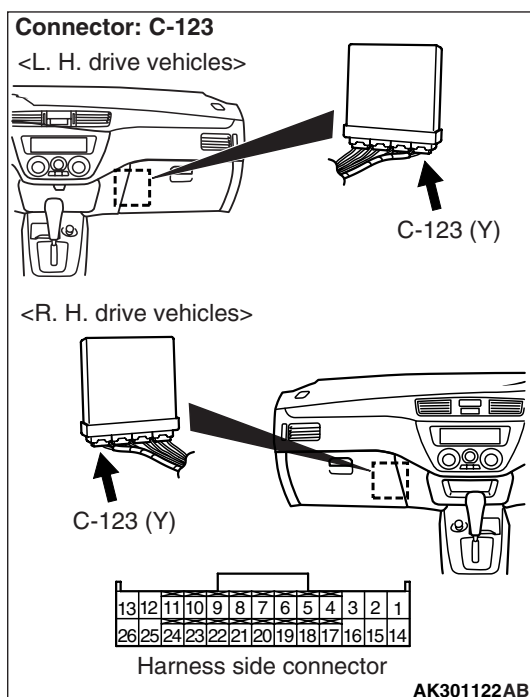
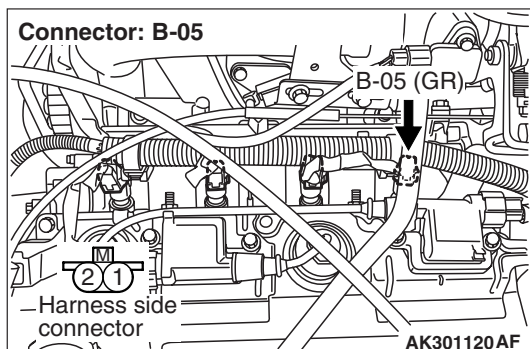

- Check output line for damage.

Q: Is the check result normal?

YES : Go to Step 7 .

NO : Repair.

STEP 7. Fuel pressure measurement.

- Fuel pressure measurement (Refer to fuel pressure test P.13A-399)

Q: Is the check result normal?

YES : Replace engine-ECU <M/T> or engine-A/T-ECU <A/T>.

NO : Repair.

Code No. P0325: Detonation Sensor System

Detonation sensor circuit

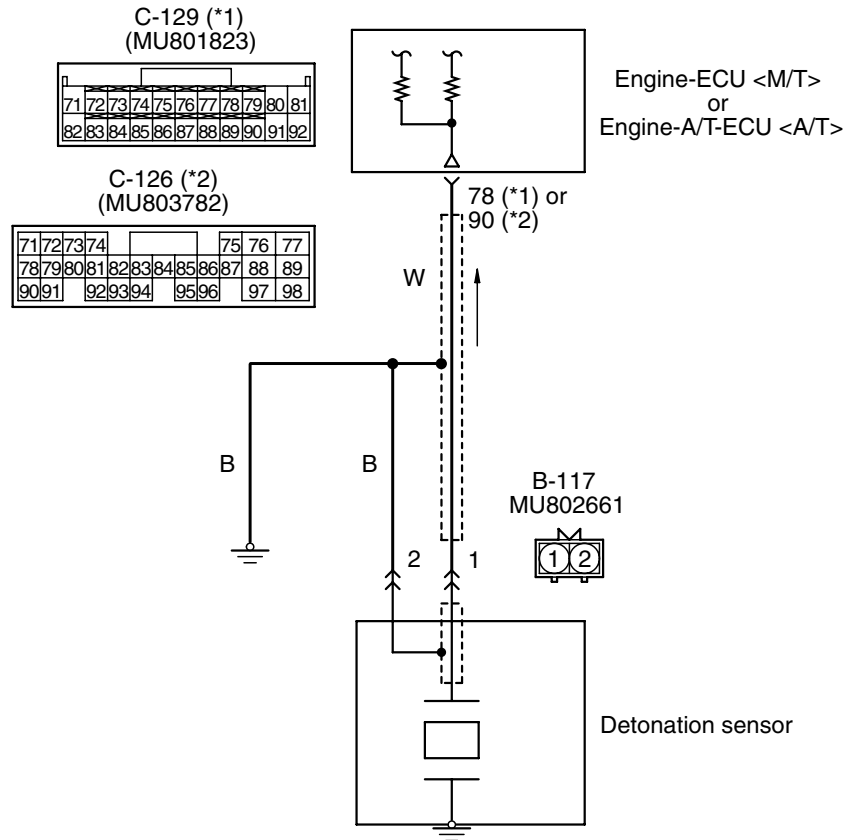

NOTE

*1: M/T

*2: A/T

Wire colour code

B: Black LG: Light green G: Green L: Blue W: White Y: Yellow SB: Sky blue BR: Brown O: Orange GR: Gray
R: Red P: Pink V: Violet

AK401353AB

OPERATION

- The sensor signal is inputted to the engine-ECU (terminal No. 78) <M/T> or engine-A/T-ECU (terminal No. 90) <A/T> from the detonation sensor (terminal No. 1).

FUNCTION

- The detonation sensor detects the vibration of the cylinder block caused by detonation waves, and inputs a signal to the engine-ECU <M/T> or engine-A/T-ECU <A/T>.
- In response to the signal, the engine-ECU <M/T> or engine-A/T-ECU <A/T> provides controls to retard the ignition timing when the detonation occurs.

TROUBLE JUDGMENT**Check Condition**

- 2 seconds later after the engine has started up.

Judgment Criterion

- The change amount of the detonation sensor output voltage (the detonation sensor peak voltage in every one half a turn of the crankshaft) is below 0.08 V in 200 consecutive times.

PROBABLE CAUSE

- Failed detonation sensor
- Open/short circuit in detonation sensor circuit or loose connector contact
- Failed engine-ECU <M/T>
- Failed engine-A/T-ECU <A/T>

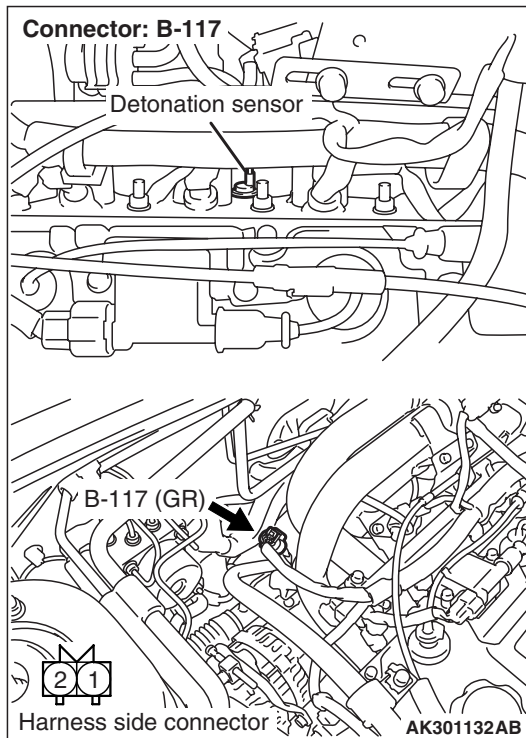
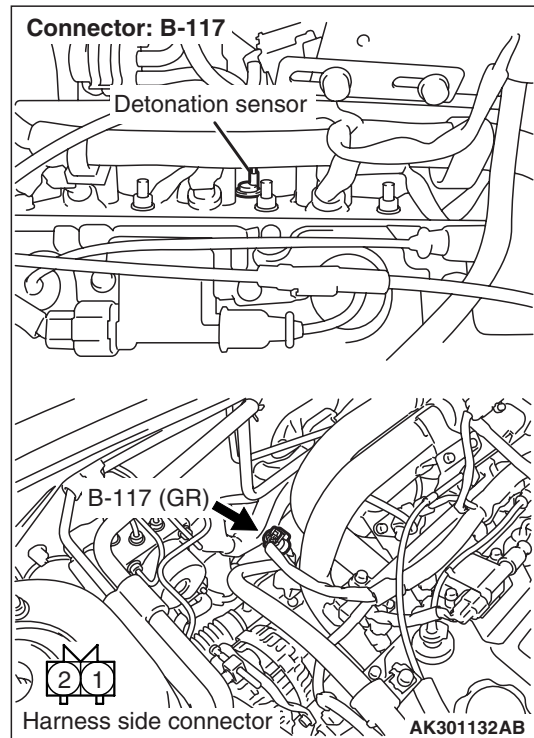
DIAGNOSIS PROCEDURE**STEP 1. Connector check: B-117 detonation sensor connector****Q: Is the check result normal?****YES** : Go to Step 2 .**NO** : Repair or replace.**STEP 2. Perform resistance measurement at B-117 detonation sensor connector.**

- Disconnect connector, and measure at harness side.
- Resistance between terminal No. 2 and earth.
OK: Continuity (2 Ω or less)

Q: Is the check result normal?**YES** : Go to Step 3 .**NO** : Check and repair harness between B-117 (terminal No. 2) detonation sensor connector and body earth.

- Check earthing line for open circuit and damage.

**STEP 3. Connector check: C-129 engine-ECU
<M/T> connector or C-126 engine-A/T-ECU <A/T>
connector**

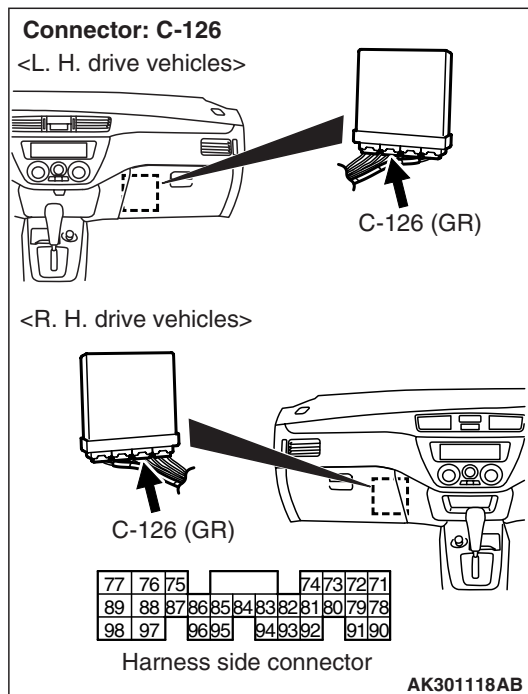
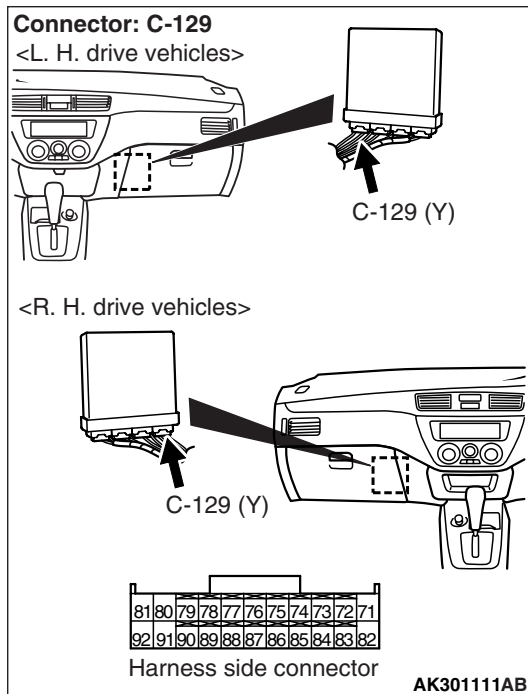

Q: Is the check result normal?

YES : Go to Step 4 .

NO : Repair or replace.

STEP 4. Check harness between B-117 (terminal No. 1) detonation sensor connector and C-129 (terminal No.78) engine-ECU <M/T> connector or C-126 (terminal No. 90) engine-A/T-ECU <A/T> connector.

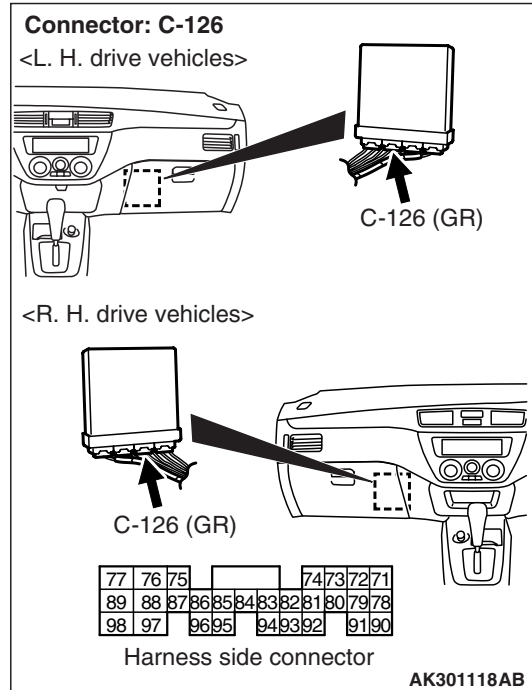
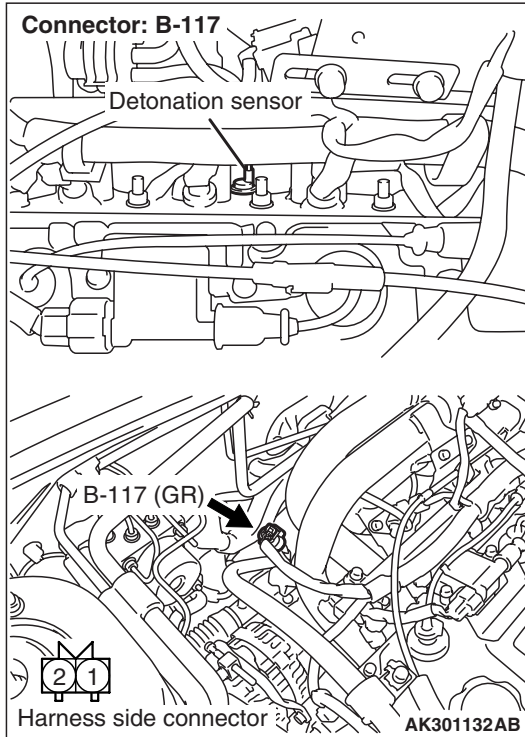

- Check output line for open/short circuit and damage.

Q: Is the check result normal?

YES : Go to Step 5 .

NO : Repair.

STEP 5. Check the trouble symptoms.

Q: Does trouble symptom persist?

YES : Go to Step 6 .

NO : Intermittent malfunction (Refer to GROUP 00 –How to Use Troubleshooting/Inspection Service Points P.00-5).

STEP 6. Replace detonation sensor.

- After replacing the detonation sensor, re-check the trouble symptoms.

Q: Does trouble symptom persist?

YES : Replace engine-ECU <M/T> or engine-A/T-ECU <A/T>.

NO : Check end.

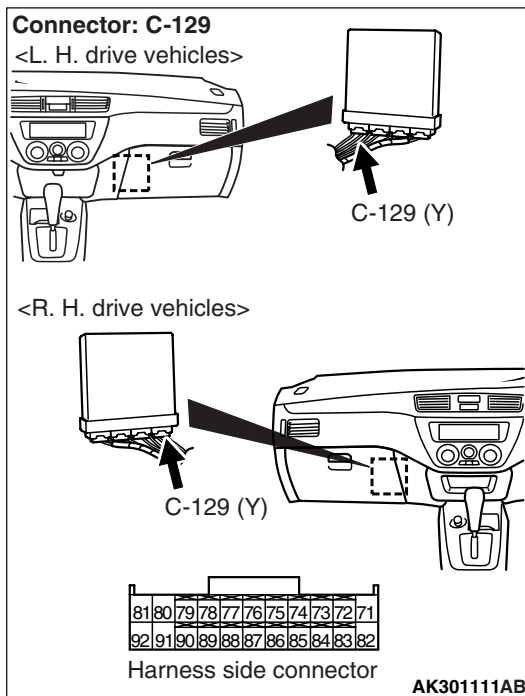

Code No. P0335: Crank Angle Sensor System

Crank angle sensor circuit

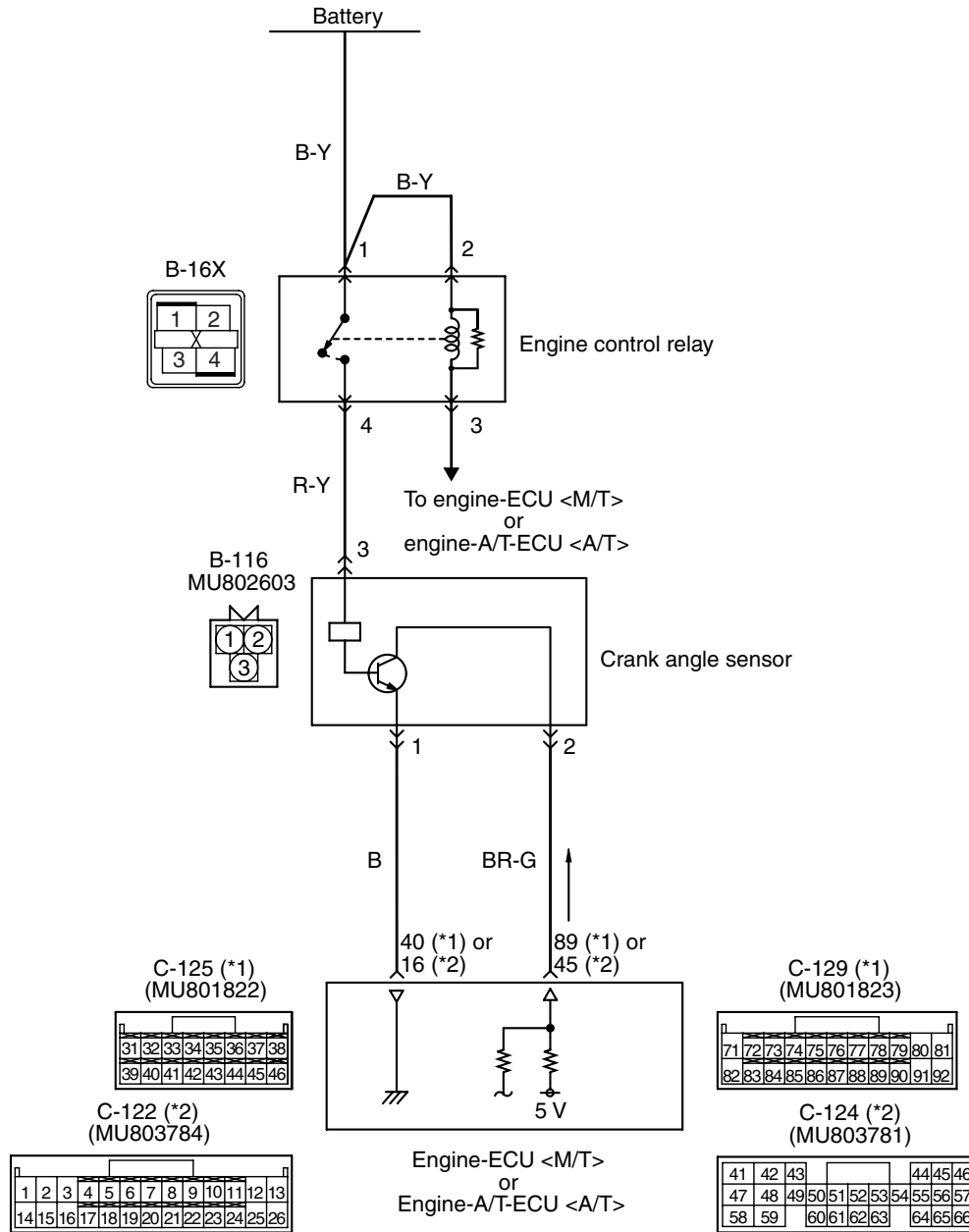

NOTE
*1: M/T
*2: A/T

Wire colour code
B: Black LG: Light green G: Green L: Blue W: White Y: Yellow SB: Sky blue BR: Brown O: Orange GR: Gray
R: Red P: Pink V: Violet

OPERATION

- Power is supplied to the crank angle sensor (terminal No. 3) from the engine control relay (terminal No. 4) and is earthed to the engine-ECU (terminal No. 40) <M/T> or engine-A/T-ECU (terminal No. 16) <A/T> from the crank angle sensor (terminal No. 1).
- A power voltage of 5 V is applied to the crank angle sensor output terminal (terminal No. 2) from the engine-ECU (terminal No. 89) <M/T> or engine-A/T-ECU (terminal No. 45) <A/T>.

FUNCTION

- The crank angle sensor detects the crank angle (position) and inputs a pulse signal to the engine-ECU<M/T> or engine-A/T-ECU<A/T>.
- In response to the signal, the engine-ECU<M/T> or engine-A/T-ECU<A/T> controls the injector, etc.

TROUBLE JUDGMENT**Check Condition**

- Engine in cranking state.

Judgment Criterion

- The sensor output voltage remains unchanged (no pulse signal is inputted) for 2 seconds.

PROBABLE CAUSE

- Failed crank angle sensor
- Open/short circuit in crank angle sensor circuit or loose connector contact
- Failed engine-ECU<M/T>
- Failed engine-A/T-ECU<A/T>

DIAGNOSIS PROCEDURE**STEP 1. M.U.T.-II/III data list**

- Refer to data list reference table [P.13A-376](#).
 - Item 22: Crank angle sensor

Q: Is the check result normal?

YES : Intermittent malfunction (Refer to GROUP 00 –How to Use Troubleshooting/Inspection Service Points [P.00-5](#)).

NO : Go to Step 2 .

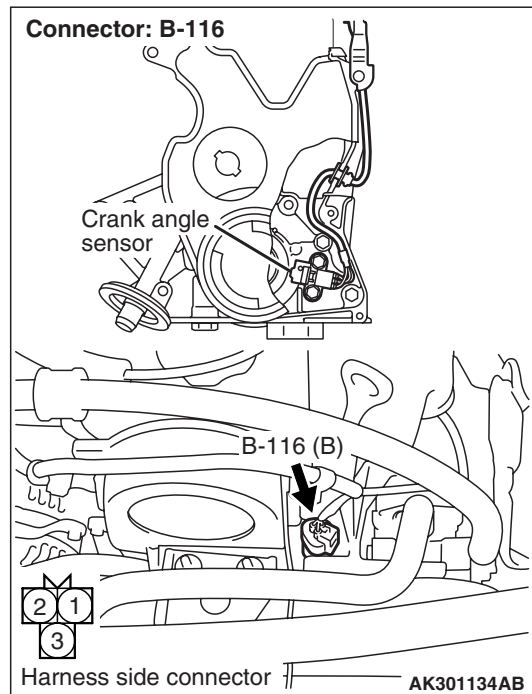
STEP 2. Connector check: B-116 crank angle sensor connector**Q: Is the check result normal?**

YES : Go to Step 3 .

NO : Repair or replace.

**STEP 3. Perform voltage measurement at B-116
crank angle sensor connector.**

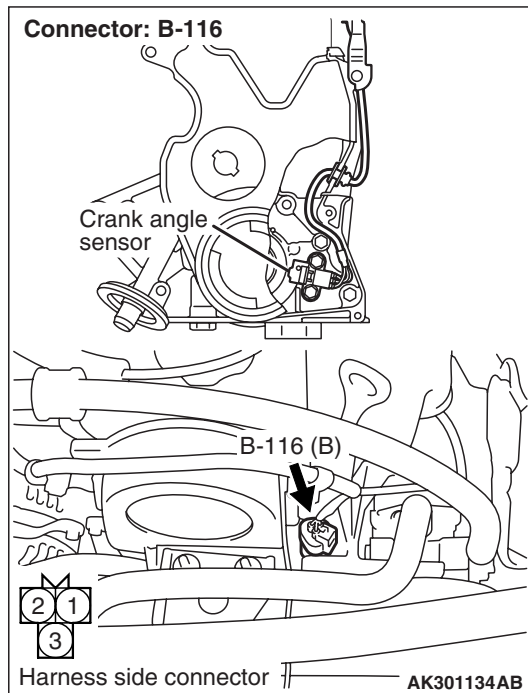

- Disconnect connector, and measure at harness side.
- Ignition switch: ON
- Voltage between terminal No. 2 and earth.

OK: 4.9 – 5.1 V

Q: Is the check result normal?

YES : Go to Step 9 .

NO : Go to Step 4 .

STEP 4. Perform voltage measurement at C-129 engine-ECU <M/T> connector or C-124 engine-A/T-ECU <A/T> connector.

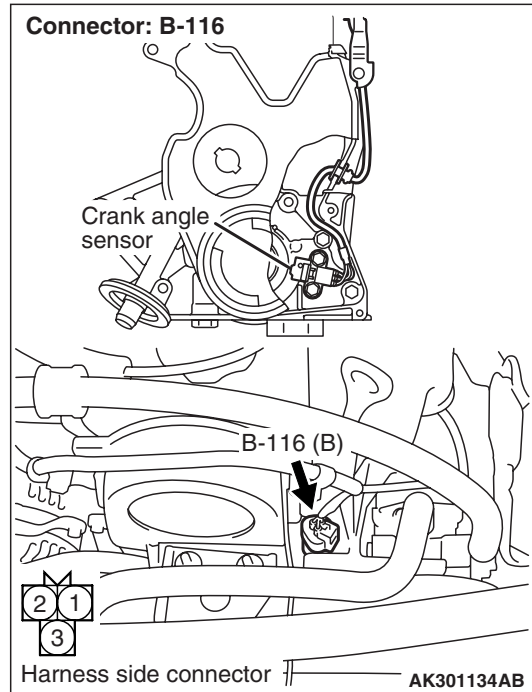
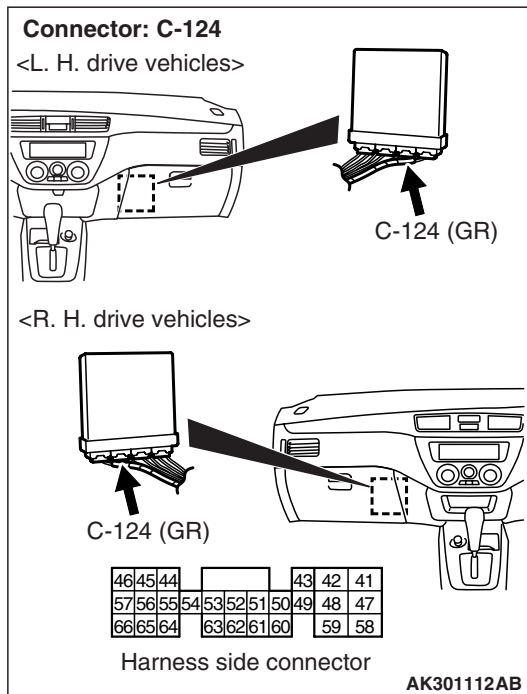
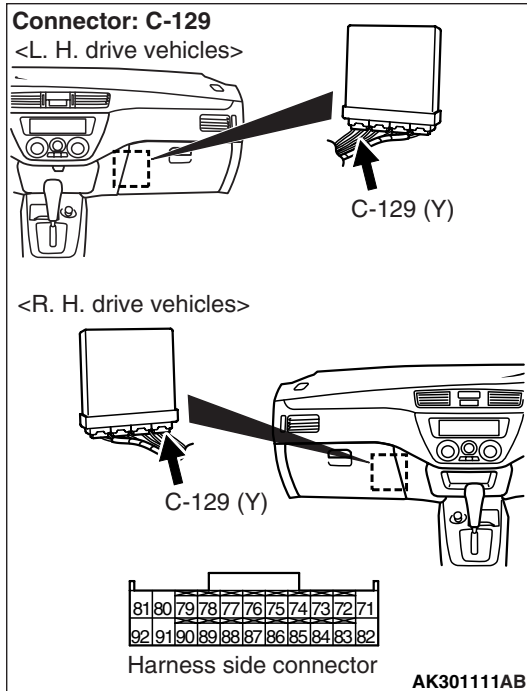

- Measure engine-ECU <M/T> or engine-A/T-ECU <A/T> terminal voltage.
- Disconnect B-116 crank angle sensor connector.
- Ignition switch: ON
- Voltage between terminal No. 89 <M/T> or terminal No. 45 <A/T> and earth.

OK: 4.9 – 5.1 V

Q: Is the check result normal?

YES : Go to Step 5 .

NO : Go to Step 6 .

STEP 5. Connector check: C-129 engine-ECU <M/T> connector or C-124 engine-A/T-ECU <A/T> connector

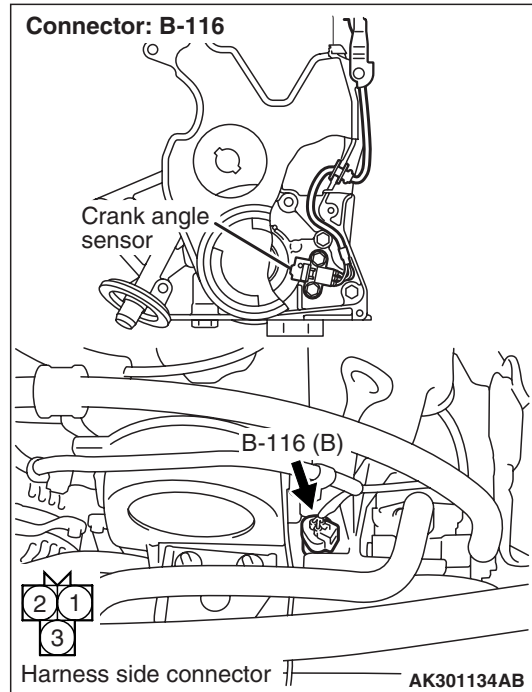
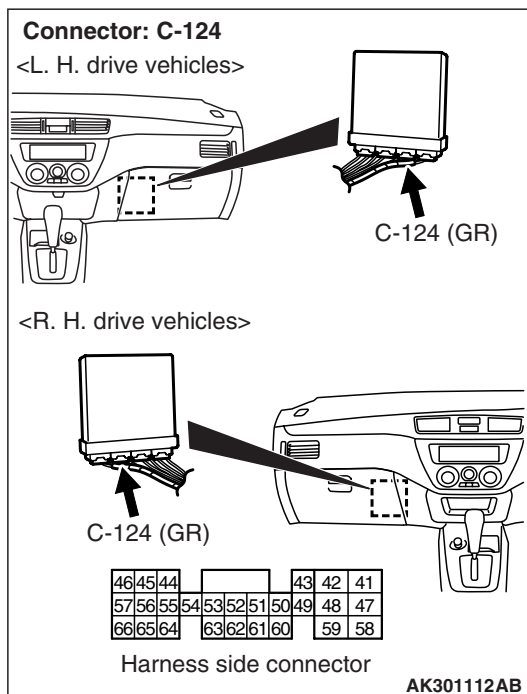
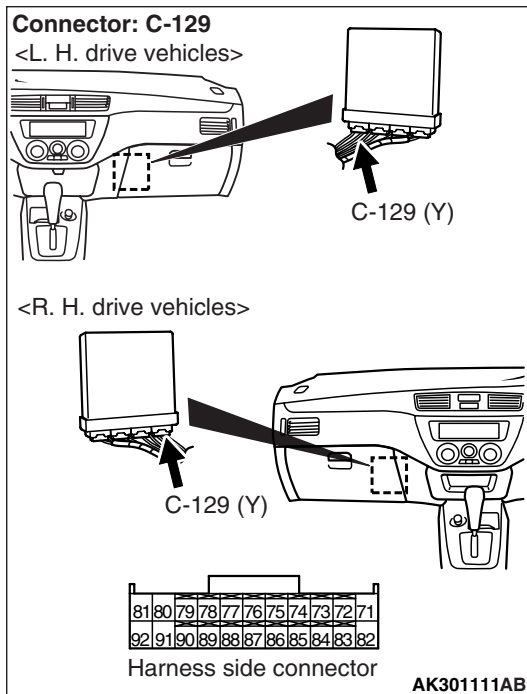

Q: Is the check result normal?

YES : Check and repair harness between B-116 (terminal No. 2) crank angle sensor connector and C-129 (terminal No. 89) engine-ECU <M/T> connector or C-124 (terminal No. 45) engine-A/T-ECU <A/T> connector.

- Check output line for open circuit.

NO : Repair or replace.

STEP 6. Connector check: C-129 engine-ECU <M/T> connector or C-124 engine-A/T-ECU <A/T> connector

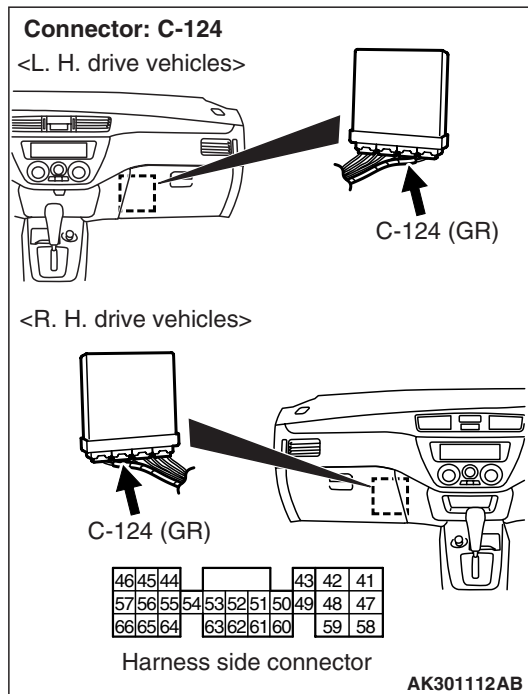
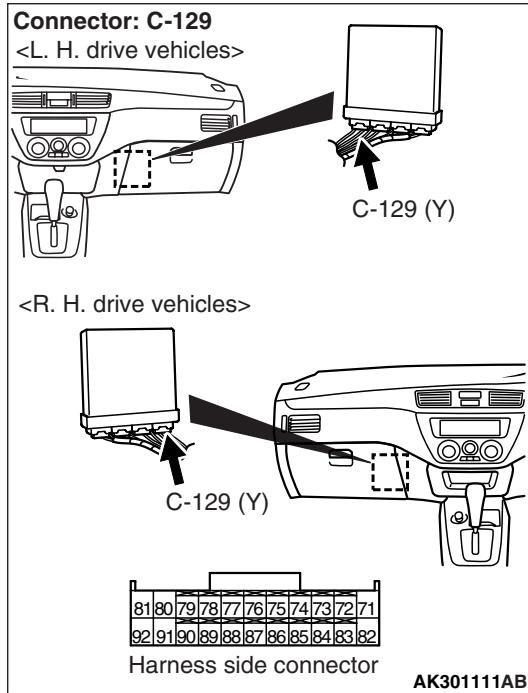

Q: Is the check result normal?

YES : Go to Step 7 .

NO : Repair or replace.

STEP 7. Check harness between B-116 (terminal No. 2) crank angle sensor connector and C-129 (terminal No. 89) engine-ECU <M/T> connector or C-124 (terminal No. 45) engine-A/T-ECU <A/T> connector.

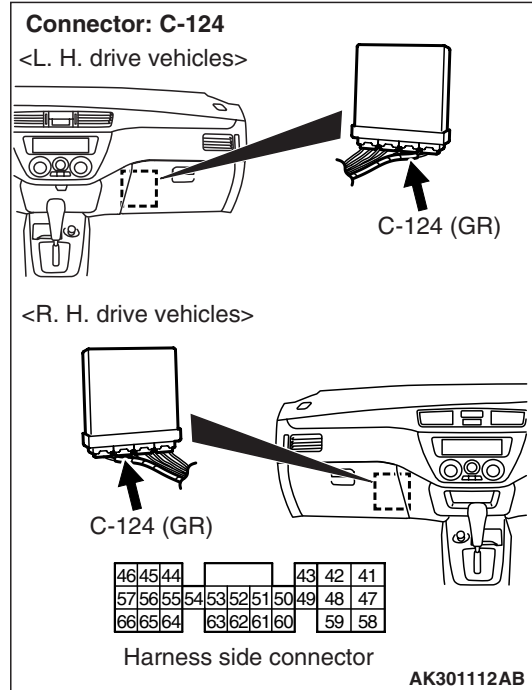
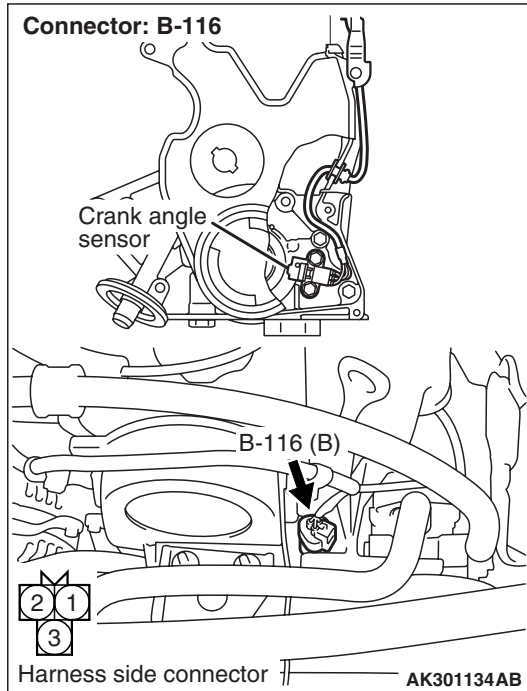

- Check output line for short circuit.

Q: Is the check result normal?

YES : Go to Step 8 .

NO : Repair.

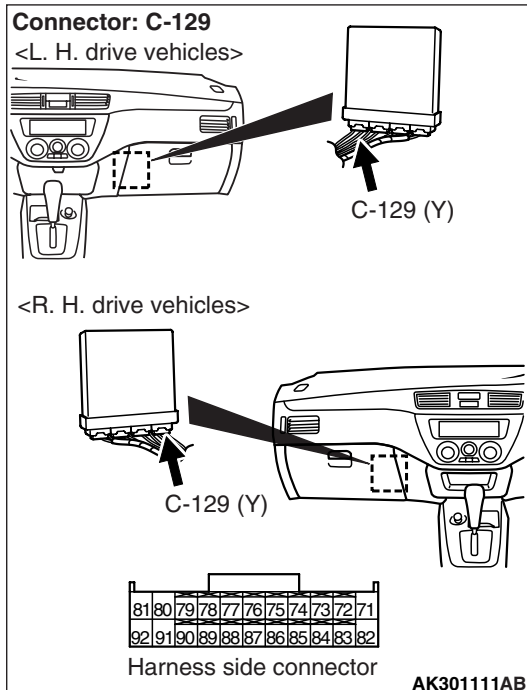

STEP 8. M.U.T.-II/III data list

- Refer to data list reference table [P.13A-376](#).
 - a. Item 22: Crank angle sensor

Q: Is the check result normal?

YES : Intermittent malfunction (Refer to GROUP 00 –How to Use Troubleshooting/Inspection Service Points [P.00-5](#)).

NO : Replace engine-ECU <M/T> or engine-A/T-ECU <A/T>.

STEP 9. Perform voltage measurement at B-116 crank angle sensor connector.

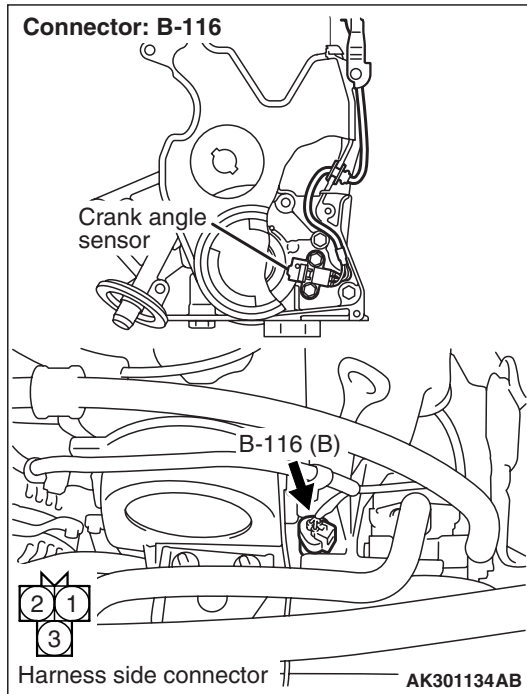

- Disconnect connector, and measure at harness side.
- Ignition switch: ON
- Voltage between terminal No. 3 and earth.

OK: System voltage

Q: Is the check result normal?

YES : Go to Step 11 .

NO : Go to Step 10 .

STEP 10. Connector check: B-16X engine control relay connector

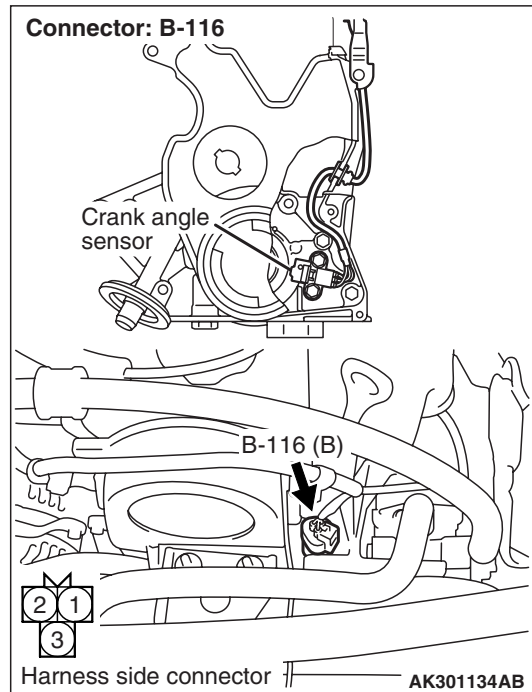
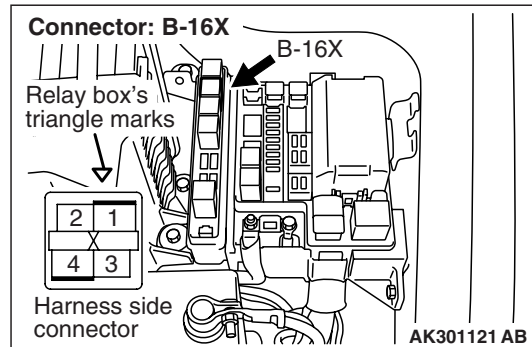

Q: Is the check result normal?

YES : Check and repair harness between B-116 (terminal No. 3) crank angle sensor connector and B-16X (terminal No. 4) engine control relay connector.

- Check power supply line for open/short circuit.

NO : Repair or replace.

STEP 11. Perform resistance measurement at B-116 crank angle sensor connector.

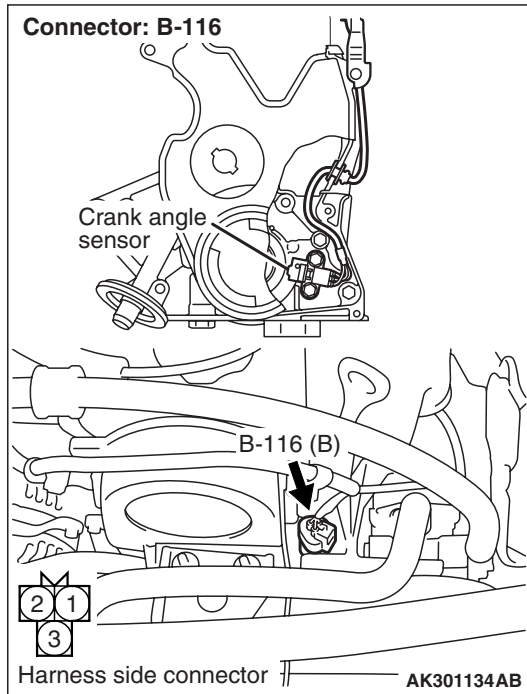

- Disconnect connector, and measure at harness side.
- Resistance between terminal No. 1 and earth.
OK: Continuity (2 Ω or less)

Q: Is the check result normal?

YES : Go to Step 14 .

NO : Go to Step 12 .

STEP 12. Connector check: C-125 engine-ECU <M/T> connector or C-122 engine-A/T-ECU <A/T> connector

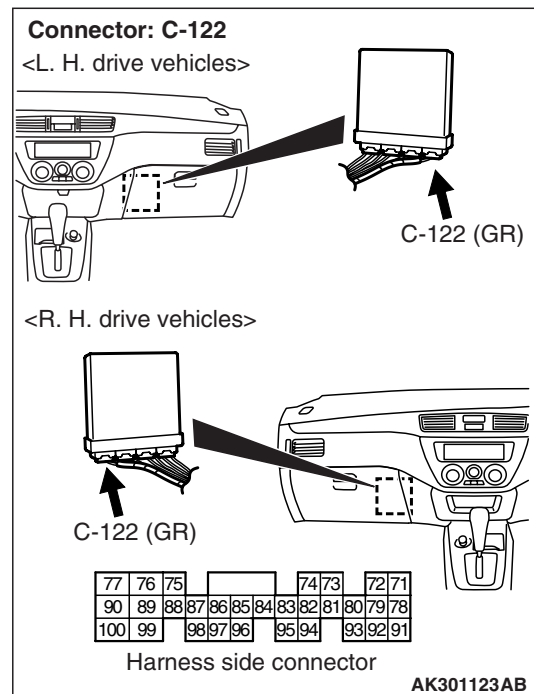
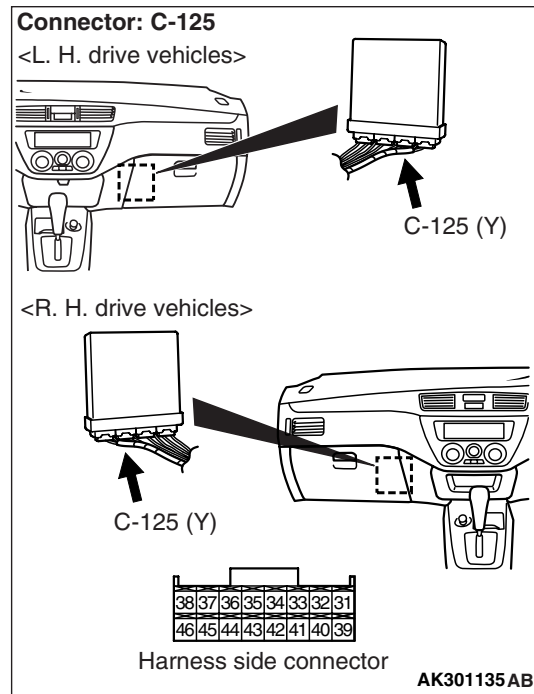

Q: Is the check result normal?

YES : Go to Step 13 .

NO : Repair or replace.

STEP 13. Check harness between B-116 (terminal No. 1) crank angle sensor connector and C-125 (terminal No. 40) engine-ECU <M/T> connector or C-122 (terminal No. 16) engine-A/T-ECU <A/T> connector.

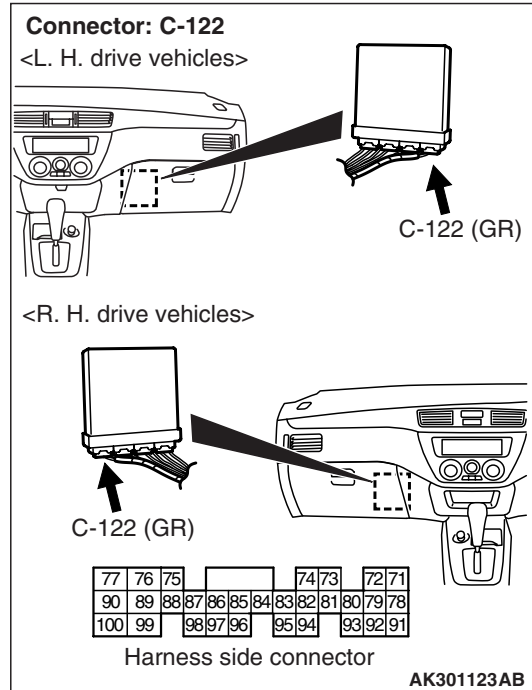
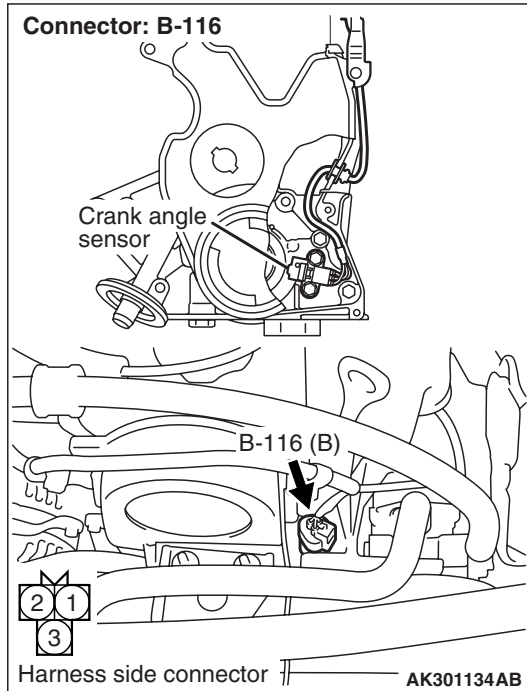

- Check earthing line for open circuit and damage.

Q: Is the check result normal?

YES : Go to Step 8 .

NO : Repair.

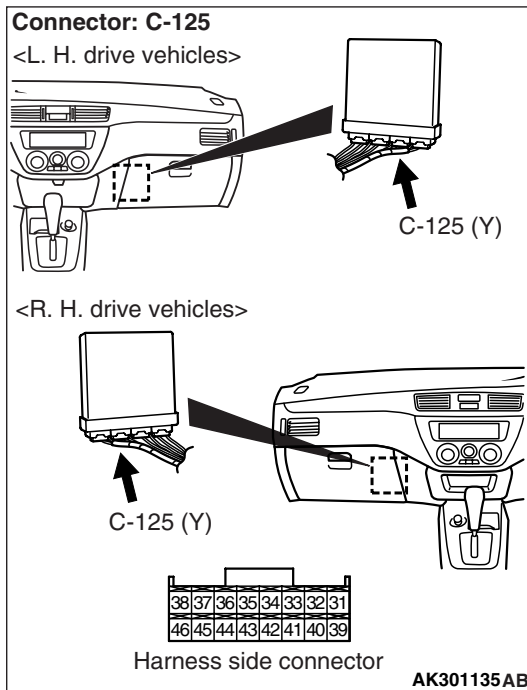

STEP 14. Perform output wavepattern measurement at B-116 crank angle sensor connector (Using oscilloscope).

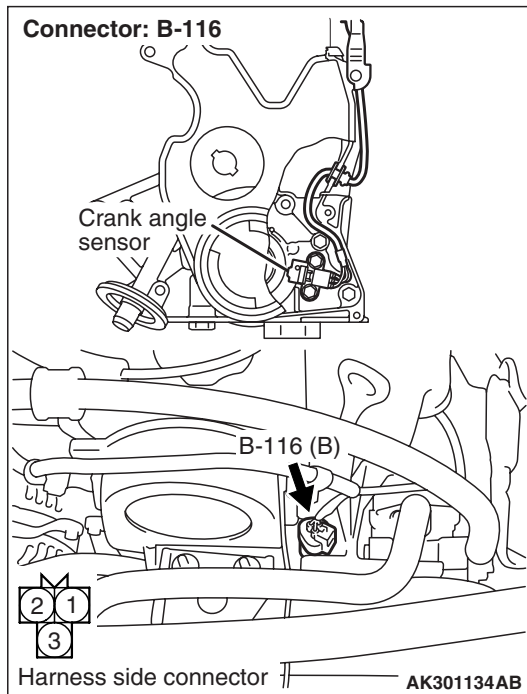

- Use special tool test harness (MD998478) to connect connector, and measure at pick-up harness.
- Engine: Idling
- Transmission: Neutral <M/T> or P range <A/T>
- Voltage between terminal No. 3 and earth.

OK: Waveforms should be displayed on Inspection procedure using an oscilloscope (Refer to P.13A-391), its maximum value should be 4.8 V or more, and its minimum value should be 0.6 V or less with no noise in waveform.

Q: Is the check result normal?

- YES :** Go to Step 8 .
NO : Go to Step 15 .

STEP 15. Connector check: B-16X engine control relay connector

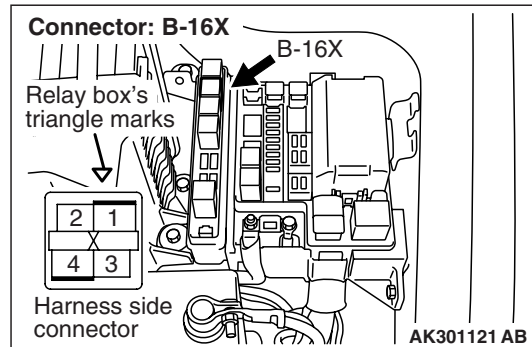

Q: Is the check result normal?

- YES :** Go to Step 16 .
NO : Repair or replace.

STEP 16. Check harness between B-116 (terminal No. 3) crank angle sensor connector and B-16X (terminal No. 4) engine control relay connector.

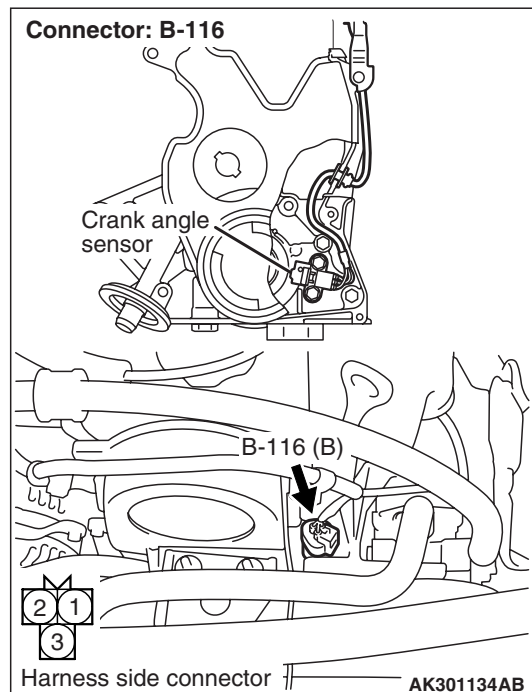

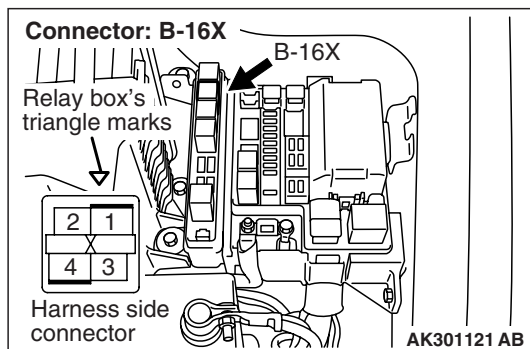

- Check power supply line for damage.

Q: Is the check result normal?

YES : Go to Step 17 .

NO : Repair.

STEP 17. Connector check: C-129 and C-125 engine-ECU <M/T> connector or C-124 and C-122 engine-A/T-ECU <A/T> connectors

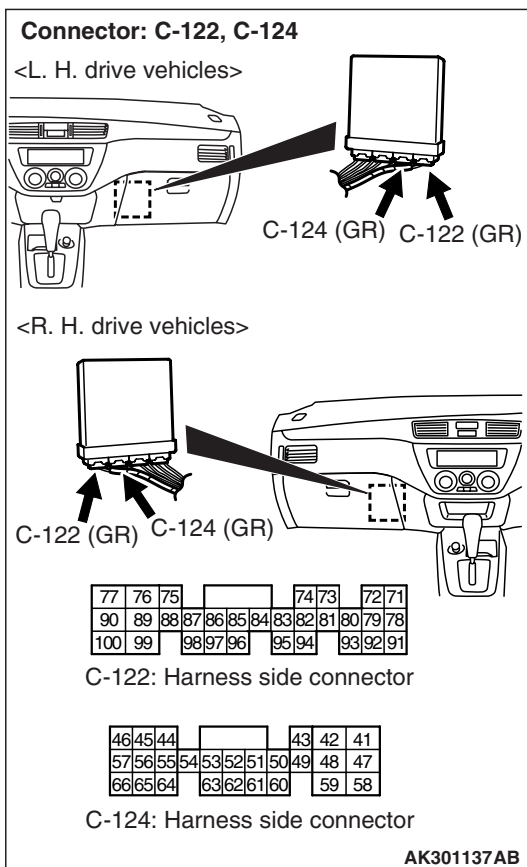
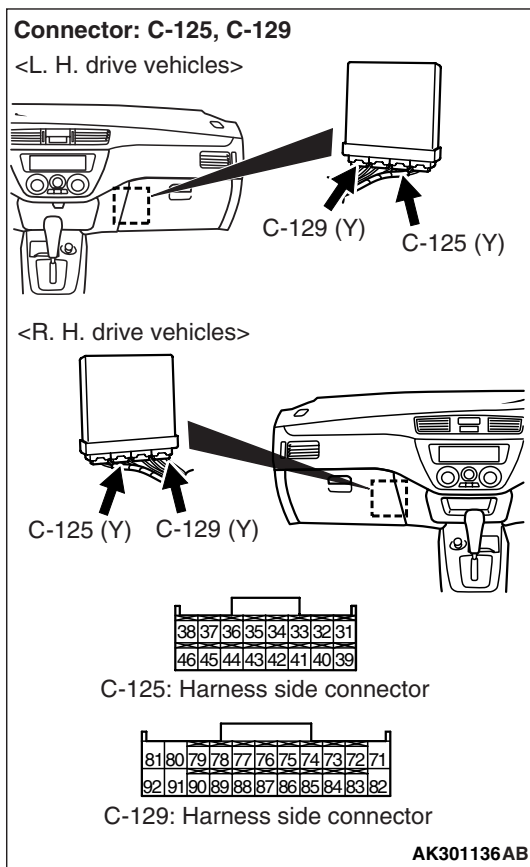

Q: Is the check result normal?

YES : Go to Step 18 .

NO : Repair or replace.

STEP 18. Check harness between B-116 (terminal No. 2) crank angle sensor connector and C-129 (terminal No. 89) engine-ECU <M/T> connector or C-124 (terminal No. 45) engine-A/T-ECU <A/T> connector.

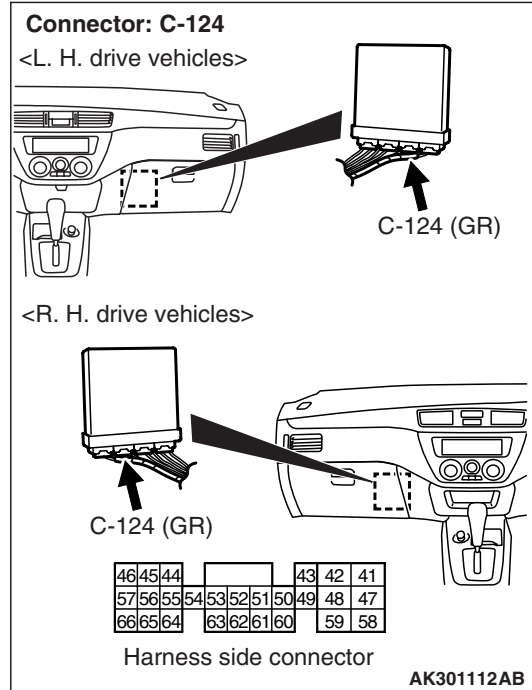
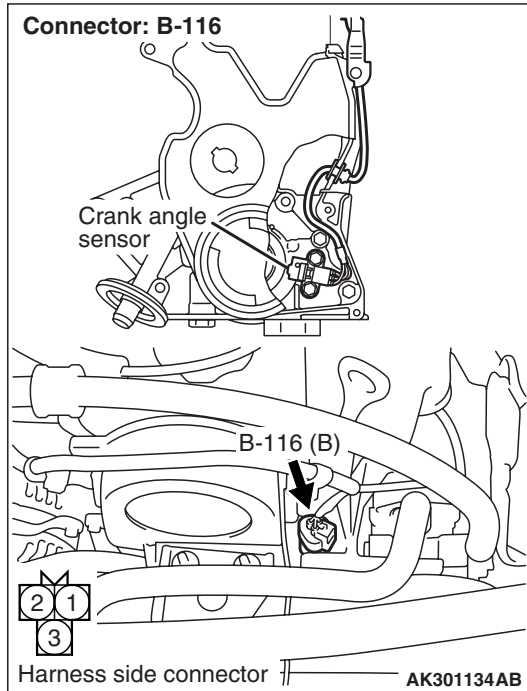

- Check output line for damage.

Q: Is the check result normal?

YES : Go to Step 19 .

NO : Repair.

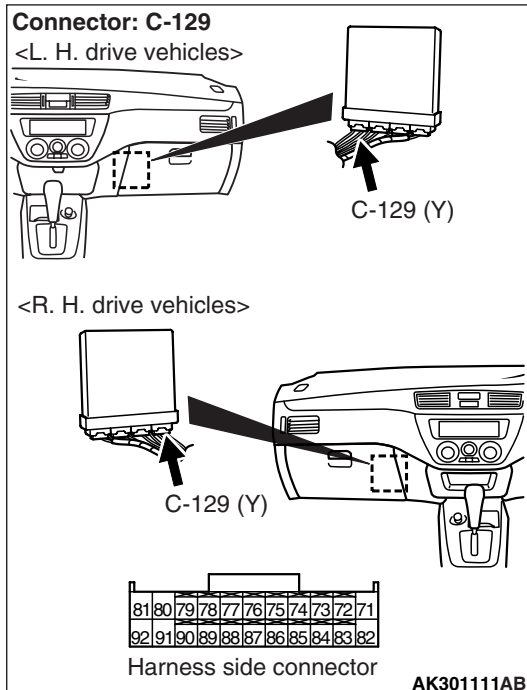

STEP 19. Check harness between B-116 (terminal No. 1) crank angle sensor connector and C-125 (terminal No. 40) engine-ECU <M/T> connector or C-122 (terminal No. 16) engine-A/T-ECU <A/T> connector.

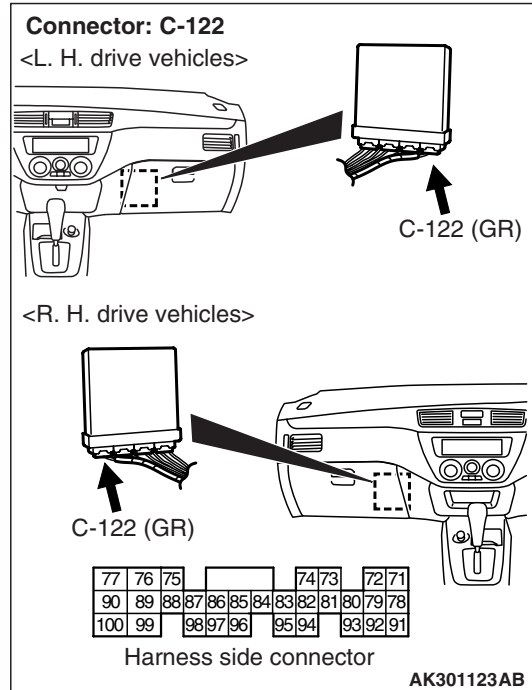
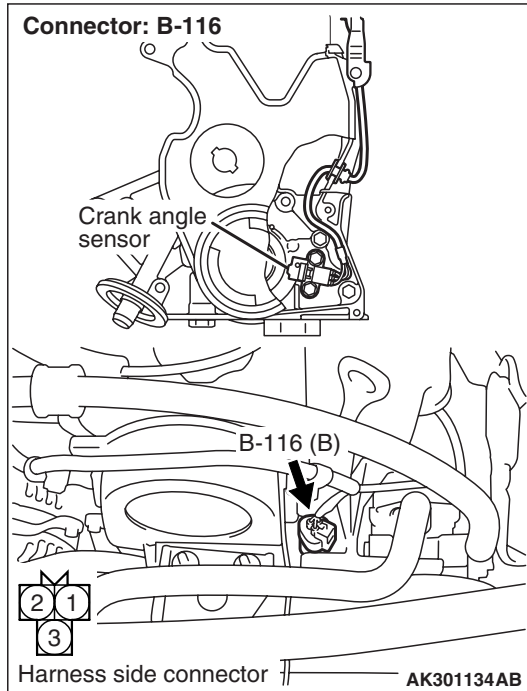

- Check earthing line for damage.

Q: Is the check result normal?

YES : Go to Step 20 .

NO : Repair.

STEP 20. Check the crankshaft sensing blade.

Q: Is the check result normal?

YES : Go to Step 21 .

NO : Replace the crankshaft sensing blade.

STEP 21. M.U.T.-II/III data list

- Refer to data list reference table [P.13A-376](#).
 - Item 22: Crank angle sensor

Q: Is the check result normal?

YES : Intermittent malfunction (Refer to GROUP 00 –How to Use Troubleshooting/Inspection Service Points [P.00-5](#)).

NO : Replace crank angle sensor.

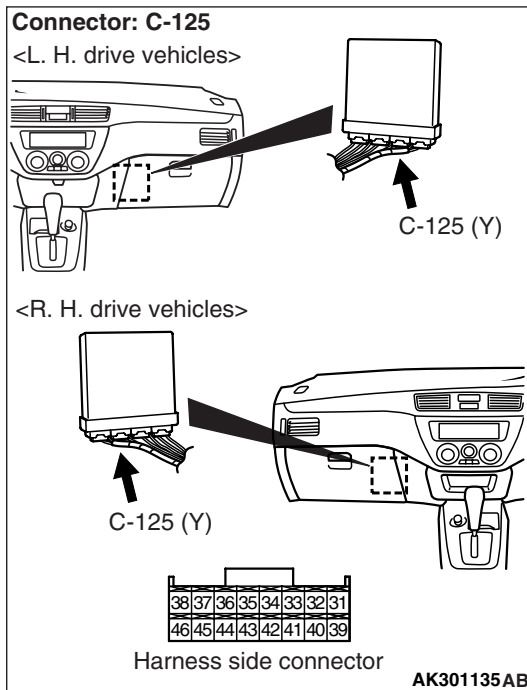

Code No. P0340: Camshaft Position Sensor System

Camshaft position sensor circuit

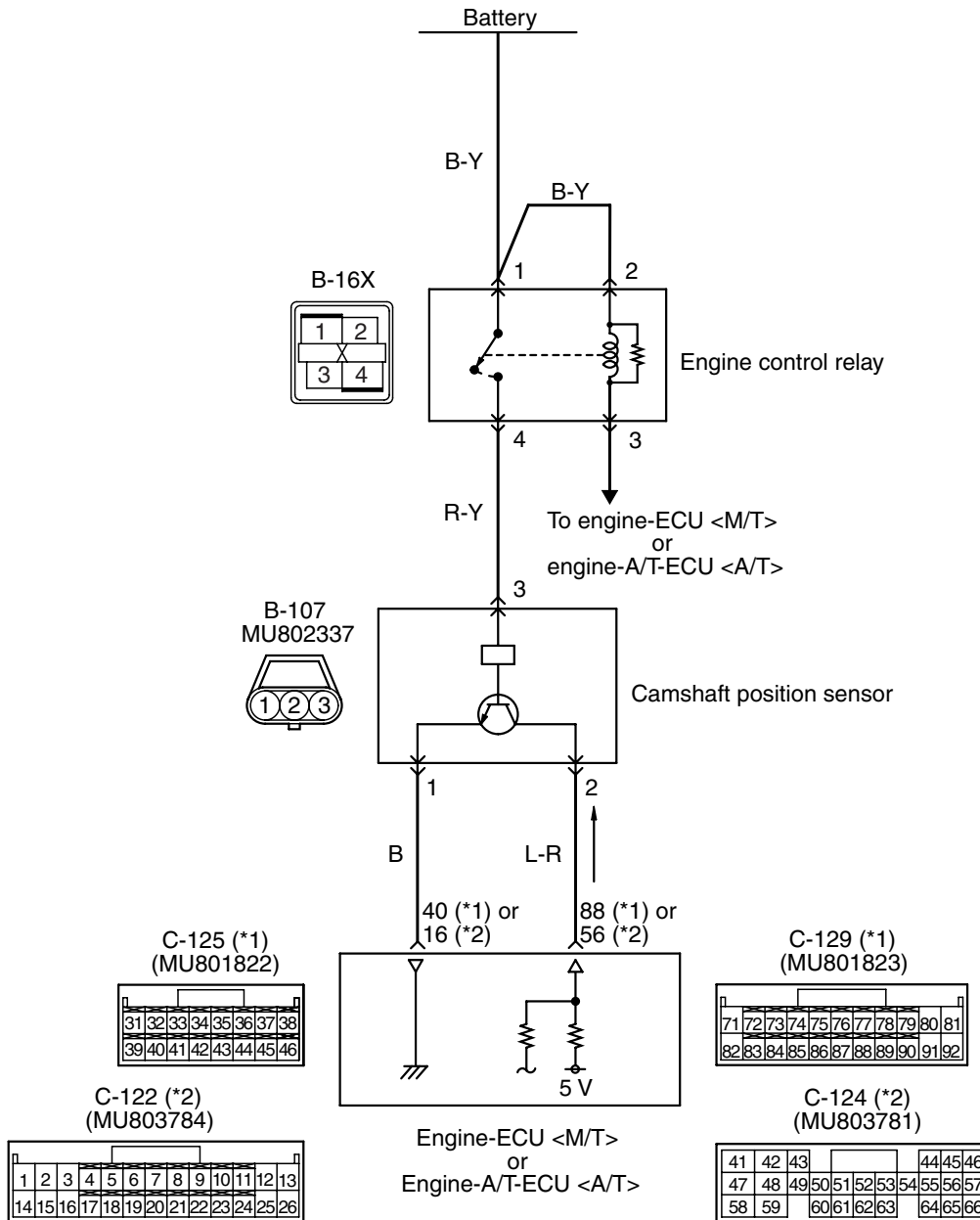

NOTE
*1: M/T
*2: A/T

Wire colour code
B: Black LG: Light green G: Green L: Blue W: White Y: Yellow SB: Sky blue BR: Brown O: Orange GR: Gray
R: Red P: Pink V: Violet

OPERATION

- Power is supplied to the camshaft position sensor (terminal No. 3) from the engine control relay (terminal No. 4) and is earthed to the engine-ECU (terminal No. 40) <M/T> or engine-A/T-ECU (terminal No. 16) <A/T> from the camshaft position sensor (terminal No. 1).
- A power voltage of 5 V is applied to the camshaft position sensor output terminal (terminal No. 2) from the engine-ECU (terminal No. 88) <M/T> or engine-A/T-ECU (terminal No. 56) <A/T>.

FUNCTION

- The camshaft position sensor detects the top dead centre on the compression stroke of the No. 1 cylinder and inputs a pulse signal to the engine-ECU <M/T> or engine-A/T-ECU <A/T>.

TROUBLE JUDGMENT**Check Condition**

- After the engine has started up.

Judgment Criterion

- The sensor output voltage remains unchanged (no pulse signal is inputted) for 2 seconds.

PROBABLE CAUSE

- Failed camshaft position sensor
- Open/short circuit in camshaft position sensor circuit or loose connector contact
- Failed engine-ECU <M/T>
- Failed engine-A/T-ECU <A/T>

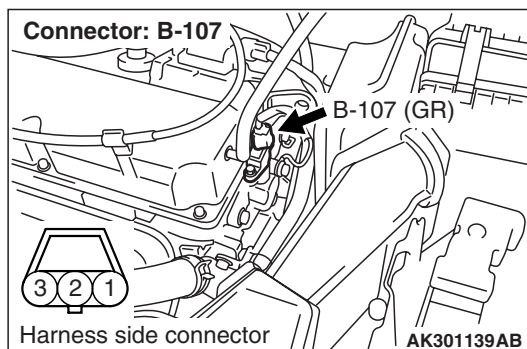
DIAGNOSIS PROCEDURE**STEP 1. Connector check: B-107 camshaft position sensor connector**

Q: Is the check result normal?

- YES :** Go to Step 2 .
NO : Repair or replace.

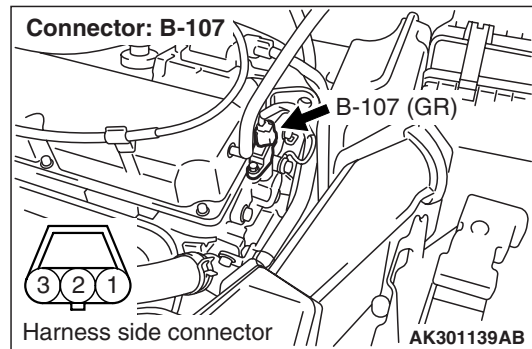
STEP 2. Perform voltage measurement at B-107 camshaft position sensor connector.

- Disconnect connector, and measure at harness side.
- Ignition switch: ON
- Voltage between terminal No. 3 and earth.

OK: System voltage

Q: Is the check result normal?

- YES :** Go to Step 4 .
NO : Go to Step 3 .

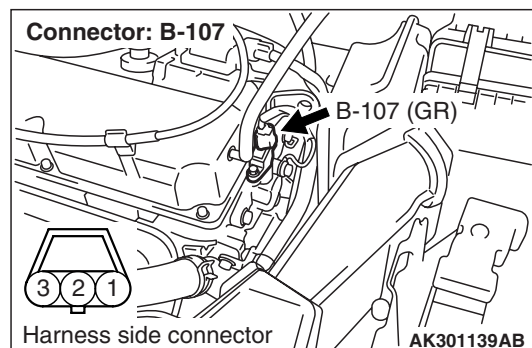
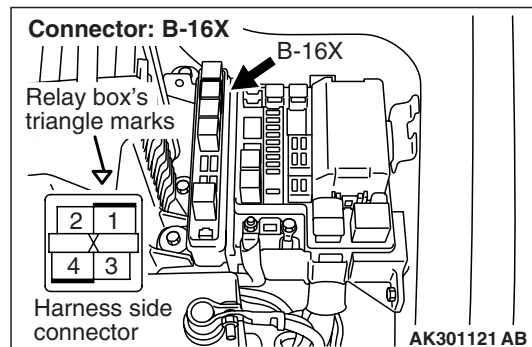
STEP 3. Connector check: B-16X engine control relay connector

Q: Is the check result normal?

YES : Check and repair harness between B-107 (terminal No. 3) camshaft position sensor connector and B-16X (terminal No. 4) engine control relay connector.

- Check power supply line for open/short circuit.

NO : Repair or replace.

STEP 4. Perform voltage measurement at B-107 camshaft position sensor connector.

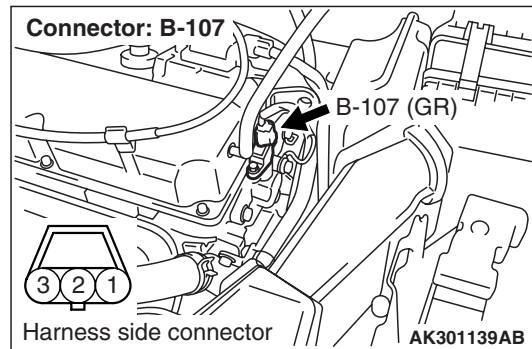

- Disconnect connector, and measure at harness side.
- Ignition switch: ON
- Voltage between terminal No. 2 and earth.

OK: 4.9 – 5.1 V

Q: Is the check result normal?

YES : Go to Step 10 .

NO : Go to Step 5 .

STEP 5. Perform voltage measurement at C-129 engine-ECU <M/T> connector or C-124 engine-A/T-ECU <A/T> connector.

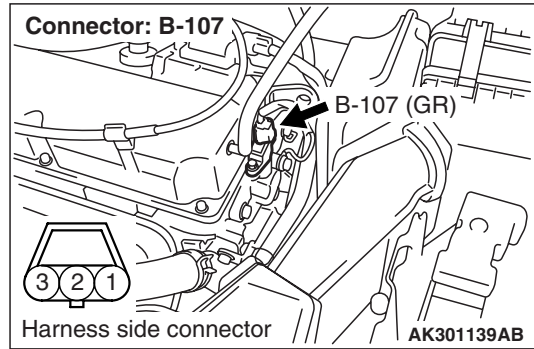
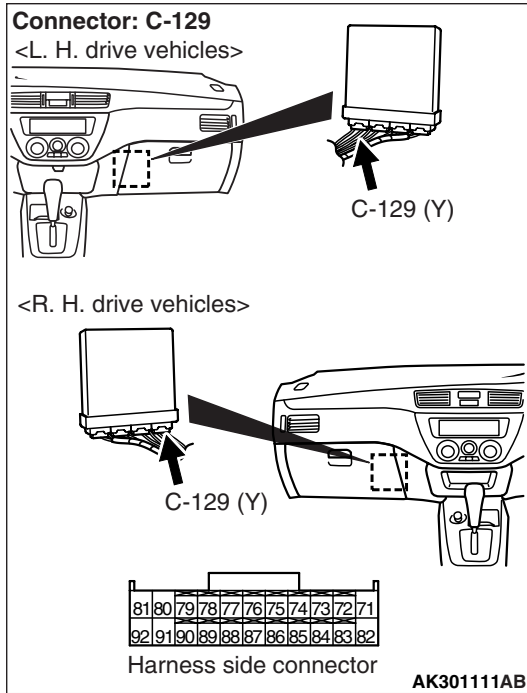

- Measure engine-ECU <M/T> or engine-A/T-ECU <A/T> terminal voltage.
- Disconnect B-107 camshaft position sensor connector.
- Ignition switch: ON
- Voltage between terminal No. 88 <M/T> or terminal No. 56 <A/T> and earth.

OK: 4.9 – 5.1 V

Q: Is the check result normal?

YES : Go to Step 6 .

NO : Go to Step 7 .

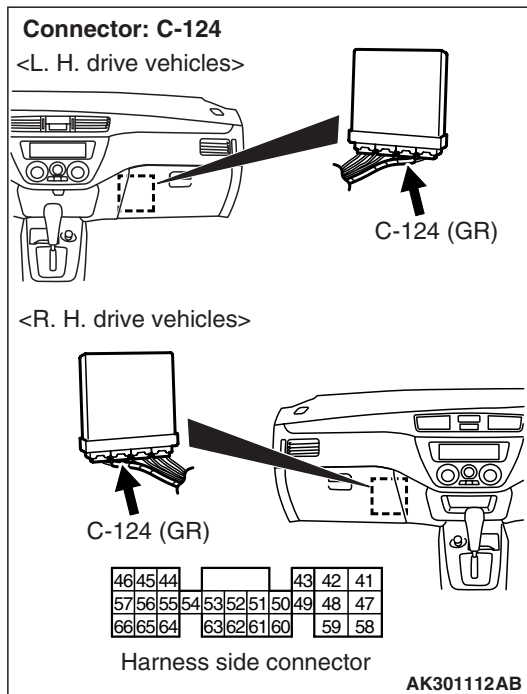

STEP 6. Connector check: C-129 engine-ECU connector

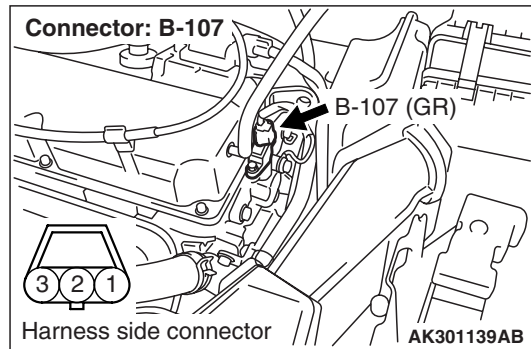
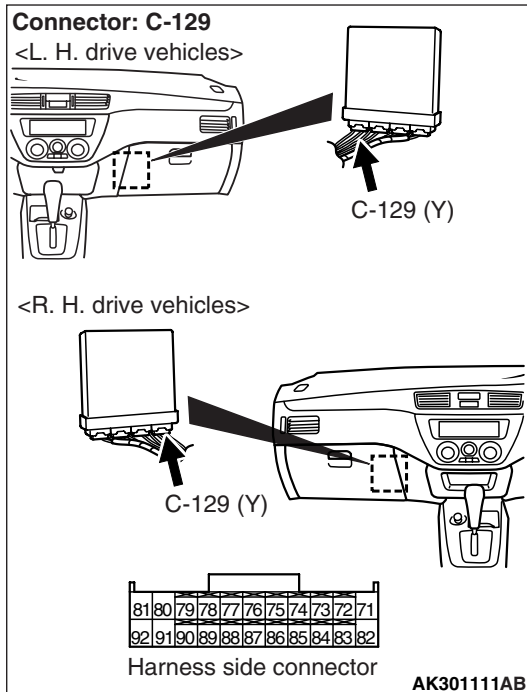

Q: Is the check result normal?

YES : Check and repair harness between B-107 (terminal No. 2) camshaft position sensor connector and C-129 (terminal No. 88) engine-ECU <M/T> connector or C-124 (terminal No. 56) engine-A/T-ECU <A/T> connector.

- Check output line for open circuit.

NO : Repair or replace.

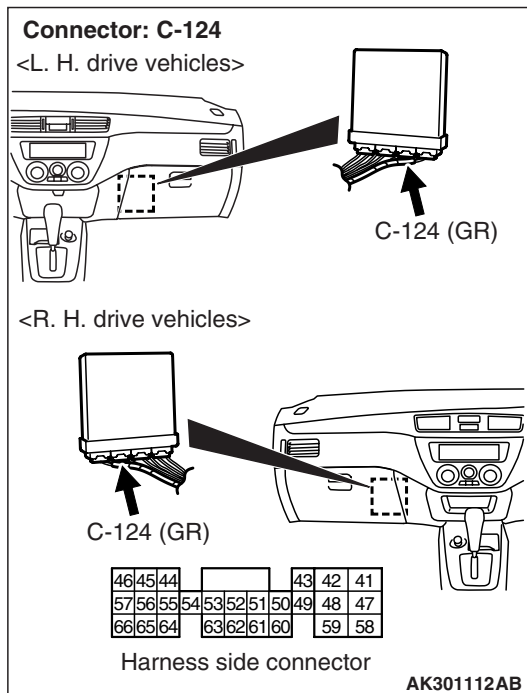

**STEP 7. Connector check: C-129 engine-ECU
<M/T> connector or C-122 engine-A/T-ECU <A/T>
connector**

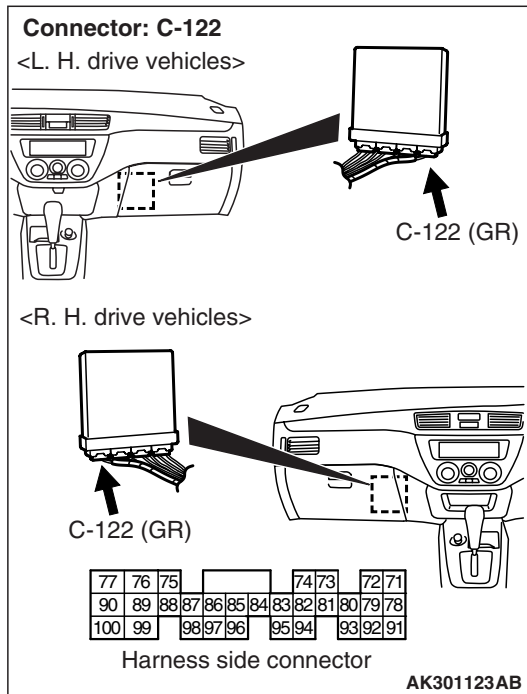
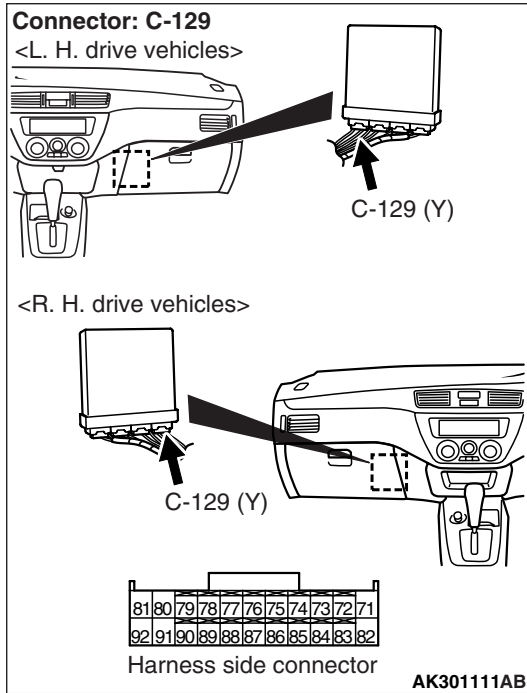

Q: Is the check result normal?

YES : Go to Step 8 .

NO : Repair or replace.

STEP 8. Check harness between B-107 (terminal No. 2) camshaft position sensor connector and C-129 (terminal No. 88) engine-ECU <M/T> connector or C-124 (terminal No. 56) engine-A/T-ECU <A/T> connector.

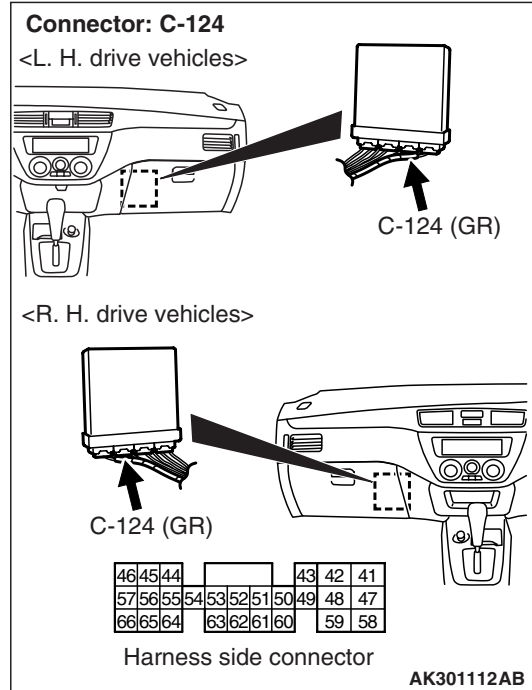
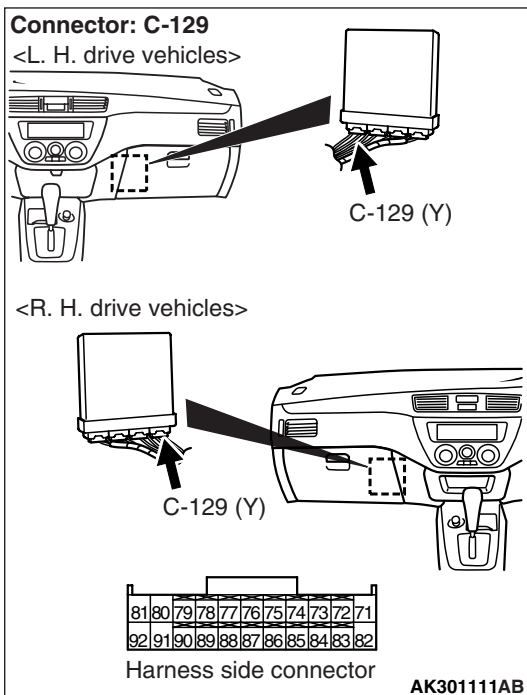
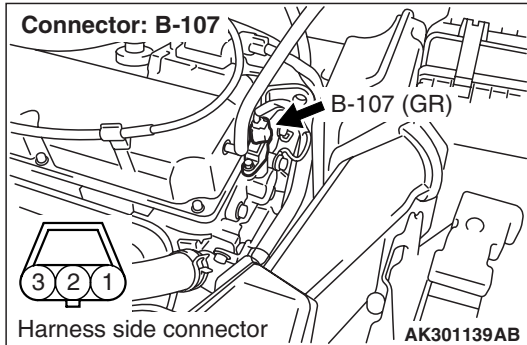

- Check output line for short circuit.

Q: Is the check result normal?

YES : Go to Step 9 .

NO : Repair.

STEP 9. Check the trouble symptoms.

Q: Does trouble symptom persist?

YES : Replace engine-ECU <M/T> or engine-A/T-ECU <A/T>.

NO : Intermittent malfunction (Refer to GROUP 00 –How to Use Troubleshooting/Inspection Service Points P.00-5).

STEP 10. Perform resistance measurement at B-107 camshaft position sensor connector.

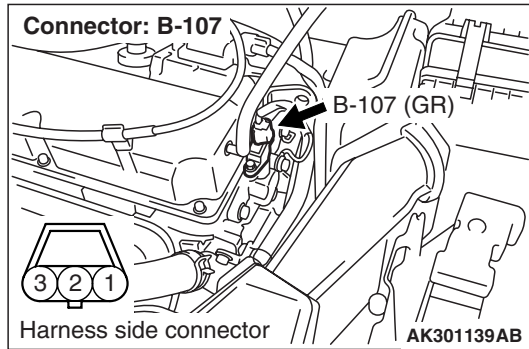

- Disconnect connector, and measure at harness side.
 - Resistance between terminal No. 1 and earth.
- OK: Continuity (2 Ω or less)**

Q: Is the check result normal?
YES : Go to Step 13 .
NO : Go to Step 11 .

STEP 11. Connector check: C-125 engine-ECU <M/T> connector or C-122 engine-A/T-ECU <A/T> connector

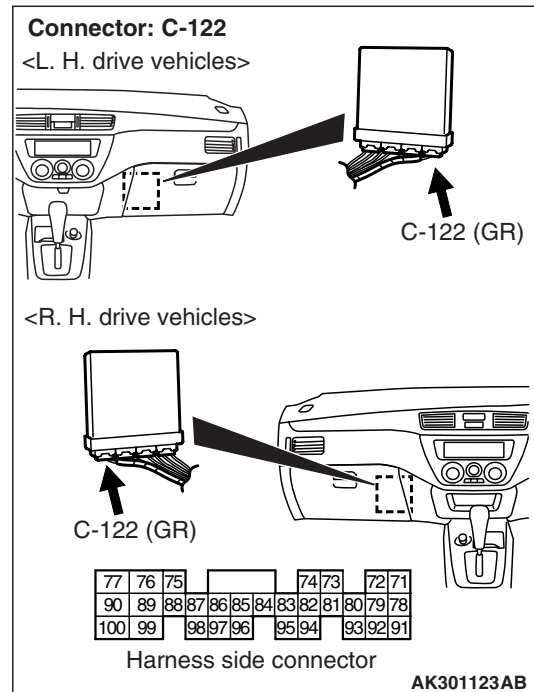
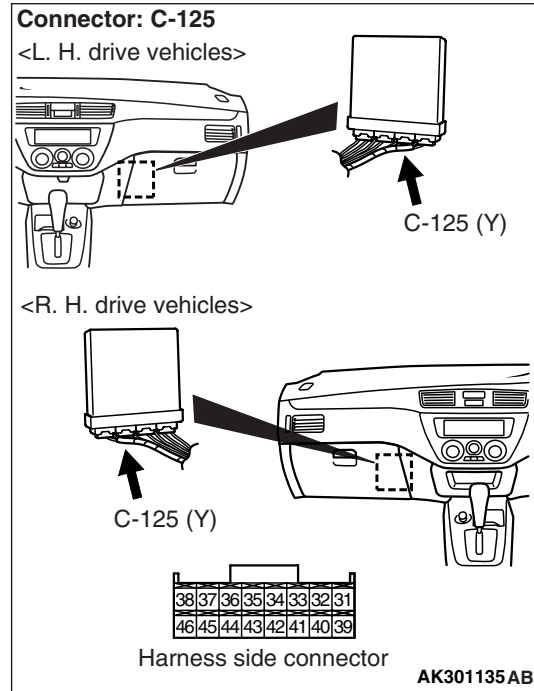

Q: Is the check result normal?
YES : Go to Step 12 .
NO : Repair or replace.

STEP 12. Check harness between B-107 (terminal No. 1) camshaft position sensor connector and C-125 (terminal No. 40) engine-ECU <M/T> connector or C-122 (terminal No. 16) engine-A/T-ECU <A/T> connector.

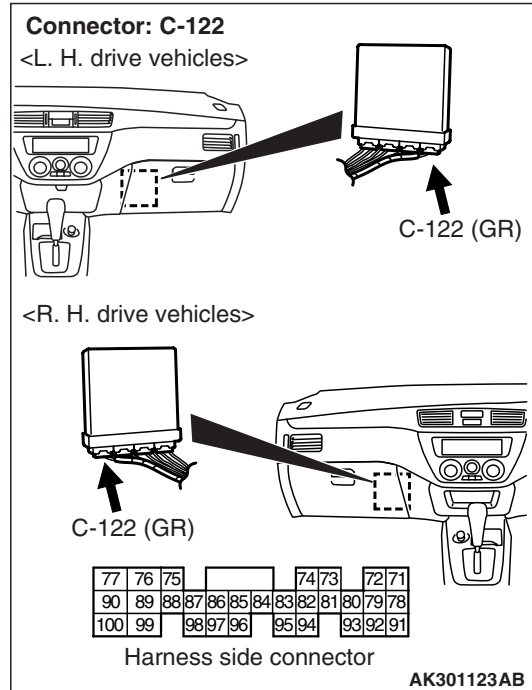
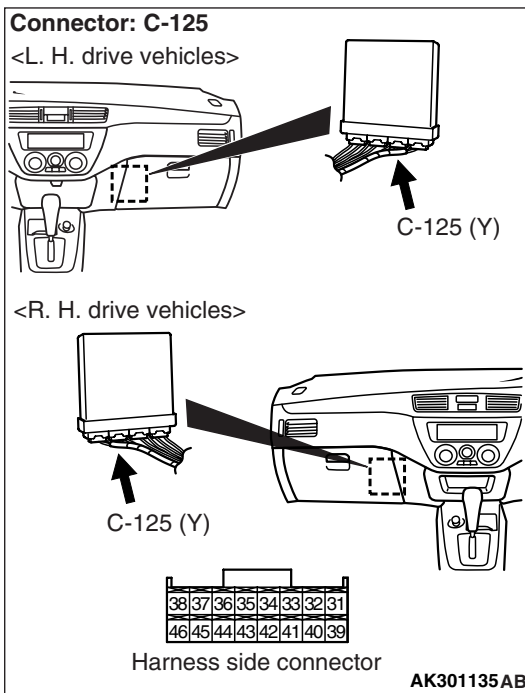
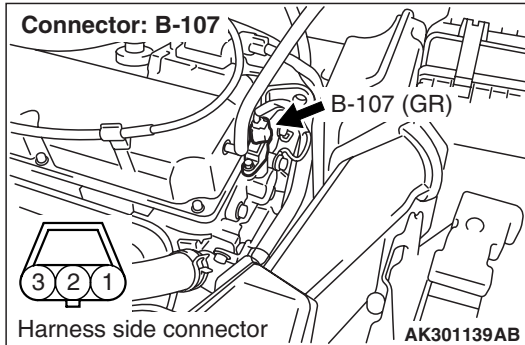

- Check earthing line for open circuit and damage.

Q: Is the check result normal?

YES : Go to Step 9 .

NO : Repair.

STEP 13. Perform output wavpattern measurement at B-107 camshaft position sensor connector (Using oscilloscope).

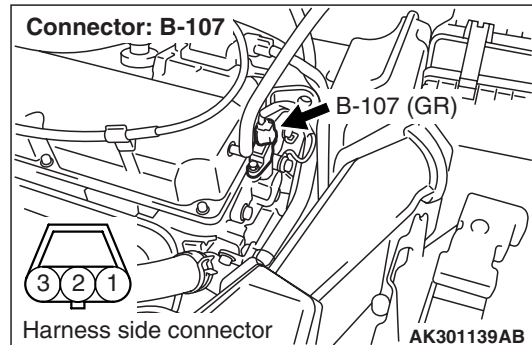

- Use special tool test harness (MB991709) to connect connector, and measure at pick-up harness.
- Engine: Idling
- Transmission: Neutral <M/T> or P range <A/T>
- Voltage between terminal No. 3 and earth.

OK: Waveforms should be displayed on Inspection procedure using an oscilloscope (Refer to P.13A-391), its maximum value should be 4.8 V or more, and its minimum value should be 0.6 V or less with no noise in waveform.

Q: Is the check result normal?

YES : Go to Step 9 .

NO : Go to Step 14 .

STEP 14. Connector check: B-16X engine control relay connector.

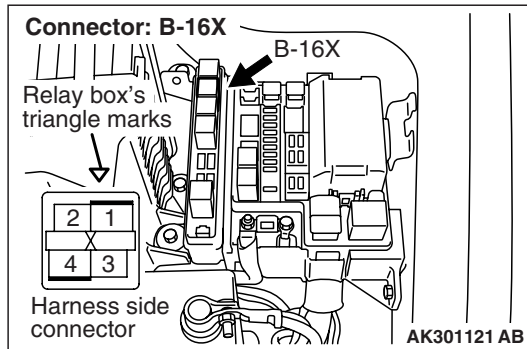

Q: Is the check result normal?

YES : Go to Step 15 .

NO : Repair or replace.

STEP 15. Check harness between B-107 (terminal No. 3) camshaft position sensor connector and B-16X (terminal No. 4) engine control relay connector.

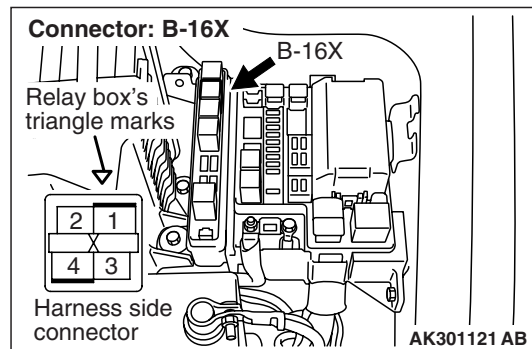
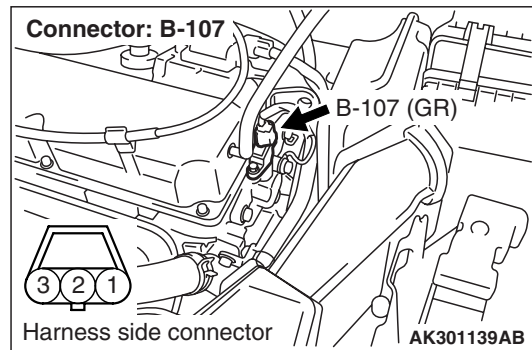

- Check power supply line for damage.

Q: Is the check result normal?

YES : Go to Step 16 .

NO : Repair.

STEP 16. Connector check: C-129 and C-125 engine-ECU <M/T> connector or C-124 and C-122 engine-A/T-ECU <A/T> connectors

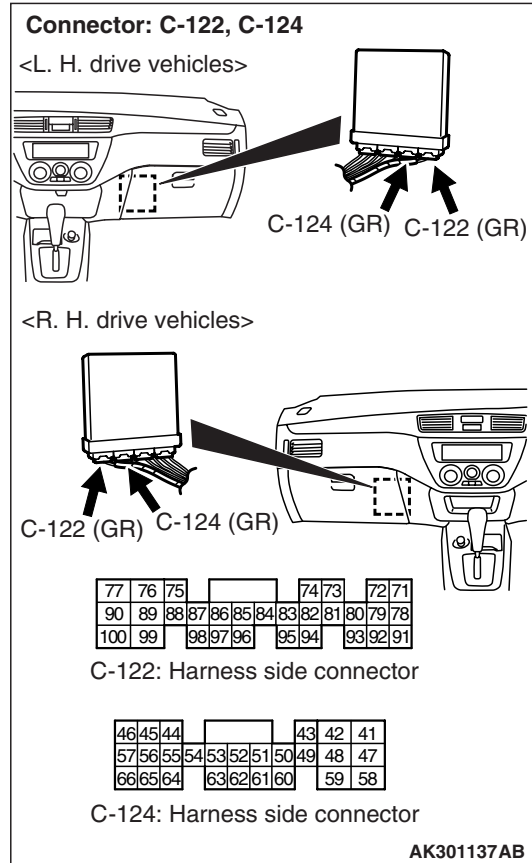
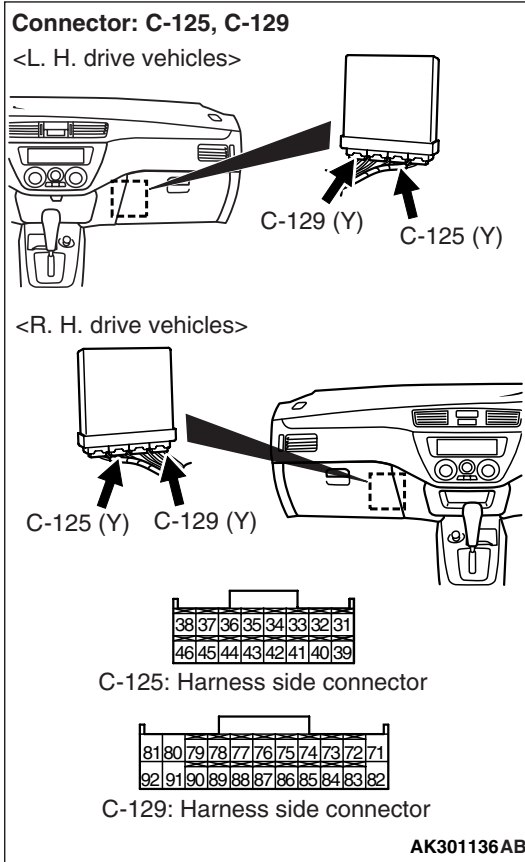

Q: Is the check result normal?
YES : Go to Step 17 .
NO : Repair or replace.

STEP 17. Check harness between B-107 (terminal No. 2) camshaft position sensor connector and C-129 (terminal No. 88) engine-ECU <M/T> connector or C-124 (terminal No. 56) engine-A/T-ECU <A/T> connector.

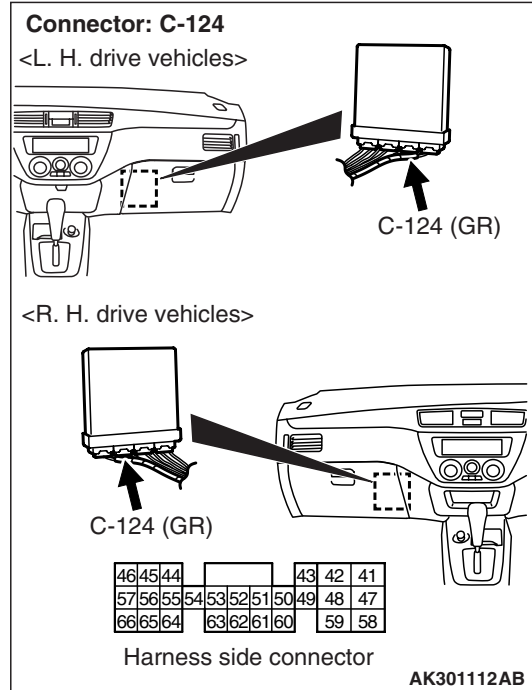
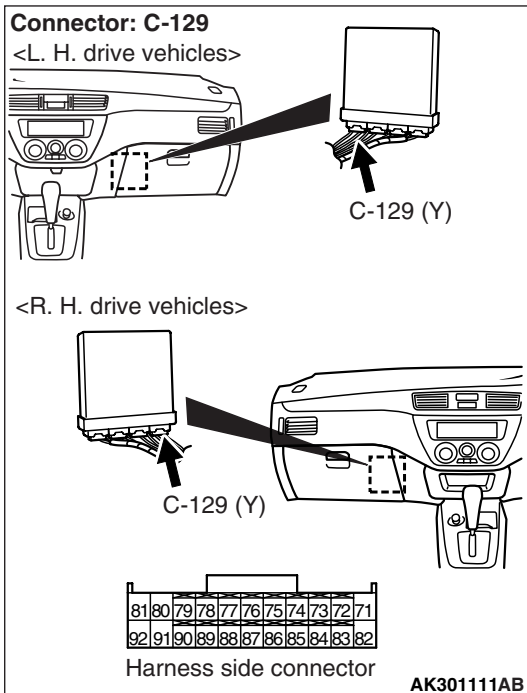
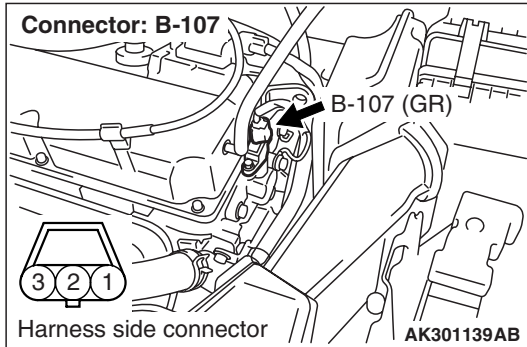

- Check output line for damage.

Q: Is the check result normal?

YES : Go to Step 18 .

NO : Repair.

STEP 18. Check harness between B-107 (terminal No. 1) camshaft position sensor connector and C-125 (terminal No. 40) engine-ECU <M/T> connector or C-122 (terminal No. 16) engine-A/T-ECU <A/T> connector.

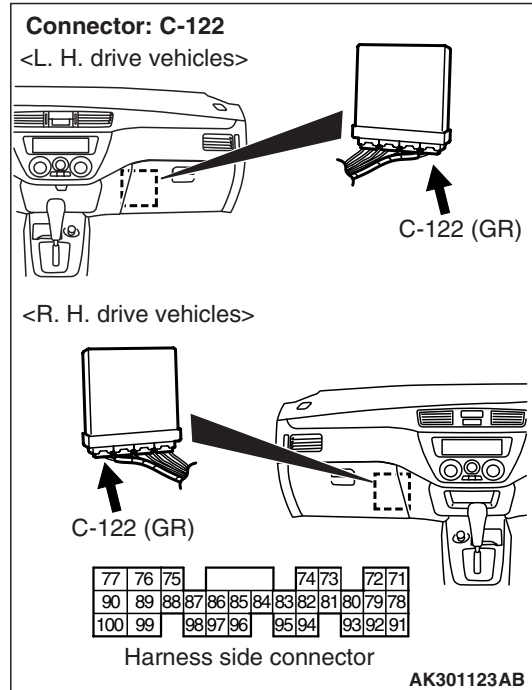
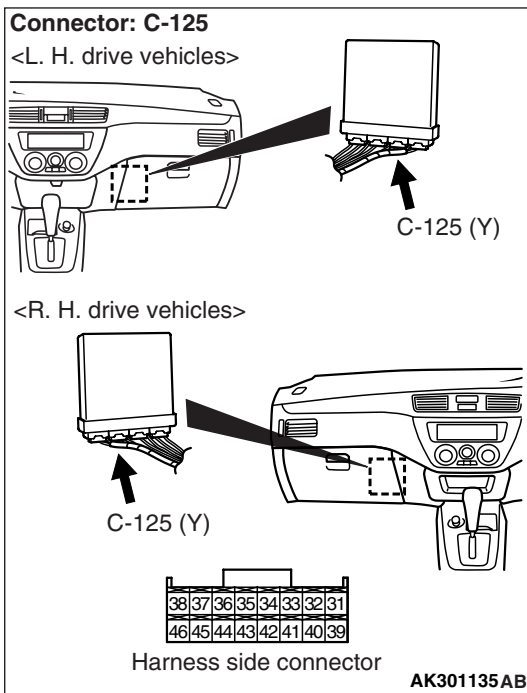
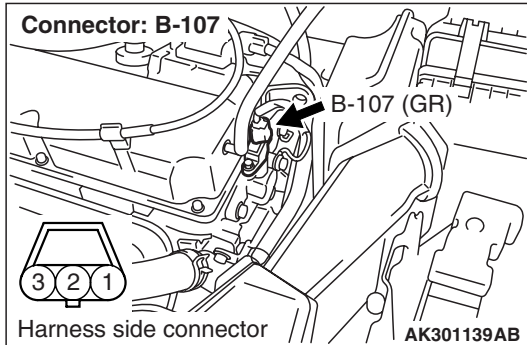

- Check earthing line for damage.

Q: Is the check result normal?

YES : Go to Step 19 .

NO : Repair.

STEP 19. Check camshaft position sensing cylinder.

Q: Is the check result normal?

YES : Go to Step 20 .

NO : Replace camshaft position sensing cylinder.

STEP 20. Check the trouble symptoms.

Q: Does trouble symptom persist?

YES : Replace camshaft position sensor.

NO : Intermittent malfunction (Refer to GROUP 00 –How to Use Troubleshooting/Inspection Service Points [P.00-5](#)).

Code No. P0403: EGR Control Solenoid Valve System

EGR control solenoid valve circuit

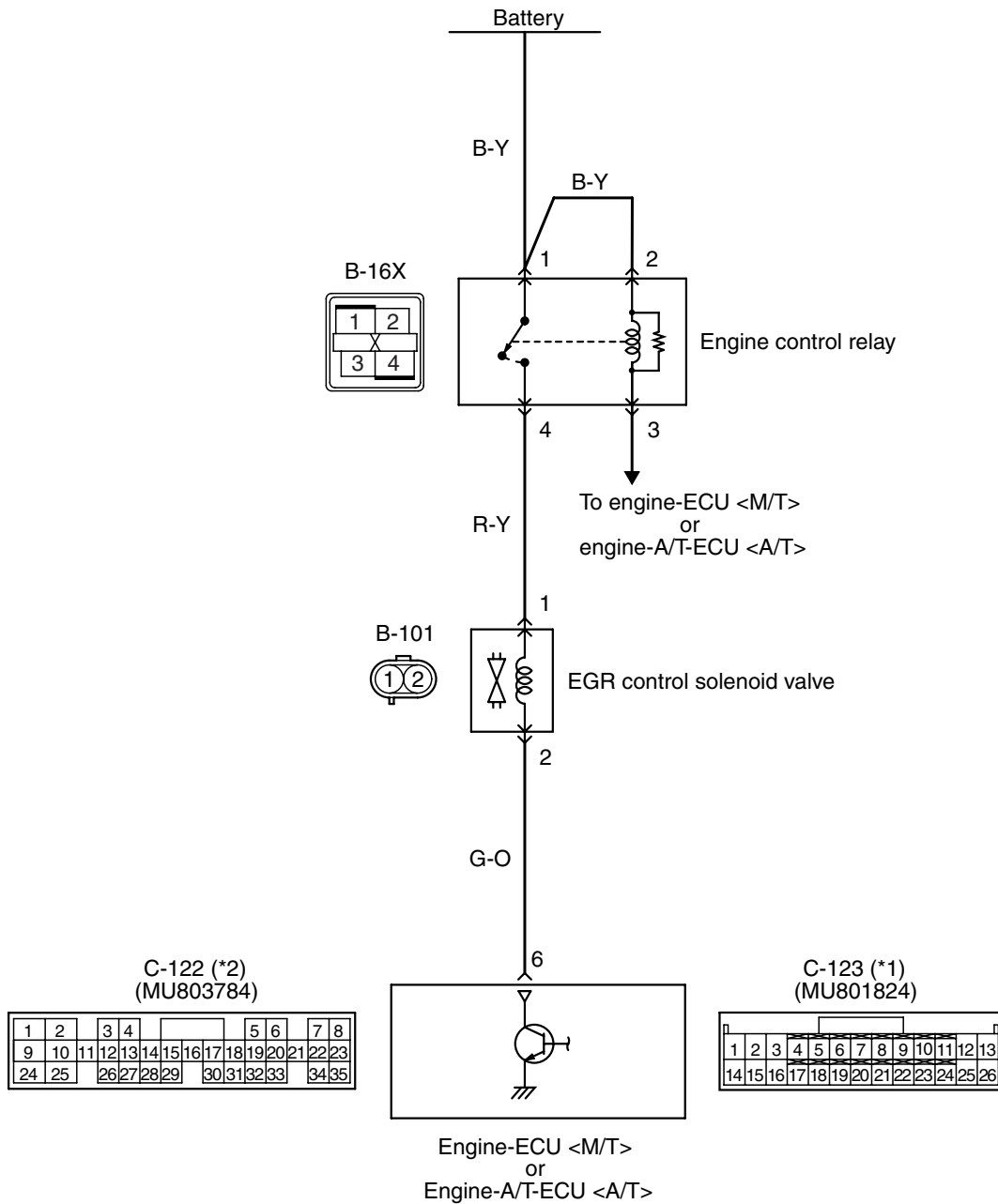

NOTE
*1: M/T
*2: A/T

Wire colour code
B: Black LG: Light green G: Green L: Blue W: White Y: Yellow SB: Sky blue BR: Brown O: Orange GR: Gray
R: Red P: Pink V: Violet

AK401354AB

OPERATION

- Power is supplied to the EGR control solenoid valve (terminal No. 1) from the engine control relay (terminal No. 4).
- The engine-ECU (terminal No. 6) <M/T> or engine-A/T-ECU (terminal No. 6) <A/T> makes the power transistor in the unit be in "ON", and that makes currents go on the EGR control solenoid valve (terminal No. 2).

FUNCTION

- In response to the signal from the engine-ECU <M/T> or engine-A/T-ECU <A/T>, the EGR control solenoid valve controls the operation of the EGR valve.

TROUBLE JUDGMENT

Check Conditions

- Ignition switch: ON
- The battery voltage is 10 V or more.

Judgment Criterion

- If the off surge voltage from the motor coil is not generated when the EGR valve control motor is driven.

PROBABLE CAUSE

- Failed EGR control solenoid valve
- Open/short circuit in EGR control solenoid valve circuit or loose connector contact
- Failed engine-ECU <M/T>
- Failed engine-A/T-ECU <A/T>

DIAGNOSIS PROCEDURE

STEP 1. M.U.T.-II/III actuator test

- Refer to actuator test reference table [P.13A-383](#).
 - Item 10: EGR control solenoid valve
 - OK: Operating sound can be heard and the valve vibrates.**

Q: Is the check result normal?

- YES :** Intermittent malfunction (Refer to GROUP 00 –How to Use Troubleshooting/Inspection Service Points [P.00-5](#)).
- NO :** Go to Step 2 .

STEP 2. Connector check: B-101 EGR control solenoid valve connector

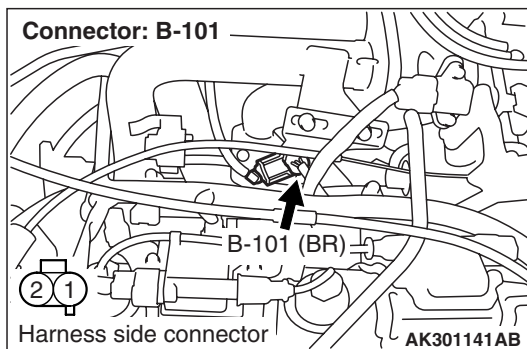

Q: Is the check result normal?

- YES :** Go to Step 3 .
- NO :** Repair or replace.

STEP 3. Perform resistance measurement at B-101 EGR control solenoid valve connector.

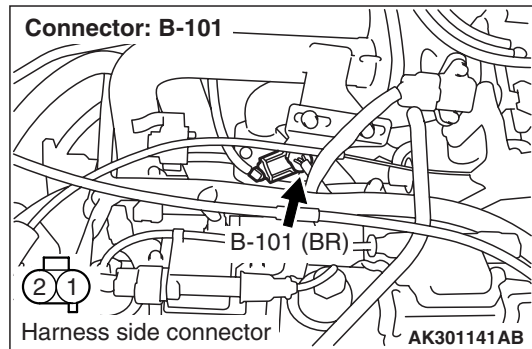

- Disconnect connector, and measure at solenoid valve side.
- Resistance between terminal No. 1 and No. 2.
 - OK: 29 – 35 Ω (at 20° C)**

Q: Is the check result normal?

- YES :** Go to Step 4 .
- NO :** Replace EGR control solenoid valve.

STEP 4. Perform voltage measurement at B-101 EGR control solenoid valve connector.

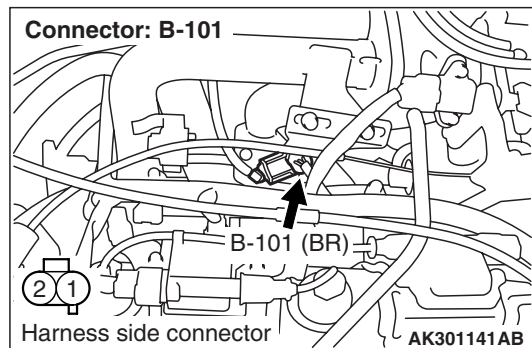

- Disconnect connector, and measure at harness side.
- Ignition switch: ON
- Voltage between terminal No. 1 and earth.
 - OK: System voltage**

Q: Is the check result normal?

- YES :** Go to Step 6 .
- NO :** Go to Step 5 .

STEP 5. Connector check: B-16X engine control relay connector

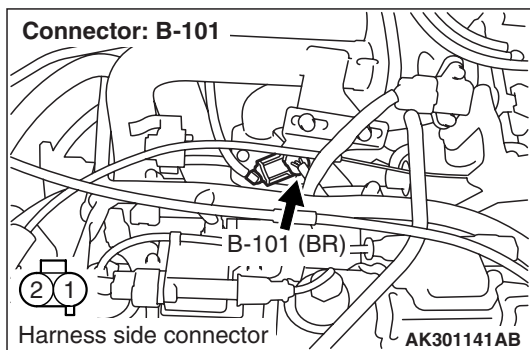
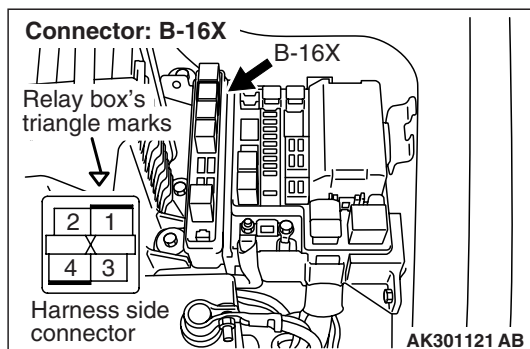

Q: Is the check result normal?

YES : Check and repair harness between B-101 (terminal No. 1) EGR control solenoid valve connector and B-16X (terminal No. 4) engine control relay connector.

- Check power supply line for open/short circuit.

NO : Repair or replace.

STEP 6. Perform voltage measurement at C-123 engine-ECU <M/T> connector or C-122 engine-A/T-ECU <A/T> connector.

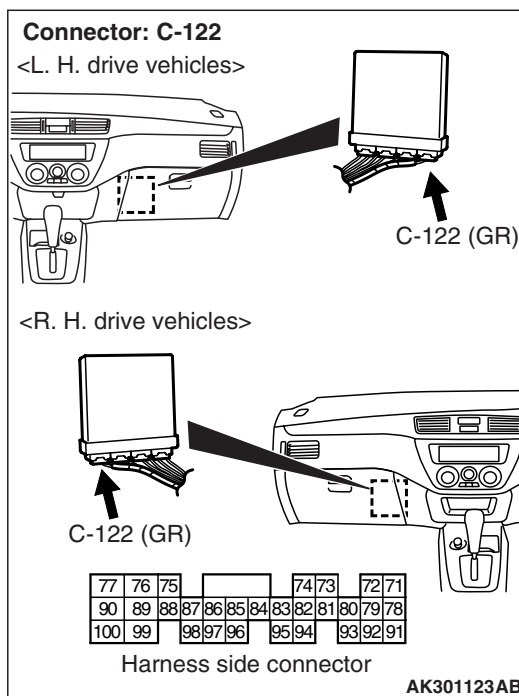
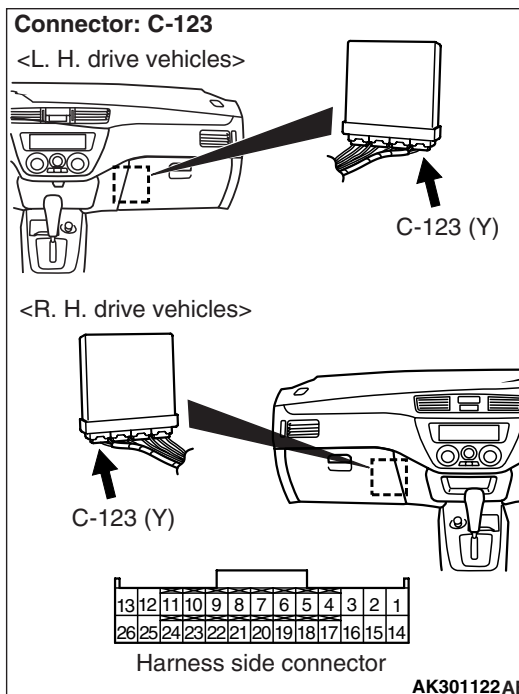

- Disconnect connector, and measure at harness side.
- Ignition switch: ON
- Voltage between terminal No. 6 and earth.

OK: System voltage

Q: Is the check result normal?

YES : Go to Step 8 .

NO : Go to Step 7 .

STEP 7. Connector check: C-123 engine-ECU <M/T> connector or C-122 engine-A/T-ECU <A/T> connector

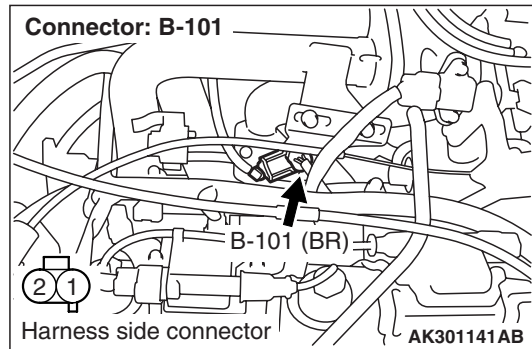
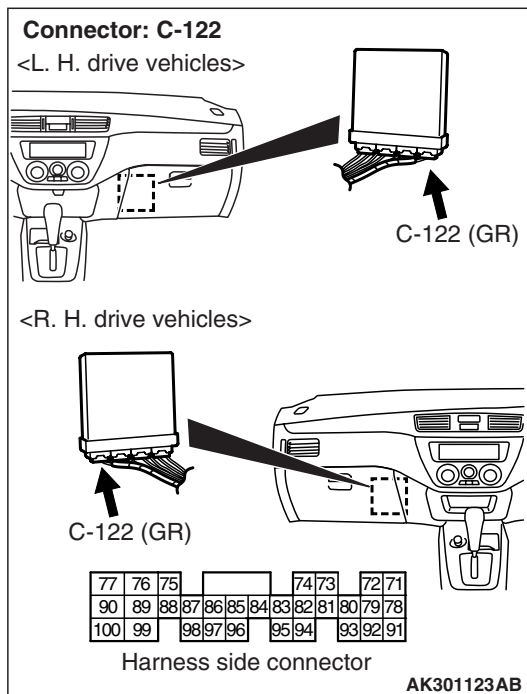
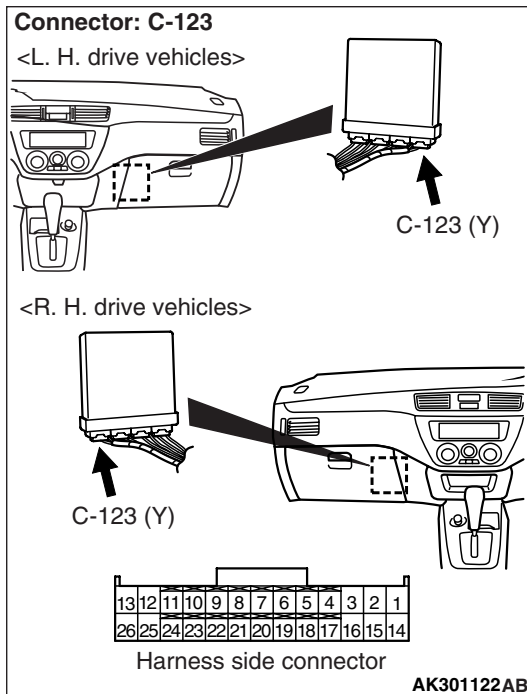

Q: Is the check result normal?

YES : Check and repair harness between B-101 (terminal No. 2) EGR control solenoid valve connector and C-123 (terminal No. 6) engine-ECU <M/T> connector or C-122 (terminal No. 6) engine-A/T-ECU <A/T> connector.

- Check output line for open/short circuit.

NO : Repair or replace.

STEP 8. Connector check: C-123 engine-ECU <M/T> connector or C-122 engine-A/T-ECU <A/T> connector

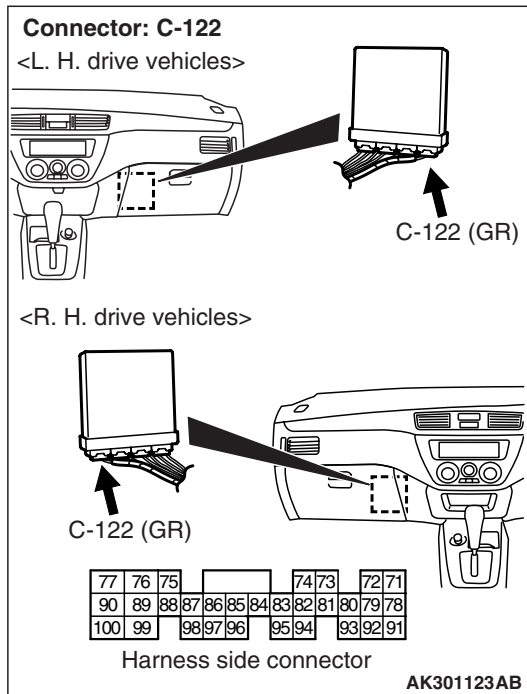
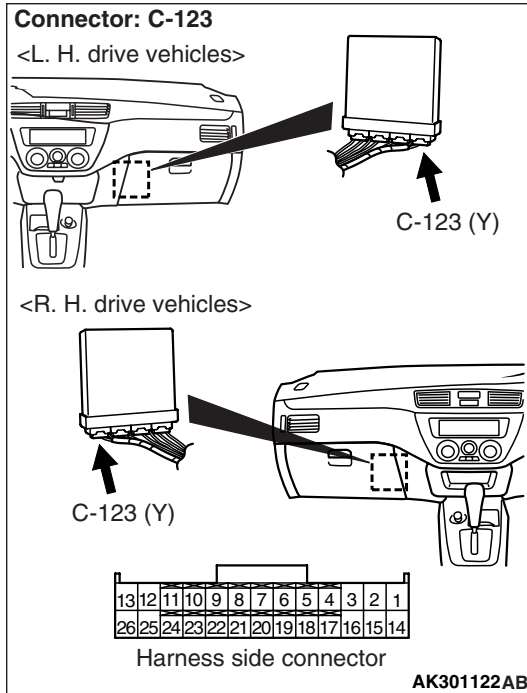

Q: Is the check result normal?

YES : Go to Step 9 .

NO : Repair or replace.

STEP 9. Check harness between B-101 (terminal No. 2) EGR control solenoid valve connector and C-123 (terminal No. 6) engine-ECU <M/T> connector or C-122 (terminal No. 6) engine-A/T-ECU <A/T> connector.

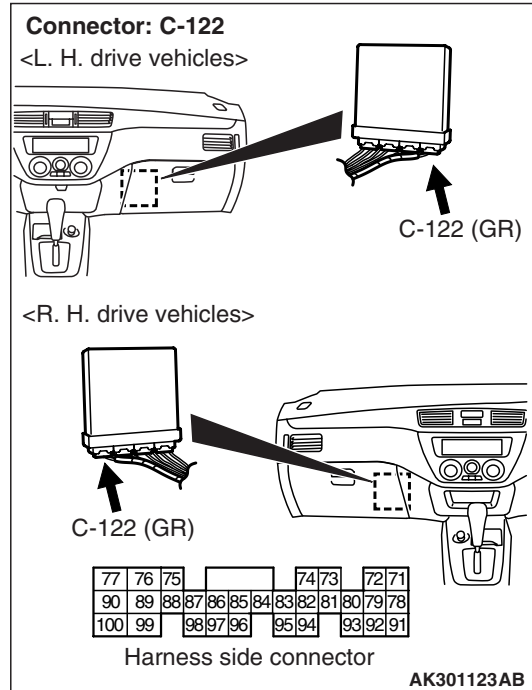
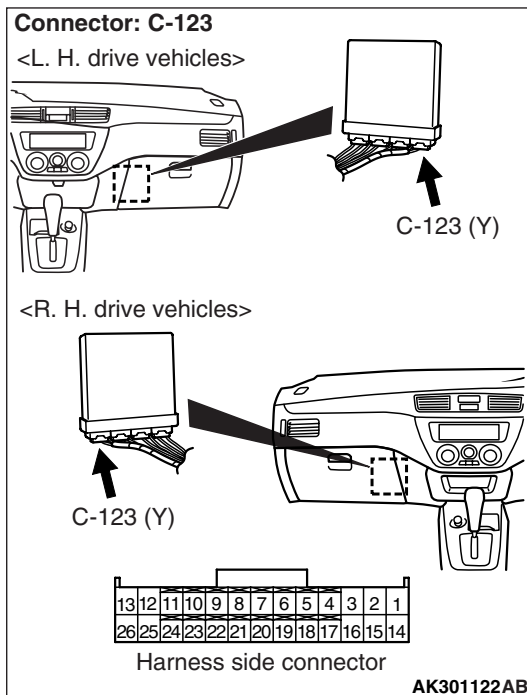
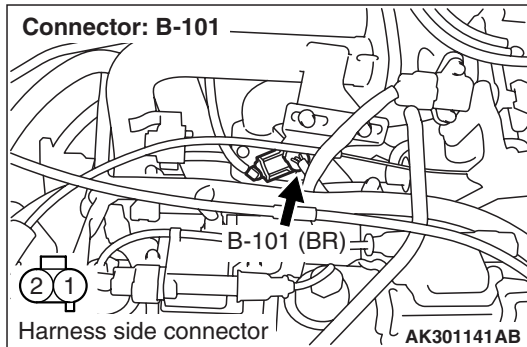

- Check output line for damage.

Q: Is the check result normal?

YES : Go to Step 10 .

NO : Repair.

STEP 10. Check harness between B-101 (terminal No. 1) EGR control solenoid valve connector and B-16X (terminal No. 4) engine control relay connector.

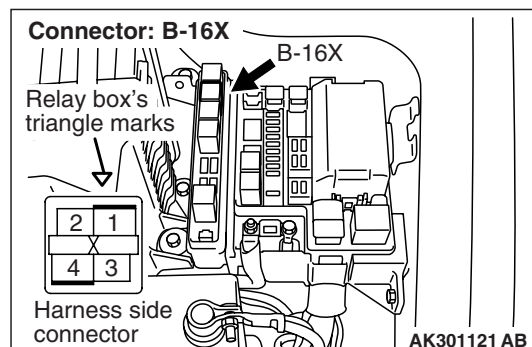
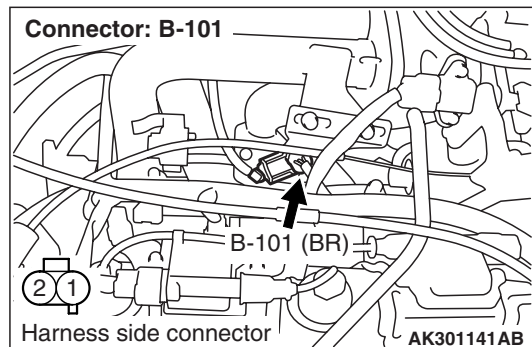

- Check power supply line for damage.

Q: Is the check result normal?

- YES** : Go to Step 11 .
NO : Repair.

STEP 11. M.U.T.-II/III actuator test

- Refer to actuator test reference table [P.13A-383](#).
 - a. Item 10: EGR control solenoid valve

OK: Operating sound can be heard and the valve vibrates.

Q: Is the check result normal?

- YES** : Intermittent malfunction (Refer to GROUP 00 –How to Use Troubleshooting/Inspection Service Points [P.00-5](#)).
NO : Replace engine-ECU <M/T> or engine-A/T-ECU <A/T>.

Code No. P0421: Warm Up Catalyst Malfunction

FUNCTION

- The signal from the oxygen sensor (rear) differs from the oxygen sensor (front). That is because the catalytic converter purifies exhaust gas. When the catalytic converter has deteriorated, the signal from the oxygen sensor (front) becomes similar to the oxygen sensor (rear).
- The engine-ECU <M/T> or engine-A/T-ECU <A/T> compares the output of the front and rear oxygen sensor signals.

TROUBLE JUDGMENT

Check Conditions

- Engine speed: 3,000 r/min or less.
- During the driving.
- During the air-fuel ratio feedback control.

Judgment Criterion

- When the output frequency ratio of the oxygen sensor (rear) vs. the oxygen sensor (front) is 0.8 or more on the average for 12 seconds.

PROBABLE CAUSE

- Catalytic converter deteriorated
- Failed oxygen sensor (front)
- Failed oxygen sensor (rear)
- Failed engine-ECU <M/T>
- Failed engine-A/T-ECU <A/T>

DIAGNOSIS PROCEDURE

STEP 1. Check for leakage of exhaust emission from exhaust manifold.

Q: Is the check result normal?

- YES** : Go to Step 2 .
NO : Repair.

STEP 2. M.U.T.-II/III data list

- Refer to data list reference table [P.13A-376](#).
 - a. Item 11: Oxygen sensor (front)
 - b. Item 59: Oxygen sensor (rear)

Q: Is the check result normal?

- YES** : Go to Step 3 .
NO : Perform the diagnosis code classified check procedure for the sensor that has shown an abnormal data value (Refer to Inspection Chart for diagnosis codes [P.13A-17](#)).

STEP 3. M.U.T.-II/III data list

- Refer to data list reference table [P.13A-376](#).
 - a. Item 11: Oxygen sensor (front)

OK: 0 – 0.4 and 0.6 – 1.0 volt should alternate 15 times or more within 10 seconds (engine speed at 2,000 r/min).

Q: Is the check result normal?

- YES** : Go to Step 4 .
NO : Replace the oxygen sensor (front).

STEP 4. Replace the oxygen sensor (rear).

- After replacing the oxygen sensor (rear), re-check the trouble symptoms.

Q: Is the check result normal?

- YES** : Go to Step 5 .
NO : Check end.

STEP 5. Replace the catalytic converter.

- After replacing the catalytic converter, re-check the trouble symptoms.

Q: Is the check result normal?

- YES** : Replacing engine-ECU <M/T> or engine-A/T-ECU <A/T>.
NO : Check end.

Code No. P0443: Purge Control Solenoid Valve System

Purge control solenoid valve circuit

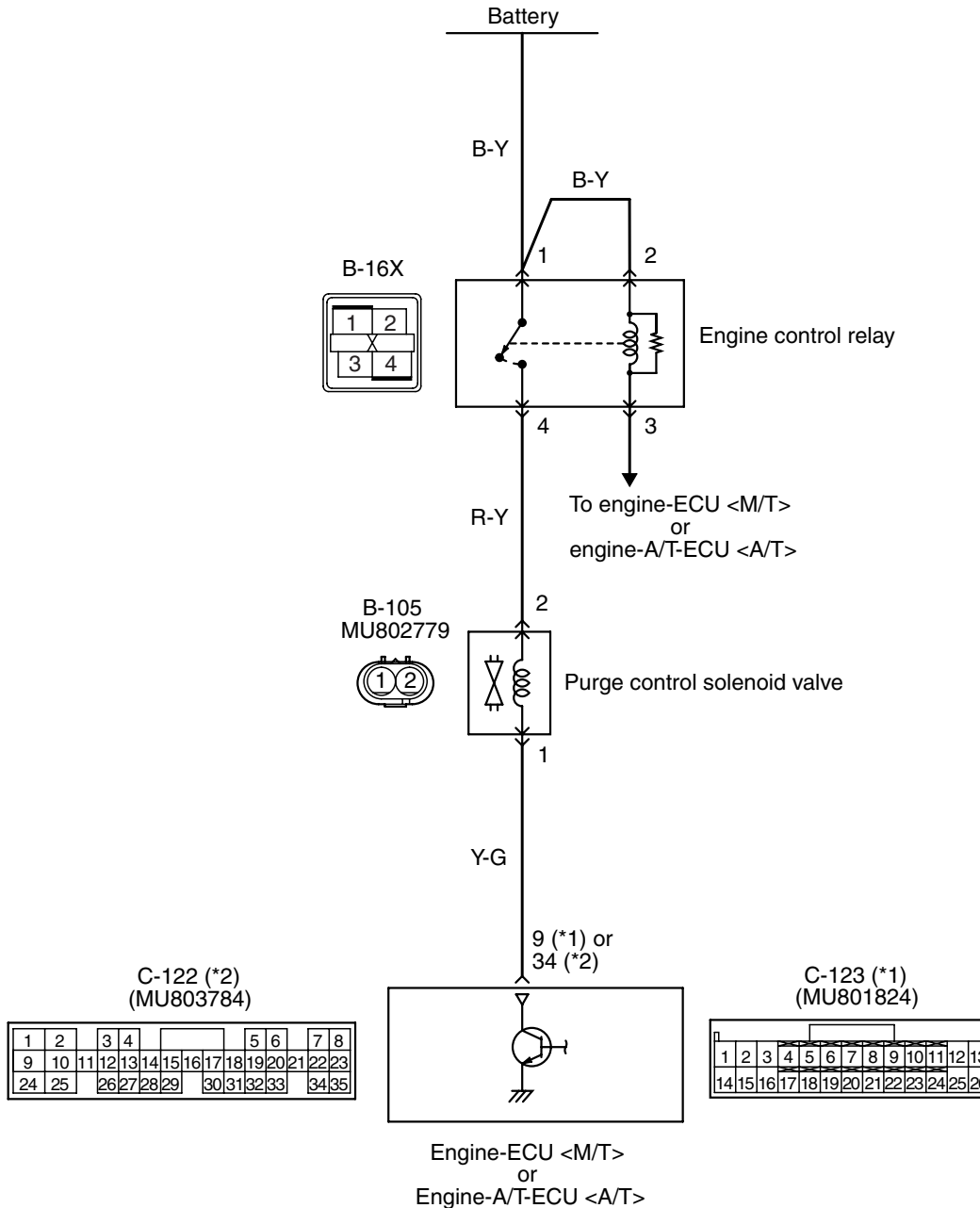

NOTE
*1: M/T
*2: A/T

Wire colour code
B: Black LG: Light green G: Green L: Blue W: White Y: Yellow SB: Sky blue BR: Brown O: Orange GR: Gray
R: Red P: Pink V: Violet

OPERATION

- Power is supplied to the purge control solenoid valve (terminal No. 2) from the engine control relay (terminal No. 4).
- The engine-ECU (terminal No. 9) <M/T> or engine-A/T-ECU (terminal No. 34) <A/T> makes the power transistor in the unit be in "ON" position, and that makes currents go on the purge control solenoid valve (terminal No. 1).

FUNCTION

- In response to a signal from the engine-ECU <M/T> or engine-A/T-ECU <A/T>, the purge control solenoid valve controls the flow rate of the purge air to be introduced into the surge tank.

TROUBLE JUDGMENT**Check Conditions**

- Ignition switch: ON
- The battery voltage is 10 V or more.

Judgment Criterion

- The surge voltage (system voltage + 2 V) of solenoid coil is not detected when the purge control solenoid valve is turned to OFF from ON.
- The battery voltage is 10 V or more.

PROBABLE CAUSE

- Failed purge control solenoid valve
- Open/short circuit in purge control solenoid value circuit or loose connector contact
- Failed engine-ECU <M/T>
- Failed engine-A/T-ECU <A/T>

DIAGNOSIS PROCEDURE**STEP 1. M.U.T.-II/III actuator test**

- Refer to actuator test reference table [P.13A-383](#).
 - Item 08: Purge control solenoid valve
 - OK: Operating sound can be heard and the valve vibrates**

Q: Is the check result normal?

YES : Intermittent malfunction (Refer to GROUP 00 –How to Use Troubleshooting/Inspection Service Points [P.00-5](#)).

NO : Go to Step 2 .

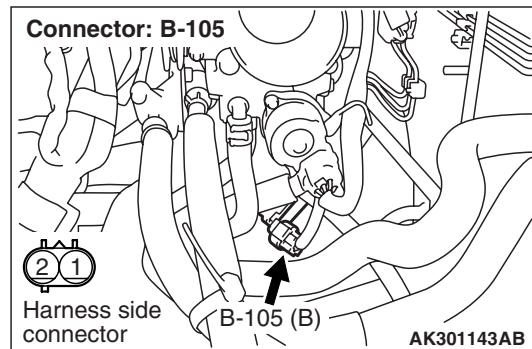
STEP 2. Connector check: B-105 purge control solenoid valve connector**Q: Is the check result normal?**

YES : Go to Step 3 .

NO : Repair or replace.

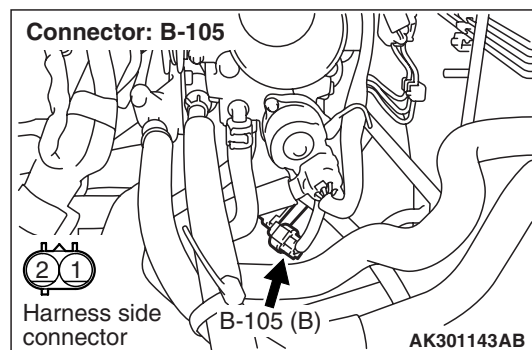
STEP 3. Perform resistance measurement at B-105 purge control solenoid valve connector.

- Disconnect connector, and measure at solenoid valve side.
- Resistance between terminal No. 1 and No. 2.

OK: 30 – 34 Ω (at 20° C)

Q: Is the check result normal?

YES : Go to Step 4 .

NO : Replace purge control solenoid valve.

STEP 4. Perform voltage measurement at B-105 purge control solenoid valve connector.

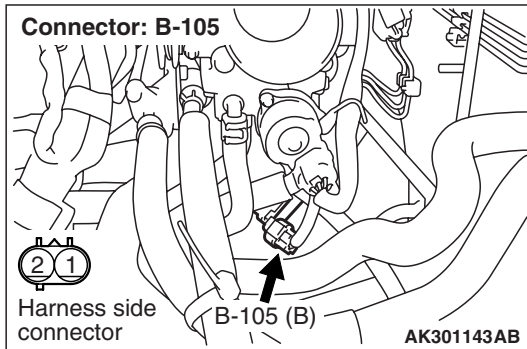

- Disconnect connector, and measure at harness side.
- Ignition switch: ON
- Voltage between terminal No. 2 and earth.

OK: System voltage

Q: Is the check result normal?

YES : Go to Step 6 .

NO : Go to Step 5 .

STEP 5. Connector check: B-16X engine control relay connector

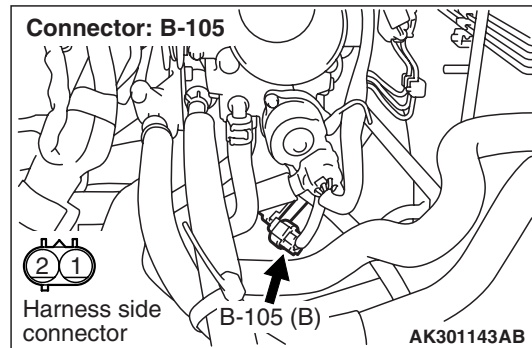
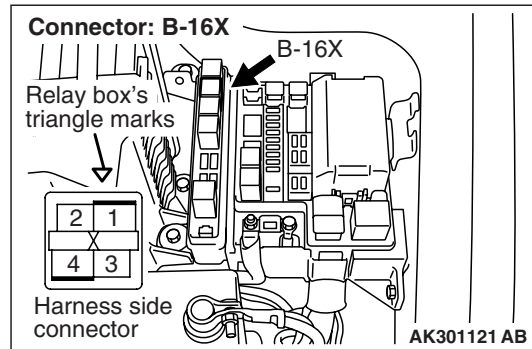

Q: Is the check result normal?

YES : Check and repair harness between B-105 (terminal No. 2) purge control solenoid valve connector and B-16X (terminal No. 4) engine control relay connector.

- Check power supply line for open/short circuit.

NO : Repair or replace.

STEP 6. Perform voltage measurement at C-123 engine-ECU <M/T> connector or C-122 engine-A/T-ECU <A/T> connector.

Q: Is the check result normal?

YES : Go to Step 8 .

NO : Go to Step 7 .

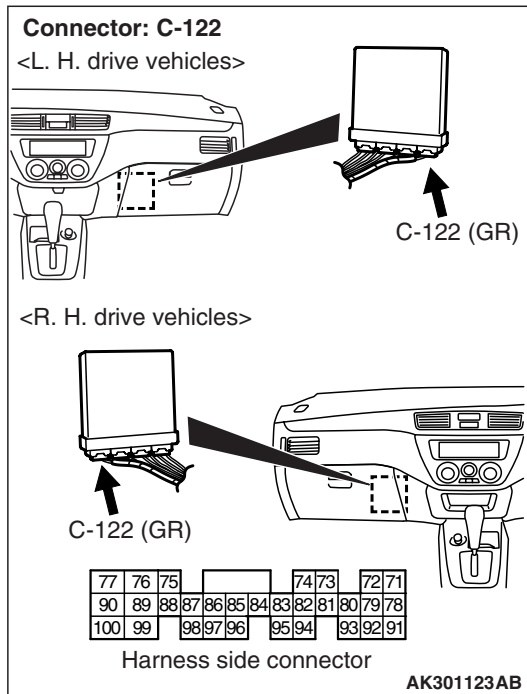
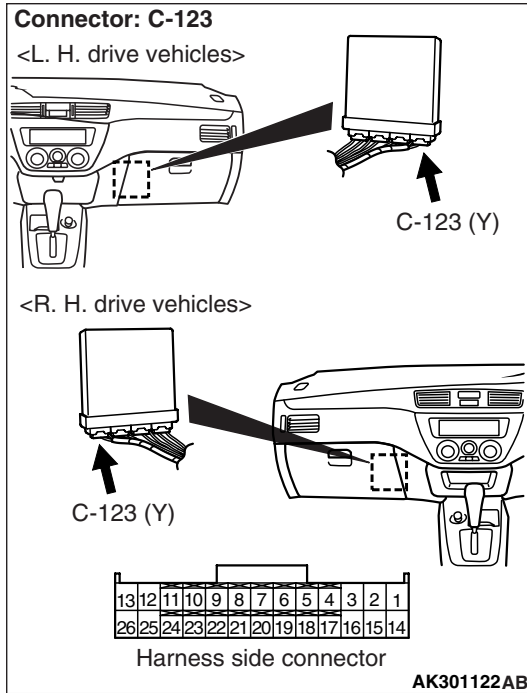

- Disconnect connector, and measure at harness side.
- Ignition switch: ON
- Voltage between terminal No. 9 <M/T> or terminal No. 34 <A/T> and earth.

OK: System voltage

STEP 7. Connector check: C-123 engine-ECU <M/T> connector or C-122 engine-A/T-ECU <A/T> connector

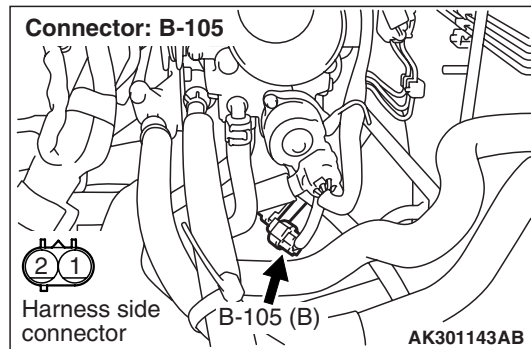
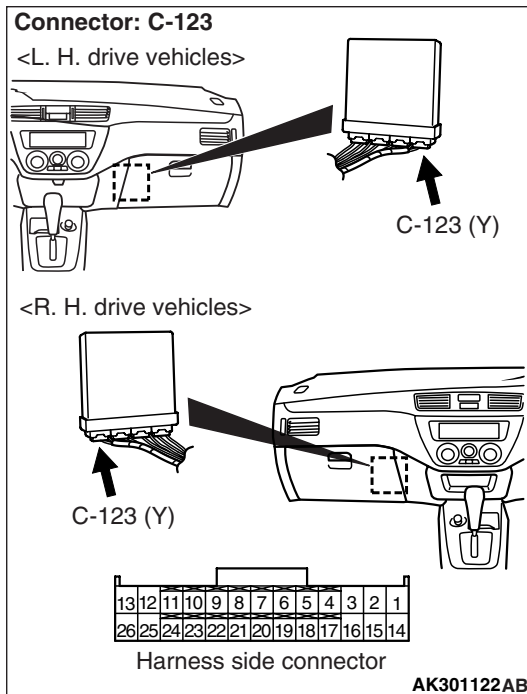

Q: Is the check result normal?

YES : Check and repair harness between B-105 (terminal No. 1) purge control solenoid valve connector and C-123 (terminal No. 9) engine-ECU <M/T> connector or C-122 (terminal No. 34) engine-A/T-ECU <A/T> connector.

- Check output line for open and short circuit.

NO : Repair or replace.

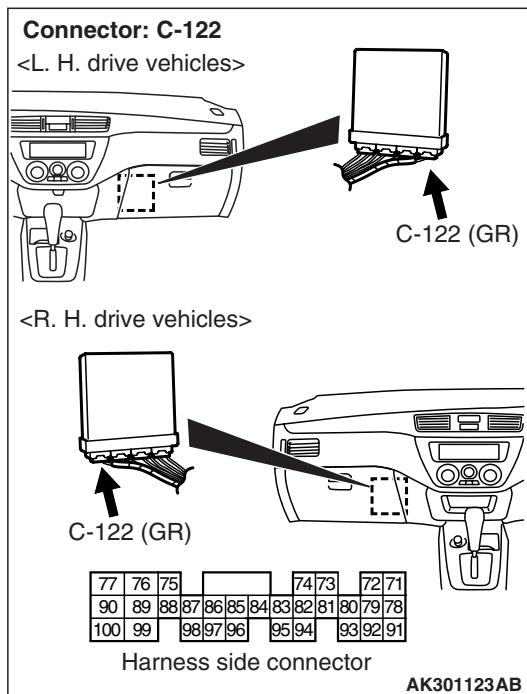

STEP 8. Connector check: C-123 engine-ECU <M/T> connector or C-122 engine-A/T-ECU <A/T> connector

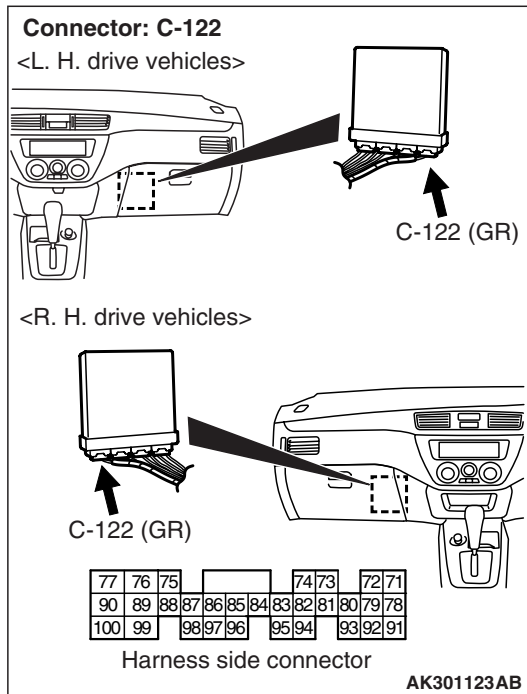
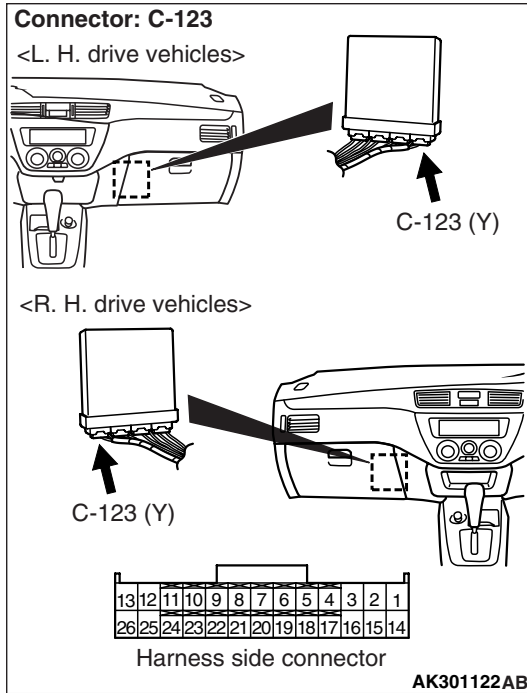

Q: Is the check result normal?

YES : Go to Step 9 .

NO : Repair or replace.

STEP 9. Check harness between B-105 (terminal No. 1) purge control solenoid valve connector and C-123 (terminal No. 9) engine-ECU <M/T> connector or C-122 (terminal No. 34) engine-A/T-ECU <A/T> connector.

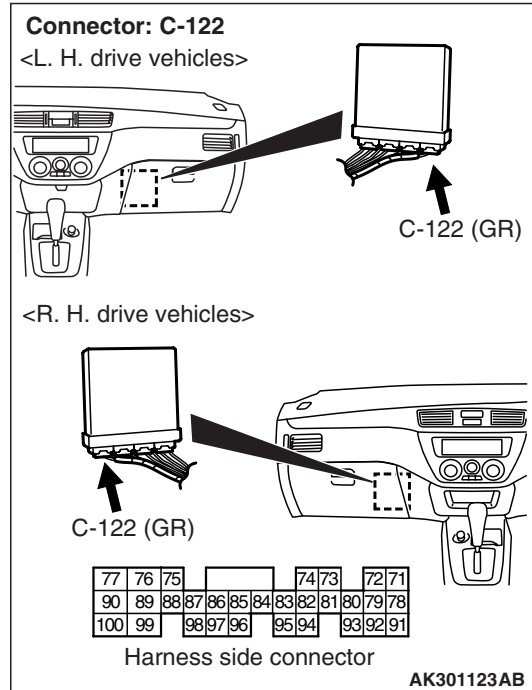
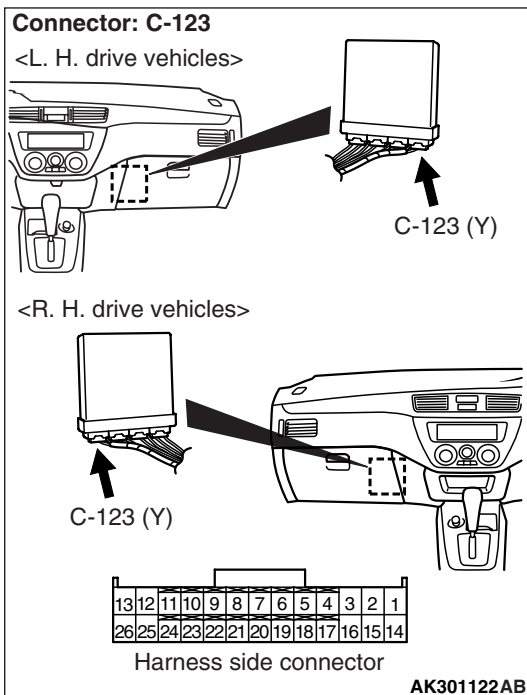
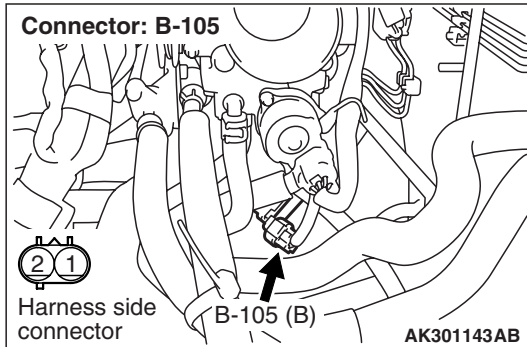

- Check output line for damage.

Q: Is the check result normal?

YES : Go to Step 10 .

NO : Repair.

STEP 10. Check harness between B-105 (terminal No. 2) purge control solenoid valve connector and B-16X (terminal No. 4) engine control relay connector.

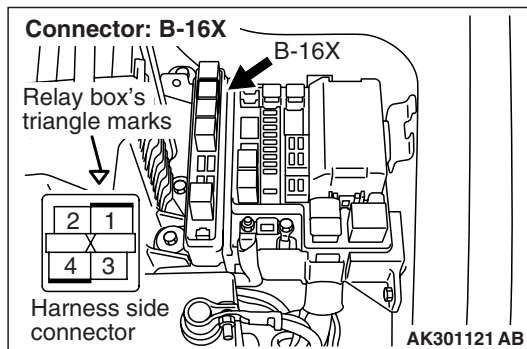
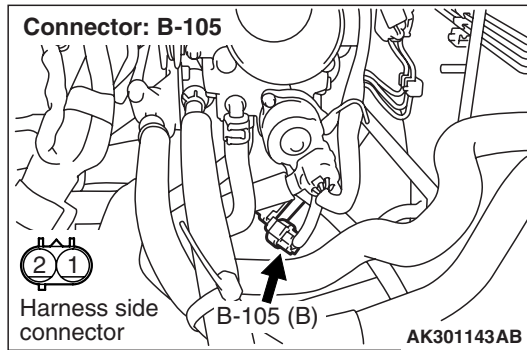

- Check power supply line for damage.

Q: Is the check result normal?

YES : Go to Step 11 .

NO : Repair.

STEP 11. M.U.T.-II/III actuator test

- Refer to actuator test reference table [P.13A-383](#).
 - Item 08: purge control solenoid valve

OK: Operating sound can be heard and the valve vibrates

Q: Is the check result normal?

YES : Intermittent malfunction (Refer to GROUP 00 –How to Use Troubleshooting/Inspection Service Points [P.00-5](#)).

NO : Replace engine-ECU <M/T> or engine-A/T-ECU <A/T>.

Code No. P0500: Vehicle Speed Sensor System <M/T>

Vehicle speed sensor circuit

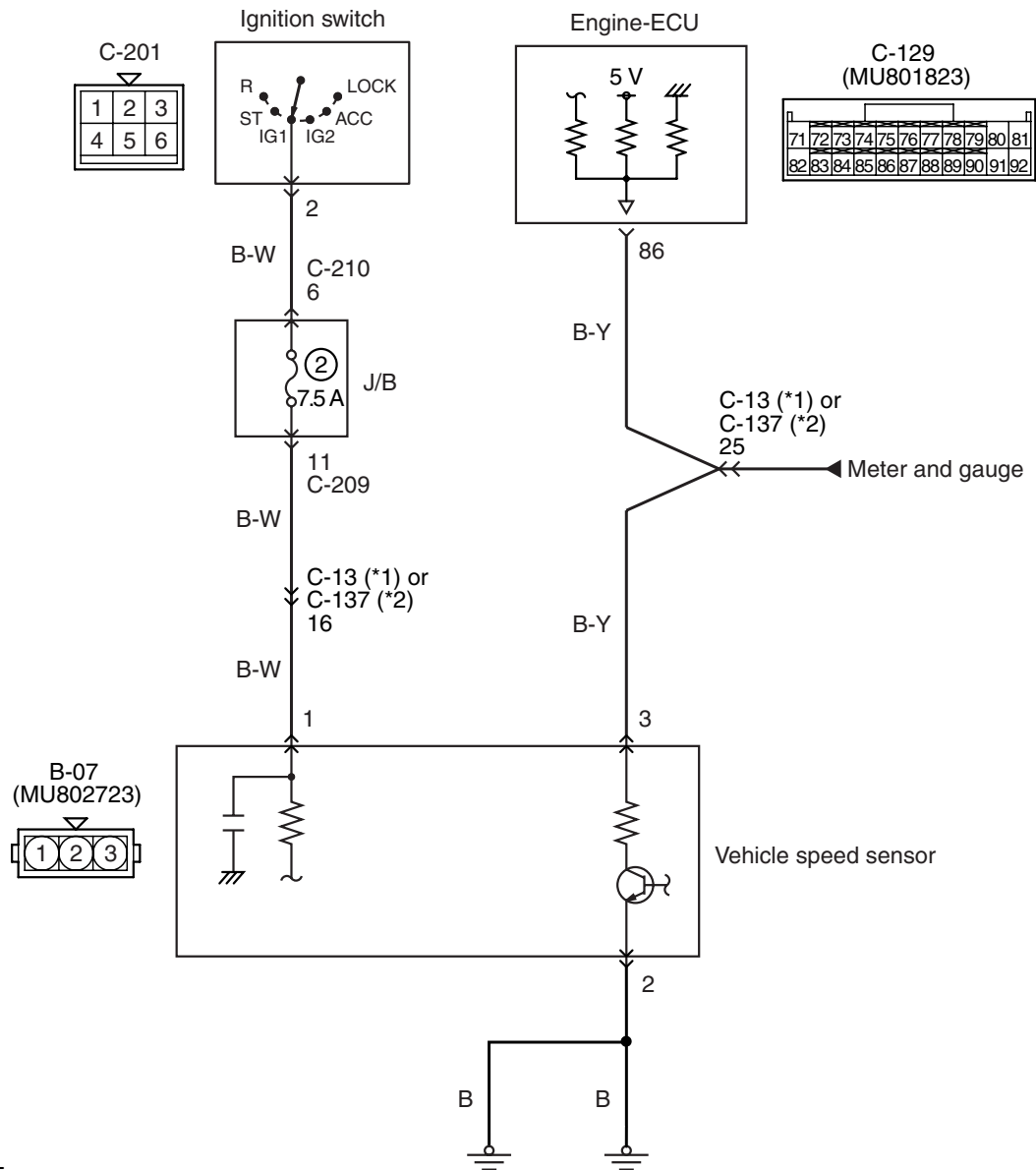

NOTE

- *1: L.H. drive vehicles
- *2: R.H. drive vehicles

Wire colour code

B: Black LG: Light green G: Green L: Blue W: White Y: Yellow SB: Sky blue BR: Brown O: Orange GR: Gray
R: Red P: Pink V: Violet

AK401358AB

OPERATION

- A power voltage of 5 V is applied to the vehicle speed sensor (terminal No. 3) from the engine-ECU (terminal No. 86).

FUNCTION

- The vehicle speed sensor converts the vehicle speed to the voltage, and then input it into the engine-ECU.

TROUBLE JUDGMENT**Check Conditions**

- 2 seconds later after the engine has started up.
- Engine speed: 2,000 r/min or more.

Judgment Criterion

- The sensor output voltage remains unchanged (no pulse signal is inputted) for 2 seconds.

PROBABLE CAUSE

- Failed Vehicle speed sensor
- Open/short circuit in vehicle speed sensor circuit or loose connector contact
- Failed engine-ECU

DIAGNOSIS PROCEDURE**NOTE:**

- *1: L.H. drive vehicles
- *2: R.H. drive vehicles

STEP 1. Check the speedometer**Q: Is the check result normal?****YES :** Go to Step 2 .**NO :** Check the speedometer (Refer to GROUP 54A – Combination Meter Assembly and Vehicle speed sensor –On-vehicle Service P.54A-64).**STEP 2. M.U.T.-II/III data list**

- Refer to data list reference table P.13A-376.
 - Item 24: Vehicle speed sensor

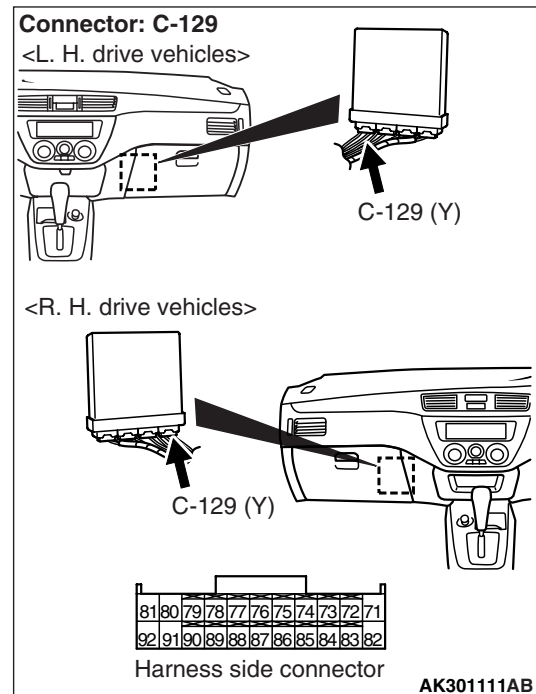
Q: Is the check result normal?**YES :** Go to Step 3 .**NO :** Intermittent malfunction (Refer to GROUP 00 - How to Use Troubleshooting/Inspection Service Points P.00-5).**STEP 3. Check connector: C-129 engine-ECU connector****Q: Is the check result normal?****YES :** Go to Step 4 .**NO :** Repair or replace.

STEP 4. Check harness between C-129 (terminal No. 86) engine-ECU connector and B-07 (terminal No. 3) vehicle speed sensor connector.

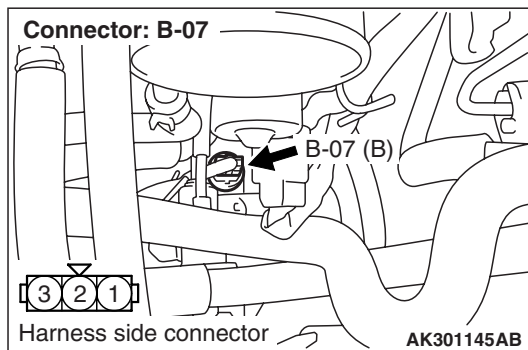
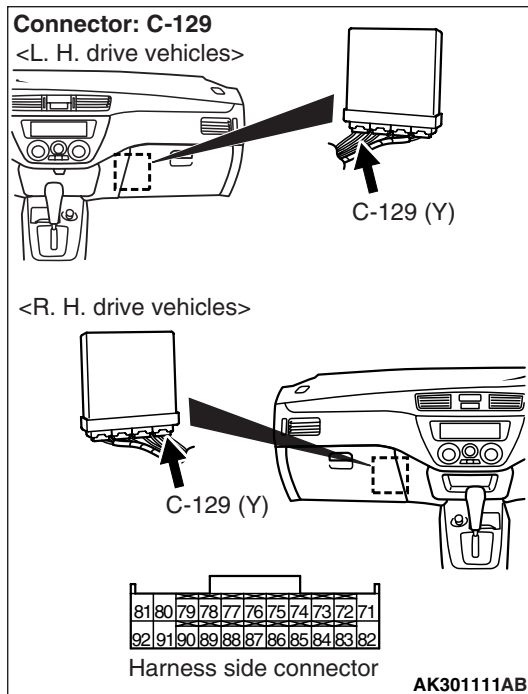

NOTE: Before checking harness, check intermediate connector C-13^{*1} or C-137^{*2}, and repair if necessary.

- Check output line for open circuit and damage.

Q: Is the check result normal?

YES : Go to Step 5 .

NO : Repair.

STEP 5. Check the trouble symptoms.

Q: Does trouble symptom persist?

YES : Replacing engine-ECU <M/T> or engine-A/T-ECU <A/T>.

NO : Intermittent malfunction (Refer to GROUP 00 - How to Use Troubleshooting/Inspection Service Points P.00-5).

Code No. P0505: Idle Speed Control Servo System

Idle speed control servo circuit

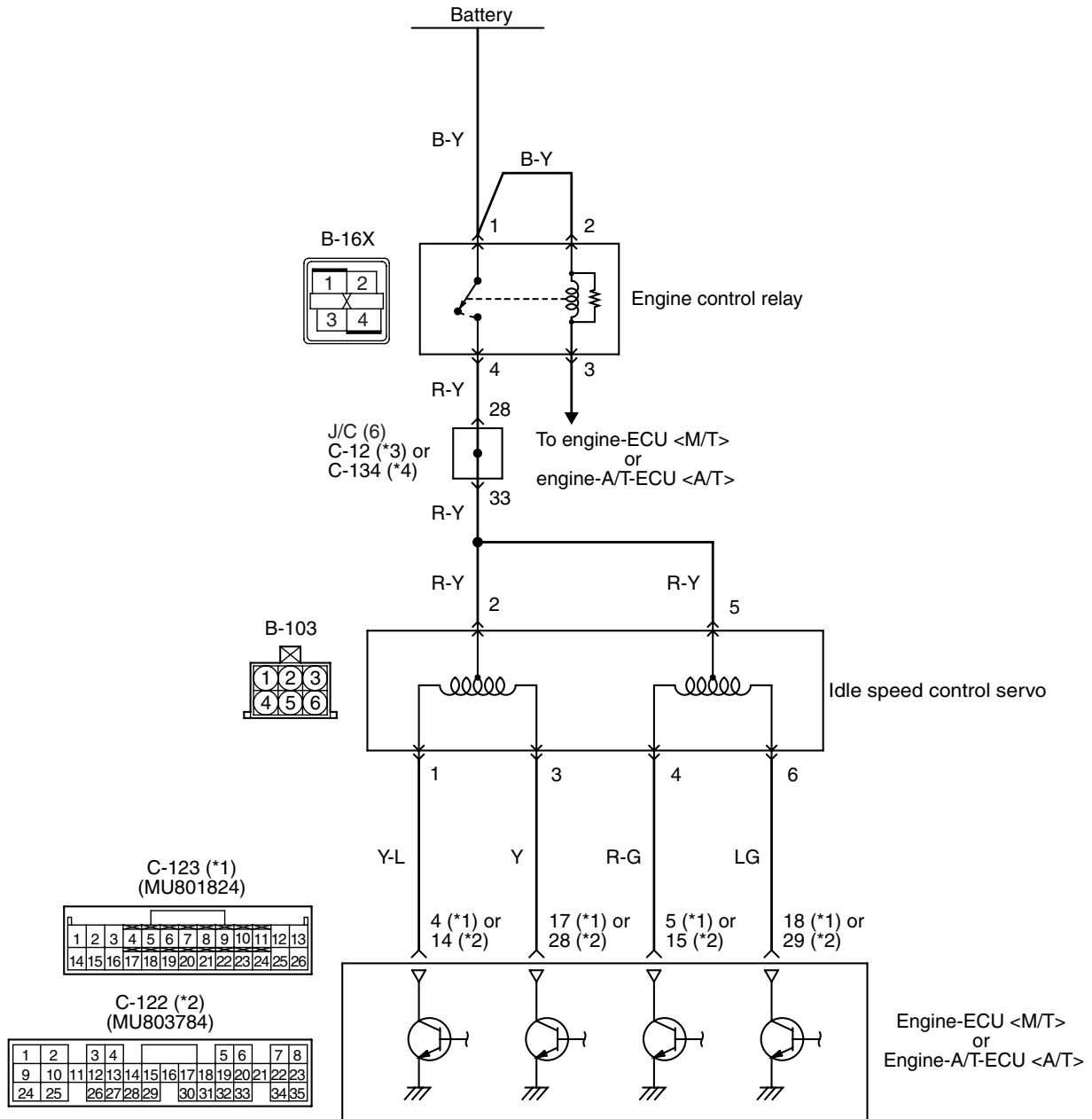

NOTE

- *1: M/T
- *2: A/T
- *3: L.H. drive vehicles
- *4: R.H. drive vehicles

Wire colour code

B: Black LG: Light green G: Green L: Blue W: White Y: Yellow SB: Sky blue BR: Brown O: Orange GR: Gray
 R: Red P: Pink V: Violet

OPERATION

- The power is supplied to the idle speed control servo (terminal No. 2 and No. 5) from the engine control relay (terminal No. 4).
- The engine-ECU (terminal No. 4, No. 5, No. 17 and No. 18) <M/T> or engine-A/T-ECU (terminal No. 14, No. 28, No. 15, No. 29) <A/T> makes power transistor in the unit be in "ON" position in order, and that makes currents go on the idle speed control servo (terminal No. 1, No. 3, No. 4 and No. 6).

FUNCTION

- The idle speed control servo opens and closes the servo valve in response to a signal from the engine-ECU <M/T> or engine-A/T-ECU <A/T> to control the intake air flow rate during idling.

TROUBLE JUDGMENT

Check Conditions

- The vehicle speed has reached 1.5 km/h or more at least once.
- During the closed-loop idle speed control.

Judgment Criterion

- The actual idle speed is higher than the target idle speed by 300 r/min or more for 10 seconds.

Check Conditions

- The vehicle speed has reached 1.5 km/h or more at least once.
- During the closed-loop idle speed control.
- The highest ambient temperature at the last drive is 45 °C or less.
- The engine coolant temperature is 82° C or higher.
- The battery voltage is 10 V or more.
- The intake air temperature is – 10° C or higher.

Judgment Criterion

- The actual idle speed is higher than the target idle speed by 200 r/min or more for 10 seconds.

Check Conditions

- During the closed-loop idle speed control.
- The engine coolant temperature is 82° C or higher.
- The battery voltage is 10 V or more.
- The power steering fluid pressure switch is in OFF position.
- The intake air pipe pressure is 53 kPa or more.
- The intake air temperature is -10° C or higher.

Judgment Criterion

- The actual idle speed is lower than the target idle speed by 100 r/min or more for 10 seconds.

PROBABLE CAUSE

- Failed idle speed control servo
- Open/short circuit in idle speed control servo circuit or loose connector contact
- Failed engine-ECU <M/T>
- Failed engine-A/T-ECU <A/T>

DIAGNOSIS PROCEDURE

NOTE:

*1: L.H. drive vehicles

*2: R.H. drive vehicles

STEP 1. M.U.T.-II/III data list

- Refer to data list reference table [P.13A-376](#).
 - Item 45: Idle speed control position

Q: Is the check result normal?

YES : Intermittent malfunction (Refer to GROUP 00 –How to Use Troubleshooting/Inspection Service Points [P.00-5](#)).

NO : Go to Step 2 .

STEP 2. Connector check: B-103 idle speed control servo connector

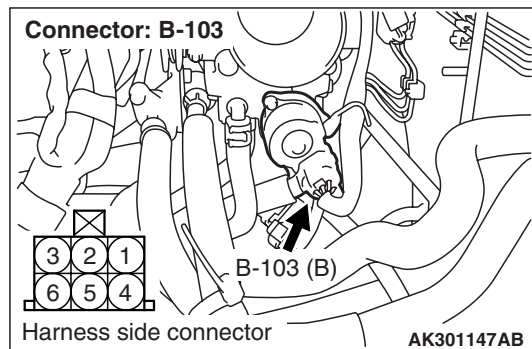

Q: Is the check result normal?

YES : Go to Step 3 .

NO : Repair or replace.

STEP 3. Check idle speed control servo itself.

- Check idle speed control servo itself (Refer to [P.13A-408](#)).

Q: Is the check result normal?

YES : Go to Step 4 .

NO : Replace idle speed control servo.

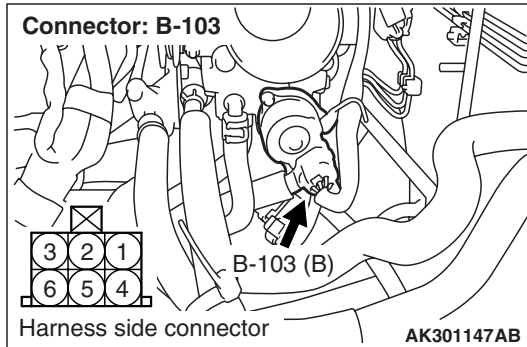
STEP 4. Perform voltage measurement at B-103 idle speed control servo connector.

- Disconnect connector, and measure at harness side.
- Ignition switch: ON
- Voltage between terminal No. 2 and earth, also between terminal No. 5 and earth.

OK: System voltage

Q: Is the check result normal?

YES : Go to Step 6 .

NO : Go to Step 5 .

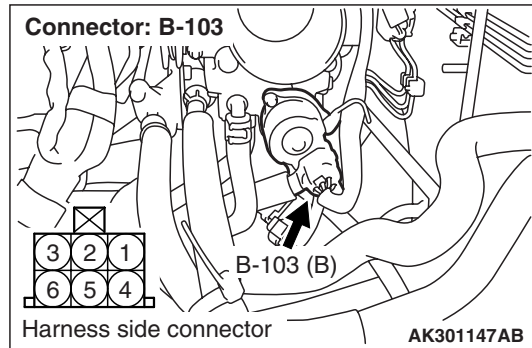
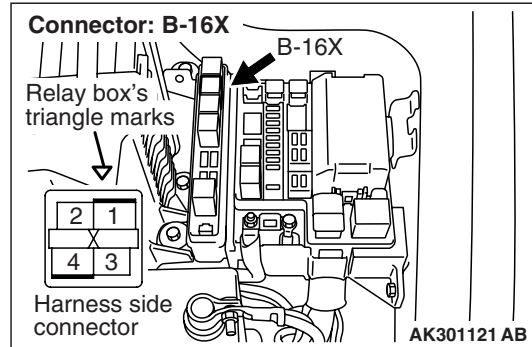
STEP 5. Check connector: B-16X engine control relay connector

Q: Is the check result normal?

YES : Check intermediate connector C-12^{*1} or C-134^{*2}, and repair if necessary. If intermediate connector is normal, check and repair harness between B-103 (terminal No. 2 or No. 5) idle speed control servo connector and B-16X (terminal No. 4) engine control relay connector.

- Check power supply line for open/short circuit.

NO : Repair or replace.

STEP 6. Perform voltage measurement at C-123 engine-ECU <M/T> connector or C-122 engine-A/T-ECU <A/T> connector.

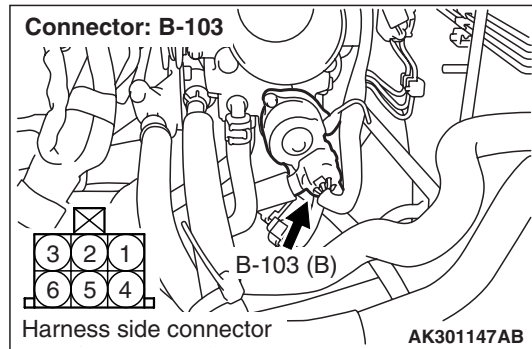
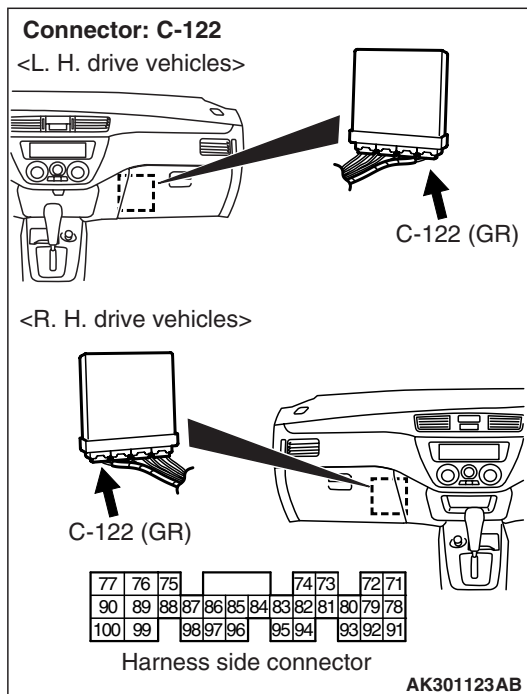
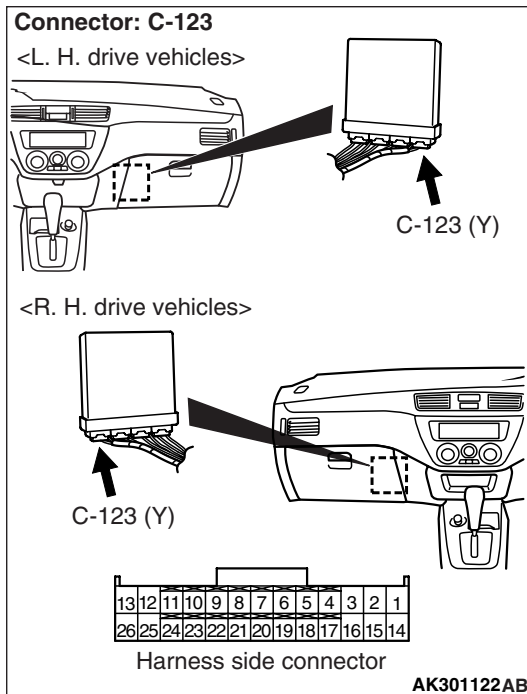

- Disconnect connector, and measure at harness side.
- Ignition switch: ON
- Voltage between terminal No. 4 <M/T> or terminal No. 14 <A/T> and earth, between terminal No. 5 <M/T> or terminal No. 15 <A/T> and earth, between terminal No. 17 <M/T> or terminal No. 28 <A/T> and earth, also voltage between terminal No. 18 <M/T> or terminal No. 29 <A/T> and earth.

OK: System voltage

Q: Is the check result normal?

YES : Go to Step 7 .

NO : Check and repair harness between B-103 idle speed control servo and C-123 engine-ECU <M/T> or C-122 engine-A/T-ECU <A/T>.

1. Harness between idle speed control servo terminal No. 1 and engine-ECU <M/T> connector terminal No. 4 or engine-A/T-ECU <A/T> connector terminal No. 14
2. Harness between idle speed control servo terminal No. 3 and engine-ECU <M/T> connector terminal No. 17 or engine-A/T-ECU <A/T> connector terminal No. 28
3. Harness between idle speed control servo terminal No. 4 and engine-ECU <M/T> connector terminal No. 5 or engine-A/T-ECU <A/T> connector terminal No. 15
4. Harness between idle speed control servo terminal No. 6 and engine-ECU <M/T> connector terminal No. 18 or engine-A/T-ECU <A/T> connector terminal No. 29
 - Check power supply line for open/short circuit.

STEP 7. Connector check: C-123 engine-ECU <M/T> connector or C-122 engine-A/T-ECU <A/T> connector

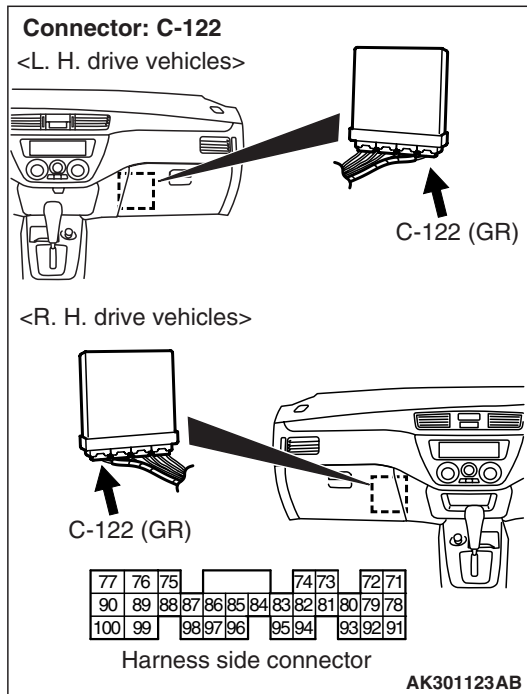
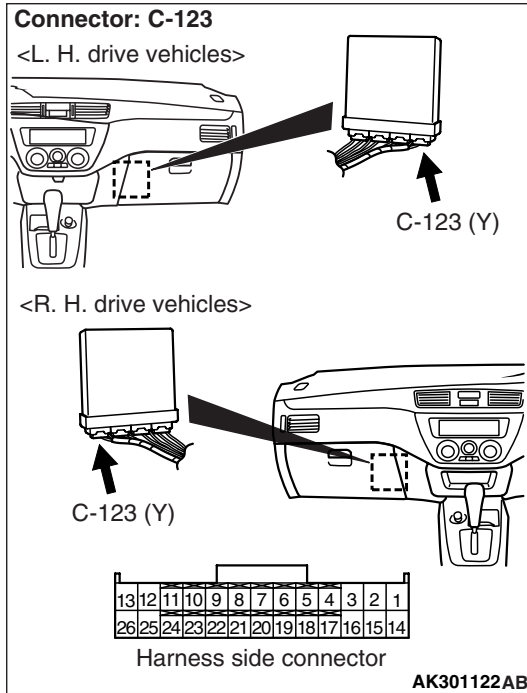

Q: Is the check result normal?

YES : Go to Step 8 .

NO : Repair or replace.

STEP 8. Check harness between B-103 idle speed control servo and C-123 engine-ECU <M/T> connector or C-122 engine-A/T-ECU <A/T>.

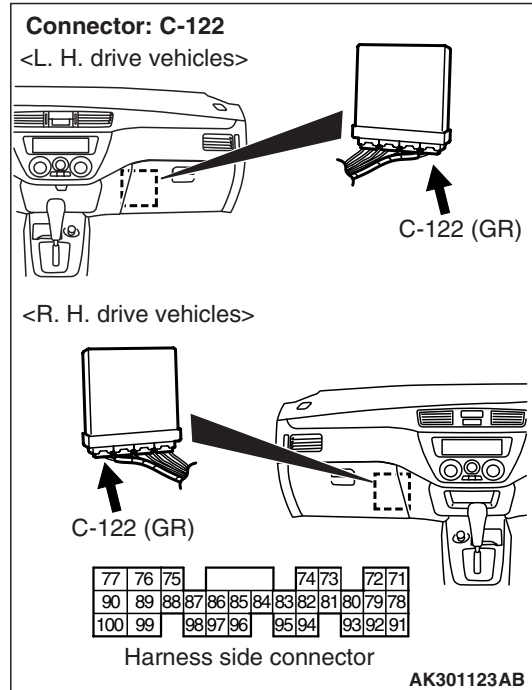
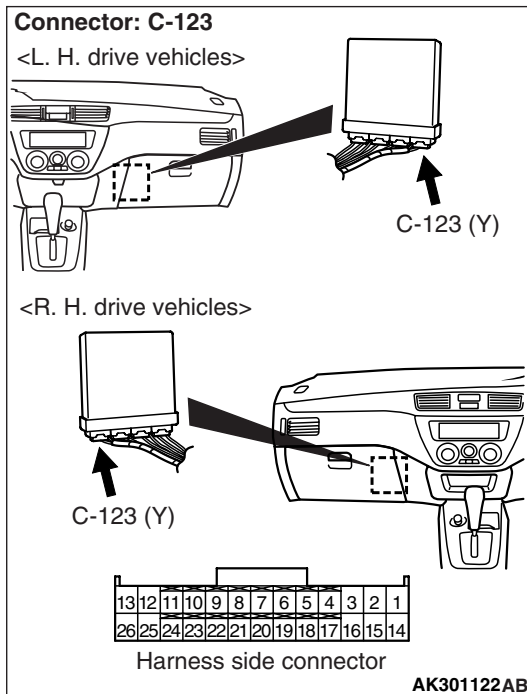
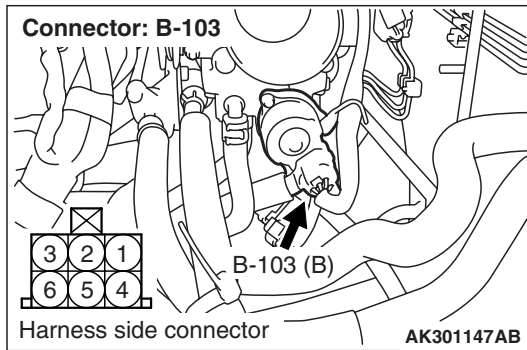

1. Harness between idle speed control servo terminal No. 1 and engine-ECU <M/T> connector terminal No. 4 or engine-A/T-ECU <A/T> connector terminal No. 14
 2. Harness between idle speed control servo terminal No. 3 and engine-ECU <M/T> connector terminal No. 17 or engine-A/T-ECU <A/T> connector terminal No. 28
 3. Harness between idle speed control servo terminal No. 4 and engine-ECU <M/T> connector terminal No. 5 or engine-A/T-ECU <A/T> connector terminal No. 15
 4. Harness between idle speed control servo terminal No. 6 and engine-ECU <M/T> connector terminal No. 18 or engine-A/T-ECU <A/T> connector terminal No. 29
- Check output line for damage.

Q: Is the check result normal?

YES : Go to Step 9 .

NO : Repair.

STEP 9. Check harness between B-103 (terminal No. 2 or No. 5) idle speed control servo connector and B-16X (terminal No. 4) engine control relay connector.

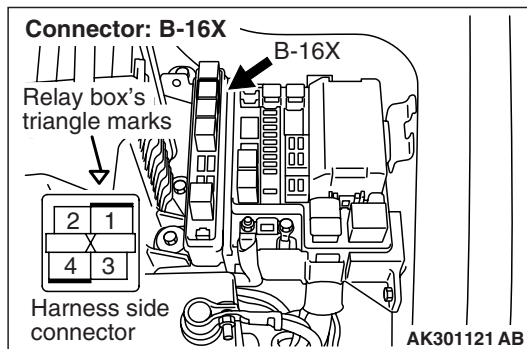
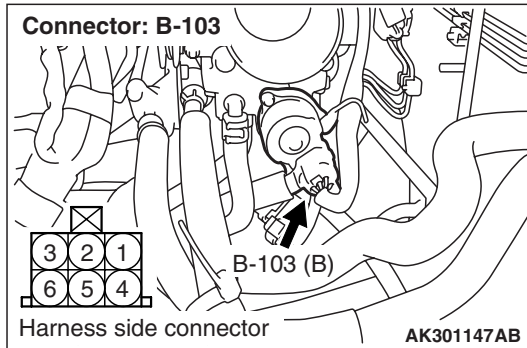

NOTE: Before checking harness, check intermediate connector C-12*¹ or C-134*², and repair if necessary.

- Check power supply line for damage.

Q: Is the check result normal?

YES : Go to Step 10 .

NO : Repair.

STEP 10. M.U.T.-II/III data list

- Refer to data list reference table [P.13A-376](#).
 - a. Item 45: Idle speed control position

Q: Is the check result normal?

YES : Intermittent malfunction (Refer to GROUP 00 –How to Use Troubleshooting/Inspection Service Points [P.00-5](#)).

NO : Replace engine-ECU <M/T> or engine-A/T-ECU <A/T>.

Code No. P0513: Immobilizer System

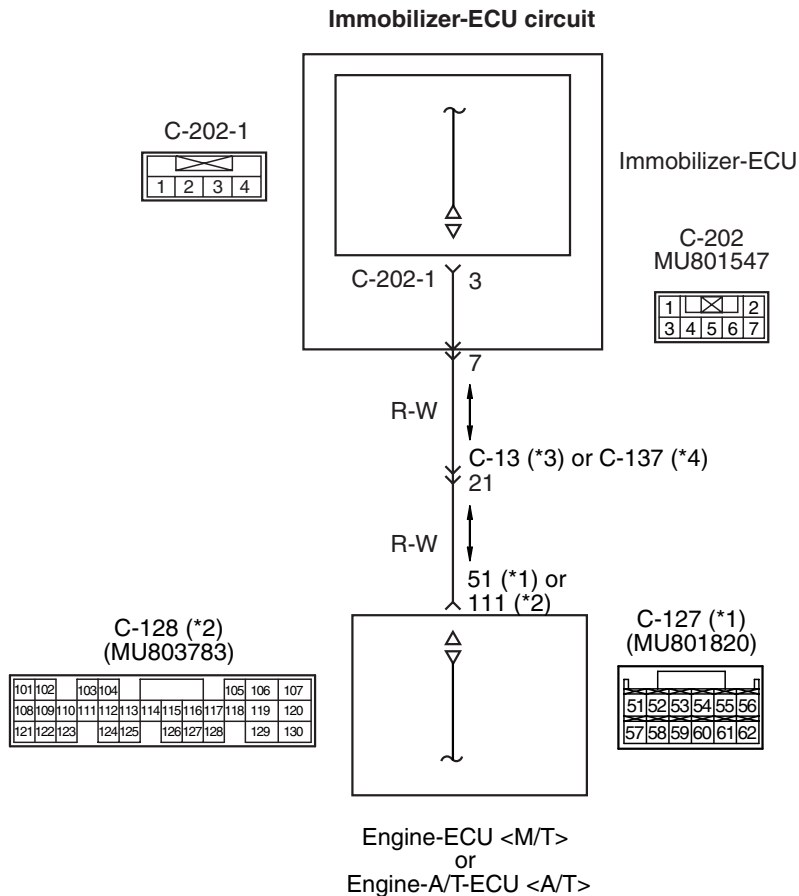

NOTE

- *1: M/T
- *2: A/T
- *3: L.H. drive vehicles
- *4: R.H. drive vehicles

Wire colour code

B: Black LG: Light green G: Green L: Blue W: White Y: Yellow SB: Sky blue BR: Brown O: Orange GR: Gray
R: Red P: Pink V: Violet

AK301148AC

OPERATION

- The signals are sent and received between engine-ECU (terminal No. 51) <M/T> or engine-A/T-ECU (terminal No. 111) <A/T> and immobilizer-ECU (terminal No. 7).

FUNCTION

- Engine-ECU <M/T> or engine-A/T-ECU <A/T> sends or receives the control signals to or from immobilizer-ECU to certify the ignition key.

NOTE:

- If the registered ignition keys are close each other when starting the engine, radio interference may cause this code to be displayed.
- This code may be displayed when registering the key encrypted code.

TROUBLE JUDGMENT

Check Condition

- Ignition switch: ON

Judgment Criterion

- Improper communication problems between the engine-ECU <M/T> or engine-A/T-ECU <A/T> and the immobilizer-ECU is detected.

PROBABLE CAUSE

- Open/short circuit in immobilizer system circuit or loose connector contact
- Failed immobilizer-ECU
- Failed engine-ECU <M/T>
- Failed engine-A/T-ECU <A/T>

DIAGNOSIS PROCEDURE

NOTE:

- *1: L.H. drive vehicles
- *2: R.H. drive vehicles

STEP 1. Connector check: C-202 immobilizer-ECU connector and C-127 engine-ECU <M/T> connector or C-128 engine-A/T-ECU <A/T> connector

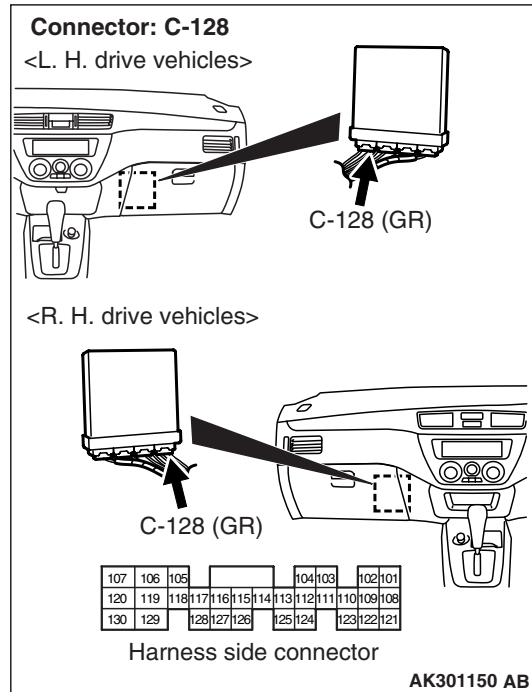
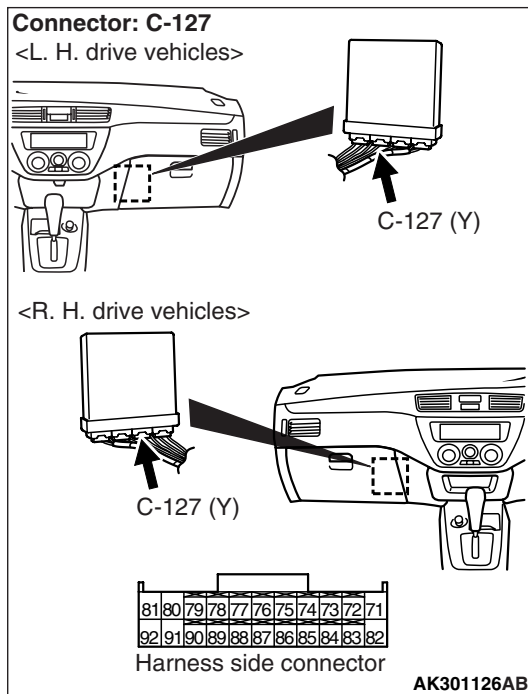
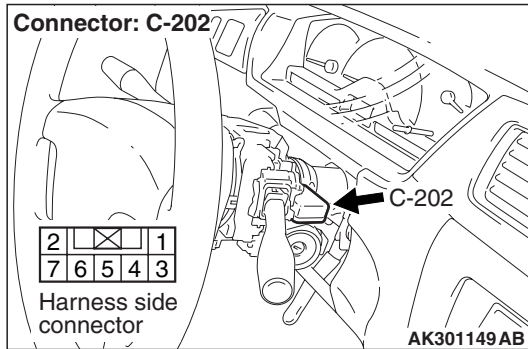

Q: Is the check result normal?
YES : Go to Step 2 .
NO : Repair or replace.

STEP 2. Check harness between C-202 (terminal No. 7) immobilizer-ECU connector and C-127 (terminal No. 51) engine-ECU <M/T> connector or C-128 (terminal No. 111) engine-A/T-ECU <A/T> connector.

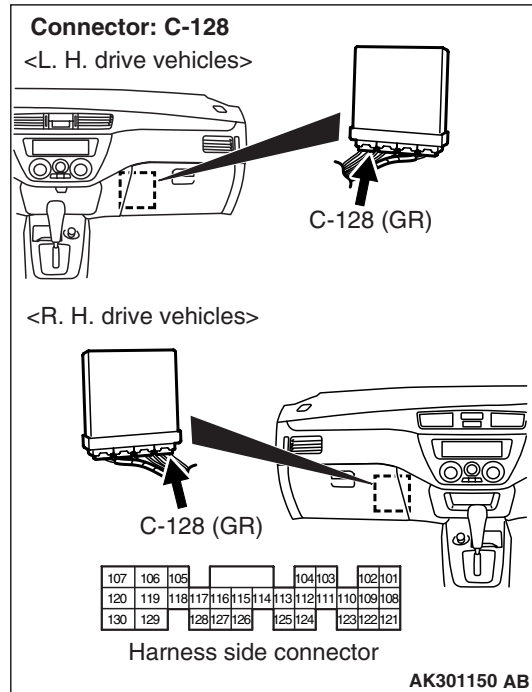
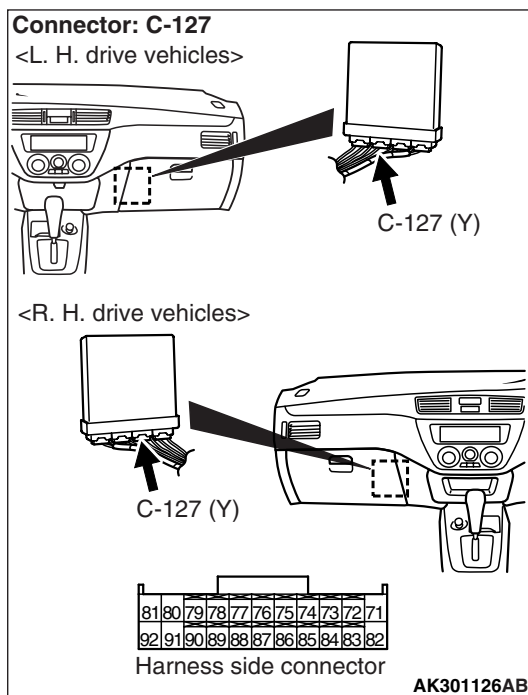
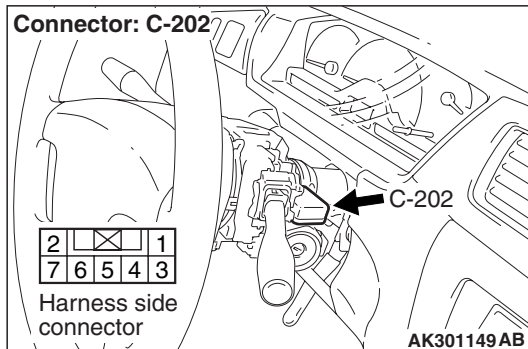

NOTE: Before checking harness, check intermediate connector C-13*¹ or C-137*², and repair if necessary.

- Check output line for open/short circuit and damage.

Q: Is the check result normal?

YES : Go to Step 3 .

NO : Repair.

STEP 3. Check the trouble symptoms.

Q: Does trouble symptom persist?

YES : Go to Step 4 .

NO : Intermittent malfunction (Refer to GROUP 00 –How to Use Troubleshooting/Inspection Service Points P.00-5).

STEP 4. After replacing the immobilizer-ECU, re-check the trouble symptoms.

Q: Does trouble symptom persist?

YES : Replace engine-ECU <M/T> or engine-A/T-ECU <A/T>.

NO : Check end.

Code No. P0551: Power Steering Fluid Pressure Switch System

Power steering fluid pressure switch circuit

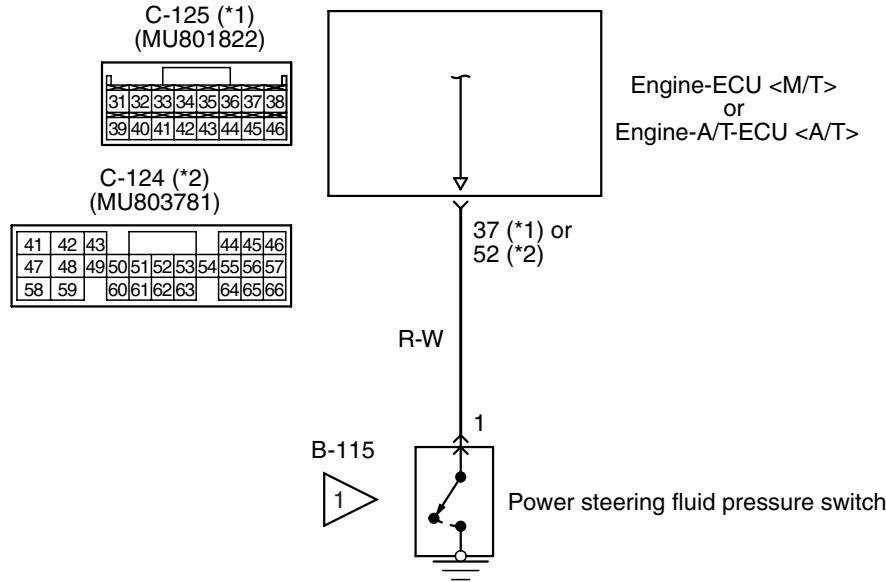

NOTE
*1: M/T
*2: A/T

Wire colour code
B: Black LG: Light green G: Green L: Blue W: White Y: Yellow SB: Sky blue BR: Brown O: Orange GR: Grey
R: Red P: Pink V: Violet

AK301151AC

CONDITION

- The battery voltage is applied to the power steering fluid pressure switch (terminal No. 1) from the engine-ECU (terminal No. 37) <M/T> or engine-A/T-ECU (terminal No. 52) <A/T>.

FUNCTION

- It is detected whether a load is applied on the power steering fluid pump by steering or not, and the signal is inputted to the engine-ECU <M/T> or engine-A/T-ECU <A/T>. When the power steering fluid pressure switch "ON" signal (a large load on the power steering fluid pump) is inputted, the engine-ECU <M/T> or engine-A/T-ECU <A/T> provides the idle-up control.

TROUBLE JUDGMENT

Check Conditions

- The intake air temperature is -10° C or higher.

- The engine coolant temperature is 30° C or higher.
- Repeat, 10 times or more, the *1 running and stop also *2 running.
*1 running: engine speed of 2,500 r/min or more (Vehicle speed of 50 km/h or more).
*2 running: Vehicle speed of 1.5 km/h or less.

Judgment Criteria

- The power steering fluid pressure switch remains in ON position.

PROBABLE CAUSE

- Failed power steering fluid pressure switch
- Open/short circuit in power steering fluid pressure switch circuit or loose connector contact
- Failed engine-ECU <M/T>
- Failed engine-A/T-ECU <A/T>

DIAGNOSIS PROCEDURE

STEP 1. Connector check: B-115 power steering fluid pressure switch connector

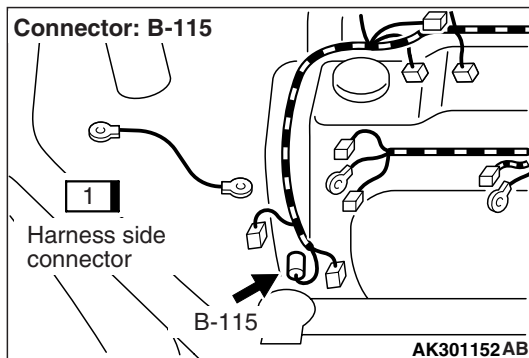

Q: Is the check result normal?
YES : Go to Step 2 .
NO : Repair or replace.

STEP 2. Perform voltage measurement at B-115 power steering fluid pressure switch connector.

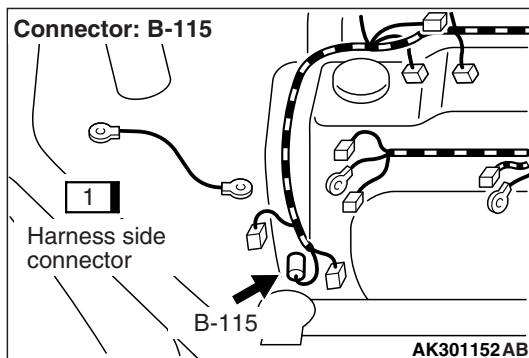

- Disconnect connector, and measure at harness side.
- Ignition switch: ON
- Voltage between terminal No. 1 and earth.

OK: System voltage

Q: Is the check result normal?
YES : Go to Step 8 .
NO : Go to Step 3 .

STEP 3. Perform voltage measurement at C-125 engine-ECU <M/T> connector or C-124 engine-A/T-ECU <A/T> connector.

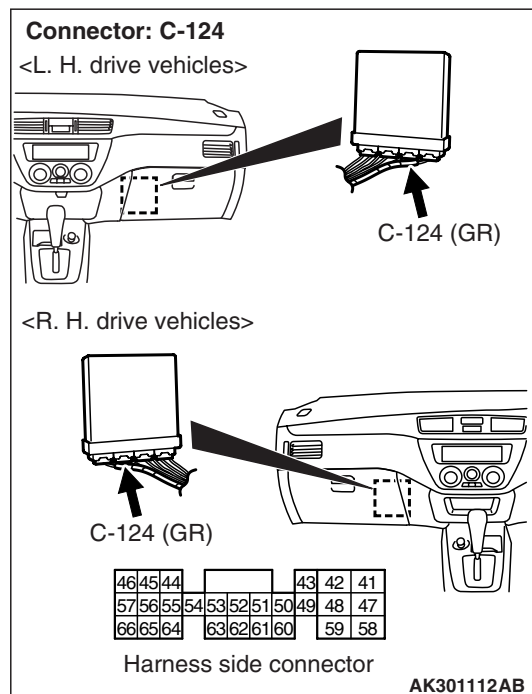
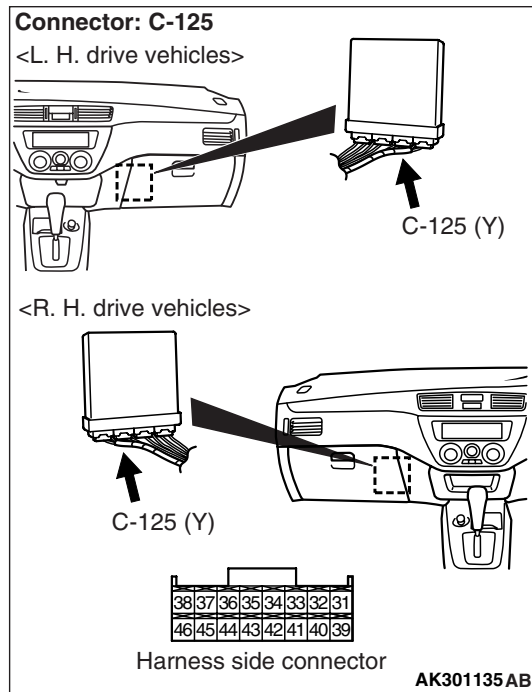

- Measure engine-ECU <M/T> or engine-A/T-ECU <A/T> terminal voltage.
- Ignition switch: ON
- Voltage between terminal No. 37 <M/T> or terminal No. 52 <A/T> and earth.

OK: System voltage

Q: Is the check result normal?
YES : Go to Step 4 .
NO : Go to Step 5 .

STEP 4. Connector check: C-125 engine-ECU <M/T> connector or C-124 engine-A/T-ECU <A/T> connector

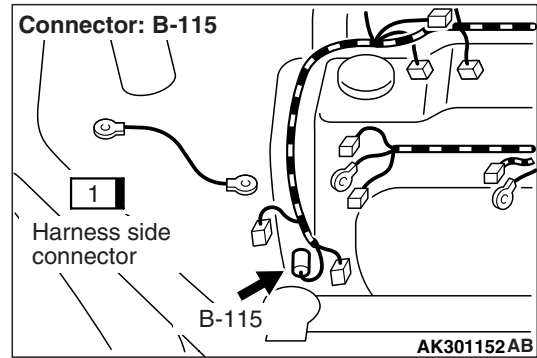
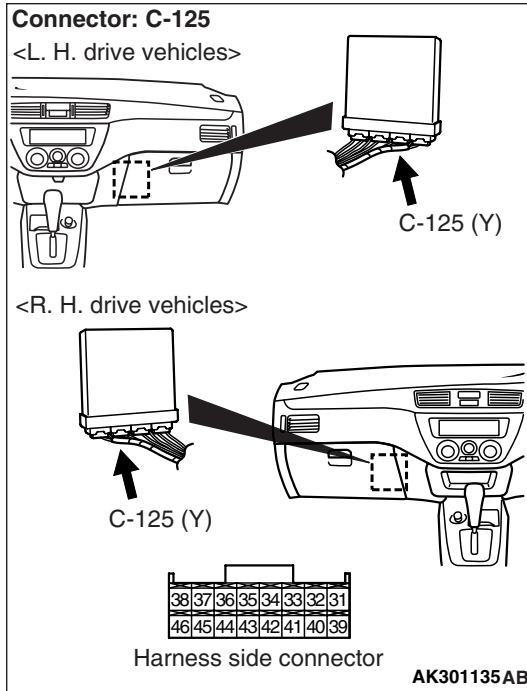

Q: Is the check result normal?

YES : Check and repair harness between B-115 (terminal No. 1) power steering fluid pressure switch connector and C-125 (terminal No. 37) engine-ECU <M/T> connector or C-124 (terminal No. 52) engine-A/T-ECU <A/T> connector.

- Check output line for open circuit.

NO : Repair or replace.

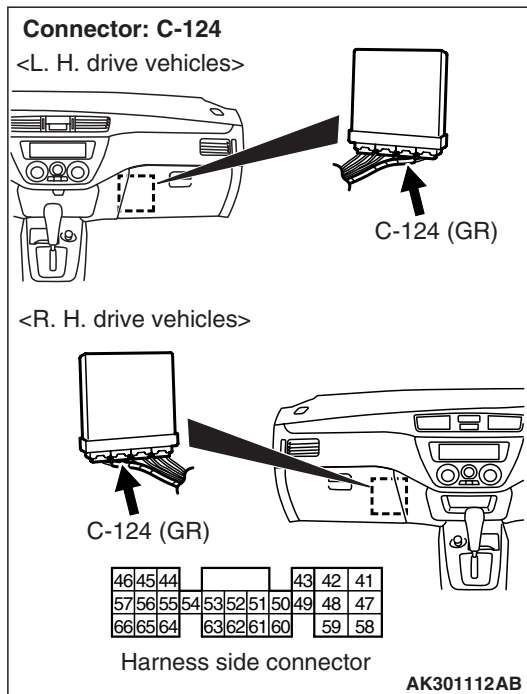

**STEP 5. Connector check: C-125 engine-ECU
<M/T> connector or C-124 engine-A/T-ECU <A/T>
connector**

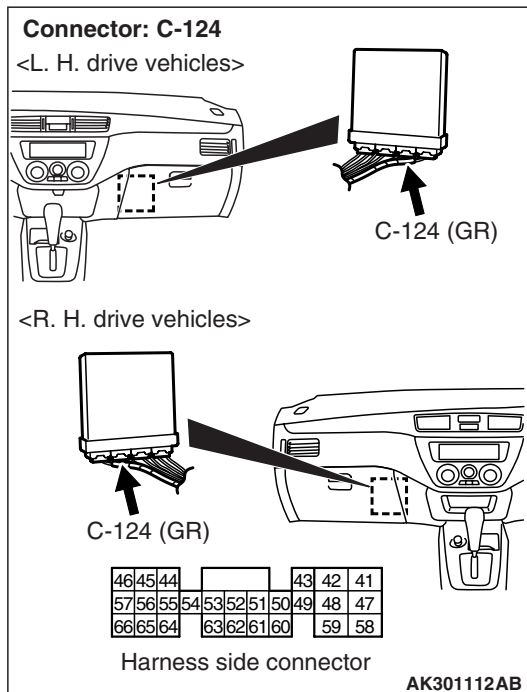
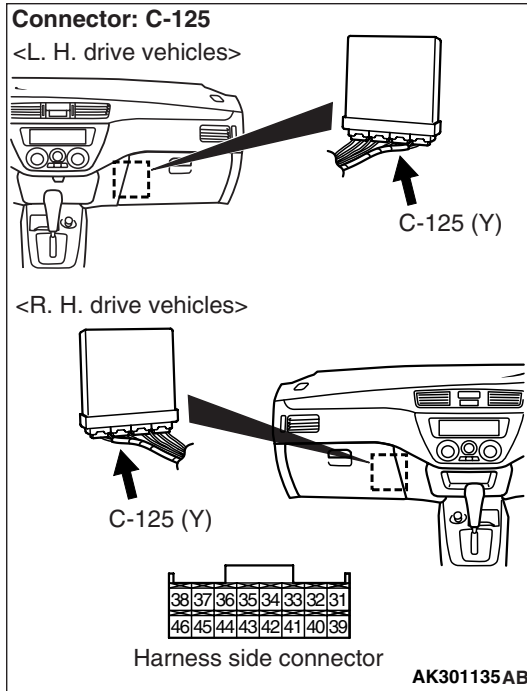

Q: Is the check result normal?

YES : Go to Step 6 .

NO : Repair or replace.

STEP 6. Check harness between B-115 (terminal No. 1) power steering fluid pressure switch connector and C-125 (terminal No. 37) engine-ECU <M/T> connector or C-124 (terminal No. 52) engine-A/T-ECU <A/T> connector.

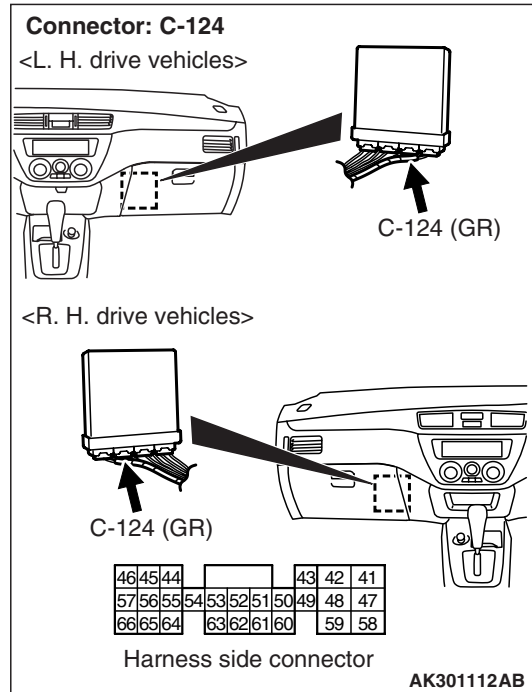
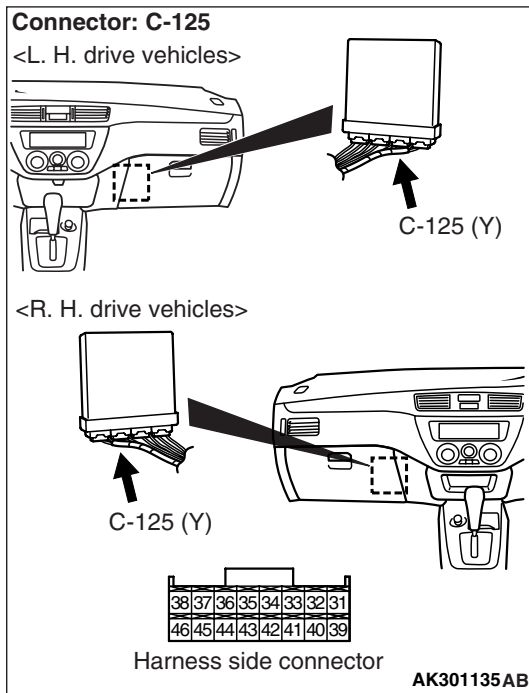
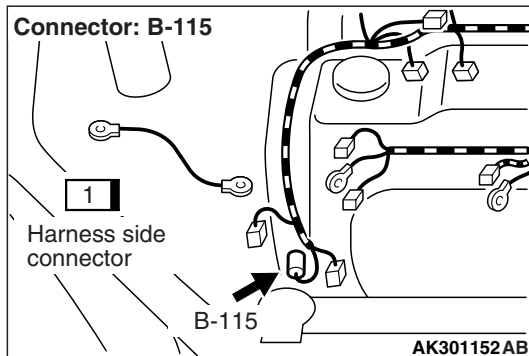

- Check output line for short circuit.

Q: Is the check result normal?

YES : Go to Step 7 .

NO : Repair.

STEP 7. M.U.T.-II/III data list

- Refer to data list reference table [P.13A-376](#).
 - a. Item 27: Power steering fluid pressure switch

Q: Is the check result normal?

YES : Intermittent malfunction (Refer to GROUP 00 –How to Use Troubleshooting/Inspection Service Points [P.00-5](#)).

NO : Replace engine-ECU <M/T> or engine-A/T-ECU <A/T>.

STEP 8. Perform voltage measurement at C-125 engine-ECU <M/T> connector or C-124 engine-A/T-ECU <A/T> connector.

Q: Is the check result normal?

- YES : Go to Step 11 .
- NO : Go to Step 9 .

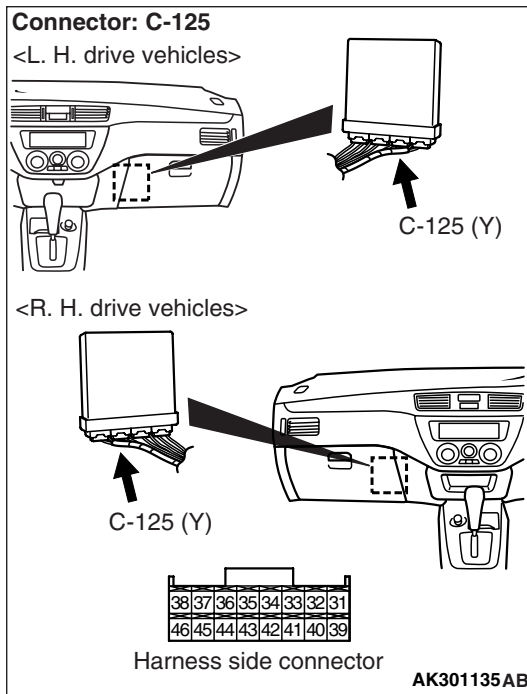

STEP 9. Connector check: C-125 engine-ECU <M/T> connector or C-124 engine-A/T-ECU <A/T> connector

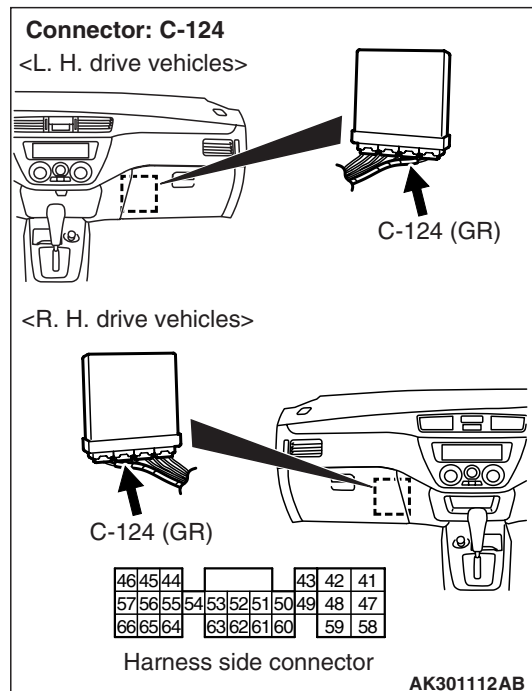
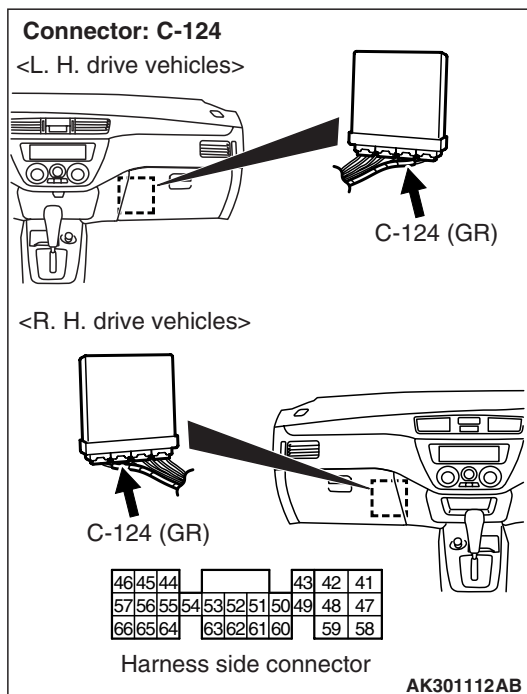
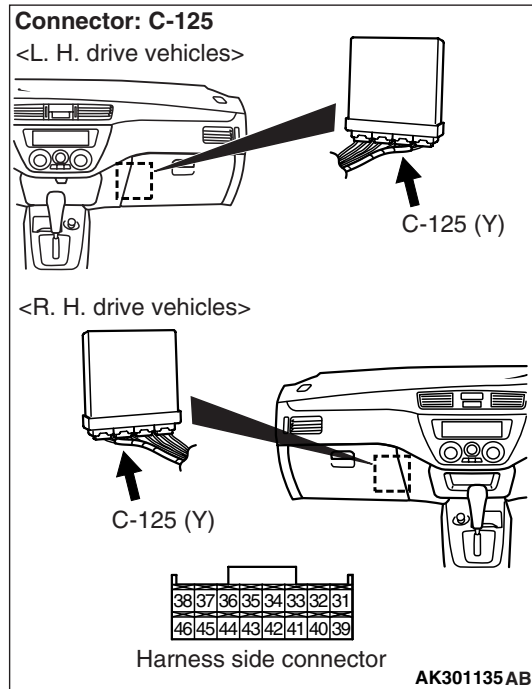

- Measure engine-ECU <M/T> or engine-A/T-ECU <A/T> terminal voltage.
- Engine: Idling
- Voltage between terminal No. 37 <M/T> or terminal No. 52 <A/T> and earth.

OK:

**System voltage (Steering wheel: Stationary)
1 V or less (Steering wheel: Turned)**

Q: Is the check result normal?

- YES : Go to Step 10 .
- NO : Repair or replace.

STEP 10. Check harness between B-115 (terminal No. 1) power steering fluid pressure switch connector and C-125 (terminal No. 37) engine-ECU <M/T> connector or C-124 (terminal No. 52) engine-A/T-ECU <A/T> connector.

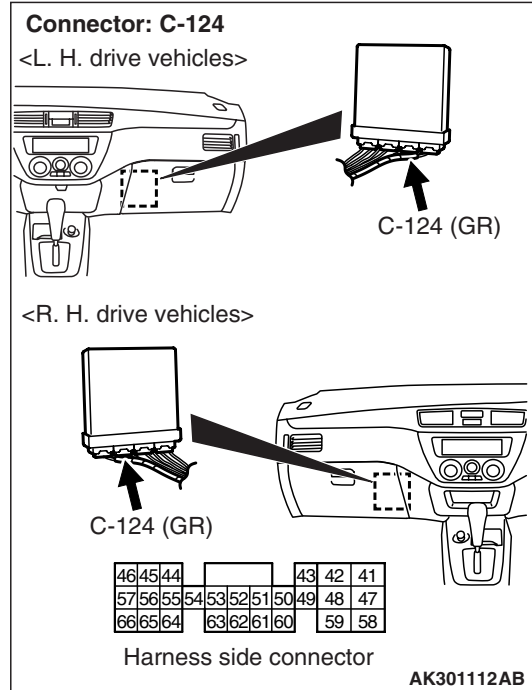
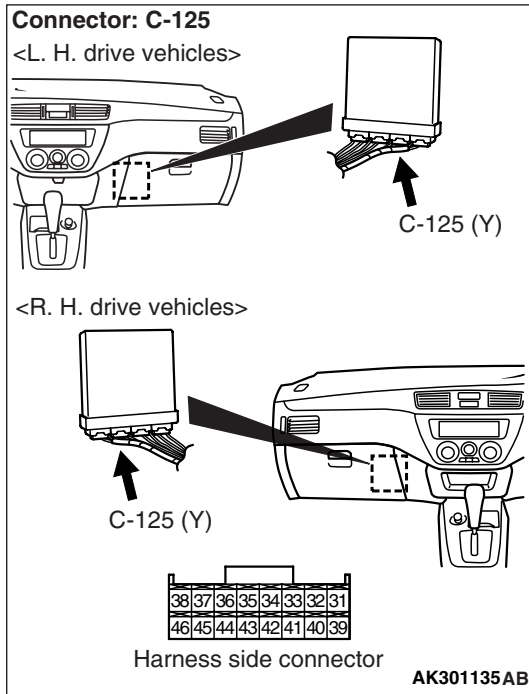
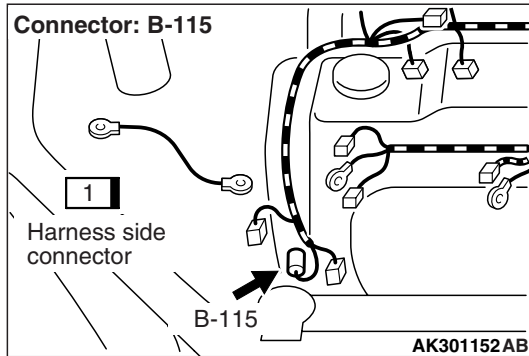

- Check output line for damage.
- Q: Is the check result normal?**
YES : Replace power steering fluid pressure switch.
NO : Repair.

STEP 11. Connector check: C-125 engine-ECU <M/T> connector or C-124 engine-A/T-ECU <A/T> connector

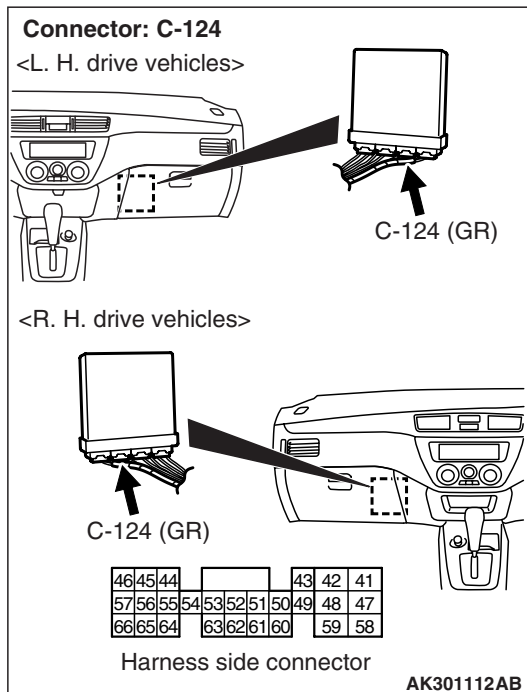
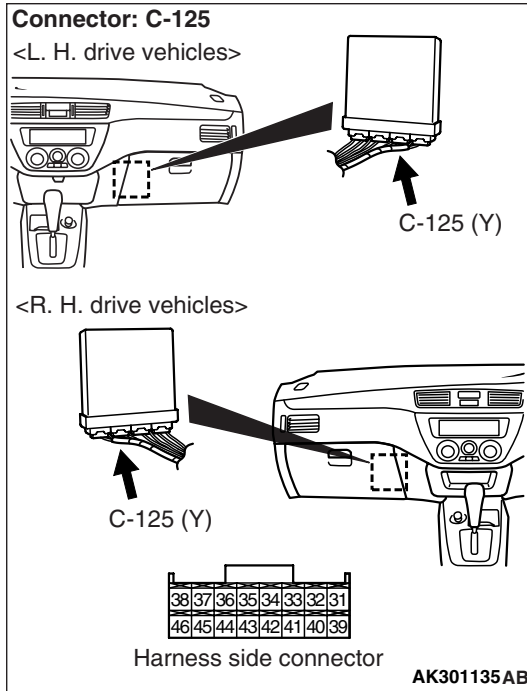

Q: Is the check result normal?

YES : Go to Step 7 .

NO : Repair or replace.

Code No. P0622: Alternator FR Terminal System

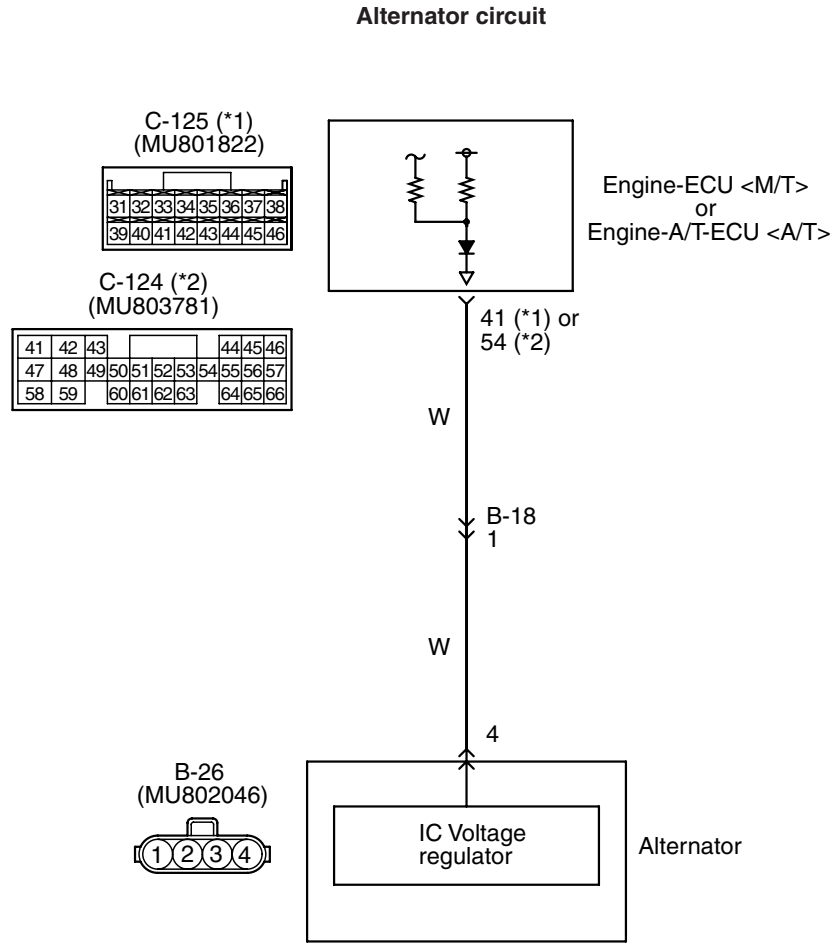

NOTE
*1: M/T
*2: A/T

Wire colour code
B: Black LG: Light green G: Green L: Blue W: White Y: Yellow SB: Sky blue BR: Brown O: Orange GR: Gray
R: Red P: Pink V: Violet

AK301153AB

OPERATION

- The energized state of the alternator field coil is inputted from the alternator (terminal No. 4) to the engine-ECU (terminal No. 41) <M/T> or engine-A/T-ECU (terminal No. 54) <A/T>.

FUNCTION

- A signal of the power supply duty ratio for the alternator field coil is inputted to the engine-ECU <M/T> or engine-A/T-ECU <A/T>.
- In response to the signal, the engine-ECU <M/T> or engine-A/T-ECU <A/T> detects the alternator output current and controls the idling speed according to the output current (electric load).

TROUBLE JUDGMENT

Check Condition

- Engine speed is 50 r/min or more.

Judgment Criterion

- Input voltage from alternator FR terminal is the system voltage or more for 20 seconds.

PROBABLE CAUSE

- Open circuit in alternator FR terminal circuit
- Failed engine-ECU <M/T>
- Failed engine-A/T-ECU <A/T>

DIAGNOSIS PROCEDURE

STEP 1. Connector check: B-18 intermediate connector

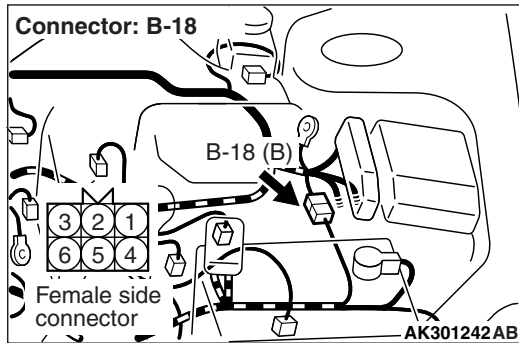

- Q: Is the check result normal?**
YES : Go to Step 2 .
NO : Repair or replace.

STEP 2. Perform voltage measurement at B-18 intermediate connector.

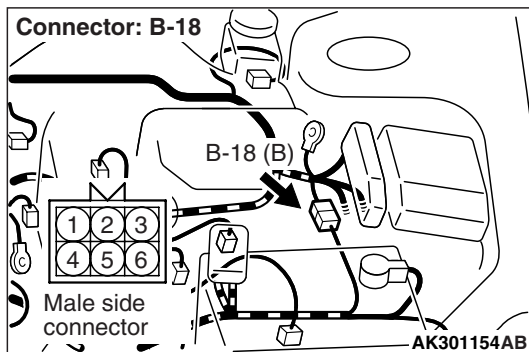

- Disconnect connector, and measure at male connector side.
- Ignition switch: ON
- Voltage between terminal No. 1 and earth.
OK: System voltage

- Q: Is the check result normal?**
YES : Go to Step 6 .
NO : Go to Step 3 .

STEP 3. Connector check: C-125 engine-ECU <M/T> connector or C-124 engine-A/T-ECU <A/T> connector

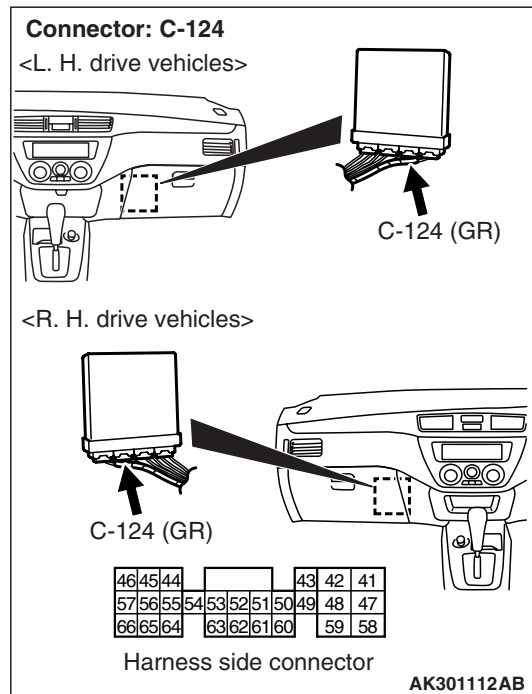
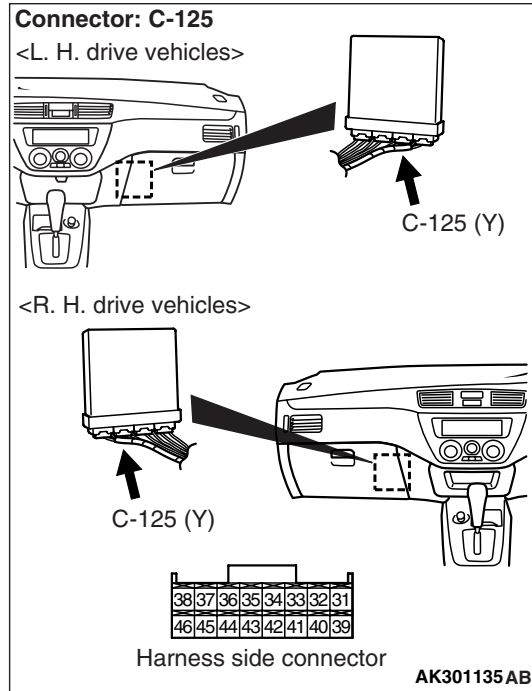

- Q: Is the check result normal?**
YES : Go to Step 4 .
NO : Repair or replace.

STEP 4. Check harness between B-18 (terminal No. 1) intermediate connector and C-125 (terminal No. 41) engine-ECU <M/T> connector or C-124 (terminal No. 54) engine-A/T-ECU <A/T> connector.

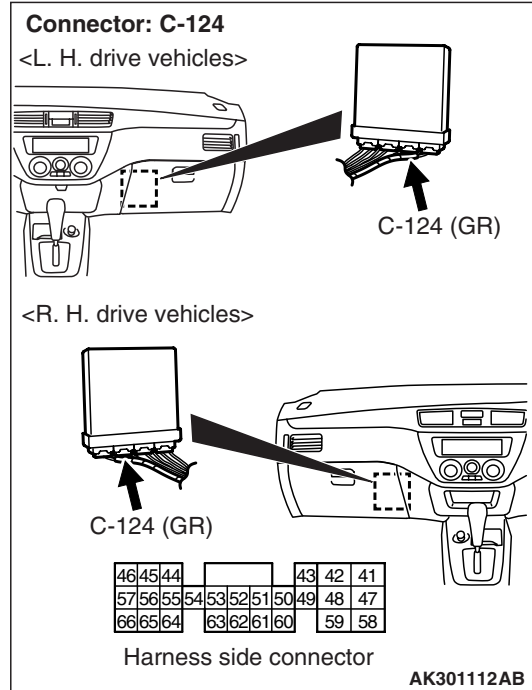
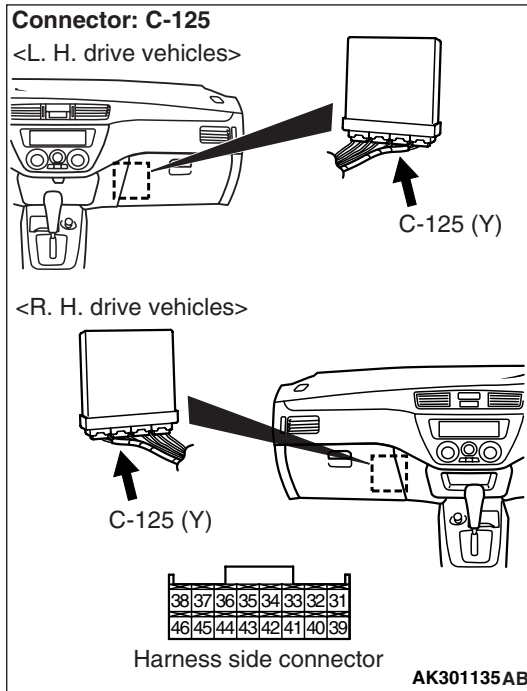
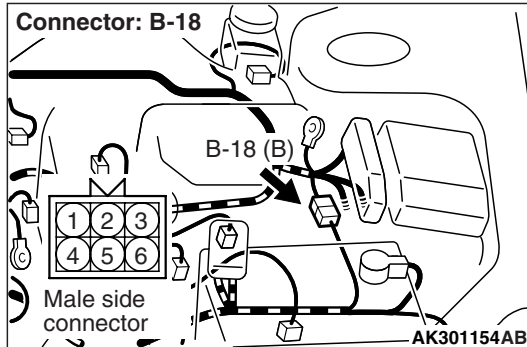

- Check output line for short circuit.

Q: Is the check result normal?

YES : Go to Step 5 .

NO : Repair.

STEP 5. Check the trouble symptoms.

Q: Does trouble symptom persist?

YES : Replace engine-ECU <M/T> or engine-A/T-ECU <A/T>.

NO : Intermittent malfunction (Refer to GROUP 00 –How to Use Troubleshooting/Inspection Service Points P.00-5).

STEP 6. Perform voltage measurement at B-18 intermediate connector.

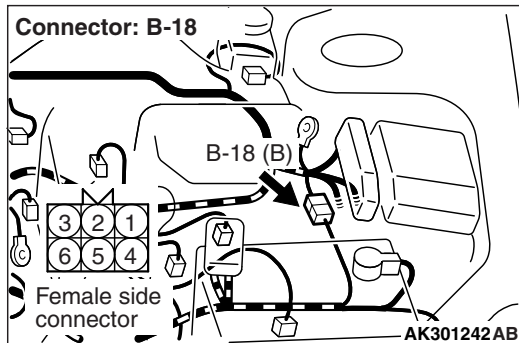

- Use special tool test harness (MB991658) to connect connector, and measure at pick-up harness.
- Ignition switch: ON
- Voltage between terminal No. 1 and earth.

OK: System voltage

Q: Is the check result normal?

- YES :** Go to Step 9 .
NO : Go to Step 7 .

STEP 7. Connector check: B-26 alternator connector

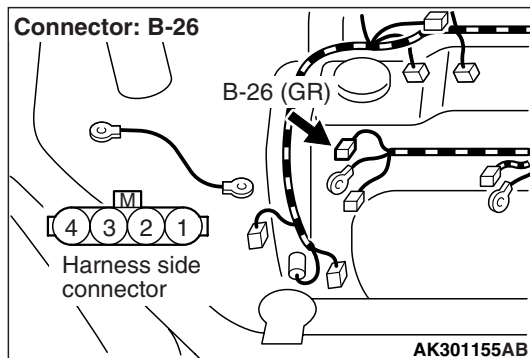

- Check output line for short circuit.

Q: Is the check result normal?

- YES :** Replace alternator.
NO : Repair.

Q: Is the check result normal?

- YES :** Go to Step 8 .
NO : Repair or replace.

STEP 8. Check harness between B-26 (terminal No. 4) alternator connector and B-18 (terminal No. 1) intermediate connector.

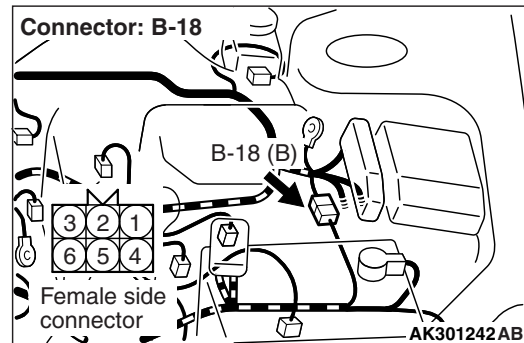
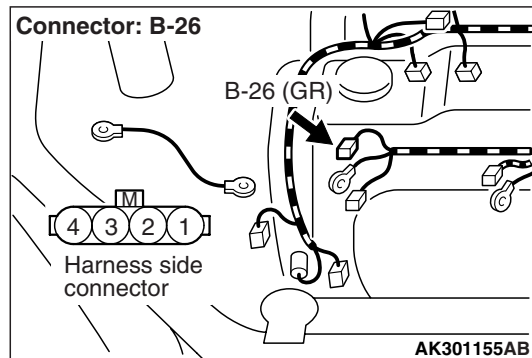

STEP 9. Perform voltage measurement at B-18 intermediate connector.

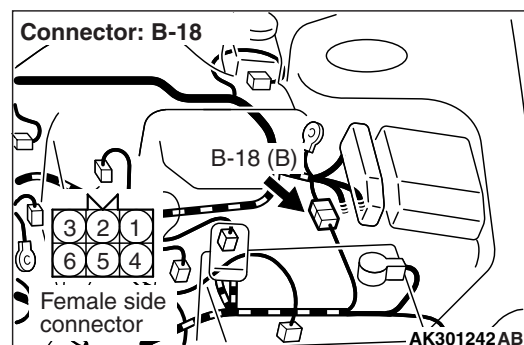

- Use special tool test harness (MB991658) to connect connector, and measure at pick-up harness.
- Engine: Idle after warm-up
- Transmission: Neutral <M/T> or P range <A/T>
- Radiator fan: Inactive
- Voltage between terminal No. 1 and earth.

OK: Switching the headlamps to ON from OFF causes the voltage to fall.

Q: Is the check result normal?

YES : Go to Step 5 .

NO : Go to Step 10 .

STEP 10. Connector check: B-26 alternator connector

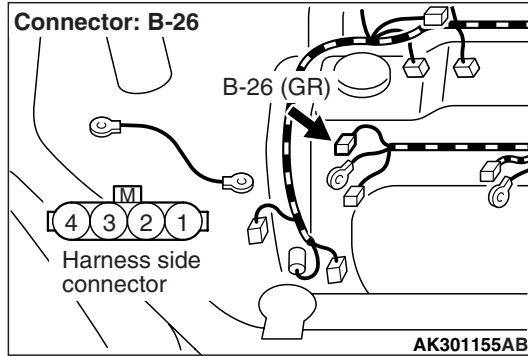

Q: Is the check result normal?

YES : Go to Step 11 .

NO : Repair or replace.

STEP 11. Check harness between B-26 (terminal No. 4) alternator connector and B-18 (terminal No. 1) intermediate connector.

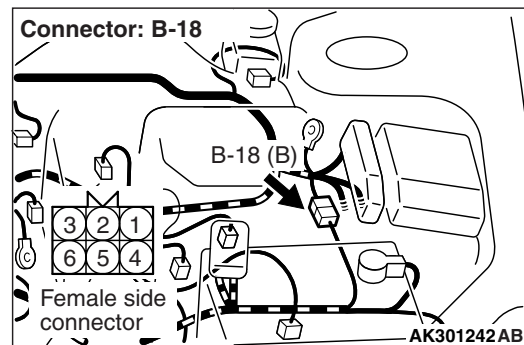
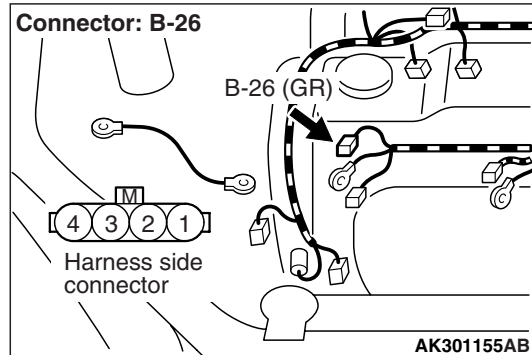

- Check output line for damage.

Q: Is the check result normal?

YES : Go to Step 12 .

NO : Repair.

STEP 12. Check harness between B-18 (terminal No. 1) intermediate connector and C-125 (terminal No. 41) engine-ECU <M/T> connector or C-124 (terminal No. 54) engine-A/T-ECU <A/T> connector.

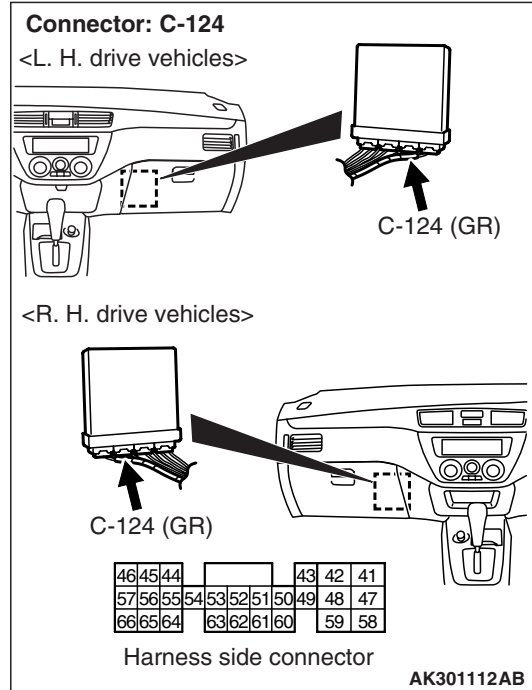
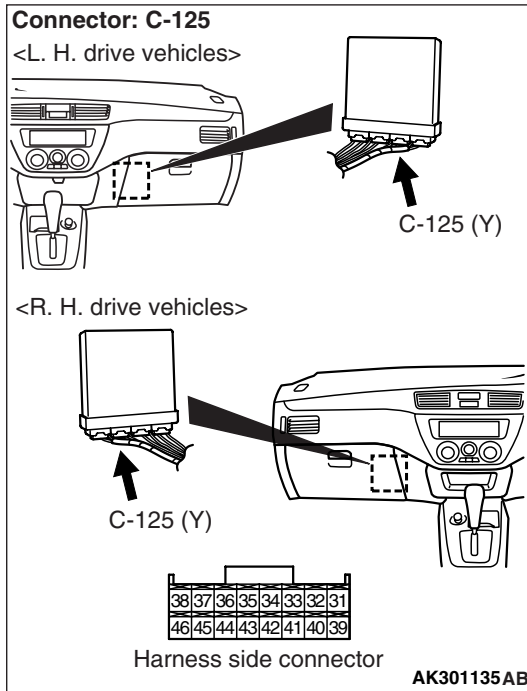
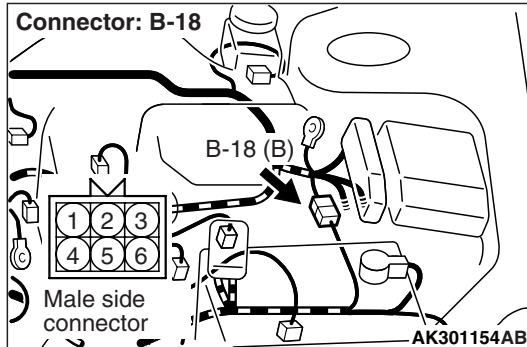

- Check output line for damage.

Q: Is the check result normal?

YES : Go to Step 13 .

NO : Repair.

STEP 13. Check the trouble symptoms.

Q: Do trouble symptoms persist?

YES : Replace alternator.

NO : Intermittent malfunction (Refer to Group 00 – How to Use troubleshooting/Inspection Service Points P.00-5).

Code No. P1603: Battery Back-up Line System

Battery back-up circuit

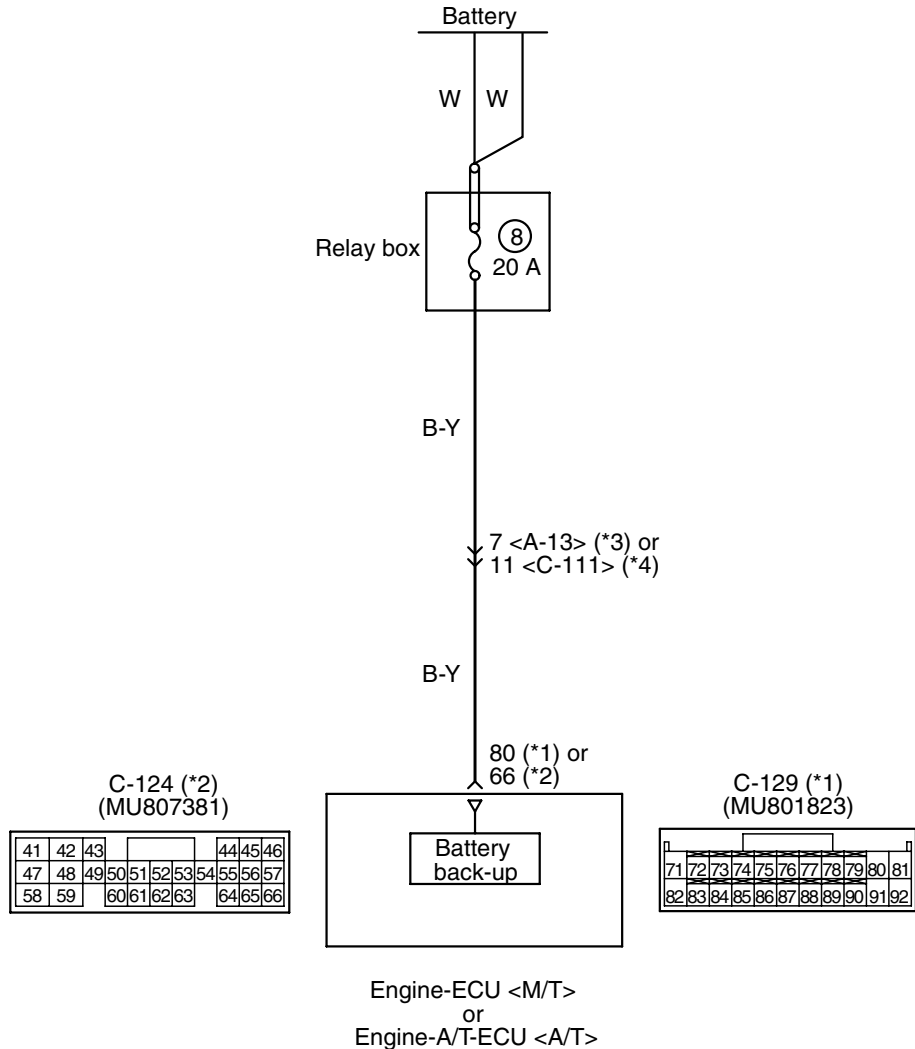

NOTE

- *1: M/T
- *2: A/T
- *3: L.H. drive vehicles
- *4: R.H. drive vehicles

Wire colour code

B: Black LG: Light green G: Green L: Blue W: White Y: Yellow SB: Sky blue BR: Brown O: Orange GR: Grey
R: Red P: Pink V: Violet

AK301156AC

OPERATION

- Power is directly supplied to the engine-ECU (terminal No. 80) <M/T> or engine-A/T-ECU (terminal No. 66) <A/T> from the battery.

FUNCTION

- The engine-ECU <M/T> or engine-A/T-ECU <A/T> is check the open circuit of battery back-up line.

TROUBLE JUDGMENT

Check Condition

- Ignition switch: ON

Judgment Criterion

- The battery back-up line voltage 6 V or less.

PROBABLE CAUSE

- Open/short circuit in battery back-up line circuit or loose connector contact
- Failed engine-ECU <M/T>
- Failed engine-A/T-ECU <A/T>

DIAGNOSIS PROCEDURE

NOTE:

- *1: L.H. drive vehicles
- *2: R.H. drive vehicles

STEP 1. M.U.T.-II/III diagnosis code

- Temporarily place the ignition switch in "LOCK" (OFF) position, and 10 seconds after that, place it in "ON" position again.

Q: Is the diagnosis code P1603 set?

YES : Go to Step 2 .

NO : Intermittent malfunction (Refer to GROUP 00 –How to use Troubleshooting/Inspection Service Points P.00-5).

STEP 2. Perform voltage measurement at C-129 engine-ECU <M/T> connector or C-124 engine-A/T-ECU <A/T> connector.

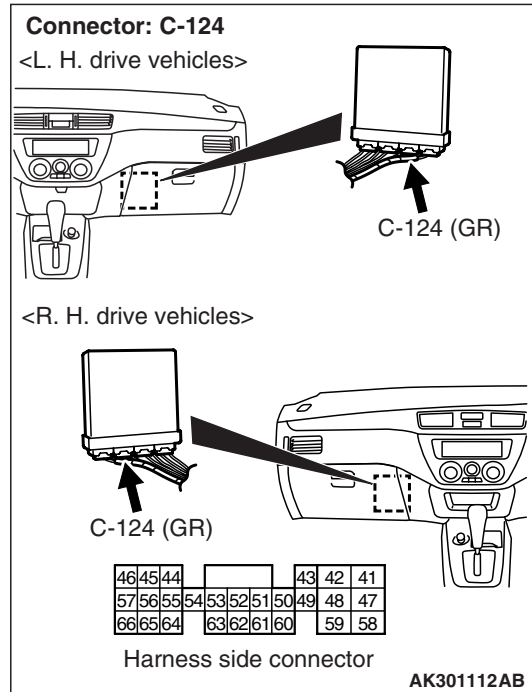
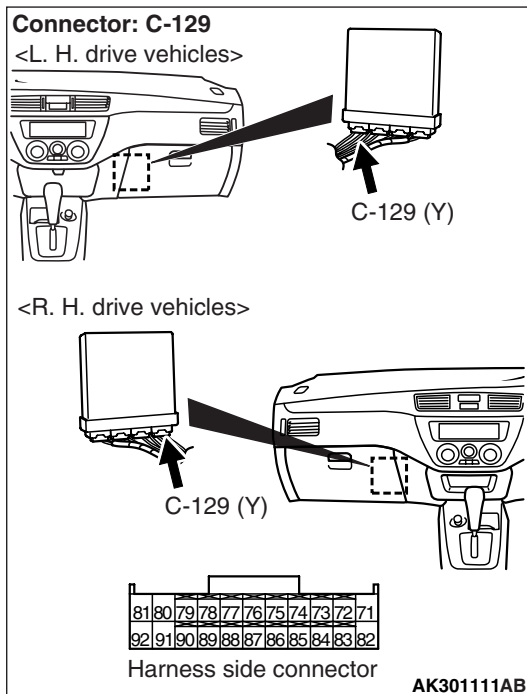

- Disconnect connector, and measure at harness side.
- Ignition switch: ON
- Voltage between terminal No. 80 <M/T> or terminal No. 66 <A/T> and earth.

OK: System voltage

Q: Is the check result normal?

YES : Go to Step 3 .

NO : Check intermediate connector A-13 *1 or C-111*2, and repair if necessary. If intermediate connector is normal, check and repair harness between battery and C-129 (terminal No. 80) engine-ECU <M/T> connector or C-124 (terminal No. 66) engine-A/T-ECU <A/T> connector.

- Check power supply line for open/short circuit.

STEP 3. Connector check: C-129 engine-ECU <M/T> connector or C-124 engine-A/T-ECU <A/T> connector

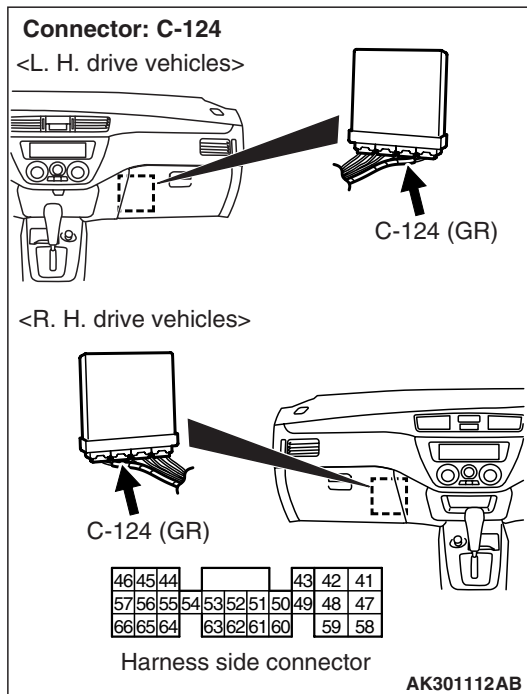
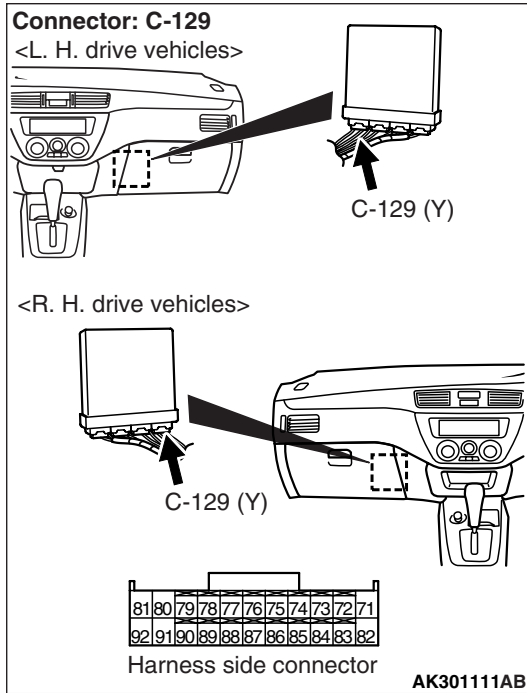

STEP 4. Check the trouble symptoms.

Q: Does trouble symptom persist?

YES : Replace engine-ECU <M/T> or engine-A/T-ECU <A/T>.

NO : Intermittent malfunction (Refer to GROUP 00 –How to Use Troubleshooting/Inspection Service Points P.00-5).

Q: Is the check result normal?

YES : Go to Step 4 .

NO : Repair or replace.

INSPECTION CHART FOR TROUBLE SYMPTOMS

Items	Trouble symptom		Inspection procedure No.
Communication with M.U.T.-II/III is impossible	Communication with all system is not possible		1
	Communication with engine-ECU <M/T> or engine-A/T-ECU <A/T> only is not possible		2
Engine warning lamp	The engine warning lamp does not illuminate right after the ignition switch is turned to the "ON" position		3
	The engine warning lamp remains illuminating and never goes out		4
Starting	Starting impossible (No initial combustion)	The starter is impossible to operate.	5
	Starting impossible (Starter operative but no initial combustion)	The starter is operative and cranks the engine, but none of initial combustion is in the cylinders and the engine is not started.	6
	Starting impossible (Initial combustion but no complete combustion)	The initial combustion occurs, but the engine stalls soon due to the incomplete combustion.	7
	Improper starting (Long time to start)	It is long cranking to start the engine.	
Improper idling	Unstable idling (Rough idling, hunting)	The engine speed is not constant and changeable during the idling. Usually, the judgment can be based on the movement of the tachometer pointer, also on the vibration transmitted to the steering wheel, shift lever, vehicle body and so on.	8
	Improper idling speed (Too high or too low)	The proper idling speed is not satisfied.	
	Engine stalls during idling (Die out)	The engine stalls during the idling in no relation to the vehicle movement.	
Engine stalls	The engine stalls when starting the car (Pass out)	The engine stalls during the operation, or when the accelerator pedal is depressed from the idling.	9
	The engine stalls when decelerating	The engine stalls at the deceleration.	10

Items	Trouble symptom		Inspection procedure No.
Driving	Engine does not revolve up	The engine speed is not higher when the accelerator pedal is depressed.	11
	Hesitation, sag	The response of vehicle speed (engine speed) is delayed when the accelerator pedal is depressed, or the vehicle speed (engine speed) is temporarily dropped during the acceleration. These phenomena are called "hesitation" and the serious hesitation is called "sag".	12
	Poor acceleration	The engine cannot obtain the acceleration corresponding to the degree of throttle opening although the engine is smooth at the constant speed.	
	Stumble	The engine speed increase is delayed when the accelerator pedal is initially depressed at the starting.	
	Surge	The vehicle body is repeated to vibrate jollity in the forward and backward directions at the constant speed or acceleration.	
	The feeling of impact or vibration when accelerating	The large impact feeling occurs at the acceleration.	
	The feeling of impact or vibration when decelerating	The large impact feeling occurs at the deceleration.	14
	Knocking	Sharp sound like a hammer striking on the cylinder walls during the driving can be heard and wrongly affects the driving.	15
Ignition timing offset	The basic ignition timing is deviated from the datum value.	16	
Stopping	Run on (Dieseling)	The engine continues to run after the ignition switch is in "LOCK (OFF)" position.	17
Exhaust gas	Odor, white smoke, black smoke, and high-concentration CO/HC during idling	The exhaust gas is extremely rank odor, white smoke or black smoke. The concentration of CO & HC is high during the idling.	18
Charging performance	Battery rundown	The battery is soon rundown or the charging ability of battery is small.	19

Items	Trouble symptom		Inspection procedure No.
Cooling performance	Overheating	The temperature of engine cooling water is extremely high.	20
	Abnormal rotation of fan motor	The fan motor is abnormally rotated when the ignition switch is in "ON" position in no relation to the engine cooling water temperature.	21
A/C performance	Poor A/C performance	The temperature of air cooling from A/C is not efficient or very far from the target temperature.	22

PROBLEM SYMPTOMS TABLE

Inspection procedure No.	Trouble symptom	Reference page
1	Communication with all system is not possible	P.13A-237
2	Communication with engine-ECU only is not possible	P.13A-240
3	The engine warning lamp does not illuminate right after the ignition switch is turned to the "ON" position	P.13A-243
4	The engine warning lamp remains illuminating and never goes out	P.13A-253
5	Starting impossible (No initial combustion)	P.13A-257 <M/T>, P.13A-264 <A/T>
6	Starting impossible (Starter operative but no initial combustion)	P.13A-271 <M/T>, P.13A-274 <A/T>
7	Starting impossible (Initial combustion but no complete combustion)	P.13A-277
	Improper starting (Long time to start)	
8	Unstable idling (Rough idling, hunting)	P.13A-281
	Improper idling speed (Too high or too low)	
	Engine stalls during idling (Die out)	
9	The engine stalls when starting the car (Pass out)	P.13A-292
10	The engine stalls when decelerating	P.13A-294
11	Engine does not revolve up	P.13A-297
12	Hesitation, sag	P.13A-298
	Poor acceleration	
	Stumble	
	Surge	
13	The feeling of impact or vibration when accelerating	P.13A-301
14	The feeling of impact or vibration when decelerating	P.13A-302
15	Knocking	P.13A-303

Inspection procedure No.	Trouble symptom	Reference page
16	Ignition timing offset	P.13A-305
17	Run on (Dieseling)	P.13A-306
18	Odor, white smoke, black smoke, and high-concentration CO/HC during idling	P.13A-306
19	Battery rundown	P.13A-308
20	Overheating	P.13A-315
21	Abnormal rotation of fan motor	P.13A-316
22	Poor A/C performance	P.13A-319
23	Engine-ECU<M/T> or engine-A/T-ECU<A/T> power supply, engine control relay, ignition switch-IG1 system	P.13A-321
24	Fuel pump system	P.13A-334
25	Fan control relay system	P.13A-344
26	A/C system	P.13A-352
27	A/C load signal system	P.13A-355
28	Ignition circuit system <L.H. drive vehicles>	P.13A-361
29	Ignition circuit system <R.H. drive vehicles>	P.13A-368

SYMPTOM PROCEDURES

Inspection Procedure 1: Communication with All System is not Possible

Diagnosis connector circuit

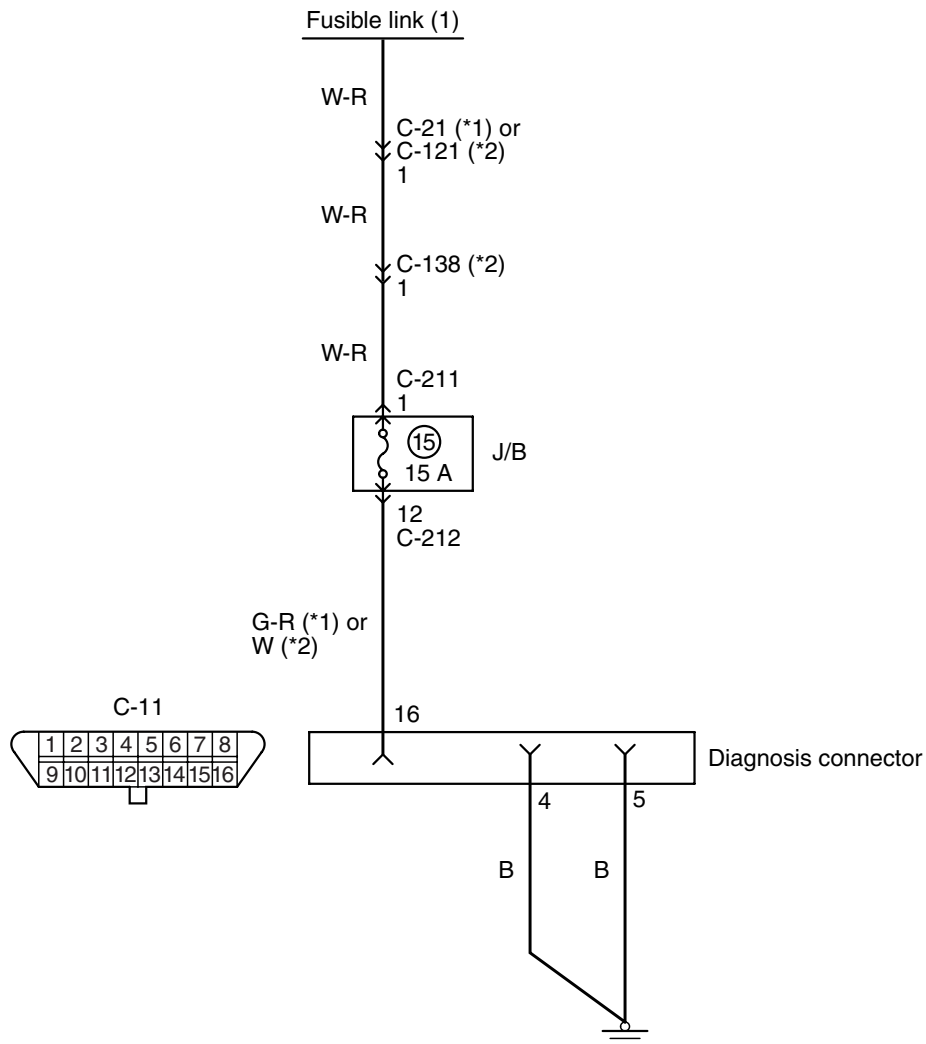

NOTE

- *1: L.H. drive vehicles
- *2: R.H. drive vehicles

Wire colour code

B: Black LG: Light green G: Green L: Blue W: White Y: Yellow SB: Sky blue BR: Brown O: Orange GR: Gray
R: Red P: Pink V: Violet

AK301341AB

OPERATION

- Battery voltage is applied to diagnosis connector (terminal No.16).
- Diagnosis connector (terminals No. 4 and 5) are earthed to the vehicle body.

COMMENT ON TROUBLE SYMPTOM

- Failure is possibly caused by failed power supply circuit or failed earthing circuit of diagnosis connector.

PROBABLE CAUSE

- Failed diagnosis connector
- Open/short circuit in diagnosis connector circuit
- Failed M.U.T.-II/III

DIAGNOSIS PROCEDURE**NOTE:**

*1: L.H. drive vehicles

*2: R.H. drive vehicles

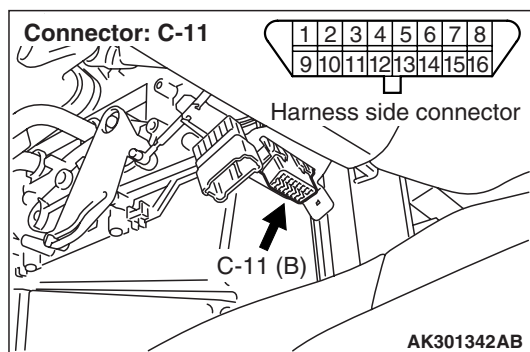
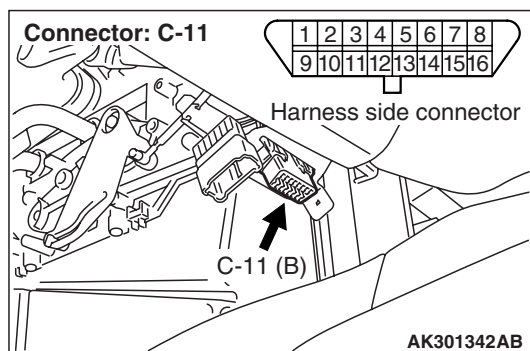
STEP 1. Check connector: C-11 diagnosis connector**Q: Is the check result normal?****YES :** Go to Step 2 .**NO :** Repair or replace.**STEP 2. Perform resistance measurement at C-11 diagnosis connector.**

- Disconnect connector, and measure at harness side.
- Resistance between terminal No. 4 and earth, also between terminal No. 5 and earth.

OK: Continuity (2 Ω or less)**Q: Is the check result normal?****YES :** Go to Step 3 .**NO :** Check and repair harness between C-11 (terminal No. 4) diagnosis connector and body earth, also between C-11 (terminal No. 5) diagnosis connector and body earth.

- Check earthing line for open circuit and damage.

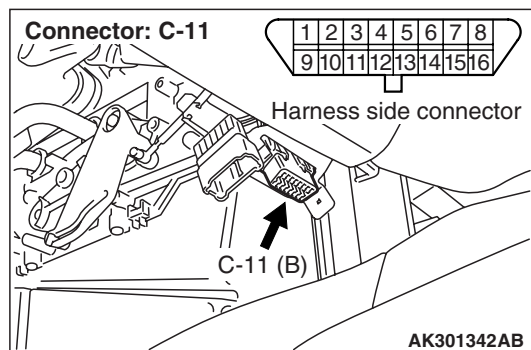
STEP 3. Perform voltage measurement at C-11 diagnosis connector.

- Disconnect connector, and measure at the harness side.
- Voltage between terminal No. 16 and earth.

OK: System voltage**Q: Is the check result normal?****YES :** Go to Step 4 .**NO :** Check intermediate connectors C-21*¹ or C-121*², C-138*², C-211 and C-212, and repair if necessary. If connectors are normal, check and repair harness between C-24 (terminal No. 16) diagnosis connector and battery.

- Check power supply line for open/short circuit.

STEP 4. Replace M.U.T.-II/III.

- After replacing the M.U.T.-II/III, re-check the trouble symptoms.

Q: Does trouble symptom persist?**YES :** Go to Step 5 .**NO :** Check end

STEP 5. Check harness between C-11 (terminal No. 16) diagnosis connector and battery.

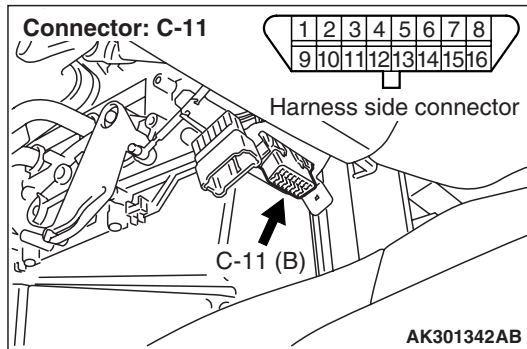

NOTE: Before checking harness, check intermediate connectors C-21*¹ or C-121*², C-138*², C-211 and C-212, and repair if necessary.

- Check power supply line for damage.

Q: Is the check result normal?

YES : Check and repair harness between C-11 (terminal No. 4 and No. 5) diagnosis connector and body earth.

- Check earthing line for damage.

NO : Repair.

Inspection Procedure 2: Communication with Engine-ECU <M/T> or Engine-A/T-ECU <A/T> Only is Not Possible.

Diagnosis connector circuit

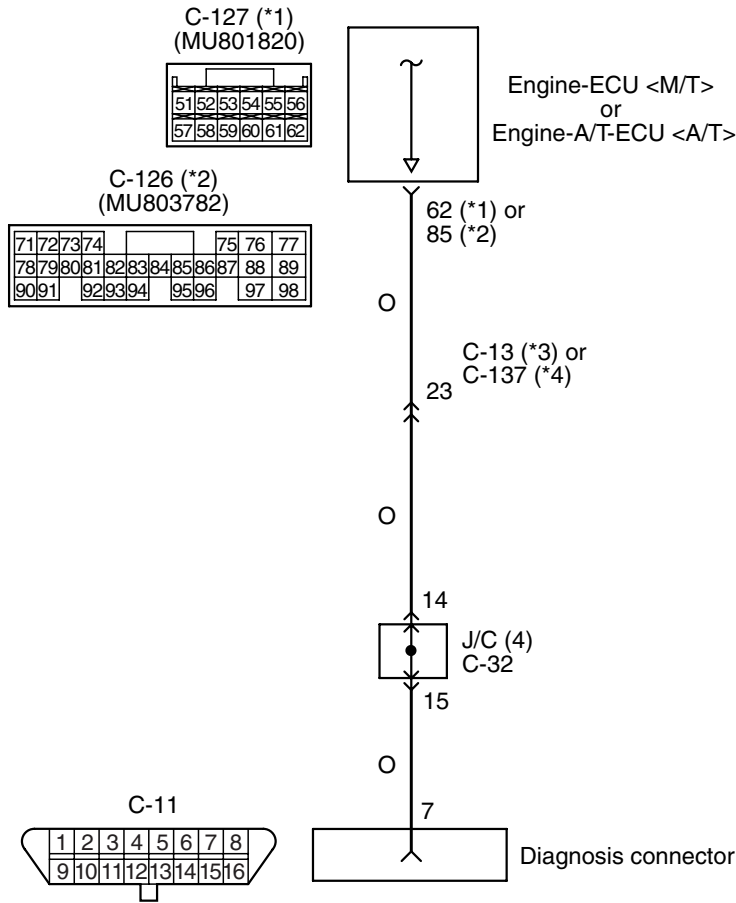

NOTE

- *1: M/T
- *2: A/T
- *3: L.H. drive vehicles
- *4: R.H. drive vehicles

Wire colour code

B: Black LG: Light green G: Green L: Blue W: White Y: Yellow SB: Sky blue BR: Brown O: Orange GR: Gray
R: Red P: Pink V: Violet

AK401360AB

OPERATION

- There is data communication between diagnosis connector output terminal (terminal No. 7) and engine-ECU (terminal No. 62) <M/T> or engine-A/T-ECU (terminal No. 85) <A/T>.

COMMENT ON TROUBLE SYMPTOM

- Failure is possibly caused by failed power supply circuit or failed earthing circuit of engine-ECU <M/T> or engine-A/T-ECU <A/T>.

PROBABLE CAUSE

- Open/short circuit in engine-ECU <M/T> or engine-A/T-ECU <A/T> power circuit
- Short circuit in diagnosis connector circuit
- Failed engine-ECU <M/T>
- Failed engine-A/T-ECU <A/T>

DIAGNOSIS PROCEDURE

NOTE:

- *1: L.H. drive vehicles
- *2: R.H. drive vehicles

STEP 1. Check engine warning lamp.

- Ignition switch: OFF → ON

Q: Is lamp illuminating for few seconds?

YES : Go to Step 2 .

NO : Check engine-ECU <M/T> or engine-A/T-ECU <A/T> power supply, engine control relay and ignition switch IG1 system (Refer to Inspection Procedure 23 P.13A-321).

STEP 2. Connector check: C-127 engine-ECU <M/T> connector or C-126 engine-A/T-ECU <A/T> connector

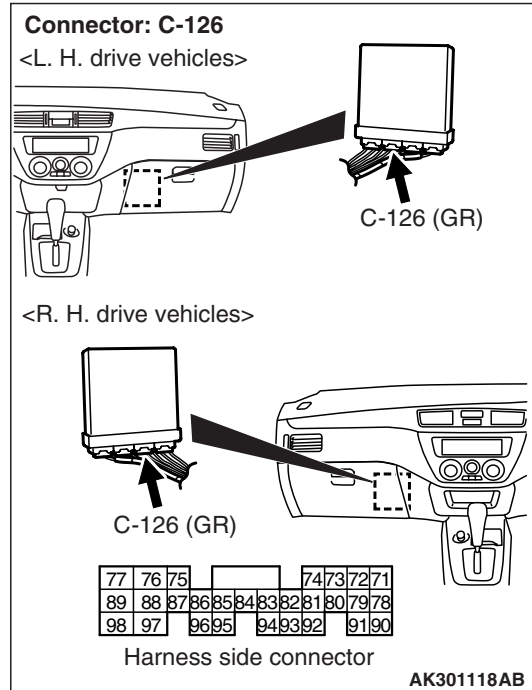
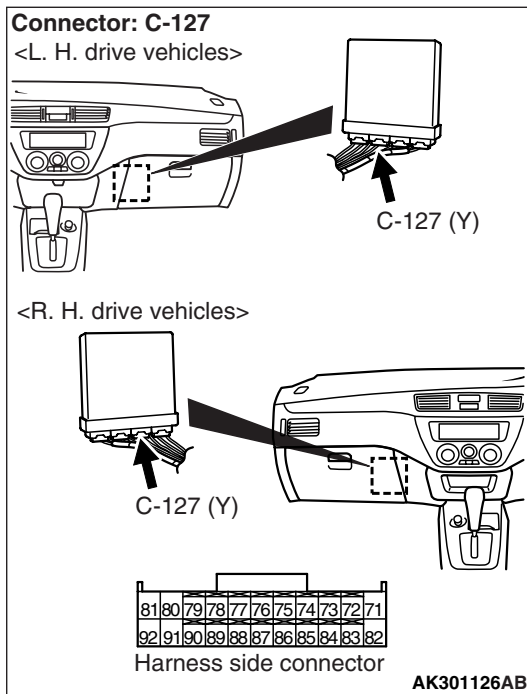

Q: Is the check result normal?

YES : Go to Step 3 .

NO : Repair or replace.

STEP 3. Check harness between C-11 (terminal No. 7) diagnosis connector and C-127 (terminal No. 62) engine-ECU <M/T> connector or C-126 (terminal No. 85) engine-A/T-ECU <A/T> connector.

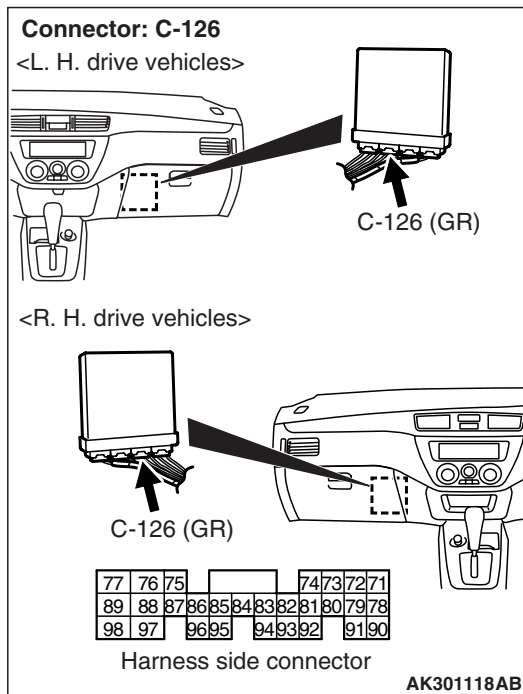
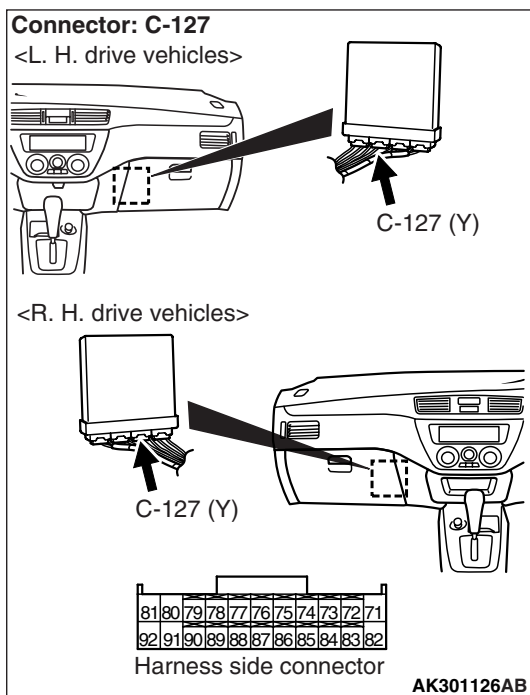
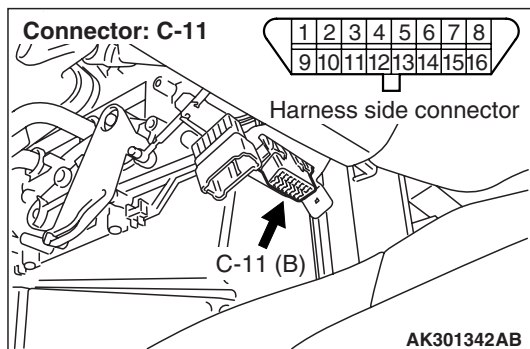

NOTE: Before Checking harness, check intermediate connectors C-13*¹ or C-137*² and C-32, and repair if necessary.

- Check communication line for open/short circuit and damage.

Q: Is the check result normal?

YES : Go to Step 4 .

NO : Repair or replace.

STEP 4. Check the trouble symptom.

Q: Does trouble symptom persist?

YES : Replace engine-ECU <M/T> or engine-A/T-ECU <A/T>.

NO : Intermittent malfunction (Refer to GROUP 00 –How to Use Troubleshooting/Inspection Service Points P.00-5).

Inspection Procedure 3: The Engine Warning Lamp Does Not Illuminate Right after the Ignition Switch Is Turned to the "ON" Position

Engine warning lamp (check engine lamp) circuit

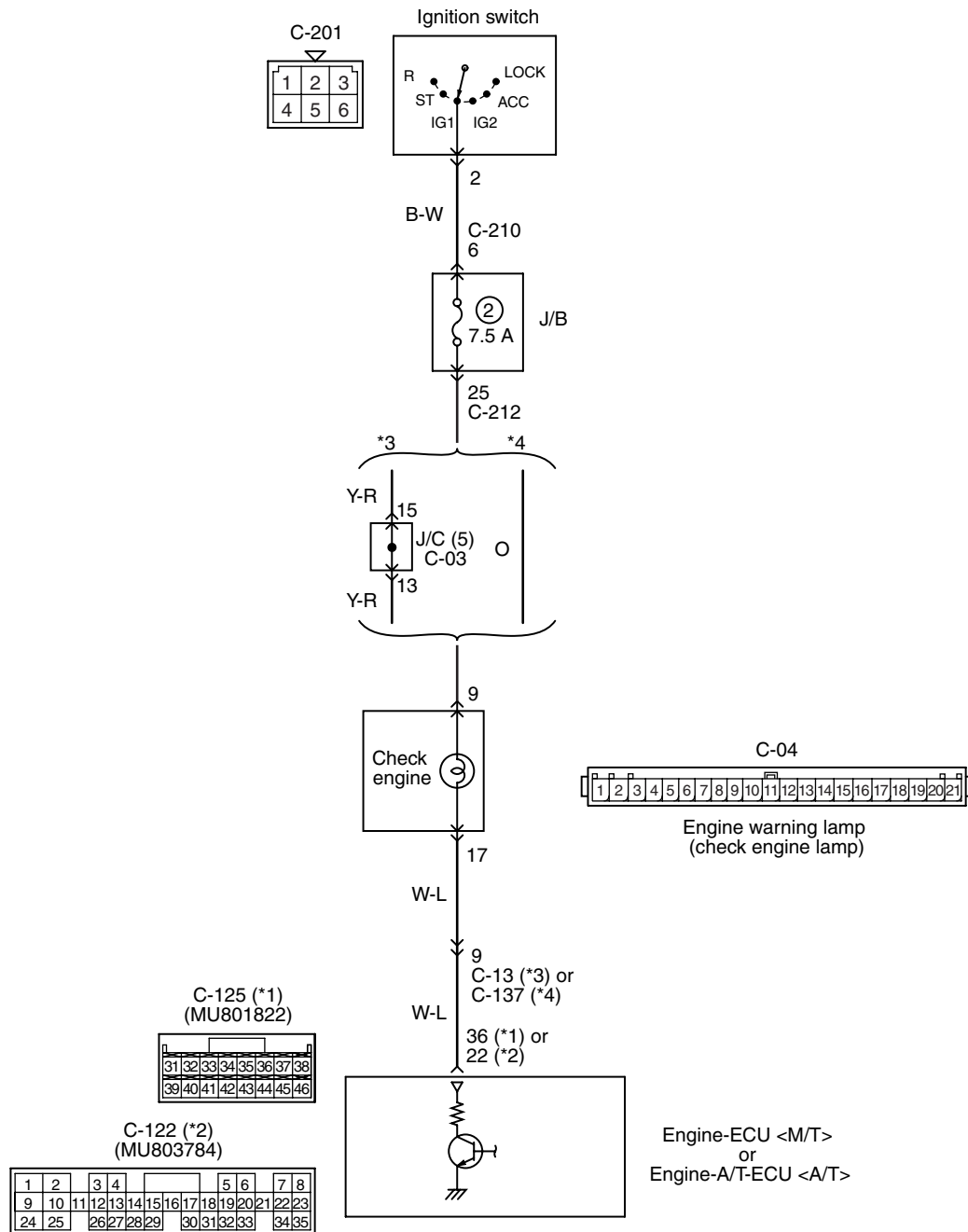

NOTE

- *1: M/T
- *2: A/T
- *3: L.H. drive vehicles
- *4: R.H. drive vehicles

Wire colour code

B: Black LG: Light green G: Green L: Blue W: White Y: Yellow SB: Sky blue BR: Brown O: Orange GR: Gray
R: Red P: Pink V: Violet

OPERATION

- Battery voltage is applied to engine warning lamp of combination meter connector (terminal No. 9) from ignition switch.
- Engine-ECU (terminal No. 36) <M/T> or engine-A/T-ECU (terminal No. 22) <A/T> makes power transistor in unit be in "ON" position, and that makes currents go on engine warning lamp of combination meter connector (terminal No. 17).

COMMENTS ON TROUBLE SYMPTOM

- Engine-ECU <M/T> or engine-A/T-ECU <A/T> turns on engine warning lamp for 5 seconds to check for burnt-out bulb immediately after ignition switch is turned to ON.
- If engine warning lamp is not lit just after turning ignition switch to "ON" position, failure is possibly caused by burnt-out bulb, open/short circuit or other faults.

PROBABLE CAUSE

- Engine warning lamp bulb burnt out
- Failed ignition switch
- Open/short circuit in engine warning lamp circuit for or loose connector contact
- Failed engine-ECU <M/T>
- Failed engine-A/T-ECU <A/T>

DIAGNOSIS PROCEDURE**NOTE:**

- *1: L.H. drive vehicles
- *2: R.H. drive vehicles

STEP 1. Check engine start-up.**Q: Is engine started?****YES** : Go to Step 2 .

NO : Check engine-ECU <M/T> or engine-A/T-ECU <A/T> power supply, engine control relay and ignition switch IG-1 system (Refer to Inspection Procedure 23 P.13A-321).

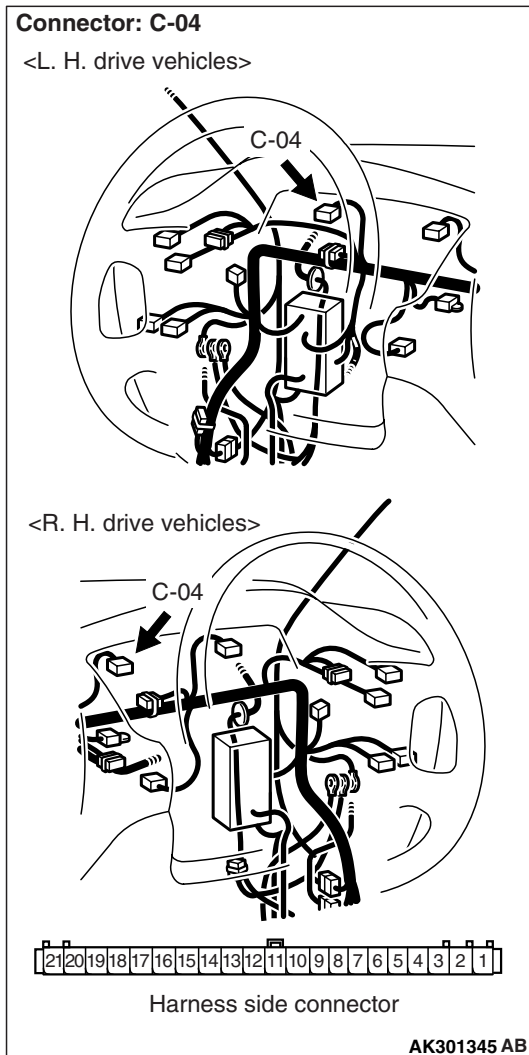
STEP 2. Check engine warning lamp for burnt-out bulb.**Q: Is the check result normal?****YES** : Go to Step 3 .**NO** : Replace engine warning lamp.**STEP 3. Connector check: C-04 combination meter connector****Q: Is the check result normal?****YES** : Go to Step 4 .**NO** : Repair or replace.

STEP 4. Perform voltage measurement at C-04 combination meter connector.

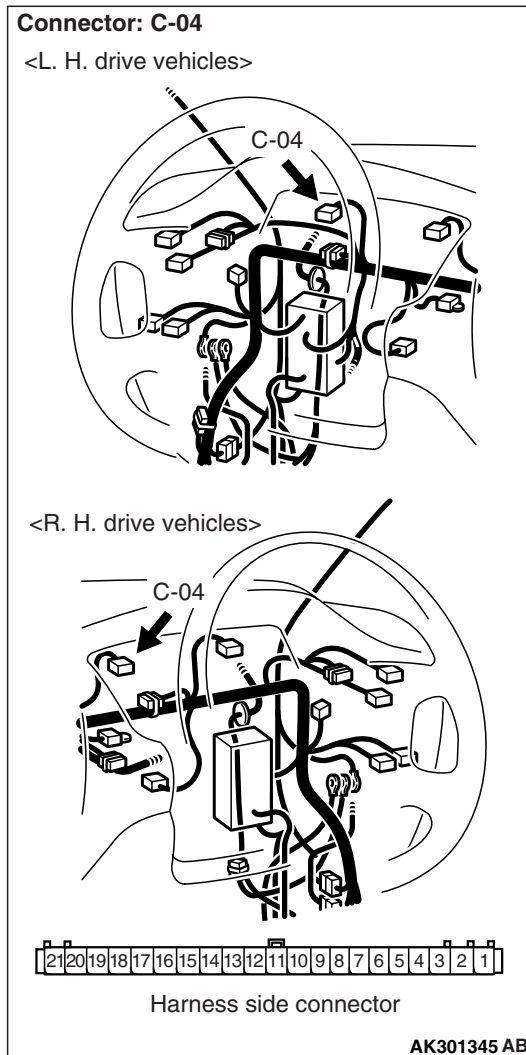

- Disconnect connector, and measure at the harness side.
- Ignition switch: ON
- Voltage between terminal No. 9 and earth.

OK: System voltage

Q: Is the check result normal?

YES : Go to Step 6 .

NO : Go to Step 5 .

STEP 5. Connector check: C-201 ignition switch connector

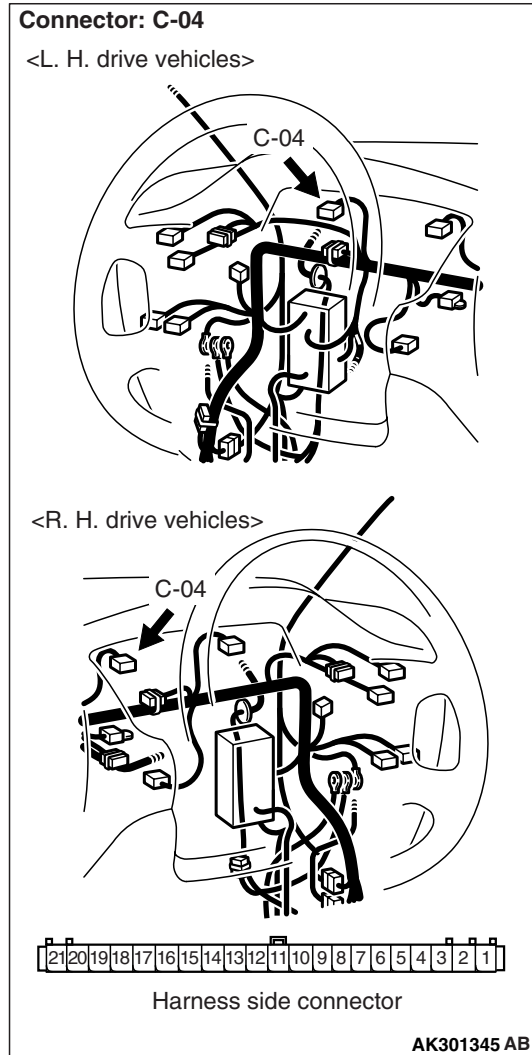
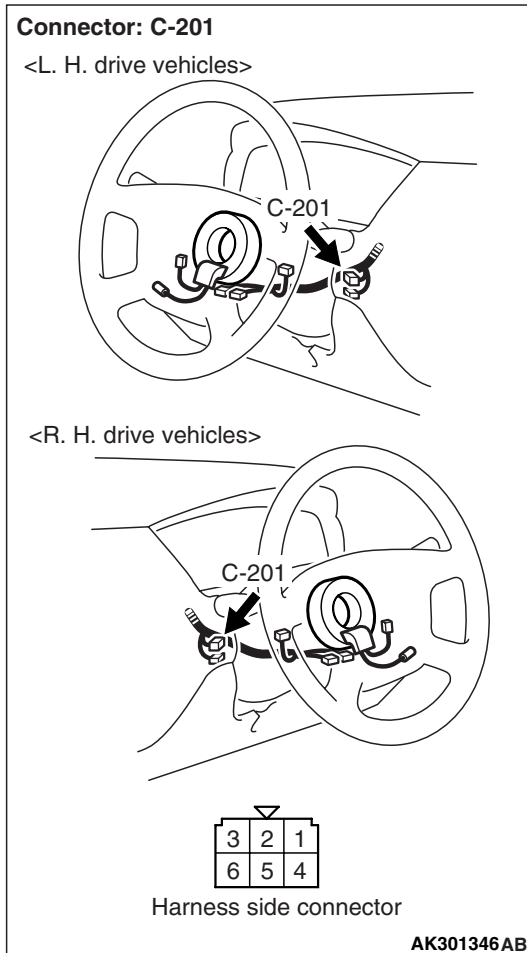

Q: Is the check result normal?

YES : Check intermediate connectors C-03*1, C-210 and C-212, and repair if necessary. If intermediate connectors are normal, check and repair harness between C-04 (terminal No. 9) combination meter connector and C-201 (terminal No. 2) ignition switch connector.

- Check power supply line for open/short circuit.

NO : Repair or replace.

STEP 6. Connector check: C-125 engine-ECU <M/T> connector or C-122 engine-A/T-ECU <A/T> connector

STEP 7. Perform voltage measurement at C-125 engine-ECU <M/T> connector or C-122 engine-A/T-ECU <A/T> connector.

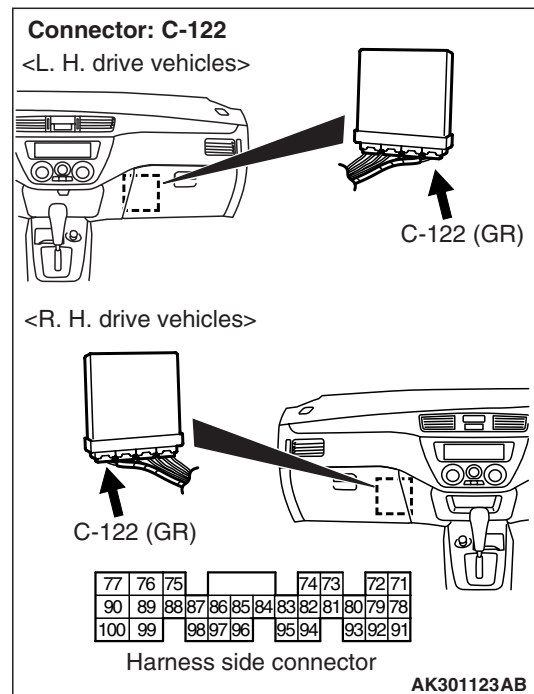
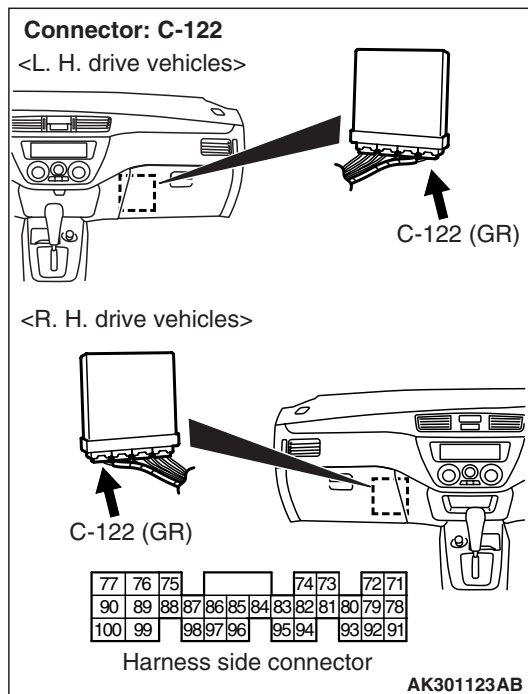
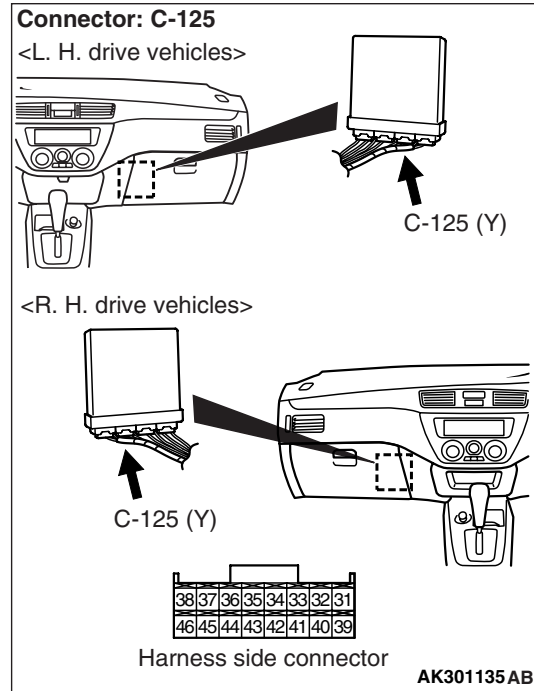
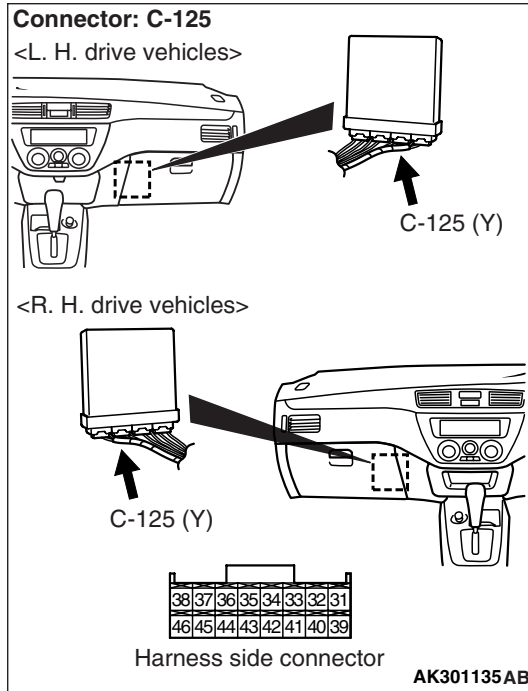

Q: Is the check result normal?
YES : Go to Step 7 .
NO : Repair or replace.

- Disconnect connector, and measure at the harness side.
- Ignition switch: ON
- Voltage between terminal No. 36 <M/T> or terminal No. 22 <A/T> and earth.

OK: System voltage

Q: Is the check result normal?
YES : Go to Step 9 .
NO : Go to Step 8 .

STEP 8. Check connector: C-04 combination meter connector

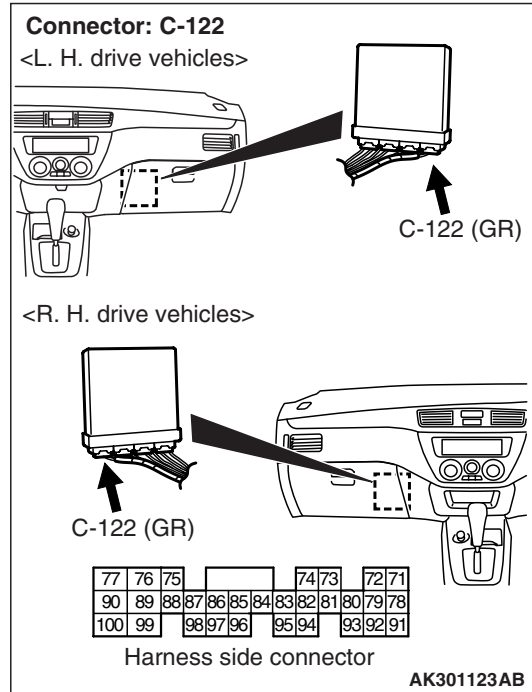
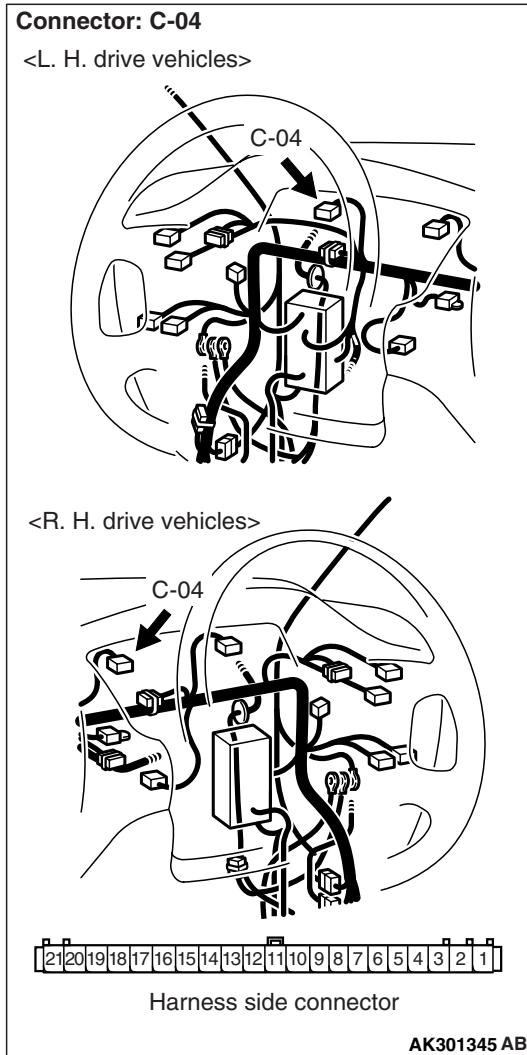

Q: Is the check result normal?

YES : Check intermediate connector C-13*¹ or C-137*², and repair if necessary. If intermediate connector is normal, check and repair harness between C-04 (terminal No. 17) combination meter connector and C-125 (terminal No. 36) engine-ECU <M/T> connector or C-122 (terminal No. 22) engine-A/T-ECU <A/T> connector.

- Check output line for open/short circuit.

NO : Repair or replace.

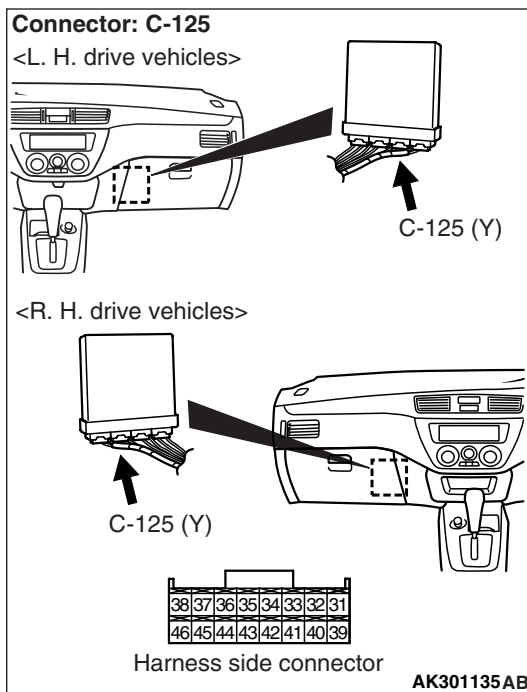

STEP 9. Connector check: C-201 ignition switch connector



Q: Is the check result normal?

YES : Go to Step 10 .

NO : Repair or replace.

STEP 10. Check harness between C-04 (terminal No. 9) combination connector and C-201 (terminal No. 2) ignition switch connector.

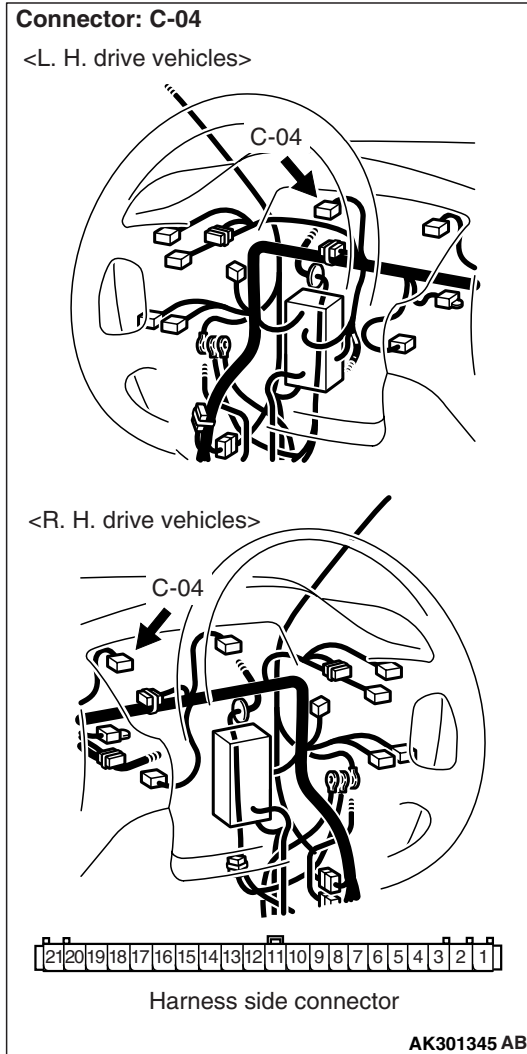

Connector: C-201

<L. H. drive vehicles>

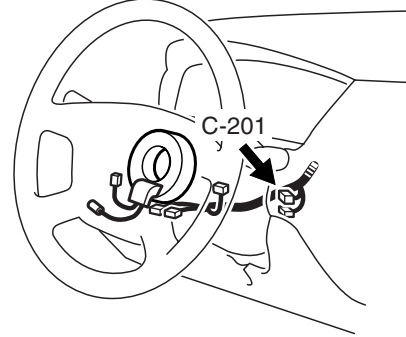

<R. H. drive vehicles>

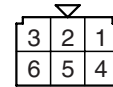
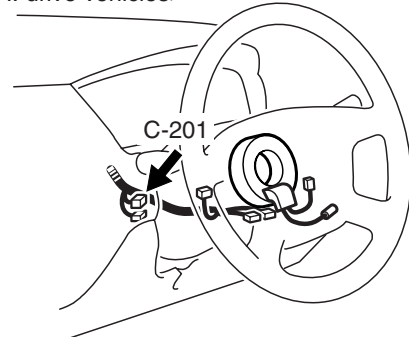

Harness side connector

AK301346 AB

NOTE: Before checking harness, check intermediate connectors C-212, C-03*¹ and C-210, and repair if necessary.

- Check power supply line for damage.

Q: Is the check result normal?

YES : Go to Step 11 .

NO : Repair.

STEP 11. Check harness between C-04 (terminal No. 17) combination connector and C-125 (terminal No. 36) engine-ECU <M/T> or C-122 (terminal No. 22) engine-A/T-ECU <A/T> connector.

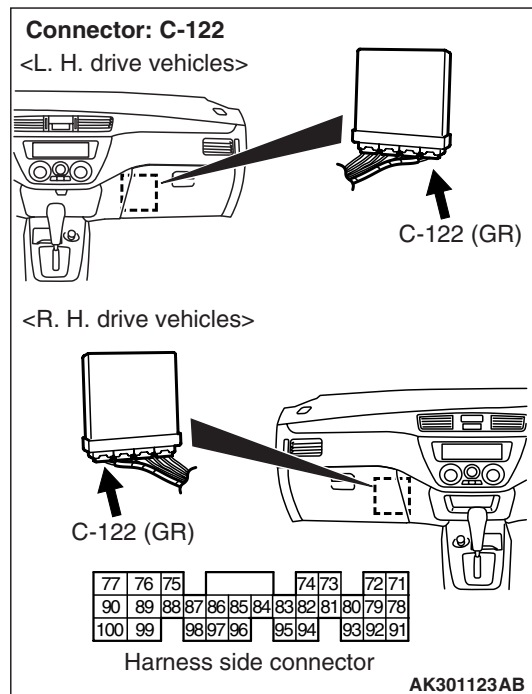
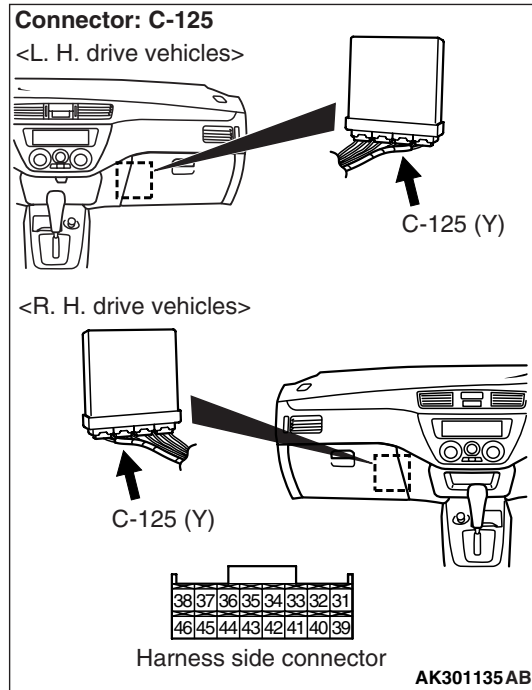
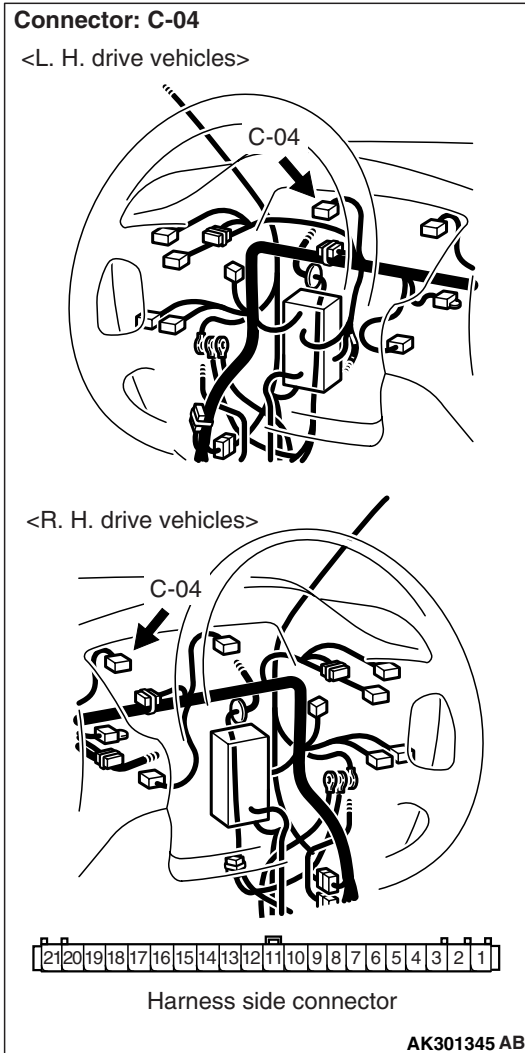

NOTE: Before checking harness, check intermediate connector C-13*¹ or C-137*², and repair if necessary.

- Check output line for damage.

Q: Is the check result normal?

YES : Go to Step 12 .

NO : Repair.

STEP 12. Check the trouble symptoms.**Q: Does trouble symptom persist?**

YES : Replace engine-ECU <M/T> or
engine-A/T-ECU <A/T>.

NO : Intermittent malfunction (Refer to GROUP
00 –How to Use Troubleshooting/Inspection
Service Points [P.00-5](#)).

Inspection Procedure 4: The Engine Warning Lamp Remains Illuminating and Never Goes Out

Engine warning lamp (check engine lamp) circuit

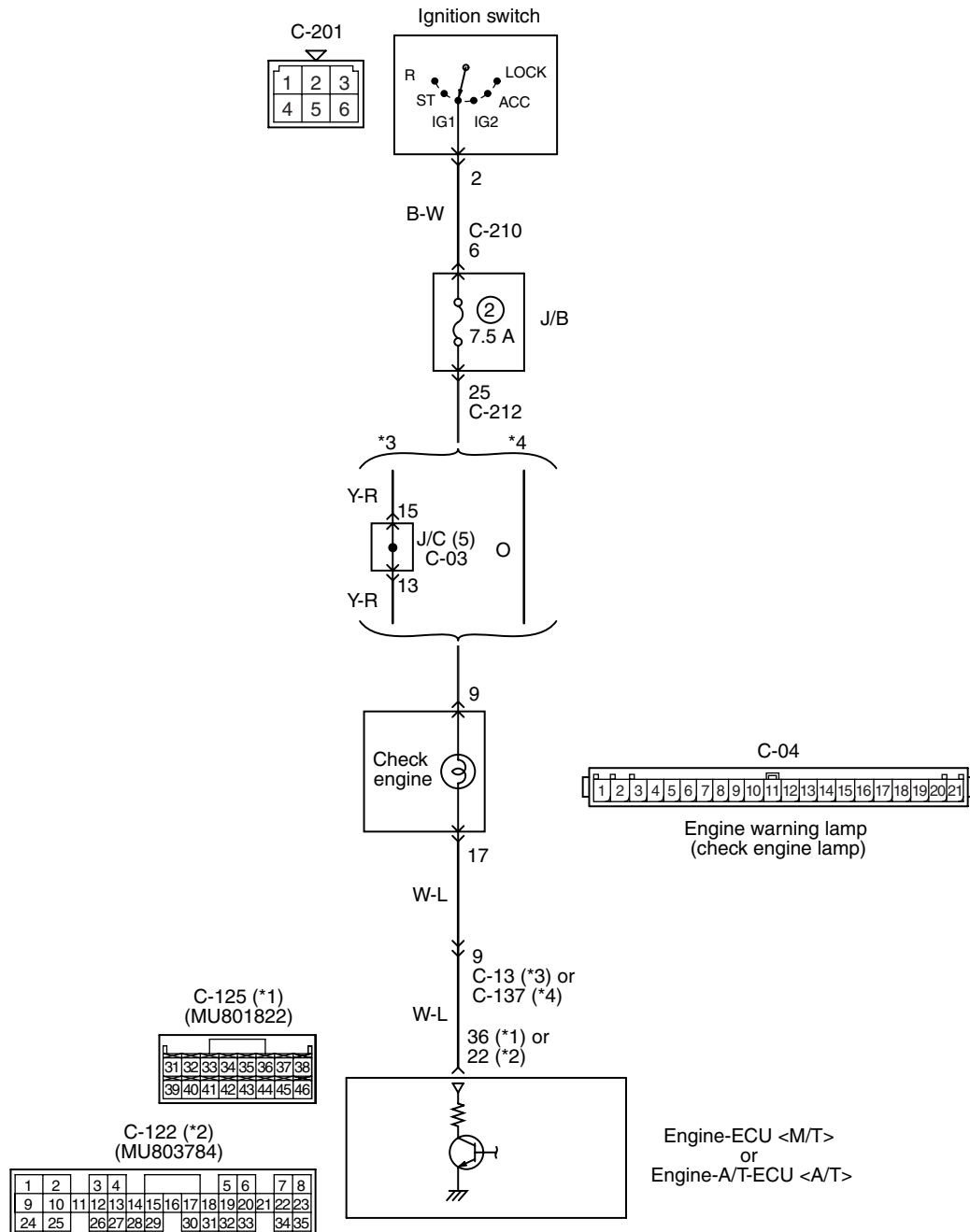

NOTE

- *1: M/T
- *2: A/T
- *3: L.H. drive vehicles
- *4: R.H. drive vehicles

Wire colour code

B: Black LG: Light green G: Green L: Blue W: White Y: Yellow SB: Sky blue BR: Brown O: Orange GR: Gray
R: Red P: Pink V: Violet

OPERATION

- Battery voltage is applied to engine warning lamp (terminal No. 9) from ignition switch.
- Engine-ECU (terminal No. 36) <M/T> or engine-A/T-ECU (terminal No. 22) <A/T> makes power transistor in unit be in "ON" position, and that makes currents go on engine warning lamp (terminal No. 17).

COMMENT ON TROUBLE SYMPTOM

- Engine-ECU <M/T> or engine-A/T-ECU <A/T> has detected failed sensor or failed actuator. Or failure is possibly caused by short circuit or other faults.

PROBABLE CAUSE

- Short circuit in engine warning lamp circuit.
- Failed engine-ECU <M/T>
- Failed engine-A/T-ECU <A/T>

DIAGNOSIS PROCEDURE

NOTE:

- *1: L.H. drive vehicles
- *2: R.H. drive vehicles

STEP 1. M.U.T.-II/III diagnosis code

Q: Diagnosis code set?

YES : Inspection chart for diagnosis code (Refer to P.13A-17.)

NO : Go to Step 2 .

STEP 2. Connector check: C-125 engine-ECU <M/T> connector or C-122 engine-A/T-ECU <A/T> connector

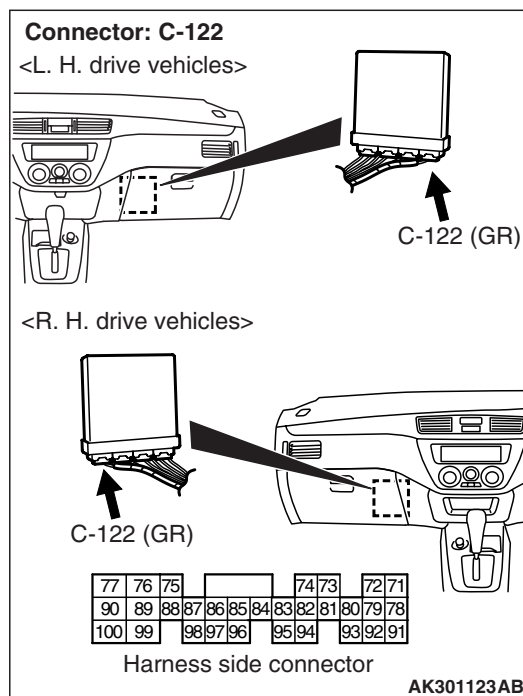
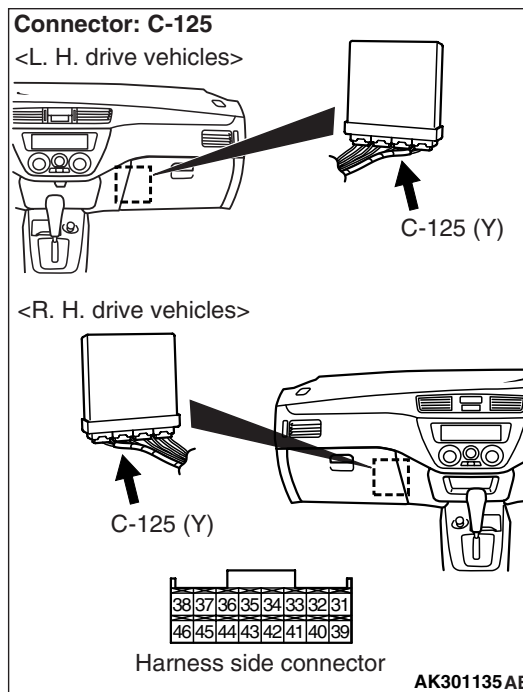

Q: Is the check result normal?

YES : Go to Step 3 .

NO : Repair or replace.

STEP 3. Perform voltage measurement at C-125 engine-ECU <M/T> or C-122 engine-A/T-ECU <A/T> connector.

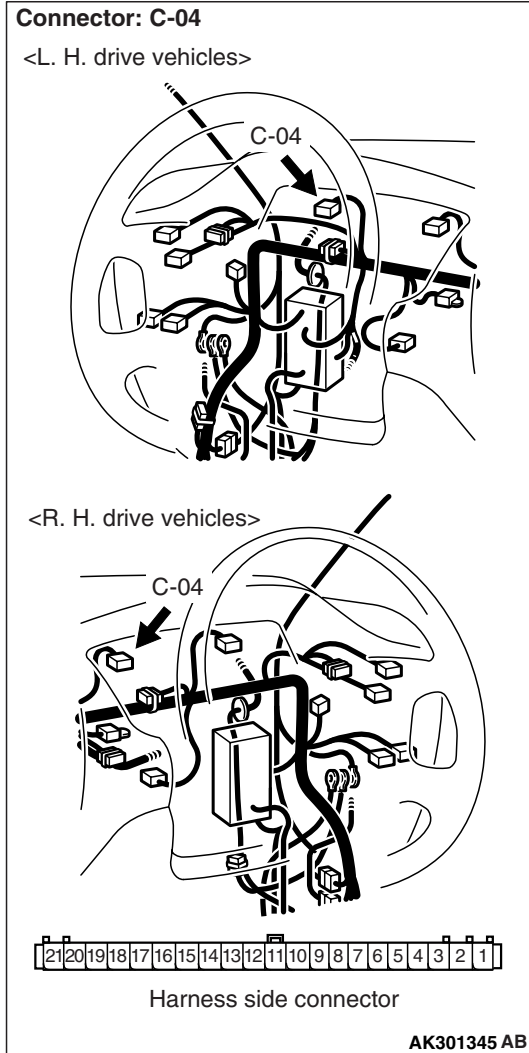
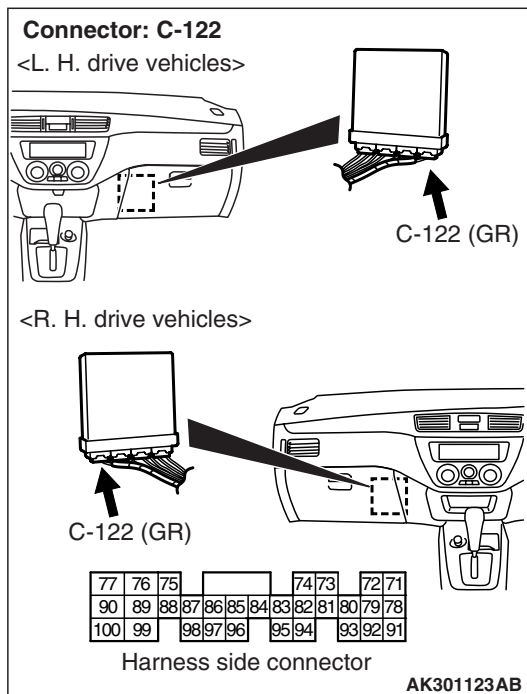
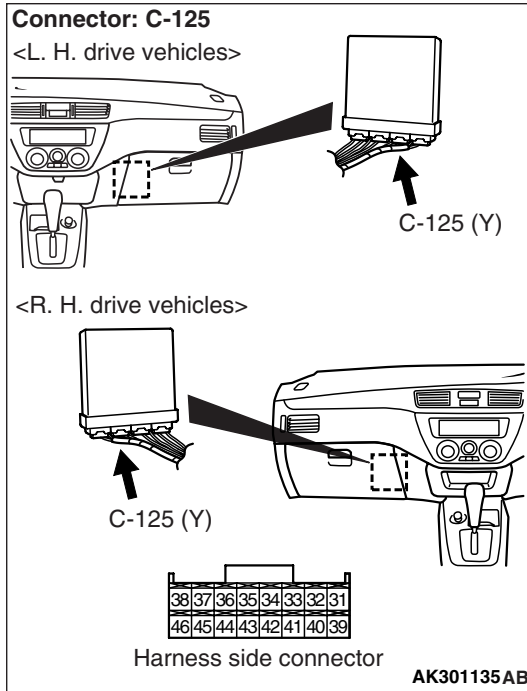

- Disconnect connector, and measure at the harness side.
- Ignition switch: ON
- Voltage between terminal No. 36 <M/T> or terminal No. 22 <A/T> and earth.

OK: System voltage

Q: Is the check result normal?

YES : Go to Step 4 .

NO : Check intermediate connector C-13*¹ or

C-137*², and repair if necessary. If intermediate connector is normal, check and repair harness between C-04 (terminal No. 17) combination meter connector and C-125 (terminal No. 36) engine-ECU <M/T> connector or C-122 (terminal No. 22) engine-A/T-ECU <A/T> connector.

- Check output line for short circuit.

STEP 4. Check the trouble symptoms.**Q: Does trouble symptom persist?**

YES : Replace engine-ECU <M/T> or
engine-A/T-ECU <A/T>.

NO : Intermittent malfunction (Refer to GROUP
00 –How to Use Troubleshooting/Inspection
Service Points [P.00-5](#)).

Inspection Procedure 5: Starting Impossible (No Initial Combustion) <M/T>

Starting impossible (no initial combustion)

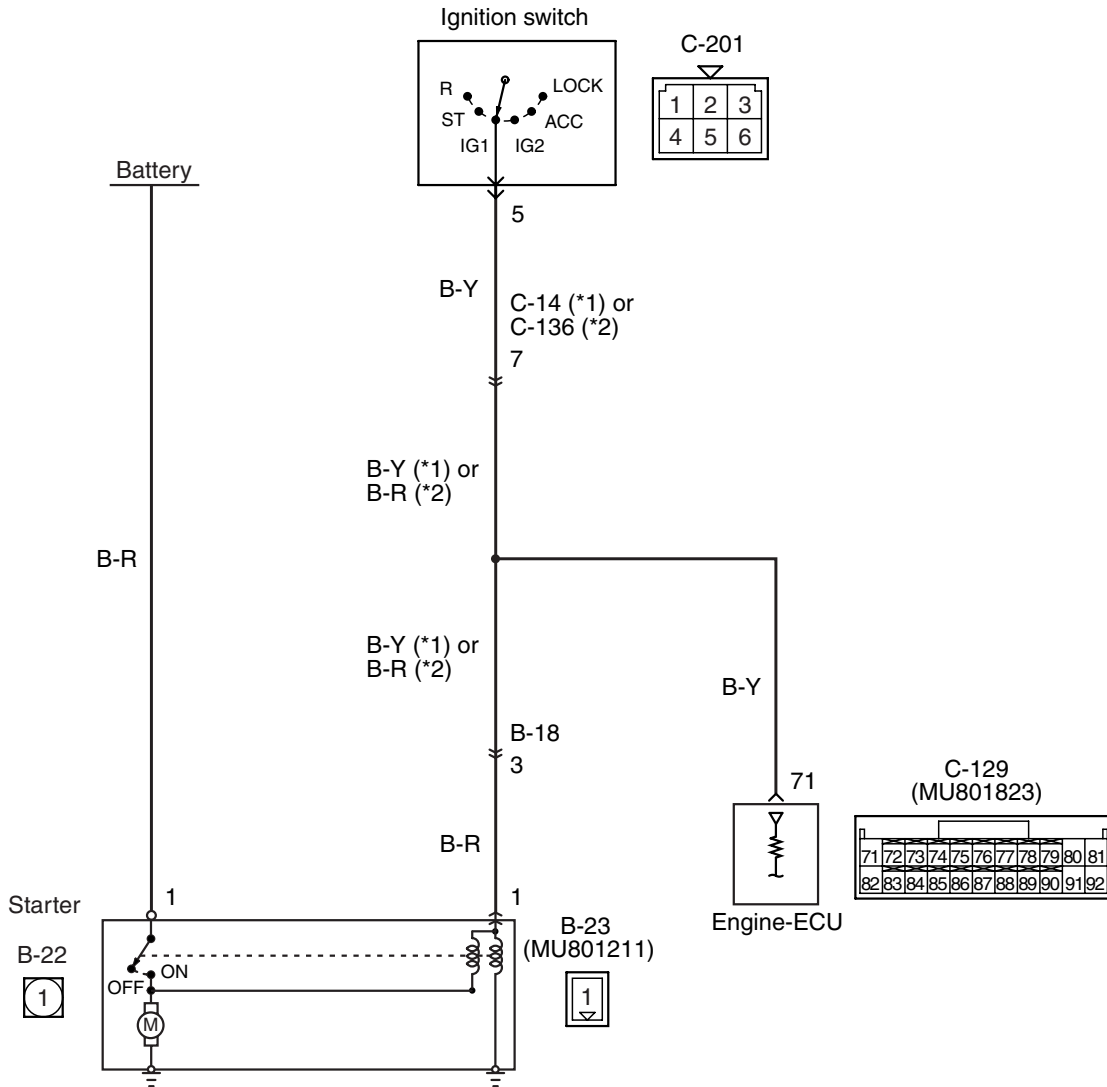

NOTE

- *1: L.H. drive vehicles
- *2: R.H. drive vehicles

Wire colour code

B: Black LG: Light green G: Green L: Blue W: White Y: Yellow SB: Sky blue BR: Brown O: Orange GR: Gray
R: Red P: Pink V: Violet

AK301347AB

OPERATION

- If the ignition switch is turned to "START" position, battery voltage is applied to starter (terminal No.1).
- If the ignition switch is turned to "START" position, battery voltage is applied to engine-ECU (terminal No.71) from ignition switch. Because of this, engine-ECU detects that the engine is cranked.

COMMENT ON TROUBLE SYMPTOM

- Failure is possibly caused by failed starter itself or failed related circuit.

PROBABLE CAUSE

- Failed battery
- Failed starter motor
- Open/short circuit in starter associated circuit or loose connector contact

DIAGNOSIS PROCEDURE**NOTE:**

- *1: L.H. drive vehicles
- *2: R.H. drive vehicles

STEP 1. Check battery voltage.

- Measure battery voltage at cranking.

OK: 8 V or higher

Q: Is the check result normal?

YES : Go to Step 2 .

NO : Check battery (Refer to GROUP 54A – Battery –On-vehicle Service –Battery Test P.54A-5).

STEP 2. M.U.T.-II/III data list

- Refer to data list reference table P.13A-376.
 - Item 18: Cranking signal

OK:

ON (Ignition switch: ST)

OFF (Ignition switch: ON)

Q: Is the check result normal?

YES : Go to Step 8 .

NO : Go to Step 3 .

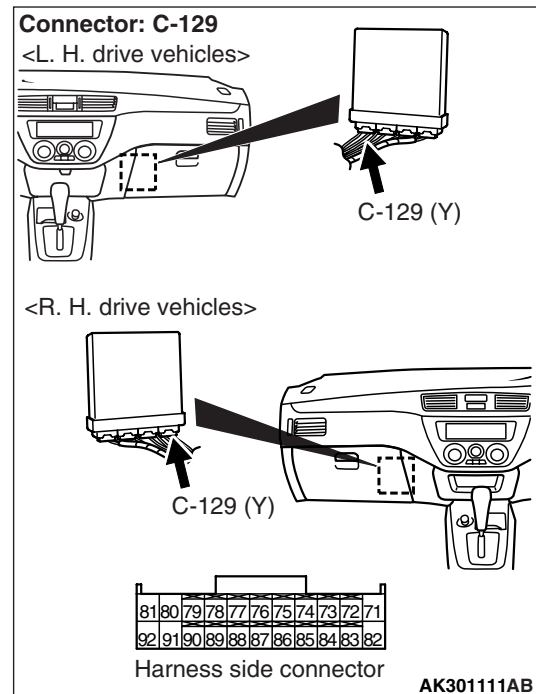
STEP 3. Connector check: C-129 engine-ECU connector**Q: Is the check result normal?**

YES : Go to Step 4 .

NO : Repair or replace.

STEP 4. Perform voltage measurement at C-129 engine-ECU connector.

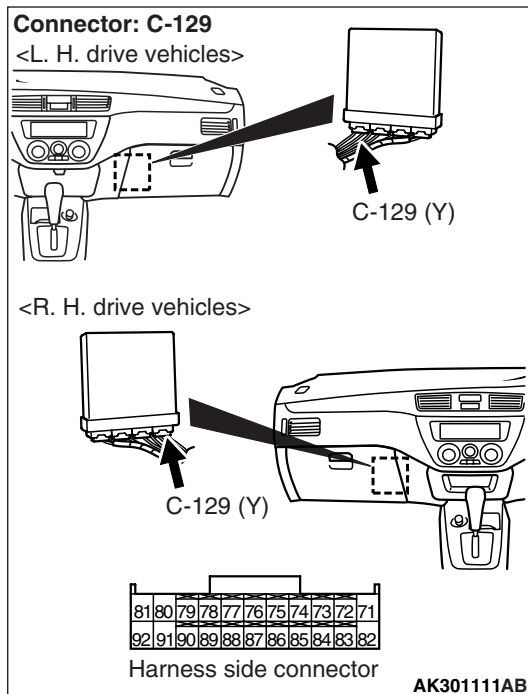

- Disconnect connector, and measure at the harness side.
- Ignition switch: ST
- Voltage between terminal No. 71 and earth.

OK: System voltage

Q: Is the check result normal?

- YES :** Go to Step 7 .
NO : Go to Step 5 .

STEP 5. Connector check: C-201 ignition switch connector



Q: Is the check result normal?

- YES :** Go to Step 6 .
NO : Repair or replace.

STEP 6. Check ignition switch.

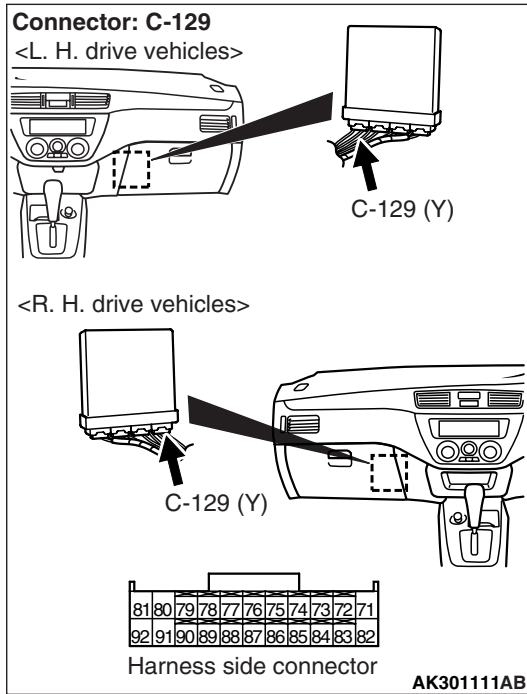

Q: Is the check result normal?

YES : Check intermediate connectors C-14*¹, C-136*², and repair if necessary. If intermediate connector are normal, check and repair harness between C-129 (terminal No. 71) inhibitor switch connector and C-201 (terminal No. 5) ignition switch connector.

- Check power supply line for open/short circuit.

NO : Replace ignition switch.



- Check ignition switch (Refer to GROUP 54A – Ignition Switch –Ignition Switch P.54A-31).

STEP 7. Connector check: C-201 ignition switch connector and B-23 starter connector



STEP 8. Check connector: B-23 starter connector

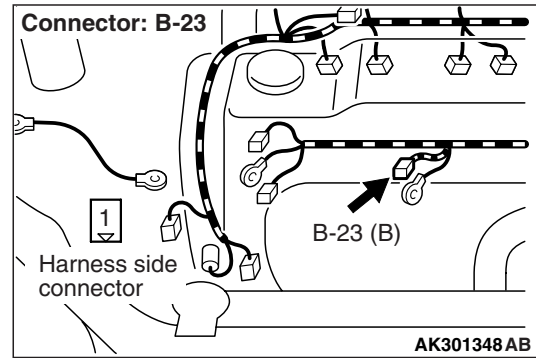

Q: Is the check result normal?

YES : Go to Step 9 .

NO : Repair or replace.

STEP 9. Perform voltage measurement at B-23 starter connector.

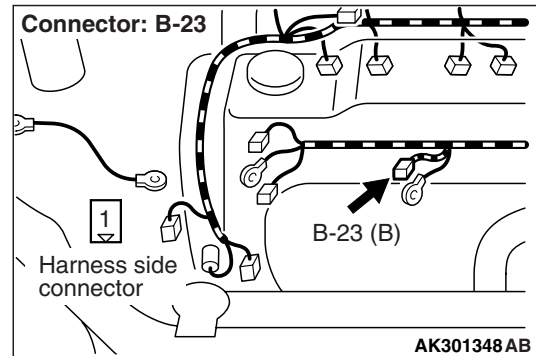

- Disconnect connector, and measure at the harness side.
- Ignition switch: ST
- Voltage between terminal No. 1 and earth.

OK: System voltage

Q: Is the check result normal?

YES : Go to Step 11 .

NO : Go to Step 10 .

Q: Is the check result normal?

YES : Check intermediate connectors C-14*¹, C-136*² and B-18, and repair if necessary. If intermediate connectors are normal, check and repair harness between C-201 (terminal No. 5) ignition switch connector and B-23 (terminal No. 1) starter connector.

- Check output line for short circuit.

NO : Repair or replace.

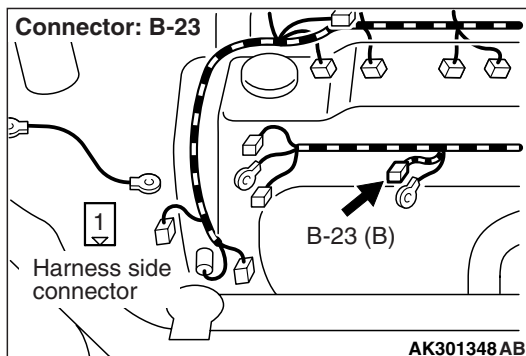
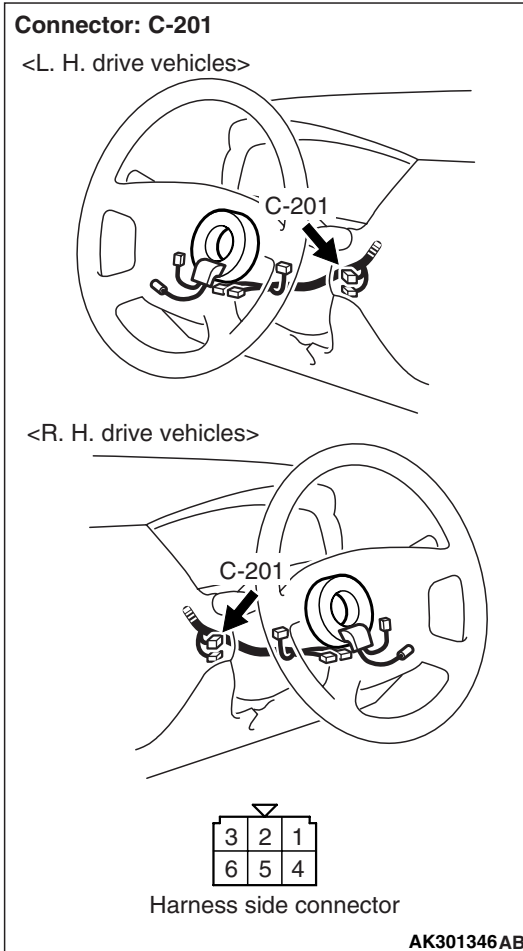
STEP 10. Connector check: C-201 ignition switch connector**Q: Is the check result normal?**

YES : Check intermediate connectors C-14*¹, C-136*² and B-18, and repair if necessary. If intermediate connectors are normal, check and repair harness between C-201 (terminal No. 5) ignition switch connector and B-23 (terminal No. 1) starter connector.

- Check output line for open circuit and damage.

NO : Repair or replace.

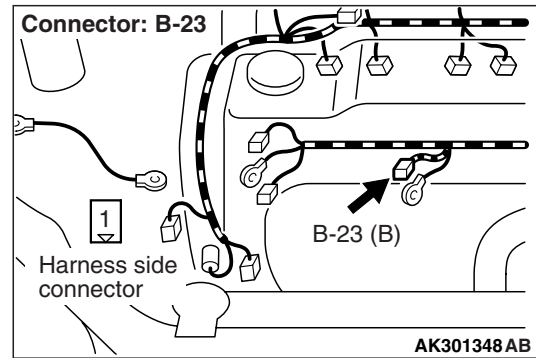
STEP 11. Connector check: B-23 starter connector**Q: Is the check result normal?**

YES : Go to Step 12 .

NO : Repair or replace.

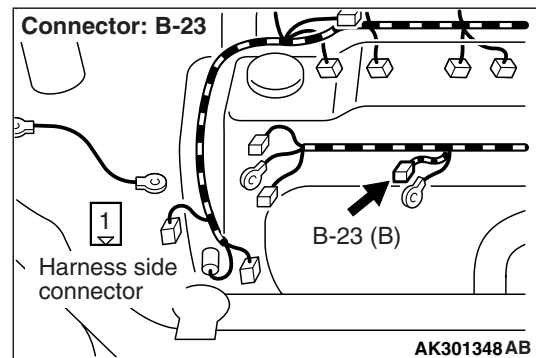
STEP 12. Perform voltage measurement at B-23 starter connector.

- Disconnect connector, and measure at the harness side.
- Voltage between terminal No. 1 and earth.

OK: System voltage

Q: Is the check result normal?

YES : Go to Step 13 .

NO : Check and repair harness between B-22 (terminal No. 1) starter connector and battery.

- Check power supply line for open/short circuit.

STEP 13. Check harness between C-201 (terminal No. 5) ignition switch connector and B-23 (terminal No. 1) starter connector.



STEP 14. Check harness between B-22 (terminal No. 1) starter connector and battery.

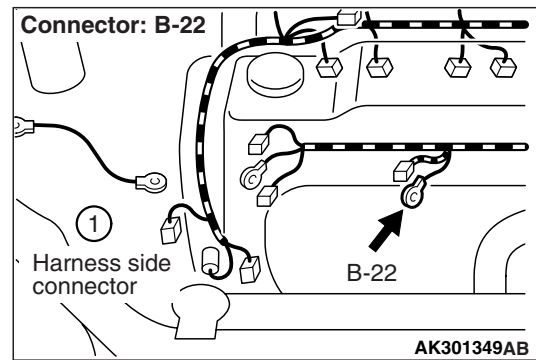

- Check power supply line for damage.

Q: Is the check result normal?

YES : Replace starter.

NO : Repair.

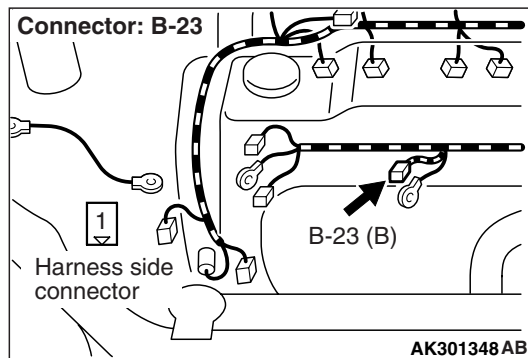

NOTE: Before checking harness, check intermediate connectors B-18 and C-14*¹, C-136*², and repair if necessary.

- Check output line for damage.

Q: Is the check result normal?

YES : Go to Step 14 .

NO : Repair.

Inspection Procedure 5: Starting Impossible (No Initial Combustion) <A/T>

Starting impossible (no initial combustion)

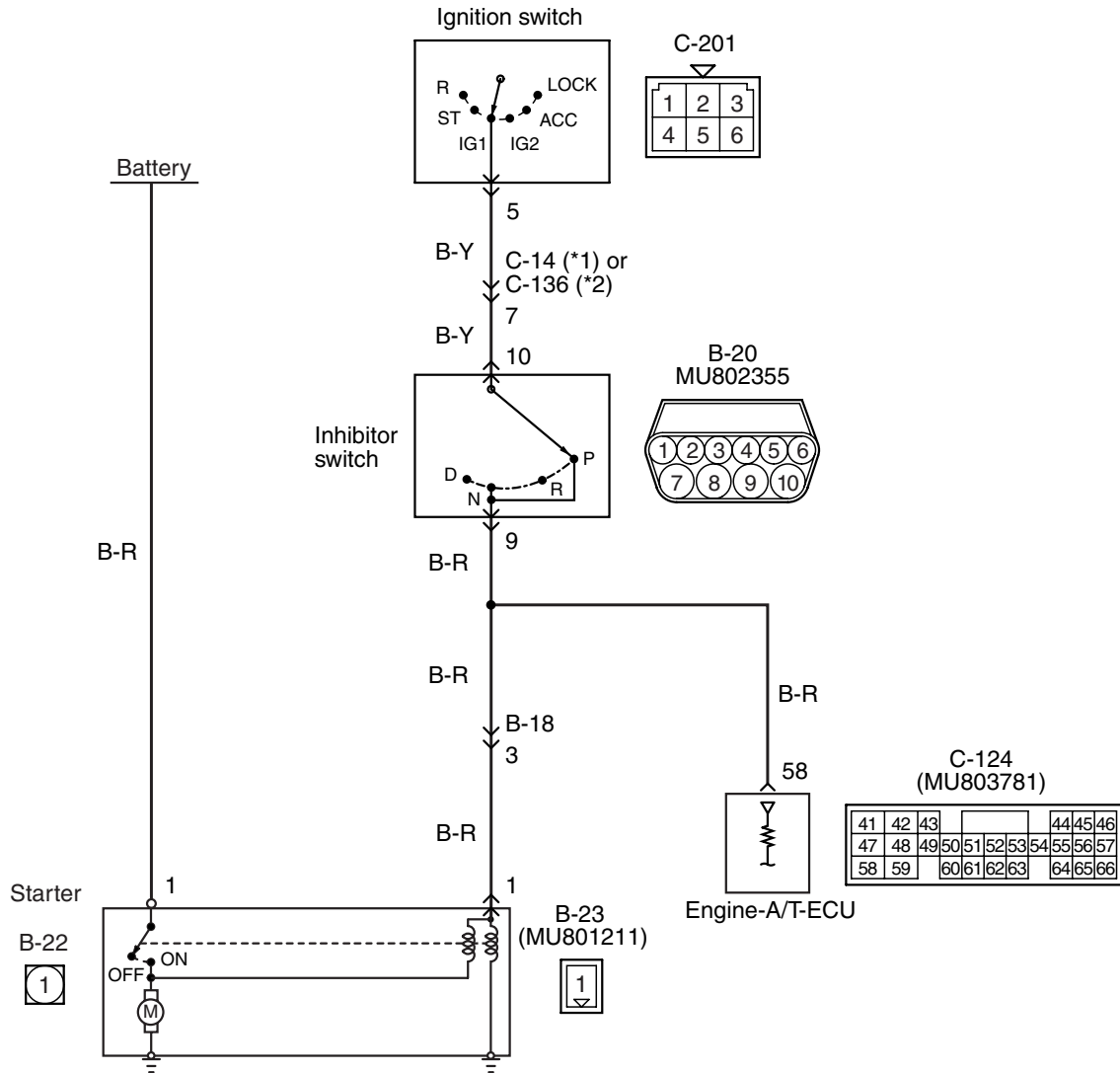

NOTE

- *1: L.H. drive vehicles
- *2: R.H. drive vehicles

Wire colour code

B: Black LG: Light green G: Green L: Blue W: White Y: Yellow SB: Sky blue BR: Brown O: Orange GR: Gray
R: Red P: Pink V: Violet

AK401361AB

OPERATION

- If the ignition switch is turned to "START" position, battery voltage is applied to starter (terminal No.1).
- If the ignition switch is turned to "START" position, battery voltage is applied to engine-A/T-ECU (terminal No.58) from ignition switch. Because of this, engine-A/T-ECU detects that the engine is cranked.

COMMENT ON TROUBLE SYMPTOM

- Failure is possibly caused by failed starter itself or failed related circuit.

PROBABLE CAUSE

- Failed battery
- Failed starter motor
- Open/short circuit in starter associated circuit or loose connector contact
- Failed inhibitor switch

DIAGNOSIS PROCEDURE

NOTE:

- *1: L.H. drive vehicles
- *2: R.H. drive vehicles

STEP 1. Check battery voltage.

- Measure battery voltage at cranking.

OK: 8 V or higher

Q: Is the check result normal?

YES : Go to Step 2 .

NO : Check battery (Refer to GROUP 54A – Battery –On-vehicle Service –Battery Test P.54A-5).

STEP 2. M.U.T.-II/III data list

- Refer to data list reference table P.13A-376.
 - a. Item 18: Cranking signal

OK:

ON (Ignition switch: ST)

OFF (Ignition switch: ON)

Q: Is the check result normal?

YES : Go to Step 12 .

NO : Go to Step 3 .

STEP 3. Connector check: B-20 inhibitor switch connector

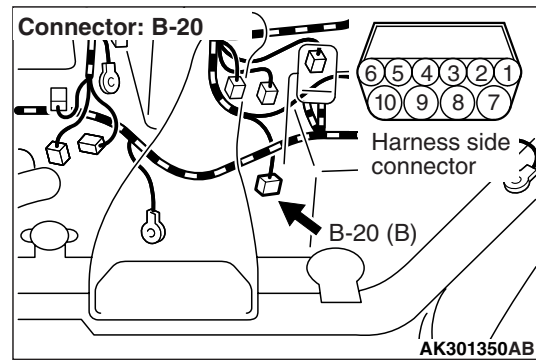

Q: Is the check result normal?

YES : Go to Step 4 .

NO : Repair or replace.

STEP 4. Perform voltage measurement at B-20 inhibitor switch connector.

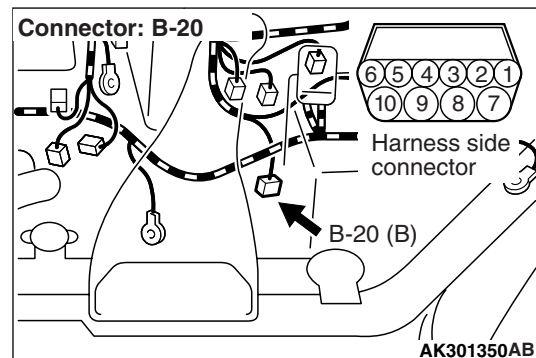

- Disconnect connector, and measure at the harness side.
- Ignition switch: ST
- Voltage between terminal No. 10 and earth.

OK: System voltage

Q: Is the check result normal?

YES : Go to Step 7 .

NO : Go to Step 5 .

STEP 5. Connector check: C-201 ignition switch connector

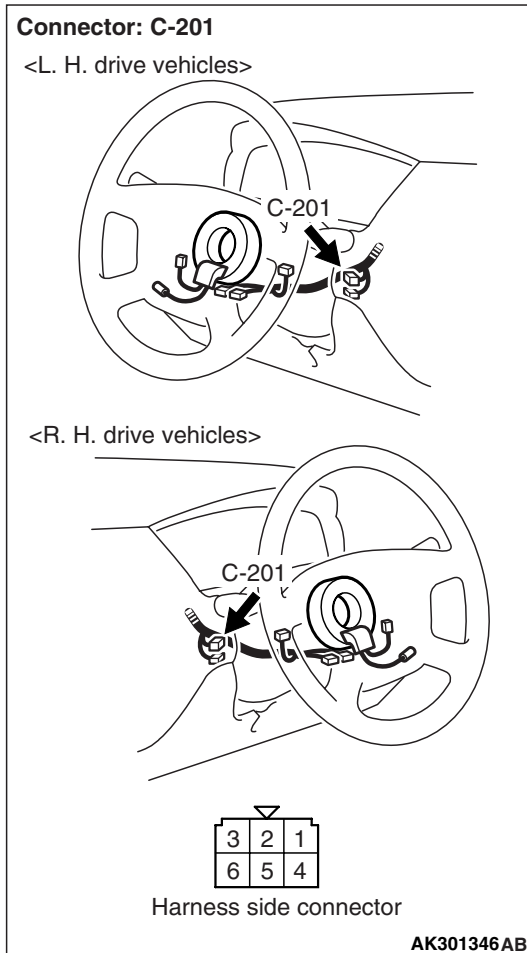

Q: Is the check result normal?
YES : Go to Step 6 .
NO : Repair or replace.

STEP 6. Check ignition switch.

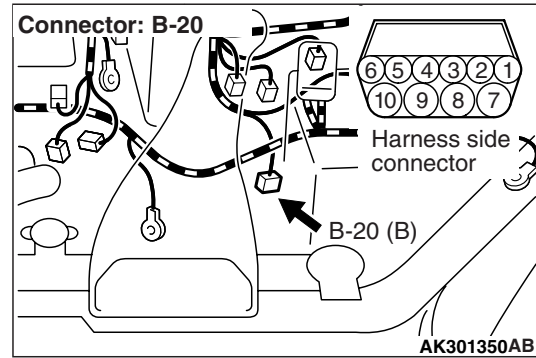

- Check ignition switch (Refer to GROUP 54A – Ignition Switch – Ignition Switch P.54A-31).

Q: Is the check result normal?

YES : Check intermediate connector C-14*¹, C-136*², and repair if necessary. If intermediate connector is normal, check and repair harness between B-20 (terminal No. 10) inhibitor switch connector and C-201 (terminal No. 5) ignition switch connector.

- Check power supply line for open/short circuit.

NO : Replace ignition switch.

STEP 7. Check inhibitor switch.

- Check inhibitor switch (Refer to GROUP 23A – On-vehicle Service –Essential Service P.23A-132).

Q: Is the check result normal?

- YES :** Go to Step 8 .
- NO :** Replace inhibitor switch.

STEP 8. Connector check: B-18 intermediate connector

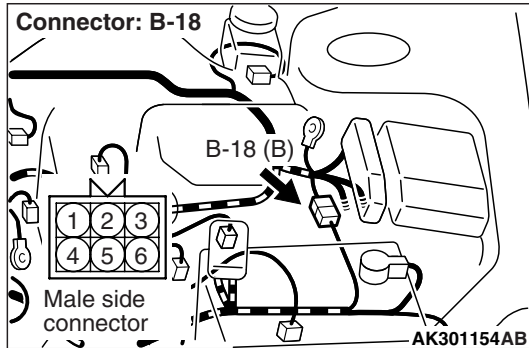

Q: Is the check result normal?

- YES :** Go to Step 9 .
- NO :** Repair or replace.

STEP 9. Check harness between B-20 (terminal No. 9) inhibitor switch connector and B-18 (terminal No. 3) intermediate connector.

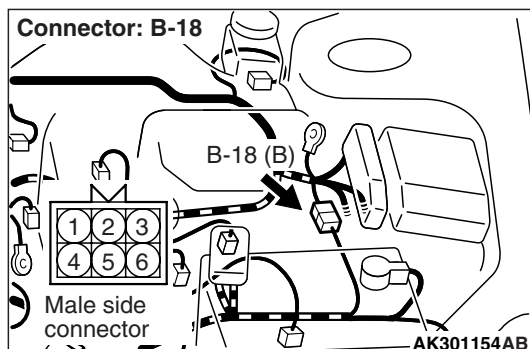
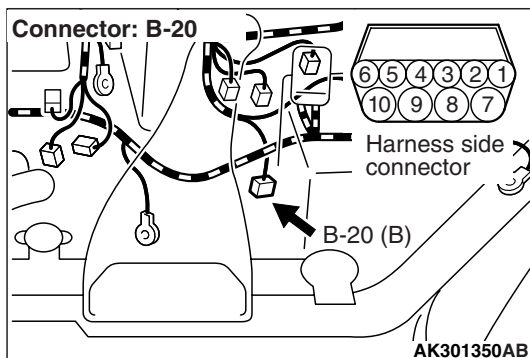

- Check output line for open/short circuit.

Q: Is the check result normal?

- YES :** Go to Step 10 .
- NO :** Repair.

STEP 10. Check harness between B-18 (terminal No. 3) intermediate connector and B-23 (terminal No. 1) starter connector.

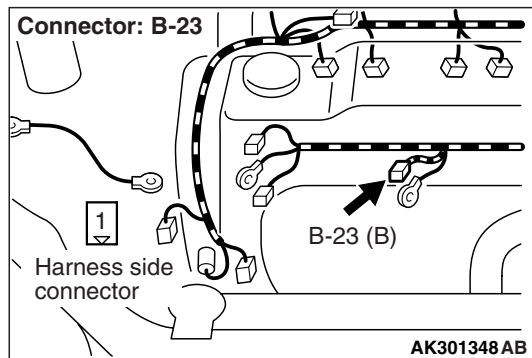
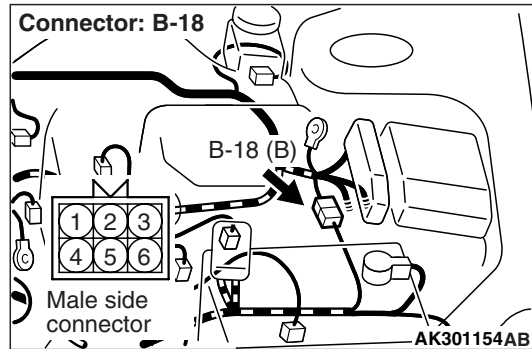

- Check output line for open/short circuit.

Q: Is the check result normal?

- YES :** Go to Step 11 .
- NO :** Repair.

STEP 11. Connector check: C-124 engine-A/T-ECU connector

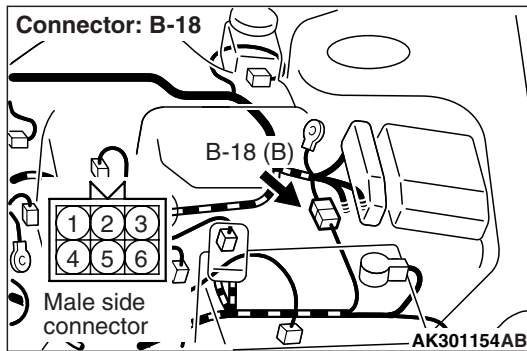
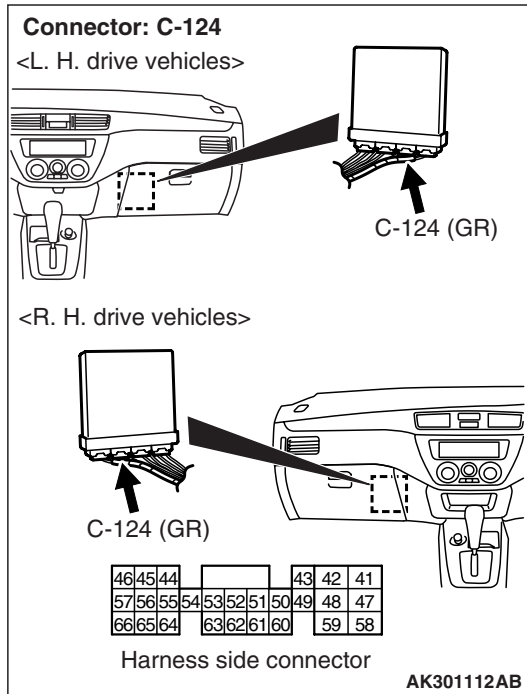

Q: Is the check result normal?

YES : Check and repair harness between B-18 (terminal No. 3) intermediate connector and C-124 (terminal No. 58) engine-A/T-ECU connector.

- Check output line for open/short circuit.

NO : Repair or replace.

STEP 12. Connector check: B-23 starter connector

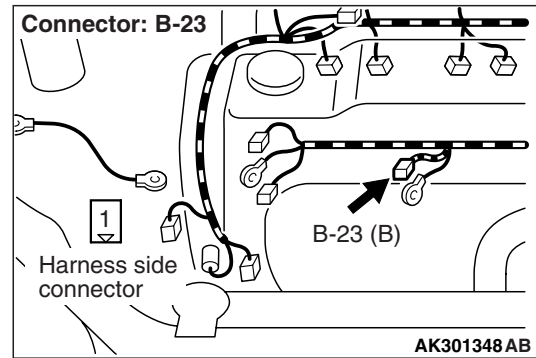

Q: Is the check result normal?

YES : Go to Step 13 .

NO : Repair or replace.

STEP 13. Perform voltage measurement at B-23 starter connector.

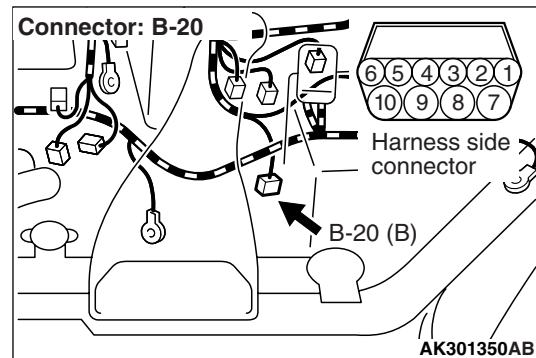
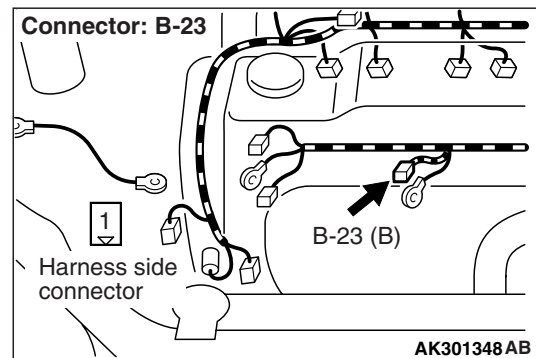

- Disconnect connector, and measure at the harness side.
- Ignition switch: ST
- Voltage between terminal No. 1 and earth.

OK:

System voltage (Selector lever position: P or N)

1 V or less (Selector lever position: Other than P or N)

Q: Is the check result normal?

YES : Go to Step 14 .

NO : Check intermediate connector B-18, and repair if necessary. If intermediate connector is normal, check and repair harness between B-20 (terminal No. 9) inhibitor switch connector and B-23 (terminal No. 1) starter connector.

- Check output line for open/short circuit.

STEP 14. Connector check: B-22 starter connector

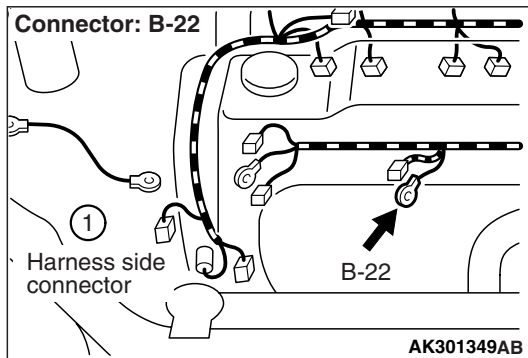

Q: Is the check result normal?

YES : Go to Step 15 .

NO : Repair or replace.

STEP 15. Perform voltage measurement at B-22 starter connector.

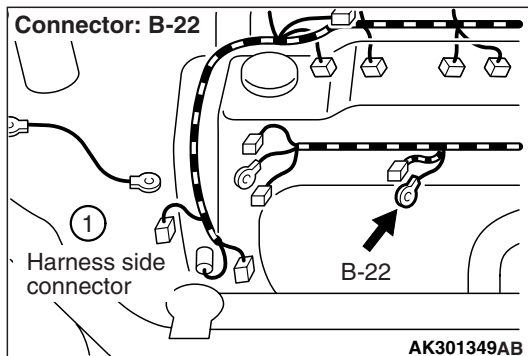

- Disconnect connector, and measure at the harness side.
- Voltage between terminal No. 1 and earth.

OK: System voltage

Q: Is the check result normal?

YES : Go to Step 16 .

NO : Check and repair harness between B-22 (terminal No. 1) starter connector and battery.

- Check power supply line for open/short circuit.

STEP 16. Connector check: C-201 ignition switch connector, B-23 starter connector

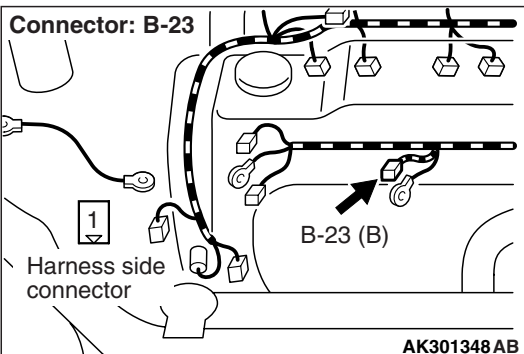
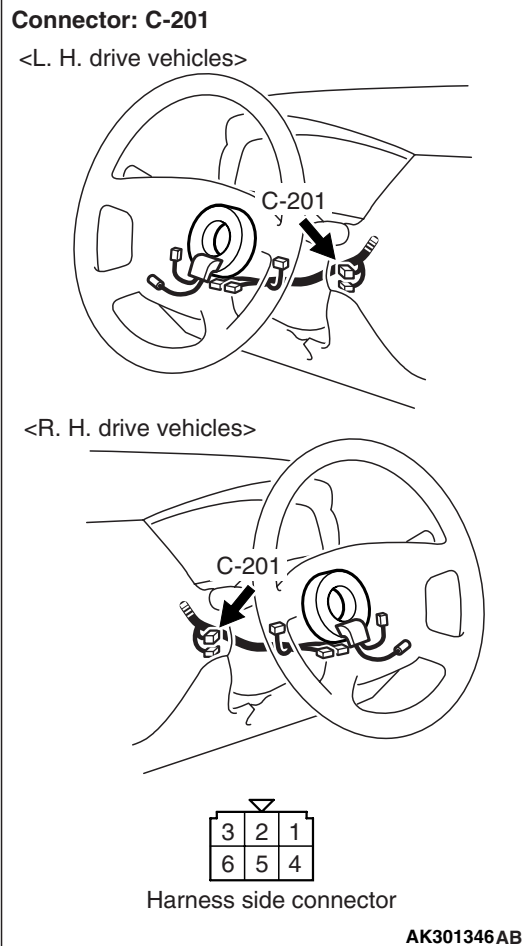

Q: Is the check result normal?

YES : Go to Step 17 .

NO : Repair or replace.

STEP 17. Check harness between C-201 (terminal No. 5) ignition switch connector and B-20 (terminal No. 10) inhibitor switch connector.

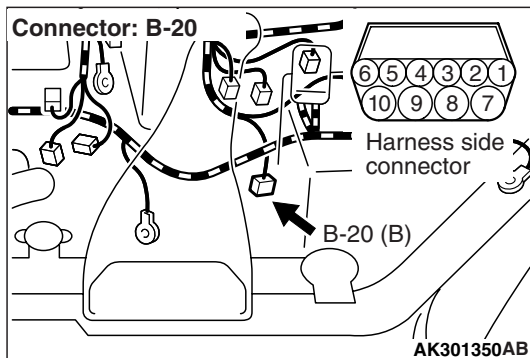
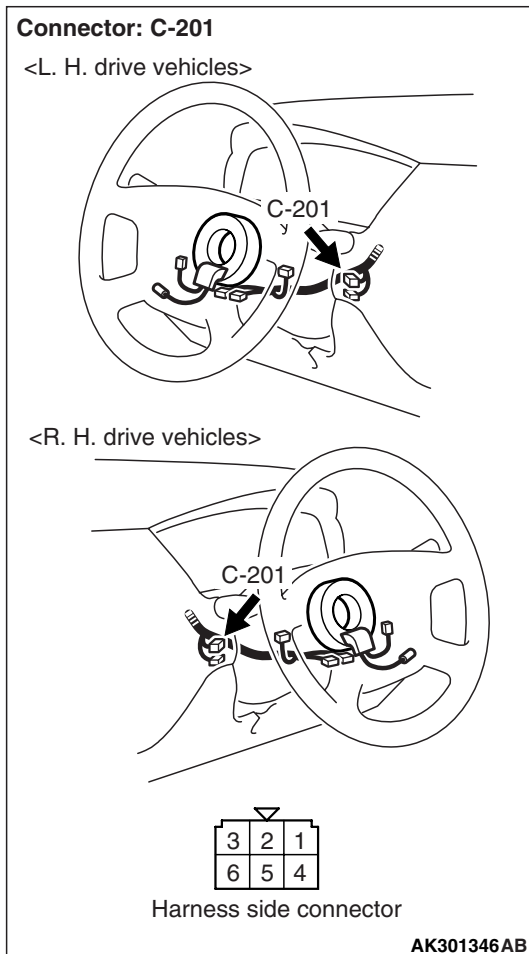

NOTE: Before checking harness, check intermediate connector C-14*¹, C-136*², and repair if necessary.

- Check power supply line for damage.

Q: Is the check result normal?

YES : Go to Step 18 .

NO : Repair.

STEP 18. Check harness between B-20 (terminal No. 9) inhibitor switch connector and B-23 (terminal No. 1) starter connector.

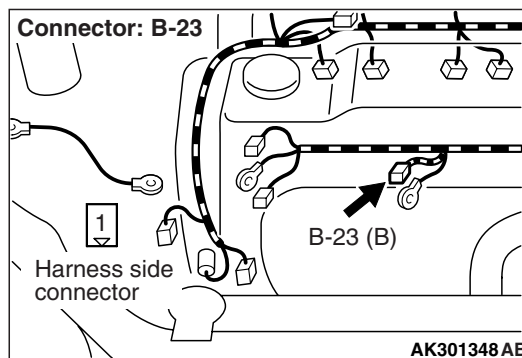
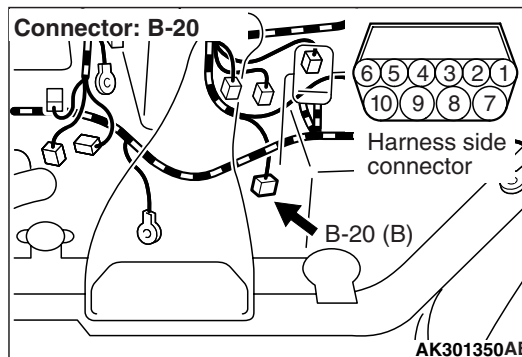

NOTE: Before checking harness, check intermediate connector B-18, and repair if necessary.

- Check output line for damage.

Q: Is the check result normal?

YES : Go to Step 19 .

NO : Repair.

STEP 19. Check harness between B-22 (terminal No. 1) starter connector and battery.

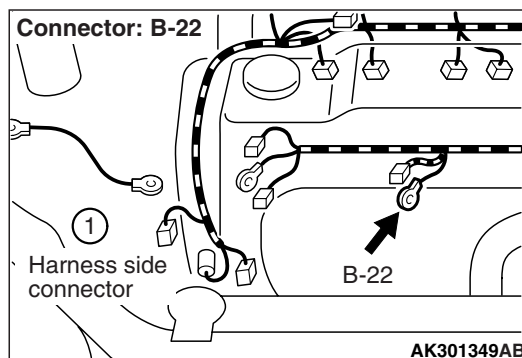

- Check power supply line for damage.

Q: Is the check result normal?

YES : Replace starter.

NO : Repair.

Inspection Procedure 6: Starting Impossible (Starter Operative but No Initial Combustion) <M/T>

OPERATION

- Refer to Inspection procedure, Ignition circuit system <L. H. drive vehicles> [P.13A-361](#) or Ignition circuit system <R. H. drive vehicles> [P.13A-368](#)

COMMENT ON TROUBLE SYMPTOM

- Failure is possibly caused by failed ignition circuit, failed fuel feed or other faults.

PROBABLE CAUSE

- Failed battery
- Timing belt broken
- Failed idle speed control
- Throttle valve fouled around
- Failed ignition system
- Failed fuel system
- Failed immobilizer system
- Failed engine-ECU

DIAGNOSIS PROCEDURE

NOTE:

*1: L.H. drive vehicles

*2: R.H. drive vehicles

STEP 1. Check battery voltage.

- Measure battery voltage at cranking.

OK: 8 V or higher

Q: Is the check result normal?

YES : Go to Step 2 .

NO : Check battery (Refer to GROUP 54A – Battery –On-vehicle Service –Battery test [P.54A-5](#)).

STEP 2. Check engine warning lamp for burnt out bulb.

Q: Is the check result normal?

YES : Go to Step 3 .

NO : Check engine-ECU power supply, engine control relay and ignition switch IG-1 system (Refer to Inspection Procedure 23 [P.13A-321](#)).

STEP 3. M.U.T.-II/III diagnosis code

Q: Diagnosis code set?

YES : Inspection chart for diagnosis codes (Refer to [P.13A-17](#))

NO : Go to Step 4 .

STEP 4. M.U.T.-II/III actuator test

- Refer to actuator test reference table [P.13A-383](#).

a. Item 07: Fuel pump

OK: Operating sound of fuel pump can be heard.

Q: Is the check result normal?

YES : Go to Step 5 .

NO : Check fuel pump system (Refer to Inspection Procedure 24 [P.13A-334](#))

STEP 5. Check timing belt for breakage.

- Engine: Cranking

OK: Camshaft rotates.

Q: Is the check result normal?

YES : Go to Step 6 .

NO : Replace timing belt.

STEP 6. Check the engine start ability.

- With depressing the accelerator pedal slightly, and start the engine.

Q: Is the start ability good?

YES : Go to Step 7 .

NO : Go to Step 8 .

STEP 7. Check idling speed control for operating sound.

- Check idle speed control servo for operating sound (Refer to [P.13A-408](#)).

Q: Is the check result normal?

YES : Clean throttle body (throttle valve portion) (Refer to [P.13A-398](#)).

NO : Check idle speed control servo system (Refer to code No. P0505 [P.13A-206](#)).

STEP 8. M.U.T.-II/III data list

- Refer to data list reference table [P.13A-376](#).
a. Item 18: Cranking signal

OK:

ON (Ignition switch: ST)

OFF (Ignition switch: ON)

Q: Is the check result normal?

YES : Go to Step 10 .

NO : Go to Step 9 .

STEP 9. Connector check: C-129 engine-ECU connector

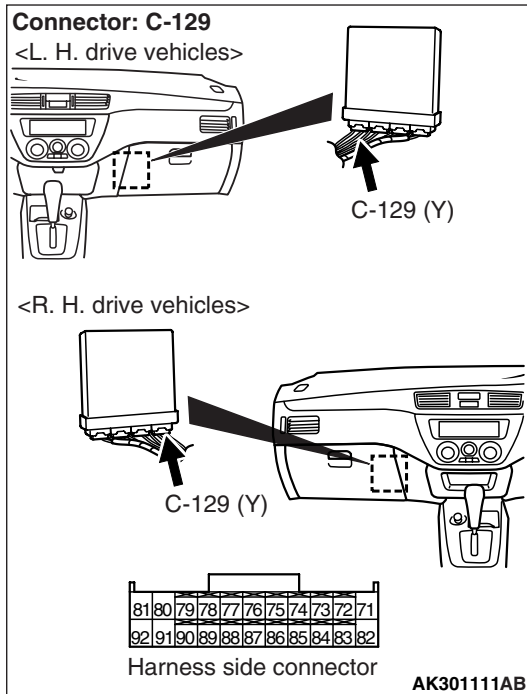

Q: Is the check result normal?

YES : Check intermediate connectors C-14*¹, C-136*², and repair if necessary. If intermediate connectors are normal, check and repair harness between C-201 (terminal No. 5) ignition switch connector and C-129 (terminal No. 71) engine-ECU connector.

- Check output line for open/short circuit.

NO : Repair or replace.

STEP 10. M.U.T.-II/III data list

- Refer to data list reference table [P.13A-376](#).
 - Item 22: Crank angle sensor

Q: Is the check result normal?

YES : Go to Step 11 .

NO : Check crank angle sensor system (Refer to Code No. P0335 [P.13A-161](#)).

STEP 11. Check injector for operating sound.

- Check injector for operating sound (Refer to [P.13A-407](#)).

Q: Can operating sound be heard?

YES : Go to Step 12 .

NO : Check the injector system of the defective cylinder.

(Refer to Code No. P0201: No. 1 injector system [P.13A-115](#).)

(Refer to Code No. P0202: No. 2 injector system [P.13A-121](#).)

(Refer to Code No. P0203: No. 3 injector system [P.13A-127](#).)

(Refer to Code No. P0204: No. 4 injector system [P.13A-133](#).)

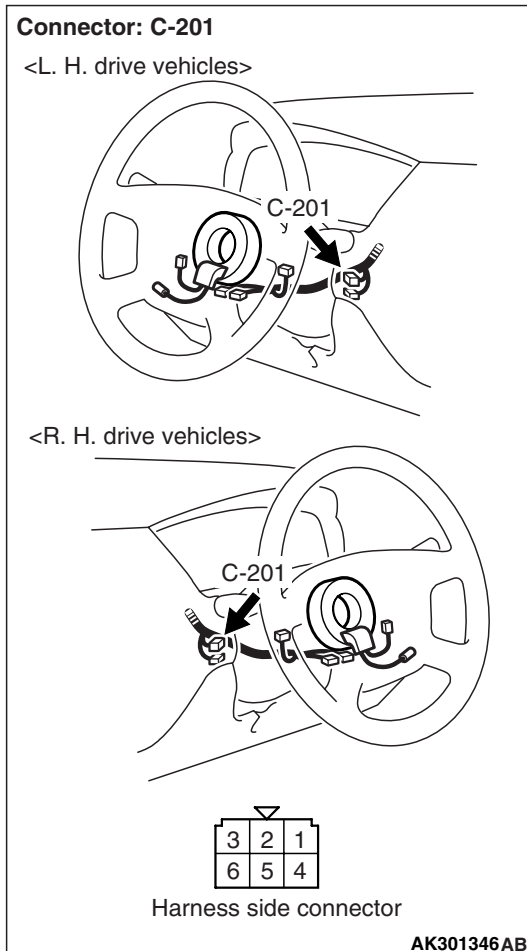

STEP 12. Check ignition coil spark.

Connector: C-201

<L. H. drive vehicles>

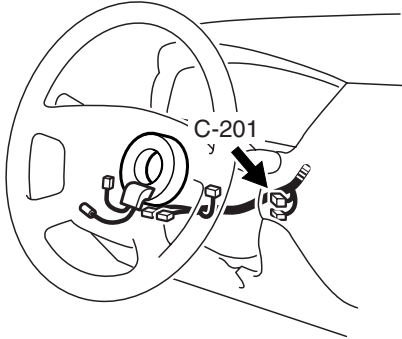

<R. H. drive vehicles>

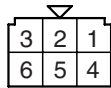
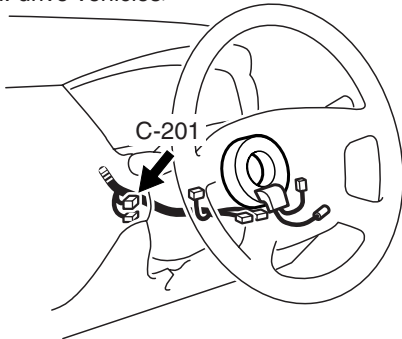

Harness side connector

AK301346AB

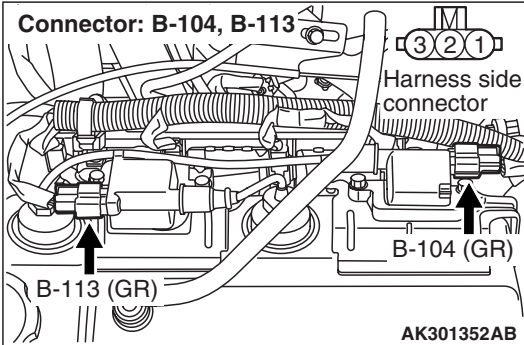

AK301352AB

Q: Is the check result normal?

YES : Go to Step 13 .

NO : Check ignition circuit system (Refer to Inspection procedure 28 <L.H.drive vehicles> P.13A-361 or Inspection procedure 29<R.H.drive vehicles> P.13A-368).

STEP 13. Replace engine-ECU.

- After replacing the engine-ECU, re-check the trouble symptoms.

Q: Does trouble symptom persist?

YES : Check for foreign matters (water, kerosene, etc.) in fuel and replace if necessary.

NO : Check end.

Inspection Procedure 6: Starting Impossible (Starter Operative but No Initial Combustion) <A/T>**OPERATION**

- Refer to Inspection procedure, Ignition circuit system <L. H. drive vehicles> [P.13A-361](#) or Ignition circuit system <R. H. drive vehicles> [P.13A-368](#)

COMMENT ON TROUBLE SYMPTOM

- Failure is possibly caused by failed ignition circuit, failed fuel feed or other faults.

PROBABLE CAUSE

- Failed battery
- Timing belt broken
- Failed idle speed control
- Throttle valve fouled around
- Failed ignition system
- Failed fuel system
- Failed immobilizer system
- Failed engine-A/T-ECU

DIAGNOSIS PROCEDURE**STEP 1. Check battery voltage.**

- Measure battery voltage at cranking.

OK: 8 V or higher

Q: Is the check result normal?

YES : Go to STEP 2 .

NO : Check battery (Refer to GROUP 54A – Battery –On-vehicle Service –Battery test [P.54A-5](#)).

STEP 2. Check engine warning lamp for burnt out bulb.**Q: Is the check result normal?**

YES : Go to Step 3 .

NO : Check engine-A/T-ECU power supply, engine control relay and ignition switch IG-1 system (Refer to Inspection Procedure 23 [P.13A-321](#)).

STEP 3. M.U.T.-II/III diagnosis code**Q: Diagnosis code set?**

YES : Inspection chart for diagnosis codes (Refer to [P.13A-17](#))

NO : Go to Step 4 .

STEP 4. M.U.T.-II/III actuator test

- Refer to actuator test reference table [P.13A-383](#).

a. Item 07: Fuel pump

OK: Operating sound of fuel pump can be heard.

Q: Is the check result normal?

YES : Go to Step 5 .

NO : Check fuel pump system (Refer to Inspection Procedure 24 [P.13A-334](#))

STEP 5. Check timing belt for breakage.

- Engine: Cranking

OK: Camshaft rotates.

Q: Is the check result normal?

YES : Go to Step 6 .

NO : Replace timing belt.

STEP 6. Check the engine start ability.

- With depressing the accelerator pedal slightly, and start the engine.

Q: Is the start ability good?

YES : Go to Step 7 .

NO : Go to Step 8 .

STEP 7. Check idling speed control for operating sound.

- Check idle speed control servo for operating sound (Refer to [P.13A-408](#)).

Q: Is the check result normal?

YES : Clean throttle body (throttle valve portion) (Refer to [P.13A-398](#)).

NO : Check idle speed control servo system (Refer to code No. P0505 [P.13A-206](#)).

STEP 8. M.U.T.-II/III data list

- Refer to data list reference table [P.13A-376](#).
 - Item 18: Cranking signal

OK:

ON (Ignition switch: ST)

OFF (Ignition switch: ON)

Q: Is the check result normal?

YES : Go to Step 10 .

NO : Go to Step 9 .

STEP 9. Connector check: C-124 engine-A/T-ECU connector

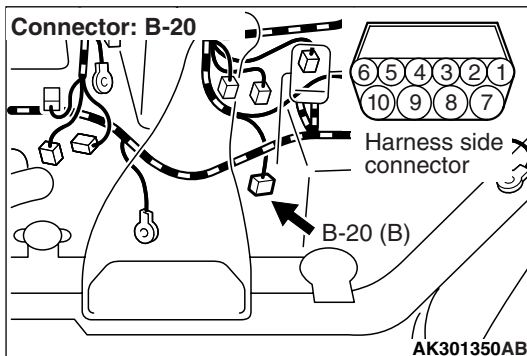
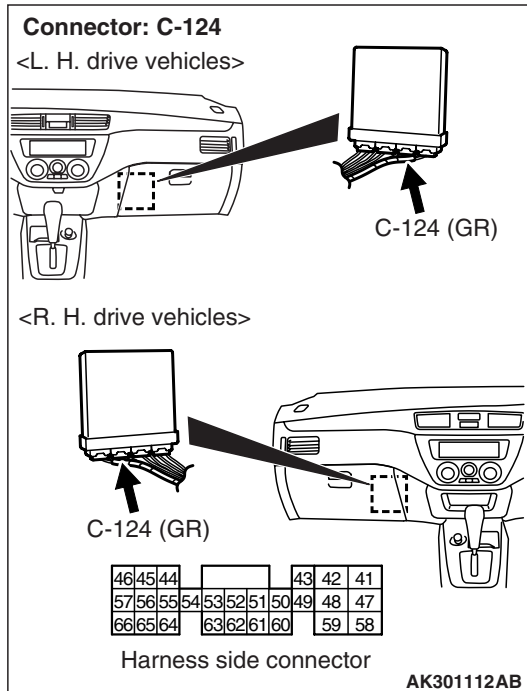

Q: Is the check result normal?

YES : Check and repair harness between B-20 (terminal No. 9) inhibitor switch connector and C-124 (terminal No. 58) engine-A/T-ECU connector.

- Check output line for open/short circuit.

NO : Repair or replace.

STEP 10. M.U.T.-II/III data list

- Refer to data list reference table [P.13A-376](#).
 - Item 22: Crank angle sensor

Q: Is the check result normal?

YES : Go to Step 11 .

NO : Check crank angle sensor system (Refer to Code No. P0335 [P.13A-161](#)).

STEP 11. Check injector for operating sound.

- Check injector for operating sound (Refer to [P.13A-407](#)).

Q: Can operating sound be heard?

YES : Go to Step 12 .

NO : Check the injector system of the defective cylinder.

(Refer to Code No. P0201: No. 1 injector system [P.13A-115](#).)

(Refer to Code No. P0202: No. 2 injector system [P.13A-121](#).)

(Refer to Code No. P0203: No. 3 injector system [P.13A-127](#).)

(Refer to Code No. P0204: No. 4 injector system [P.13A-133](#).)

STEP 12. Check ignition coil spark.

Connector: C-201

<L. H. drive vehicles>

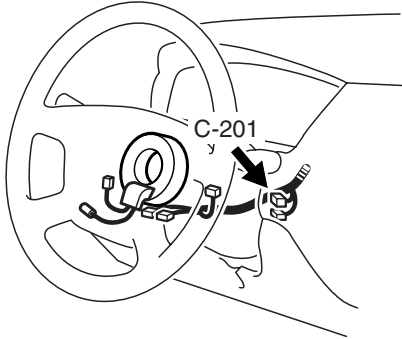

<R. H. drive vehicles>

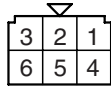
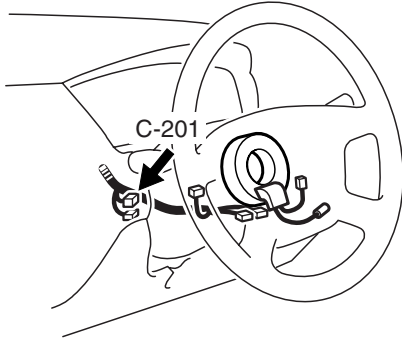

Harness side connector

AK301346AB

Q: Is the check result normal?

YES : Go to Step 13 .

NO : Check ignition circuit system (Refer to Inspection procedure 28 <L.H.drive vehicles>[P.13A-361](#) or Inspection procedure 29<R.H.drive vehicles>[P.13A-368](#)).

STEP 13. Replace engine-A/T-ECU.

- After replacing the engine-A/T-ECU, re-check the trouble symptoms.

Q: Does trouble symptom persist?

YES : Check for foreign matters (water, kerosene, etc.) in fuel and replace if necessary.

NO : Check end.

Connector: B-104, B-113

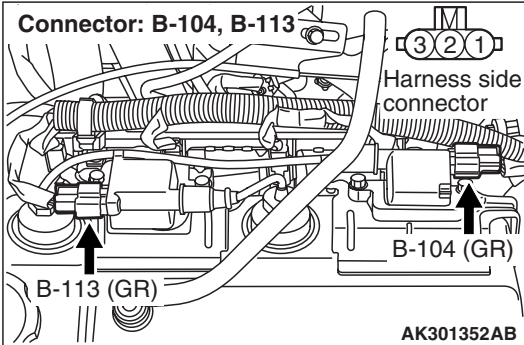

AK301352AB

Inspection Procedure 7: Starting Impossible (Initial Combustion But No Complete Combustion), Improper Starting (Long Time to Start)

COMMENT ON TROUBLE SYMPTOM

- Failure is possibly caused by poor ignition, incorrect air-fuel ratio at cranking, improper fuel pressure or other faults.

PROBABLE CAUSE

- Failed battery
- Failed ignition system
- Failed fuel system
- Failed Air-fuel ratio control
- Failed idle speed control system
- Failed intake system
- Failed exhaust gas cleaning system
- Throttle valve fouled around
- Timing belt not in place
- Compression pressure improper
- Failed engine-ECU <M/T>
- Failed engine-A/T-ECU <A/T>

DIAGNOSIS PROCEDURE

STEP 1. Check battery condition.

Q: Have the battery terminal been disconnected?

YES : After warm-up engine, idle for about 10 minutes.

NO : Go to Step 2 .

STEP 2. Check battery voltage.

- Measure battery voltage at cranking.

OK: 8 V or higher

Q: Is the check result normal?

YES : Go to Step 3 .

NO : Check battery (Refer to GROUP 54A – Battery –On-vehicle Service –Battery Test P.54A-5).

STEP 3. M.U.T.-II/III diagnosis code

Q: Diagnosis code set?

YES : Inspection chart for diagnosis codes (Refer to P.13A-17)

NO : Go to Step 4 .

STEP 4. M.U.T.-II/III data list

- Refer to data list reference table P.13A-376.
 - a. Item 13: Intake air temperature sensor
 - b. Item 21: Engine coolant temperature sensor
 - c. Item 32: Manifold absolute pressure sensor

Q: Are the check results normal?

YES : Go to Step 5 .

NO : Perform the diagnosis code classified check procedure for the sensor that has shown an abnormal data value (Refer to Inspection Chart for Diagnosis Codes P.13A-17).

STEP 5. Check start ability.

- With depressing the accelerator pedal slightly, and start the engine.

Q: Is the start ability good?

YES : Go to Step 6 .

NO : Go to Step 7 .

STEP 6. Check idle speed control servo for operating sound.

- Check idle speed control servo for operating sound (Refer to P.13A-408).

Q: Is the check result normal?

YES : Clean throttle body (throttle valve portion) (Refer to P.13A-398).

NO : Check idle speed control servo system (Refer to Code No. P0505 P.13A-206).

STEP 7. M.U.T.-II/III actuator test

- Refer to actuator test reference table P.13A-383.
 - a. Item 07: Fuel pump

OK: Operating sound of fuel pump can be heard.

Q: Is the check result normal?

YES : Go to Step 8 .

NO : Check fuel pump system (Refer to Inspection Procedure 24 P.13A-334).

STEP 8. Check air intake from intake hose and inlet manifold.

Q: Is the check result normal?

YES : Go to Step 9 .

NO : Repair.

STEP 9. Check injector for operating sound.

- Check injector for operating sound at engine cranking (Refer to P.13A-407).

Q: Can operating sound be heard?

YES : Go to Step 10 .

NO : Check the injector system of the defective cylinder.

(Refer to Code No. P0201: No.1 injector system P.13A-115.)

(Refer to Code No. P0202: No.2 injector system P.13A-121.)

(Refer to Code No. P0203: No.3 injector system P.13A-127.)

(Refer to Code No. P0204: No.4 injector system P.13A-133.)

STEP 10. Check timing marks of timing belt.

Q: Is the check result normal?

YES : Go to Step 11 .

NO : Align timing marks.

STEP 11. Perform voltage measurement at C-123 engine-ECU <M/T> or C-124 engine-A/T-ECU <A/T> connector.

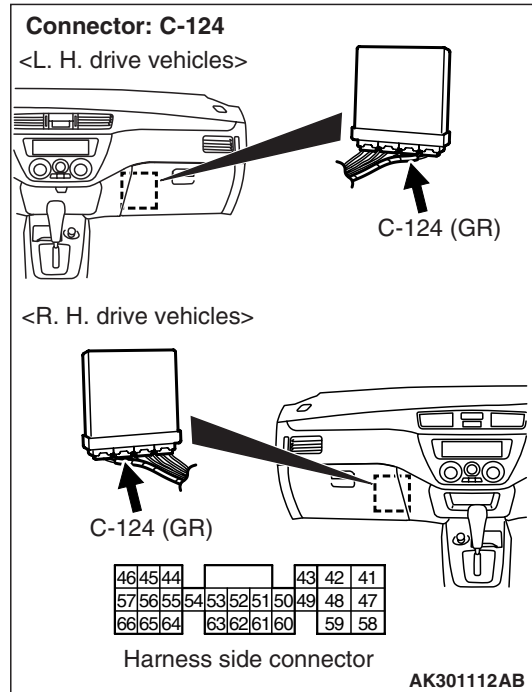
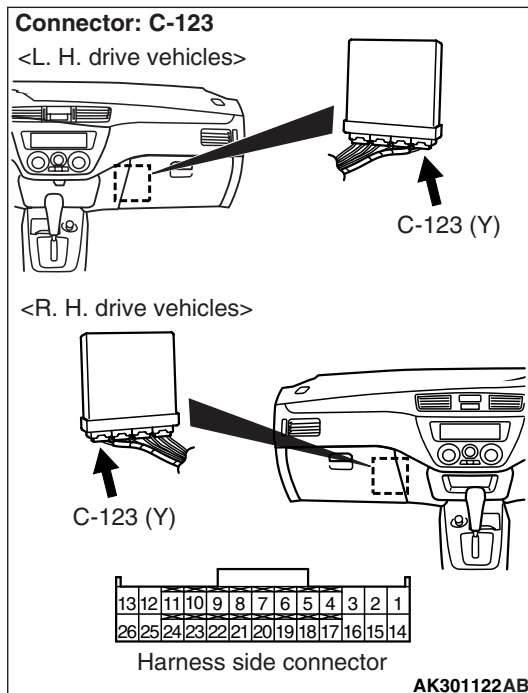

- Measure engine-ECU <M/T> or engine-A/T-ECU <A/T> terminal voltage.
- Ignition switch: ON
- Voltage between terminal No. 13 <M/T> or terminal No. 48 <A/T> and earth, also between terminal No. 26 <M/T> or terminal No. 43 <A/T> and earth.

OK: 0.5 V or less

Q: Is the check result normal?

YES : Go to Step 13 .

NO : Go to Step 12 .

STEP 12. Connector check: C-123 engine-ECU <M/T> or C-124 engine-A/T-ECU <A/T> connector

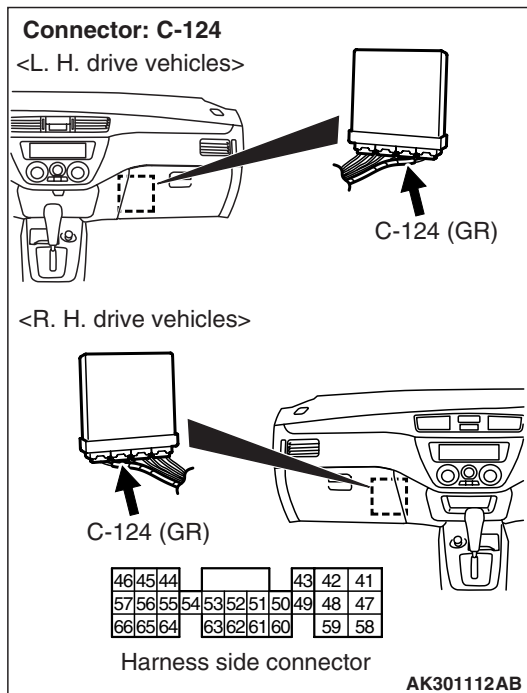
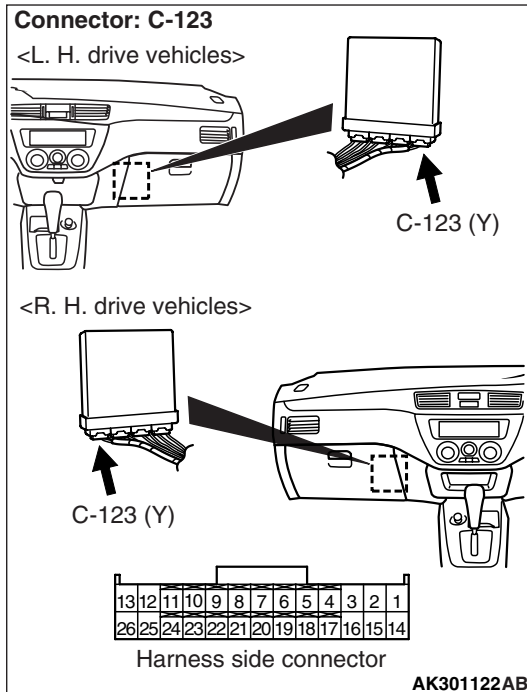

Q: Is the check result normal?

YES : Check and repair harness between C-123 (terminal No. 13 and No. 26) engine-ECU <M/T> or C-124 (terminal No. 43 and No. 48) engine-A/T-ECU <A/T> connector and body earth.

- Check earthing line for open circuit and damage.

NO : Repair or replace.

STEP 13. Connector check: B-104 and B-113 ignition coil connectors

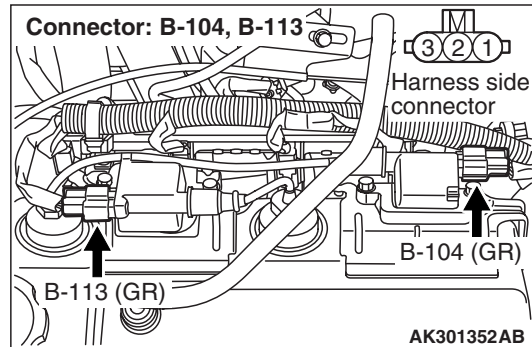

Q: Is the check result normal?

YES : Go to Step 14 .

NO : Repair or replace.

STEP 14. Check ignition secondary voltage waveform using an oscilloscope.

- Check ignition secondary voltage waveform (Refer to GROUP 16 –Ignition System –On-vehicle Service P.16-32).

Q: Is the check result normal?

YES : Go to Step 19 .

NO : Go to Step 15 .

STEP 15. Check spark plug.

- Check spark plug (Refer to GROUP 16 –Ignition System –On-vehicle Service P.16-31).

Q: Is the check result normal?

YES : Go to Step 16 .

NO : Replace spark plug.

STEP 16. Check resistive cord itself.

- Check resistive cord itself (Refer to GROUP 16 – Ignition System –On-vehicle Service P.16-30).

Q: Is the check result normal?

YES : Go to Step 17 .

NO : Replace resistive cord.

STEP 17. Check ignition coil itself.

- Check ignition coil itself (Refer to GROUP 16 – Ignition System –On-vehicle Service P.16-30).

Q: Is the check result normal?

YES : Go to Step 18 .

NO : Replace ignition coil.

STEP 18. Check harness between terminal No. 2 of each cylinder's ignition coil connector and vehicle body earth.

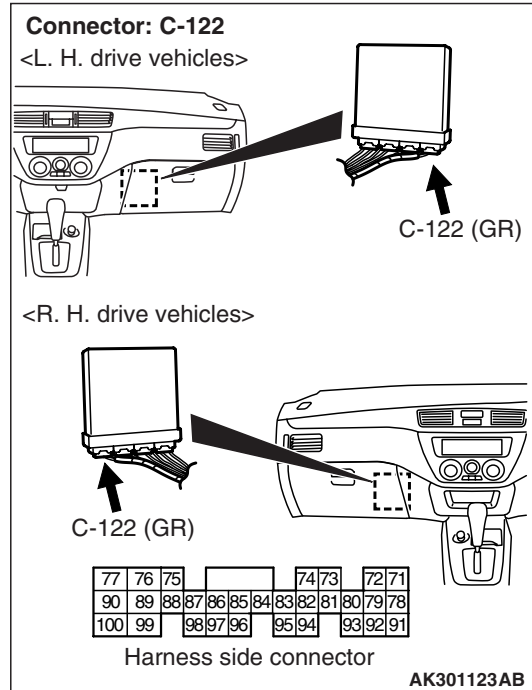
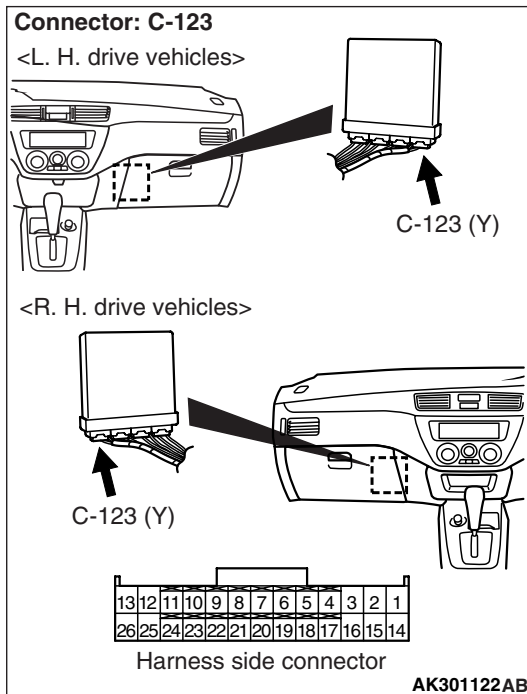
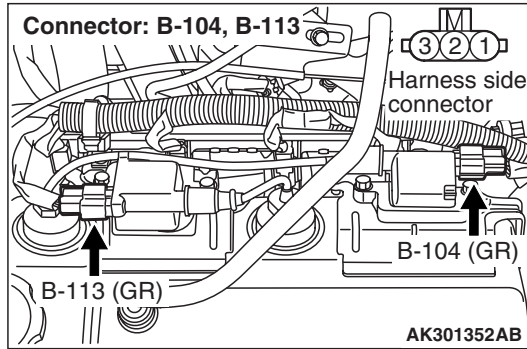

- Check earthing line for open circuit and damage.

Q: Is the check result normal?

YES : Check and repair harness between terminal No. 3 of each cylinder's ignition coil connector and C-123 engine-ECU <M/T> connector or C-122 engine-A/T-ECU <A/T> connector.

- Check signal line for open/short circuit and damage.

NO : Repair.

STEP 19. Check spray condition of injector.

- Check each injector for spray condition (Refer to P.13A-407).

Q: Is the check result normal?

YES : Go to Step 20 .

NO : Replace injector.

STEP 20. Check compression pressure.

- Check compression pressure (Refer to GROUP 11A –On-vehicle Service P.11A-12).

Q: Is the check result normal?

YES : Go to Step 21 .

NO : Repair.

STEP 21. Check EGR control solenoid valve itself.

- Check EGR control solenoid valve itself [Refer to GROUP 17 –Emission Control System – Exhaust Gas Recirculation (EGR) System [P.17-16](#)].

Q: Is the check result normal?

YES : Go to Step 22 .

NO : Replace EGR control solenoid valve.

STEP 22. Check EGR valve itself.

- Check EGR valve itself [Refer to GROUP 17 – Emission Control System – Exhaust Gas Recirculation (EGR) System [P.17-15](#)].

Q: Is the check result normal?

YES : Go to Step 23 .

NO : Replace EGR valve.

STEP 23. Replace engine-ECU.

- After replacing the engine-ECU <M/T> or engine-A/T-ECU <A/T>, re-check the trouble symptoms.

Q: Does trouble symptom persist?

YES : Check for foreign matters (water, kerosene, etc.) in fuel and replace if necessary.

NO : Check end.

Inspection Procedure 8: Unstable Idling (Rough idling, hunting), Improper Idling Speed (Too high or too low), Engine Stalls During Idling (Die out)

COMMENT ON TROUBLE SYMPTOM

- Probable causes can be widely found in ignition system, air-fuel ratio control system, idle speed control system, fuel system, etc. A sudden engine stall is possibly caused by poor connector contact.

PROBABLE CAUSE

- Failed ignition system
- Failed fuel system
- Failed air-fuel ratio control system
- Failed idle speed control system
- Failed intake/exhaust system
- Failed emission gas cleaning system
- Throttle valve body fouled
- Timing belt out of place
- Compression pressure improper
- Failed engine-ECU <M/T>
- Failed engine-A/T-ECU <A/T>

DIAGNOSIS PROCEDURE

STEP 1. Check battery condition.

Q: Has the battery terminal been disconnected?

YES : After warm-up engine, idle for about 10 minutes.

NO : Go to Step 2 .

STEP 2. M.U.T.-II/III diagnosis code

Q: Diagnosis code set?

YES : Inspection chart for diagnosis code (Refer to [P.13A-17](#)).

NO : Go to Step 3 .

STEP 3. M.U.T.-II/III data list

- Refer to data list reference table [P.13A-376](#).
 - a. Item 13: Intake air temperature sensor
 - b. Item 14: Throttle position sensor
 - c. Item 21: Engine coolant temperature sensor
 - d. Item 32: Manifold absolute pressure sensor

Q: Are the check results normal?

YES : Go to Step 4 .

NO : Perform the diagnosis code classified check procedure for the sensor that has shown an abnormal data value (Refer to Inspection Chart for Diagnosis Codes [P.13A-17](#)).

STEP 4. M.U.T.-II/III data list

- Refer to data list reference table [P.13A-376](#).
 - a. Item 27: Power steering fluid pressure switch

Q: Is the check result normal?

YES : Go to Step 5 .

NO : Check power steering fluid pressure switch system (Refer to Code No. P0551 [P.13A-216](#)).

STEP 5. Check idle speed control servo for operating sound.

- Check idle speed control servo for operating sound (Refer to P.13A-408).

Q: Is the check result normal?

YES : Go to Step 6 .

NO : Check idle speed control servo system (Refer to Code No. P0505 P.13A-206).

STEP 6. Check throttle body (throttle valve portion) for contamination.

Q: Is the check result normal?

YES : Go to Step 7 .

NO : Clean throttle body (throttle valve portion) (Refer to P.13A-398).

STEP 7. Check air intake from intake hose and inlet manifold.

Q: Is the check result normal?

YES : Go to Step 8 .

NO : Repair.

STEP 8. Check injector for operating sound.

- Check injector for operating sound (Refer to P.13A-407).

Q: Can operating sound be heard?

YES : Go to Step 9 .

NO : Check the injector system of the defective cylinder.

(Refer to Code No. P0201: No. 1 injector system P.13A-115.)

(Refer to Code No. P0202: No. 2 injector system P.13A-121.)

(Refer to Code No. P0203: No. 3 injector system P.13A-127.)

(Refer to Code No. P0204: No. 4 injector system P.13A-133.)

STEP 9. Check timing marks of timing belt.

Q: Is the check result normal?

YES : Go to Step 10 .

NO : Align timing marks.

STEP 10. M.U.T.-II/III data list

- Refer to data list reference table P.13A-376.
 - Item 11: Oxygen sensor (front)

Q: Is the check result normal?

YES : Go to Step 11 .

NO : Check oxygen sensor (front) system (Refer to Code No. P0130 P.13A-74).

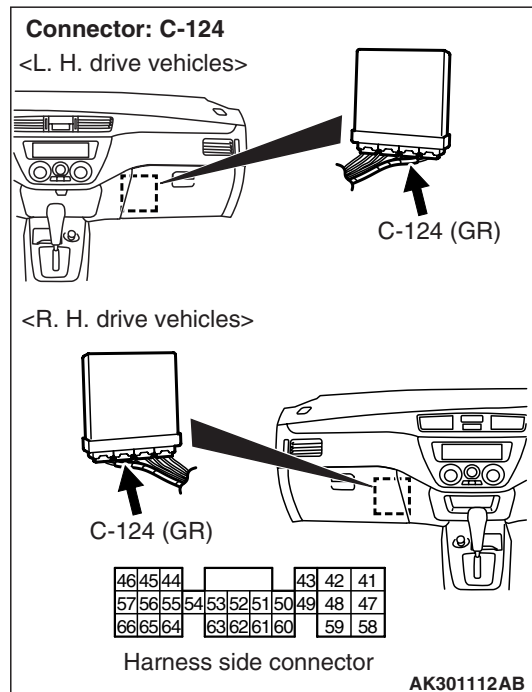
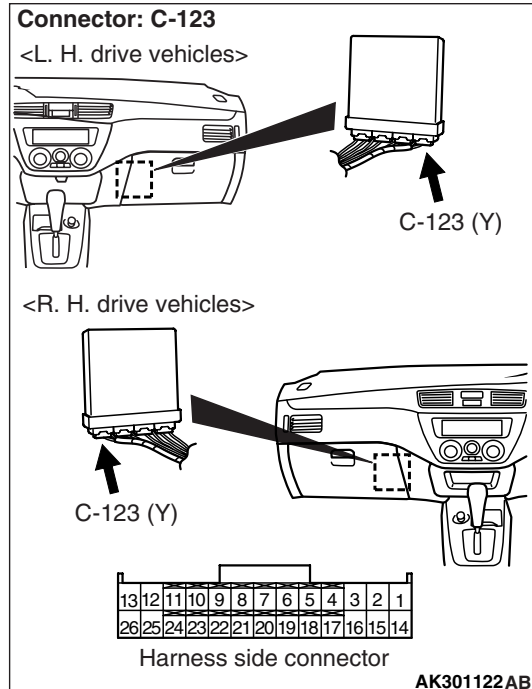
STEP 11. Perform voltage measurement at C-123 engine-ECU <M/T> connector or C-124 engine-A/T-ECU <A/T> connector.

- Measure engine-ECU <M/T> or engine-A/T-ECU <A/T> terminal voltage.
- Ignition switch: ON
- Voltage between terminal No. 13 <M/T> or terminal No. 48 <A/T> and earth, also between terminal No. 26 <M/T> or terminal No. 42 <A/T> and earth.

OK: 0.5 V or less

Q: Is the check result normal?

YES : Go to Step 13 .

NO : Go to Step 12 .

Q: Is the check result normal?

YES : Check and repair harness between C-123 (terminal No. 13 and No. 26) engine-ECU <M/T> connector or C-124 (terminal No. 42 and No. 48) engine-A/T-ECU <A/T> connector and body earth.

- Check earthing line for open circuit and damage.

NO : Repair or replace.

STEP 12. Connector check: C-123 engine-ECU <M/T> connector or C-124 engine-A/T-ECU <A/T> connector

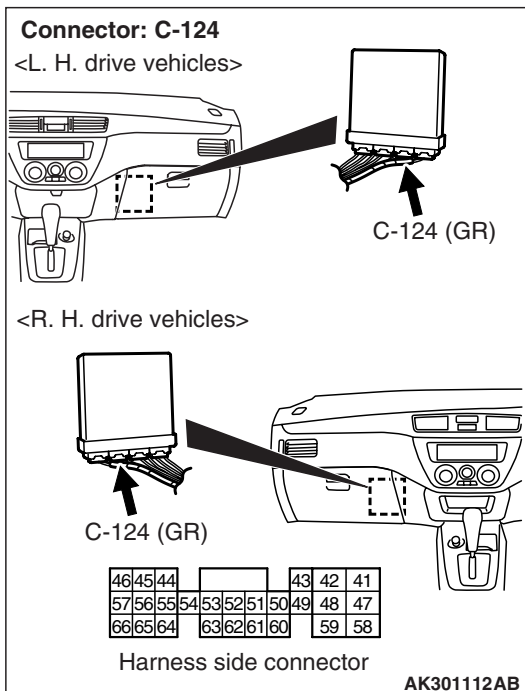
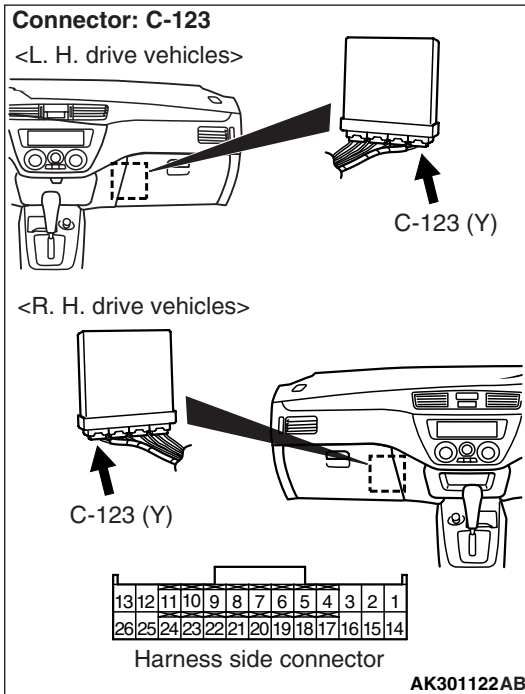

STEP 13. Perform voltage measurement at C-125 engine-ECU <M/T> connector or C-122 engine-A/T-ECU <A/T> connector.

OK: Switching the headlamps to ON from OFF causes the voltage to increase by 0.2 – 3.5 V.

Q: Is the check result normal?
YES : Go to Step 16 .
NO : Go to Step 14 .

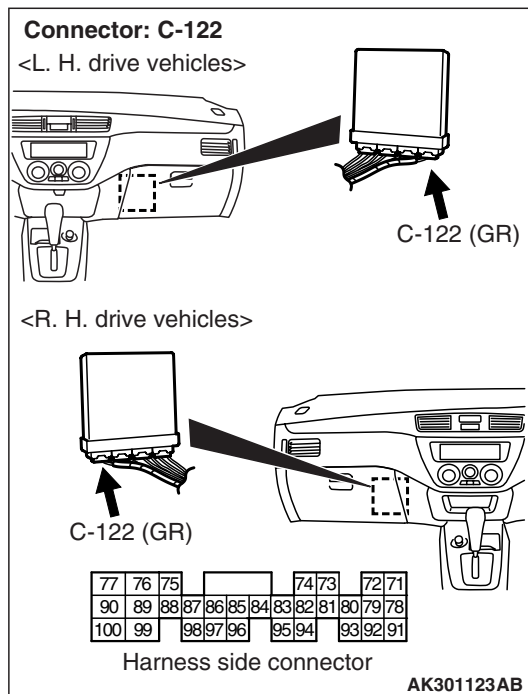
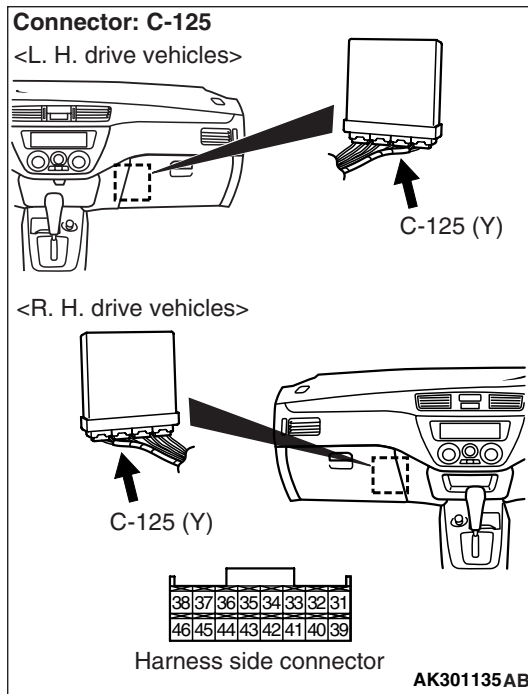

- Measure engine-ECU <M/T> or engine-A/T-ECU <A/T> terminal voltage.
- Engine: Idling after warm-up
- Transmission: Neutral <M/T> or P range <A/T>
- Radiator fan: Not operating
- Voltage between terminal No. 33 <M/T> or terminal No. 8 <A/T> and earth.

STEP 14. Connector check: C-125 engine-ECU <M/T> connector or C-122 engine-A/T-ECU <A/T> connector and B-26 alternator connector

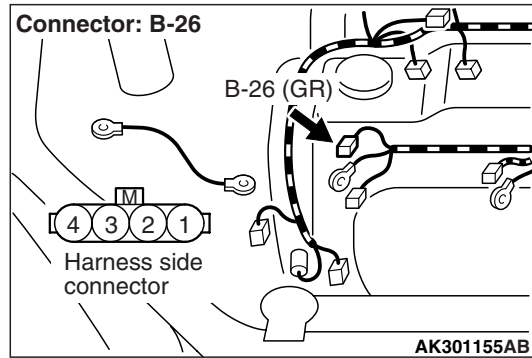
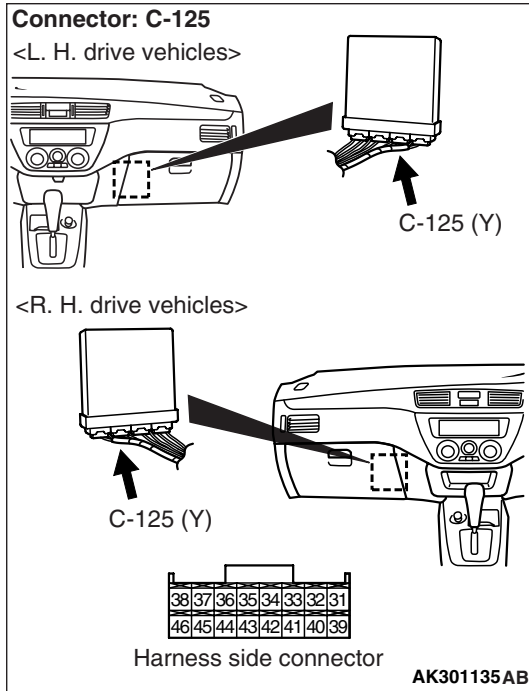

Q: Is the check result normal?
YES : Go to Step 15 .
NO : Repair or replace.

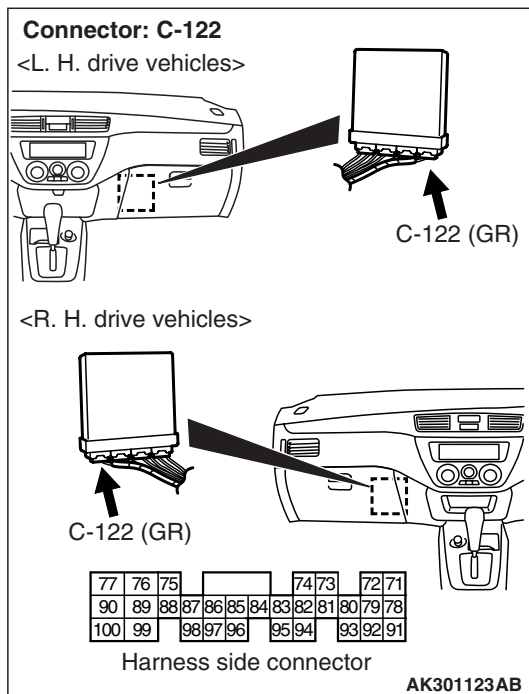

STEP 15. Check harness between C-125 (terminal No. 33) engine-ECU <M/T> connector or C-122 (terminal No. 8) engine-A/T-ECU <A/T> connector and B-26 (terminal No. 1) alternator connector.

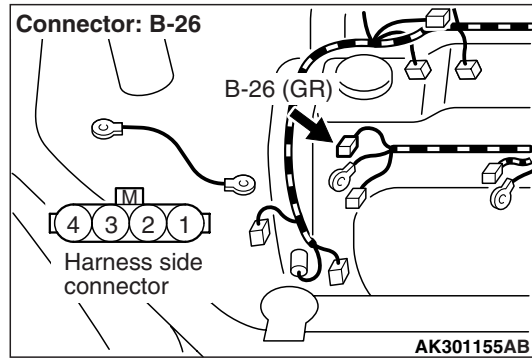
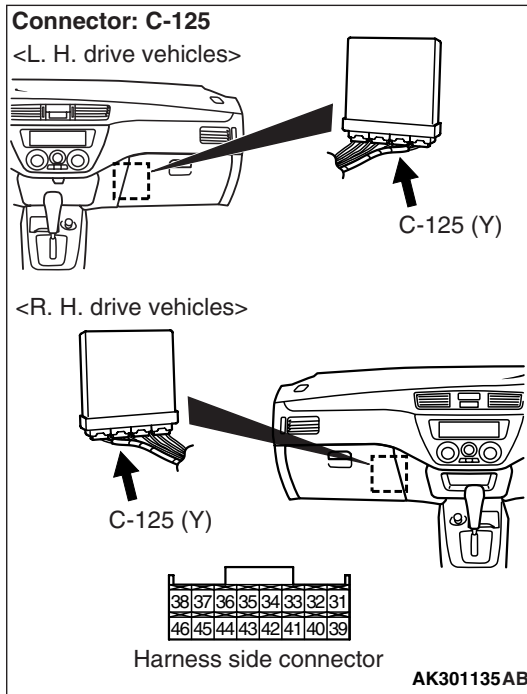

NOTE: Before checking harness, check intermediate connector B-18, and repair if necessary.

- Check output line for open/short circuit and damage.

Q: Is the check result normal?

YES : Go to Step 16 .

NO : Repair.

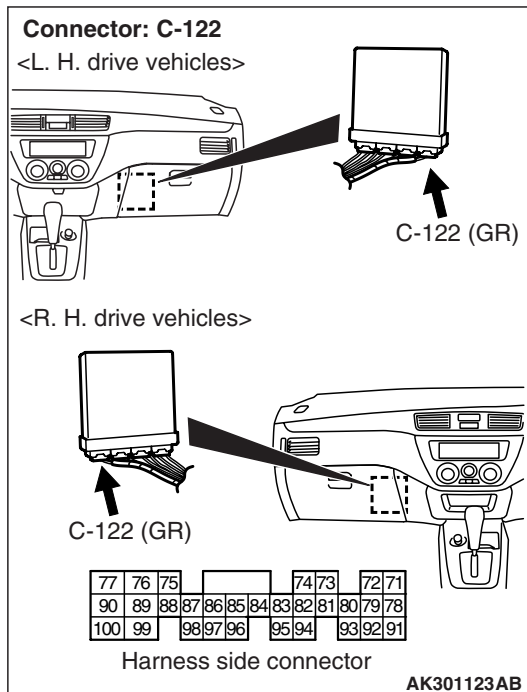

STEP 16. Perform voltage measurement at C-125 engine-ECU <M/T> connector or C-122 engine-A/T-ECU <A/T> connector.

OK: Switching the headlamps to ON from OFF causes the voltage to fall.

Q: Is the check result normal?

YES : Go to Step 20 .

NO : Go to Step 17 .

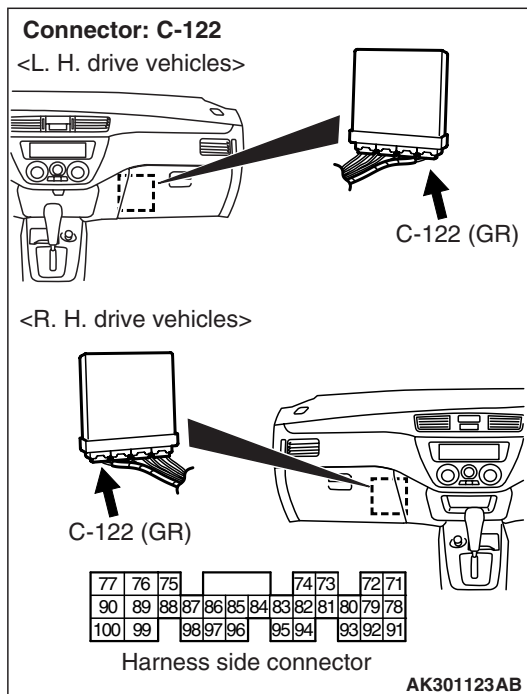
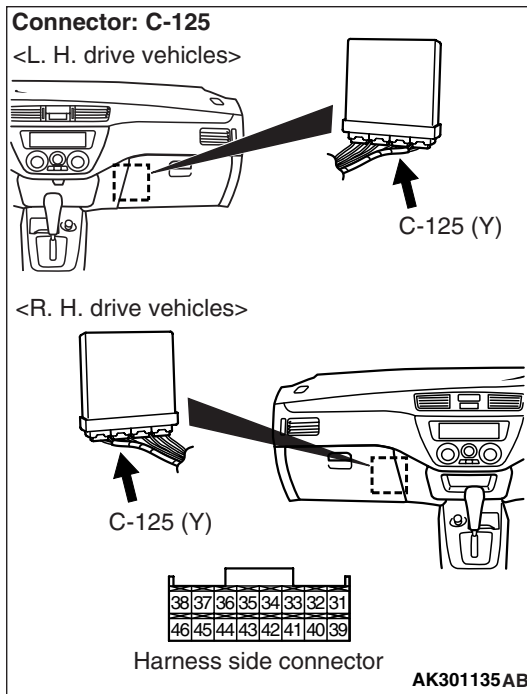

- Measure engine-ECU <M/T> or engine-A/T-ECU <A/T> terminal voltage.
- Engine: Idling after warm-up
- Transmission: Neutral <M/T> or P range <A/T>
- Radiator fan: Not operating
- Voltage between terminal No. 33 <M/T> or terminal No. 8 <A/T> and earth.

STEP 17. Connector check: C-125 engine-ECU <M/T> connector or C-122 engine-A/T-ECU <A/T> connector and B-26 alternator connector

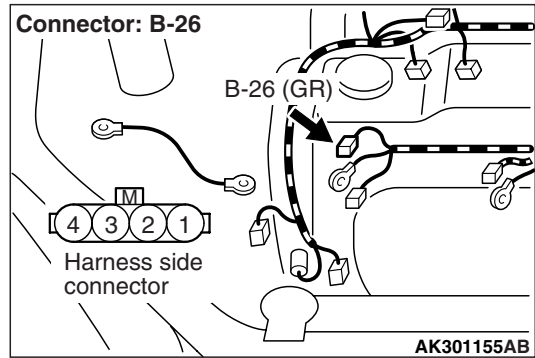
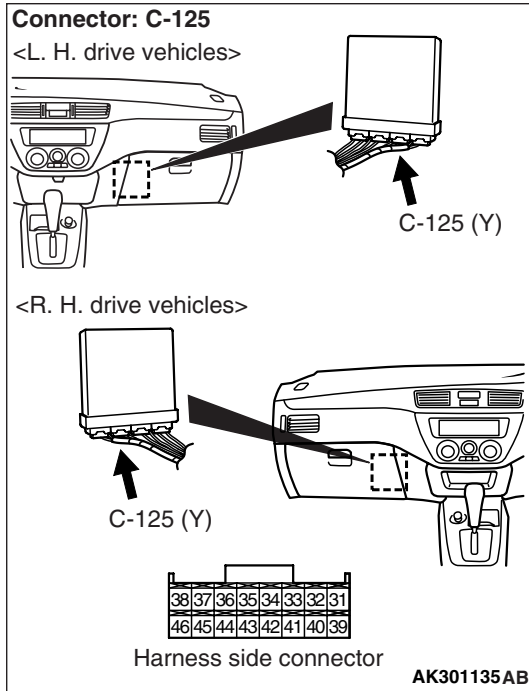

Q: Is the check result normal?
YES : Go to Step 18 .
NO : Repair or replace.

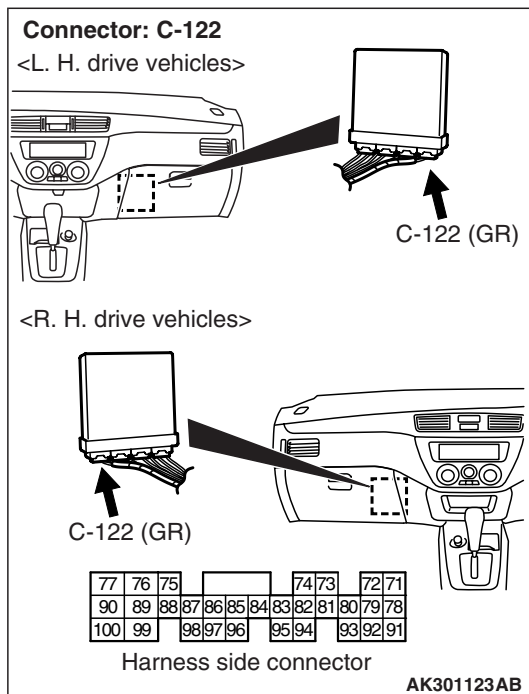

STEP 18. Check harness between C-125 (terminal No. 41) engine-ECU <M/T> connector or C-124 (terminal No. 54) engine-A/T-ECU <A/T> connector and B-26 (terminal No. 4) alternator connector.

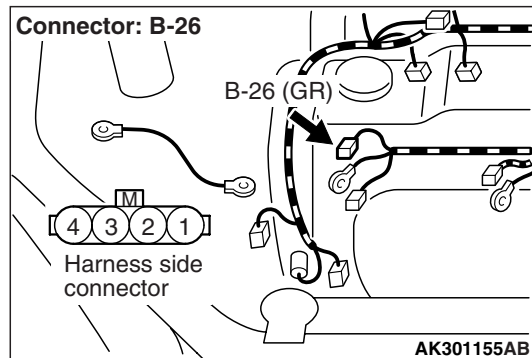
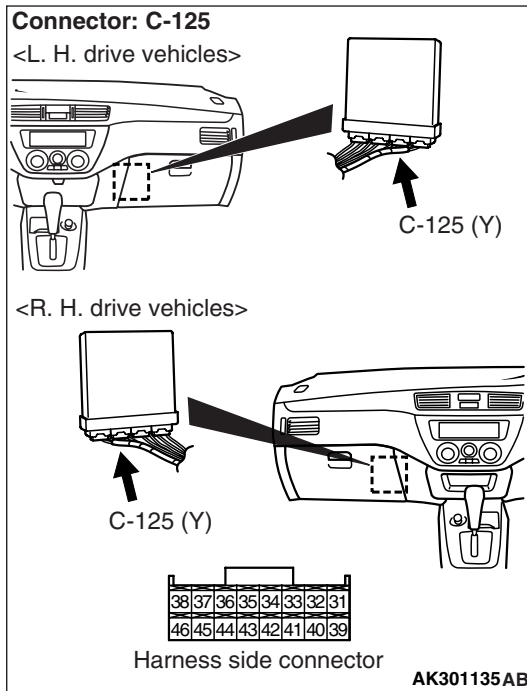

NOTE: Before checking harness, check intermediate connector B-18, and repair if necessary.

- Check output line for open/short circuit and damage.

Q: Is the check result normal?

YES : Go to Step 19 .

NO : Repair.

STEP 19. Check the trouble symptoms.

Q: Does trouble symptom persist?

YES : Replace alternator.

NO : Intermittent malfunction (Refer to GROUP 00 –How to Use Troubleshooting/Inspection Service Points P.00-5).

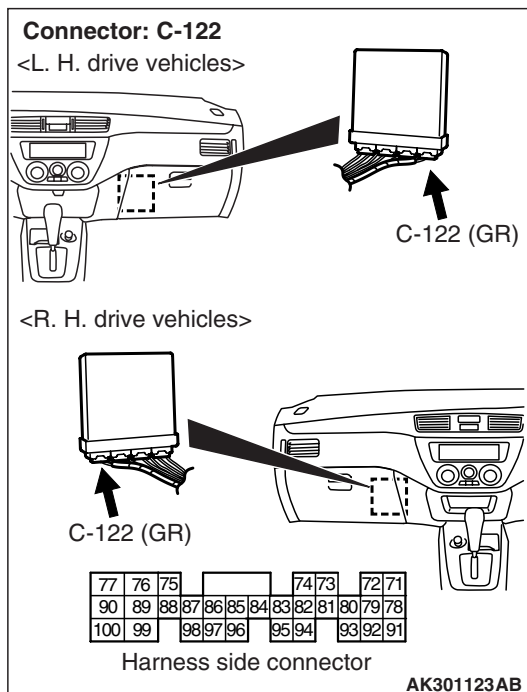

STEP 20. Perform voltage measurement at C-123 engine-ECU <M/T> connector or C-124 engine-A/T-ECU <A/T> connector.

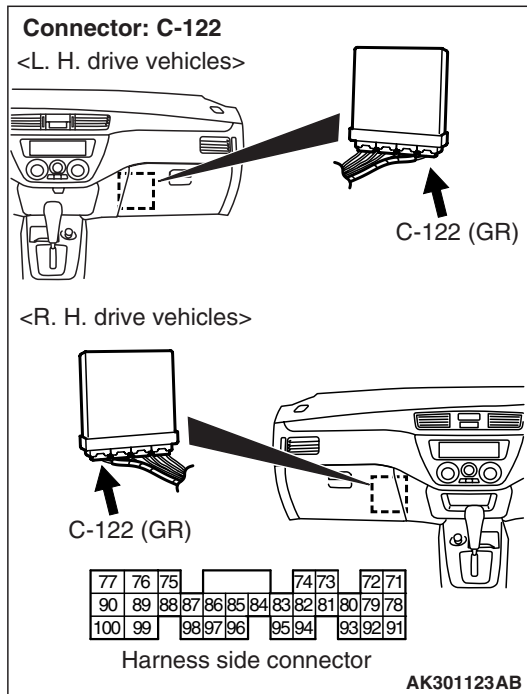
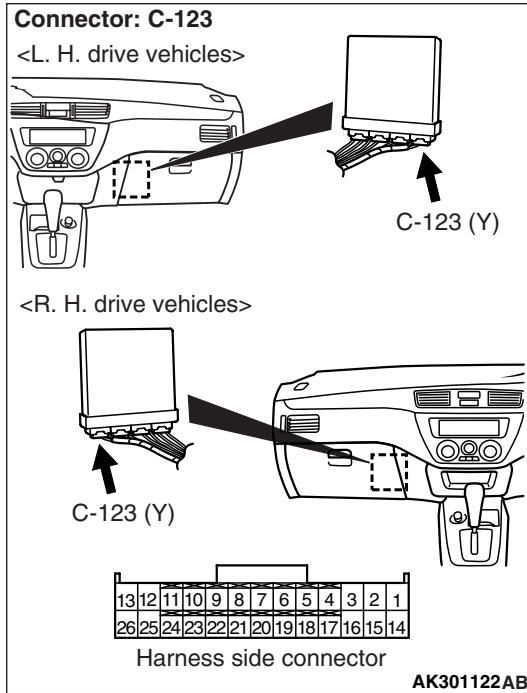

- Measure engine-ECU <M/T> or engine-A/T-ECU <A/T> terminal voltage.
- Engine: Idling
- A/C switch: ON (A/C compressor ON)
- Voltage between terminal No. 24 <M/T> or terminal No. 61 <A/T> and earth.

OK:
1 V or less (when the A/C is under low load)
System voltage (when the A/C is under high load)

- Q: Is the check result normal?**
YES : Go to Step 21 .
NO : Check A/C load signal system (Refer to Inspection Procedure 27 P.13A-355).

STEP 21. Connector check: B-104 and B-113 ignition coil connectors

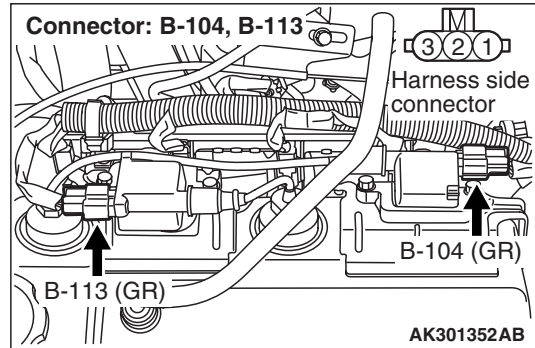

- Q: Is the check result normal?**
YES : Go to Step 22 .
NO : Repair or replace.

STEP 22. Check ignition secondary voltage waveform using an oscilloscope.

- Check ignition secondary voltage waveform (Refer to GROUP 16 –Ignition System –On-vehicle Service P.16-32).

- Q: Is the check result normal?**
YES : Go to Step 27 .
NO : Go to Step 23 .

STEP 23. Check spark plug.

- Check spark plug (Refer to GROUP 16 –Ignition System –On-vehicle Service P.16-31).

- Q: Is the check result normal?**
YES : Go to Step 24 .
NO : Replace spark plug.

STEP 24. Check resistive cord

- Check resistive cord itself (Refer to GROUP 16 – Ignition System –On-vehicle Service P.16-30).

- Q: Is the check result normal?**
YES : Go to Step 25 .
NO : Replace resistive cord.

STEP 25. Check ignition coil itself.

- Check ignition coil itself (Refer to GROUP 16 – Ignition System –On-vehicle Service P.16-30).

Q: Is the check result normal?

YES : Go to Step 26 .

NO : Replace ignition coil.

STEP 26. Check harness between terminal No. 2 of ignition coil connector of each cylinder and body earth.

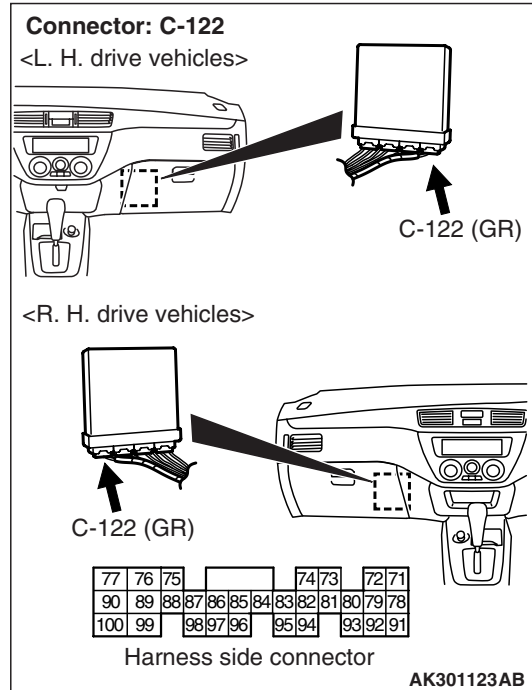
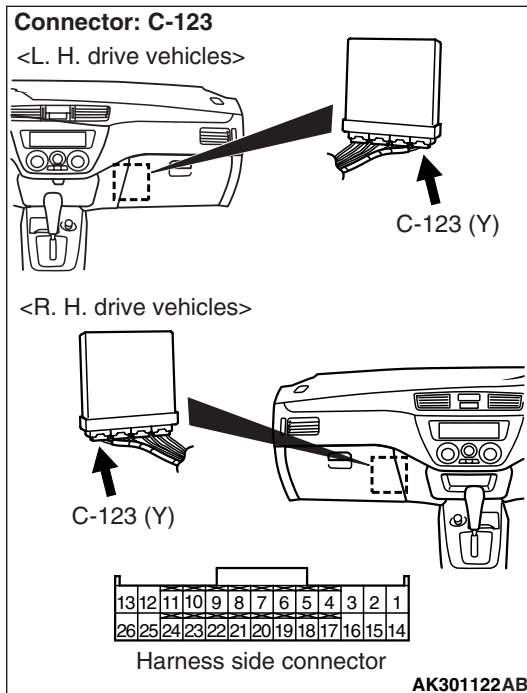
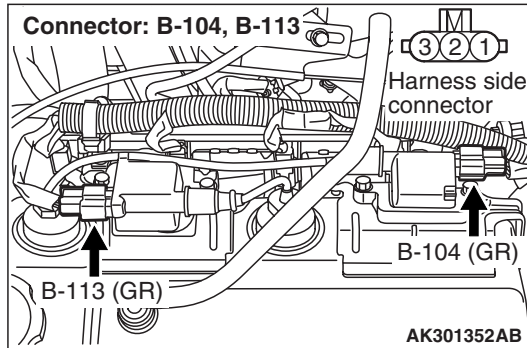

- Check earthing line for open/short circuit and damage.

Q: Is the check result normal?

YES : Check and repair harness between terminal No. 3 of ignition coil connector of each cylinder and C-123 engine-ECU <M/T> or C-122 engine-A/T-ECU <A/T>.

- Check signal line for open/short and damage.

NO : Repair.

STEP 27. Check injector for spray condition.

- Check each injector for spray condition (Refer to P.13A-407).

Q: Is the check result normal?

YES : Go to Step 28 .

NO : Replace injector.

STEP 28. Check compression pressure.

- Check compression pressure (Refer to GROUP 11A –On-vehicle Service P.11A-12).

Q: Is the check result normal?

YES : Go to Step 29 .

NO : Repair.

STEP 29. Check purge control solenoid valve itself.

- Check purge control solenoid valve itself (Refer to GROUP 17 –Emission Control System –Evaporative Emission Control System [P.17-11](#))

Q: Is the check result normal?

YES : Go to Step 30 .

NO : Replace purge control solenoid valve.

STEP 30. Check EGR control solenoid valve itself.

- Check EGR control solenoid valve itself [Refer to GROUP 17 –Emission Control System – Exhaust Gas Recirculation (EGR) System [P.17-16](#)].

Q: Is the check result normal?

YES : Go to Step 31 .

NO : Replace EGR control solenoid valve.

STEP 31. Check EGR valve itself.

- Check EGR valve itself [Refer to GROUP 17 – Emission Control System – Exhaust Gas Recirculation (EGR) System [P.17-15](#)].

Q: Is the check result normal?

YES : Go to Step 32 .

NO : Replace EGR valve.

STEP 32. M.U.T.-II/III actuator test

- Refer to actuator test reference table [P.13A-383](#).
 - Item 07: Fuel pump

OK: Operating sounds of fuel pump can be heard.

Q: Is the check result normal?

YES : Go to Step 33 .

NO : Check fuel pump system (Refer to inspection Procedure 24 [P.13A-334](#)).

STEP 33. Replace engine-ECU <M/T> or engine-A/T-ECU <A/T>.

- After engine-ECU <M/T> or engine-A/T-ECU <A/T> is replaced, re-check for trouble symptom.

Q: Do trouble system persist?

YES : Check for foreign matters (water, kerosene, etc.) in fuel and replace if necessary.

NO : Check end.

Inspection Procedure 9: The Engine Stalls when Starting the Car (Pass out)**COMMENT ON TROUBLE SYMPTOM**

- Engine stall on starting is possibly caused by misfire due to failed spark plug, improper air-fuel ratio at accelerator pedal depression or other faults.

PROBABLE CAUSE

- Failed ignition system
- Failed intake system
- Failed emission gas cleaning system
- Failed engine-ECU <M/T>
- Failed engine-A/T-ECU <A/T>

DIAGNOSIS PROCEDURE**STEP 1. M.U.T.-II/III diagnosis code**

Q: Diagnosis code set?

YES : Inspection chart for diagnosis code (Refer to [P.13A-17](#)).

NO : Go to Step 2 .

STEP 2. Check EGR control solenoid valve itself.

- Check EGR control solenoid valve itself [Refer to GROUP 17 –Emission Control System – Exhaust Gas Recirculation (EGR) System [P.17-16](#)].

Q: Is the check result normal?

YES : Go to Step 3 .

NO : Replace EGR control solenoid valve.

STEP 3. Check EGR valve itself.

- Check EGR valve itself [Refer to GROUP 17 – Emission Control System – Exhaust Gas Recirculation (EGR) System [P.17-15](#)].

Q: Is the check result normal?

YES : Go to Step 4 .

NO : Replace EGR valve.

STEP 4. Check air intake from intake hose and inlet manifold.

- Q: Is the check result normal?**
YES : Go to Step 5 .
NO : Repair.

STEP 5. Connector check: B-104 and B-113 ignition connectors.

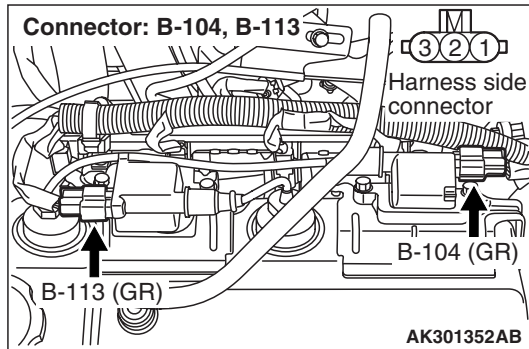

- Q: Is the check result normal?**
YES : Go to Step 6 .
NO : Repair or replace.

STEP 6. Check ignition secondary voltage waveform using an oscilloscope.

- Check ignition secondary voltage waveform (Refer to GROUP 16 –Ignition System –On-vehicle Service [P.16-32](#)).

- Q: Is the check result normal?**
YES : Replace engine-ECU <M/T> or engine-A/T-ECU <A/T>.
NO : Go to Step 7 .

STEP 7. Check spark plug.

- Check spark plug (Refer to GROUP 16 –Ignition System –On-vehicle Service [P.16-31](#)).

- Q: Is the check result normal?**
YES : Go to Step 8 .
NO : Replace spark plug.

STEP 8. Check resistive cord itself.

- Check resistive cord itself (Refer to GROUP 16 – Ignition System –On-vehicle Service [P.16-30](#)).

- Q: Is the check result normal?**
YES : Go to Step 9 .
NO : Replace resistive cord.

STEP 9. Check ignition coil itself.

- Check ignition coil itself (Refer to GROUP 16 – Ignition System –On-vehicle Service [P.16-30](#)).

- Q: Is the check result normal?**
YES : Go to Step 10 .
NO : Replace ignition coil.

STEP 10. Check harness between terminal No. 2 of ignition coil connector of each cylinder and body earth.

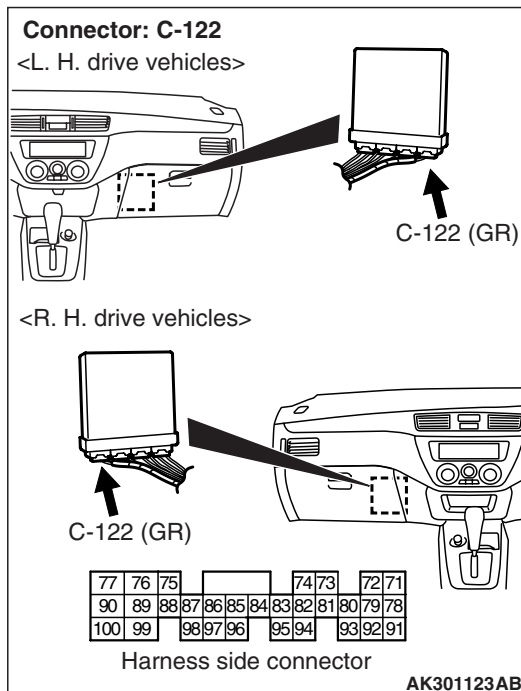
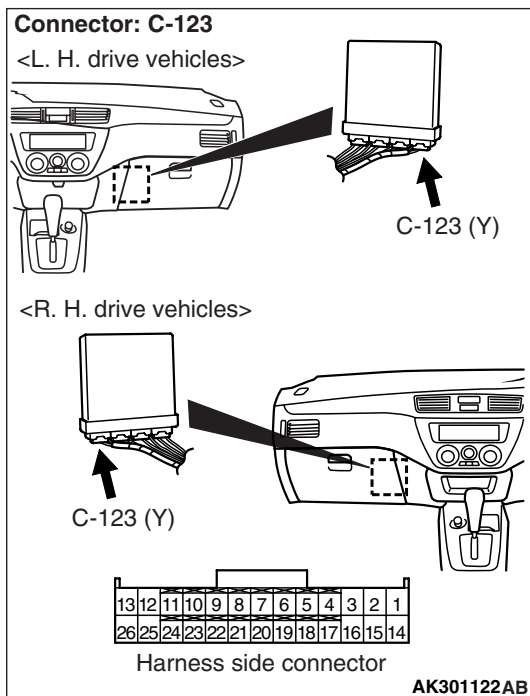
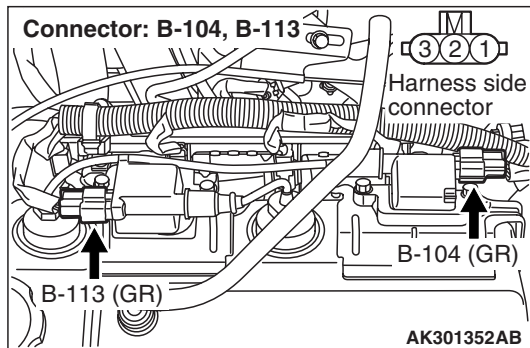

- Check earthing line for open circuit and damage.

Q: Is the check result normal?

YES : Check and repair harness between terminal No. 3 of ignition coil connector of each cylinder and C-123 engine-ECU <M/T> or C-122 engine-A/T-ECU <A/T>.

- Check signal line for open/short circuit and damage.

NO : Repair.

Inspection Procedure 10: The Engine Stalls when Decelerating

COMMENT ON TROUBLE SYMPTOM

- Engine stall on deceleration is possibly caused by insufficient air intake, improper air-fuel ratio due to failed exhaust gas recirculation system or other faults.

PROBABLE CAUSE

- Failed idle speed control system
- Failed ignition system
- Failed emission control system
- Throttle valve fouled

- Failed engine-ECU <M/T>
- Failed engine-A/T-ECU <A/T>

DIAGNOSIS PROCEDURE

STEP 1. M.U.T.-II/III diagnosis code

Q: Diagnosis code set?

YES : Inspection chart for diagnosis code (Refer to P.13A-17).

NO : Go to Step 2 .

STEP 2. M.U.T.-II/III data list

- Refer to data list reference table [P.13A-376](#).
 - Item 14: Throttle position sensor

Q: Is the check result normal?

YES : Go to Step 3 .

NO : Check throttle position sensor system
(Refer to Code No. P0120 [P.13A-54](#)).

STEP 3. M.U.T.-II/III data list

- Refer to data list reference table [P.13A-376](#).
 - Item 45: Idle speed control servo position

OK: Idle speed control servo drops to 0 –2 steps at deceleration (engine at 1,000 r/min or higher).

Q: Is the check result normal?

YES : Go to Step 4 .

NO : Check idle speed control servo system
(Refer to Code No. P0505 [P.13A-206](#)).

STEP 4. Check EGR control solenoid valve itself.

- Check EGR control solenoid valve itself [Refer to GROUP 17 –Emission Control System – Exhaust Gas Recirculation (EGR) System [P.17-16](#)].

Q: Is the check result normal?

YES : Go to Step 5 .

NO : Replace EGR control solenoid valve.

STEP 5. Check EGR valve itself.

- Check EGR valve itself [Refer to GROUP 17 – Emission Control System – Exhaust Gas Recirculation (EGR) System [P.17-15](#)].

Q: Is the check result normal?

YES : Go to Step 6 .

NO : Replace EGR valve.

STEP 6. Check throttle body (throttle valve portion) for contamination.

Q: Is the check result normal?

YES : Go to Step 7 .

NO : Clean throttle body (throttle valve portion)
(Refer to [P.13A-398](#)).

STEP 7. Connector check: B-104 and B-113 ignition coil connectors

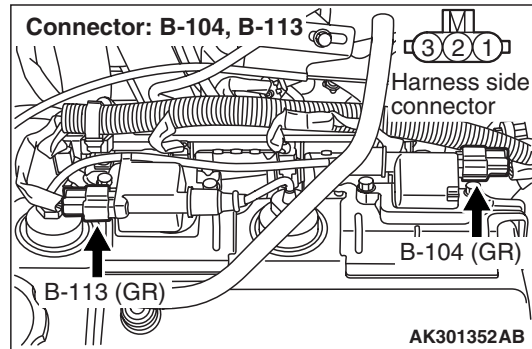

Q: Is the check result normal?

YES : Go to Step 8 .

NO : Repair or replace.

STEP 8. Check ignition secondary voltage waveform using an oscilloscope.

- Check ignition secondary voltage waveform (Refer to GROUP 16 –Ignition System –On-vehicle Service [P.16-32](#)).

Q: Is the check result normal?

YES : Replace engine-ECU <M/T> or engine-A/T-ECU <A/T>.

NO : Go to Step 9 .

STEP 9. Check spark plug.

- Check spark plug (Refer to GROUP 16 –Ignition System –On-vehicle Service [P.16-31](#)).

Q: Is the check result normal?

YES : Go to Step 10 .

NO : Replace spark plug.

STEP 10. Check resistive cord itself.

- Check resistive cord itself (Refer to GROUP 16 – Ignition System –On-vehicle Service [P.16-30](#)).

Q: Is the check result normal?

YES : Go to Step 11 .

NO : Replace resistive cord.

STEP 11. Check ignition coil itself.

- Check ignition coil itself (Refer to GROUP 16 – Ignition System –On-vehicle Service P.16-30).

Q: Is the check result normal?

YES : Go to Step 12 .

NO : Replace ignition coil.

STEP 12. Check harness between terminal No. 2 of ignition coil connector of each cylinder and body earth.

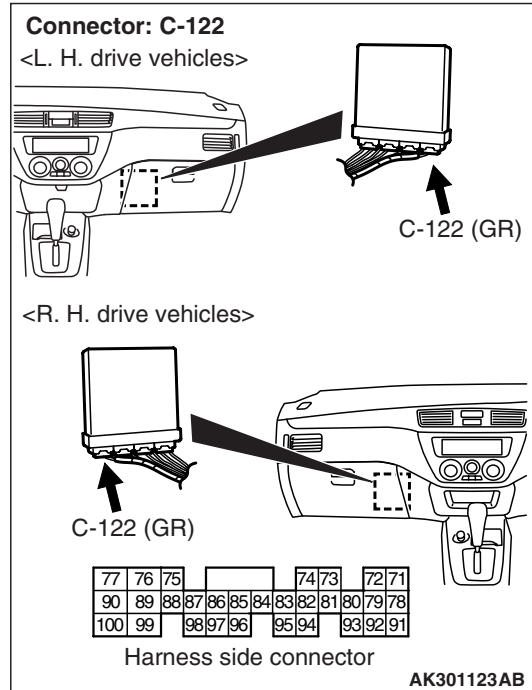
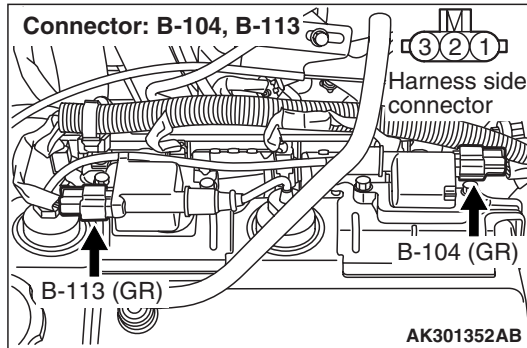

- Check earthing line for open circuit and damage.

Q: Is the check result normal?

YES : Check and repair harness between terminal No. 3 of ignition coil connector of each cylinder and C-123 engine-ECU <M/T> or C-122 engine-A/T-ECU <A/T>.

- Check signal line for open/short circuit and damage.

NO : Repair.

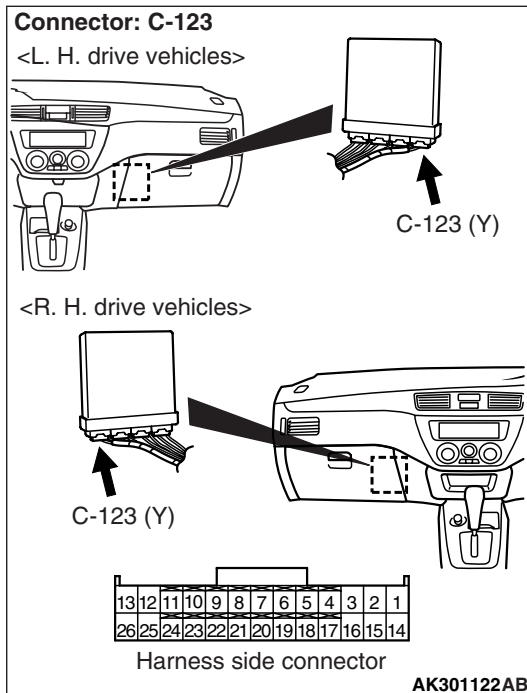

Inspection Procedure 11: Engine Does Not Revolve Up

COMMENT ON TROUBLE SYMPTOM

- Failure is possibly caused by failed fuel system, ignition system or other faults.

PROBABLE CAUSE

- Failed ignition system
- Failed fuel system
- Timing belt out of place
- Failed engine-ECU <M/T>
- Failed engine-A/T-ECU <A/T>

DIAGNOSIS PROCEDURE

STEP 1. M.U.T.-II/III diagnosis code

Q: Diagnosis code set?

YES : Inspection chart for diagnosis code (Refer to P.13A-17).

NO : Go to Step 2 .

STEP 2. Check timing marks of timing belt.

Q: Is the check result normal?

YES : Go to Step 3 .

NO : Align match marks.

STEP 3. Connector check: B-104 and B-113 ignition coil connectors

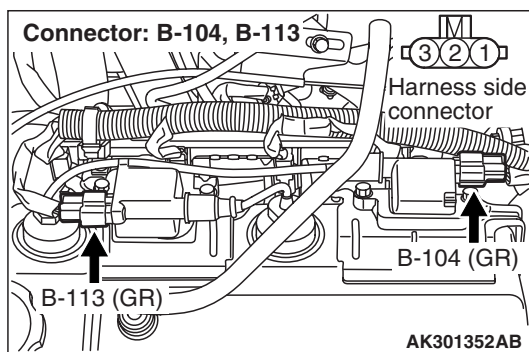

Q: Is the check result normal?

YES : Go to Step 4 .

NO : Repair or replace

STEP 4. Check ignition secondary voltage waveform using an oscilloscope.

- Check ignition secondary voltage waveform (Refer to GROUP 16 –Ignition System –On-vehicle Service P.16-32).

Q: Is the check result normal?

YES : Go to Step 9 .

NO : Go to Step 5 .

STEP 5. Check spark plug.

- Check spark plug (Refer to GROUP 16 –Ignition System –On-vehicle Service P.16-31).

Q: Is the check result normal?

YES : Go to Step 6 .

NO : Replace spark plug.

STEP 6. Check resistive cord itself.

- Check resistive cord itself (Refer to GROUP 16 – Ignition System –On-vehicle Service P.16-30).

Q: Is the check result normal?

YES : Go to Step 7 .

NO : Replace resistive cord.

STEP 7. Check ignition coil itself.

- Check ignition coil itself (Refer to GROUP 16 – Ignition System –On-vehicle Service P.16-30).

Q: Is the check result normal?

YES : Go to Step 8 .

NO : Replace ignition coil.

STEP 8. Check harness between terminal No. 2 of ignition coil connector of each cylinder and body earth.

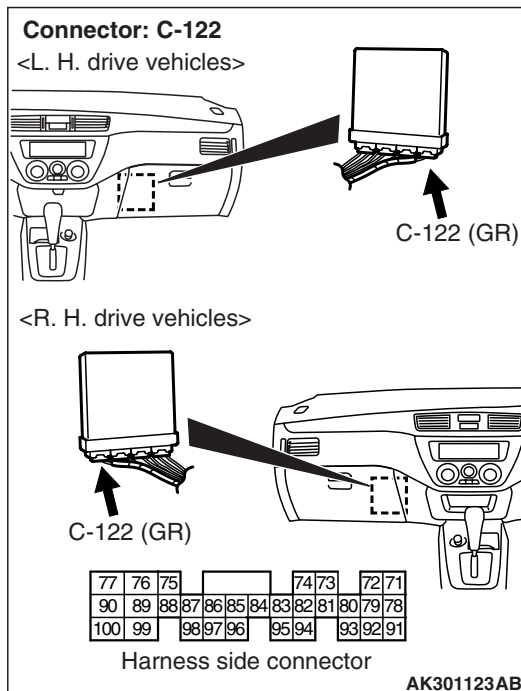
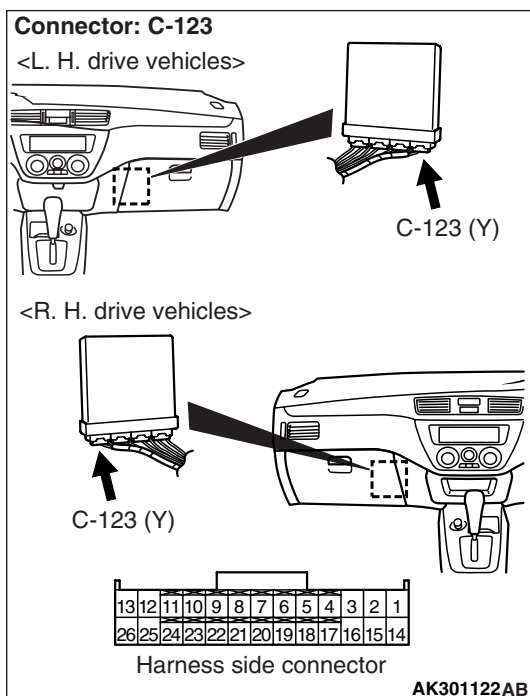
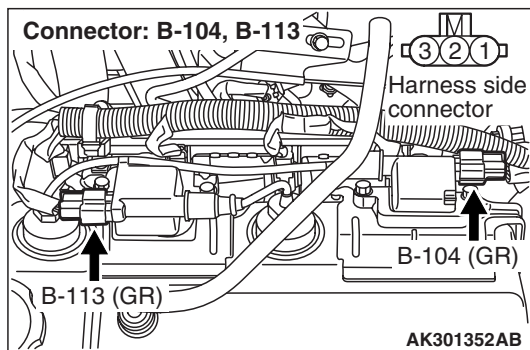

- Check earthing line for open circuit and damage.

Q: Is the check result normal?

YES : Check and repair harness between terminal No. 3 of ignition coil connector of each cylinder and C-123 engine-ECU <M/T> or C-122 engine-A/T-ECU <A/T>.

- Check signal line for open/short circuit and damage.

NO : Repair.

STEP 9. Fuel pressure measurement.

- Fuel pressure measurement (Refer to [P.13A-399](#)).

Q: Is the check result normal?

YES : Replace engine-ECU <M/T> or engine-A/T-ECU <A/T>.

NO : Repair.

Inspection Procedure 12: Hesitation, Sag, Poor Acceleration, Stumble, Surge

COMMENT ON TROUBLE SYMPTOM

- Failure is possibly caused by failed ignition system, improper air-fuel ratio, improper compression pressure or other faults.

PROBABLE CAUSE

- Failed air-fuel ratio control system
- Failed ignition system

- Failed fuel system
- Failed intake and exhaust system
- Failed emission control system
- Throttle valve fouled
- Improper compression pressure
- Failed engine-ECU <M/T>
- Failed engine-A/T-ECU <A/T>

DIAGNOSIS PROCEDURE

STEP 1. M.U.T.-II/III diagnosis code

Q: Diagnosis code set?

YES : Inspection chart for diagnosis code (Refer to P.13A-17).

NO : Go to Step 2 .

STEP 2. Check injector for operating sound.

- Check injector for operating sound (Refer to P.13A-407).

Q: Can operating sound be heard?

YES : Go to Step 3 .

NO : Check the injector system of the defective cylinder.

(Refer to code No. P0201: No. 1 injector system P.13A-115).

(Refer to code No. P0202: No. 2 injector system P.13A-121).

(Refer to code No. P0203: No. 3 injector system P.13A-127).

(Refer to code No. P0204: No. 4 injector system P.13A-133).

STEP 3. M.U.T.-II/III data list

- Refer to data list reference table P.13A-376.
 - Item 14: Throttle position sensor
 - Item 21: Engine coolant temperature sensor
 - Item 32: Manifold absolute pressure sensor

Q: Are the check results normal?

YES : Go to Step 4 .

NO : Perform the diagnosis code classified check procedure for the sensor that has shown an abnormal data value (Refer to Inspection Chart for diagnosis codes P.13A-17).

STEP 4. Check purge control solenoid valve itself.

- Check purge control solenoid valve itself (Refer to GROUP 17 –Emission Control System –Evaporative Emission Control System P.17-11).

Q: Is the check result normal?

YES : Go to Step 5 .

NO : Replace purge control solenoid valve.

STEP 5. Check EGR control solenoid valve itself.

- Check EGR control solenoid valve itself [Refer to GROUP 17 –Emission Control System – Exhaust Gas Recirculation (EGR) System P.17-16].

Q: Is the check result normal?

YES : Go to Step 6 .

NO : Replace EGR control solenoid valve.

STEP 6. Check EGR valve itself.

- Check EGR itself [Refer to GROUP 17 –Emission Control System – Exhaust Gas Recirculation (EGR) System P.17-15].

Q: Is the check result normal?

YES : Go to Step 7 .

NO : Replace EGR valve.

STEP 7. M.U.T.-II/III data list

- Refer to data list reference table P.13A-376.
 - Item 11: Oxygen sensor (front)

Q: Is the check result normal?

YES : Go to Step 8 .

NO : Check oxygen sensor (front) system (Refer to Code No. P0130 P.13A-74).

STEP 8. Connector check: B-104 and B-113 ignition coil connectors

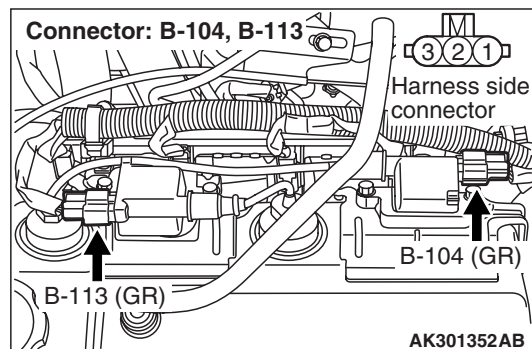

Q: Is the check result normal?

YES : Go to Step 9 .

NO : Repair or replace.

STEP 9. Check ignition secondary voltage waveform using an oscilloscope.

- Check ignition secondary voltage waveform (Refer to GROUP 16 –Ignition System –On-vehicle Service P.16-32).

Q: Is the check result normal?

YES : Go to Step 14 .

NO : Go to Step 10 .

STEP 10. Check spark plug.

- Check spark plug (Refer to GROUP 16 –Ignition System –On-vehicle Service P.16-31).

Q: Is the check result normal?

YES : Go to Step 11 .

NO : Replace spark plug.

STEP 11. Check resistive cord itself.

- Check resistive cord itself (Refer to GROUP 16 – Ignition System –On-vehicle Service P.16-30).

Q: Is the check result normal?

YES : Go to Step 12 .

NO : Replace resistive cord.

STEP 12. Check ignition coil itself.

- Check ignition coil itself (Refer to GROUP 16 – Ignition System –On-vehicle Service P.16-30).

Q: Is the check result normal?

YES : Go to Step 13 .

NO : Replace ignition coil.

STEP 13. Check harness between terminal No. 2 of ignition coil connector of each cylinder and body earth.

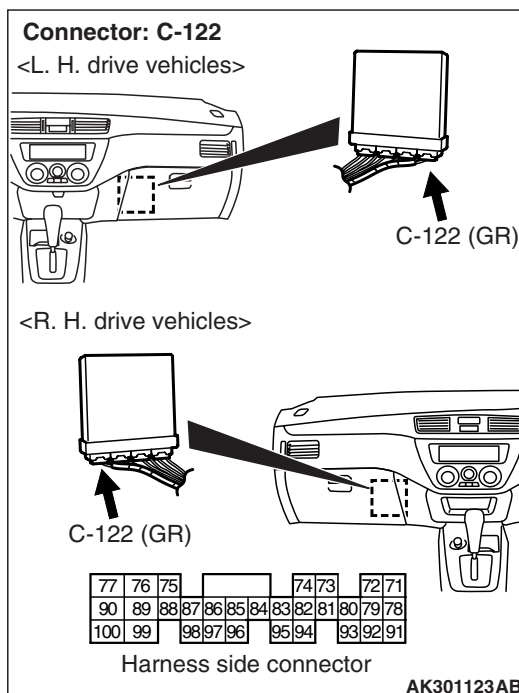
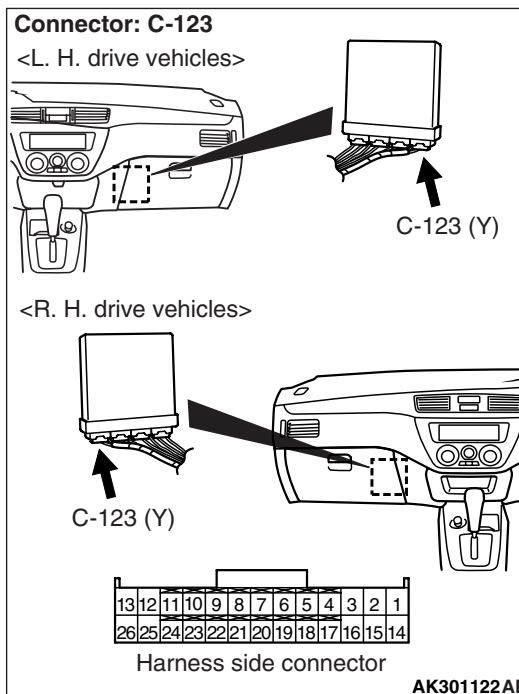
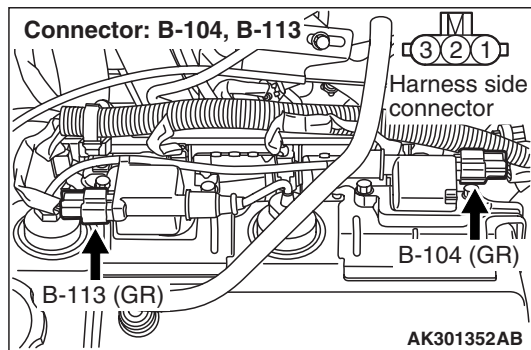

- Check earthing line for open circuit and damage.

Q: Is the check result normal?

YES : Check and repair harness between terminal No. 3 of ignition coil connector of each cylinder and C-123 engine-ECU <M/T> or C-122 engine-A/T-ECU <A/T>

- Check signal line for open/short circuit and damage.

NO : Repair.

STEP 14. Check throttle body (throttle valve portion) for contamination.

Q: Is the check result normal?

YES : Go to Step 15 .

NO : Clean throttle body (throttle valve portion)
(Refer to [P.13A-398](#)).

STEP 15. Fuel pressure measurement.

- Fuel pressure measurement (Refer to [P.13A-399](#)).

Q: Is the check result normal?

YES : Go to Step 16 .

NO : Repair.

STEP 16. Check compression pressure.

- Check compression pressure (Refer to GROUP 11A –On-vehicle Service [P.11A-12](#)).

Q: Is the check result normal?

YES : Replace engine-ECU <M/T> or engine-A/T-ECU <A/T>.

NO : Repair.

Inspection Procedure 13: The Feeling of Impact or Vibration when Accelerating

COMMENT ON TROUBLE SYMPTOM

- Failure is possibly caused by failed ignition leak with rise in spark plug required voltage at acceleration.

PROBABLE CAUSE

- Failed ignition system
- Failed engine-ECU <M/T>
- Failed engine-A/T-ECU <A/T>

DIAGNOSIS PROCEDURE

STEP 1. M.U.T.-II/III diagnosis code

Q: Diagnosis code set?

YES : Inspection chart for diagnosis code (Refer to [P.13A-17](#)).

NO : Go to Step 2 .

STEP 2. Check connector: B-104 and B-113 ignition coil connectors

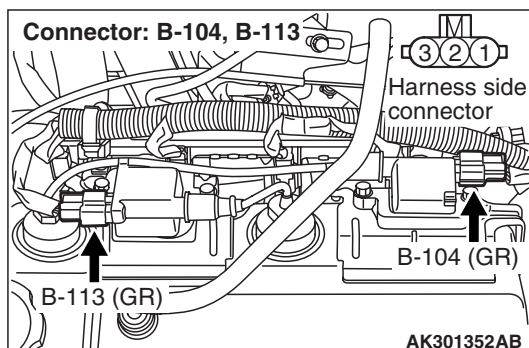

Q: Is the check result normal?

YES : Go to Step 3 .

NO : Repair or replace.

STEP 3. Check ignition secondary voltage waveform using an oscilloscope.

- Check ignition secondary voltage waveform (Refer to GROUP 16 –Ignition System –On-vehicle Service [P.16-32](#)).

Q: Is the check result normal?

YES : Replace engine-ECU <M/T> or engine-A/T-ECU <A/T>.

NO : Go to Step 4 .

STEP 4. Check spark plug.

- Check spark plug (Refer to GROUP 16 –Ignition System –On-vehicle Service [P.16-31](#)).

Q: Is the check result normal?

YES : Go to Step 5 .

NO : Replace spark plug.

STEP 5. Check resistive cord itself.

- Check resistive cord itself (Refer to GROUP 16 – Ignition System –On-vehicle Service [P.16-30](#)).

Q: Is the check result normal?

YES : Go to Step 6 .

NO : Replace resistive cord.

STEP 6. Check ignition coil itself.

- Check ignition coil itself (Refer to GROUP 16 – Ignition System –On-vehicle Service [P.16-30](#)).

Q: Is the check result normal?

YES : Go to Step 7 .

NO : Replace ignition coil.

STEP 7. Check harness between terminal No. 2 of ignition coil connector of each cylinder and body earth.

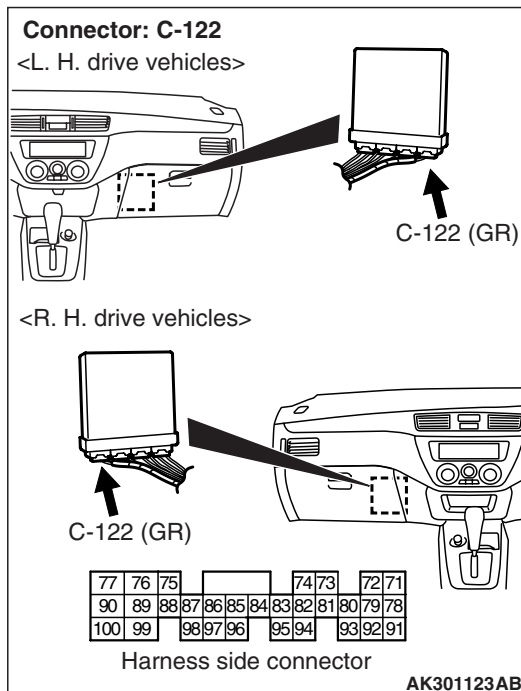
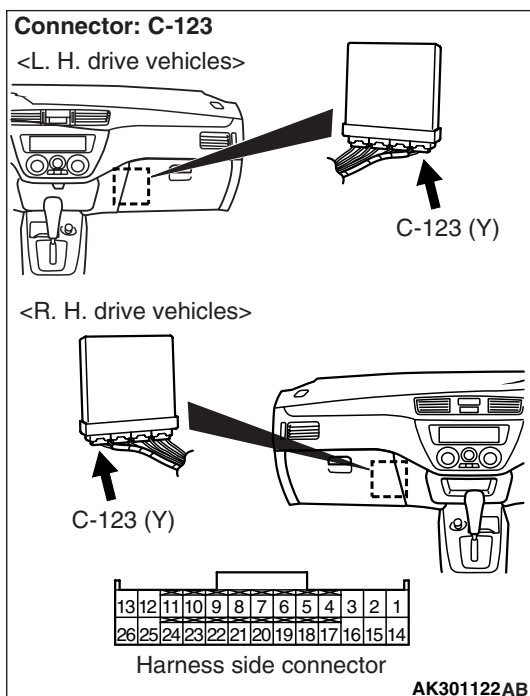
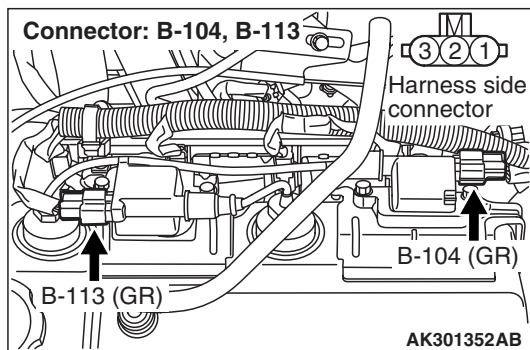

- Check earthing line for open circuit and damage.

Q: Is the check result normal?

YES : Check and repair harness between terminal 3 of ignition coil connector of each cylinder and C-123 engine-ECU <M/T> or C-122 engine-A/T-ECU <A/T>

- Check signal line for open/short circuit and damage.

NO : Repair.

Inspection Procedure 14: The Feeling of Impact or Vibration when Decelerating

COMMENT ON TROUBLE SYMPTOM

- Failure is possibly caused by insufficient air intake due to failed idle speed control system.

PROBABLE CAUSE

- Failed idle speed control system
- Throttle valve body fouled
- Failed engine-ECU <M/T>
- Failed engine-A/T-ECU <A/T>

DIAGNOSIS PROCEDURE

STEP 1. M.U.T.-II/III diagnosis code

Q: Diagnosis code set?

YES : Inspection chart for diagnosis code (Refer to P.13A-17).

NO : Go to Step 2 .

STEP 2. Check idle speed control servo for operating sound.

- Check idle speed control servo for operating sound (Refer to P.13A-408).

Q: Is the check result normal?

YES : Go to Step 3 .

NO : Check idle speed control servo system (Refer to Code No. P0505 P.13A-206).

STEP 3. M.U.T.-II/III data list

- Refer to data list reference table P.13A-376.
 - a. Item 14: Throttle position sensor

Q: Is the check result normal?

YES : Go to Step 4 .

NO : Check throttle position sensor system (Refer to Code No. P0120 P.13A-54).

STEP 4. Check throttle body (throttle valve portion) contamination.

Q: Is the check result normal?

YES : Replace engine-ECU <M/T> or engine-A/T-ECU <A/T>.

NO : Clean throttle body (throttle valve portion) (Refer to P.13A-398).

Inspection Procedure 15: Knocking

COMMENT ON TROUBLE SYMPTOM

- Failure is possibly caused by failed detonation control, improper thermal value of spark plug or other faults.

PROBABLE CAUSE

- Defective detonation sensor
- Failed detonation control system
- Failed ignition system
- Defective spark plug
- Failed engine-ECU <M/T>
- Failed engine-A/T-ECU <A/T>

DIAGNOSIS PROCEDURE

STEP 1. M.U.T.-II/III diagnosis code

Q: Diagnosis code set?

YES : Inspection chart for diagnosis code (Refer to P.13A-17).

NO : Go to Step 2 .

STEP 2. Connector check: B-104 and B-113 ignition coil connectors

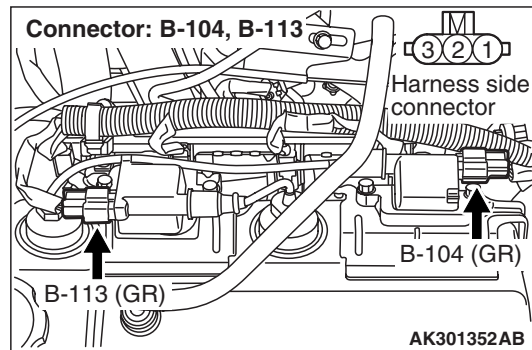

Q: Is the check result normal?

YES : Go to Step 3 .

NO : Repair or replace.

STEP 3. Check ignition secondary voltage waveform using an oscilloscope.

- Check ignition secondary voltage waveform (Refer to GROUP 16 –Ignition System –On-vehicle Service P.16-32).

Q: Is the check result normal?

YES : Check detonation sensor (Refer to Code No. P0325 P.13A-157).

NO : Go to Step 4 .

STEP 4. Check spark plug.

- Check spark plug (Refer to GROUP 16 –Ignition System –On-vehicle Service P.16-31).

Q: Is the check result normal?

YES : Go to Step 5 .

NO : Replace spark plug.

STEP 5. Check resistive cord itself.

- Check resistive cord itself (Refer to GROUP 16 – Ignition System –On-vehicle Service P.16-30).

Q: Is the check result normal?

YES : Go to Step 6 .

NO : Replace resistive cord.

STEP 6. Check ignition coil itself.

- Check ignition coil itself (Refer to GROUP 16 – Ignition System –On-vehicle Service P.16-30).

Q: Is the check result normal?

YES : Go to Step 7 .

NO : Replace ignition coil.

STEP 7. Check harness between ignition coil connector terminal No. 2 of each cylinder and body earth.

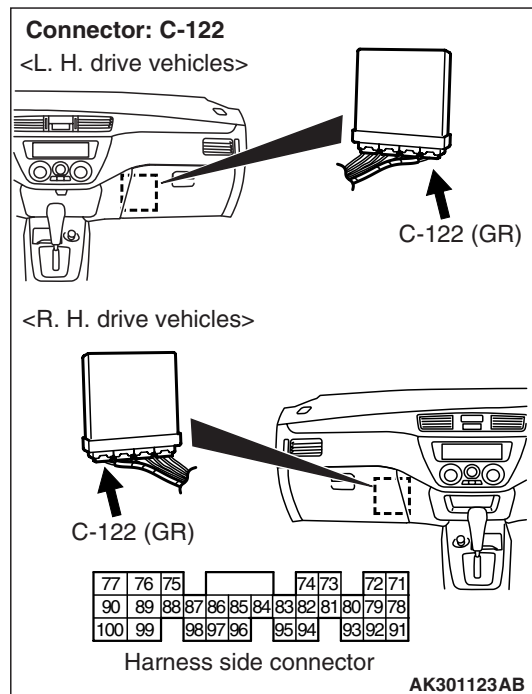
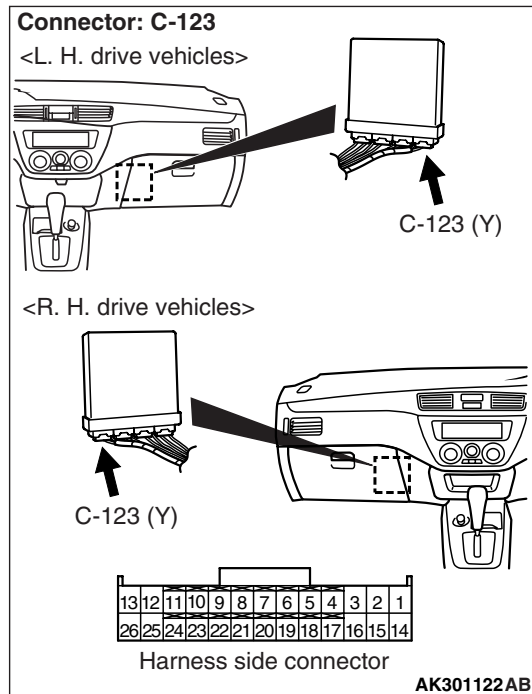
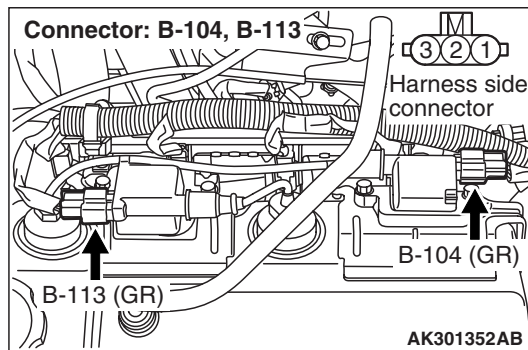

- Check earthing line for open circuit and damage.

Q: Is the check result normal?

YES : Check and repair harness between ignition coil connector terminal No. 3 of each cylinder and C-123 engine-ECU <M/T> or C-122 engine-A/T-ECU <A/T>.

- Check signal line for open circuit, short circuit and damage.

NO : Repair.

Inspection Procedure 16: Ignition Timing Offset

COMMENT ON TROUBLE SYMPTOM

- Failure is possibly caused by failed crank angle sensor, failed camshaft position sensor, improper installed timing belt or other faults.

PROBABLE CAUSE

- Failed crank angle sensor
- Failed camshaft position sensor
- Improperly installed timing belt
- Failed engine-ECU <M/T>
- Failed engine-A/T-ECU <A/T>

DIAGNOSIS PROCEDURE

STEP 1. M.U.T.-II/III diagnosis code

Q: Diagnosis code set?

YES : Inspection chart for diagnosis code (Refer to P.13A-17).

NO : Go to Step 2 .

STEP 2. Perform output wave pattern measurement of crank angle sensor and camshaft position sensor (Using oscilloscope).

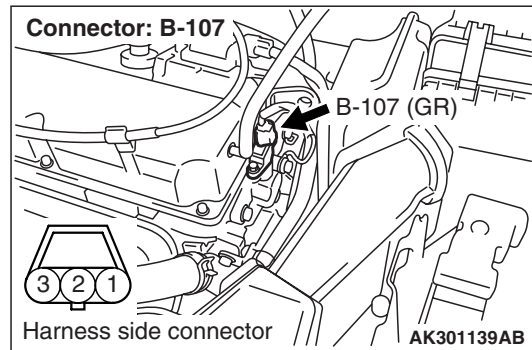
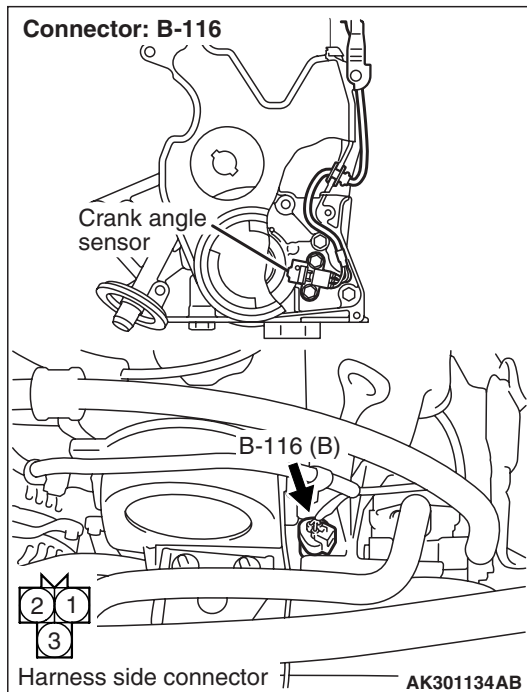

Crank Angle Sensor

- Use special tool test harness (MD998478) to connect B-116 crank angle sensor connector, and measure at pick-up harness.
- Engine: Idling
- Transmission: Neutral <M/T> or P range <A/T>
- Voltage between terminal No. 2 and earth.

Camshaft Position Sensor

- Use special tool test harness (MB991709) to connect B-107 camshaft position sensor connector, and measure at pick-up harness.
- Engine: Idling
- Transmission: Neutral <M/T> or P range <A/T>
- Voltage between terminal No. 2 and earth.

OK: Output waveform timings of both sensors are the same as the check procedure (Refer to P.13A-391) using an oscilloscope.

Q: Is the check result normal?

YES : Go to Step 3 .

NO : Go to Step 4 .

STEP 3. Check the trouble symptoms.

Q: Does trouble symptom persist?

YES : Replace engine-ECU <M/T> or engine-A/T-ECU <A/T>.

NO : Intermittent malfunction (Refer to GROUP 00 –How to Use Troubleshooting/Inspection Service Points P.00-5).

STEP 4. Check crank angle sensor and camshaft position sensor mounted conditions.

Q: Is the check result normal?

YES : Go to Step 5 .

NO : Repair.

STEP 5. Check timing marks of timing belt.**Q: Is the check result normal?****YES :** Go to Step 6 .**NO :** Align timing marks.**STEP 6. Check crank angle sensor vane.****Q: Is the check result normal?****YES :** Go to Step 7 .**NO :** Replace crank angle sensor vane.**STEP 7. Check camshaft position sensing cylinder.****Q: Is the check result normal?****YES :** Go to Step 8 .**NO :** Replace camshaft position sensing cylinder.**STEP 8. Replace crank angle sensor.**

- After replacing the crank angle sensor, re-check the trouble symptoms.

Q: Does trouble symptom persist?**YES :** Go to Step 9 .**NO :** Check end.**STEP 9. Replace camshaft position sensor.**

- After replacing the camshaft position sensor, re-check the trouble symptoms.

Q: Does trouble symptom persist?**YES :** Replace engine-ECU <M/T> or engine-A/T-ECU <A/T>.**NO :** Intermittent malfunction (Refer to GROUP 00 –How to Use Troubleshooting/Inspection Service Points [P.00-5](#)).**Inspection Procedure 17: Run on (Dieseling)****COMMENT ON TROUBLE SYMPTOM**

- Failure is possibly caused by leakage from injector.

PROBABLE CAUSE

- Failed injector
- Failed engine-ECU <M/T>
- Failed engine-A/T-ECU <A/T>

DIAGNOSIS PROCEDURE**STEP 1. Check injector for spray condition.**

- Check each injector for spray condition (Refer to [P.13A-407](#)).

Q: Does trouble symptom persist?**YES :** Replace engine-ECU <M/T> or engine-A/T-ECU <A/T>.**NO :** Replace injector.**Inspection Procedure 18: Odor, White Smoke, Black Smoke, and High-Concentration CO/HC during Idling****COMMENT ON TROUBLE SYMPTOM**

- Failure is possibly caused by improper air-fuel ratio, deteriorated catalyst, failed ignition system, failed fuel system, failed compression pressure or other faults.

PROBABLE CAUSE

- Incorrect air-fuel ratio
- Failed ignition system
- Failed fuel system
- Failed intake and exhaust system
- Failed emission control system
- Failed compression pressure

- Failed catalytic converter
- Failed engine-ECU <M/T>
- Failed engine-A/T-ECU <A/T>

DIAGNOSIS PROCEDURE**STEP 1. M.U.T.-II/III diagnosis code****Q: Diagnosis code set?****YES :** Inspection chart for diagnosis code (Refer to [P.13A-17](#)).**NO :** Go to Step 2 .

STEP 2. Check injector for operating sound.

- Check injector for operating sound (Refer to [P.13A-407](#)).

Q: Can operating sound be heard?

YES : Go to Step 3 .

NO : Check the injector system of the defective cylinder.

(Refer to [P.13A-115](#), Code P0201: No. 1 injector System)

(Refer to [P.13A-121](#), Code P0202: No. 2 injector System)

(Refer to [P.13A-127](#), Code P0203: No. 3 injector System)

(Refer to [P.13A-133](#), Code P0204: No. 4 injector System)

STEP 3. Check ignition timing.

- Check ignition timing. (Refer to GROUP 11A – On-vehicle Service [P.11A-10](#)).

Q: Is the check result normal?

YES : Go to Step 4 .

NO : Check for offset ignition timing (Refer to Inspection Procedure 16 [P.13A-305](#)).

STEP 4. M.U.T.-II/III data list

- Refer to data list reference table [P.13A-376](#).
 - a. Item 13: Intake air temperature sensor
 - b. Item 21: Engine coolant temperature sensor
 - c. Item 32: Manifold absolute pressure sensor

Q: Are the check results normal?

YES : Go to Step 5 .

NO : Perform the diagnosis code classified check Procedure for the sensor that has shown an abnormal data value (Refer to Inspection Chart for diagnosis codes [P.13A-17](#)).

STEP 5. Check air intake from intake hose and inlet manifold.**Q: Is the check result normal?**

YES : Go to Step 6 .

NO : Repair.

STEP 6. Check for emission leakage from exhaust manifold.**Q: Is the check result normal?**

YES : Go to Step 7 .

NO : Repair.

STEP 7. Check throttle body (throttle valve portion) for contamination.**Q: Is the check result normal?**

YES : Go to Step 8 .

NO : Clean throttle body (throttle valve portion) (Refer to [P.13A-398](#)).

STEP 8. M.U.T.-II/III data list

- Refer to data list reference table [P.13A-376](#).
 - a. Item 11: Oxygen sensor (front)

Q: Is the check result normal?

YES : Go to Step 9 .

NO : Check oxygen sensor (front) system (Refer to Code No. P0130 [P.13A-74](#)).

STEP 9. Check purge control solenoid valve itself.

- Check purge control solenoid valve itself (Refer to GROUP 17 –Emission Control System –Evaporative Emission Control System [P.17-11](#)).

Q: Is the check result normal?

YES : Go to Step 10 .

NO : Replace purge control solenoid valve.

STEP 10. Check EGR control solenoid valve itself.

- Check EGR control solenoid valve itself [Refer to GROUP 17 –Emission Control System – Exhaust Gas Recirculation (EGR) System [P.17-16](#)].

Q: Is the check result normal?

YES : Go to Step 11 .

NO : Replace EGR control solenoid valve.

STEP 11. Check EGR valve itself.

- Check EGR valve itself [Refer to GROUP 17 – Emission Control System – Exhaust Gas Recirculation (EGR) System [P.17-15](#)].

Q: Is the check result normal?

YES : Go to Step 12 .

NO : Replace EGR valve.

STEP 12. Fuel pressure measurement.

- Fuel pressure measurement (Refer to [P.13A-399](#)).

Q: Is the check result normal?

YES : Go to Step 13 .

NO : Repair.

STEP 13. Check positive crankcase ventilation valve itself.

- Check positive crankcase ventilation valve itself (Refer to GROUP 17 –Emission Control System – crankcase Emission Control System P.17-9).

Q: Is the check result normal?**YES :** Go to Step 14 .**NO :** Replace positive crankcase ventilation valve.**STEP 14. Check spark plug.**

- Check spark plug (Refer to GROUP 16 –Ignition System –On-vehicle Service P.16-31).

Q: Is the check result normal?**YES :** Go to Step 15 .**NO :** Replace spark plug.**STEP 15. Check resistive cord itself.**

- Check resistive cord itself (Refer to GROUP 16 – Ignition System –On-vehicle Service P.16-30).

Q: Is the check result normal?**YES :** Go to Step 16 .**NO :** Replace resistive cord.**STEP 16. Check ignition coil itself.**

- Check ignition coil itself (Refer to GROUP 16 – Ignition System –On-vehicle Service P.16-30).

Q: Is the check result normal?**YES :** Go to Step 17 .**NO :** Replace ignition coil.**STEP 17. Check compression pressure.**

- Check compression pressure (Refer to GROUP 11A –On-vehicle Service P.11A-12).

Q: Is the check result normal?**YES :** Go to Step 18 .**NO :** Repair.**STEP 18. Check injector for spraying condition.**

- Check each injector for spray condition (Refer to P.13A-407).

Q: Does trouble symptom persist?**YES :** Go to Step 19 .**NO :** Replace injector.**STEP 19. Replace catalytic converter.**

- After replacing the catalytic converter, re-check the trouble symptoms.

Q: Does trouble symptom persist?**YES :** Replace engine-ECU <M/T> or engine-A/T-ECU <A/T>.**NO :** Check end.**Inspection Procedure 19: Battery Rundown****COMMENT ON TROUBLE SYMPTOM**

- Failure is possibly caused by failed alternator, failed generation control circuit or other faults.

PROBABLE CAUSE

- Failed battery
- Alternator G terminal short-circuited
- Failed alternator
- Failed engine-ECU <M/T>
- Failed engine-A/T-ECU <A/T>

DIAGNOSIS PROCEDURE**NOTE:****1: L.H. drive vehicles***2: R.H. drive vehicles***STEP 1. Check battery voltage.**

- Measure battery voltage during cranking.

OK: 8 V or more**Q: Is the check result normal?****YES :** Go to Step 2 .**NO :** Check battery (Refer to GROUP 54A – Battery –On-vehicle Service –Battery test P.54A-5).

STEP 2. Connector check: B-18 intermediate connector

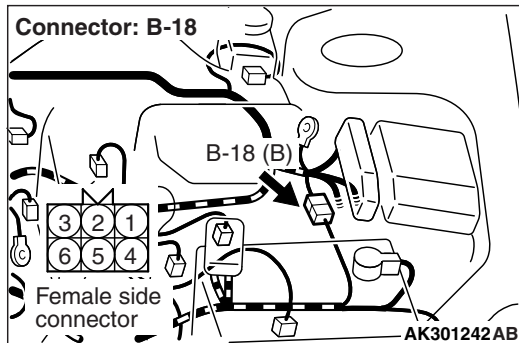

Q: Is the check result normal?

YES : Go to Step 3 .

NO : Repair or replace.

STEP 3. Perform voltage measurement at B-18 intermediate connector.

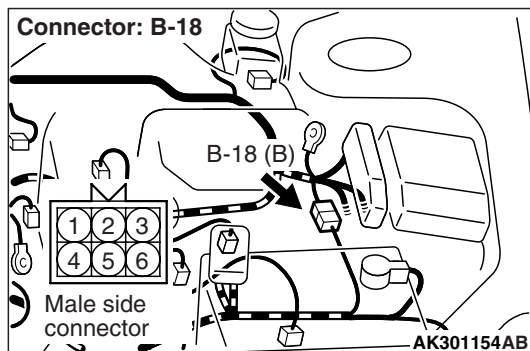

- Disconnect connector, and measure at male connector side.
- Ignition switch: ON
- Voltage between terminal No. 5 and earth.

OK: System voltage

Q: Is the check result normal?

YES : Go to Step 5 .

NO : Go to Step 4 .

STEP 4. Connector check: C-201 ignition switch connector

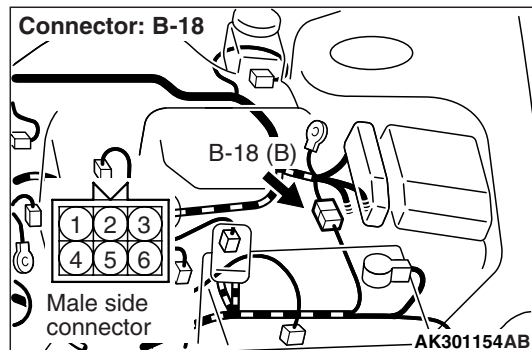
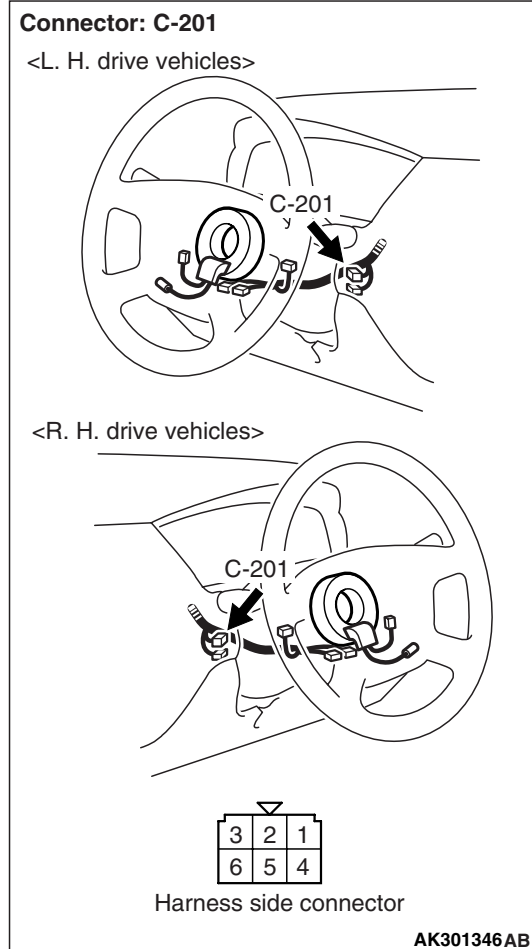

Q: Is the check result normal?

YES : Check intermediate connectors C-04, C-13^{*1}, C-137^{*2}, C-03^{*1}, C-212 and C-210, and repair if necessary. If intermediate connectors are normal, check and repair harness between B-18 (terminal No. 5) intermediate connector and C-201 (terminal No. 2) ignition switch connector.

- Check power supply line for open/short circuit.

NO : Repair or replace.

STEP 5. Perform voltage measurement at B-18 intermediate connector.

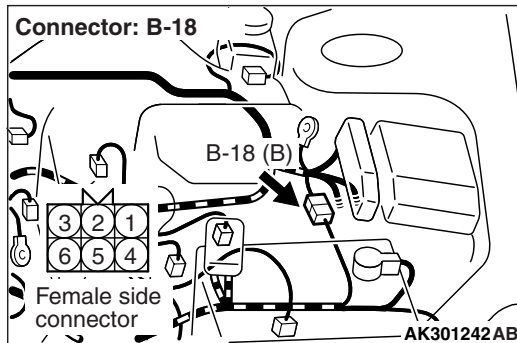

- Disconnect connector, and measure at female connector side.
- Ignition switch: ON
- Voltage between terminal No. 4 and earth.

OK: System voltage

Q: Is the check result normal?

YES : Go to Step 10 .

NO : Go to Step 6 .

STEP 6. Connector check: B-26 alternator connector

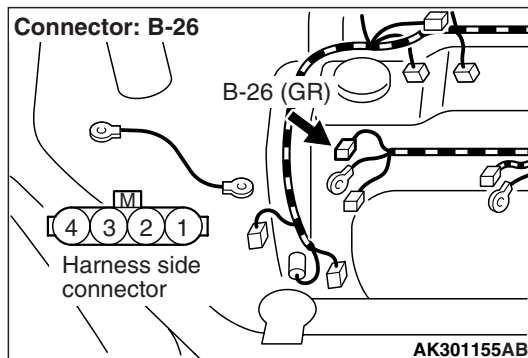

Q: Is the check result normal?

YES : Go to Step 7 .

NO : Repair or replace.

STEP 7. Check harness between B-18 (terminal No. 4) intermediate connector and B-26 (terminal No. 1) alternator connector.

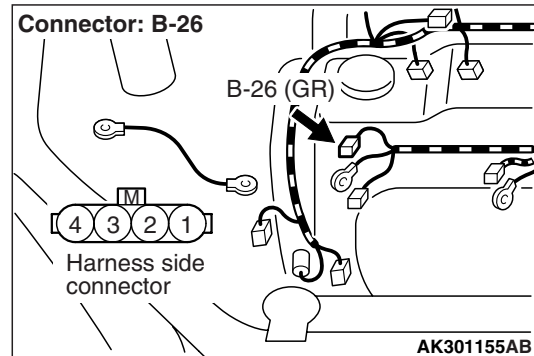
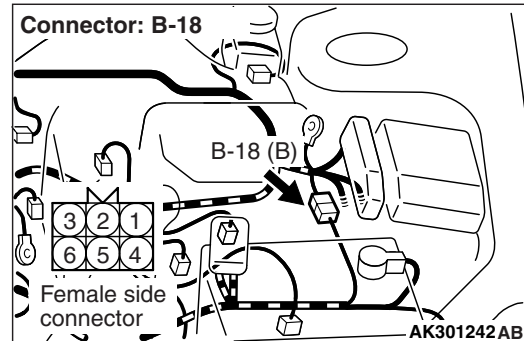

- Check output line for short circuit.

Q: Is the check result normal?

YES : Go to Step 8 .

NO : Repair.

STEP 8. Check harness between B-18 (terminal No. 5) intermediate connector and B-26 (terminal No. 3) alternator connector.

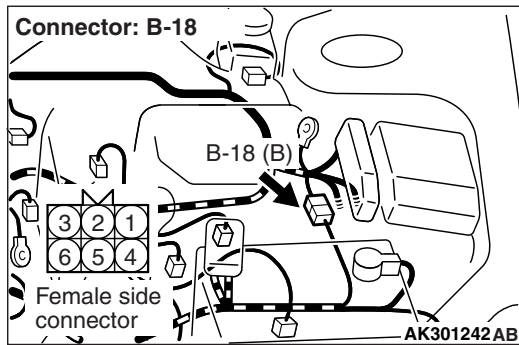

STEP 9. Check harness between B-26 (terminal No. 3) alternator connector and C-201 (terminal No. 2) ignition switch connector.

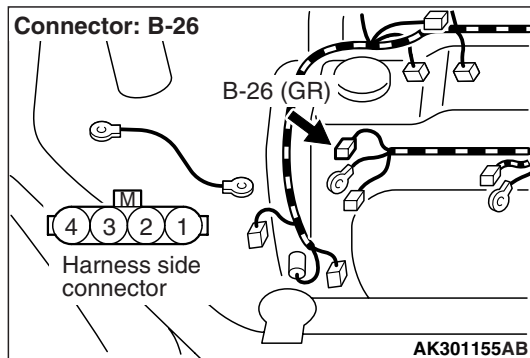
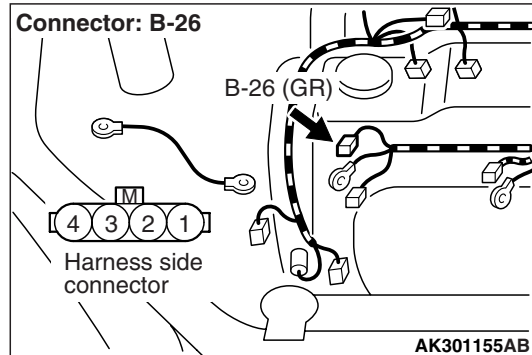

- Check power supply line for open/short circuit.

Q: Is the check result normal?

YES : Go to Step 9 .

NO : Repair.



NOTE: Before checking harness, check intermediate connectors C-04, C-13*¹, C-137*², C-03*¹, C-212 and C-210 and repair if necessary.

- Check power supply line for damage.

Q: Is the check result normal?

YES : Replace alternator.

NO : Repair.

STEP 10. Connector check: C-125 engine-ECU <M/T> connector or C-122 engine-A/T-ECU <A/T> connector

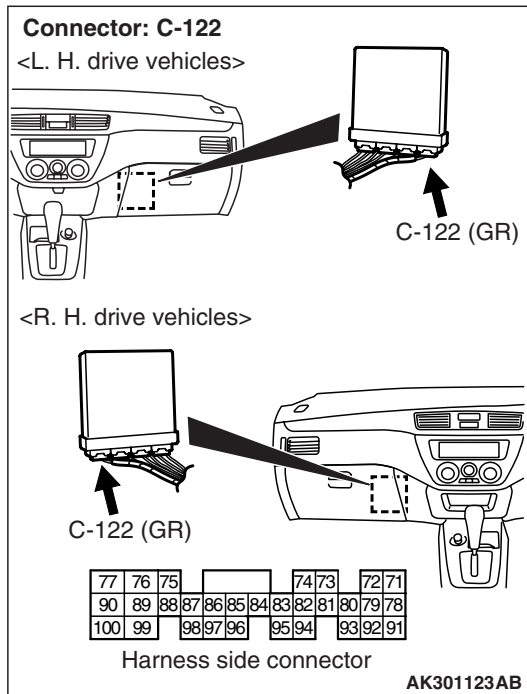
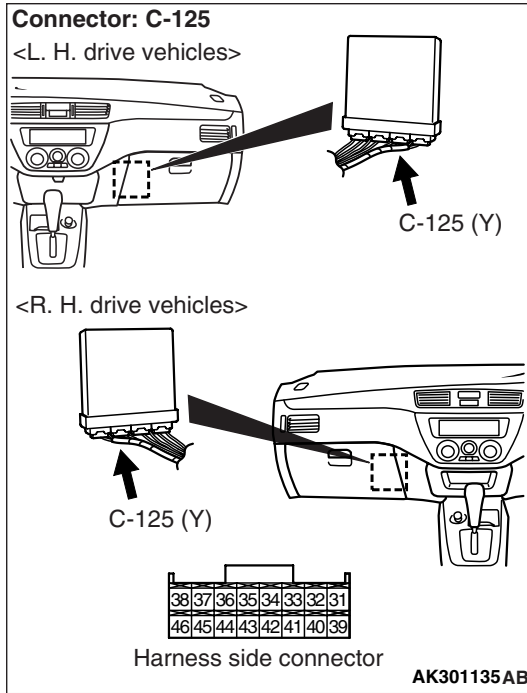

Q: Is the check result normal?

YES : Go to Step 11 .

NO : Repair or replace.

STEP 11. Perform voltage measurement at C-125 engine-ECU <M/T> connector or C-122 engine-A/T-ECU <A/T> connector.

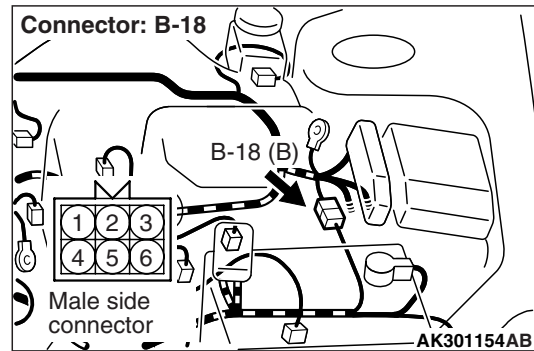
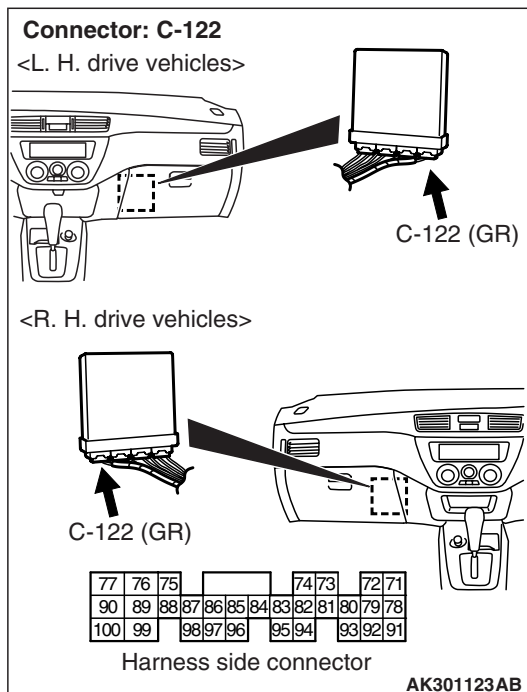
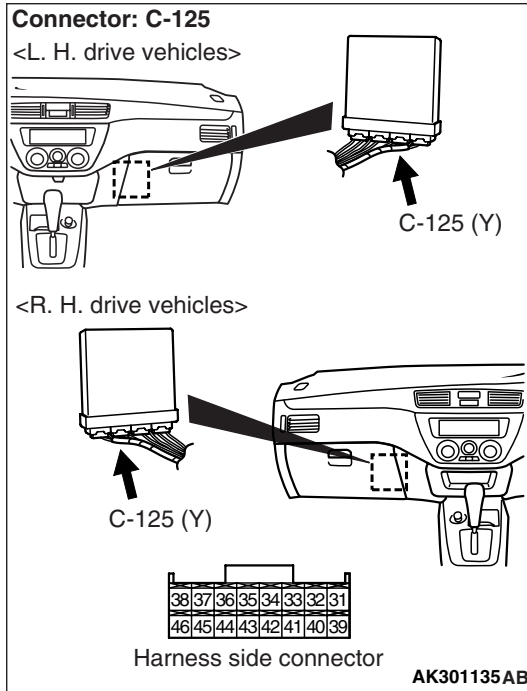

- Disconnect connector, and measure at harness side.
- Ignition switch: ON
- Voltage between terminal No. 33 <M/T> or terminal No. 8 <A/T> and earth.

OK: System voltage

Q: Is the check result normal?

YES : Go to Step 12 .

NO : Check and repair harness between B-18 (terminal No. 4) intermediate connector and C-125 (terminal No. 33) engine-ECU <M/T> connector or C-122 (terminal No. 8) engine-A/T-ECU <A/T> connector.

- Check output line for short circuit.

STEP 12. Perform voltage measurement at C-125 engine-ECU <M/T> connector or C-122 engine-A/T-ECU <A/T> connector.

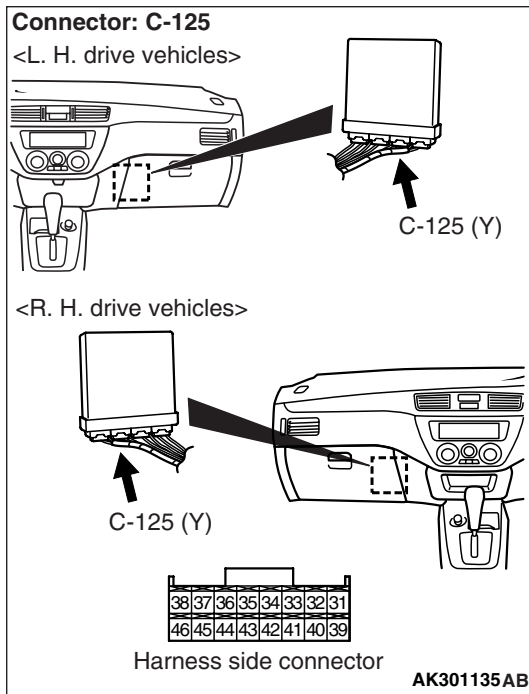

OK: Switching the headlamps to ON from OFF causes the voltage to increase by 0.2 – 3.5 V.

Q: Is the check result normal?

YES : Go to Step 13 .
NO : Check alternator.

STEP 13. Check the trouble symptoms.

Q: Does trouble symptom persist?

YES : Replace engine-ECU <M/T> or engine-A/T-ECU <A/T>.

NO : Intermittent malfunction (Refer to GROUP 00 –How to Use Troubleshooting/Inspection Service Points P.00-5).

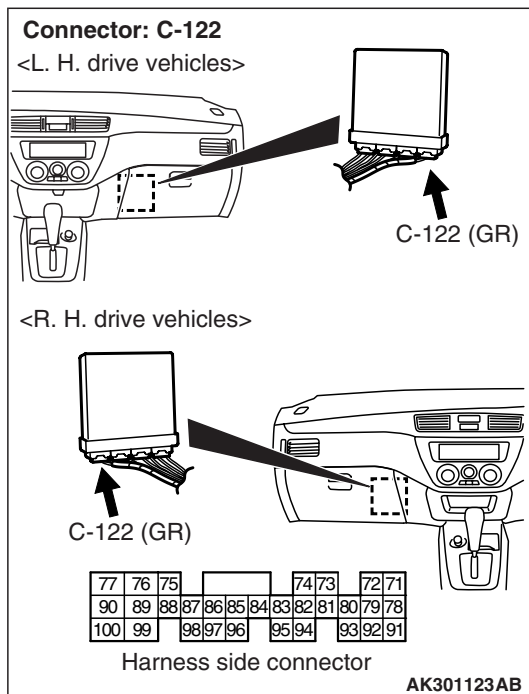

- Measure engine-ECU <M/T> or engine-A/T-ECU <A/T> terminal voltage.
- Engine: Idling after warm-up
- Transmission: Neutral <M/T> or P range <A/T>
- Radiator fan: Inactive
- Voltage between terminal No. 33 <M/T> or terminal No. 8 <A/T> and earth.

Inspection Procedure 20: Overheating

COMMENT ON TROUBLE SYMPTOM

- Failure is possibly caused by failed engine cooling system, failed fan controller, failed engine coolant temperature sensor or other faults.

PROBABLE CAUSE

- Insufficient or deteriorated engine coolant
- Failed fan controller
- Failed engine coolant temperature sensor
- Failed thermostat
- Failed water pump
- Failed radiator core
- Failed engine-ECU <M/T>
- Failed engine-A/T-ECU <A/T>

DIAGNOSIS PROCEDURE

STEP 1. M.U.T.-II/III diagnosis code

Q: Diagnosis code set?

YES : Inspection chart for diagnosis code (Refer to [P.13A-17](#)).

NO : Go to Step 2 .

STEP 2. Check engine coolant.

NOTE: If engine coolant level falls too early, check for leaky spots, and repair if necessary.

- Check engine coolant (Refer to GROUP 14 – On-vehicle Service [P.14-21](#)).

Q: Is the check result normal?

YES : Go to Step 3 .

NO : Replace or add engine coolant.

STEP 3. M.U.T.-II/III actuator test

- Refer to actuator test reference table [P.13A-383](#).

a. Item 21: Fan controller

OK: Fan motor rotating

Q: Is the check result normal?

YES : Go to Step 4 .

NO : Check fan control relay system (Refer to Inspection Procedure 25 [P.13A-344](#)).

STEP 4. M.U.T.-II data list

- Refer to data list reference table [P.13A-376](#).
a. Item 21: Engine coolant temperature sensor

OK:

Engine cold state: At ambient temperature or equivalent.

Engine hot state: At 80 –120° C

Q: Is the check result normal?

YES : Go to Step 5 .

NO : Check engine coolant temperature sensor system (Refer to Code No. P0115 [P.13A-43](#)).

STEP 5. Check thermostat.

- Check thermostat (Refer to GROUP 14 –Thermostat [P.14-26](#)).

Q: Is the check result normal?

YES : Go to Step 6 .

NO : Replace thermostat.

STEP 6. Check water pump.

- Check water pump.

Q: Is the check result normal?

YES : Replace radiator.

NO : Replace water pump.

Inspection Procedure 21: Abnormal Rotation of Fan Motor

Fan controller (radiator fan, A/C condenser fan) circuit

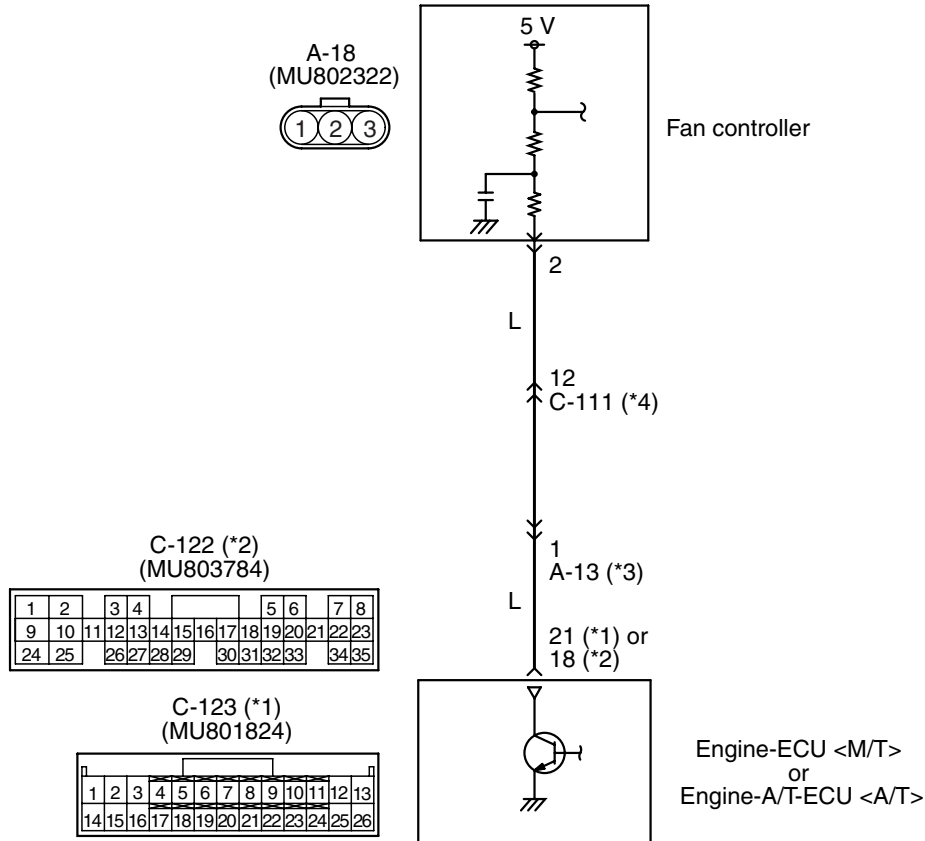

NOTE

- *1: M/T
- *2: A/T
- *3: L.H. drive vehicles
- *4: R.H. drive vehicles

Wire colour code

B: Black LG: Light green G: Green L: Blue W: White Y: Yellow SB: Sky blue BR: Brown O: Orange GR: Grey
R: Red P: Pink V: Violet

AK401362 AB

OPERATION

- The control (duty) signal is inputted to the fan controller (terminal No. 2) from the engine-ECU (terminal No. 21) <M/T> or engine-A/T-ECU (terminal No. 18) <A/T>.

FUNCTION

- The engine-ECU <M/T> or engine-A/T-ECU <A/T> inputs a duty signal suitable for the engine coolant temperature, vehicle speed and A/C switch position to the fan controller. In response to the signal, the fan controller controls the rotating speeds of the radiator fan and A/C condenser fan (The fan speed becomes higher as the average voltage of the terminal comes nearer to 5V).

PROBABLE CAUSE

- Failed fan controller
- Open/short circuit in fan controller circuit or loose connector contact
- Failed engine-ECU <M/T>
- Failed engine-A/T-ECU <A/T>

DIAGNOSIS PROCEDURE

NOTE:

- *1: L.H. drive vehicles
- *2: R.H. drive vehicles

STEP 1. Connector check: C-123 engine-ECU <M/T> connector or C-122 engine-A/T-ECU <A/T> connector

STEP 2. Check at C-123 engine-ECU <M/T> connector or C-122 engine-A/T-ECU <A/T> connector.

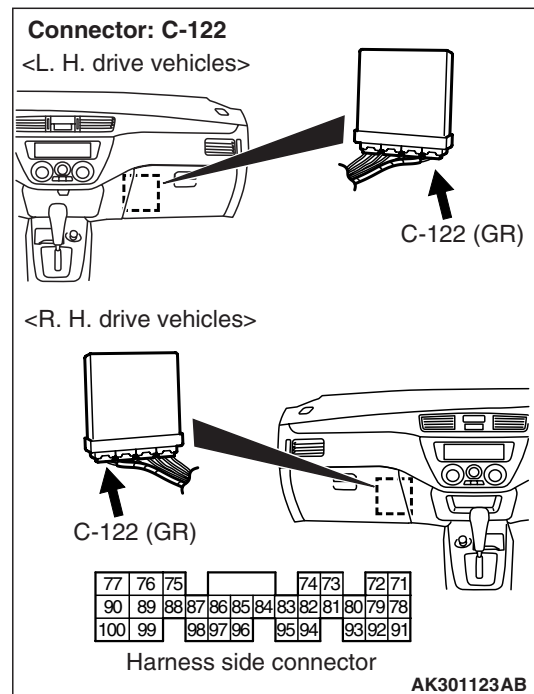
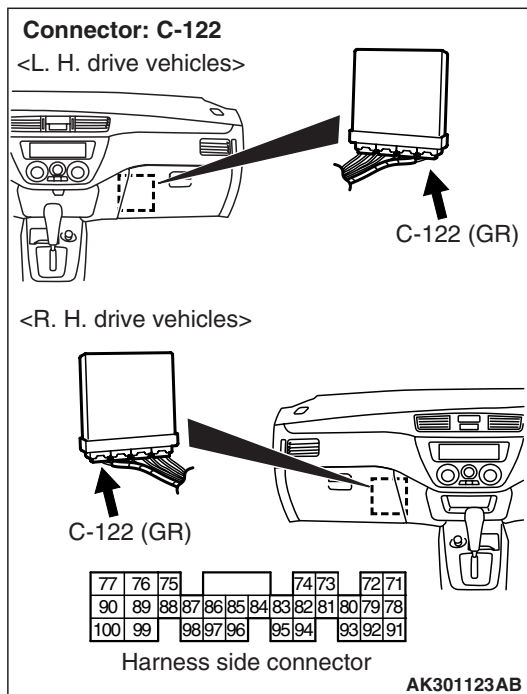
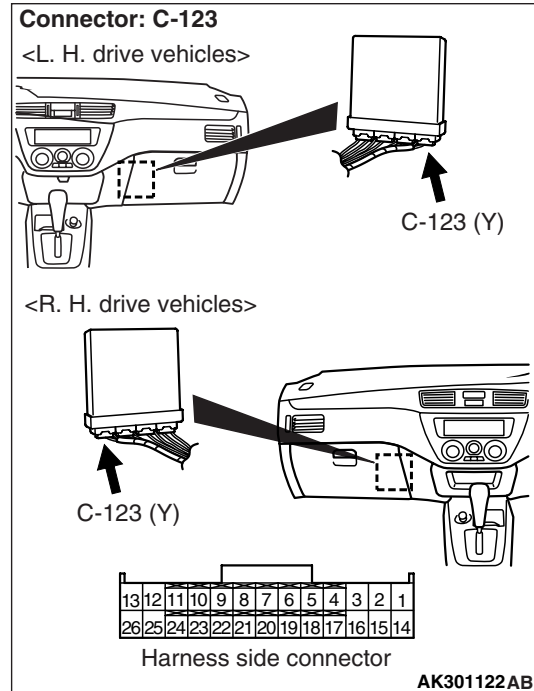
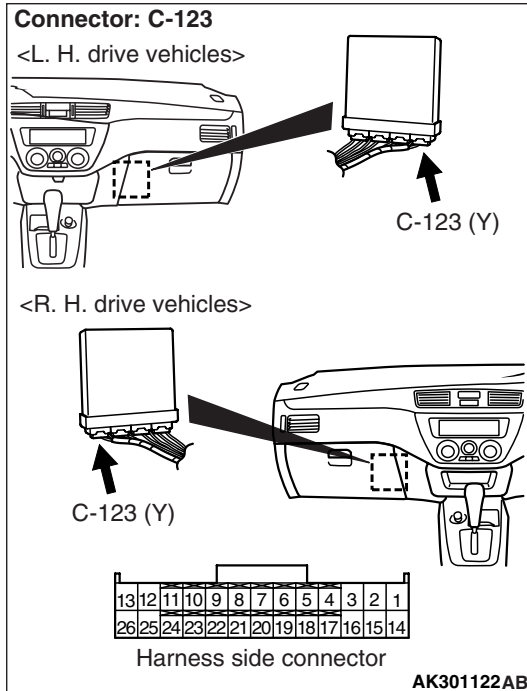

Q: Is the check result normal?
YES : Go to Step 2 .
NO : Repair or replace.

- Disconnect connector, and measure at harness side.
- Ignition switch: ON
- Short-circuit terminal No. 21 <M/T> or terminal No. 18 <A/T> to earth.

OK: Fan motor stops rotating.

Q: Is the check result normal?
YES : Go to Step 3 .
NO : Go to Step 4 .

STEP 3. Check the trouble symptoms.

Q: Does trouble symptom persist?

YES : Replace engine-ECU <M/T> or engine-A/T-ECU <A/T>.

NO : Intermittent malfunction (Refer to GROUP 00 –How to Use Troubleshooting/Inspection Service Points P.00-5).

STEP 4. Perform voltage measurement at C-123 engine-ECU <M/T> connector or C-122 engine-A/T-ECU <A/T> connector.

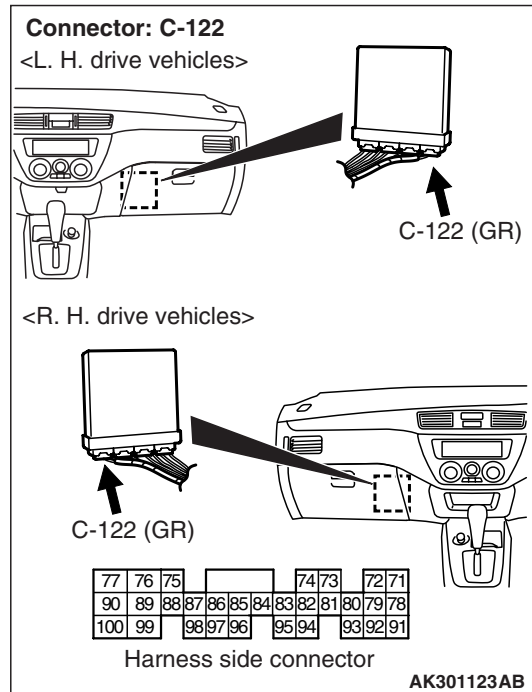
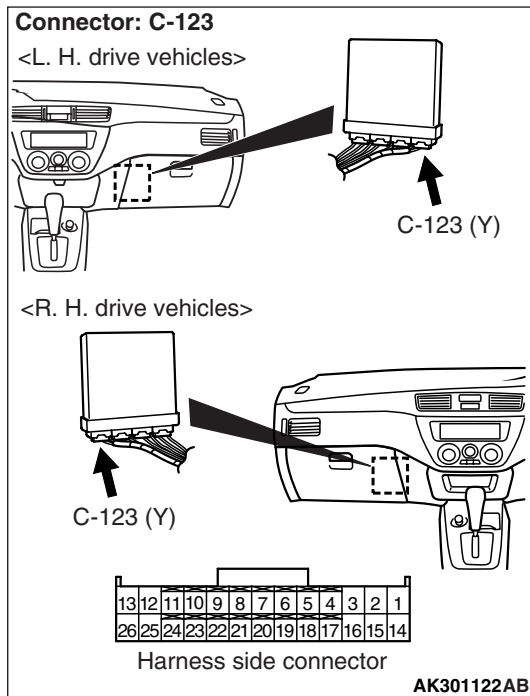

- Disconnect connector, and measure at harness side.
 - Ignition switch: ON
 - Voltage between terminal No. 21 <M/T> or terminal No. 18 <A/T> and earth.
- OK: 4.9 – 5.1 V**

Q: Is the check result normal?
YES : Replace fan controller.
NO : Go to Step 5 .

STEP 5. Connector check: A-18 fan controller connector

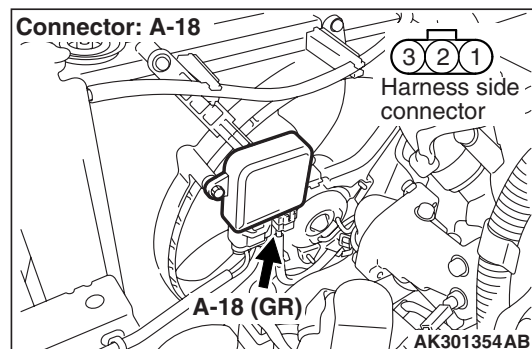

Q: Is the check result normal?
YES : Go to Step 6 .
NO : Repair or replace.

STEP 6. Check harness between A-18 (terminal No. 2) fan controller connector and C-123 (terminal No. 21) engine-ECU <M/T> connector or C-122 (terminal No. 8) engine-A/T-ECU <A/T> connector.

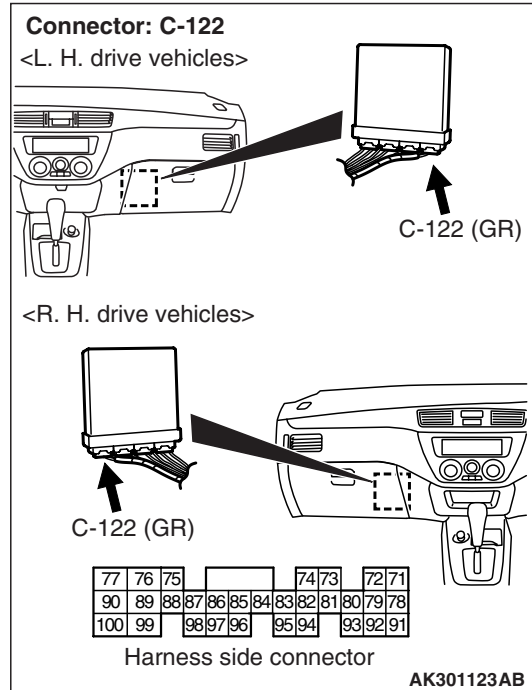
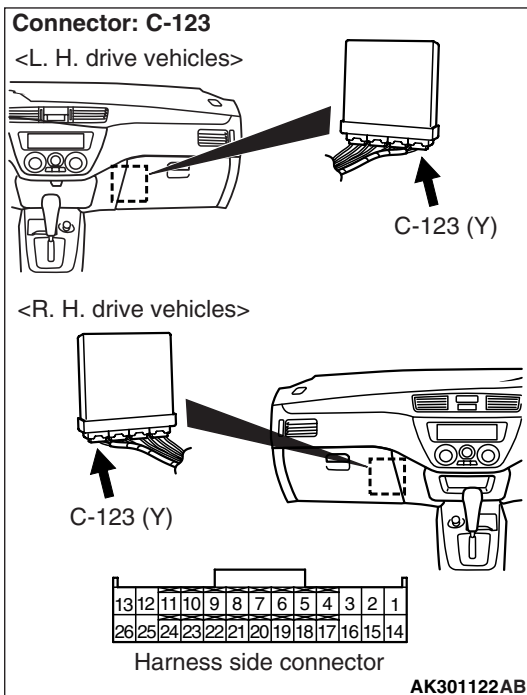
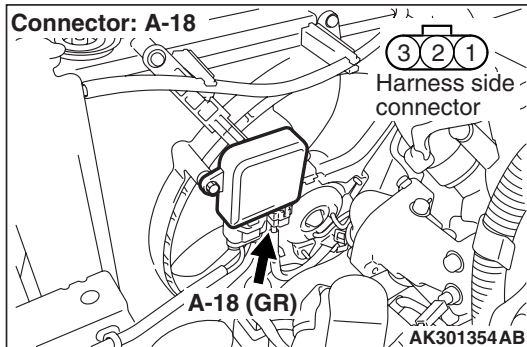

NOTE: Before checking harness, check intermediate connector A-13*¹, C-111*², and repair if necessary.

- Check output line for open circuit.

Q: Is the check result normal?

- YES :** Replace fan controller.
- NO :** Repair.

Inspection Procedure 22: Poor A/C Performance

COMMENT ON TROUBLE SYMPTOM

- Failure is possibly caused by short /overcharged A/C refrigerant, failed A/C control system, failed fan control system or other faults.

PROBABLE CAUSE

- Short or overcharged A/C refrigerant
- Failed A/C compressor relay
- Failed fan controller
- Failed A/C-ECU
- Failed engine-ECU <M/T>
- Failed engine-A/T-ECU <A/T>

DIAGNOSIS PROCEDURE

STEP 1. M.U.T.-II/III diagnosis code

Q: Diagnosis code set?

- YES :** Inspection chart for diagnosis code (Refer to P.13A-17).
- NO :** Go to Step 2 .

STEP 2. A/C compressor magnet clutch operation check.

- Engine: Idling
- A/C set temperature:
Maximum Cool when temperature in cabin is 25° C or more
Maximum Hot when temperature in cabin is 25° C or less

OK:**Magnet clutch active (when A/C is ON)****Magnet clutch inactive (when A/C is OFF)****Q: Is the check result normal?****YES :** Go to Step 5 .**NO :** Go to Step 3 .**STEP 3. M.U.T.-II/III data list**

- Refer to data list reference table [P.13A-376](#).
 - a. Item 28: A/C switch
 - Engine: Idling
 - A/C set temperature:
Maximum Cool when temperature in cabin is 25° C or more
Maximum Hot when temperature in cabin is 25° C or less

OK:**ON (when A/C is ON)****OFF (when A/C is OFF)****Q: Is the check result normal?****YES :** Go to Step 4 .**NO :** Check A/C switch (Refer to Inspection Procedure 26 [P.13A-352](#)).**STEP 4. M.U.T.-II/III data list**

- Refer to data list reference table [P.13A-376](#).
 - a. Item 49: A/C relay
 - Engine: Running at idle
 - A/C set temperature:
Maximum Cool when temperature in cabin is 25° C or more.
Maximum Hot when temperature in cabin is 25° C or less.

OK:**ON (when A/C is ON)****OFF (when A/C is OFF)****Q: Is the check result normal?****YES :** Check Air conditioner (Refer to GROUP 55A –Troubleshooting [P.55A-5](#)).**NO :** Check A/C system (Refer to inspection procedure 26 [P.13A-352](#)).**STEP 5. Check charged amount of A/C refrigerant.**

- Check charged amount of A/C refrigerant (Refer to GROUP 55A –On-vehicle Service [P.55A-70](#)).

Q: Is the check result normal?**YES :** Go to Step 6 .**NO :** Adjust charged amount of A/C refrigerant.**STEP 6. M.U.T.-II/III actuator test**

- Refer to actuator test reference table [P.13A-383](#).
 - a. Item 21: Fan controller

OK: Fan motor rotates.**Q: Is the check result normal?****YES :** Check A/C load signal system (Refer to Inspection Procedure 27 [P.13A-355](#)).**NO :** Check fan control relay system (Refer to Inspection Procedure 25 [P.13A-344](#)).

Inspection Procedure 23: Engine-ECU<M/T> or Engine-A/T-ECU<A/T> Power Supply, Engine Control Relay, Ignition Switch-IG1 System

Power supply and ignition switch-IG circuit

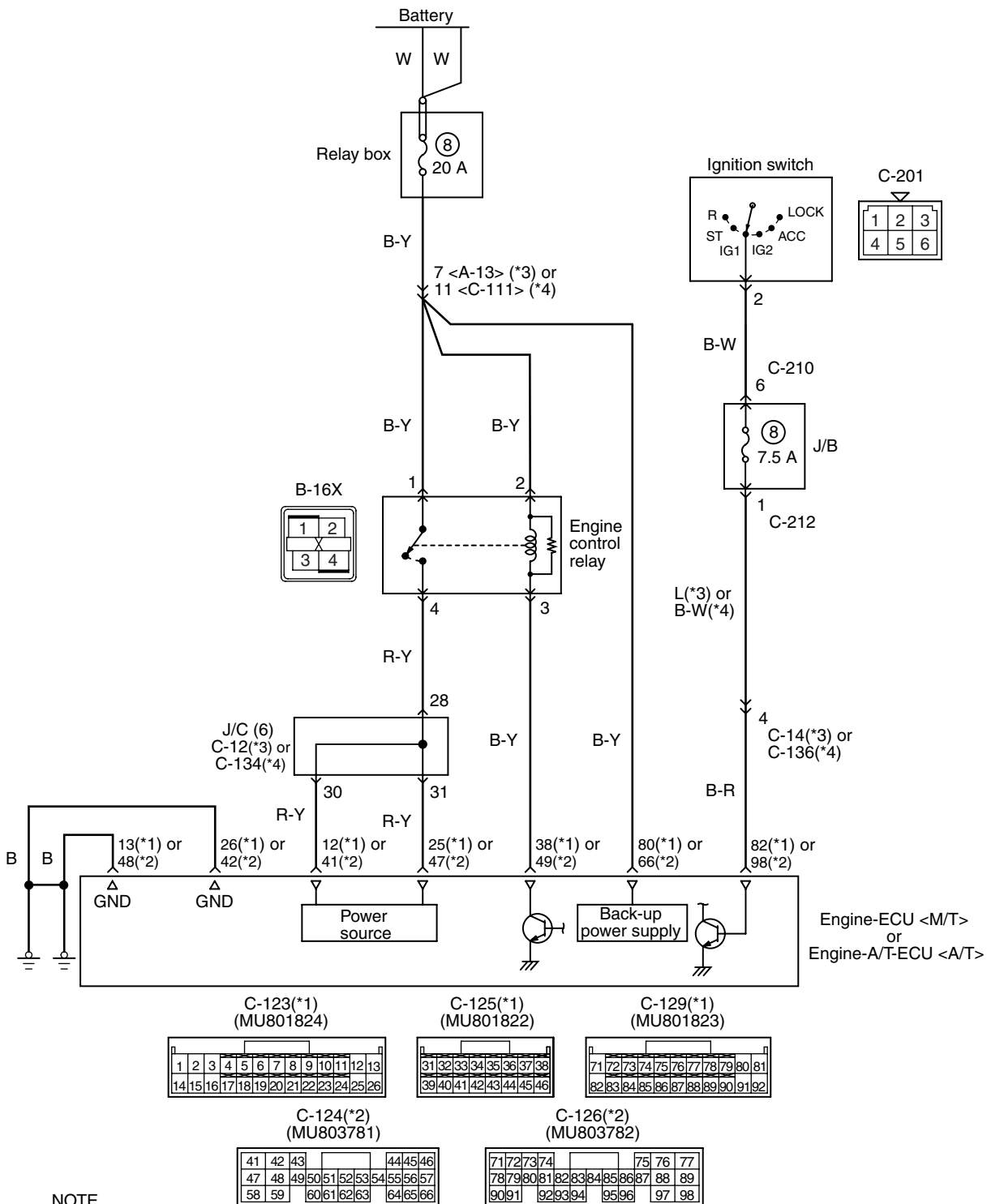

OPERATION

- The battery voltage is applied to the engine control relay (terminal No. 1 and 2).
- The engine-ECU (terminal No. 38) <M/T> or engine-A/T-ECU (terminal No. 49) <A/T> makes the power transistor in the unit be in "ON" position and makes currents go on the engine control relay coil, and that makes the relay be in "ON" position.
- When the engine control relay is in "ON" position, the battery voltage is supplied to the engine-ECU <M/T> or engine-A/T-ECU <A/T>, the sensor and the actuator from the engine control relay (terminal No. 1).
- The engine-ECU (terminal No. 13, No. 26) or engine-A/T-ECU (terminal No. 42, No. 48) is grounded to the vehicle body.

FUNCTION

- When the ignition switch ON signal is input to the engine-ECU <M/T> or engine-A/T-ECU <A/T>, the engine-ECU <M/T> or engine-A/T-ECU <A/T> places the engine control relay in the ON position. Accordingly, the battery voltage is supplied to the engine-ECU <M/T> or engine-A/T-ECU <A/T>, sensor and actuator.

PROBABLE CAUSE

- Failed engine control relay
- Open/short circuit in engine control relay circuit or loose connector contact
- Failed engine-ECU <M/T>
- Failed engine-A/T-ECU <A/T>

DIAGNOSIS PROCEDURE**NOTE:**

*1: L.H. drive vehicles

*2: R.H. drive vehicles

STEP 1. Check battery voltage.

- Measure battery voltage during cranking.

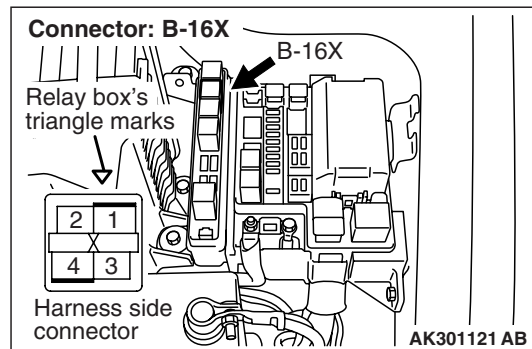
OK: 8 V or more**Q: Is the check result normal?****YES :** Go to Step 2 .**NO :** Check battery (Refer to GROUP 54A – Battery –On-vehicle Service –Battery test P.54A-5).**STEP 2. Connector check: B-16X engine control relay connector****Q: Is the check result normal?****YES :** Go to Step 3 .**NO :** Repair or replace.**STEP 3. Check engine control relay.**

- Check engine control relay (Refer to P.13A-404).

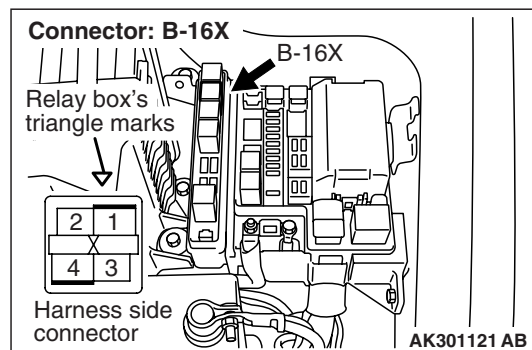
Q: Is the check result normal?**YES :** Go to Step 4 .**NO :** Replace engine control relay.**STEP 4. Perform voltage measurement at B-16X engine control relay connector.**

- Remove relay, and measure at relay box side.
- Voltage between terminal No. 1 and earth, also between terminal No. 2 and earth.

OK: System voltage**Q: Is the check result normal?****YES :** Go to Step 5 .**NO :** Check intermediate connector A-13*1, C-111*2, and repair if necessary. If intermediate connector is normal, check and repair harness between B-16X (terminal No. 1) engine control relay connector and battery.

- Check power supply line for open/short circuit.

STEP 5. Connector check: C-129 engine-ECU <M/T> connector or C-126 engine-A/T-ECU <A/T> connector.

STEP 6. Perform voltage measurement at C-129 engine-ECU <M/T> connector or C-126 engine-A/T-ECU <A/T> connector

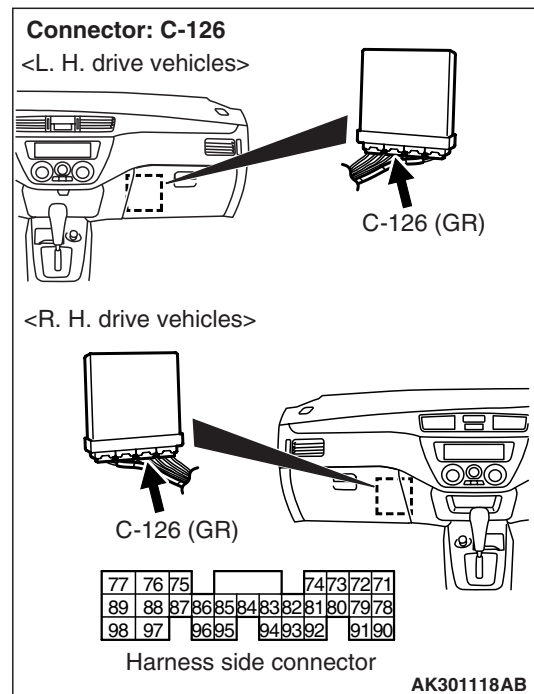
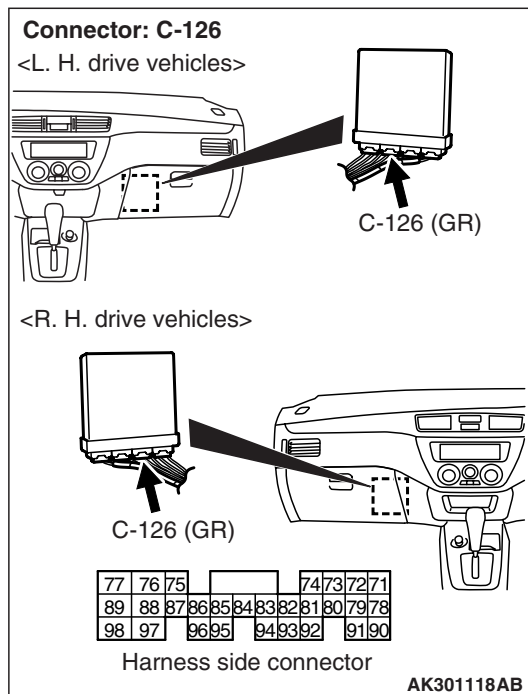
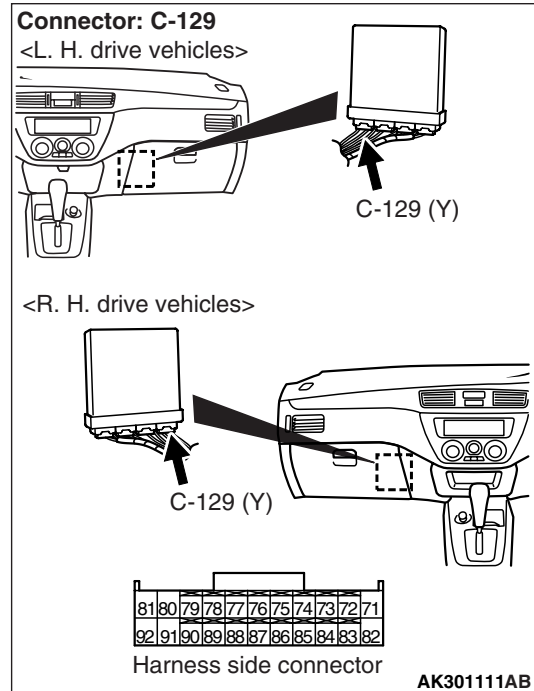
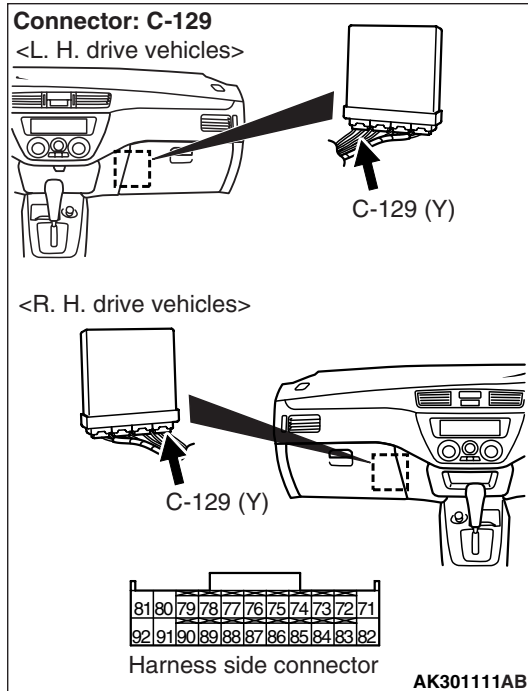

Q: Is the check result normal?

YES : Go to Step 6 .

NO : Repair or replace.

- Disconnect connector, and measure at harness side.
- Ignition switch: ON
- Voltage between terminal No. 82 <M/T> or terminal No. 98 <A/T> and earth.

OK: System voltage

Q: Is the check result normal?

YES : Go to Step 9 .

NO : Go to Step 7 .

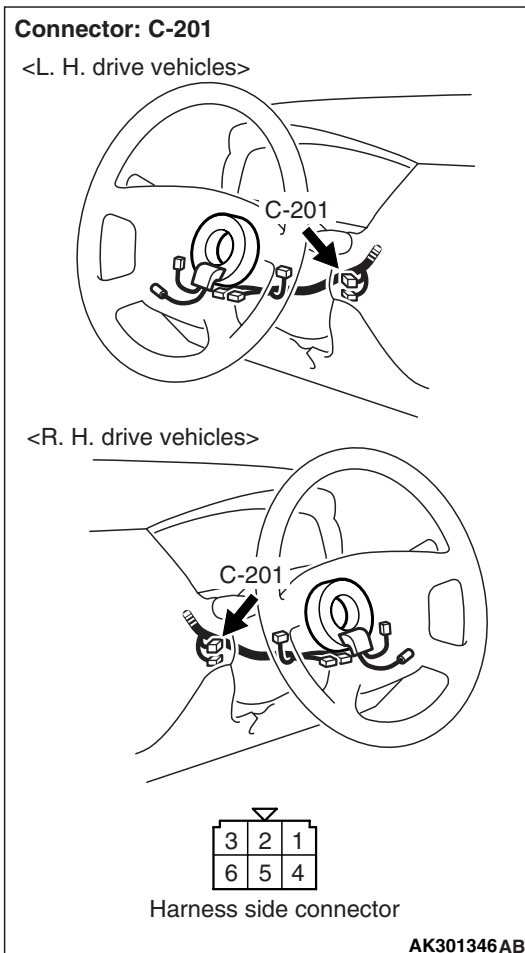
STEP 7. Connector check: C-201 ignition switch connector

Q: Is the check result normal?

YES : Go to Step 8 .

NO : Repair or replace.

STEP 8. Check ignition switch.

Connector: C-201

<L. H. drive vehicles>

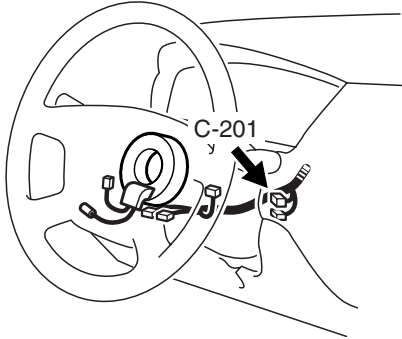

<R. H. drive vehicles>

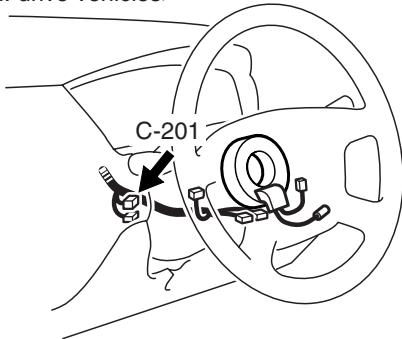

3	2	1
6	5	4

Harness side connector

AK301346AB

Connector: C-129

<L. H. drive vehicles>

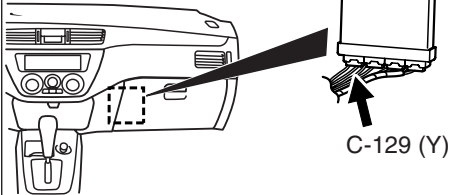

<R. H. drive vehicles>

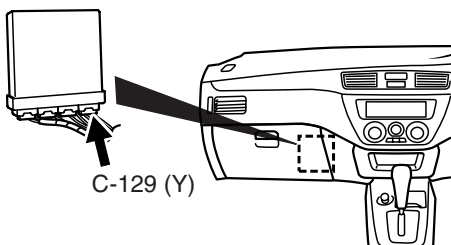

81	80	79	78	77	76	75	74	73	72	71
92	91	90	89	88	87	86	85	84	83	82

Harness side connector

AK301111AB

Connector: C-126

<L. H. drive vehicles>

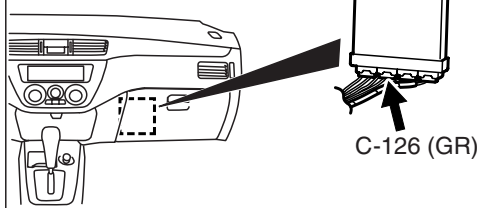

<R. H. drive vehicles>

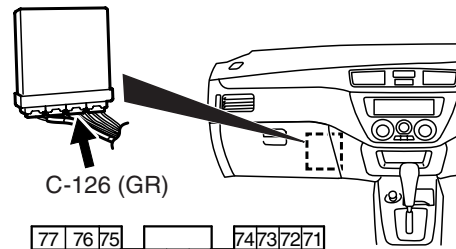

77	76	75				74	73	72	71
89	88	87	86	85	84	83	82	81	80
98	97		96	95		94	93	92	91

Harness side connector

AK301118AB

- Check ignition switch (Refer to GROUP 54A – Ignition Switch – Ignition Switch P.54A-31).

Q: Is the check result normal?

- YES :**
- Check intermediate connectors C-14*¹, C-136*², C-210 and C-212 and repair if necessary. If intermediate connectors are normal, check and repair harness between C-129 (terminal No. 82) engine-ECU <M/T> connector or C-126 (terminal No. 98) engine-A/T-ECU <A/T> connector and C-201 (terminal No. 2) ignition switch connector.
 - Check power supply line for open/short circuit.

NO : Replace ignition switch.

STEP 9. Perform voltage measurement at C-129 engine-ECU <M/T> connector or C-124 engine-A/T-ECU <A/T> connector.

Q: Is the check result normal?

YES : Go to Step 10 .

- NO :**
- Check intermediate connector A-13^{*1}, C-111^{*2} and repair if necessary. If intermediate connector is normal, check and repair harness between C-129 (terminal No. 80) engine-ECU <M/T> connector or C-124 (terminal No. 66) engine-A/T-ECU <A/T> connector and battery.
 - Check power supply line for short circuit.

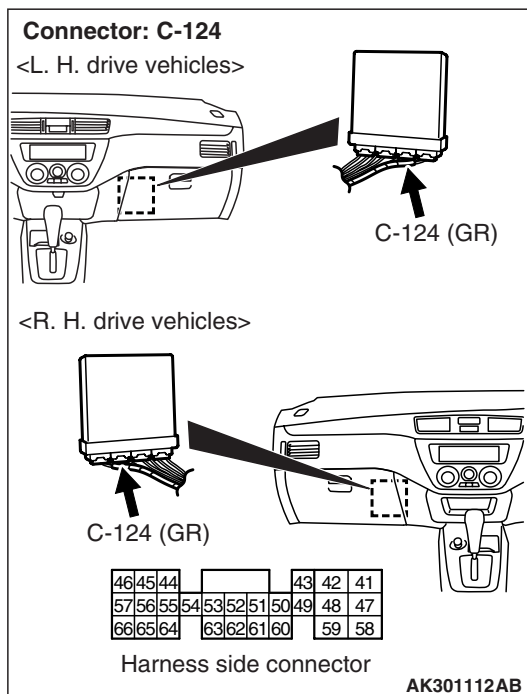
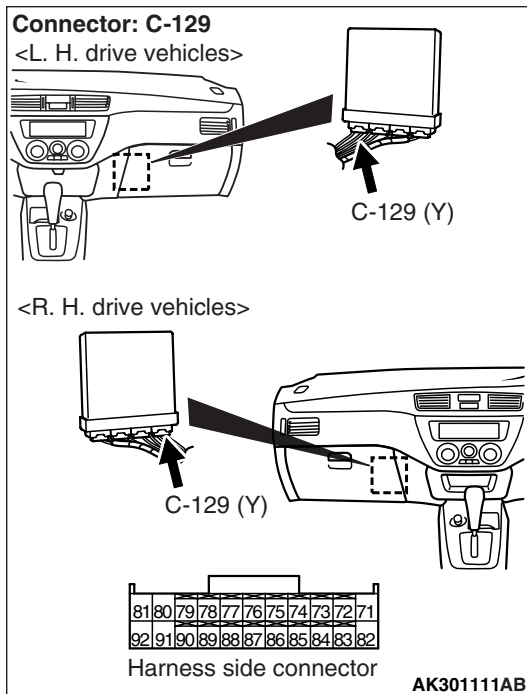

- Disconnect connector, and measure at harness side.
- Ignition switch: ON
- Voltage between terminal No. 80 <M/T> or terminal No. 66 <A/T> and earth.

OK: System voltage

STEP 10. Connector check: C-123 engine-ECU <M/T> connector or C-124 engine-A/T-ECU <A/T> connector

STEP 11. Perform resistance measurement at C-123 engine-ECU <M/T> or C-124 engine-A/T-ECU <A/T> connector.

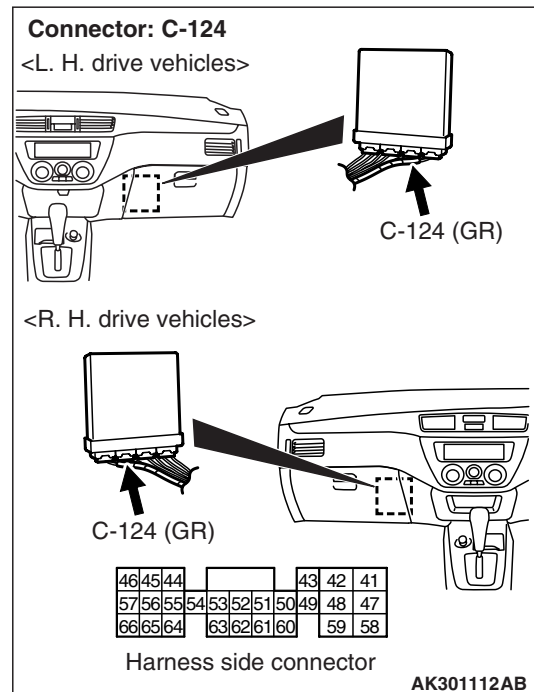
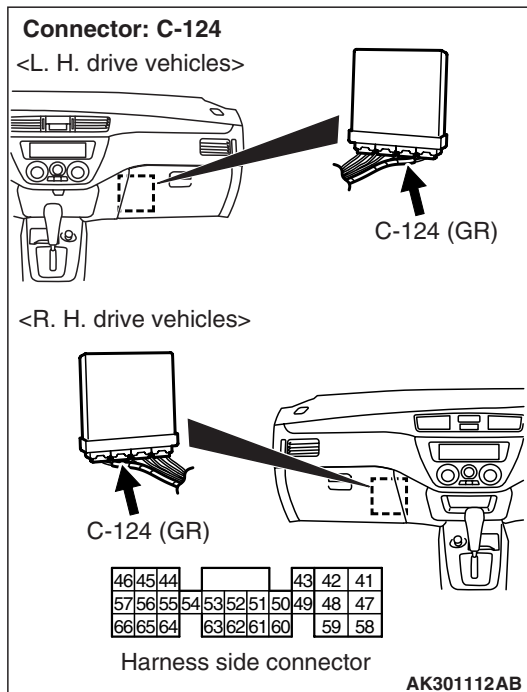
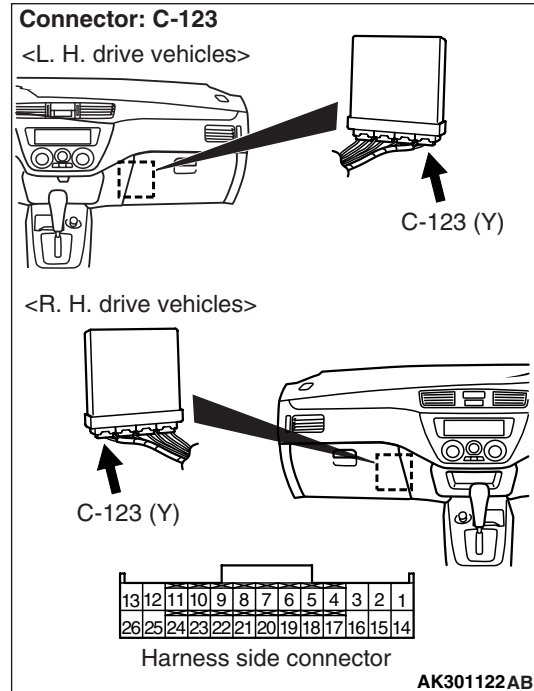
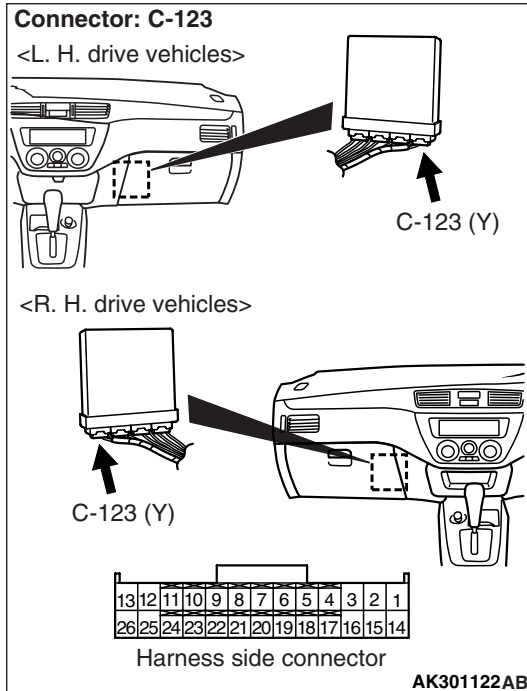

Q: Is the check result normal?

YES : Go to Step 11 .

NO : Repair or replace.

- Disconnect connector, and measure at harness side.
- Resistance between terminal No. 13 <M/T> or No. 48 <A/T> and earth, and No. 26 <M/T> or No. 42 <A/T> and earth.

OK: Continuity (2 Ω or less)

Q: Is the check result normal?

YES : Go to Step 12 .

NO : Check and repair harness between C-123 (terminal No. 13, No. 26) engine-ECU <M/T> connector or C-124 (terminal No. 42, No. 48) engine-A/T-ECU <A/T> connector and body earth.

- Check earthing line for open circuit and damage.

STEP 12. Connector check: C-125 engine-ECU <M/T> connector or C-124 engine-A/T-ECU <A/T> connector

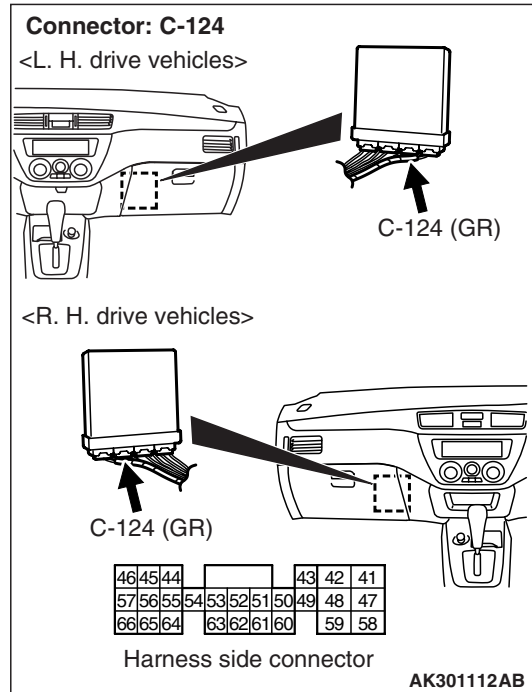
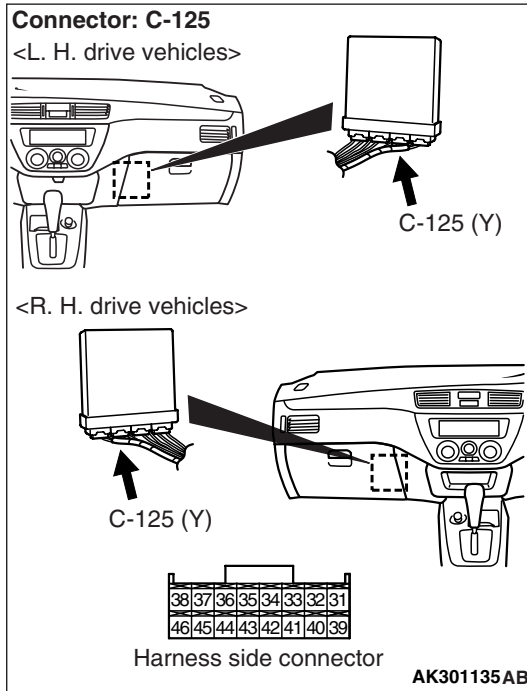

Q: Is the check result normal?

YES : Go to Step 13 .

NO : Repair or replace.

STEP 13. Perform voltage measurement at C-125 engine-ECU <M/T> connector or C-124 engine-A/T-ECU <A/T> connector.

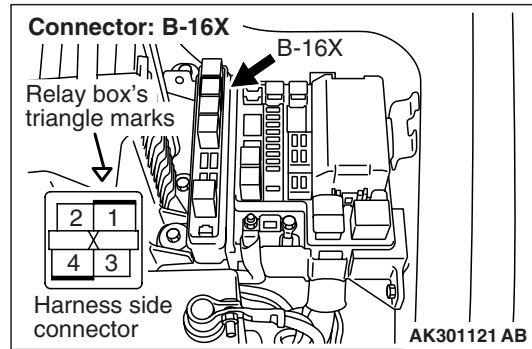
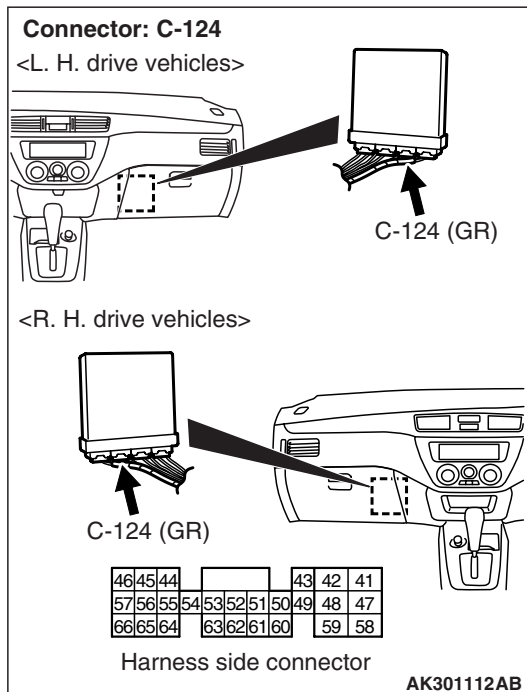
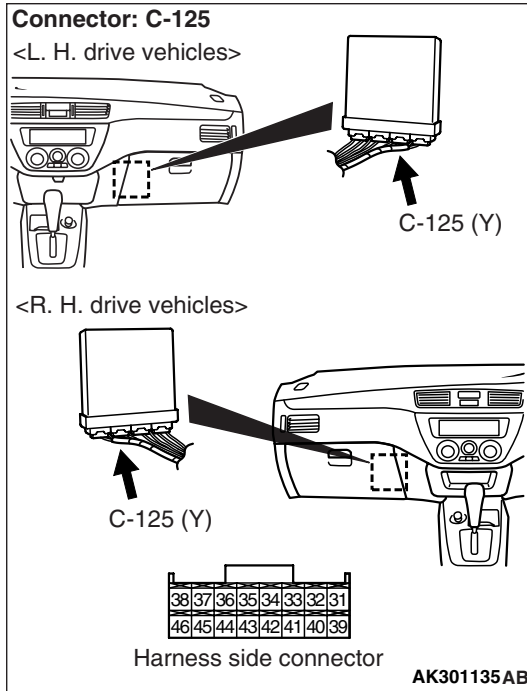

- Disconnect connector, and measure at harness side.
- Voltage between terminal No. 38 <M/T> or terminal No. 49 <A/T> and earth.

OK: System voltage

Q: Is the check result normal?

YES : Go to Step 14 .

NO : Check and repair harness between B-16X (terminal No. 3) engine control relay connector and C-125 (terminal No. 38) engine-ECU <M/T> connector or C-124 (terminal No. 49) engine-A/T-ECU <A/T> connector.

- Check earthing line for open/short circuit.

STEP 14. Perform voltage measurement at C-123 engine-ECU <M/T> connector or C-124 engine-A/T-ECU <A/T> connector.

Q: Is the check result normal?

YES : Go to Step 15 .

NO : Check intermediate connector C-12*¹,

C-134*² and repair if necessary. If intermediate connector is normal, check and repair harness between C-123 (terminal No. 12, No. 25) engine-ECU <M/T> connector or C-124 (terminal No. 41, No. 47) engine-A/T-ECU <A/T> connector and B-16X (terminal No. 4) engine-control relay.

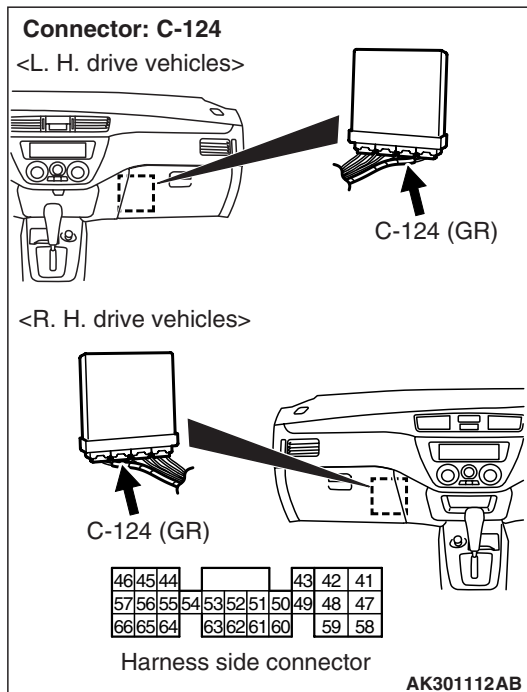
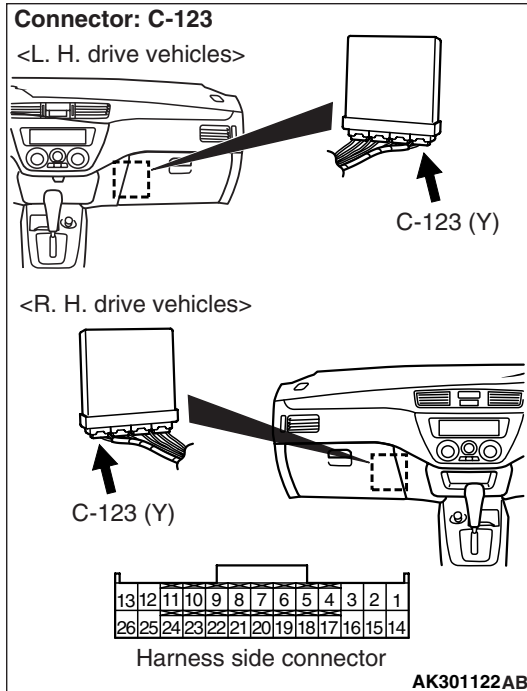

- Disconnect connector, and measure at harness side.
- Using jumper wire, connect C-125 (terminal No. 38) engine-ECU <M/T> connector or C-124 (terminal No. 49) engine-A/T-ECU <A/T> and earth.
- Voltage between terminal No. 12 <M/T> or terminal No. 41 <A/T> and earth, and terminal No. 25 <M/T> or terminal No. 47 <A/T> and earth.

OK: System voltage

STEP 15. Check harness between C-201 (terminal No. 2) ignition switch connector and C-129 (terminal No. 82) engine-ECU <M/T> connector or C-126 (terminal No. 98) engine-A/T-ECU <A/T> connector.

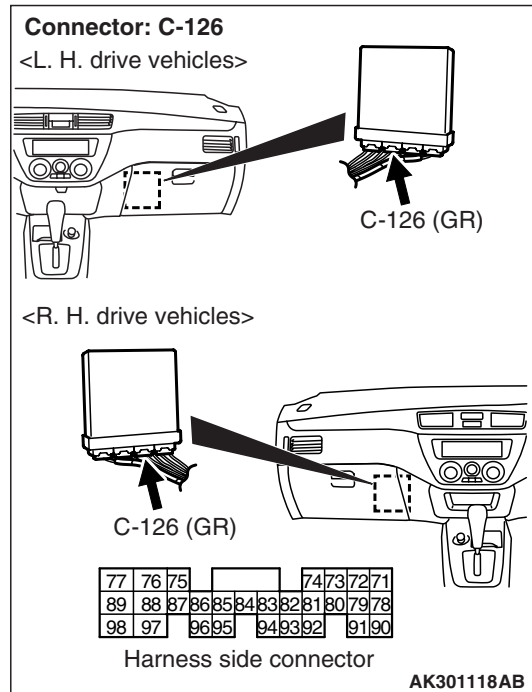
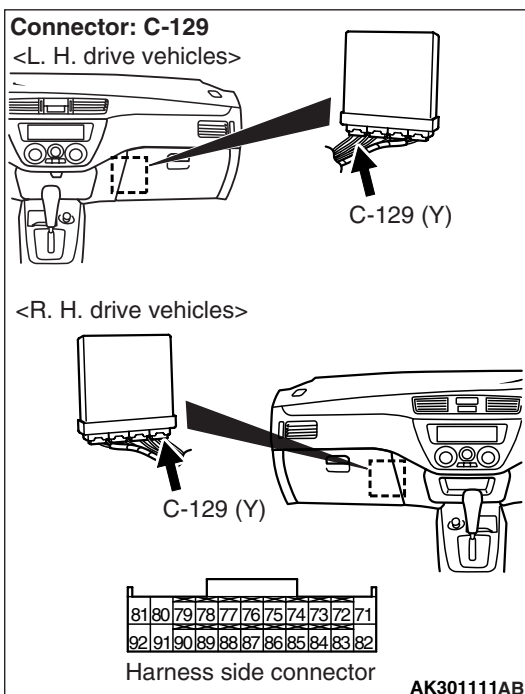

NOTE: Before checking harness, check intermediate connectors C-14*¹, C-136*², C-212 and C-210 and repair if necessary.

- Check output line for open/short circuit.

Q: Is the check result normal?

- YES :** Go to Step 16 .
NO : Repair.

STEP 16. Check harness between B-16X (terminal No. 1, No. 2) engine control relay connector and battery.

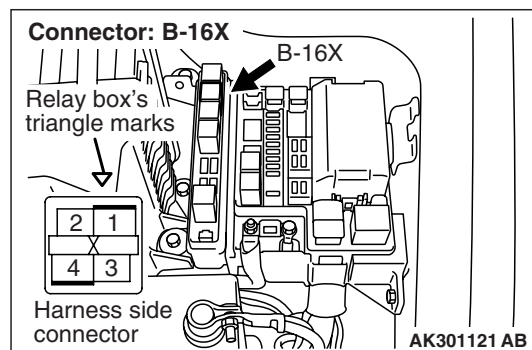

NOTE: Before checking harness, check intermediate connector A-13*², C-111*², and repair if necessary.

- Check power supply line for damage.

Q: Is the check result normal?

- YES :** Go to Step 17 .
NO : Repair.

STEP 17. Check harness between B-16X (terminal No. 3) engine control relay connector and C-125 (terminal No. 38) engine-ECU <M/T> connector or C-124 (terminal No. 49) engine-A/T-ECU <A/T> connector.

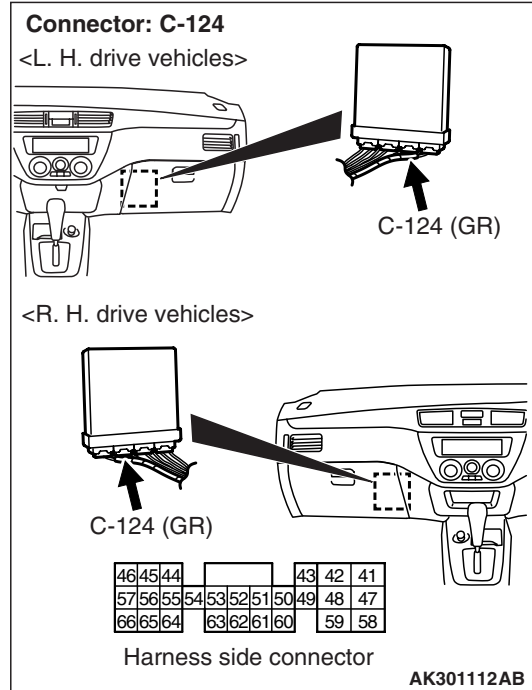
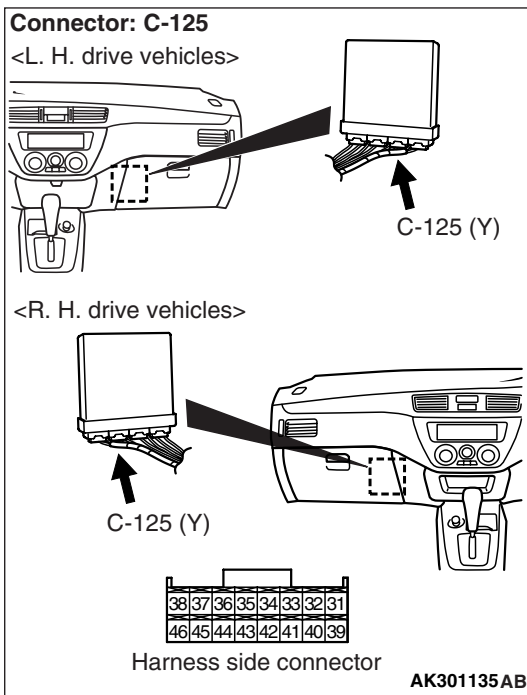
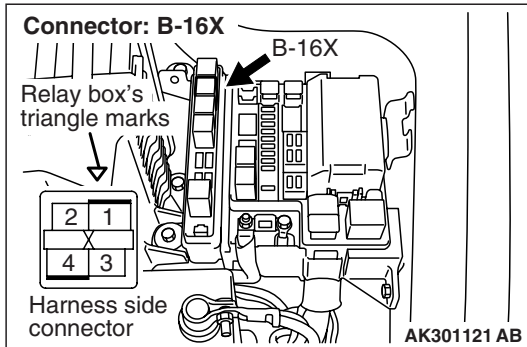

- Check earthing line for damage.

Q: Is the check result normal?

YES : Go to Step 18 .

NO : Repair.

STEP 18. Check harness between B-16X (terminal No. 4) engine control relay connector and C-123 (terminal No. 12, No. 25) engine-ECU <M/T> connector or C-124 (terminal No. 41, No. 47) engine-A/T-ECU <A/T> connector.

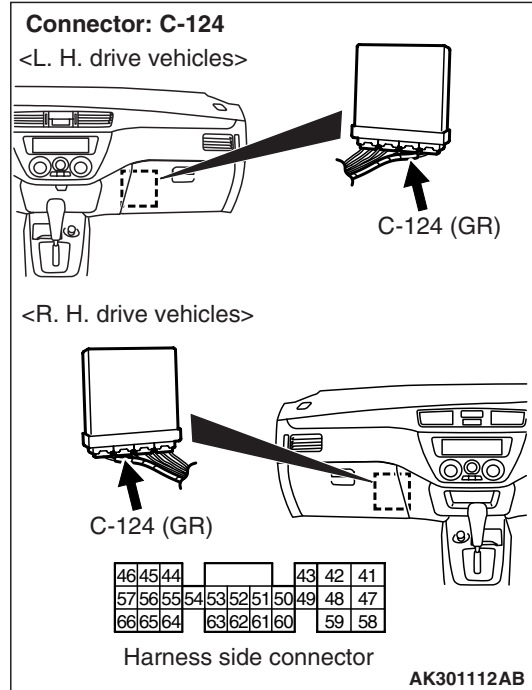
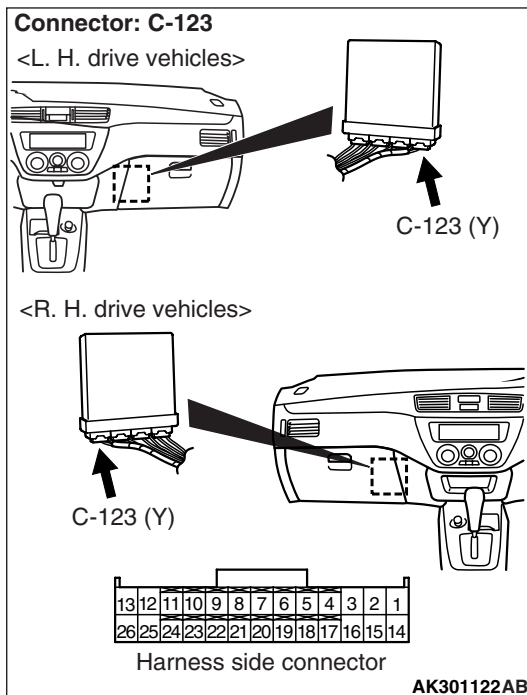
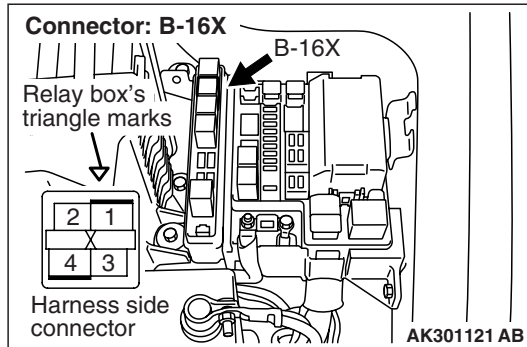

NOTE: Before checking harness, check intermediate connector C-12*¹, C-134*², and repair if necessary.

- Check output line for damage.

Q: Is the check result normal?

YES : Go to Step 19 .

NO : Repair.

STEP 19. Check the trouble symptoms.

Q: Does trouble symptom persist?

YES : Replace engine-ECU <M/T> or engine-A/T-ECU <A/T>.

NO : Intermittent malfunction (Refer to GROUP 00 –How to Use Troubleshooting/Inspection Service Points P.00-5).

Inspection Procedure 24: Fuel Pump System

Fuel pump circuit

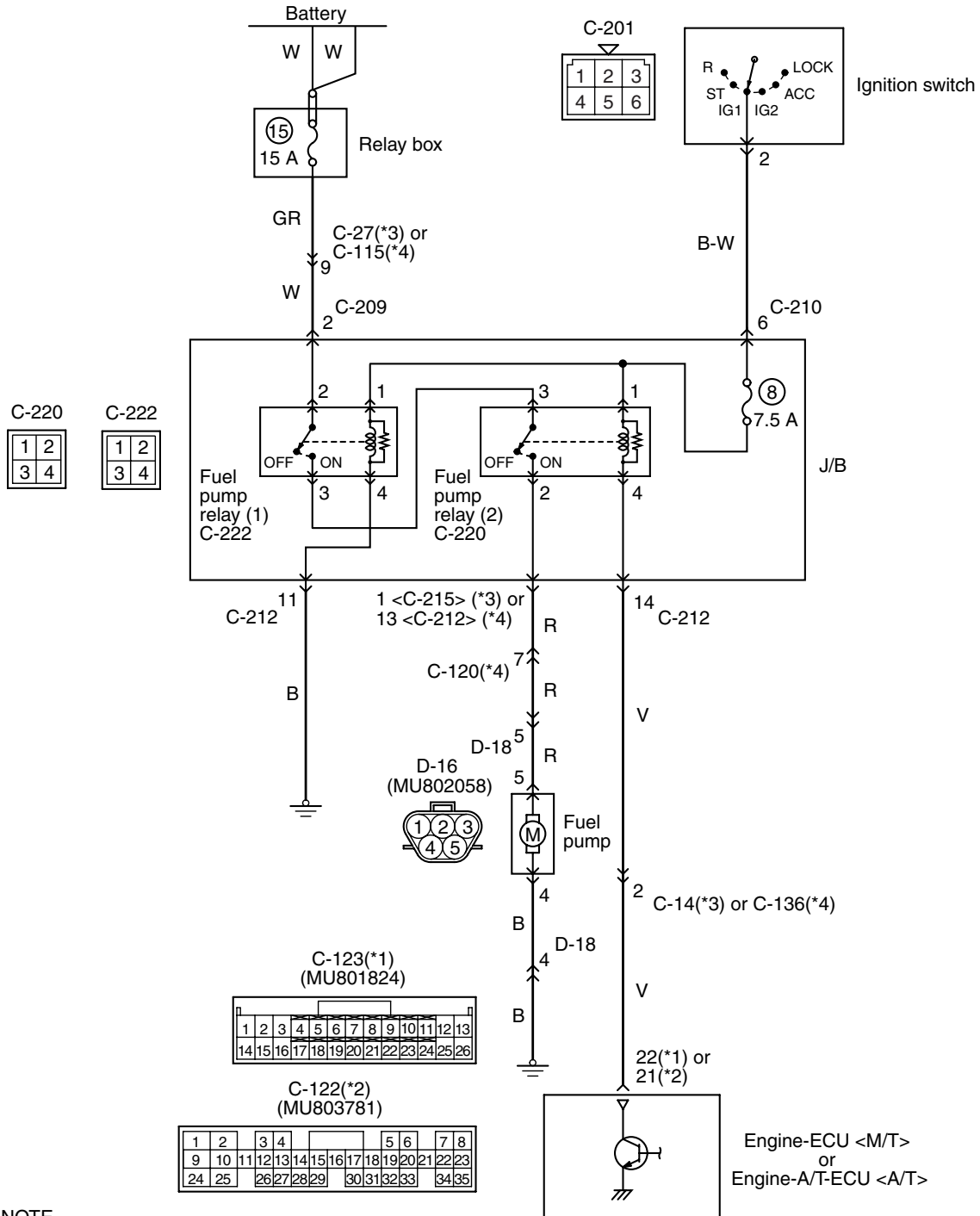

NOTE
 *1: M/T
 *2: A/T
 *3: L.H. drive vehicles
 *4: R.H. drive vehicles

Wire colour code
 B: Black LG: Light green G: Green L: Blue W: White Y: Yellow SB: Sky blue BR: Brown O: Orange GR: Gray
 R: Red P: Pink V: Violet

OPERATION

- The battery voltage is applied to the fuel pump relay (1) (terminal No. 1) from the ignition switch and is earthed to the vehicle body from the fuel pump relay (1) (terminal No. 4).
- The battery voltage is applied to the fuel pump relay (1) (terminal No. 2) and to the fuel pump relay (2) (terminal No. 3) from the fuel pump relay (1) (terminal No. 3).
- The battery voltage is applied to the fuel pump relay (2) (terminal No. 1) from the ignition switch. The engine-ECU (terminal No. 22) <M/T> or engine-A/T-ECU (terminal No. 21) <A/T> makes the power transistor in the unit be in "ON" position and makes currents go on the fuel pump relay (2) coil, and that makes the relay be in "ON" position.
- When the fuel pump relay (2) is in "ON" position, the battery voltage is supplied to the fuel pump from the fuel pump relay (2) (terminal No. 2).

FUNCTION

- When the ignition switch ON signal is input to the engine-ECU <M/T> or engine-A/T-ECU <A/T>, the engine-ECU <M/T> or engine-A/T-ECU <A/T> places the fuel pump relay in the "ON" position. Accordingly, the battery voltage is supplied to the fuel pump.

PROBABLE CAUSE

- Failed fuel pump relay
- Failed fuel pump
- Open/short circuit in fuel pump drive circuit or loose connector contact
- Failed engine-ECU <M/T>
- Failed engine-A/T-ECU <A/T>

DIAGNOSIS PROCEDURE

NOTE:

- *1: L.H. drive vehicles
- *2: R.H. drive vehicles

STEP 1. Connector check: C-222 fuel pump relay (1) connector and C-220 fuel pump relay (2) connector

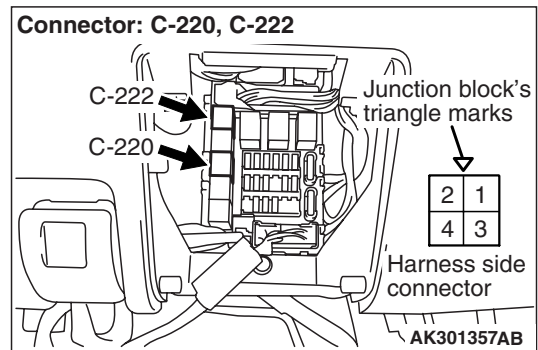

Q: Is the check result normal?

- YES : Go to Step 2 .
- NO : Repair or replace.

STEP 2. Check fuel pump relay.

- Fuel pump relay, continuity check (Refer to P.13A-404).

Q: Is the check result normal?

- YES : Go to Step 3 .
- NO : Replace fuel pump relay.

STEP 3. Perform resistance measurement at C-222 fuel pump relay (1) connector.

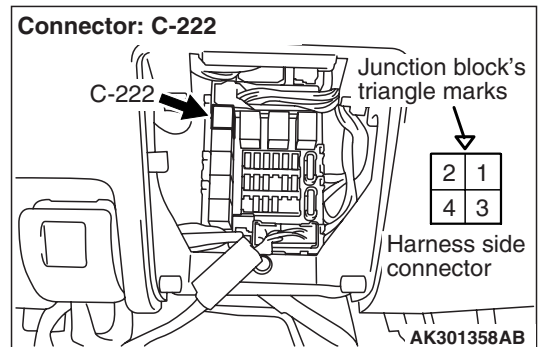

- Remove relay, and measure at junction block side.
- Resistance between terminal No. 4 and earth.
OK: Continuity (2 Ω or less)

Q: Is the check result normal?

- YES : Go to Step 4 .
- NO : Check intermediate connector C-212, and repair if necessary. If intermediate connector is normal, check and repair harness between C-222 (terminal No. 4) fuel pump relay (1) connector and body earth.
 - Check earthing line for open circuit and damage.

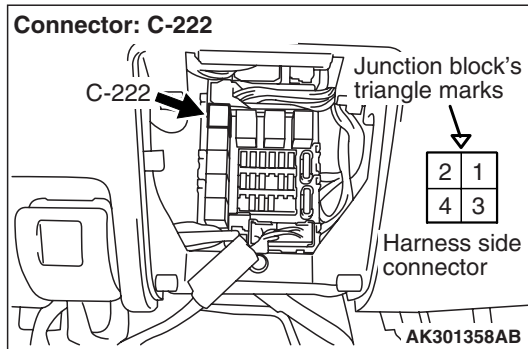
STEP 4. Perform voltage measurement at C-222 fuel pump relay (1) connector.

- Remove relay, and measure at junction block side.
- Ignition switch: ON
- Voltage between terminal No. 1 and earth.

OK: System voltage

Q: Is the check result normal?

YES : Go to Step 6 .

NO : Go to Step 5 .

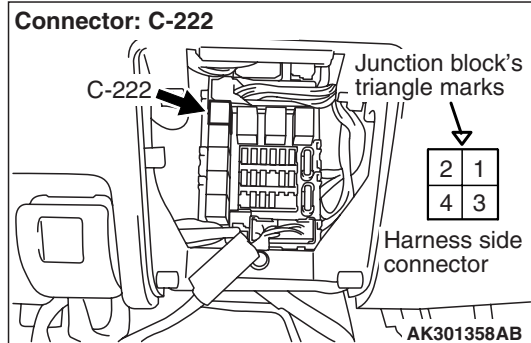
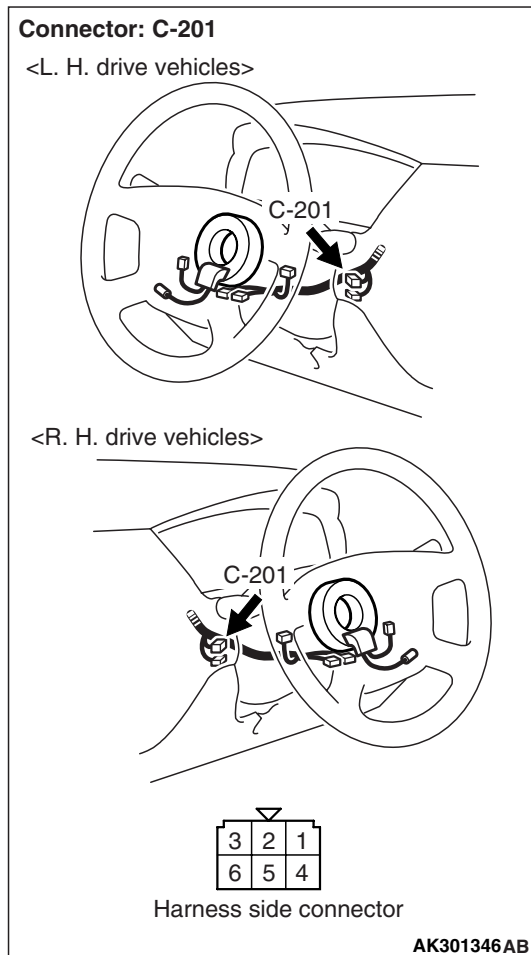
STEP 5. Connector check: C-201 ignition switch connector

Q: Is the check result normal?

YES : Check intermediate connector C-210, and repair if necessary. If intermediate connector is normal, check and repair harness between C-222 (terminal No. 1) fuel pump relay (1) connector and C-201 (terminal No. 2) ignition switch connector.

- Check power supply line for open circuit and damage.

NO : Repair or replace.

STEP 6. Perform voltage measurement at C-222 fuel pump relay (1) connector.

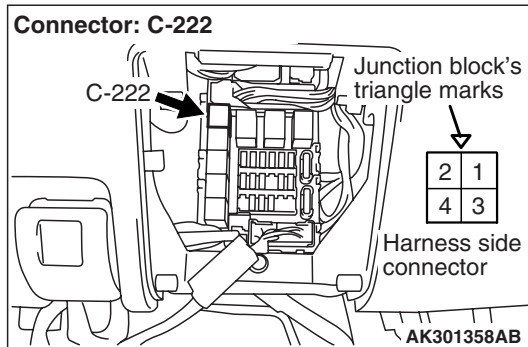

- Remove relay, and measure at junction block side.
- Voltage between terminal No. 2 and earth.

OK: System voltage

Q: Is the check result normal?

YES : Go to Step 7 .

NO : Check intermediate connectors C-27*¹, C-115*², and repair if necessary. If intermediate connectors are normal, check and repair harness between C-222 (terminal No. 2) fuel pump relay (1) connector and battery.

- Check power supply line for open/short circuit.

STEP 7. Perform voltage measurement at C-220 fuel pump relay (2) connector.

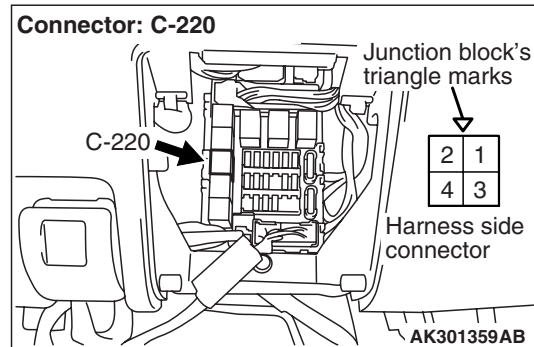

Connector: C-201

<L. H. drive vehicles>

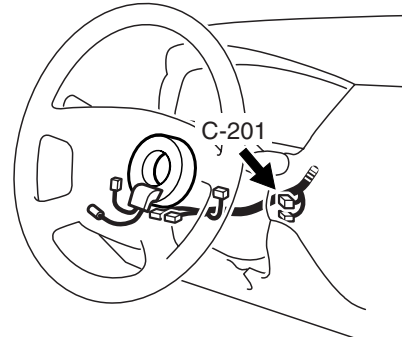

<R. H. drive vehicles>

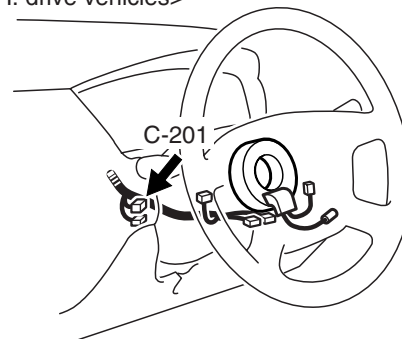

3	2	1
6	5	4

Harness side connector

AK301346AB

- Remove relay, and measure at junction block side.
- Ignition switch: ON
- Voltage between terminal No. 1 and earth.

OK: System voltage

Q: Is the check result normal?

YES : Go to Step 8 .

NO : Check intermediate connector C-210, and repair if necessary. If intermediate connector is normal, check and repair harness between C-201 (terminal No. 2) ignition switch connector and C-220 (terminal No. 1) fuel pump relay (2) connector.

- Check power supply line for open/short circuit.

STEP 8. Connector check: C-123 engine-ECU <M/T> connector or C-122 engine-A/T-ECU <A/T> connector

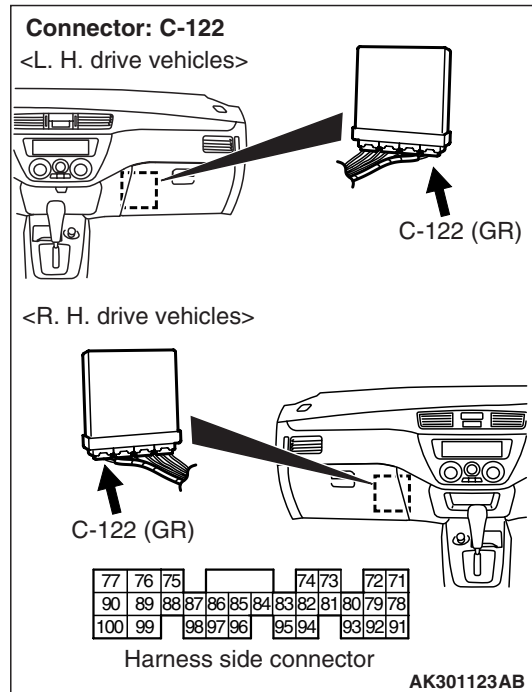
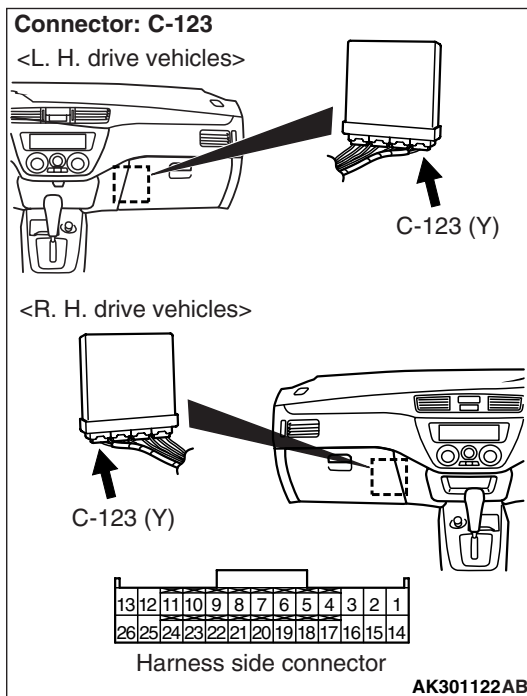

Q: Is the check result normal?

YES : Go to Step 9 .

NO : Repair or replace.

STEP 9. Perform voltage measurement at C-123 engine-ECU <M/T> connector or C-122 engine-A/T-ECU <A/T> connector.

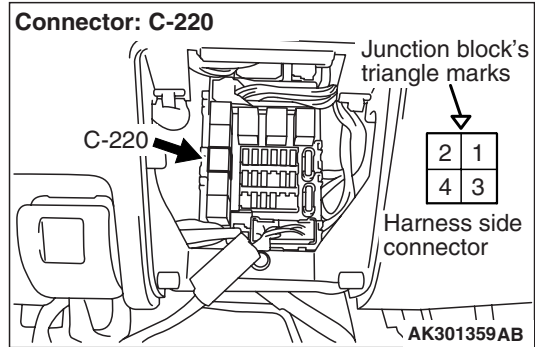
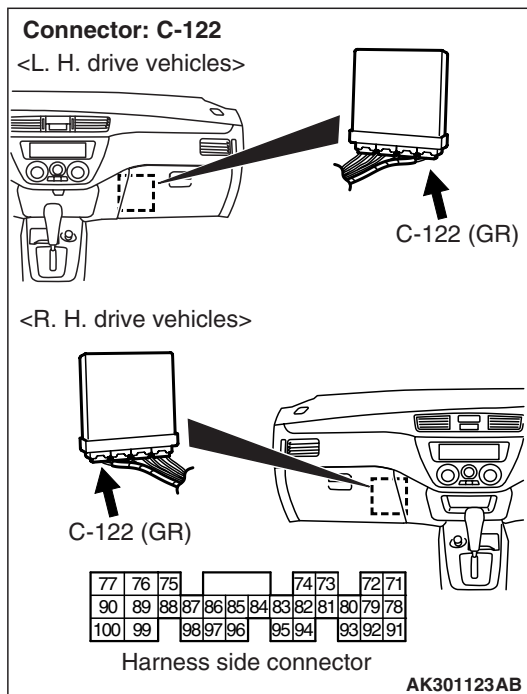
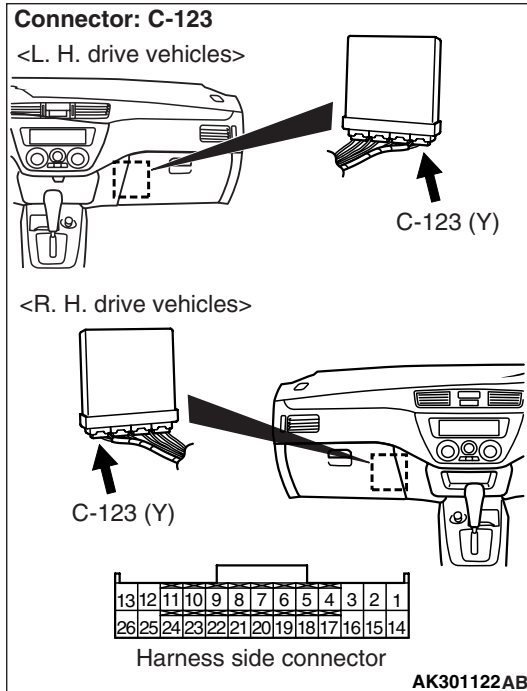

- Disconnect connector, and measure at harness side.
- Ignition switch: ON
- Voltage between terminal No. 22 <M/T> or terminal No. 21 <A/T> and earth.

OK: System voltage

Q: Is the check result normal?

YES : Go to Step 10 .

- NO :** Check intermediate connectors C-14^{*1}, C-136^{*2} and C-212, and repair if necessary. If intermediate connectors are normal, check and repair harness between C-220 (terminal No. 4) fuel pump relay (2) connector and C-123 (terminal No. 22) engine-ECU <M/T> or C-122 (terminal No. 21) engine-A/T-ECU <A/T> connector.
- Check earthing line for open/short circuit.

STEP 10. Connector check: D-16 fuel pump connector

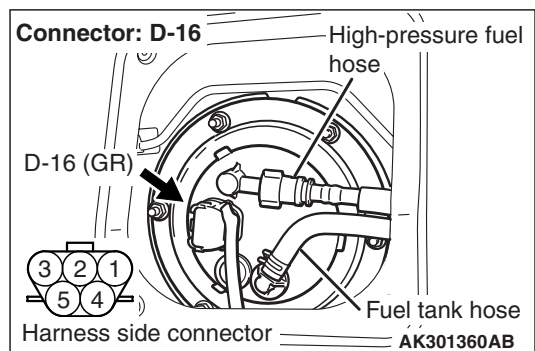

Q: Is the check result normal?

YES : Go to Step 11 .

NO : Repair or replace.

STEP 11. Perform voltage measurement at D-16 fuel pump connector.

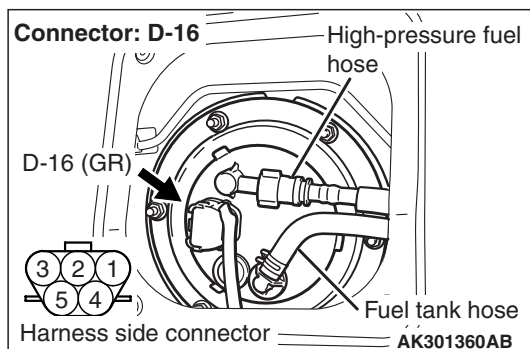

- Disconnect connector, and measure at harness side.
- Ignition switch: ON
- Using a jumper wire, connect C-123 (terminal No. 22) engine-ECU <M/T> connector or C-122 (terminal No. 21) engine-A/T-ECU <A/T> connector and earth.
- Voltage between terminal No. 5 and earth.

OK: System voltage

Q: Is the check result normal?

YES : Go to Step 14 .

NO : Go to Step 12 .

STEP 12. Check harness between C-220 (terminal No. 2) fuel pump relay (2) connector and D-16 (terminal No. 5) fuel pump connector.

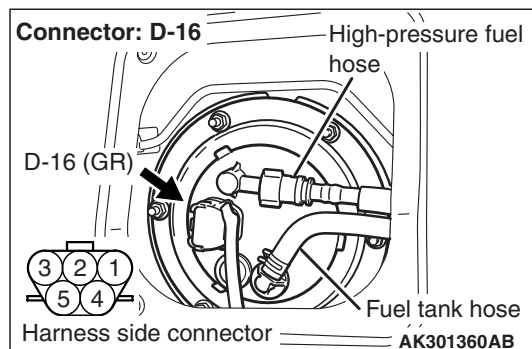
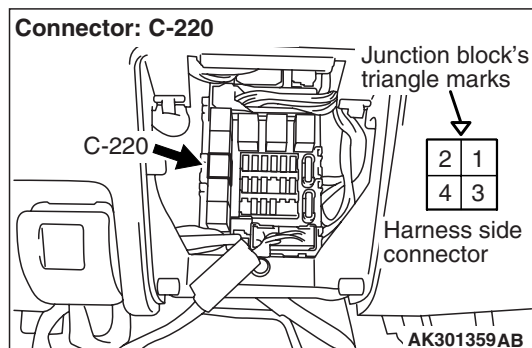

NOTE: Before checking harness, check intermediate connectors C-215*¹, C-212*² and C-120*² and D-18, and repair if necessary.

- Check output line for open/short circuit and damage.

Q: Is the check result normal?

YES : Go to Step 13 .

NO : Repair.

STEP 13. Check harness between C-222 (terminal No. 3) fuel pump relay (1) connector and C-220 (terminal No. 3) fuel pump relay (2) connector.

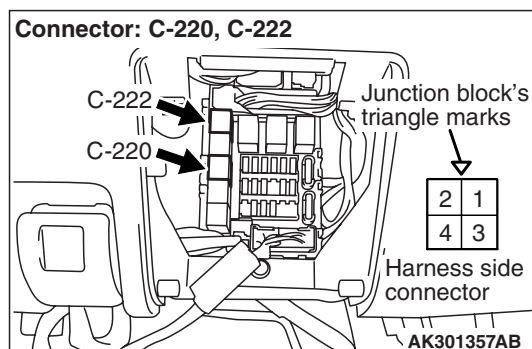

- Check power supply line for open/short circuit.

Q: Is the check result normal?

YES : Go to Step 14 .

NO : Repair.

STEP 14. Check harness between C-201 (terminal No. 2) ignition switch connector and C-222 (terminal No. 1) fuel pump relay (1) connector.

STEP 15. Check harness between C-201 (terminal No. 2) ignition switch connector and C-220 (terminal No. 1) fuel pump relay (2) connector.

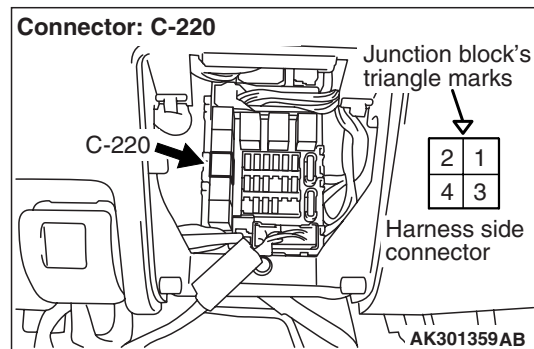
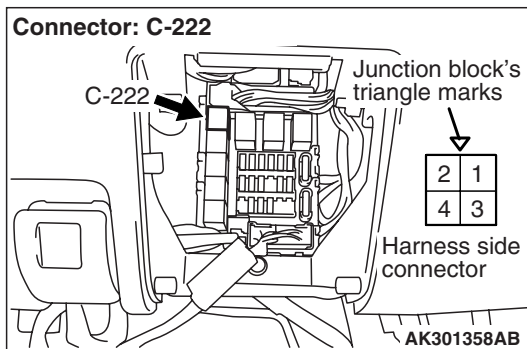
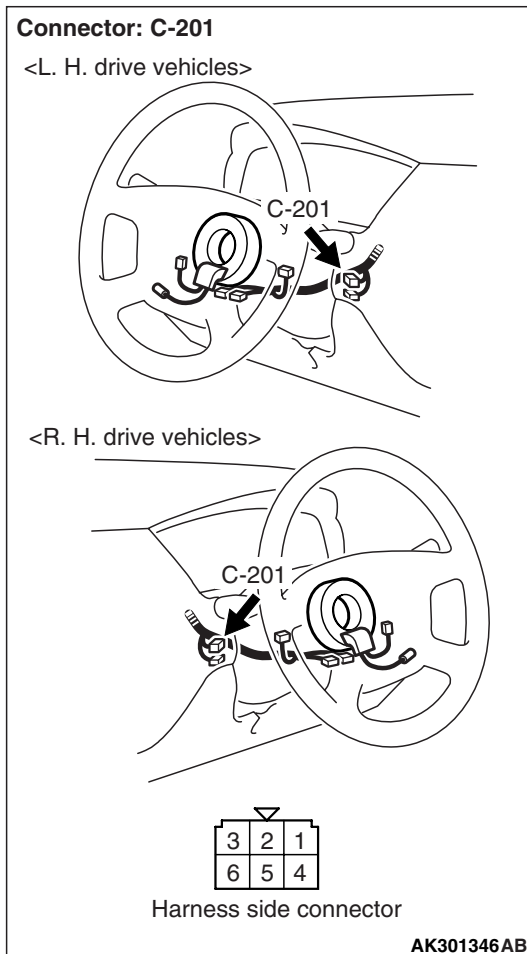

NOTE: Before checking harness, check intermediate connector C-210, and repair if necessary.

- Check power supply line for damage.

Q: Is the check result normal?

YES : Go to Step 15 .

NO : Repair.

- Check power supply line for damage.

Q: Is the check result normal?

YES : Go to Step 16 .

NO : Repair.

STEP 16. Check harness between C-220 (terminal No.4) fuel pump relay (2) connector and C-123 (terminal No.22) engine-ECU <M/T> connector or C-122 (terminal No.21) engine-A/T-ECU <A/T> connector.

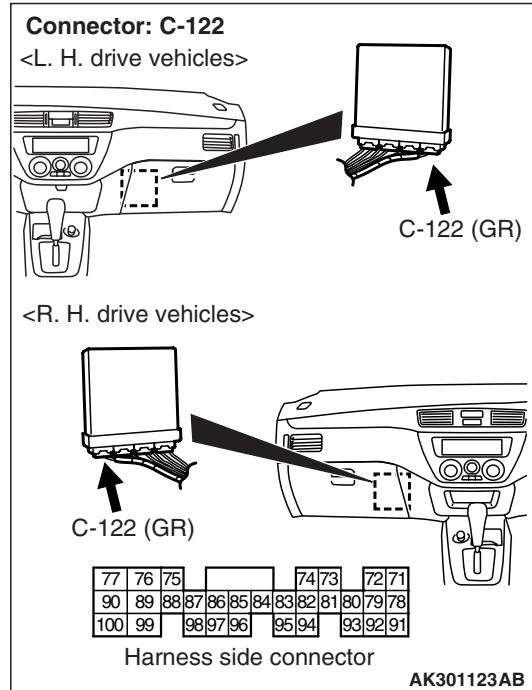
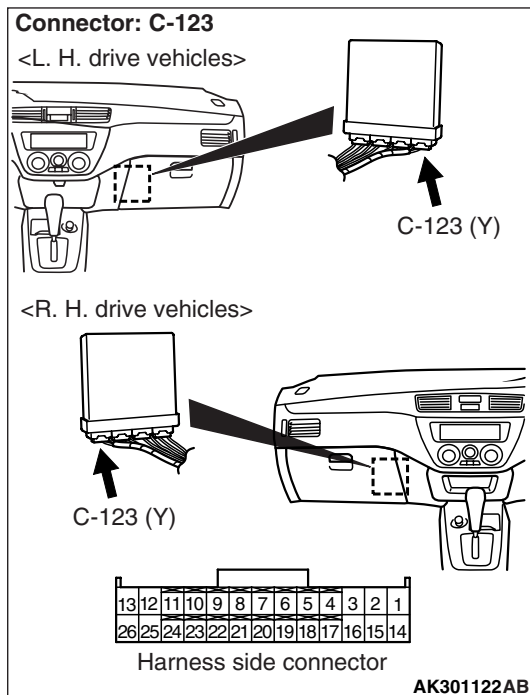
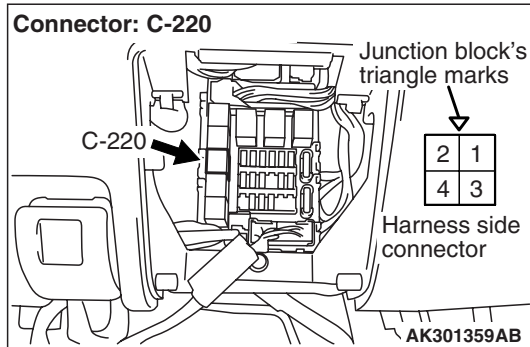

NOTE: Before checking harness, check intermediate connectors C-14*¹, C-136*² and C-212, and repair if necessary.

- Check earthing line for damage.

Q: Is the check result normal?

- YES :** Go to Step 22 .
- NO :** Repair.

STEP 17. Perform resistance measurement at D-16 fuel pump connector.

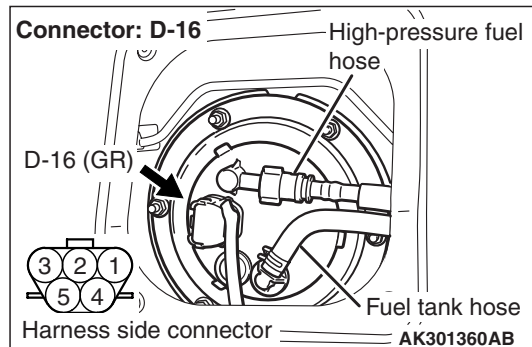

- Disconnect connector, and measure at harness side.
- Resistance between terminal No.4 and earth.

OK: Continuity (2 Ω or less)

Q: Is the check result normal?

YES : Go to Step 18 .

NO : Check intermediate connector D-18, and repair if necessary. If intermediate connector D-16 (terminal No.4) fuel pump connector and body earth.

- Check earthing line for open circuit and damage.

STEP 18. Check harness between battery and C-222 (terminal No.2) fuel pump relay (1) connector.

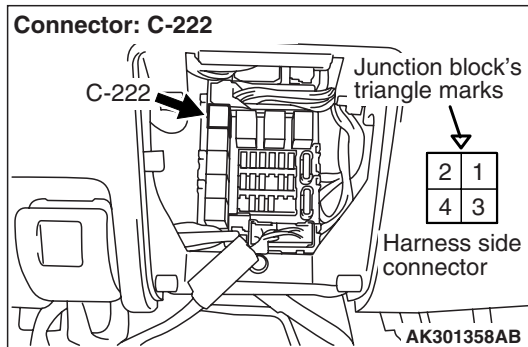

NOTE: Before checking harness, check intermediate connectors C-27*¹, C-115*² and C-209, and repair if necessary.

- Check power supply line for damage.

Q: Is the check result normal?

YES : Go to Step 19 .

NO : Repair.

STEP 19. Check harness between C-222 (terminal No.3) fuel pump relay (1) connector and C-220 (terminal No.3) fuel pump relay (2) connector.

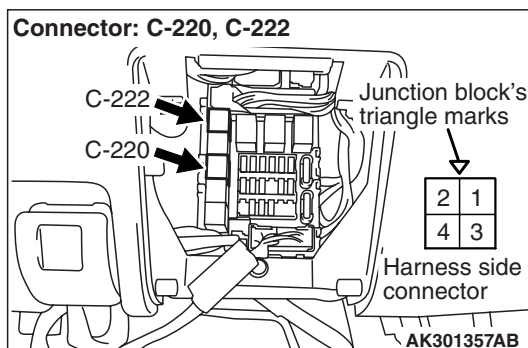

- Check power supply line for damage.

Q: Is the check result normal?

YES : Go to Step 20 .

NO : Repair.

STEP 20. Check harness between C-220 (terminal No.2) fuel pump relay (2) connector and D-16 (terminal No.5) fuel pump connector.

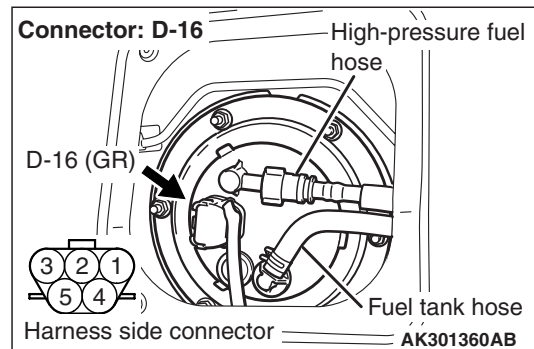
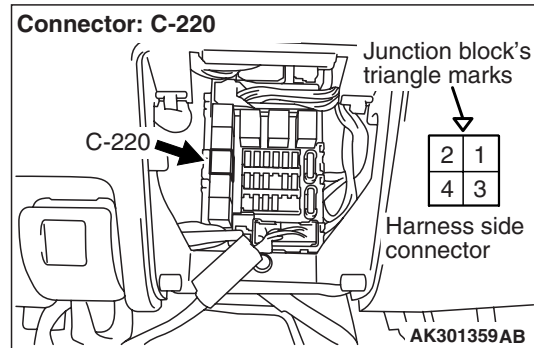

NOTE: Before checking harness, check intermediate connectors C-215*¹, C-212*² and C-120*² and D-18, and repair if necessary.

- Check output line for damage.

Q: Is the check result normal?

YES : Go to Stop 21 .

NO : Repair.

STEP 21. Check fuel pump itself.

- Check fuel pump itself (Refer to P.13A-401).

Q: Is the check result normal?

YES : Go to Stop 22 .

NO : Replace fuel pump.

STEP 22. M.U.T.-II/III actuator test

- Refer to actuator test reference table P.13A-383.

Q: Is the check result normal?

YES : Intermittent malfunction (Refer to GROUP 00 –How to Use Troubleshooting/Inspection Service Points P.00-5).

NO : Replace engine-ECU<M/T> or engine-A/T-ECU<A/T>.

Inspection Procedure 25: Fan Control Relay System

Fan control relay circuit

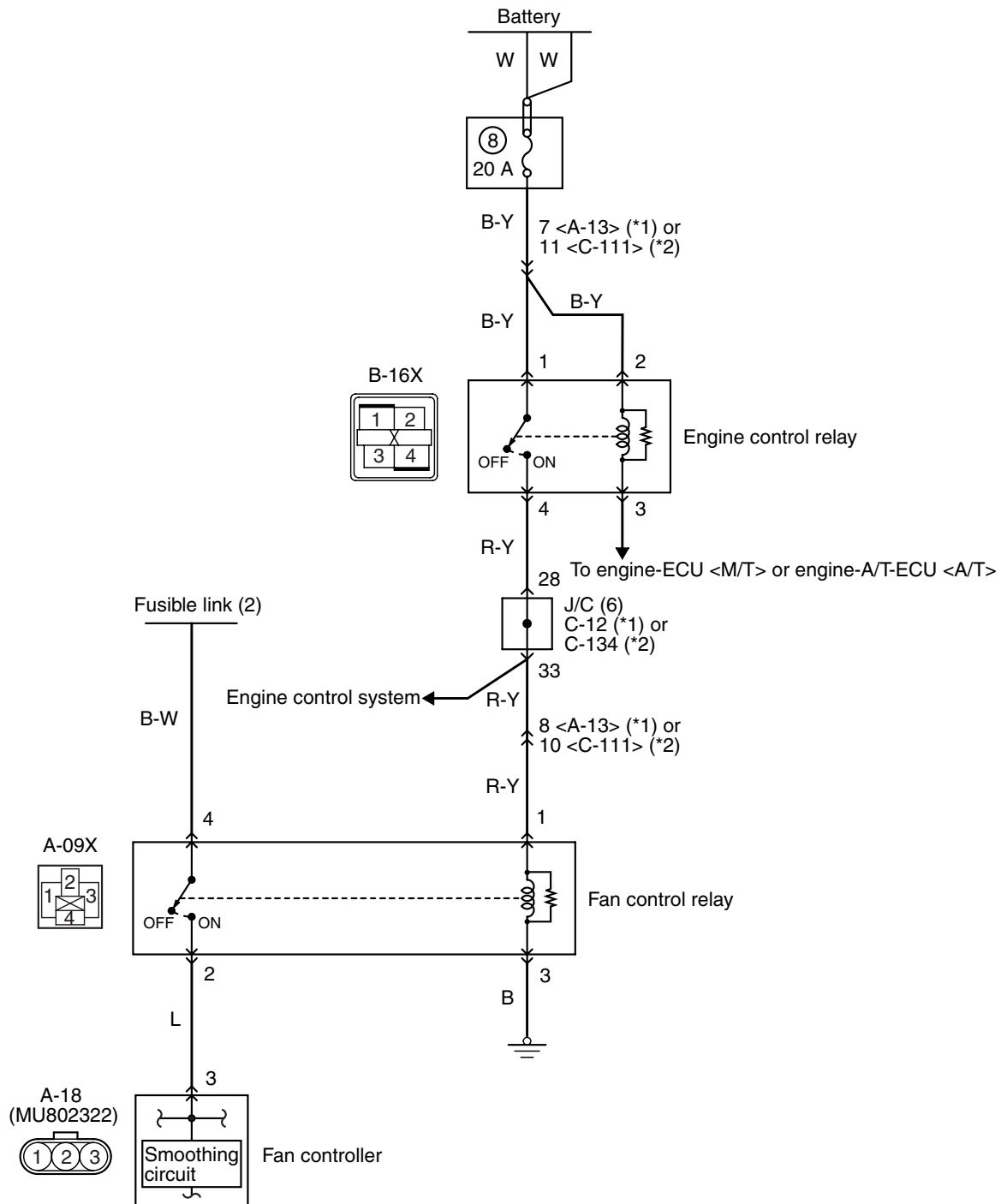

NOTE

- *1: L.H. drive vehicles
- *2: R.H. drive vehicles

Wire colour code

B: Black LG: Light green G: Green L: Blue W: White Y: Yellow SB: Sky blue BR: Brown O: Orange GR: Gray
R: Red P: Pink V: Violet

OPERATION

- The battery voltage is applied to the fan control relay (terminal No. 1) from the engine control relay (terminal No. 4) and is earthed to the vehicle body from the fan control relay (terminal No. 3).
- The battery voltage is applied to the fan control relay (terminal No. 4).
- When the fan control relay is in "ON" position, the battery voltage is supplied to the fan controller (terminal No. 3) from the fan control relay (terminal No. 2).

FUNCTION

- When the engine control relay is in "ON" position, the fan control relay is also simultaneously placed in "ON" position. Accordingly, the battery voltage is supplied to the fan controller.

PROBABLE CAUSE

- Failed fan control relay
- Failed fan controller
- Failed radiator fan motor
- Failed condenser fan motor
- Open/short circuit in fan control relay circuit or loose connector contact
- Failed engine-ECU <M/T>
- Failed engine-A/T-ECU <A/T>

DIAGNOSIS PROCEDURE

NOTE:

- *1: L.H. drive vehicles
- *2: R.H. drive vehicles

STEP 1. Connector check: A-09X fan control relay connector

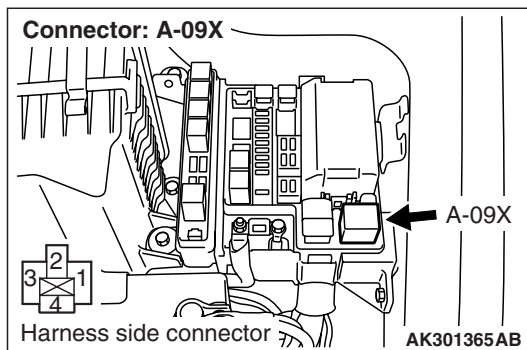

Q: Is the check result normal?

- YES : Go to Step 2 .
- NO : Repair or replace.

STEP 2. Check fan control relay.

- Check fan control relay (Refer to GROUP 14 – On-vehicle Service P.14-24).

Q: Is the check result normal?

- YES : Go to Step 3 .
- NO : Replace fan control relay.

STEP 3. Perform resistance measurement at A-09X fan control relay connector.

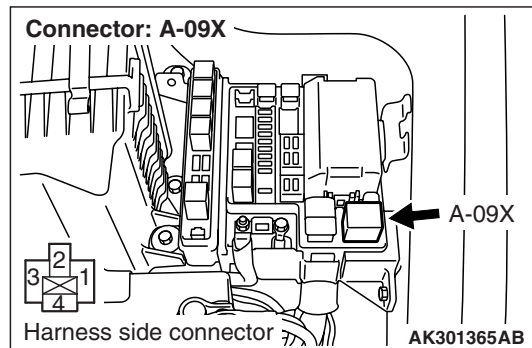

- Remove relay and measure at relay box side.
- Resistance between terminal No. 3 and earth.

OK: Continuity (2 Ω or less)

Q: Is the check result normal?

- YES : Go to Step 4 .
- NO : Check and repair harness between A-09X (terminal No. 3) fan control relay connector and body earth.
 - Check earthing line for open circuit and damage.

STEP 4. Perform voltage measurement at A-09X fan control relay connector.

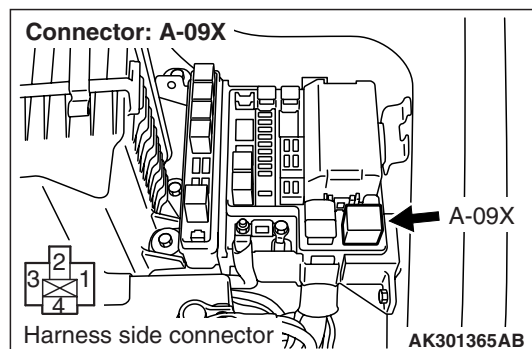

- Remove relay and measure at relay box side.
- Ignition switch: ON
- Voltage between terminal No. 1 and earth.

OK: System voltage

Q: Is the check result normal?

- YES : Go to Step 6 .
- NO : Go to Step 5 .

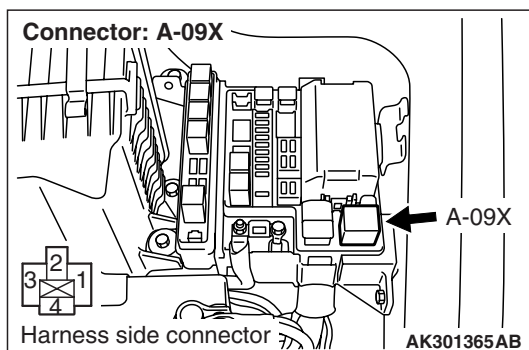
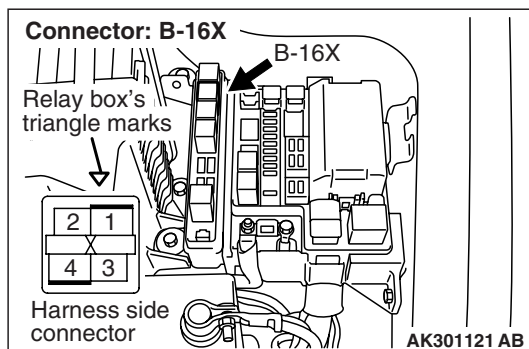
STEP 5. Connector check: B-16X engine control relay connector**Q: Is the check result normal?**

YES : Check intermediate connectors A-13*¹, C-111*² and C-12*¹, C-134*², and repair if necessary. If intermediate connectors are normal, check and repair harness between B-16X (terminal No. 4) engine control relay connector and A-09X (terminal No. 1) fan control relay connector.

- Check power supply line for open/short circuit.

NO : Repair or replace.

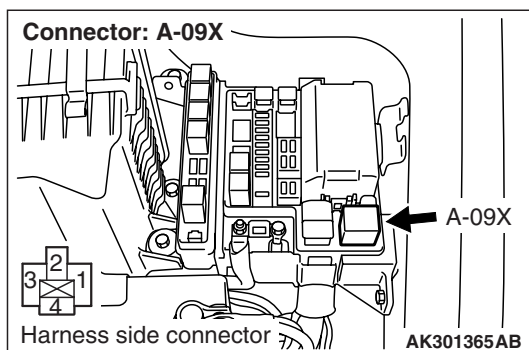
STEP 6. Perform voltage measurement at A-09X fan control relay connector.

- Remove relay, and measure at relay box side.
- Voltage between terminal No. 4 and earth

OK: System voltage

Q: Is the check result normal?

YES : Go to Step 7 .

NO : Check and repair harness between battery and A-09X (terminal No. 4) fan control relay connector.

- Check power supply line for open/short circuit.

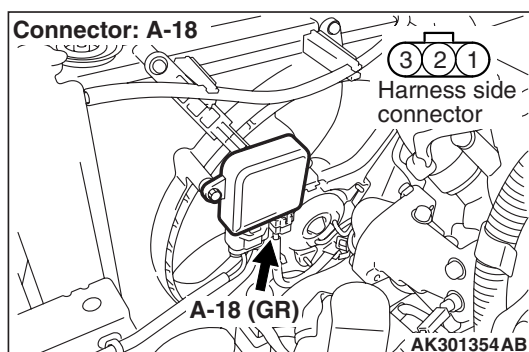
STEP 7. Connector check: A-18 fan controller connector**Q: Is the check result normal?**

YES : Go to Step 8 .

NO : Repair or replace.

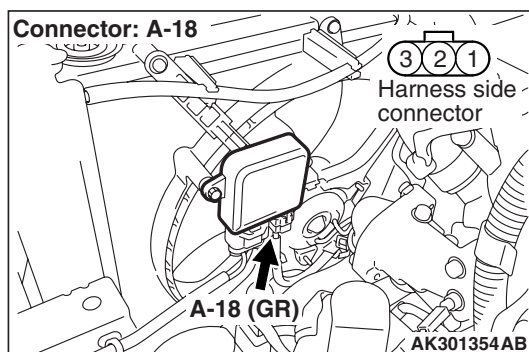
STEP 8. Perform voltage measurement at A-18 fan controller connector.

- Disconnect connector, and measure at harness side.
- Ignition switch: ON
- Voltage between terminal No. 3 and earth.

OK: System voltage

Q: Is the check result normal?

YES : Go to Step 12 .

NO : Go to Step 9 .

STEP 9. Check harness between A-09X (terminal No. 2) fan control relay connector and A-18 (terminal No. 3) fan controller connector.

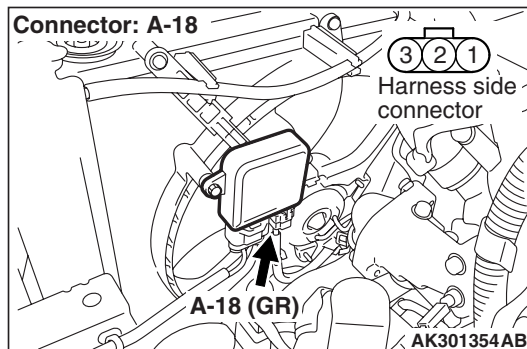
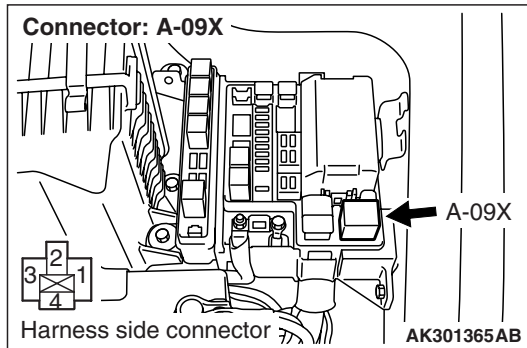

- Check output line for open/short circuit.

Q: Is the check result normal?

- YES :** Go to Step 10 .
NO : Repair.

STEP 10. Connector check: B-16X engine control relay connector

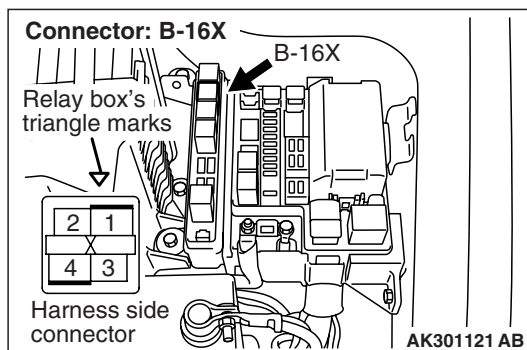

Q: Is the check result normal?

- YES :** Go to Step 11 .
NO : Repair or replace.

STEP 11. Check harness between B-16X (terminal No. 4) engine control relay connector and A-09X (terminal No. 1) fan control relay connector.

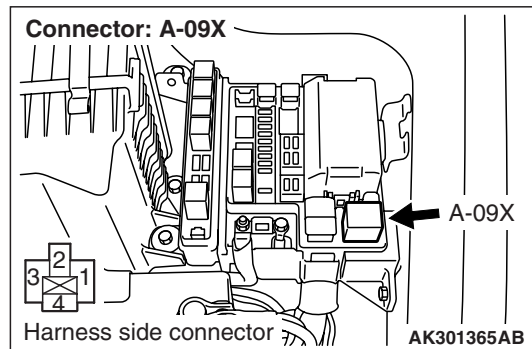
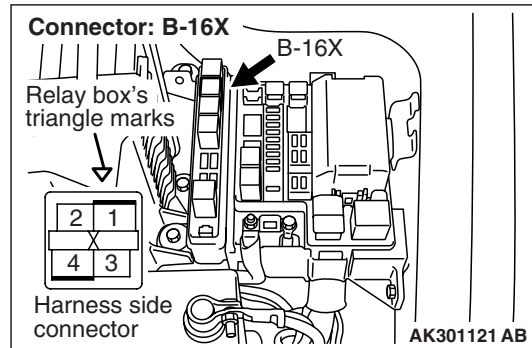

NOTE: Before checking harness, check intermediate connectors A-13*¹, C-111*² and C-12*¹, C-134*², and repair if necessary.

- Check power supply line for damage.

Q: Is the check result normal?

YES : Check and repair harness between A-09X (terminal No. 3) fan control relay connector and body earth.

- Check earthing line for damage.

NO : Repair.

STEP 12. Connector check: C-123 engine-ECU <M/T> or C-122 engine-A/T-ECU <A/T> connector

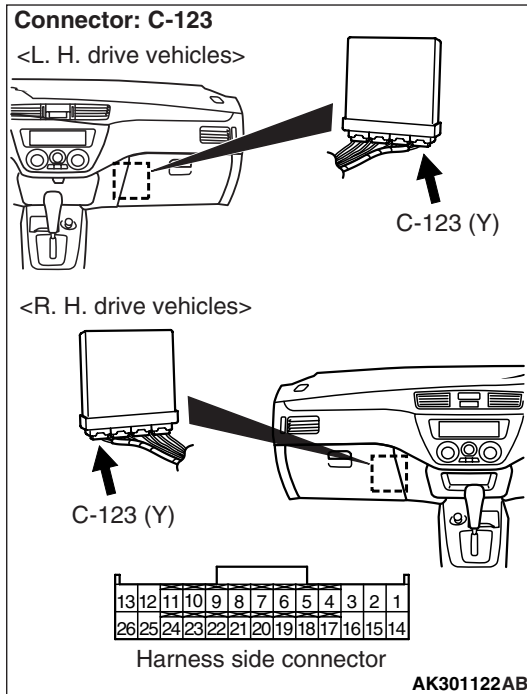

STEP 13. Fan motor drive test.

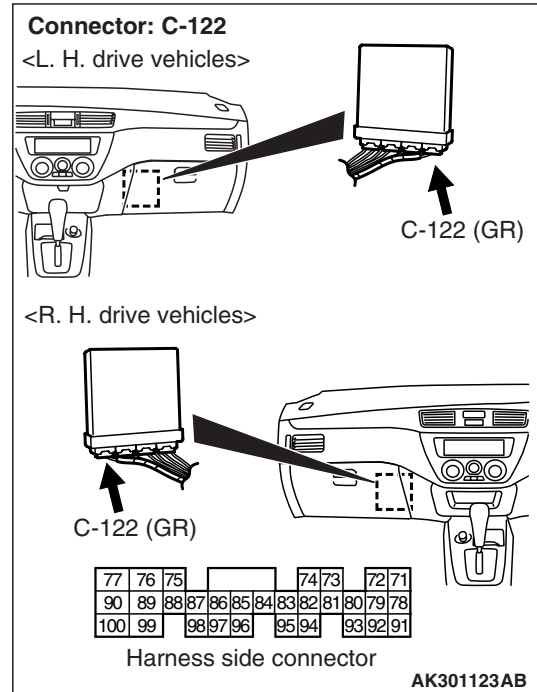
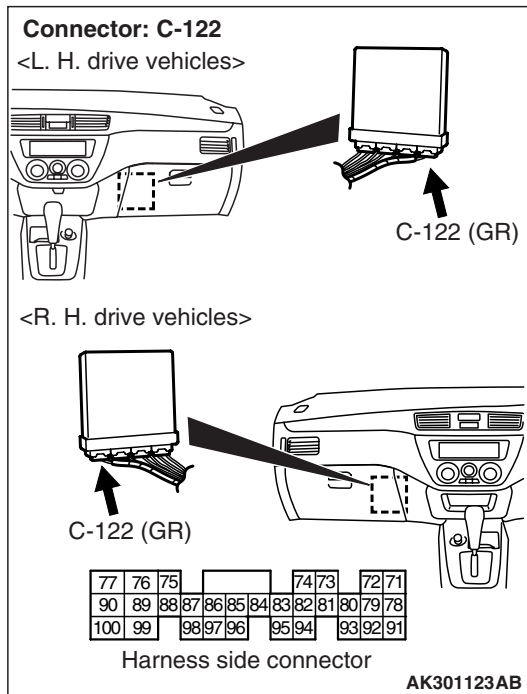
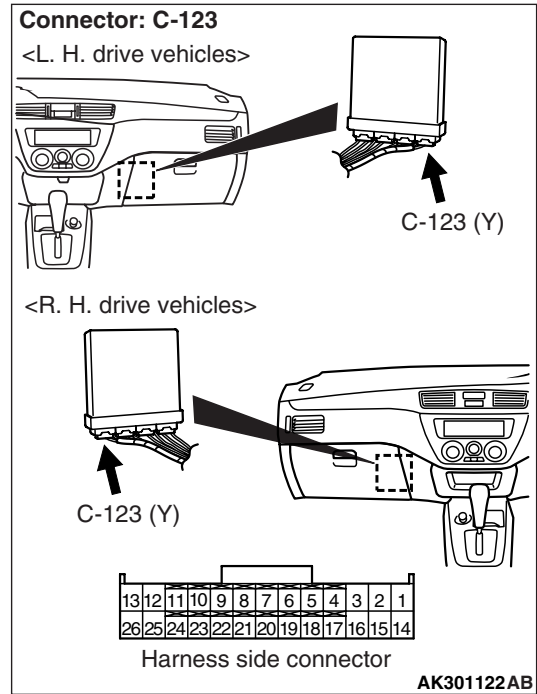

Q: Is the check result normal?

YES : Go to Step 13 .

NO : Repair or replace.

- Disconnect C-123 engine-ECU <M/T> or C-122 engine-A/T-ECU <A/T> connector.
- Ignition switch: ON

OK: Fan motor rotates.

Q: Is the check result normal?

YES : Go to Step 14 .

NO : Go to Step 15 .

STEP 14. M.U.T.-II/III actuator test

- Refer to actuator test reference table [P.13A-383](#).
 - a. Item 21: Fan controller

OK: Fan motor rotates.

Q: Is the check result normal?

YES : Intermittent malfunction (Refer to GROUP 00 –How to Use Troubleshooting/Inspection Service Points [P.00-5](#)).

NO : Replace engine-ECU <M/T> or engine-A/T-ECU <A/T>.

STEP 15. Perform voltage measurement at C-123 engine-ECU <M/T> connector or C-122 engine-A/T-ECU <A/T> connector.

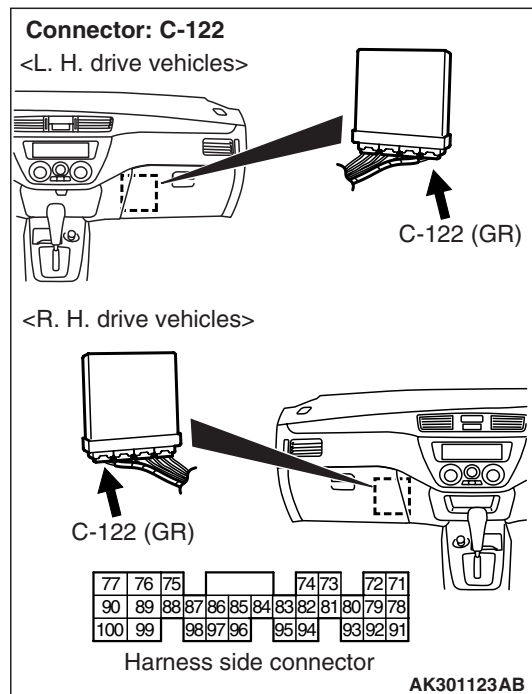
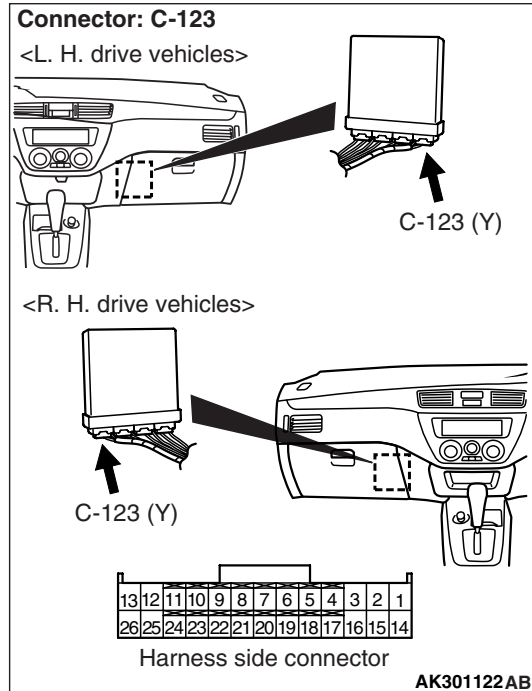

- Disconnect connector, and measure at harness side.
- Ignition switch: ON
- Voltage between terminal No. 21 <M/T> or terminal No. 18 <A/T> and earth.

OK: 4.9 – 5.1 V

Q: Is the check result normal?

YES : Go to Step 16 .

NO : Go to Step 18 .

STEP 16. Check harness between A-09X (terminal No. 4) fan control relay connector and battery.

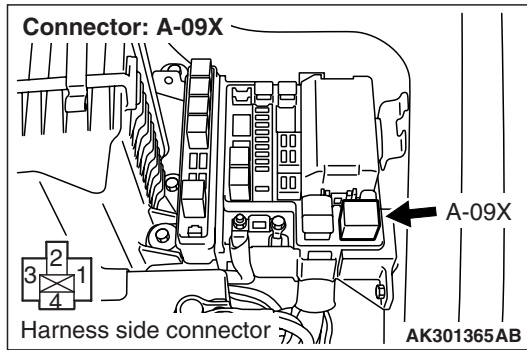

- Check power supply line for damage.

Q: Is the check result normal?

YES : Go to Step 17 .

NO : Repair.

STEP 17. Check harness between A-09X (terminal No. 2) fan control relay connector and A-18 (terminal No. 3) fan controller connector.

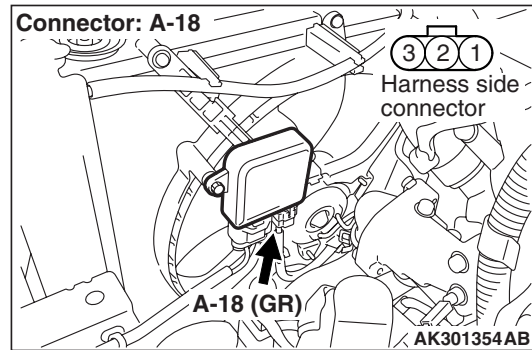
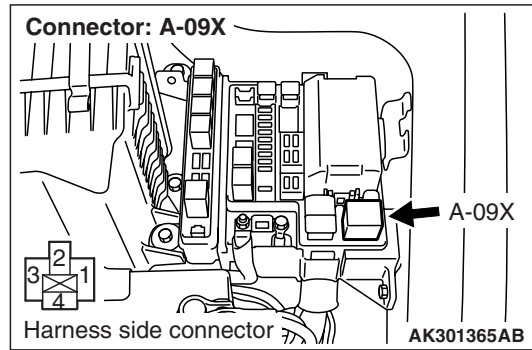

- Check output line for damage.

Q: Is the check result normal?

YES : Replace fan motor and fan controller.

NO : Repair.

STEP 18. Check harness between A-18 (terminal No. 2) fan controller connector and C-123 (terminal No. 21) engine-ECU <M/T> connector or C-122 (terminal No. 18) engine-A/T-ECU <A/T> connector.

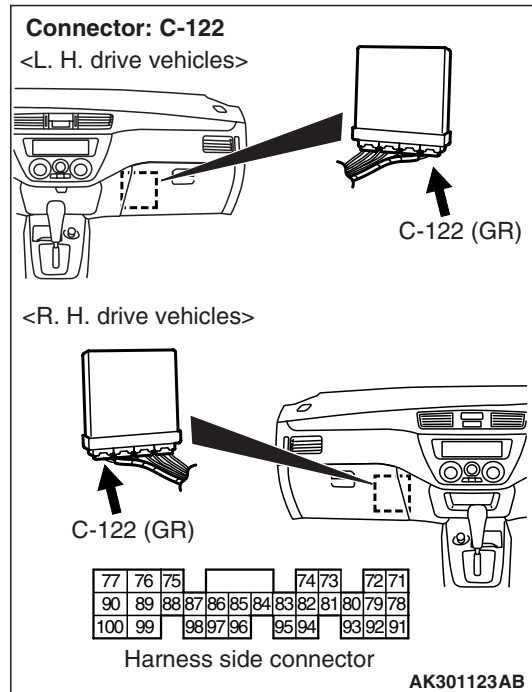
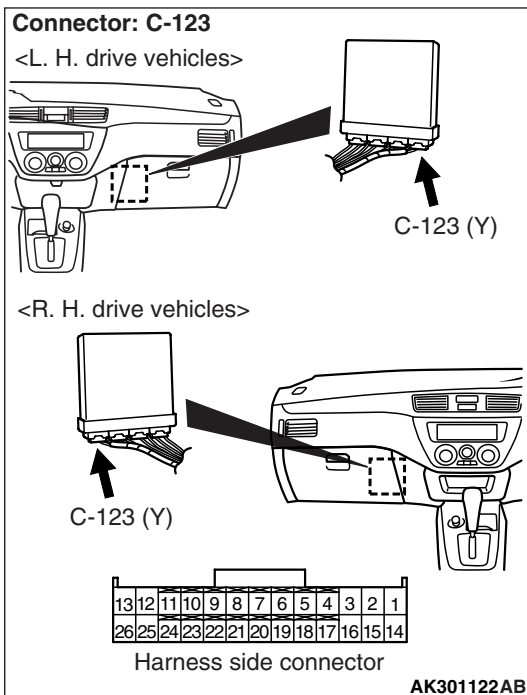
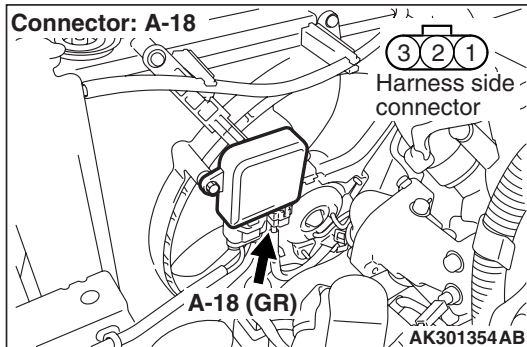

NOTE: Before checking harness, check intermediate connector A-13*¹, A-111*², and repair if necessary.

- Check output line for short circuit.

Q: Is the check result normal?

YES : Replace fan motor and fan controller.

NO : Repair.

Inspection Procedure 26: A/C System

A/C Circuit

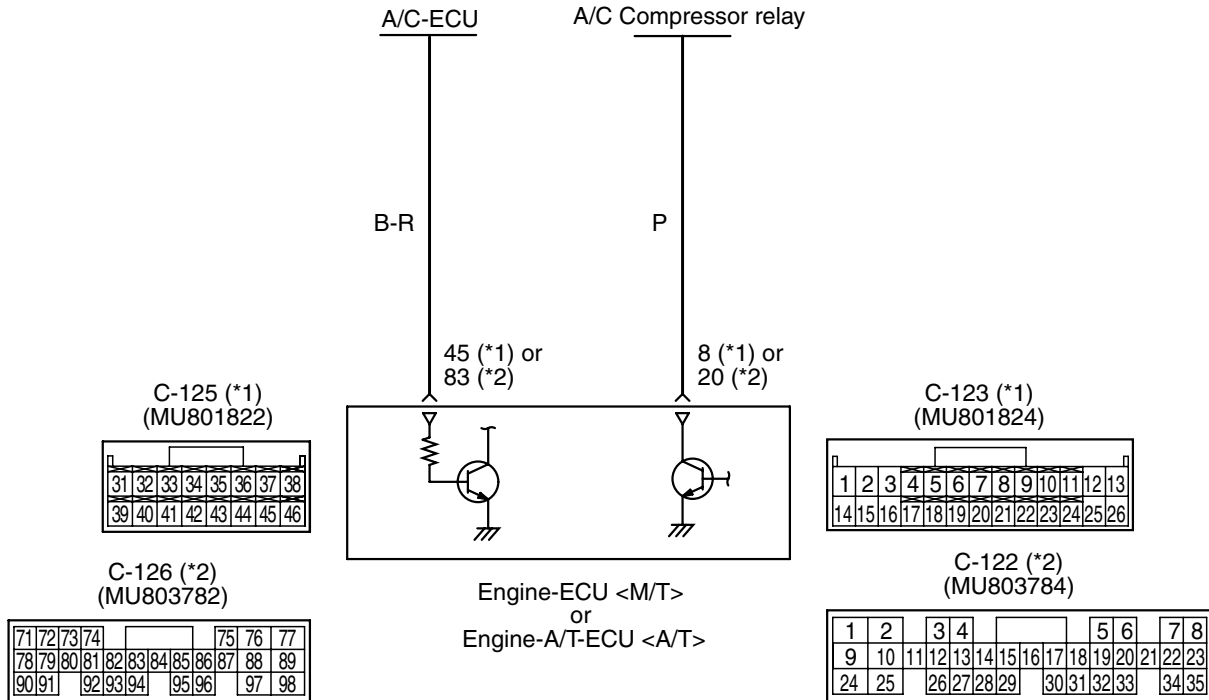

NOTE
*1: M/T
*2: A/T

Wire colour code

B: Black LG: Light green G: Green L: Blue W: White Y: Yellow SB: Sky blue BR: Brown O: Orange GR: Gray
R: Red P: Pink V: Violet

AK301366AB

OPERATION

- The battery voltage is applied to the engine-ECU (terminal No. 45) <M/T> or engine-A/T-ECU (terminal No. 83) <A/T> from the A/C-ECU.
- The engine-ECU (terminal No. 8) <M/T> or engine-A/T-ECU (terminal No. 20) <A/T> makes the power transistor in the unit be in "ON" position and makes currents go on the A/C compressor relay coil, and that makes the relay be in "ON" position.

FUNCTION

- When the A/C switch is in "ON" position, A/C switch ON signal is inputted to the engine-ECU <M/T> or engine-A/T-ECU <A/T> from the A/C-ECU. In response to the signal, the engine-ECU <M/T> or engine-A/T-ECU <A/T> controls the A/C compressor relay.

- When the A/C switch "ON" signal is inputted to the engine-ECU <M/T> or engine-A/T-ECU <A/T>, the engine-ECU <M/T> or engine-A/T-ECU <A/T> places the A/C compressor relay in the "ON" position. Accordingly, the battery voltage supplied to the A/C compressor operates the magnet clutch.

PROBABLE CAUSE

- Failed A/C
- Failed A/C system
- Open/short circuit in A/C circuit or loose connector contact
- Failed engine-ECU <M/T>
- Failed engine-A/T-ECU <A/T>

DIAGNOSIS PROCEDURE

STEP 1. Connector check: C-123 and C-125 engine-ECU <M/T> connector or C-122 and C-126 engine-A/T-ECU <A/T> connector

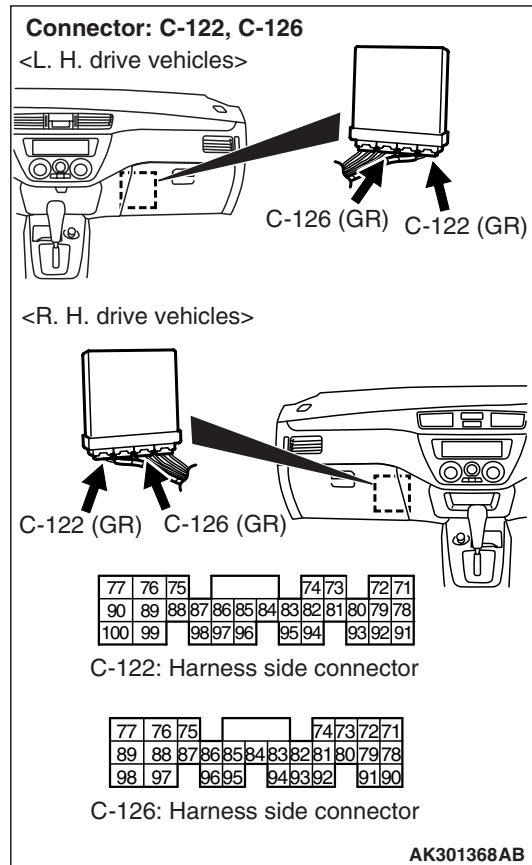
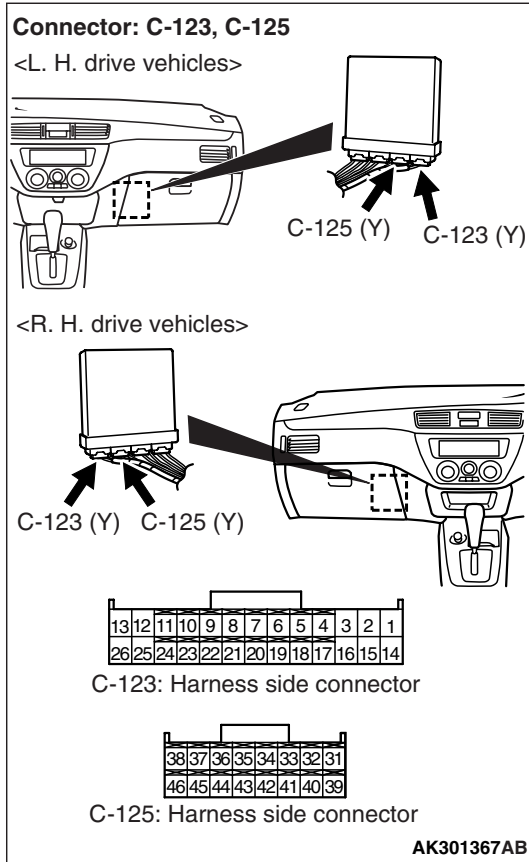

Q: Is the check result normal?
YES : Go to Step 2 .
NO : Repair or replace.

STEP 2. Perform voltage measurement at C-123 engine-ECU <M/T> connector or C-122 engine-A/T-ECU <A/T> connector.

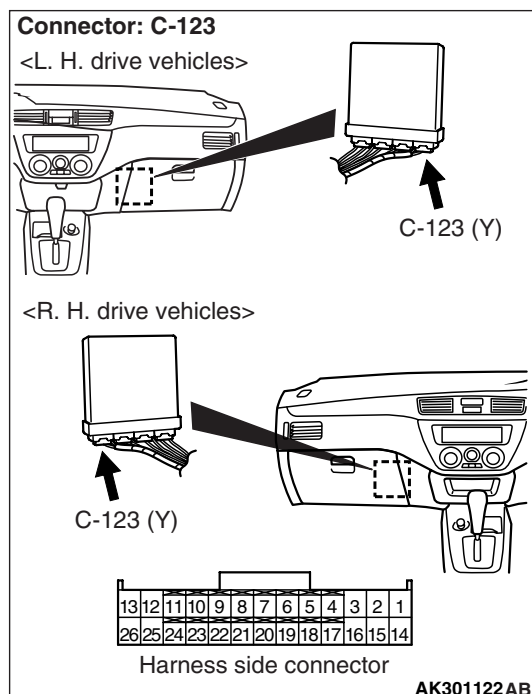

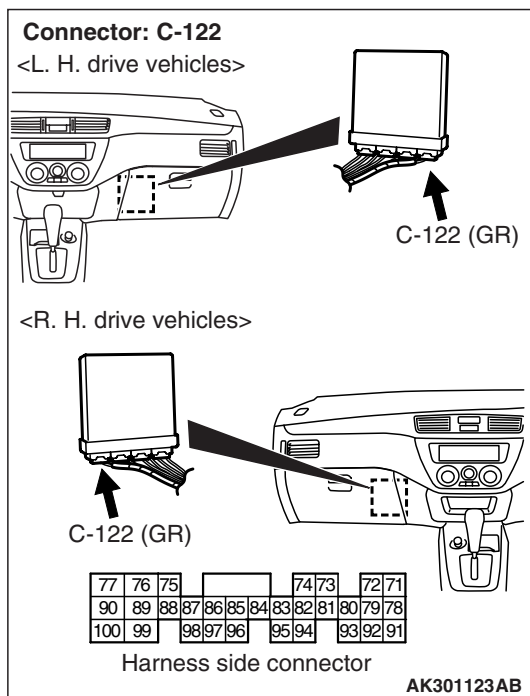

- Disconnect connector, and measure at harness side.
- Ignition switch: ON
- Voltage between terminal No. 8 <M/T> or terminal No. 20 <A/T> and earth.

OK: System voltage

- Using a jumper wire, connect terminal No. 8 <M/T> or terminal No. 20 <A/T>.

OK: A/C compressor relay should turn "ON"

Q: Is the check result normal?

YES : Go to Step 3 .

NO : Check Air conditioner (Refer to GROUP 55 – Troubleshooting P.55A-5).

STEP 3. Perform voltage measurement at C-125 engine-ECU <M/T> connector or C-126 engine-A/T-ECU <A/T> connector.

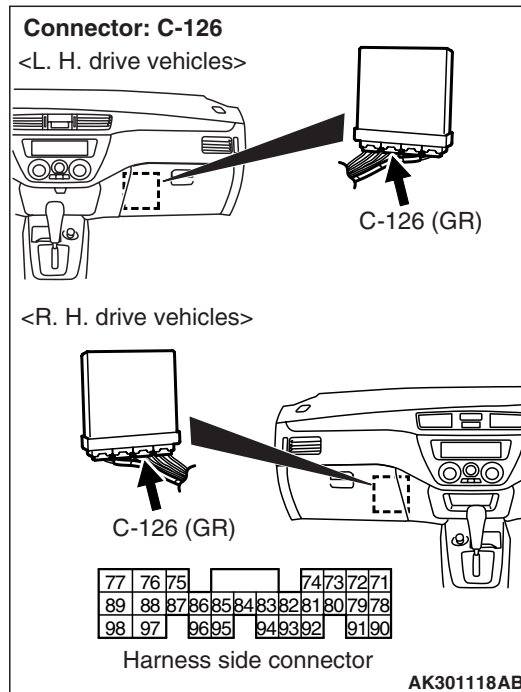
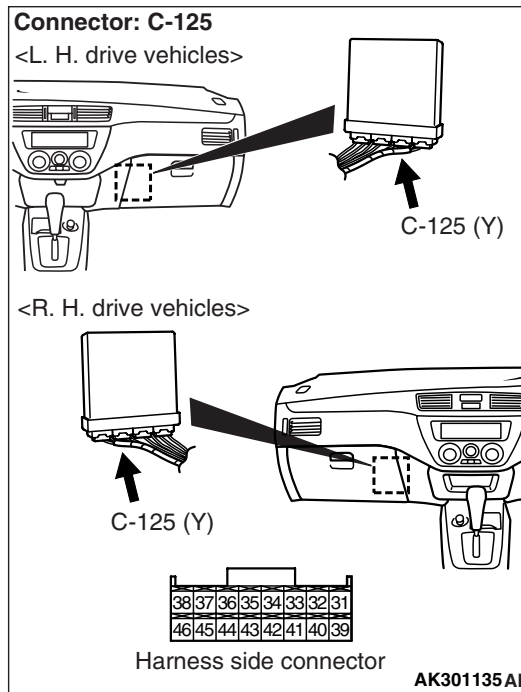

- Disconnect connector, and measure at harness side.
- Ignition switch: ON
- Voltage between terminal No. 45 <M/T> or terminal No. 83 <A/T> and earth.

OK:

**System voltage (when the A/C is ON)
0.5 V or less (when the A/C is OFF)**

Q: Is the check result normal?

YES : Replace the engine-ECU <M/T> or engine-A/T-ECU <A/T>.

NO : Check Air conditioner (Refer to GROUP 55 – Troubleshooting P.55A-5).

Inspection Procedure 27: A/C Load Signal System

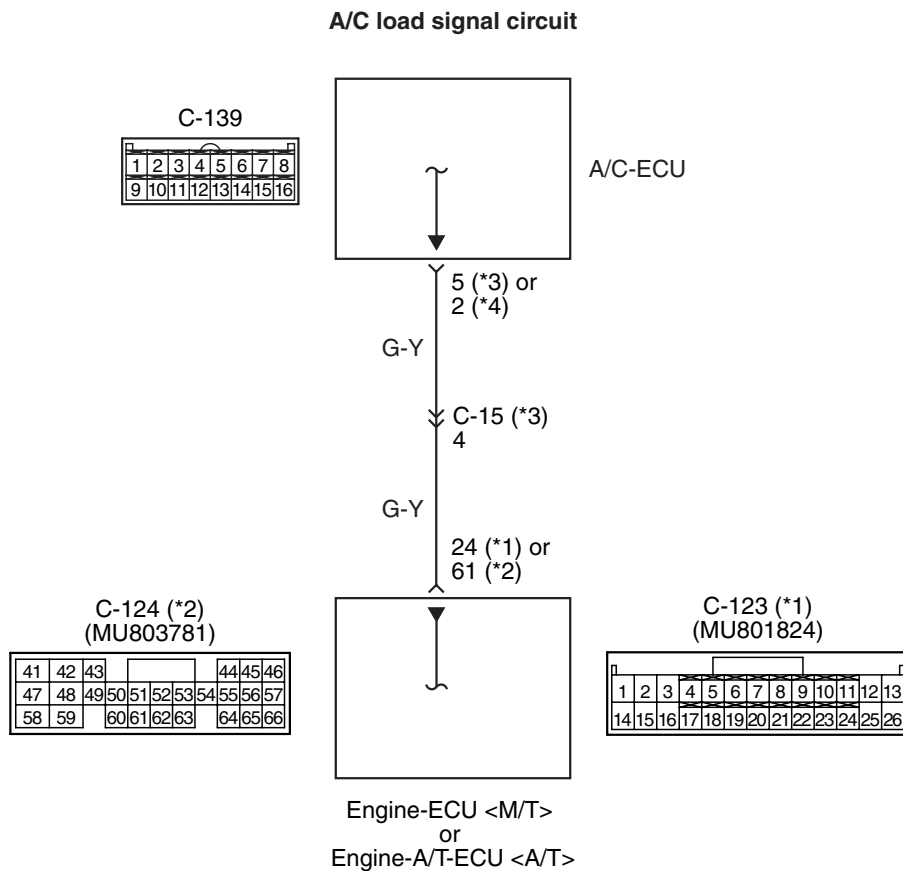

NOTE

- *1: M/T
- *2: A/T
- *3: L.H. drive vehicles
- *4: R.H. drive vehicles

Wire colour code

B: Black LG: Light green G: Green L: Blue W: White Y: Yellow SB: Sky blue BR: Brown O: Orange GR: Gray
R: Red P: Pink V: Violet

AK301369AC

OPERATION

- The A/C load signal is inputted to the engine-ECU (terminal No. 24) from the A/C-ECU (terminal No. 5) <L.H. drive vehicles> or (terminal No. 2) <R.H. drive vehicles>.

FUNCTION

- The magnitude of the A/C compressor load is detected and input to the engine-ECU <M/T> or engine-A/T-ECU <A/T>. The engine-ECU <M/T> or engine-A/T-ECU <A/T> provides A/C idle up control according to the A/C compressor load condition.

PROBABLE CAUSE

- Failed A/C-ECU
- Open/short circuit in A/C load signal circuit or loose connector contact
- Failed engine-ECU <M/T> or engine-A/T-ECU <A/T>

DIAGNOSIS PROCEDURE

NOTE:

- *1: L.H. drive vehicles
- *2: R.H. drive vehicles

STEP 1. Perform voltage measurement at C-123 engine-ECU <M/T> connector or C-124 engine-A/T-ECU <A/T> connector.

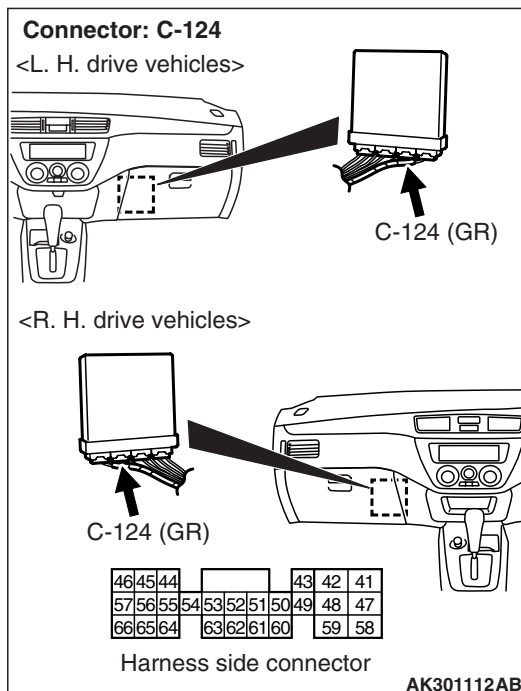
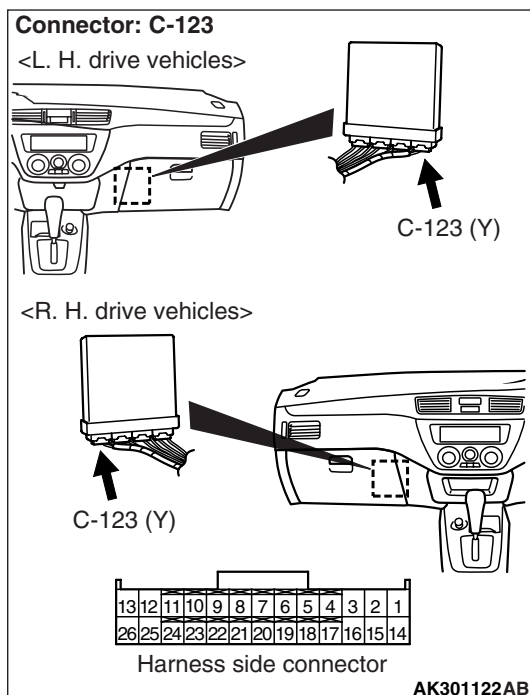

- Measure engine-ECU <M/T> or engine-A/T-ECU <A/T> terminal voltage.
- Engine: Idling
- A/C switch: ON (A/C compressor in driven state)
- Voltage between terminal No. 24 <M/T> or terminal No. 61 <A/T> and earth

OK:

**1 V or less (when the A/C is under high load)
System voltage (when the A/C is under high load)**

Q: Is the check result normal?

- YES :** Go to Step 2 .
- NO :** Go to Step 4 .

STEP 2. Connector check: C-123 engine-ECU <M/T> connector or C-124 engine-A/T-ECU <A/T> connector

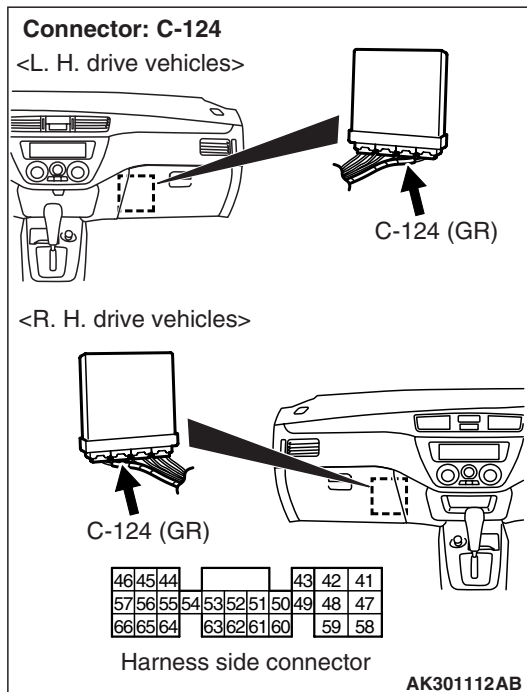
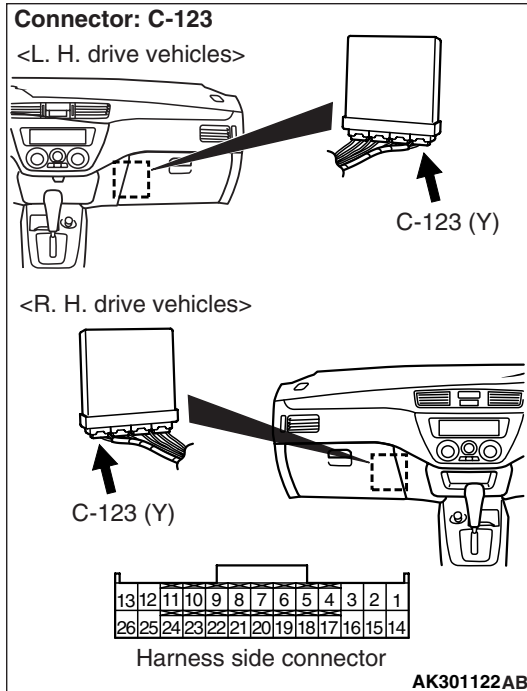

Q: Is the check result normal?
YES : Go to Step 3 .
NO : Repair or replace.

STEP 3. Check the trouble symptoms.

Q: Does trouble symptom persist?
YES : Replace engine-ECU <M/T> or engine-A/T-ECU <A/T>.
NO : Intermittent malfunction (Refer to GROUP 00 –How to Use Troubleshooting/Inspection Service Points P.00-5).

STEP 4. Connector check: C-123 engine-ECU <M/T> or C-124 engine-A/T-ECU <A/T> connector

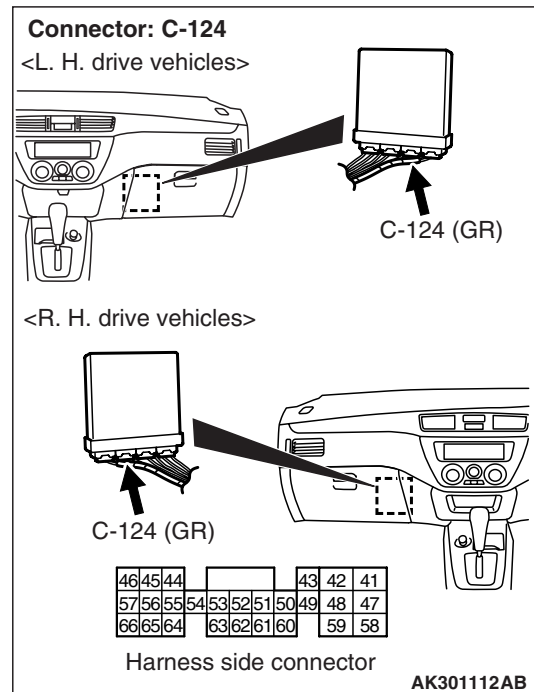
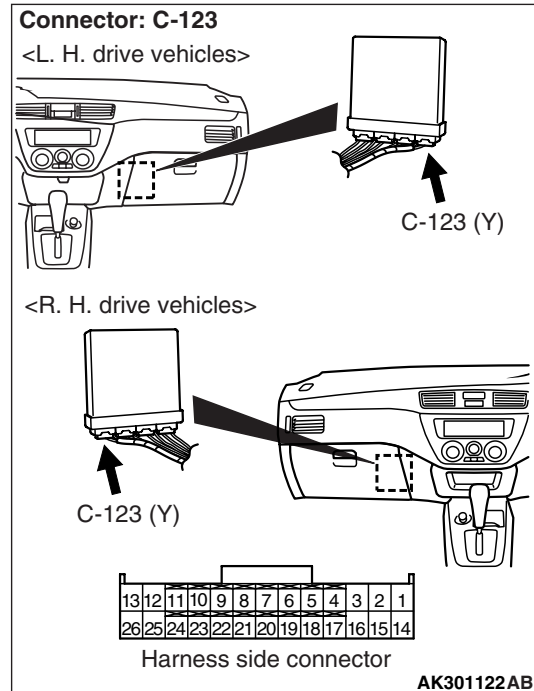

Q: Is the check result normal?

YES : Go to Step 5 .

NO : Repair or replace.

STEP 5. Perform voltage measurement at C-139 A/C-ECU connector.

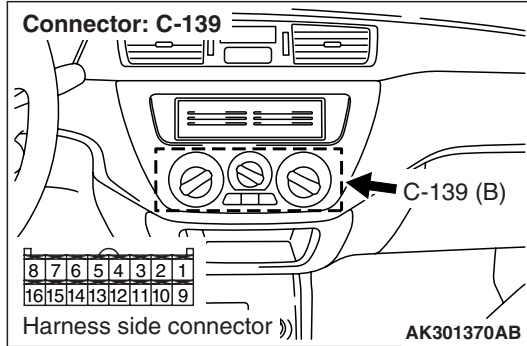

- Measure A/C-ECU terminal voltage.
- Engine: Idling
- A/C switch: ON (A/C compressor in drive state)
- Voltage between terminal No. 5*¹ or No. 2*² and earth

OK: System voltage (when the A/C is under high load)

Q: Is the check result normal?

YES : Go to Step 8 .

NO : Go to Step 6 .

STEP 6. Connector Check: C-139 A/C-ECU connector

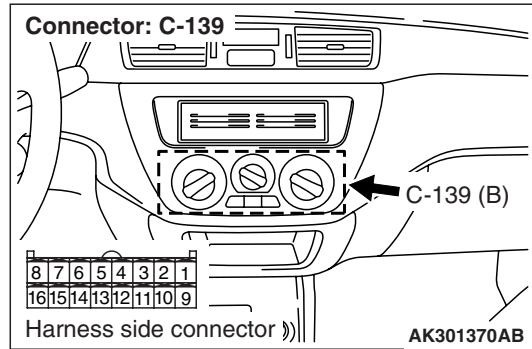

Q: Is the check result normal?

YES : Go to Step 7 .

NO : Repair or replace.

STEP 7. Check harness between C-139 (terminal No. 5*¹ or No. 4*²) and C-123 (terminal No. 24) engine-ECU <M/T> connector or C-124 (terminal No. 61) engine-A/T-ECU <A/T> connector.

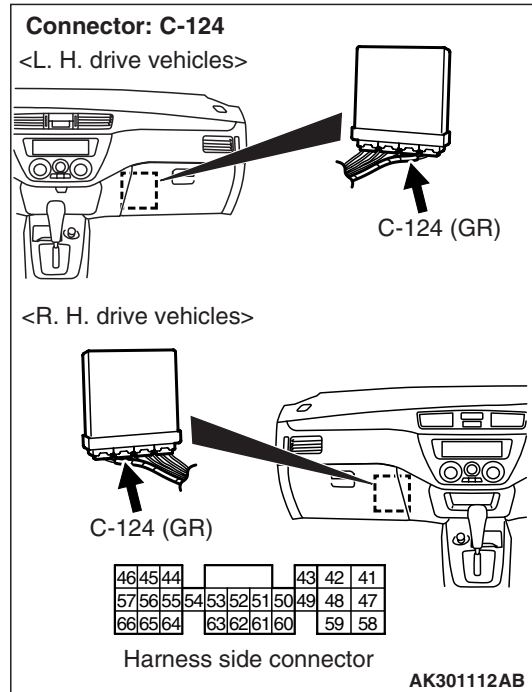
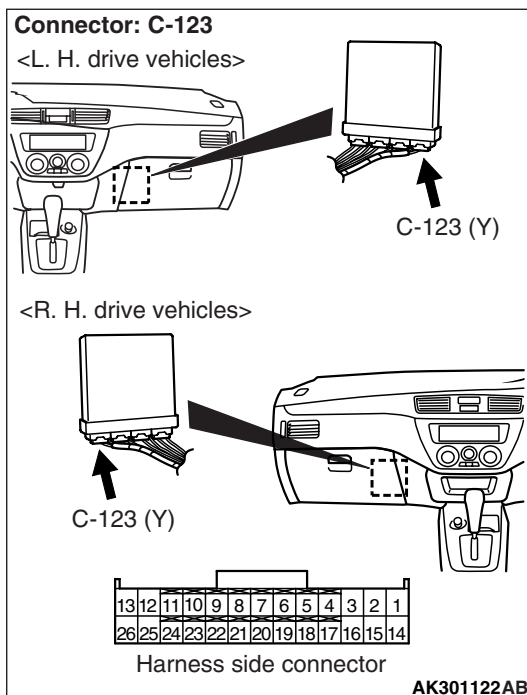
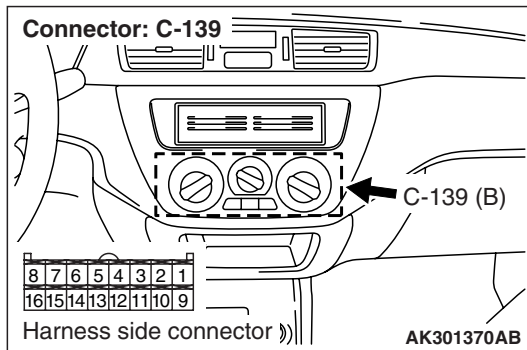

NOTE: Before checking harness, check intermediate connector C-15*¹, and repair if necessary.

- Check output line for short circuit.

Q: Is the check result normal?

- YES :** Check Air conditioner (Refer to GROUP 55 – Troubleshooting P.55A-5).
- NO :** Repair.

STEP 8. Check connector: C-139 A/C-ECU connector

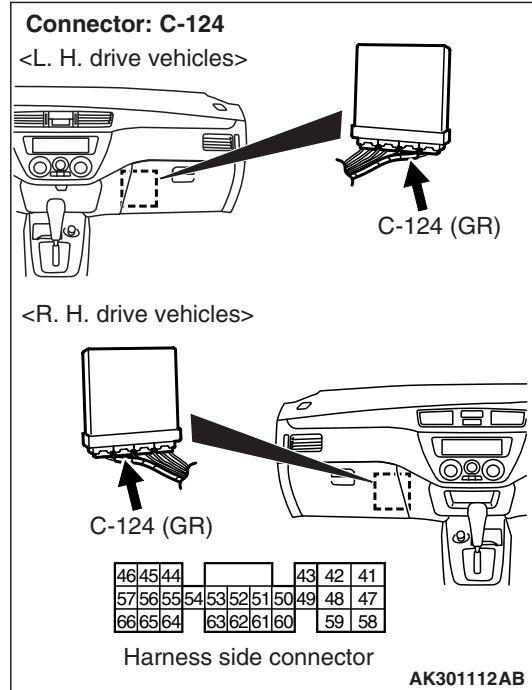
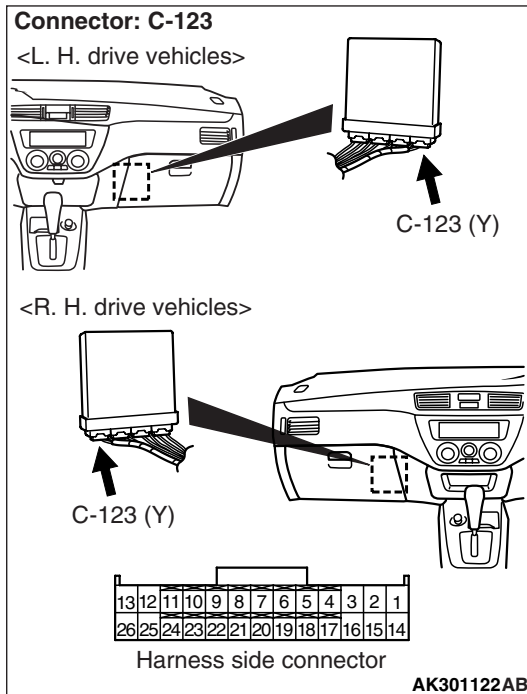
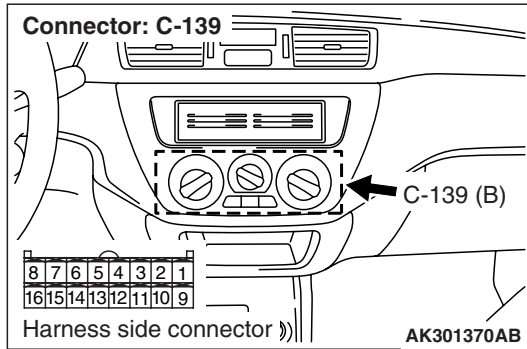

Q: Is the check result normal?

YES : Check intermediate connector C-15^{*1}, and repair if necessary. If intermediate connector is normal, check and repair harness between C-139 (terminal No. 5^{*1} or No. 2^{*2}) and C-123 (terminal No. 24) engine-ECU <M/T> connector or C-124 (terminal No. 61) engine-A/T-ECU <A/T> connector.

- Check output line for open circuit.

NO : Repair or replace.

Inspection Procedure 28: Ignition Circuit System <L. H. drive vehicles>

Ignition circuit

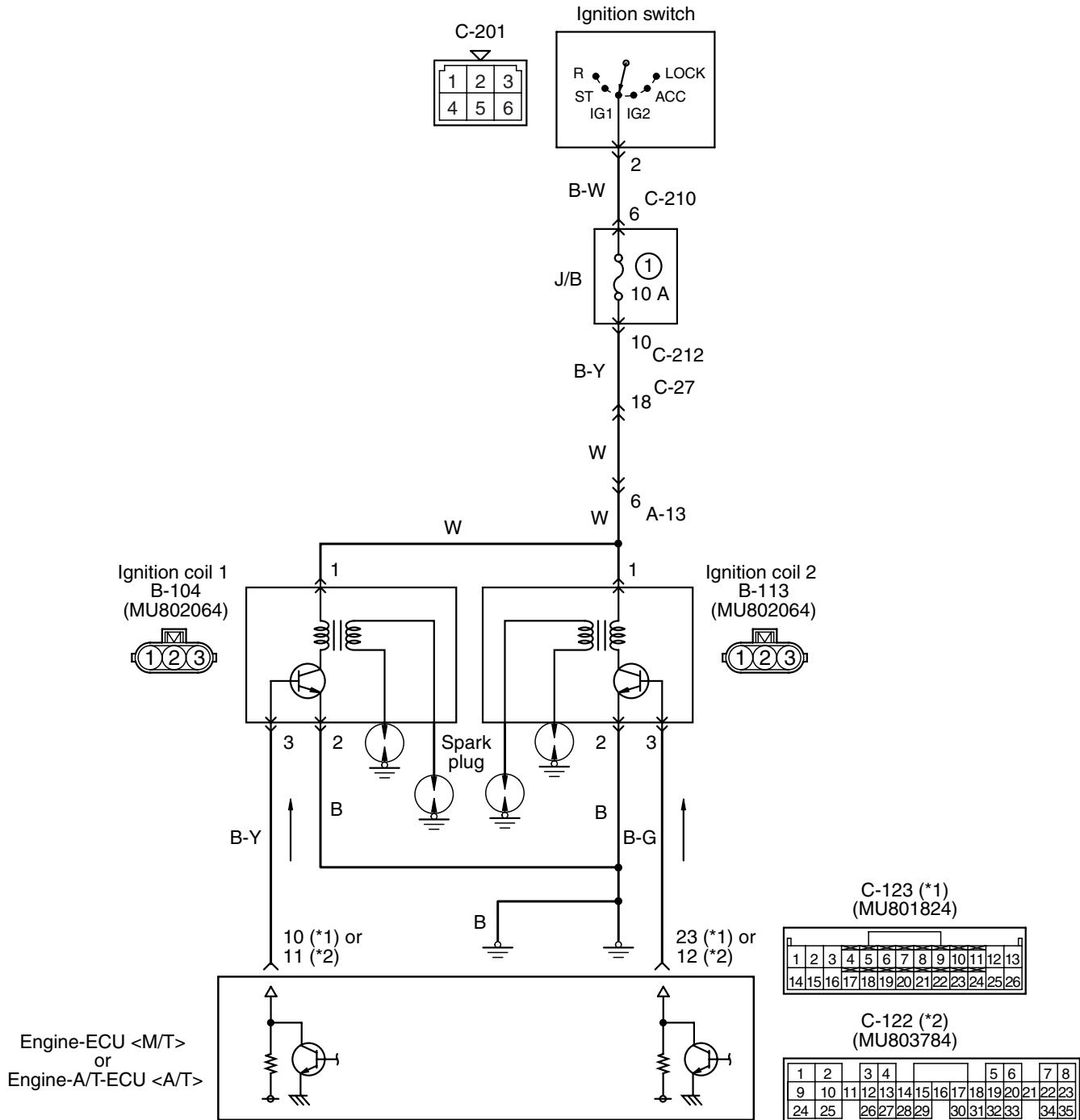

NOTE
*1: M/T
*2: A/T

Wire colour code
B: Black LG: Light green G: Green L: Blue W: White Y: Yellow SB: Sky blue BR: Brown O: Orange GR: Gray
R: Red P: Pink V: Violet

OPERATION

- The battery voltage is applied to the ignition coil (terminal No. 1) from the ignition switch and is earthed to the vehicle body from the ignition coil (terminal No. 2).
- A power voltage of 12 V is applied to the ignition coil output terminal (terminal No. 3) from the engine-ECU (terminal No. 10 and No. 23) <M/T> or engine-A/T-ECU (terminal No. 11 or No. 12) <A/T>.

FUNCTION

- When the engine-ECU <M/T> or engine-A/T-ECU <A/T> makes the power transistor in the unit be in "OFF" position, the battery voltage in the unit is applied to the power transistor unit, and that makes the power transistor unit be in "ON" position. The engine-ECU <M/T> or engine-A/T-ECU <A/T> makes the power transistor in the unit be in "ON", and that makes the power transistor unit be in "OFF" position.
- In response to the signal from the engine-ECU <M/T> or engine-A/T-ECU <A/T>, the power transistor unit is in "ON" position. The primary current is going to the ignition coil. When the power transistor unit is in "OFF" position, the primary current is interrupted and high voltage is generated in the secondary coil.

PROBABLE CAUSE

- Failed ignition coil
- Failed spark plug
- Failed resistive cord
- Open/short circuit in ignition primary circuit or loose connector contact
- Failed engine-ECU <M/T>
- Failed engine-A/T-ECU <A/T>

DIAGNOSIS PROCEDURE**STEP 1. Check resistive cord itself.**

- Check resistive cord itself (Refer to GROUP 16 – Ignition System –On-vehicle Service P.16-30).

Q: Is the check result normal?

YES : Go to Step 2 .

NO : Replace resistive cord.

STEP 2. Check spark plug.

Q: Is the check result normal?

YES : Go to Step 3 .

NO : Replace spark plug.

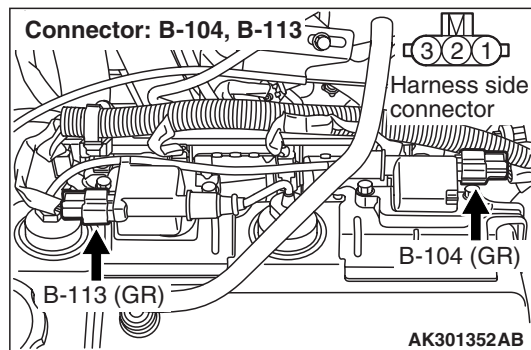
STEP 3. Connector check: B-104 and B-113 ignition coil connectors.

Q: Is the check result normal?

YES : Go to Step 4 .

NO : Repair or replace.

STEP 4. Check ignition coil itself.

- Check ignition coil itself (Refer to GROUP 16 – Ignition System –On-vehicle Service P.16-30).

Q: Is the check result normal?

YES : Go to Step 5 .

NO : Replace ignition coil.

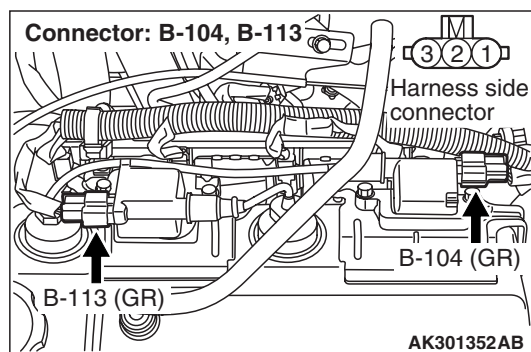
STEP 5. Perform voltage measurement at B-104 and B-113 ignition coil connectors.

- Disconnect connector, and measure at harness side.
- Ignition switch: ON
- Voltage between terminal No. 1 and earth.

OK: System voltage

Q: Is the check result normal?

YES : Go to Step 7 .

NO : Go to Step 6 .

STEP 6. Connector check: C-201 ignition switch connector

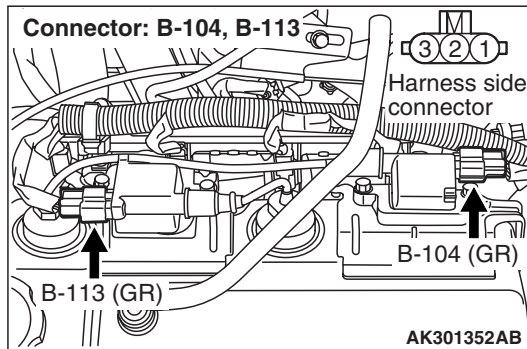
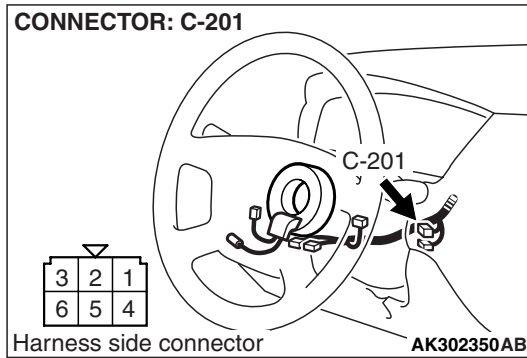

Q: Is the check result normal?

YES : Check intermediate connectors A-13, C-27, C-212 and C-210, and repair if necessary. If intermediate connectors are normal, check and repair harness between C-201 (terminal No. 2) ignition switch connector and B-113 (terminal No. 1) ignition coil connector, also between C-201 (terminal No. 2) ignition switch connector and B-104 (terminal No. 1) ignition coil connector.

- Check power supply line for open/short circuit.

NO : Repair or replace.

STEP 7. Perform voltage measurement at B-104 and B-113 ignition coil connectors.

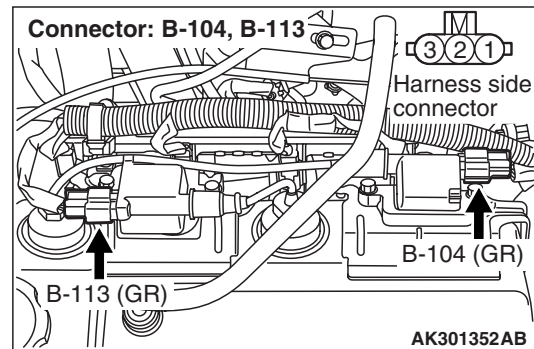

- Disconnect connector, and measure at harness side.
- Engine: Cranking
- Voltage between terminal No. 3 and earth.

OK: 0.5 – 4.0 V

Q: Is the check result normal?

YES : Go to Step 13 .

NO : Go to Step 8 .

STEP 8. Perform voltage measurement at C-123 engine-ECU <M/T> connector or C-122 engine-A/T-ECU <A/T> connector.

STEP 9. Connector check: C-123 engine-ECU <M/T> connector or C-122 engine-A/T-ECU <A/T> connector

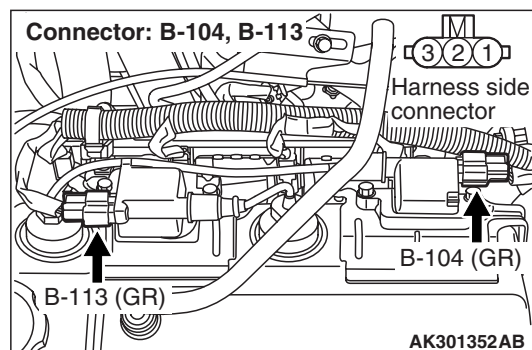
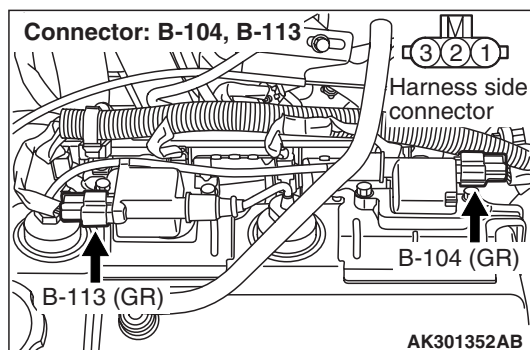
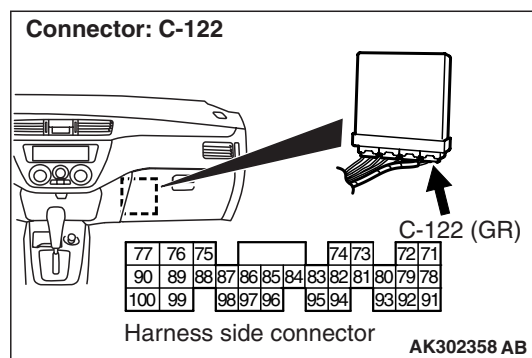
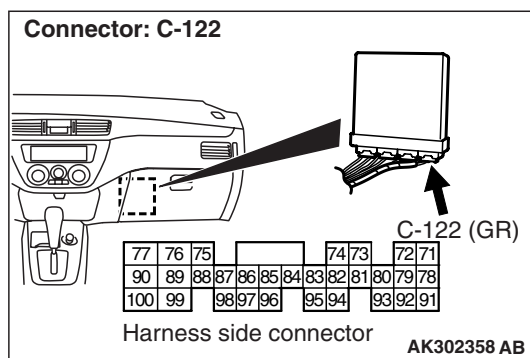
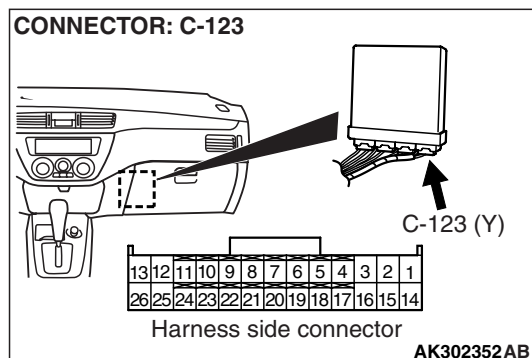
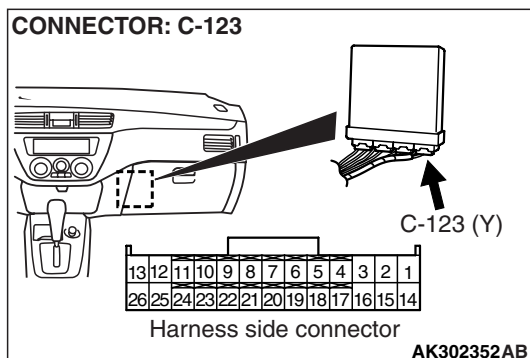

- Measure engine-ECU <M/T> or engine-A/T-ECU <A/T> terminal voltage.
- Disconnect B-104 and B-113 ignition coil connectors.
- Engine: Cranking
- Voltage between terminal No. 10 <M/T> or terminal No. 11 <A/T> and earth, also between terminal No. 23 <M/T> or terminal No. 12 <A/T> and earth.

OK: 0.5 – 4.0 V

Q: Is the check result normal?

YES : Go to Step 9 .

NO : Go to Step 10 .

Q: Is the check result normal?

YES : Check and repair harness between B-113 (terminal No. 3) ignition coil connector and C-123 (terminal No. 23) engine-ECU <M/T> connector or C-122 (terminal No. 12) engine-A/T-ECU <A/T> connector, also between B-104 (terminal No. 3) ignition coil connector and C-122 (terminal No. 10) engine-ECU <M/T> connector or C-122 (terminal No. 11) engine-A/T-ECU <A/T> connector.

- Check output line for open circuit.

NO : Repair or replace.

STEP 10. Connector check: C-123 engine-ECU <M/T> connector or C-122 engine-A/T-ECU <A/T> connector

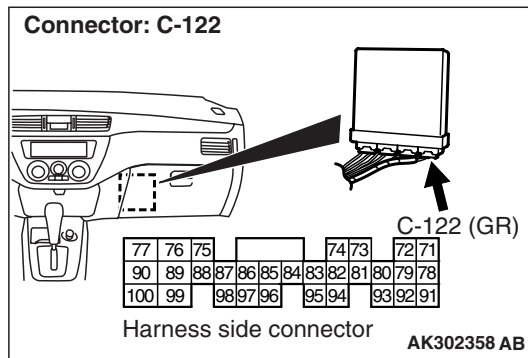
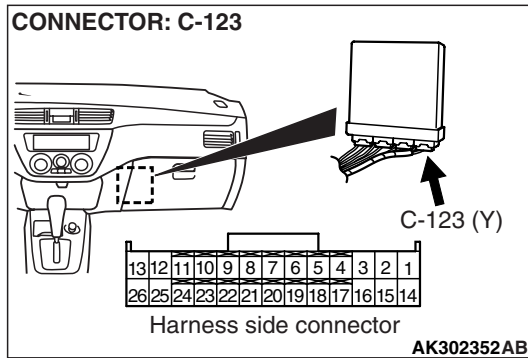

Q: Is the check result normal?
YES : Go to Step 11 .
NO : Repair or replace.

STEP 11. Check harness between B-113 (terminal No. 3) ignition coil connector and C-123 (terminal No. 23) engine-ECU <M/T> connector or C-122 (terminal No. 12) engine-A/T-ECU <A/T> connector, also between B-104 (terminal No. 3) ignition coil connector and C-123 (terminal No. 10) engine-ECU <M/T> connector or C-122 (terminal No. 11) engine-A/T-ECU <A/T> connector.

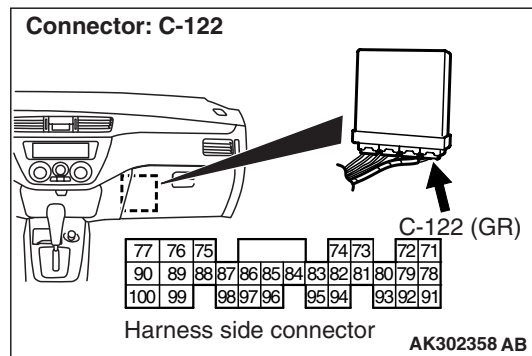
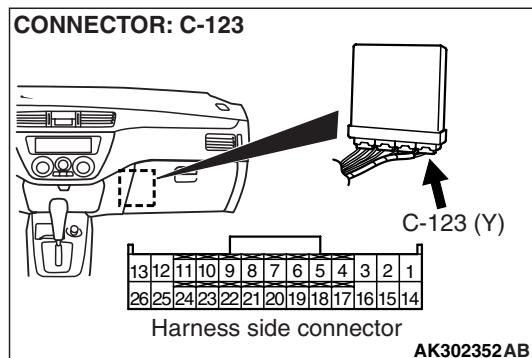
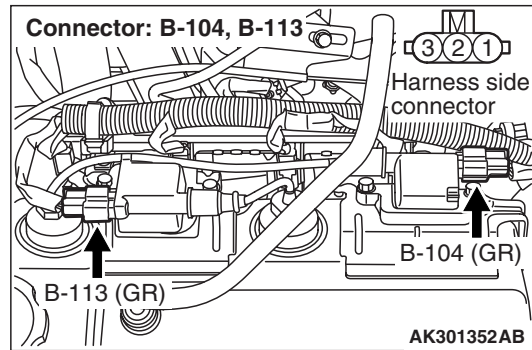

- Check output line for short circuit.

Q: Is the check result normal?
YES : Go to Step 12 .
NO : Repair.

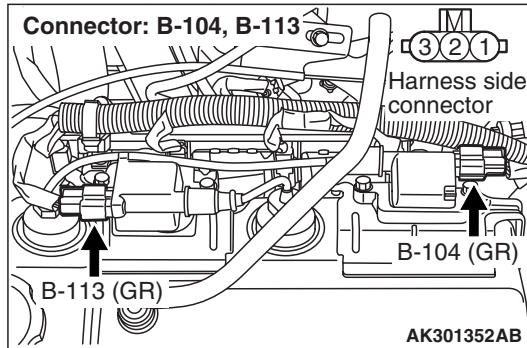
STEP 12. Check the trouble symptoms.**Q: Does trouble symptom persist?****YES :** Replace engine-ECU <M/T> or engine-A/T-ECU <A/T>.**NO :** Intermittent malfunction (Refer to GROUP 00 –How to Use Troubleshooting/Inspection Service Points P.00-5).**STEP 13. Perform resistance measurement at B-104 and B-113 ignition coil connectors.**

- Disconnect connector, and measure at harness side.
- Resistance between terminal No. 2 and earth.

OK: Continuity (2 Ω or less)**Q: Is the check result normal?****YES :** Go to Step 14 .**NO :** Check and repair harness between B-104 (terminal No. 2) ignition coil connector and body earth, also between B-113 (terminal No. 2) ignition coil connector and body earth.

- Check earthing line for open circuit and damage.

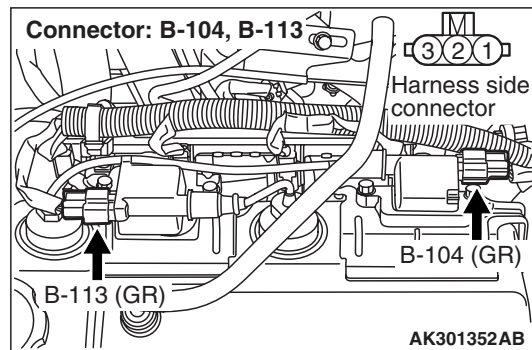
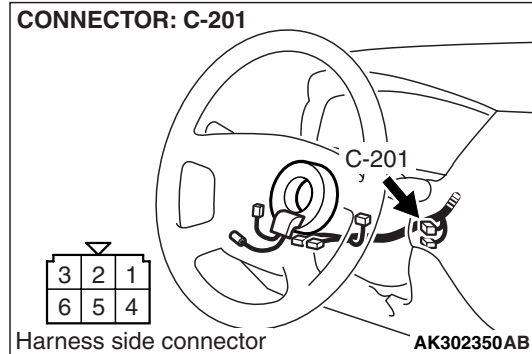
STEP 14. Check harness between C-201 (terminal No. 2) ignition switch connector and B-104 (terminal No. 1) ignition coil connector, also between C-201 (terminal No. 2) ignition switch connector and B-113 (terminal No. 1) ignition coil connector.**NOTE:** Before checking harness, check intermediate connectors A-13, C-27, C-212 and C-210, and repair if necessary.

- Check power supply line for damage.

Q: Is the check result normal?**YES :** Go to Step 15 .**NO :** Repair.

STEP 15. Check harness between B-113 (terminal No. 3) ignition coil connector and C-123 (terminal No. 23) engine-ECU <M/T> connector or C-122 (terminal No. 12) engine-A/T-ECU <A/T> connector, also between B-104 (terminal No. 3) ignition coil connector and C-123 (terminal No. 10) engine-ECU <M/T> connector or C-122 (terminal No. 11) engine-A/T-ECU <A/T> connector.

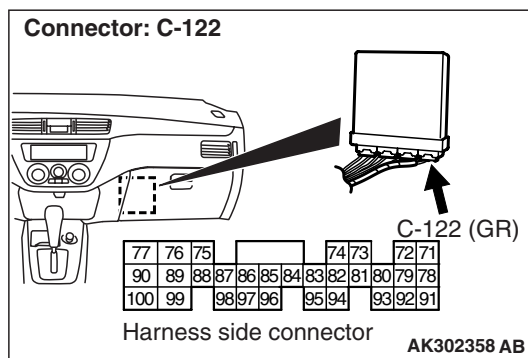
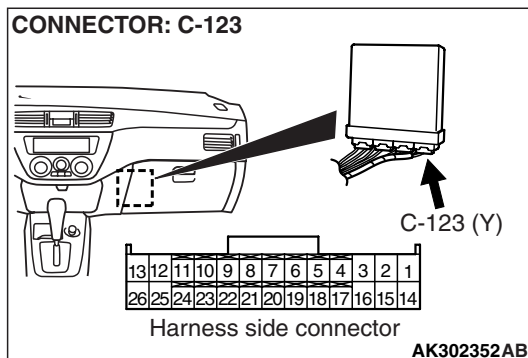
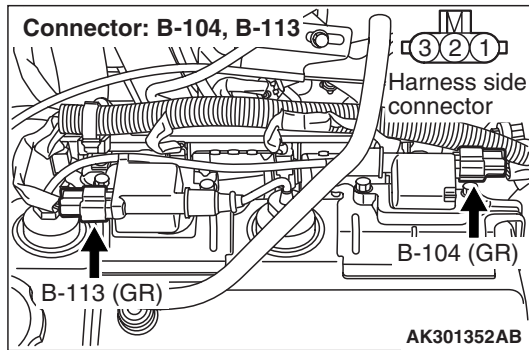

- Check output line for damage.

Q: Is the check result normal?

YES : Go to Step 12 .

NO : Repair.

Inspection Procedure 29: Ignition Circuit System <R.H. drive vehicles>

Ignition circuit

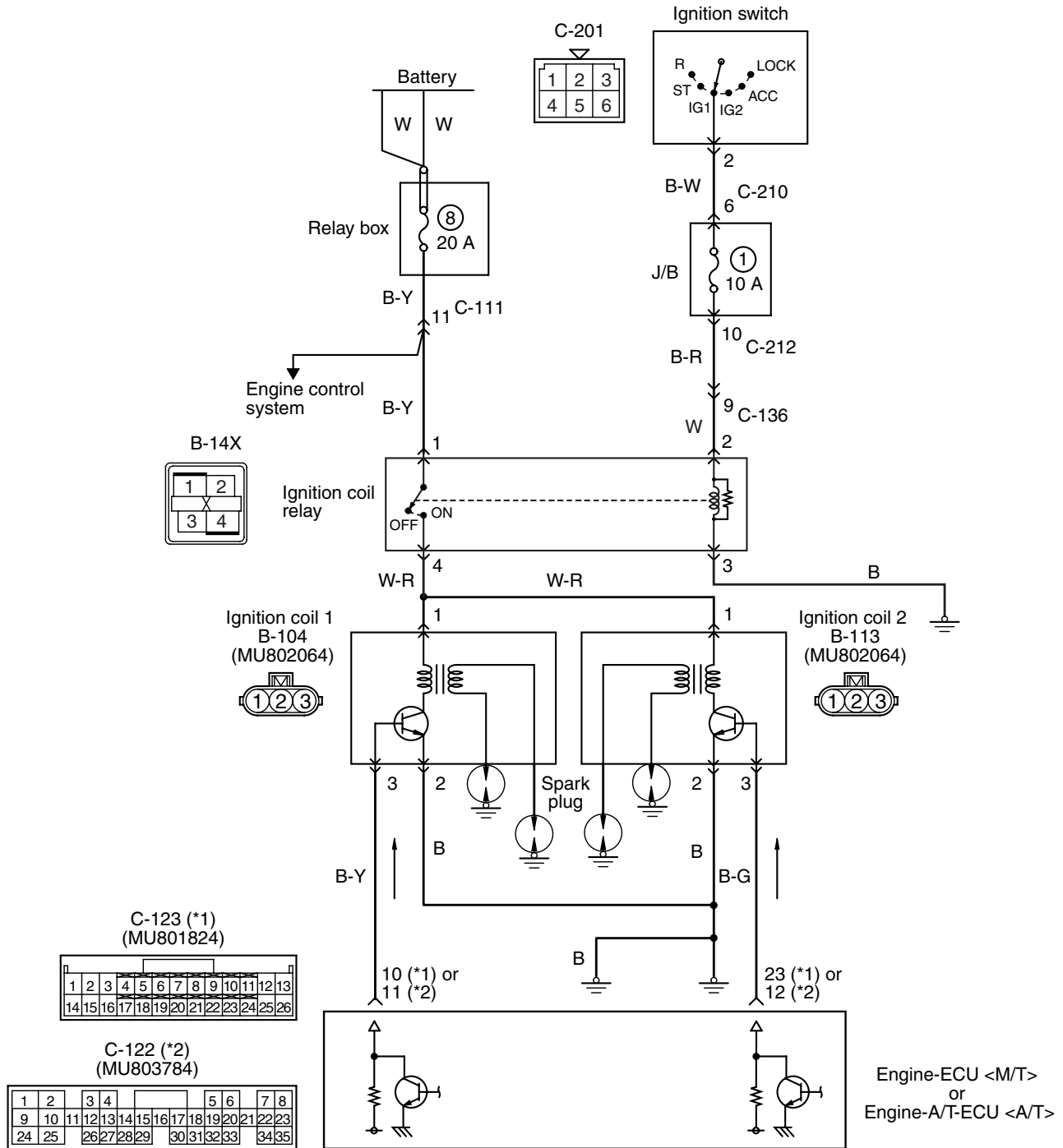

NOTE
*1: M/T
*2: A/T

Wire colour code
B: Black LG: Light green G: Green L: Blue W: White Y: Yellow SB: Sky blue BR: Brown O: Orange GR: Gray
R: Red P: Pink V: Violet

OPERATION

- The battery voltage is applied to the ignition coil relay (terminal No. 2) from the ignition switch and is earthed to the vehicle body from the ignition coil relay (terminal No. 3).
- The battery voltage is applied to the ignition coil relay (terminal No. 1) from the battery and is earthed to the vehicle body from the ignition coil relay (terminal No. 2).
- A power voltage of 12 V is applied to the ignition coil output terminal (terminal No. 3) from the engine-ECU (terminal No. 10 and No. 23) or engine-A/T-ECU (terminal No. 11 and No. 12).

FUNCTION

- When the engine-ECU <M/T> or engine-A/T-ECU <A/T> makes the power transistor in the unit be in "OFF" position, the battery voltage in the unit is applied to the power transistor unit, and that makes the power transistor unit be in "ON" position. The engine-ECU <M/T> or engine-A/T-ECU <A/T> makes the power transistor in the unit be in "ON", and that makes the power transistor unit be in "OFF" position.
- In response to the signal from the engine-ECU <M/T> or engine-A/T-ECU <A/T>, the power transistor unit is in "ON" position. The primary current is going to the ignition coil. When the power transistor unit is in "OFF" position, the primary current is interrupted and high voltage is generated in the secondary coil.

PROBABLE CAUSE

- Failed ignition coil
- Failed ignition coil relay
- Failed spark plug
- Failed resistive cord
- Open/short circuit in ignition primary circuit or loose connector contact
- Failed engine-ECU <M/T>
- Failed engine-A/T-ECU <A/T>

DIAGNOSIS PROCEDURE

STEP 1. Check resistive cord itself.

- Check resistive cord itself (Refer to GROUP 16 – Ignition System –On-vehicle Service P.16-30).

Q: Is the check result normal?

YES : Go to Step 2 .

NO : Replace resistive cord.

STEP 2. Check spark plug.

Q: Is the check result normal?

YES : Go to Step 3 .

NO : Replace spark plug.

STEP 3. Connector check: B-104 and B-113 ignition coil connectors

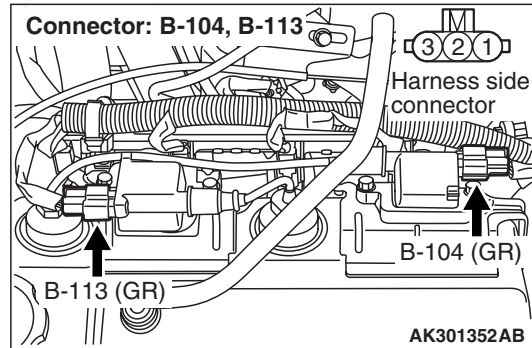

Q: Is the check result normal?

YES : Go to Step 4 .

NO : Repair or replace.

STEP 4. Check ignition coil itself.

- Check ignition coil itself (Refer to GROUP 16 – Ignition System –On-vehicle Service P.16-30).

Q: Is the check result normal?

YES : Go to Step 5 .

NO : Replace ignition coil.

STEP 5. Perform voltage measurement at B-104 and B-113 ignition coil connectors.

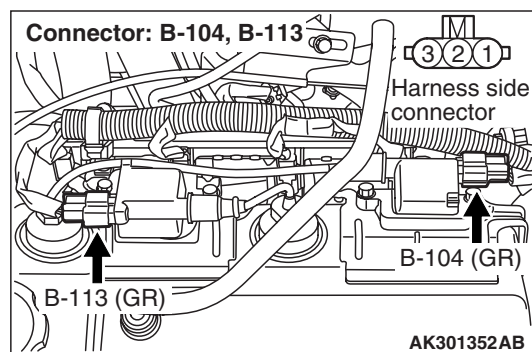

- Disconnect connector, and measure at harness side.
- Ignition switch: ON
- Voltage between terminal No. 1 and earth.

OK: System voltage

Q: Is the check result normal?

YES : Go to Step 12 .

NO : Go to Step 6 .

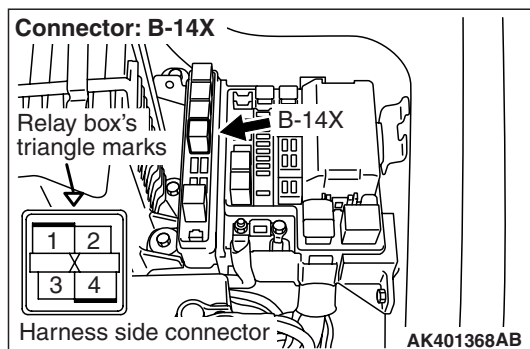
STEP 6. Connector check: B-14X ignition coil relay connectors**Q: Is the check result normal?****YES :** Go to Step 7 .**NO :** Repair or replace.**STEP 7. Check ignition coil relay.**

- Check ignition coil relay (Refer to GROUP 16 – Ignition System –On-vehicle Service P.16-35).

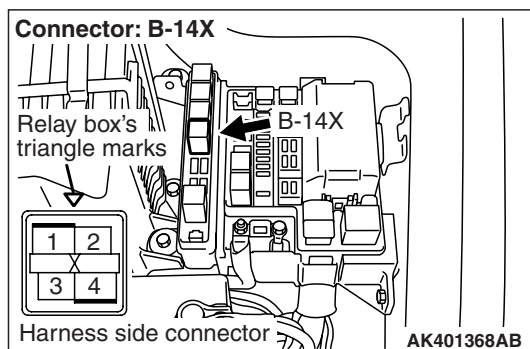
Q: Is the check result normal?**YES :** Go to Step 8 .**NO :** Replace ignition coil relay.**STEP 8. Perform voltage measurement at B-14X ignition coil relay connector.**

- Remove relay, and measure at relay box side.
- Ignition switch: ON
- Voltage between terminal No.2 and earth.

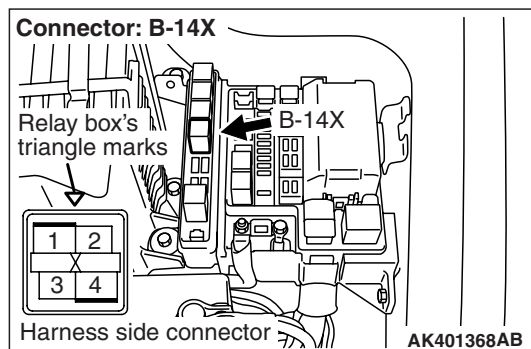
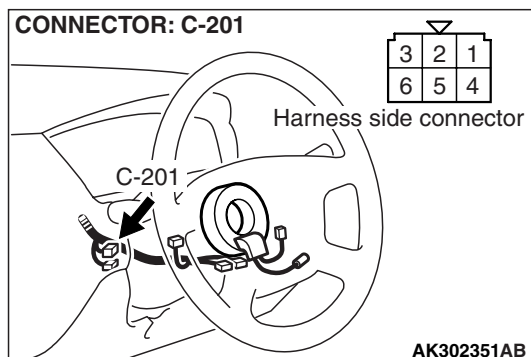
OK: System voltage**Q: Is the check result normal?****YES :** Go to Step 10 .**NO :** Go to Step 9 .**STEP 9. Connector check: C-201 ignition switch connector****Q: Is the check result normal?**

YES : Check intermediate connectors C-136, C-210 and C-212, and repair if necessary. If intermediate connectors are normal, check and repair harness between C-201 (terminal No. 2) ignition switch connector and B-14X (terminal No. 2) ignition coil relay connector.

- Check power supply line for open/short circuit.

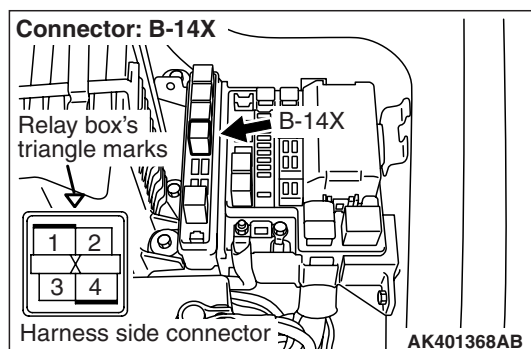
NO : Repair or replace.**STEP 10. Perform resistance measurement at B-14X ignition coil relay connector.**

- Remove relay, and measure at relay box side.
- Resistance between terminal No.3 and earth.

OK: Continuity (2 Ω or less)

Q: Is the check result normal?

YES : Go to Stop 11 .

NO : Check and repair harness between B-14X (terminal No.3) ignition coil relay connector and body earth.

- Check earthing line for open circuit and damage.

STEP 11. Perform voltage measurement at B-14X ignition coil relay connector.

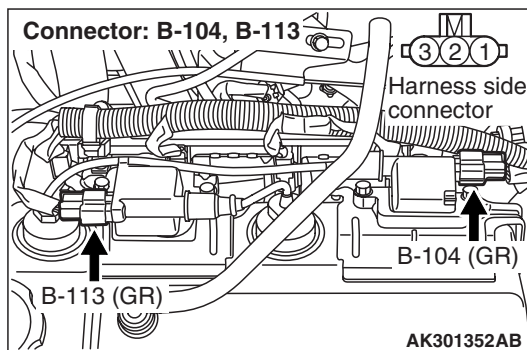
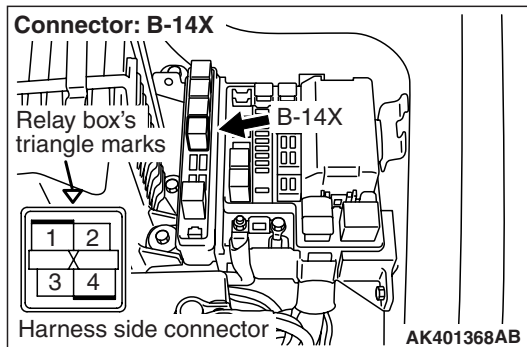

- Remove relay, and measure at relay box side.
- Voltage between terminal No.1 and earth.

OK: System voltage

Q: Is the check result normal?

YES : Check and repair harness between B-14X (terminal No.4) ignition coil relay connector and B-104 (terminal No.1) ignition coil connector, also between B-14X (terminal No.4) ignition coil relay connector and B-113 (terminal No.1) ignition coil connector.

- Check power supply line for open/short circuit and damage.

NO : Check intermediate connector C-111 and repair if necessary. If intermediate connector is normal, check and repair harness between B-14X (terminal No.1) ignition coil connector and battery.

- Check power supply line for open/short circuit and damage.

STEP 12. Perform voltage measurement at B-104 and B-113 ignition coil connectors.

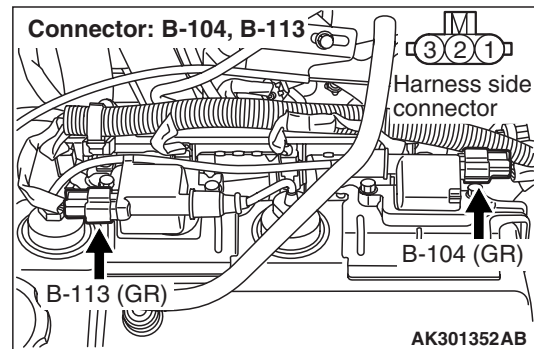

- Disconnect connector, and measure at harness side.
- Engine: Cranking
- Voltage between terminal No. 3 and earth.

OK: 0.5 – 4.0 V

Q: Is the check result normal?

YES : Go to Step 18 .

NO : Go to Step 13 .

STEP 13. Perform voltage measurement at C-123 engine-ECU <M/T> connector or C-122 engine-A/T-ECU <A/T> connector.

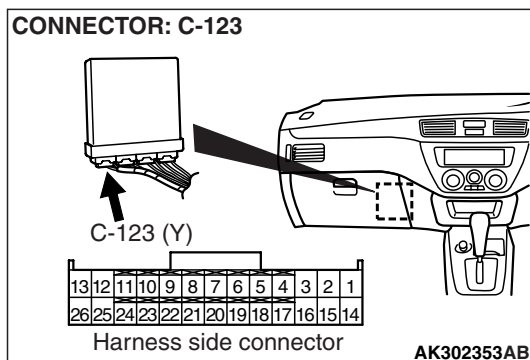

STEP 14. Connector check: C-123 engine-ECU <M/T> connector or C-122 engine-A/T-ECU <A/T> connector

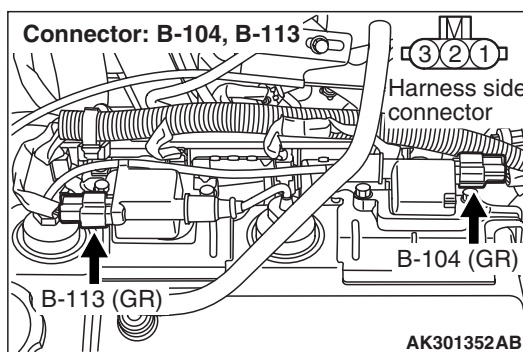
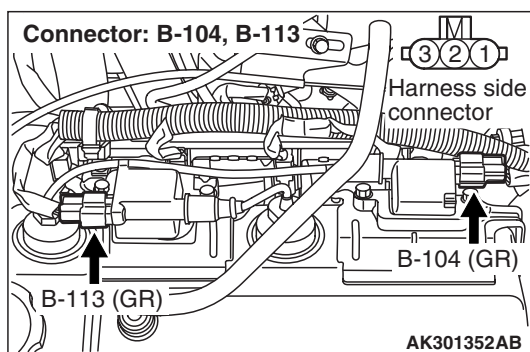
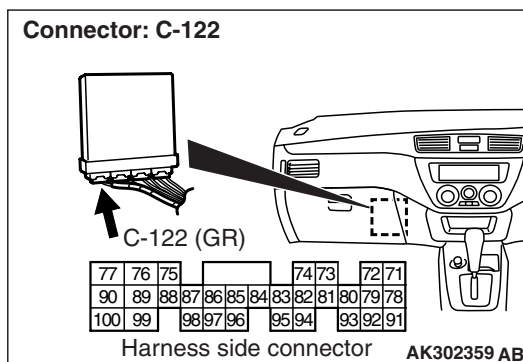
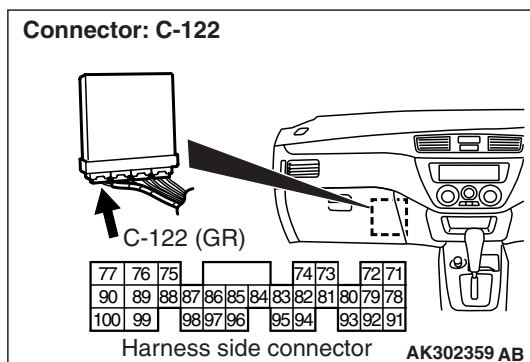
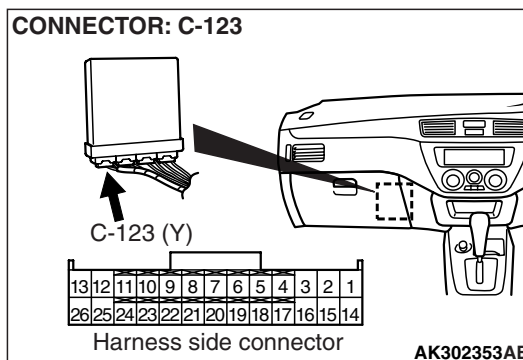

- Measure engine-ECU <M/T> or engine-A/T-ECU <A/T> terminal voltage.
- Disconnect B-104 and B-113 ignition coil connectors.
- Engine: Cranking
- Voltage between terminal No. 10 <M/T> or terminal No. 11 <A/T> and earth, also between terminal No. 23 <M/T> or terminal No. 12 <A/T> and earth.

OK: 0.5 – 4.0 V

Q: Is the check result normal?

YES : Go to Step 14 .

NO : Go to Step 15 .

Q: Is the check result normal?

YES : Check and repair harness between B-113 (terminal No. 3) ignition coil connector and C-123 (terminal No. 23) engine-ECU <M/T> connector or C-122 (terminal No. 12) engine-A/T-ECU <A/T> connector, also between B-104 (terminal No. 3) ignition coil connector and C-123 (terminal No. 10) engine-ECU <M/T> connector or C-122 (terminal No. 11) engine-A/T-ECU <A/T> connector.

- Check output line for open circuit.

NO : Repair or replace.

STEP 15. Connector check: C-123 engine-ECU <M/T> connector or C-122 engine-A/T-ECU <A/T> connector

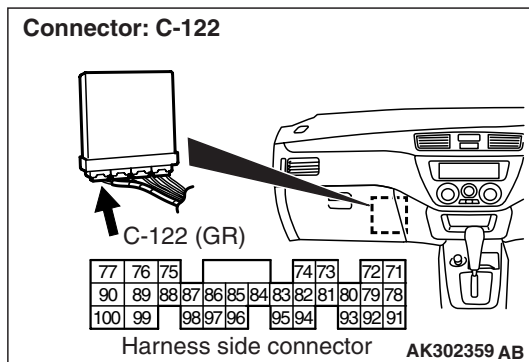
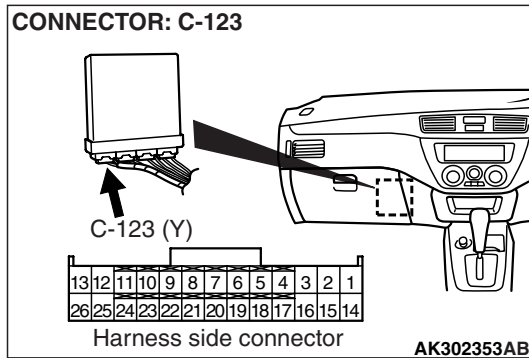

Q: Is the check result normal?

YES : Go to Step 11 .

NO : Repair or replace.

STEP 16. Check harness between B-113 (terminal No. 3) ignition coil connector and C-123 (terminal No. 23) engine-ECU <M/T> connector or C-122 (terminal No. 12) engine-A/T-ECU <A/T> connector, also between B-104 (terminal No. 3) ignition coil connector and C-123 (terminal No. 10) engine-ECU <M/T> connector or C-122 (terminal No. 11) engine-A/T-ECU <A/T> connector.

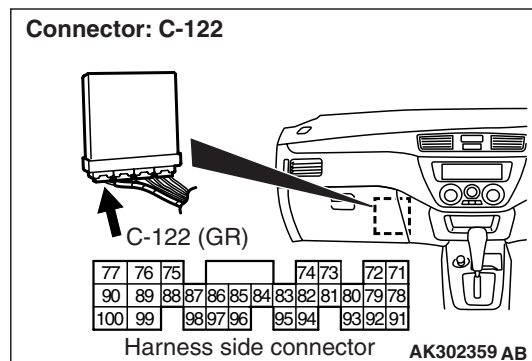
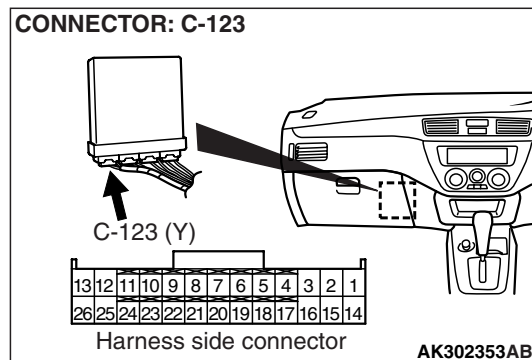
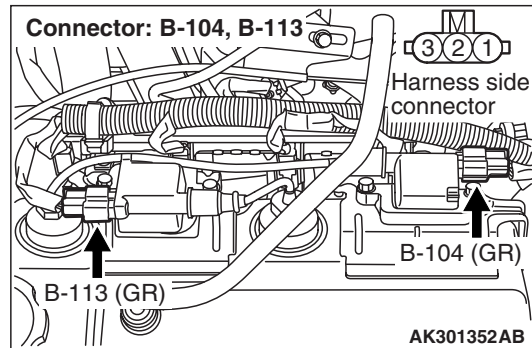

- Check output line for short circuit.

Q: Is the check result normal?

YES : Go to Step 17 .

NO : Repair.

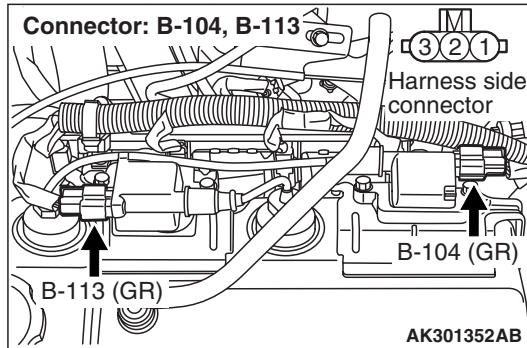
STEP 17. Check the trouble symptoms.**Q: Does trouble symptom persist?****YES :** Replace engine-ECU <M/T> or engine-A/T-ECU <A/T>.**NO :** Intermittent malfunction (Refer to GROUP 00 –How to Use Troubleshooting/Inspection Service Points P.00-5).**STEP 18. Perform resistance measurement at B-104 and B-113 ignition coil connectors.**

- Disconnect connector, and measure at harness side.
- Resistance between terminal No. 2 and earth.

OK: Continuity (2 Ω or less)**Q: Is the check result normal?****YES :** Go to Step 19 .**NO :** Check and repair harness between B-104 (terminal No. 2) ignition coil connector and body earth, also between B-113 (terminal No. 2) ignition coil connector and body earth.

- Check earthing line for open circuit and damage.

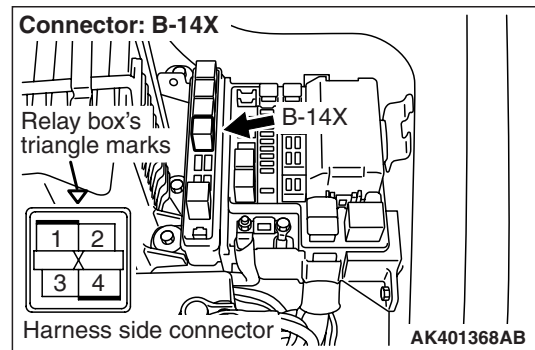
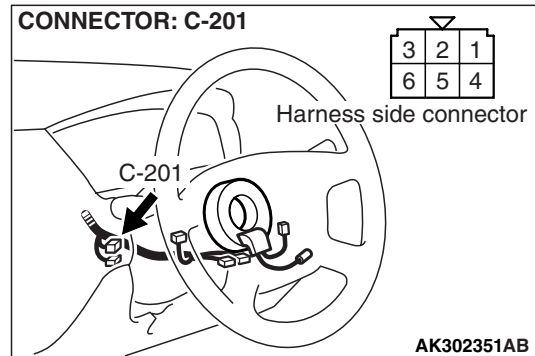
STEP 19. Check harness between C-201 (terminal No. 2) ignition switch connector and B-14X (terminal No. 2) ignition coil relay connector.**NOTE:** Before checking harness, check intermediate connectors C-136, C-212 and C-210, and repair if necessary.

- Check power supply line for damage.

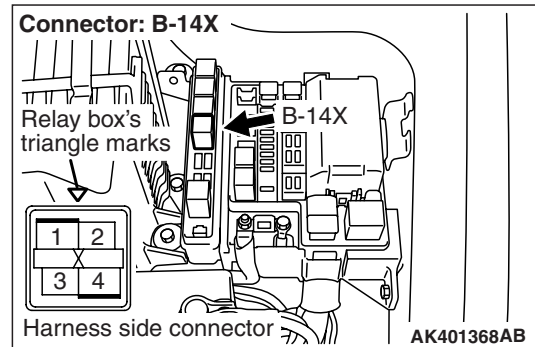
Q: Is the check result normal?**YES :** Go to Step 20 .**NO :** Repair.**STEP 20. Check harness between battery and B-14X (terminal No. 1) ignition coil relay connector.****NOTE:** Before checking harness, check intermediate connector C-111 and repair if necessary.

- Check power supply line for damage.

Q: Is the check result normal?**YES :** Go to Step 21 .**NO :** Repair.

STEP 21. Check harness between B-14X (terminal No. 4) ignition coil relay connector and B-104 (terminal No. 1) ignition coil connector, also between B-14X (terminal No. 4) ignition coil relay connector and B-113 (terminal No. 1) ignition coil connector.

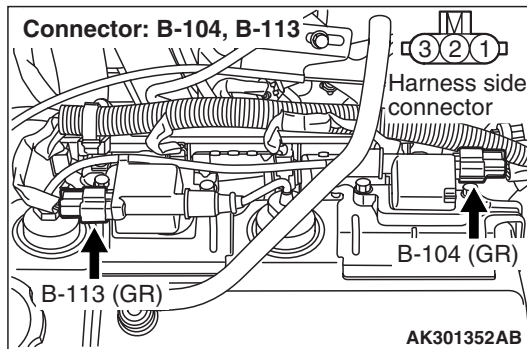
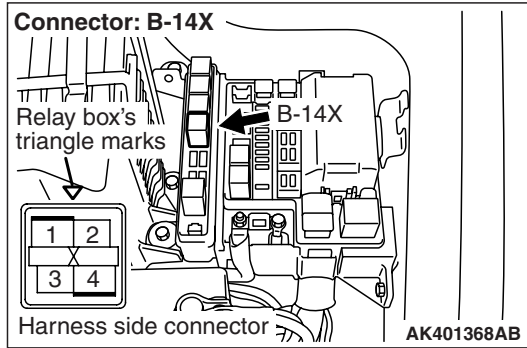

- Check power supply line for damage.

Q: Is the check result normal?

YES : Go to Step 22 .
NO : Repair.

STEP 22. Check harness between B-113 (terminal No. 3) ignition coil connector and C-123 (terminal No. 23) engine-ECU <M/T> connector or C-122 (terminal No. 12) engine-A/T-ECU <A/T> connector, also between B-104 (terminal No. 3) ignition coil connector and C-123 (terminal No. 10) engine-ECU <M/T> connector or C-122 (terminal No. 11) engine-A/T-ECU <A/T> connector.

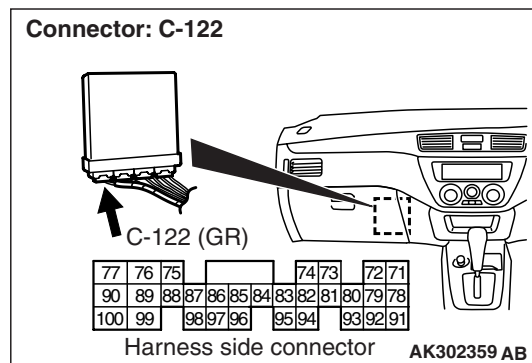
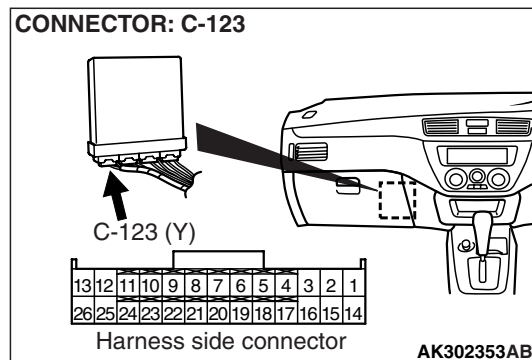
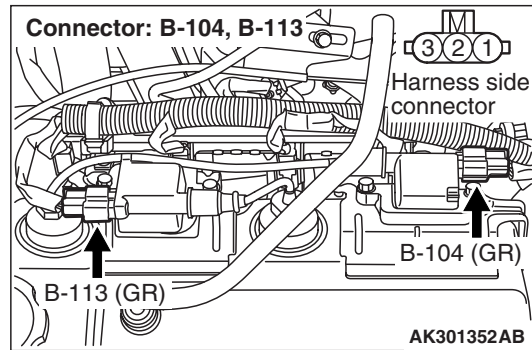

- Check output line for damage.

Q: Is the check result normal?

YES : Go to Step 17 .
NO : Repair.

Data List Reference Table

M1131152002151

Item No.	Inspection item	Inspection condition		Normal condition	Inspection procedure No.	Reference page
11	Oxygen sensor (front)	Engine: After warm-up (leaner by deceleration, richer by acceleration)	Excessive deceleration from 4,000 r/min	200 mV or less → 600 – 1,000 mV (After several seconds have elapsed)	Code No. P0130	P.13A-74
			At excessive acceleration	600 – 1,000 mV		
		Engine: After warm-up (using oxygen sensor, check air-fuel ratio as well as control status by engine-ECU <M/T> or engine-A/T-ECU <A/T>.	Idle operation 2,500 r/min	400 mV or less ⇔ 600 – 1,000 mV (altered)		
13	Intake air temperature sensor	Ignition switch: "ON" or engine running	Intake air temperature: -20° C	-20° C	Code No. P0110	P.13A-33
			Intake air temperature: 0° C	0° C		
			Intake air temperature: 20° C	20° C		
			Intake air temperature: 40° C	40° C		
			Intake air temperature: 80° C	80° C		
14	Throttle position sensor	Ignition switch: "ON"	Set to Idle position	335 – 935 mV	Code No. P0120	P.13A-54
			Press down accelerator pedal gradually	Increased according to accelerator pedal stroke		
			Press down accelerator pedal fully	4,500 – 5,000 mV		
16	Power supply voltage	Ignition switch: "ON"		System voltage	Procedure No. 23	P.13A-321
18	Cranking signal (ignition switch-ST)	Ignition switch: "ON"	Engine: Stopped	OFF	Procedure No. 23	P.13A-321
			Engine: Cranking	ON		

Item No.	Inspection item	Inspection condition	Normal condition	Inspection procedure No.	Reference page		
21	Engine coolant temperature sensor	Ignition switch: "ON" or engine running	Coolant temperature: -20° C	-20° C	Code No. P0115	P.13A-43	
			Coolant temperature: 0° C	0° C			
			Coolant temperature: 20° C	20° C			
			Coolant temperature: 40° C	40° C			
			Coolant temperature: 80° C	80° C			
22	Crank angle sensor	<ul style="list-style-type: none"> • Engine: Cranking • Tachometer: Connected 	Compare engine speed on tachometer with the value displayed on M.U.T.-II/III	Matched	Code No. P0335	P.13A-161	
			Engine: Idle operation	Coolant temperature: -20° C			1,330 – 1,530 r/min
		Coolant temperature: 0° C		1,210 – 1,410 r/min			
		Coolant temperature: 20° C		1,100 – 1,300 r/min			
		Coolant temperature: 40° C		950 – 1,150 r/min			
		Coolant temperature: 80° C	650 – 850 r/min				
27	Power steering fluid pressure switch	Engine: Idle operation	Steering wheel: Stationary	OFF	Code No. P0551	P.13A-216	
			Steering wheel: Turning	ON			
28	A/C switch	Engine: Idle operation	AC switch: OFF	OFF	Procedure No. 26	P.13A-352	
			AC switch: ON	A/C compressor is not driven			OFF
				A/C compressor is driven			ON

Item No.	Inspection item	Inspection condition	Normal condition	Inspection procedure No.	Reference page	
32	Manifold absolute pressure sensor	Ignition switch: "ON"	Altitude: 0m	101kPa	Code No.P0105	P.13A-18
			Altitude: 600m	95kPa		
			Altitude: 1,200m	88kPa		
			Altitude: 1,800m	81kPa		
		<ul style="list-style-type: none"> • Engine coolant temperature: 85 – 95° C • Lamps, electric cooling fan and all accessories: OFF • Transmission : Neutral <M/T> or P range <A/T> 	Idle operation	21.3 – 34.7 kPa		
			Excessive acceleration	Increased		
37	Volumetric efficiency	<ul style="list-style-type: none"> • Engine coolant temperature: 85 – 95° C • Lamps, electric cooling fan and all accessories: OFF 	Idle operation	15 – 35%	–	–
			2,500 r/min	15 – 35%		
			Excessive acceleration	According to acceleration, volumetric efficiency is increased.		
41	Injector drive time *1	Engine: Cranking	Coolant temperature: 0° C (all cylinders in simultaneous injecting operation)	40 – 60 ms	–	–
			Coolant temperature: 20° C	22.4 – 33.6 ms		
			Coolant temperature: 80° C	6.4 – 9.6 ms		
	Injector drive time *2	<ul style="list-style-type: none"> • Engine coolant temperature: 85 – 95° C • Lamps, electric cooling fan and all accessories: OFF • Transmission : Neutral <M/T> or P range <A/T> 	Idle operation	1.7 – 2.9 ms		
			2,500 r/min	1.7 – 2.9 ms		
			Excessive acceleration	Increased		

Item No.	Inspection item	Inspection condition	Normal condition	Inspection procedure No.	Reference page		
44	Ignition advance	<ul style="list-style-type: none"> • Engine: After warm-up • Install timing light (for use to measure actual ignition timing) 	Idle operation	2 – 18° BTDC	Procedure No. 28 <L. H. drive vehicles> Procedure No. 29 <R. H. drive vehicles>	P.13A-361 <L. H. drive vehicles>, P.13A-368 <R. H. drive vehicles>	
			2,500 r/m	-2 – 18° BTDC			
45	ISC (stepper motor) servo position *3	<ul style="list-style-type: none"> • Engine coolant temperature: 80 – 95° C • Lighting, electric cooling fan and accessories: OFF • Transmission : Neutral <M/T> or P range <A/T> • Engine: Idle operation (When A/C switch is ON, A/C compressor must be ON) 	A/C switch: OFF	2 –25 steps	-	-	
			A/C switch: OFF → ON	Increased 10 – 70 steps			
49	A/C relay	Engine: Idle operation after warm-up	A/C switch: OFF	OFF	Procedure No. 26	P.13A-352	
			A/C switch: ON	A/C compressor is not driven			OFF
				A/C compressor is driven			ON
59	Oxygen sensor (rear)	Engine: After warm-up	At excessive acceleration	0 mV or less ⇔ 600 - 1,000 mV (altered)	Code No. P0136	P.13A-91	
13*4	Intake air temperature sensor	Ignition switch: "ON" or engine running	Intake air temperature: -20° C	-20° C	Code No. P0110	P.13A-33	
			Intake air temperature: 0° C	0° C			
			Intake air temperature: 20° C	20° C			
			Intake air temperature: 40° C	40° C			
			Intake air temperature: 80° C	80° C			

Item No.	Inspection item	Inspection condition	Normal condition	Inspection procedure No.	Reference page	
21 ^{*4}	Engine coolant temperature sensor	Ignition switch: "ON" or engine running	Coolant temperature: -20° C	-20° C	Code No. P0115	P.13A-43
			Coolant temperature: 0° C	0° C		
			Coolant temperature: 20° C	20° C		
			Coolant temperature: 40° C	40° C		
			Coolant temperature: 80° C	80° C		
22 ^{*4}	Crank angle sensor	<ul style="list-style-type: none"> Engine: Cranking Tachometer: Connected 	Compare engine speed on tachometer with the value displayed on M.U.T.-II/III	Matched	-	-
			Engine: Idle operation	Coolant temperature: -20° C		
		Coolant temperature: 0° C		1,210 – 1,410 r/min		
		Coolant temperature: 20° C		1,100 – 1,300 r/min		
		Coolant temperature: 40° C		950 – 1,150 r/min		
Coolant temperature: 80° C	650 – 850 r/min					
24 ^{*4}	Vehicle speed sensor	Drive 40 km/h	Approximately 40 km/h	Code No. P0500	P.13A-203	
32 ^{*4}	Manifold absolute pressure sensor	Ignition switch: "ON"	Altitude: 0m	101kPa	Code No. P0105	P.13A-18
			Altitude: 600m	95kPa		
			Altitude: 1,200m	88kPa		
			Altitude: 1,800m	81kPa		
		<ul style="list-style-type: none"> Engine coolant temperature: 85 - 95° C Lamps, electric cooling fan and all accessories: OFF Transmission : Neutral<M/T> or P range<A/T> 	Idle operation	21.3 – 34.7 kPa		
			Excessive acceleration	Increased		

Item No.	Inspection item	Inspection condition		Normal condition	Inspection procedure No.	Reference page
44*4	Ignition advance	<ul style="list-style-type: none"> Engine: After warm-up Install timing light (for use to measure actual ignition timing) 	Idle operation	2 – 18 deg	–	–
			2,500 r/m	–2 – 18 deg		
81*4	Long-term fuel compensation	Engine: After warm-up, 2,500 r/min without any load (during closed loop)		–12.5 – 12.5%	Code No. P0170	P.13A-110
82*4	Short-term fuel compensation	Engine: After warm-up, 2,500 r/min without any load (during closed loop)		–20 – 20%	Code No. P0170	P.13A-110
87*4	Calculation load value	Engine: After warm-up	Idle operation	15 – 35%	–	–
			2,500 r/m	15 – 35%		
88*4	Fuel control condition	Engine: After warm-up	2,500 r/m	Closed loop	–	–
			Acceleration	Open loop-drive condition		
8A*4	Throttle position sensor (Throttle opening angle)	Ignition switch: "ON"	Set to Idle position	0 – 10%	Code No. P0120	P.13A-54
			Press down accelerator pedal gradually	Increased according to accelerator pedal stroke		
			Press down accelerator pedal fully	80 – 100%		
A1*4	Oxygen sensor (front)	Engine: After warm-up (leaner by deceleration, richer by acceleration)	Excessive deceleration from 4,000 r/min	0.2 V or less → 0.6 – 1 V (After several seconds have elapsed)	Code No. P0130	P.13A-74
			Ax excessive acceleration	600 – 1,000 mV		
		Engine: After warm-up (using oxygen sensor, check air-fuel ratio as well as control status by engine-A/ECU.	Idle operation	0.4 V or less ⇔		
			2,500 r/min	0.6 – 1 V (altered)		
A2*4	Oxygen sensor (rear)	Engine: After warm-up	At excessive acceleration	0 V or less ⇔ 0.6 – 1 V (altered)	Code No. P0136	P.13A-91

⚠ CAUTION

When shifting the select lever to D range, the brakes should be applied so that the vehicle does not move forward

*NOTE: *1: Injector drive time ranges shown are when power voltage is 11 V and the cranking speed is 250 r/min. or less.*

*NOTE: *2: On the new vehicle (mileage: 500 km or less), injector drive time may be longer by approximately 10%.*

*NOTE: *3: On the new vehicle (mileage: 500 km or less), the number of steps of stepper motor may be larger by approximately 30 steps.*

*NOTE: *4: When service data in check mode is selected, the data is not displayed.*

Actuator Test Reference Table

M1131152500503

Item No.	Inspection item	Drive content	Inspection conditions		Normal condition	Code No. /Inspection procedure No.	Reference page
01	Injector	Cut off No. 1 injector	Engine: After warm-up, idle operation (Cut off injectors sequentially to check for a cylinder that does not change engine in idle status.		Engine is changed (becomes unstable or stalled)	Code No. P0201	P.13A-115
02		Cut off No. 2 injector				Code No. P0202	P.13A-121
03		Cut off No. 3 injector				Code No. P0203	P.13A-127
04		Cut off No. 4 injector				Code No. P0204	P.13A-133
07	Fuel pump	Drive fuel pump to circulate fuel	Ignition switch: "ON"	Hold return hose with fingers to feel pulse of fuel flowing	Pulse is felt	Procedure No. 24	P.13A-334
				Check for pump operating noise near fuel tank	Operating noise audible		
08	Purge control solenoid valve	Switch solenoid valve from OFF to ON	Ignition switch: "ON"		When the valve is actuated, operating noise is audible	Code No. P0443	P.13A-195
10	EGR control solenoid valve	Switch solenoid valve from OFF to ON	Ignition switch: "ON"		When the valve is actuated, operating noise is audible.	Code No. P0403	P.13A-188
17	Basic ignition timing	Switch engine-ECU <M/T> or engine-A/T-ECU <A/T> to ignition timing adjusting mode	<ul style="list-style-type: none"> • Engine: Idle operation • Install timing light 		5° BTDC	—	—
21	Fan controller	Actuate fan motor	<ul style="list-style-type: none"> • Ignition switch: "ON" • A/C switch: ON 		Fan motor is rotated	Procedure No. 21	P.13A-316

CHECK AT THE ECU TERMINALS

M1131153500205

TERMINAL VOLTAGE CHECK CHART

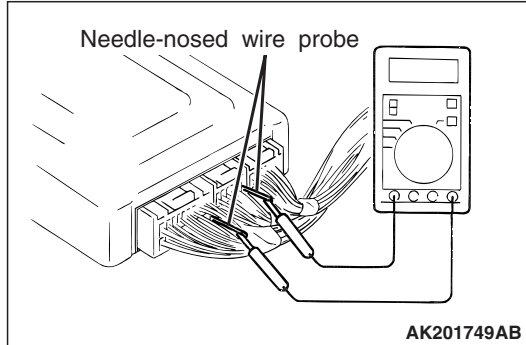

1. Connect a needle-nosed wire probe to a voltmeter probe.
2. Insert the needle-nosed wire probe into each of the engine-ECU <M/T> or engine-A/T-ECU <A/T> connector terminals from the wire side, and measure the voltage while referring to the check chart.

NOTE:

1. Make the voltage measurement with the engine-ECU <M/T> or engine-A/T-ECU <A/T> connector connected.
2. You may find it convenient to pull out the engine-ECU <M/T> or engine-A/T-ECU <A/T> to make it easier to reach the connector terminals.
3. The checks can be carried out off the order given in the chart.

⚠ CAUTION

Short-circuiting the positive (+) probe between a connector terminal and earth could damage the vehicle wiring, the sensor, engine-ECU <M/T> or engine-A/T-ECU <A/T> or all of them. Be careful to prevent this!

3. If voltmeter shows any deviation from standard value, check the corresponding sensor, actuator and related electrical wiring, then repair or replace.
4. After repair or replacement, recheck with the voltmeter to confirm that the repair has corrected the problem.

Engine-ECU <M/T> or Engine-A/T-ECU <A/T> Connector Terminal Arrangement

Engine-ECU Connector

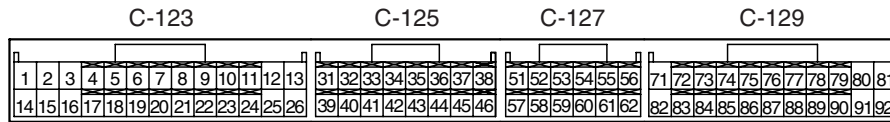

AK301374AB

Engine-A/T-ECU Connector

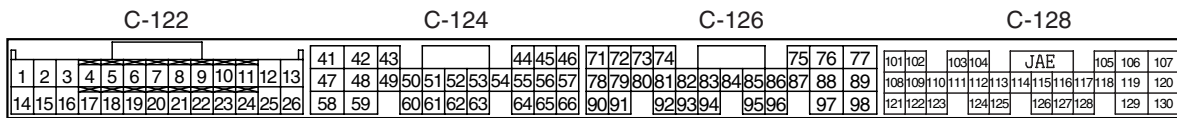

AK301375AB

Terminal No. <M/T>	Terminal No. <A/T>	Check item	Check condition (Engine condition)	Normal condition
1	1	No. 1 injector	While engine is idling after having warmed up, suddenly depress the accelerator pedal.	From 11 – 14 V, momentarily drops slightly
14	9	No. 2 injector		
2	24	No. 3 injector		
15	2	No. 4 injector		
4	14	Stepper motor coil <A1>	<ul style="list-style-type: none"> Engine: Soon after the warmed up engine is started A/C switch: OFF → ON (A/C compressor is operating) 	System voltage ↔ 1 V or less (Changes repeatedly)
17	28	Stepper motor coil <A2>		
5	15	Stepper motor coil <B1>		
18	29	Stepper motor coil <B2>		
6	6	EGR control solenoid Valve	Ignition switch: "ON"	System Voltage
			While engine is idling, suddenly depress the accelerator pedal.	From system voltage, momentarily drops
8	20	A/C relay	<ul style="list-style-type: none"> Engine: Idle speed A/C switch: OFF → ON (A/C compressor is operating) 	System voltage or Momentarily 6 V or more → 1 V or less
9	34	Purge control solenoid valve	Ignition switch: "ON"	System voltage
			Running at 3,500 r/min while engine is warming up after having been started.	1 V or less
10	11	Ignition coil – No. 1, No. 4	Engine r/min: 3,000 r/min	0.3 – 3.0 V
23	12	Ignition coil – No. 2, No. 3		
12	41	Power supply	Ignition switch: "ON"	System voltage
25	47			

Terminal No. <M/T>	Terminal No. <A/T>	Check item	Check condition (Engine condition)	Normal condition	
21	18	Fan controller	Radiator and condenser fan is not operating	0 – 0.3 V	
			Radiator and condenser fan is operating	0.7 V or more	
22	21	Fuel pump relay	Ignition switch: ON	System voltage	
			Engine: Idle speed	1 V or less	
24	61	A/C load signal	Refer to GROUP 55 - Troubleshooting (Inspection at the Automatic compressor - ECU Terminal)		
33	8	Alternator G terminal	<ul style="list-style-type: none"> • Engine: Warm, idle (radiator fan: OFF) • Headlamp: OFF → ON • Stop lamp: OFF → ON • Rear defogger switch: OFF → ON 	Voltage increases by 0.2 – 3.5 V	
36	22	Engine warming lamp	Ignition switch: "LOCK" (OFF) → "ON"	1 V or less → System voltage (After several seconds have elapsed)	
37	52	Power steering fluid pressure switch	Engine: Idling after warming up	When steering wheel is stationary	System voltage
				When steering wheel is turned	1 V or less
38	49	Control relay (Power supply)	Ignition switch: "LOCK" (OFF)	System voltage	
			Ignition switch: "ON"	1 V or less	
41	54	Alternator FR terminal	<ul style="list-style-type: none"> • Engine: Warm, idle (radiator fan: OFF) • Headlamp: OFF → ON • Stop lamp: OFF → ON • Rear defogger switch: OFF → ON 	Voltage decreases	
45	83	A/C switch	Engine: Idle speed	Turn the A/C switch OFF	0.5 V or less
				Turn the A/C switch ON (A/C compressor is operating)	System voltage
54	26	Oxygen sensor heater (rear)	Engine: Idling after warming up	1 V or less	
			Engine: Racing	System voltage	
58	43	Tachometer signal	Engine: 3,000 r/min	0.3 – 3.0 V	
60	3	Oxygen sensor heater (front)	Engine: Idling after warming up	1 V or less	
			Engine: 5,000 r/min	System voltage	
71	58	Ignition switch-ST	Engine: Cranking	8 V or more	

Terminal No. <M/T>	Terminal No. <A/T>	Check item	Check condition (Engine condition)	Normal condition	
72	64	Intake air temperature sensor	Ignition switch: "ON"	When intake air temperature is -20° C	3.8 – 4.4 V
				When intake air temperature is 0° C	3.2 – 3.8 V
				When intake air temperature is 20° C	2.3 – 2.9 V
				When intake air temperature is 40° C	1.5 – 2.1 V
				When intake air temperature is 60° C	0.8 – 1.4 V
				When intake air temperature is 80° C	0.4 – 1.0 V
75	73	Oxygen sensor (rear)	Engine: Idling after warmed up (Check using a digital type voltmeter)	0 ⇔ 0.6 V (Changes repeatedly)	
76	71	Oxygen sensor (front)	Engine: Running at 2,500 r/min after warmed up (Check using a digital type voltmeter)	0 ⇔ 0.8 V (Changes repeatedly)	
80	66	Backup power supply	Ignition switch: "LOCK" (OFF)	System voltage	
81	46	Sensor impressed voltage	Ignition switch: "ON"	4.9 – 5.1 V	
82	98	Ignition switch-IG	Ignition switch: "ON"	System voltage	

Terminal No. <M/T>	Terminal No. <A/T>	Check item	Check condition (Engine condition)	Normal condition	
83	44	Engine coolant temperature sensor	Ignition switch: "ON"	When engine coolant temperature is -20° C	3.9 – 4.5 V
				When engine coolant temperature is 0° C	3.2 – 3.8 V
				When engine coolant temperature is 20° C	2.3 – 2.9 V
				When engine coolant temperature is 40° C	1.3 – 1.9 V
				When engine coolant temperature is 60° C	0.7 – 1.3 V
				When engine coolant temperature is 80° C	0.3 – 0.9 V
84	78	Throttle position sensor	Ignition switch: "ON"	Set throttle valve to idle Position	0.335 – 0.935 V
				Fully open throttle valve	4.5 – 5.0 V
85	55	Manifold absolute pressure sensor	Ignition switch: "ON"	Altitude: 0 m	3.8 – 4.2 V
				Altitude: 600 m	3.5 – 3.9 V
				Altitude: 1200 m	3.3 – 3.7 V
				Altitude: 1800 m	3.0 – 3.4 V
			Engine: Idling after warming up	0.9 – 1.5 V	
		While engine is idling after having warmed up, suddenly depress the accelerator pedal.	From 0.9 – 1.5 V, momentarily increases		
86	–	Vehicle speed sensor	<ul style="list-style-type: none"> Ignition switch: "ON" Move the vehicle forward slowly 	0 ⇔ 5 V Changes repeatedly	
88	56	Camshaft position sensor	Engine: Cranking	0.4 – 3.0 V	
			Engine: Idling	1.5 – 3.0 V	
89	45	Crank angle sensor	Engine: Cranking	0.4 – 4.0 V	
			Engine: Idling speed	1.5 – 2.5 V	

CHECK CHART FOR RESISTANCE AND CONTINUITY BETWEEN TERMINALS

1. Turn the ignition switch to "LOCK" (OFF) position.
2. Disconnect the engine-ECU <M/T> or engine-A/T-ECU <A/T> connector.
3. Measure the resistance and check for continuity between the terminals of the engine-ECU <M/T> or engine-A/T-ECU <A/T> harness-side connector while referring to the check chart.

NOTE:

1. *When measuring resistance and checking continuity, a harness for checking contact pin pressure should be used instead of inserting a test probe.*
2. *Checking need not be carried out in the order given in the chart.*

CAUTION

If the terminals that should be checked are mistaken, or if connector terminals are not correctly shorted to earth, damage may be caused to the vehicle wiring, sensors, engine-ECU <M/T> or engine-A/T-ECU <A/T> and/or ohmmeter. Be careful to prevent this!

4. If the ohmmeter shows any deviation from the standard value, check the corresponding sensor, actuator and related electrical wiring, and the repair or replace.
5. After repair or replacement, recheck with the ohmmeter to confirm that the repair or replacement has corrected the problem.

Engine-ECU <M/T> or Engine-A/T-ECU <A/T> Harness Side Connector Terminal Arrangement

Engine-ECU Harness side connector

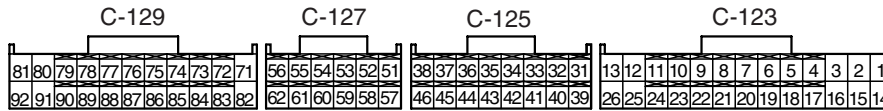

AK301376AB

Engine-A/T-ECU Harness side connector terminal arrangement

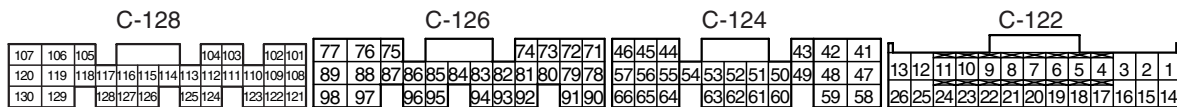

AK301377AB

Terminal No. <M/T>	Terminal No. <A/T>	Inspection item	Normal condition (Check condition)
1 – 12	1 – 42	No. 1 injector	13 – 16 Ω (At 20° C)
12 – 14	9 – 42	No. 2 injector	
2 – 12	24 – 42	No. 3 injector	
12 – 15	2 – 42	No. 4 injector	
4 – 12	14 – 42	Stepper motor coil (A1)	28 – 33 Ω (At 20° C)
12 – 17	28 – 42	Stepper motor coil (A2)	
5 – 12	15 – 42	Stepper motor coil (B1)	
12 – 18	29 – 42	Stepper motor coil (B2)	
6 – 12	4 – 42	EGR control solenoid valve	29 – 35 Ω (At 20° C)
9 – 12	34 – 42	Purge control solenoid valve	30 – 34 Ω (At 20° C)
12 – 54	26 – 42	Oxygen sensor heater (rear)	4.5 – 8.0 Ω (At 20° C)
12 – 60	3 – 42	Oxygen sensor heater (front)	4.5 – 8.0 Ω (At 20° C)
13 – Body earth	42 – Body earth	ECU earth	Continuity (0 Ω)
26 – Body earth	76 – Body earth		
81 – 83	44 – 57	Engine coolant temperature sensor	14 – 17 kΩ (When coolant temperature is – 20° C)
			5.1 – 6.5 kΩ (When coolant temperature is 0° C)
			2.1 – 2.7 kΩ (When coolant temperature is 20° C)
			0.9 – 1.3 kΩ (When coolant temperature is 40° C)
			0.48 – 0.68 kΩ (When coolant temperature is 60° C)
			0.26 – 0.36 kΩ (When coolant temperature is 80° C)

Terminal No. <M/T>	Terminal No. <A/T>	Inspection item	Normal condition (Check condition)
72 – 81	57 – 64	Intake air temperature sensor	13 – 17 kΩ (When intake air temperature is – 20° C)
			5.3 – 6.7 kΩ (When intake air temperature is 0° C)
			2.3 – 3.0 kΩ (When intake air temperature is 20° C)
			1.0 – 1.5 kΩ (When intake air temperature is 40° C)
			0.56 – 0.76 kΩ (When intake air temperature is 60° C)
			0.30 – 0.42 kΩ (When intake air temperature is 80° C)

INSPECTION PROCEDURE USING OSCILLOSCOPE

M1131154500606

The output signals of the sensors and the conditions of the actuation signals of the actuators can be inspected visually by observing the waveforms on the oscilloscope.

CAMSHAFT POSITION SENSOR AND CRANK ANGLE SENSOR

Measurement Method

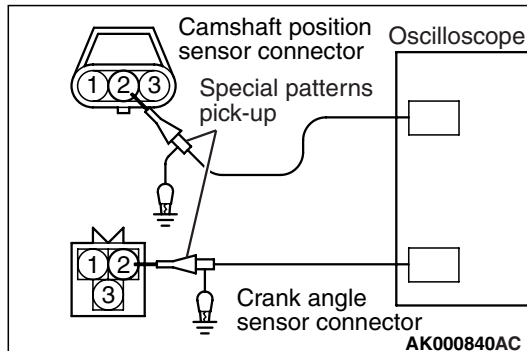

1. Disconnect the camshaft position sensor connector and connect the special tool test harness (MB991709) in between (All terminals should be connected).
2. Connect the oscilloscope special pattern pickup to camshaft position sensor terminal No. 2.

3. Disconnect the crank angle sensor connector and connect the special tool test harness (MD998478) in between.
4. Connect the oscilloscope special patterns pickup to crank angle sensor terminal No. 2.

Alternate Method (Test harness not available)

1. Connect the oscilloscope special patterns pickup to engine-ECU terminal No. 88 <M/T> or engine-A/T-ECU terminal No. 56 <A/T> (When checking the camshaft position sensor signal wave pattern).
2. Connect the oscilloscope special patterns pickup to engine-ECU terminal No. 89 <M/T> or engine-A/T-ECU terminal No. 45 <A/T> (When checking the crank angle sensor signal wave pattern).

Standard Wave Pattern

Observation condition

Function	Special patterns
Pattern height	Low
Pattern selector	Display
Engine speed	Idle

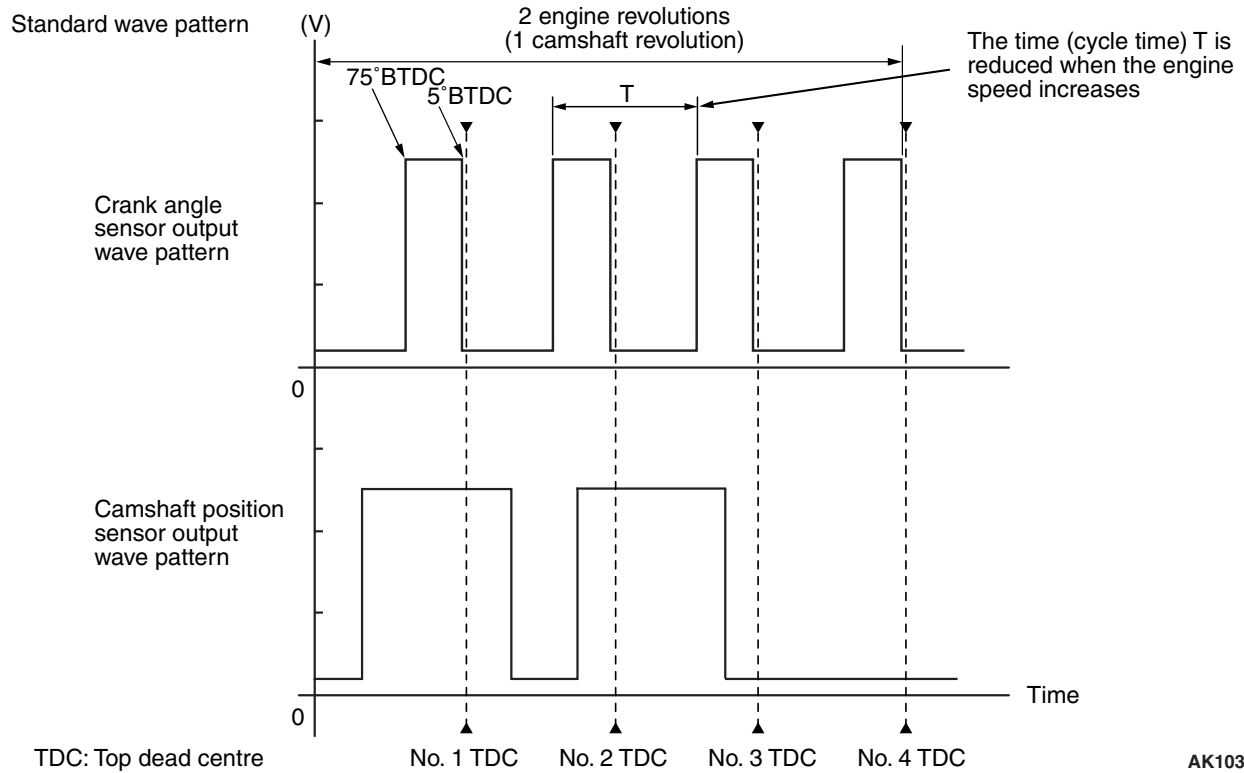

Wave Pattern Observation Points

Check that cycle time T becomes shorter when the engine speed increases.

Wave pattern characteristics

Rectangular wave pattern is output even when the engine is not started.

Examples of Abnormal Wave Patterns

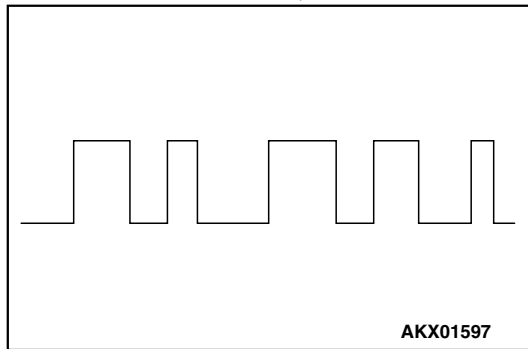

Example 1

Cause of problem

Sensor interface malfunction

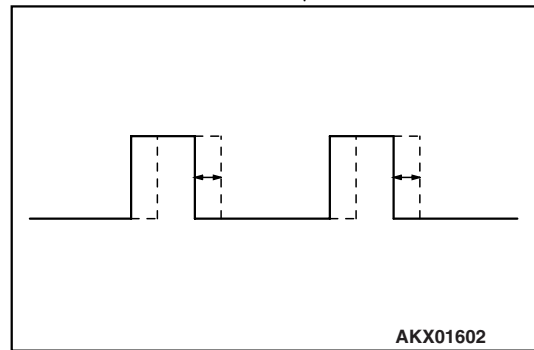

Example 2

Cause of problem

Loose timing belt
Abnormality in sensor disk

Wave pattern characteristics

Wave pattern is displaced to the left or right.

INJECTOR

Measurement Method

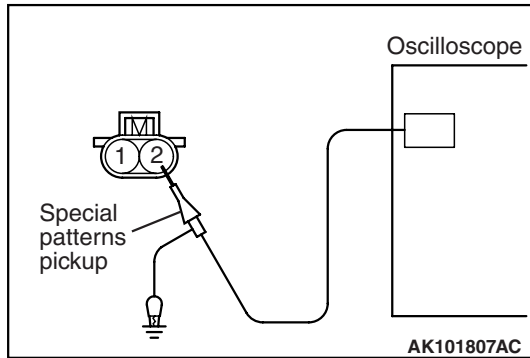

1. Disconnect the injector connector, and then connect the special tool test harness set (MB991348) in between (All terminals should be connected).
2. Connect the oscilloscope special patterns pickup to terminal No. 2 of the injector connector.

Alternate Method (Test harness not available)

1. Connect the oscilloscope special patterns pickup to engine- ECU terminal No. 1 <M/T> or engine-A/T-ECU terminal No. 1 <A/T> (When checking the No. 1 cylinder).

2. Connect the oscilloscope special patterns pickup to engine-ECU terminal No. 14 <M/T> or engine-A/T-ECU terminal No. 9 <A/T> (When checking the No. 2 cylinder).
3. Connect the oscilloscope special patterns pickup to engine-ECU terminal No. 2 <M/T> or engine-A/T-ECU terminal No. 24 <A/T> (When checking the No. 3 cylinder).
4. Connect the oscilloscope special patterns pickup to engine-ECU terminal No. 15 <M/T> or engine-A/T-ECU terminal No. 2 <A/T> (When checking the No. 4 cylinder).

Standard Wave Pattern

Observation conditions

Function	Special patterns
Pattern height	Variable
Variable knob	Adjust while viewing the wave pattern
Pattern selector	Display
Engine speed	Idle

Standard wave pattern

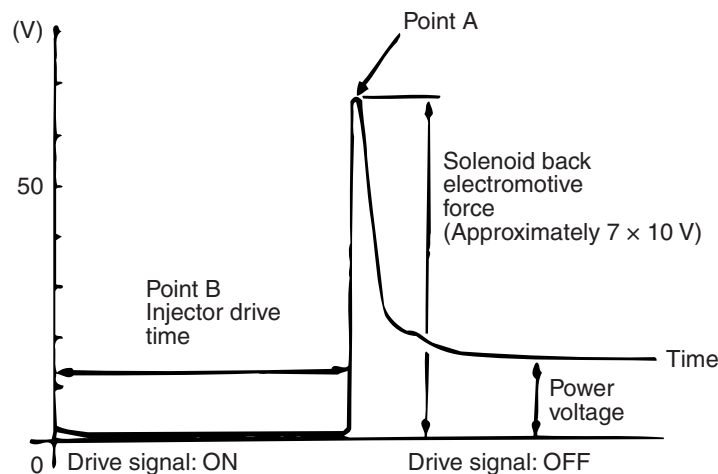

Wave Pattern Observation Points

Point A: Height of solenoid back electromotive force

Contrast with standard wave pattern	Probable cause
Solenoid coil back electromotive force is low or doesn't appear at all.	Short in the injector solenoid

Point B: Injector drive time

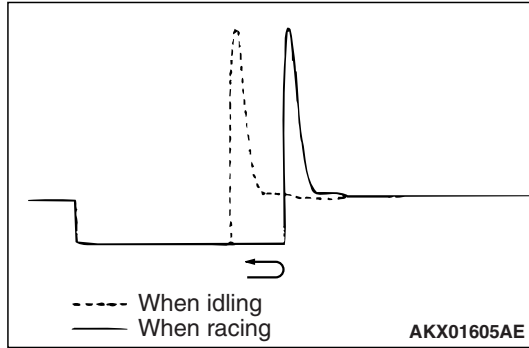

The injector drive time will be synchronized with the M.U.T.-II/III tester display.

- When the engine is suddenly raced, the drive time will be greatly extended at first, but the drive time will soon match the engine speed.

IDLE SPEED CONTROL (ISC) SERVO (STEPPER MOTOR)

Measurement Method

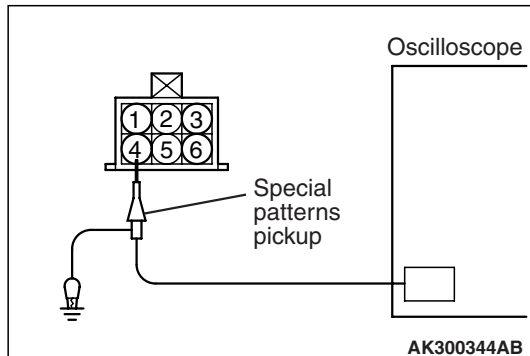

1. Disconnect the ISC servo connector, and connect the special tool test harness (MB991709) in between.

2. Connect the oscilloscope special patterns pickup to the ISC servo- side connector terminal No. 1, No. 3, No. 4 and No. 6 respectively.

Alternate Method (Test harness not available)

1. Connect the oscilloscope special patterns pickup to engine-ECU terminal No. 4 <M/T> or engine-A/T-ECU terminal No. 14 <A/T>, connection terminal No. 5 <M/T> or engine-A/T-ECU terminal No. 15 <A/T>, connection terminal No. 17 <M/T> or engine-A/T-ECU terminal No. 28 <A/T>, and connection terminal No. 18 <M/T> or engine-A/T-ECU terminal No. 29 <A/T> respectively.

Standard Wave Pattern

Observation conditions

Function	Special patterns
Pattern height	High
Pattern selector	Display
Engine condition	When the engine coolant temperature is 20° C or below, turn the ignition switch from LOCK (OFF) position to ON (without starting the engine).
	While the engine is idling, turn the A/C switch to ON.
	Immediately after starting the warm engine.

Standard wave pattern

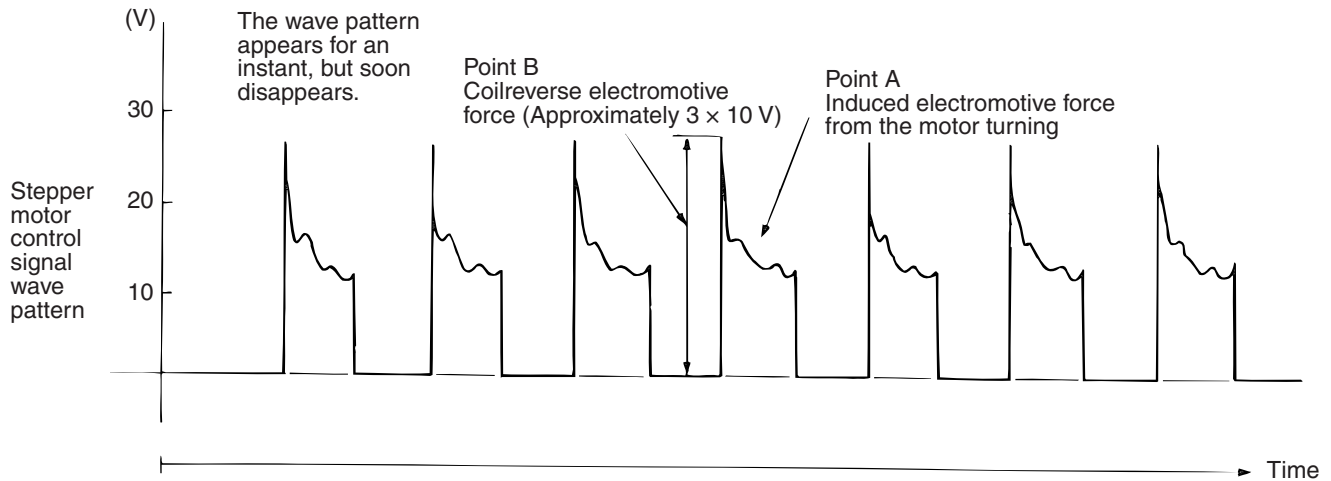

AK201857AC

Wave pattern Observation Points

Check that the standard wave pattern appears when the stepper motor is operating.

Point A: Presence or absence of induced electromotive force from the motor turning (Refer to the abnormal wave pattern).

Contrast with standard wave pattern	Probable cause
Induced electromotive force does not appear or is extremely small.	Motor is malfunctioning

Point B: Height of coil reverse electromotive force

Contrast with standard wave pattern	Probable cause
Coil reverse electromotive force does not appear or is extremely small.	Short in the coil

Examples of Abnormal Wave Pattern

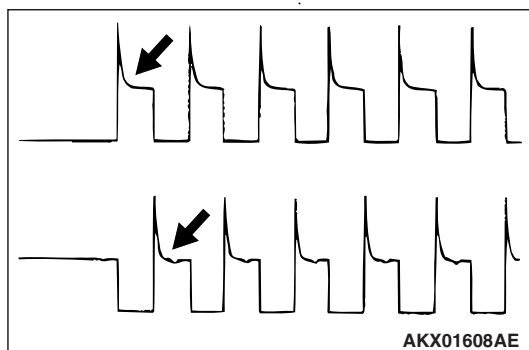

Example 1

Cause of problem

Motor is malfunctioning. (Motor is not operating.)

Wave pattern characteristics

Induced electromotive force from the motor turning does not appear.

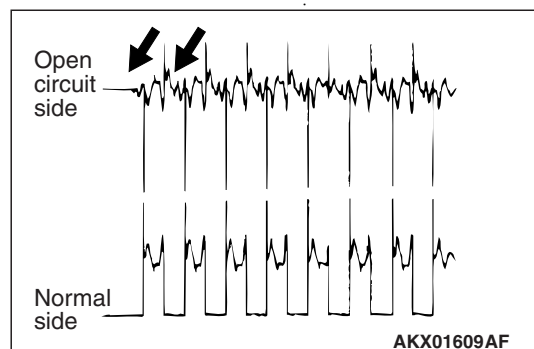

Example 2

Cause of problem

Open circuit in the line between the stepper motor and the engine-ECU <M/T> or engine-A/T-ECU <A/T>.

Wave pattern characteristics

Current is not supplied to the motor coil on the open circuit side (Voltage does not drop to 0 V). Furthermore, the induced electromotive force waveform at the normal side is slightly different from the normal waveform.

IGNITION COIL AND POWER TRANSISTOR

Measurement Method

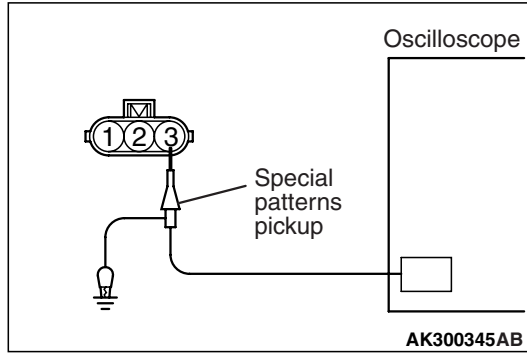

1. Disconnect the ignition coil connector, and connect the special tool test harness set (MB991348) in between (All terminals should be connected).
2. Connect the oscilloscope special patterns pickup to terminal No. 3 of each ignition coil connector in turn.

Alternate Method (Test harness not available)

1. Connect the oscilloscope special patterns pickup to engine-ECU terminal No. 10 (No. 1 – No. 4) <M/T> or engine-A/T-ECU terminal No. 11 (No. 1 – No. 4) <A/T>, connection terminal No. 23 (No. 2 – No. 3) <M/T> or engine-A/T-ECU terminal No. 12 (No. 2 – No. 3) <A/T> respectively.

Standard Wave Pattern

Observation condition

Function	Special patterns
Pattern height	Low
Pattern selector	Display
Engine r/min	Approximately 1,200 r/min

Standard wave pattern

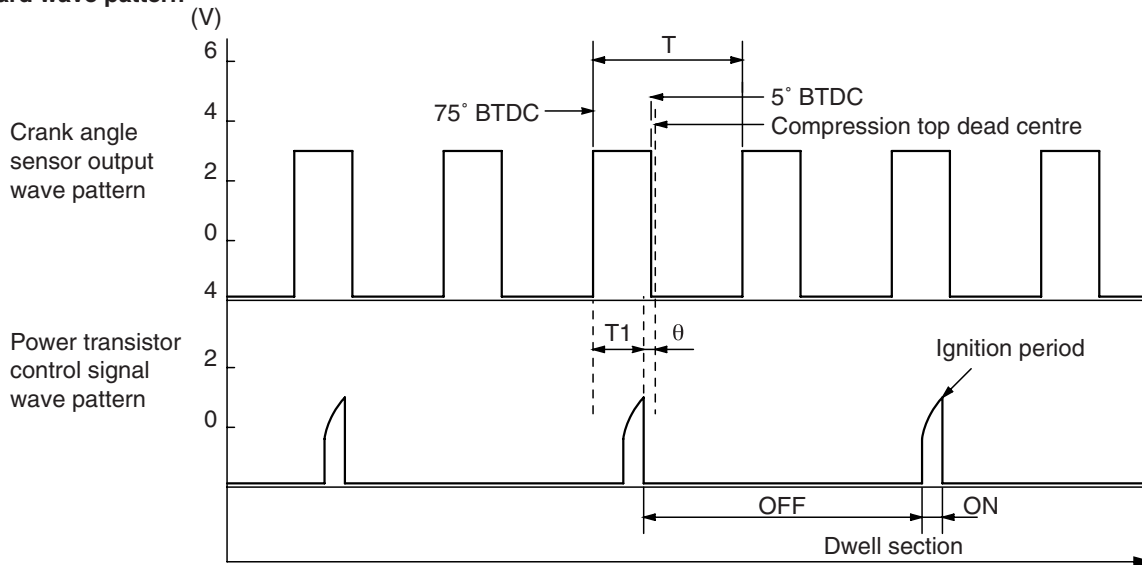

T : Revolution time corresponding to a crank angle of 180°
 T1 : Time computed by the engine-ECU <M/T> or engine-A/T-ECU <A/T>
 θ : Spark advance angle

Wave Pattern Observation Points

Point: Condition of wave pattern build-up section and maximum voltage (Refer to abnormal wave pattern examples 1 and 2).

Condition of wave pattern build-up section and maximum voltage	Probable cause
Rises from approximately 2 V to approximately 4.5 V at the top-right	Normal
2 V rectangular wave	Open-circuit in ignition primary circuit
Rectangular wave at power voltage	Power transistor malfunction

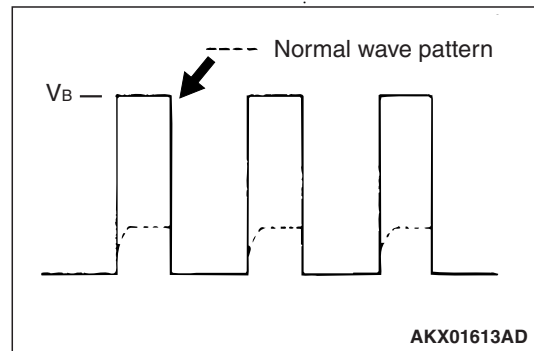

Example 2
Wave pattern during engine cranking

Cause of problem

Malfunction in power transistor

Wave pattern characteristics

Power voltage results when the power transistor is ON.

Examples of Abnormal Wave Patterns

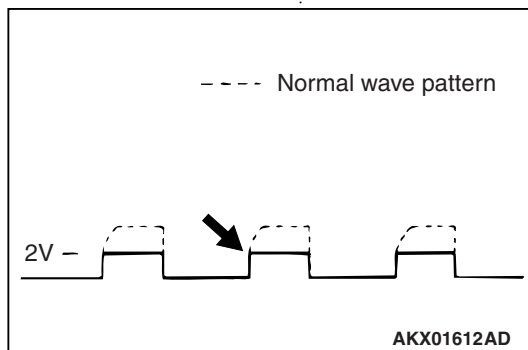

Example 1
Wave pattern during engine cranking

Cause of problem

Open-circuit in ignition primary circuit

Wave pattern characteristics

Top-right part of the build-up section cannot be seen, and voltage value is approximately 2 V too low.

ON-VEHICLE SERVICE

THROTTLE BODY (THROTTLE VALVE AREA) CLEANING

M1131001000451

1. Remove the air intake hose from the throttle body.
2. Spray cleaning fluid on a clean cloth.

CAUTION

- Do not spray the cleaning fluid directly to the throttle valve.
- Make sure the cleaning fluid does not enter the motor from the bypass line. Also make sure it does not enter the sensor through the shaft.
- Be careful not to rub off the molybden applied around the throttle valve shaft.

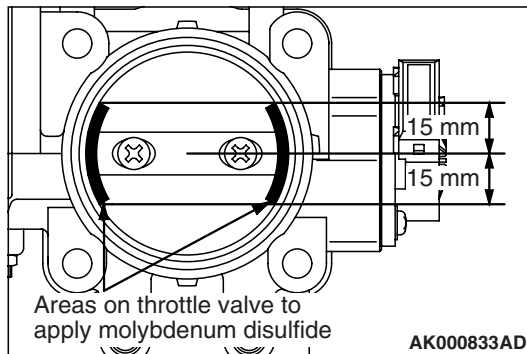

3. Wipe off the dirt around the throttle valve with the cloth sprayed with cleaning fluid.
4. Attach the air intake hose.
5. Adjust the basic idle speed (Refer to P.13A-399).

THROTTLE POSITION SENSOR ADJUSTMENT

M1131001100544

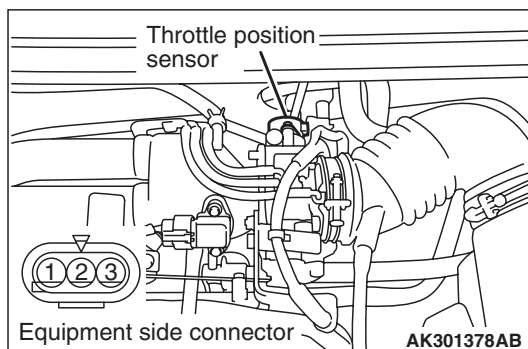

1. Connect the M.U.T.-II/III to the diagnosis connector.

When not using the M.U.T.-II/III, proceed as follows.

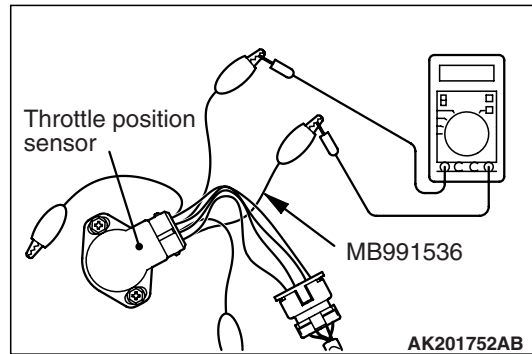

- (1) Disconnect the throttle position sensor connector and connect the special tool test harness (MB991536) between the disconnected connector taking care not to confuse the terminal to be connected.
- (2) Connect digital voltmeter between the terminal No. 2 (special tool's yellow clip on the sensor output) and the terminal No. 4 (special tool's red clip on the sensor earth) of the throttle position sensor connector.
2. Turn the ignition switch to "ON" position (but do not start the engine).
3. Check the output voltage of the throttle position sensor.

Standard value: 335 –935 mV

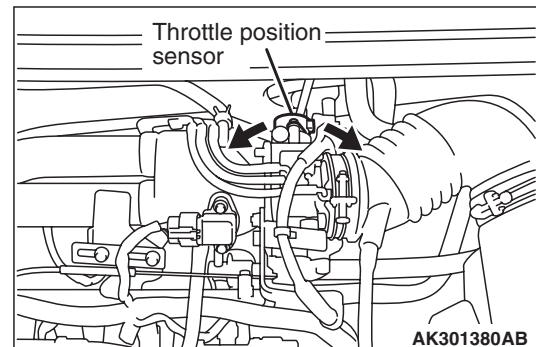

4. If not within the standard value, loosen the throttle position sensor mounting bolts. Then rotate the sensor body to adjust.
5. Turn the ignition switch to "LOCK" (OFF) position.
6. Remove the M.U.T.-II/III. If the M.U.T.-II/III is not used, remove the special tool, and then connect the throttle position sensor connector.
7. If a diagnosis code is displayed, erase the diagnosis code by using the M.U.T.-II/III or disconnect the negative battery cable from the battery terminal and then leave it for at least 10 seconds. After that, reconnect the battery cable, and then let the engine run at idle for approximately 10 minutes.

BASIC IDLE SPEED ADJUSTMENT

M1131001800598

CAUTION

- The standard idling speed has been adjusted by the speed adjusting screw (SAS) by the manufacturer, and there should usually be no need for readjustment.
- If the adjustment has been changed by mistake, the idle speed may become too high or the idle speed may drop too low when loads from components such as the A/C are placed on the engine. If this occurs, adjust by the following procedure.
- The adjustment, if made, should be made after first confirming that the spark plugs, the injectors, the idle speed control servo, the compression pressure, etc., are all normal.

1. Before inspection and adjustment, set the vehicle to the pre-inspection condition.
2. Connect the M.U.T.-II/III to the diagnosis connector (16-pin).

NOTE: When the M.U.T.-II/III is connected, the diagnosis control terminal should be earthed.

3. Start the engine and run at idle.
4. Select the item No. 30 of the M.U.T.-II/III actuator test.

NOTE: This holds the ISC servo at the basic step to adjust the basic idle speed.

5. Check the idle speed.

Standard value: 750 ± 50 r/min

NOTE:

- The engine speed may be 20 to 100 r/min lower than indicated above for a new vehicle [driven approximately 500 km or less], but no adjustment is necessary.
- If the engine stalls or the engine speed is low even though the vehicle has been driven approximately 500 km or more, it is probable that deposits are adhered to the throttle valve, so clean it (Refer to P.13A-398).

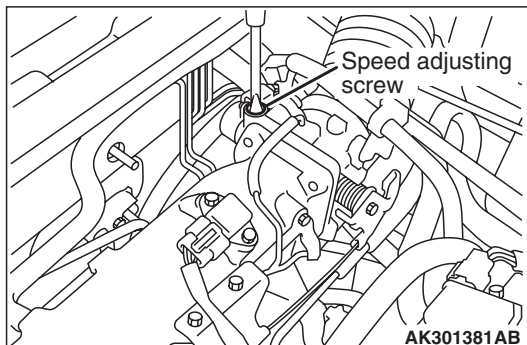

6. If not within the standard value range, turn the speed adjusting screw (SAS) to make the necessary adjustment.

NOTE: If the idling speed is higher than the standard value range even when the SAS is fully closed, check whether or not there is any indication that the fixed SAS has been moved. If there is an indication that it has been moved, adjust the fixed SAS.

7. Press the M.U.T.-II/III clear key, and release the ISC servo from the actuator test mode.

NOTE: Unless the ISC servo is released, the actuator test mode will continue 27 minutes.

8. Turn the ignition switch to "LOCK" (OFF) position.
9. Disconnect the M.U.T.-II/III.
10. Start the engine again and let it run at idle speed for about 10 minutes; check that the idling condition is normal.

FUEL PRESSURE TEST

M1131001900517

1. Release residual pressure from the fuel pipe line to prevent fuel gush out (Refer to P.13A-401).

CAUTION

Cover the hose connection with rags to prevent splash of fuel that could be caused by some residual pressure in the fuel pipe line.

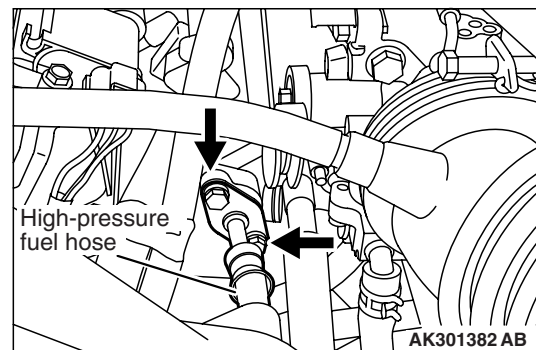

2. Disconnect the high-pressure fuel hose at the delivery pipe side.

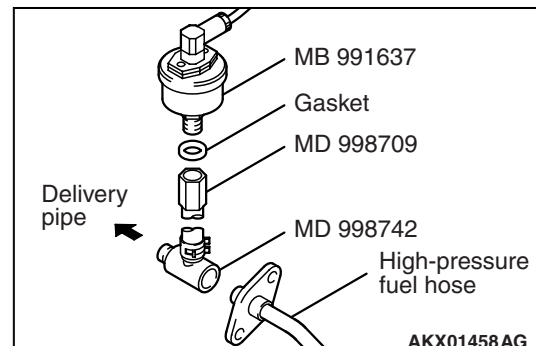

3. Assemble the fuel pressure measurement tools as follows.

<When using the fuel pressure gauge set (special tool)>

- Remove the union joint and bolt from the special tool adaptor hose (MD998709) and attach the special tool hose adaptor (MD998742) to the adaptor hose.
- Via a gasket, install the special tool fuel pressure gauge set (MB991637) into the special tool that has already assembled as described in (a) above.

<When using the fuel pressure gauge>

- Remove the union joint and bolt from special tool adaptor hose (MD998709) and attach the special tool hose adaptor (MD998742) to the adaptor hose.
- Via a suitable O-ring or gasket, install the fuel pressure gauge to the special tool that has already assembled as described in (a) above.

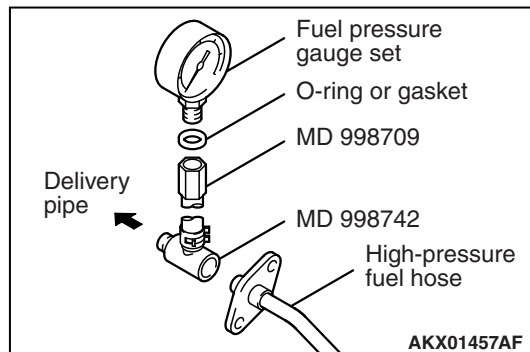

- Install the assembled fuel pressure measurement tools between the fuel rail and high-pressure fuel hose.

CAUTION

To prevent damage to the M.U.T.-II/III, always turn the ignition switch to the "LOCK" (OFF) position before connecting or disconnecting the M.U.T.-II/III.

- Connect the M.U.T.-II/III to the diagnosis connector.

- Turn the ignition switch to "ON" position (But do not start the engine).
- Select "Item No. 07" from the M.U.T.-II/III actuator test to drive the fuel pump. Check that there are no fuel leaks from any parts.
- Finish the actuator test or turn the ignition switch to "LOCK" (OFF) position.
- Start the engine and run at idle.
- Fuel pressure measurement while the engine is running at idle.

Standard value: Approximately 265 kPa at curb idle

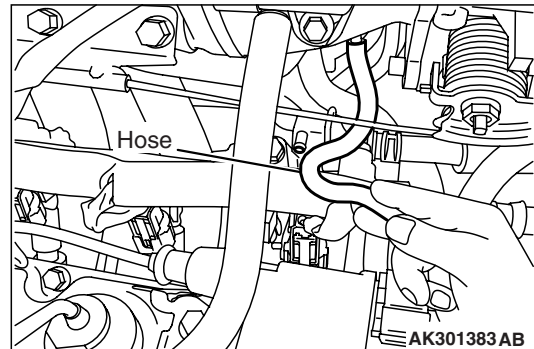

- Disconnect the vacuum hose from the fuel pressure regulator and measure fuel pressure with the hose end closed by a finger.

Standard value: 324 – 343 kPa at curb idle

- Check to see that fuel pressure at idle does not drop even after the engine has been raced several times.
- Racing the engine repeatedly, hold the fuel return hose lightly with fingers to feel that fuel pressure is present in the return hose.

NOTE: If the fuel flow rate is low, there will be no fuel pressure in the return hose.

- If any of fuel pressure measured in steps 10 to 13 is out of specification, troubleshoot and repair according to the table below.

Symptom	Probable cause	Remedy
<ul style="list-style-type: none"> Fuel pressure too low Fuel pressure drops after racing No fuel pressure in fuel return hose 	Clogged fuel filter	Replace fuel filter
	Fuel leaking to return side due to poor fuel regulator valve seating or settled spring	Replace fuel pressure regulator
	Low fuel pump delivery pressure	Replace fuel pump
Fuel pressure too high	Binding valve in fuel pressure regulator	Replace fuel pressure regulator
	Clogged fuel return hose or pipe	Clean or replace hose or pipe
Same fuel pressure when vacuum hose is connected and when disconnected	Damaged vacuum hose or Clogged nipple	Replace vacuum hose or clean nipple

15. Stop the engine and check change of fuel pressure gauge reading. Normal if the reading does not drop within 2 minutes. If it does, observe the rate of drop and troubleshoot and repair according to the table below.

Symptom	Probable cause	Remedy
Fuel pressure drops gradually after engine is stopped	Leaky injector	Replace injector
	Leaky fuel regulator valve seat	Replace fuel pressure regulator
Fuel pressure drops sharply immediately after engine is stopped	Check valve in fuel pump is held open	Replace fuel pump

16. Release residual pressure from the fuel pipe line (Refer to P.13A-401).

CAUTION

Cover the hose connection with rags to prevent splash of fuel that could be caused by some residual pressure in the fuel pipe line.

17. Remove the fuel pressure gauge and special tool from the delivery pipe.

18. Replace the O-ring at the end of the fuel high pressure hose with a new one. Furthermore, apply engine oil to the new O-ring before replacement.

19. Fit the fuel high pressure hose over the delivery pipe and tighten the bolt to specified torque.

Tightening torque: 9.0 ± 2.0 N·m

20. Check for any fuel leaks by following the procedure in step 7.

21. Disconnect the M.U.T.-II/III.

FUEL PUMP CONNECTOR DISCONNECTION (HOW TO REDUCE PRESSURIZED FUEL LINES)

M1131000900570

WARNING

When removing the fuel pipe, etc., release fuel pressure to prevent fuel spray.

1. Remove the rear seat cushion (Refer to GROUP 52A - Rear Seat P.52A-30).
2. Remove the service hole cover mounting screws and remove the service hole cover.

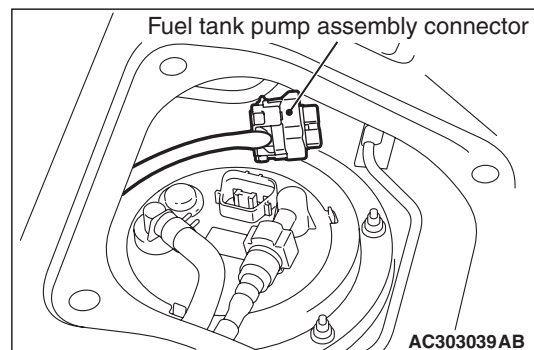

3. Disconnect the fuel tank pump assembly connector.

4. After starting the engine and letting it run until it stops naturally, turn the ignition switch to the "LOCK" (OFF) position.
5. Connect the fuel tank pump assembly connector.
6. Tighten the service hole cover mounting screws and install the service hole cover.
7. Install the rear seat cushion. (Refer to GROUP 52A - Rear Seat P.52A-30).

FUEL PUMP OPERATION CHECK

M1131002000614

1. Check the operating of the fuel tank pump by M.U.T.-II to force-drive the fuel tank pump.
2. If the fuel tank pump will not operate, check by using the following procedure. If normal, check the fuel tank pump drive circuit.
 - (1) Turn the ignition switch to the "LOCK" (OFF) position.
 - (2) Remove the rear seat cushion (Refer to GROUP 52A - Rear Seat P.52A-30).
 - (3) Remove the service hole cover mounting screws and remove the service hole cover.

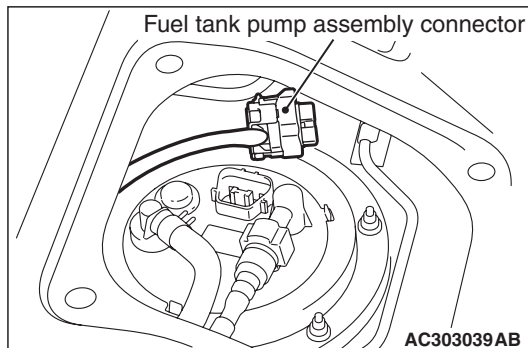

- (4) Disconnect the fuel tank pump assembly connector.

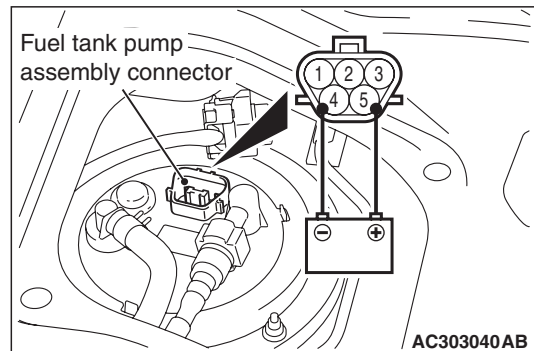

- (5) When the fuel tank pump drive connector is attached directly to the battery, check if the sound of the fuel tank pump operation can be heard. If no operating sound is heard, replace the fuel tank pump (Refer to GROUP 13C - Fuel Tank Pump Assembly Disassembly and Reassembly P.13C-7).

NOTE: As the fuel tank pump is an in-tank type, the fuel tank pump sound is hard to hear. Remove the fuel tank cap and check from the tank inlet.

- (6) Check for fuel pressure by pinching the fuel high pressure hose with fingertips.
- (7) Connect the fuel tank pump assembly connector.
- (8) Tighten the service hole cover mounting screws and install the service hole cover.
- (9) Install the rear seat cushion. (Refer to GROUP 52A - Rear Seat P.52A-30).

COMPONENT LOCATION

M1131002100763

Name	Symbol	Name	Symbol
A/C relay	G	Fuel pump relay (1) and (2)	Q
A/C switch	T	Idle speed control servo	E
Camshaft position sensor	N	Ignition coil	K
Crank angle sensor	B	Injector	C
Detonation sensor	I	Manifold absolute pressure sensor (with intake air temperature sensor)	D
Diagnosis connector	S	Oxygen sensor (front)	J
EGR control solenoid valve	H	Oxygen sensor (rear)	P
Engine coolant temperature sensor	M	Power steering fluid pressure switch	A
Engine-ECU <M/T> or Engine-A/T-ECU <A/T>	U	Purge control solenoid valve	E
Engine warming lamp (check engine lamp)	R	Throttle position sensor	D
		Vehicle speed sensor <M/T>	F

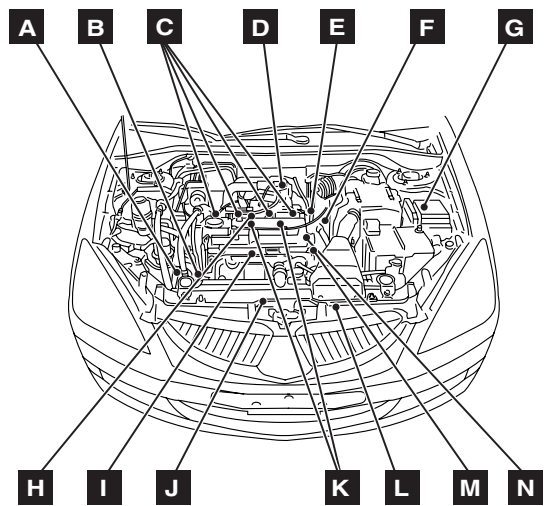

<L. H. drive vehicles>

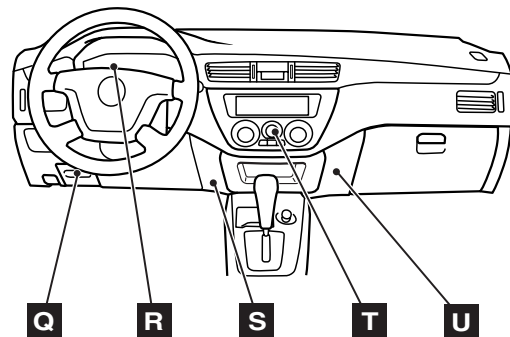

<R. H. drive vehicles>

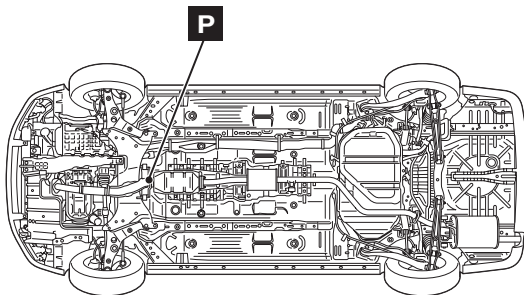
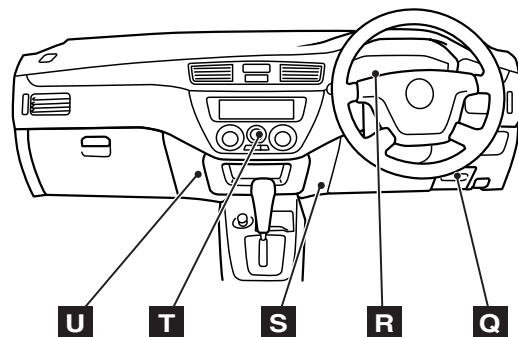

ENGINE CONTROL RELAY CONTINUITY CHECK

M113105000851

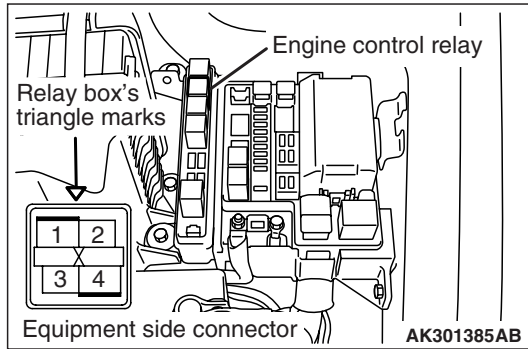

Tester Connection Terminal	Battery Voltage	Normal State
1 - 4	No Voltage	Continuity (2 Ω or less)
2 - 3	No Voltage	No continuity
	Voltage (Connect positive (+) terminal of battery to terminal No. 3 and negative (-) terminal of battery to terminal No. 2.)	Continuity (2 Ω or less)

Tester Connection Terminal	Battery Voltage	Normal State
2 - 3	No Voltage	Continuity (2 Ω or less)
1 - 4	No Voltage	No continuity
	Voltage (Connect positive (+) terminal of battery to terminal No. 3 and negative (-) terminal of battery to terminal No. 2.)	Continuity (2 Ω or less)

INTAKE AIR TEMPERATURE SENSOR CHECK

M1131002800869

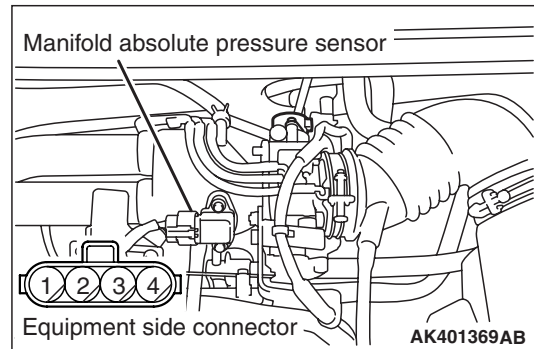

FUEL PUMP RELAY CONTINUITY CHECK

M1131033000870

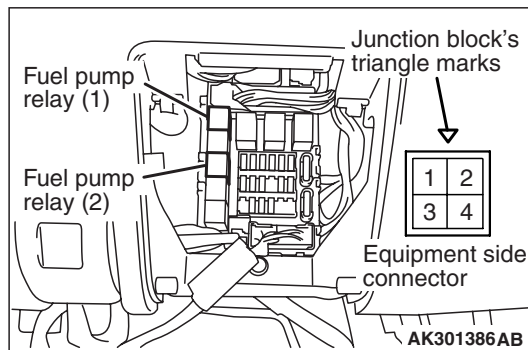

1. Disconnect the manifold absolute pressure sensor connector.
2. Measure resistance between terminals No. 1 and No. 3.

Standard value:

- 13 – 17 kΩ (at - 20° C)
- 5.3 – 6.7 kΩ (at 0° C)
- 2.3 – 3.0 kΩ (at 20° C)
- 1.0 – 1.5 kΩ (at 40° C)
- 0.56 – 0.76 kΩ (at 60° C)
- 0.30 – 0.42 kΩ (at 80° C)

3. Remove the manifold absolute pressure sensor

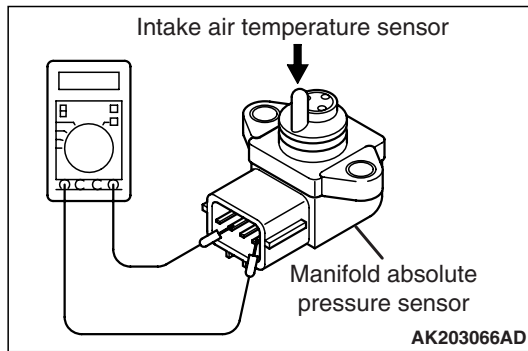

4. Measure resistance while heating the sensor using a hair drier.

NORMAL CONDITION:

Temperature (°C)	Resistance (kΩ)
Higher	Smaller

5. If the value deviates from the standard value or the resistance remains unchanged, replace the manifold absolute sensor assembly.
6. Install the manifold absolute sensor and tighten it to the specified torque.

Tightening torque: 5.0 ± 1.0 N·m

ENGINE COOLANT TEMPERATURE SENSOR CHECK

M1131003100476

CAUTION

Be careful not to touch the connector (resin section) with the tool when removing and installing.

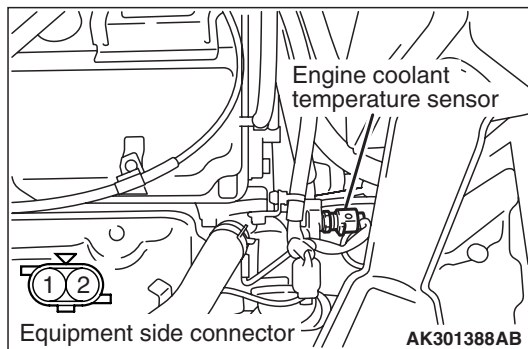

1. Remove the engine coolant temperature sensor.

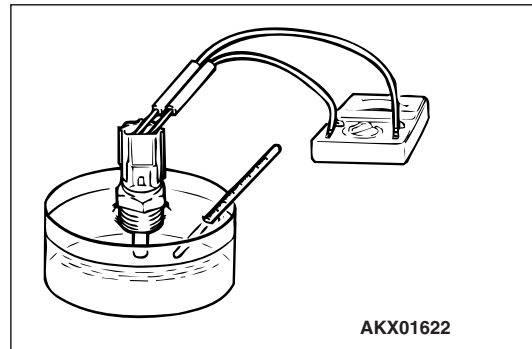

2. With temperature sensing portion of engine coolant temperature sensor immersed in hot water, check resistance.

Standard value:

14 – 17 kΩ (at – 20° C)

5.1 – 6.5 kΩ (at 0° C)

2.1 – 2.7 kΩ (at 20° C)

0.9 – 1.3 kΩ (at 40° C)

0.48 – 0.68 kΩ (at 60° C)

0.26 – 0.36 kΩ (at 80° C)

3. If the resistance deviates from the standard value greatly, replace the sensor.

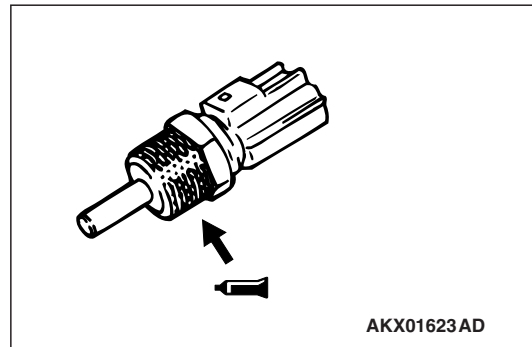

4. Apply sealant to threaded portion.

Specified sealant:

3M NUT Locking Part No. 4171 or equivalent

5. Install the engine coolant temperature sensor and tighten it to the specified torque.

Tightening torque: 29 ± 10 N·m

THROTTLE POSITION SENSOR CHECK

M1131003200525

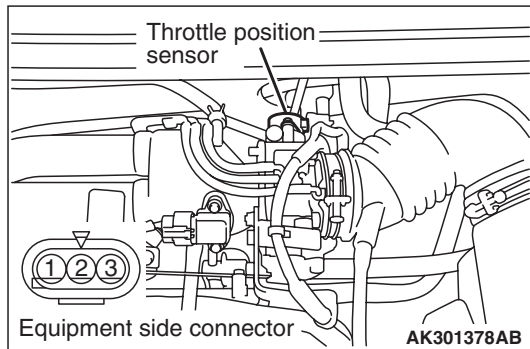

1. Disconnect the throttle position sensor connector.
2. Measure the resistance between the throttle position sensor side connector terminal No. 1 and terminal No. 4.

Standard value: 2.0 – 4.0 k Ω

3. Measure the resistance between the throttle position sensor side connector terminal No. 2 and terminal No. 4.

Normal condition:

Throttle valve slowly open until fully open from the idle position	Changes smoothly in proportion to the opening angle of the throttle valve
--	---

4. If the resistance is outside the standard value, or if it doesn't change smoothly, replace the throttle position sensor.

NOTE: For the throttle position sensor adjustment procedure, refer to P.13A-398.

OXYGEN SENSOR CHECK

M1131005000646

Oxygen sensor (front)

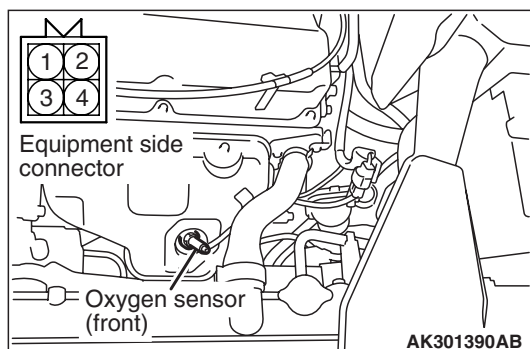

1. Disconnect the oxygen sensor connector and connect the special tool Test harness (MD998464) to the connector on the oxygen sensor side.
2. Make sure that there is continuity (4.5 – 8.0 Ω at 20° C) between terminal No. 1 (red clip of special tool) and No. 3 (blue clip of special tool) on the oxygen sensor connector.

3. If there is no continuity, replace the oxygen sensor.
4. Warm up the engine until engine coolant is 80° C or higher.

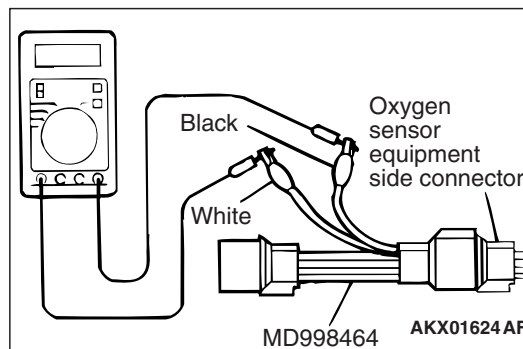

5. Perform a tracing for 5 minutes or more with the engine speed of 4,500 r/min.
6. Connect a digital voltage meter between terminal No. 2 (black clip of special tool) and No. 4 (white clip of special tool).
7. While repeatedly racing the engine, measure the oxygen sensor output voltage.

Standard value:

Engine	Oxygen sensor output voltage	Remarks
When racing the engine	0.6 – 1.0 V	If you make the air-fuel ratio rich by racing the engine repeatedly, a normal oxygen sensor will output a voltage of 0.6 – 1.0 V.

CAUTION

- Be very careful when connecting the jumper wire; incorrect connection can damage the oxygen sensor.
- Be careful the heater is broken when voltage of beyond 8V is applied to the oxygen sensor heater.

NOTE: If the sufficiently high temperature (of approximate 400° C or more) is not reached although the oxygen sensor is normal, the output voltage would be possibly low although the rich air-fuel ratio. Therefore, if the output voltage is low, use a jumper wire to connect the terminal No.1 (red clip of special tool) and the terminal No. 3 (blue clip of special tool) of the oxygen sensor with a (+) terminal and (-) terminal of 8 V power supply respectively, then check again.

8. If the sensor is defective, replace the oxygen sensor.

NOTE: For removal and installation of the oxygen sensor, refer to GROUP 15 – Exhaust Manifold.

P.15-8.

Oxygen sensor (rear)

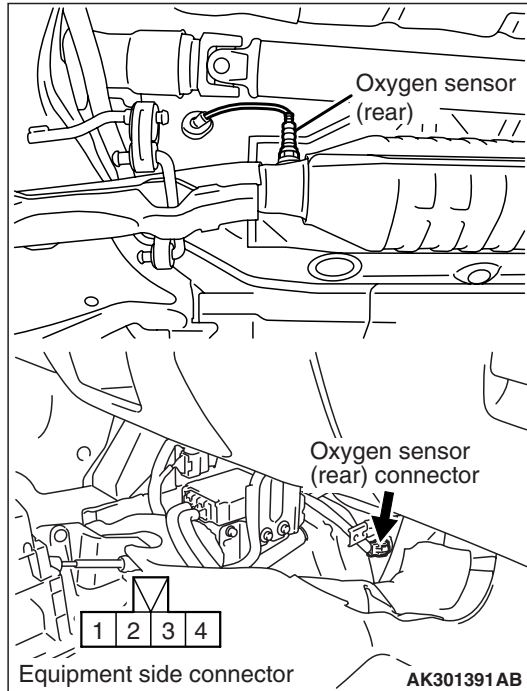

1. Disconnect the oxygen sensor connector and connect the special tool Test harness (MB991658) to the connector on the oxygen sensor side.
2. Make sure that there is continuity (4.5 – 8.0 Ω at 20°C) between terminal No. 1 and terminal No. 3 on the oxygen sensor connector.
3. If there is no continuity, replace the oxygen sensor.
4. Warm up the engine until engine coolant is 80°C or higher.

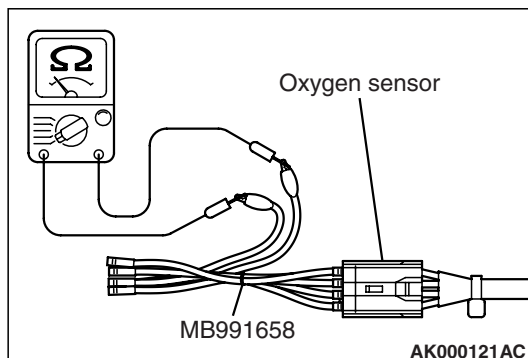

5. Use a jumper wire to connect terminal No. 2 of the oxygen sensor connector to the battery (+) terminal and terminal No. 1 to the battery (-) terminal.

6. Connect a digital voltage meter between terminal No. 3 and terminal No. 4.
7. While repeatedly racing the engine, measure the oxygen sensor output voltage.

Standard value:

Engine	Oxygen sensor output voltage	Remarks
When racing the engine	0.6 – 1.0 V	If you make the air/fuel ratio rich by racing the engine repeatedly, a normal oxygen sensor will output a voltage of 0.6 – 1.0 V.

CAUTION

- Be very careful when connecting the jumper wire; incorrect connection can damage the oxygen sensor.
- Be careful the heater is broken when voltage of beyond 12V is applied to the oxygen sensor heater.

NOTE: If the sufficiently high temperature (of approximate 400°C or more) is not reached although the oxygen sensor is normal, the output voltage would be possibly low although the rich air-fuel ratio. Therefore, if the output voltage is low, use a jumper wire to connect the terminal No.1 (red clip of special tool) and the terminal No. 3 (blue clip of special tool) of the oxygen sensor with a (+) terminal and (-) terminal of 12 V power supply respectively, then check again.

8. If the sensor is defective, replace the oxygen sensor.

NOTE: For removal and installation of the oxygen sensor, refer to GROUP 15 – Exhaust Pipe and Main Muffler P.15-11.

INJECTOR CHECK

M1131005200468

Check the Operation Sound

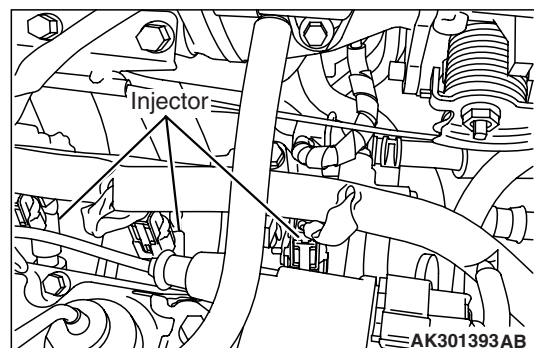

1. Use a stethoscope to listen to the operation sound (clicking) of the injectors while the engine is idling or cranking.

CAUTION

Beware that the operation sounds of other injectors can be heard even if the injector that is being inspected might not be operating.

2. Verify that the operation sound increases with the engine speed.

NOTE: If the operating sound cannot be heard, inspect the injector actuation circuit.

Measurement of Resistance between Terminals

1. Disconnect the injector connector.
2. Measure the resistance between terminals.
Standard value: 13 – 16 Ω (at 20° C)
3. Connect the injector connector.

Check the Injection Condition

1. Following the steps below, bleed out the residual pressure within the fuel pipe line to prevent flow of the fuel (Refer to P.13A-401).
2. Remove the injector.
3. Assemble the following special tools as shown in Fig.
 - Injector test set (MD998706)
 - Injector test harness (MB991607)
 - Injector test adaptor (MD998741)
 - Injector test holder assembly (MB991976)

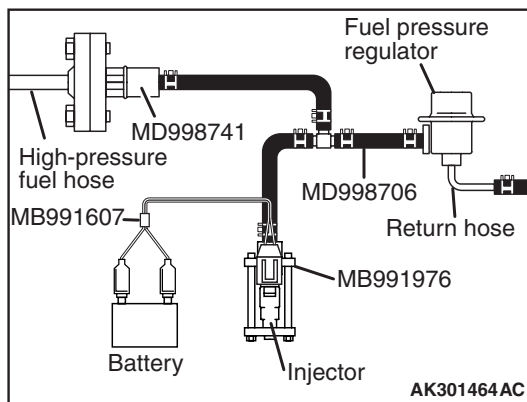

4. Connect the M.U.T.-II/III to the diagnosis connector.
5. Turn the ignition switch to "ON" position (But do not start the engine).
6. Select "Item No. 07" from the M.U.T.-II/III actuator test to drive the fuel pump.

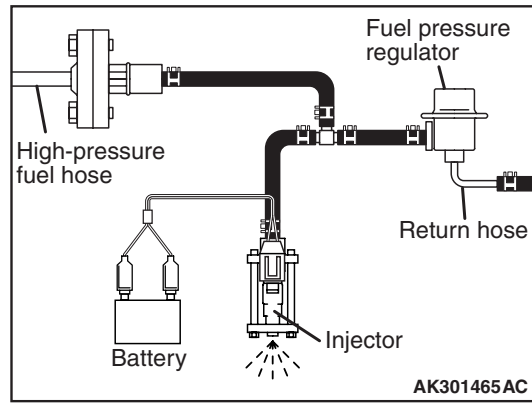

7. Activate the injector and check the atomized spray condition of the fuel.
The condition can be considered satisfactory unless it is extremely poor.
8. Stop the actuation of the injector, and check for leakage from the injector's nozzle.
Standard value: 1 drop or less per minute
9. Activate the injector without activating the fuel pump; then, when the spray emission of fuel from the injector stops, disconnect the special tool and restore it to its original condition.
10. Disconnect the M.U.T.-II/III.

IDLE SPEED CONTROL (ISC) SERVO (STEPPER MOTOR) CHECK

M1131005400547

Check the Operation Sound

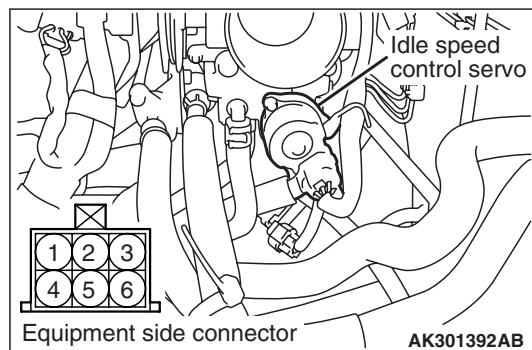

1. Check that the engine coolant temperature is 20° C or below.
NOTE: Disconnecting the engine coolant temperature sensor connector and connecting the harness-side of the connector to another engine coolant temperature sensor that is at 20° C or below is also okay.
2. Check that the operation sound of the stepper motor can be heard after the ignition is turned to the "ON" position (but without starting the engine).
3. If the operation sound cannot be heard, check the stepper motor's activation circuit.

If the circuit is normal, it is probable that there is a malfunction of the stepper motor or of the engine-ECU<M/T> or engine-A/T-ECU<A/T> .

Check the Coil Resistance

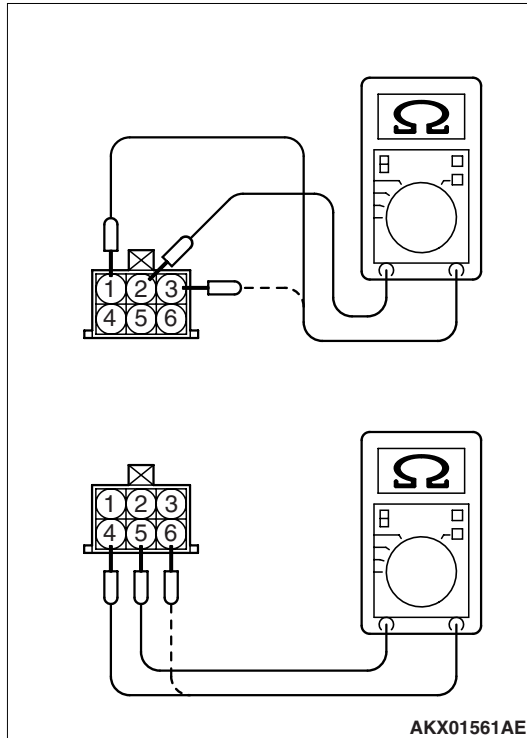

1. Disconnect the idle speed control servo connector.
2. Measure the resistance between terminal No. 2 and either terminal No. 1 or terminal No. 3 of the connector at the idle speed control servo side.
Standard value: 28 – 33 Ω (at 20° C)
3. Measure the resistance between terminal No. 5 and either terminal No. 6 or terminal No. 4 of the connector at the idle speed control servo side.
Standard value: 28 – 33 Ω (at 20° C)
4. If the resistance deviates from the standard value greatly, replace the idle speed control servo.

Operation Check

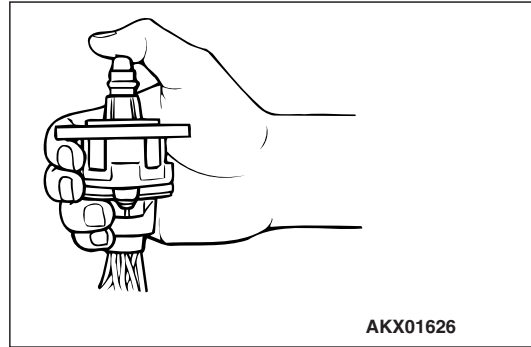

1. Remove the throttle body.
2. Remove the stepper motor.
3. Connect the special tool Test harness (MB991709) to the idle speed control servo connector.
4. Connect the positive (+) terminal of a power supply (approximately 6 V) to the terminals No. 2 and No. 5.
5. With the idle speed control servo as shown in the illustration, connect the negative (–) terminal of the power supply to each clip as described in the following steps, and check whether or not a vibrating feeling (a feeling of very slight vibration of the stepper motor) is generated as a result of the activation of the stepper motor.
 - (1) Connect the negative (–) terminal of the power supply to the terminal No. 1 and terminal No. 4.
 - (2) Connect the negative (–) terminal of the power supply to the terminal No. 3 and terminal No. 4.
 - (3) Connect the negative (–) terminal of the power supply to the terminal No. 3 and terminal No. 6.
 - (4) Connect the negative (–) terminal of the power supply to the terminal No. 1 and terminal No. 6.
 - (5) Connect the negative (–) terminal of the power supply to the terminal No. 1 and terminal No. 4.
 - (6) Repeat the tests in sequence from (5) to (1).
6. If vibration is detected during the test, the stepper motor can be considered to be normal.

INJECTOR

REMOVAL AND INSTALLATION

M1131007101556

CAUTION

When the fuel injector replacement is performed, use the M.U.T.-II/III to initialise the learning value (Refer to GROUP 00, Precautions Before Service –Initialisation Procedure for Learning Value in MPI Engine P.00-19).

Pre-removal Operation

- Fuel Discharge Prevention (Refer to P.13A-401).
- Air Cleaner Body and Air Cleaner To Throttle Body Duct Removal (Refer to GROUP 15 P.15-3).

Post-installation Operation

- Air Cleaner Body and Air Cleaner To Throttle Body Duct Installation (Refer to GROUP 15 P.15-3).
- Accelerator Cable Adjustment (Refer to GROUP 17 - On-vehicle Service P.17-2).
- Fuel Leakage Inspection

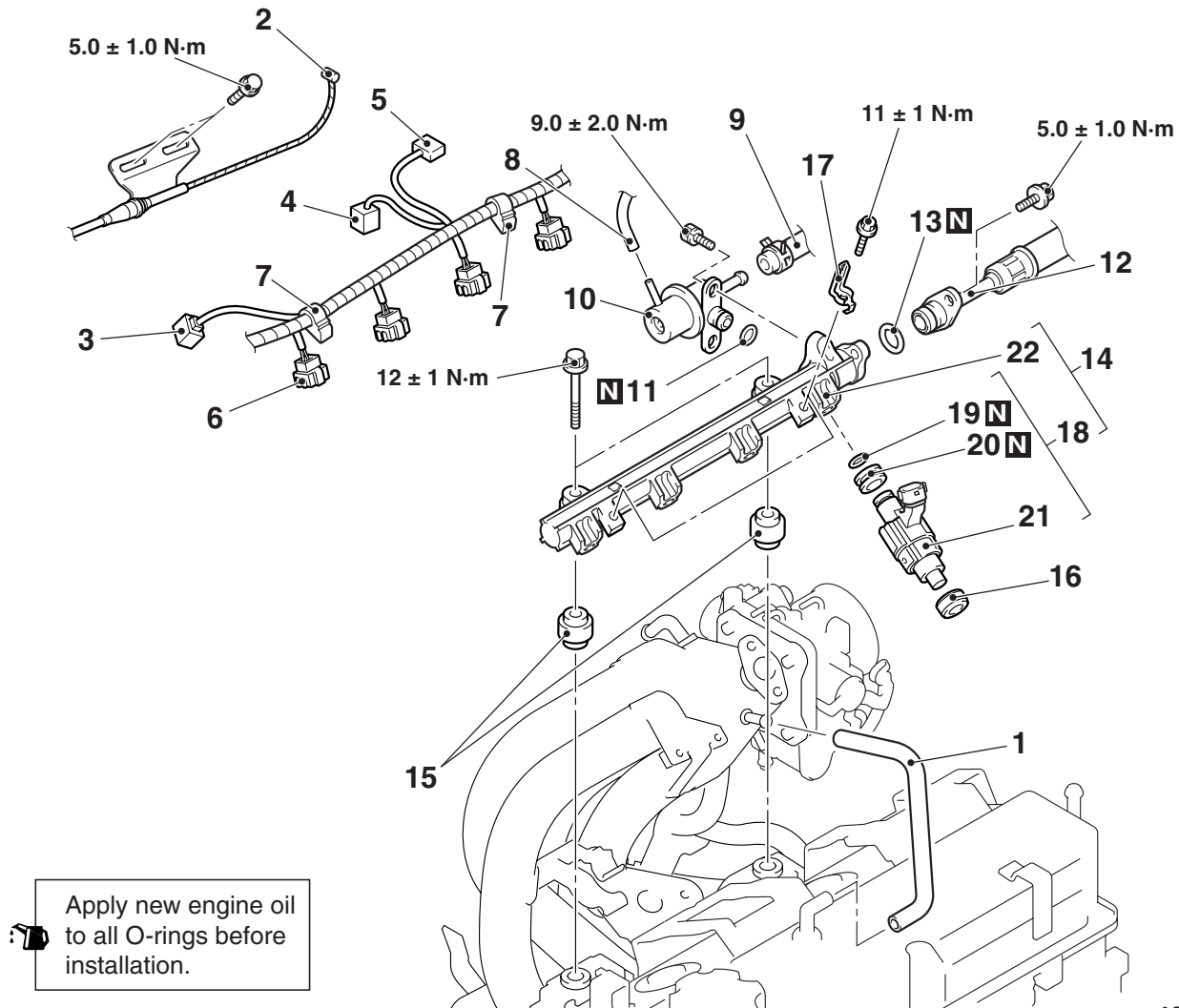

Apply new engine oil to all O-rings before installation.

Removal steps

1. Rocker cover PCV hose
2. Accelerator cable connection
3. Engine control detonation sensor connector
4. Emission solenoid valve (EGR system) connector
5. Inlet manifold absolute pressure sensor connector

Removal steps (Continued)

6. Fuel injector connector
 7. Control wiring harness clamp connection
 8. Emission control equip hose connection
 9. Fuel return line hose connection
 10. MPI delivery pipe pressure regulator
- >>A<<

AC207591AC

Removal steps (Continued)

- >>A<< 11. Fuel regulator O-ring
- >>A<< 12. Fuel high-pressure hose connection
- >>A<< 13. Fuel line O-ring
- <<A>> 14. Fuel delivery pipe and fuel injector assembly
- 15. Fuel injector insulator
- 16. Fuel injector insulator
- 17. Fuel injector harness support bracket
- >>A<< 18. Fuel injector assembly
- >>A<< 19. Fuel injector O-ring
- 20. Fuel injector sheet
- 21. Fuel injector
- 22. Fuel delivery pipe

REMOVAL SERVICE POINT

<<A>> FUEL DELIVERY PIPE AND FUEL INJECTOR ASSEMBLY REMOVAL

 CAUTION

Do not drop the fuel injector.

Remove the fuel delivery pipe with the fuel injectors assembly attached to it.

INSTALLATION SERVICE POINT

>>A<< FUEL INJECTOR O-RING/FUEL INJECTOR ASSEMBLY/FUEL LINE O-RING/FUEL HIGH-PRESSURE HOSE/FUEL REGULATOR O-RING/MPI DELIVERY PIPE PRESSURE REGULATOR INSTALLATION

 CAUTION

Do not let the engine oil get into the fuel delivery pipe will be damaged.

1. Apply a drop of new engine oil to the O-rings.
2. Turn the fuel injectors assembly. To the right and left to install to the fuel delivery pipe. Repeat for MPI delivery pipe pressure regulator and fuel high-pressure hose. Be careful not to damage the O-ring. After installing, check that the item turns smoothly.
3. If it dose not turn smoothly, the O-ring may be trapped, remove the item, re-install it into the fuel delivery pipe and check again.
4. Tighten the MPI delivery pipe pressure regulator and fuel high-pressure hose to the specified torque.

Tightening torque:

9.0 ± 2.0 N· m <MPI delivery pipe pressure regulator>

5.0 ± 1.0 N· m <Fuel high-pressure hose>

THROTTLE BODY ASSEMBLY

REMOVAL AND INSTALLATION

M1131007701428

⚠ CAUTION

When the throttle body assembly replacement is performed, use the M.U.T.-II/III to initialise the learning value (Refer to GROUP 00, Precautions Before Service –Initialisation Procedure for Learning Value in MPI Engine P.00-19).

Pre-removal Operation

- Engine Coolant Draining (Refer to GROUP 14 - On-vehicle Service P.14-21).
- Air Cleaner To Throttle Body Duct Removal (Refer to GROUP 15 - Air Cleaner P.15-3).

Post-installation Operation

- Air Cleaner To Throttle Body Duct Installation (Refer to GROUP 15 - Air Cleaner P.15-3).
- Engine Coolant Supplying (Refer to GROUP 14 - On-vehicle Service P.14-21).
- Accelerator Cable Adjustment (Refer to GROUP 17 - On-vehicle Service P.17-2).

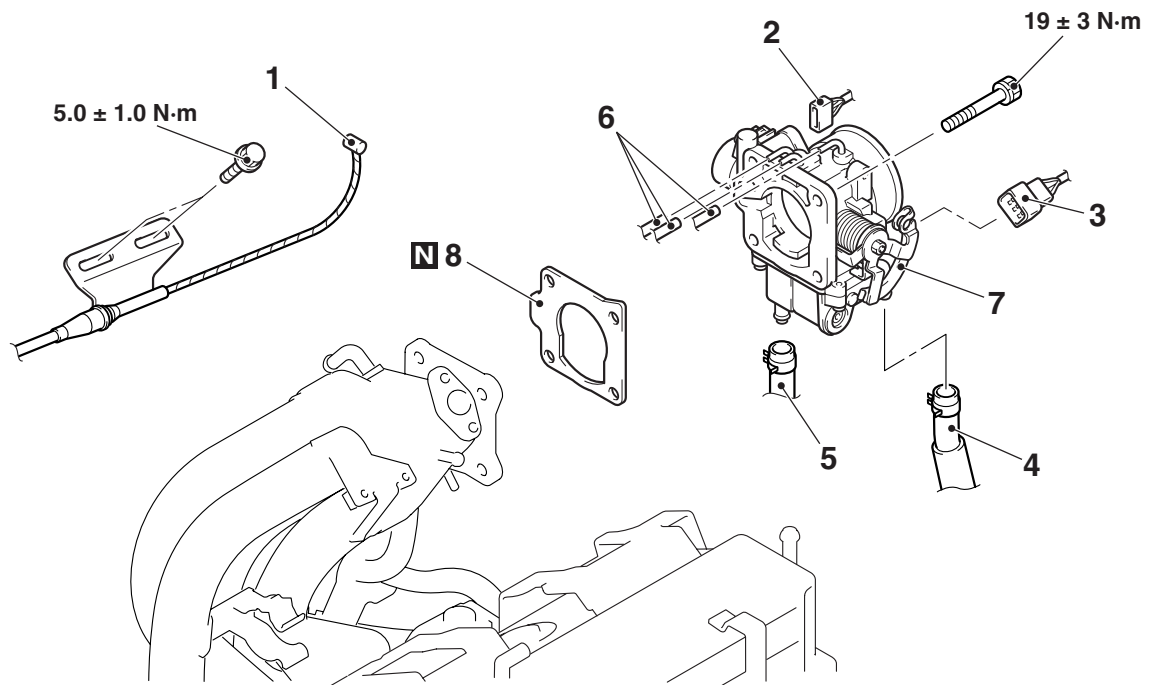

Removal steps

1. Accelerator cable connection
2. Throttle body throttle sensor connector
3. Throttle body idle speed control servo connector
4. Throttle body water feed hose connection
5. Throttle body water return hose connection
6. Emission vacuum hose connection

Removal steps (Continued)

7. Throttle body assembly
8. Throttle body gasket

INSTALLATION SERVICE POINT >>A<< THROTTLE BODY GASKET INSTALLATION

⚠ CAUTION

Poor idling etc. may result if the throttle body gasket is installed incorrectly.

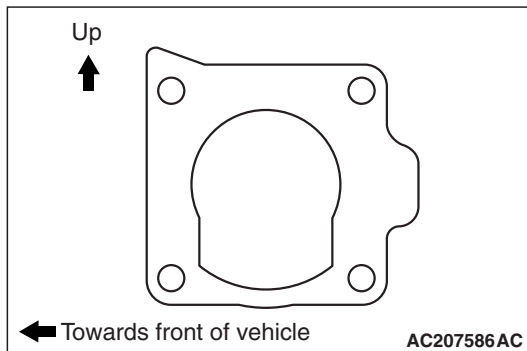

Install the throttle body gasket as shown in the illustration.

ENGINE-ECU AND ENGINE-A/T-ECU

REMOVAL AND INSTALLATION

M1131022500183

CAUTION

When the engine-ECU <M/T> or the engine-A/T-ECU <A/T> replacement is performed, always refer to GROUP 54A, General Information –Immobilizer System –Encrypted Code Registration Criteria Table [P.54A-6](#).

Pre-removal and Post-installation Operation
Globe Box and Harness Cover Removal and Installation
(Refer to GROUP 52A - Instrument Panel Assembly [P.52A-3](#)).

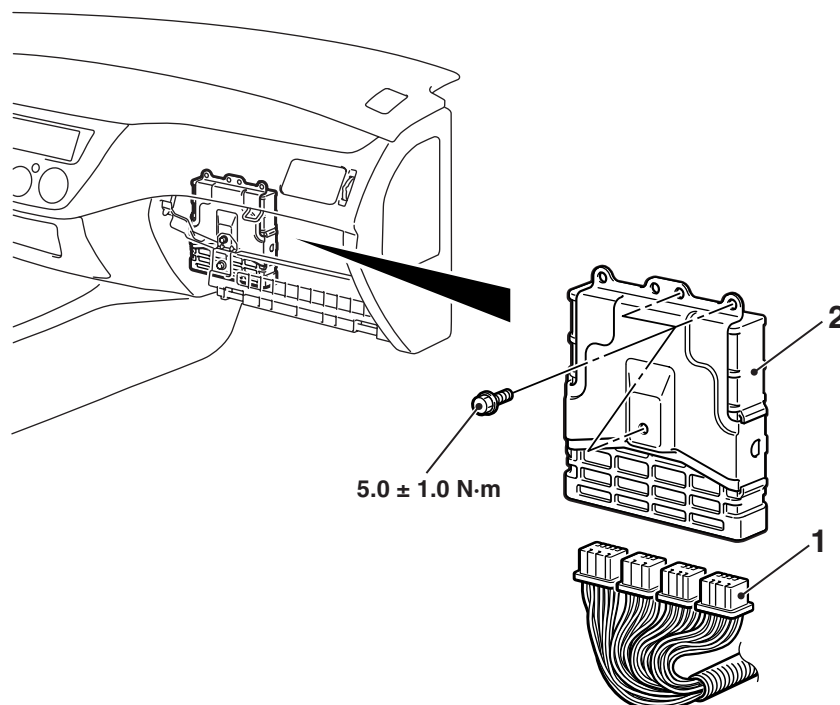

AC303053AB

REMOVAL STEPS

1. Engine-ECU connector <M/T> or Engine-A/T-ECU connector <A/T>
2. Engine-ECU <M/T> or Engine-A/T-ECU <A/T>

NOTES