

GROUP 12

**ENGINE
LUBRICATION**

CONTENTS

GENERAL INFORMATION	12-2	SPECIAL TOOLS	12-3
SERVICE SPECIFICATION	12-2	ON-VEHICLE SERVICE	12-4
LUBRICANT.....	12-2	ENGINE OIL CHECK	12-4
SEALANT.....	12-3	ENGINE OIL REPLACEMENT	12-4
		ENGINE OIL FILTER REPLACEMENT....	12-5
		OIL PRESSURE CHECK	12-5

GENERAL INFORMATION

M1121000100357

The lubrication method is a fully force-fed, full-flow filtration type. The engine oil pump is a trochoid type which is driven by the crankshaft <4G1>. The engine oil pump is a gear type which is driven by the crankshaft via the balancer timing belt <4G6>.

ENGINE OILS

Health Warning

Prolonged and repeated contact with mineral oil will result in the removal of natural fats from the skin, leading to dryness, irritation and dermatitis. In addition, used engine oil contains potentially harmful contaminants which may cause skin cancer. Adequate means of skin protection and washing facilities must be provided.

Recommended Precautions

The most effective precaution is to adapt working practices which prevent, as far as practicable, the risk of skin contact with mineral oils, for example by using enclosed systems for handling used engine oil and by degreasing components, where practicable, before handling them. Other precautions:

- Avoid prolonged and repeated contact with oils, particularly used engine oils.
- Wear protective clothing, including impervious gloves where practicable.

- Avoid contaminating clothes, particularly underpants, with oil.
- Do not put oily rags in pockets, the use of overalls without pockets will avoid this.
- Do not wear heavily soiled clothing and oil-impregnated foot-wear. Overalls must be cleaned regularly and kept separate from personal clothing.
- Where there is a risk of eye contact, eye protection should be worn, for example, chemical goggles or face shields; in addition an eye wash facility should be provided.
- Obtain first aid treatment immediately for open cuts and wounds.
- Wash regularly with soap and water to ensure all oil is removed, especially before meals (skin cleansers and nail brushes will help). After cleaning, the application of preparations containing lanolin to replace the natural skin oils is advised.
- Do not use petrol, kerosine, diesel fuel, gas oil, thinners or solvents for cleaning skin.
- Use barrier creams, applying them before each work period, to help the removal of oil from the skin after work.
- If skin disorders develop, obtain medical advice without delay.

SERVICE SPECIFICATION

M1121000300232

Item		Standard value
Oil pressure kPa	at idle	29 or more
	at 3,500 r/min	294 – 686

LUBRICANT

M1121000401049

Item		Specification	
Engine oil ACEA classification		A1/B1, A3/B3, A3/B4 or A5/B5	
Engine oil API classification		SG or higher	
Engine oil quantity L	4G1	Oil filter	0.3
		Total	3.3
	4G6	Oil filter	0.3
		Total	4.3

SEALANT

M1121000500258

Item	Specified sealant	Remark
Oil pressure switch	3M ATD Part No. 8660 or equivalent	Semi-drying sealant

SPECIAL TOOLS

M1121000600675

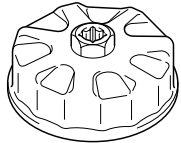
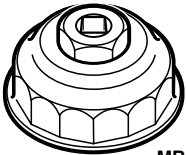
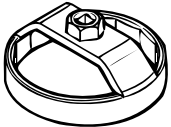
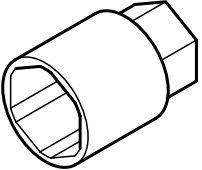
Tool	Number	Name	Use
 <p>B991396</p>	MB991396	Oil filter wrench	Removal and installation of engine oil filter (When using the engine oil filter of MD360935)
 <p>MB991828</p>	MB991828	Oil filter wrench	Removal and installation of engine oil filter (When using the engine oil filter of MD348631 and MD365876)
 <p>MB991610</p>	MB991610	Oil filter wrench	Removal and installation of engine oil filter (When using the engine oil filter of MD356000)
	MD998012	Oil pressure switch wrench	Removal and installation of oil pressure switch

ON-VEHICLE SERVICE

ENGINE OIL CHECK

M1121000900342

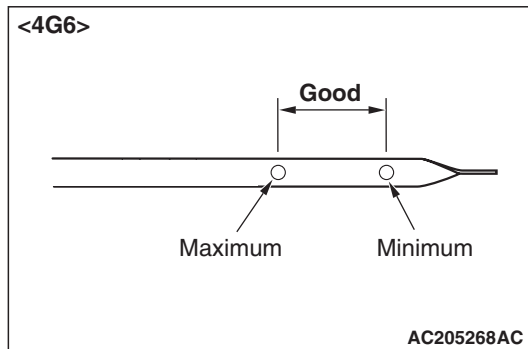
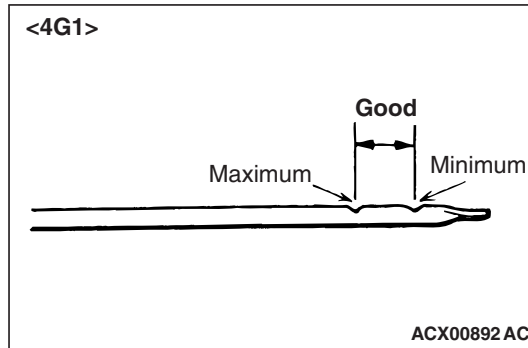

1. Pull out the engine oil level gauge slowly and check that the oil level is in the illustrated range.
2. Check that the oil is not excessively dirty, that there is no coolant or petrol mixed in, and that it has sufficient viscosity.

ENGINE OIL REPLACEMENT

M1121001001099

1. Start the engine and allow it to warm up until the temperature of the coolant reaches 80 °C to 90 °C.
2. Remove the engine oil filler cap.

CAUTION

Use care as engine oil could be hot.

3. Remove the engine oil pan drain plug to drain engine oil.

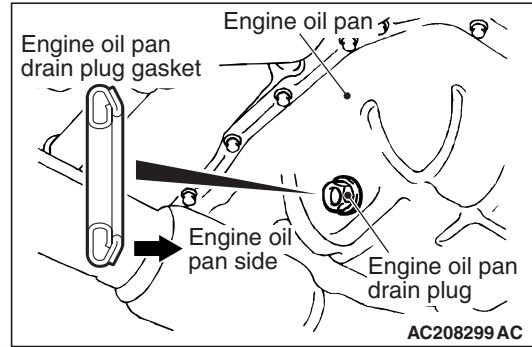

4. Install a new engine oil pan drain plug gasket so that it faces in the direction shown in the illustration, and then tighten the engine oil pan drain plug to the specified torque.

Tightening torque: 39 ± 5 N·m

NOTE: Install the engine oil pan drain plug gasket so it faces in the direction shown in the illustration.

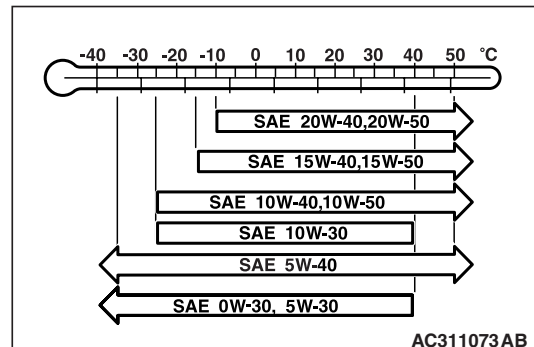

5. Refill with specified quantity of engine oil.

Specified engine oil (ACEA classification):

A1/B1, A3/B3, A3/B4 or A5/B5

Specified engine oil (API classification): SG or higher

Total quantity (Includes volume inside engine oil filter):

3.3 L <4G1>

4.3 L <4G6>

NOTE: SAE 0W-30, 5W-30, and 5W-40 engine oils can only be used if they meet ACEA A3/B3, A3/B4 or A5/B5 and API SG (or higher) specification.

6. Install the engine oil filler cap.
7. Check engine oil level.

ENGINE OIL FILTER REPLACEMENT

M1121001100383

1. Start the engine and allow it to warm up until the temperature of the coolant reaches 80 °C to 90 °C.
2. Remove the engine oil filler cap.

⚠ CAUTION

Use care as engine oil could be hot.

3. Remove the engine oil pan drain plug to drain engine oil.
4. Remove the under cover.

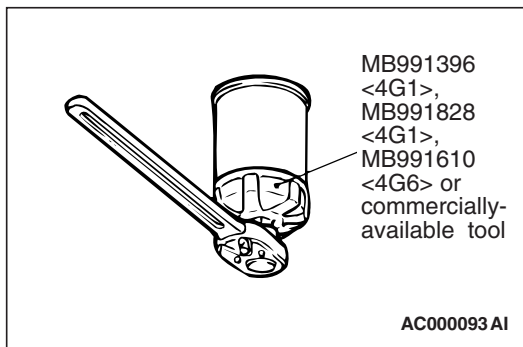

5. Use the respective tool in the following table to remove the engine oil filter.

Number	Special tool
MD348631 <4G1>	Oil filter wrench (MB991828) or equivalent
MD365876 <4G1>	
MD360935 <4G1>	Oil filter wrench (MB991396) or equivalent
MD136466 <4G6>	Commercially- available tool
MD322508 <4G6>	
MD356000 <4G6>	Oil filter wrench (MB991610) or equivalent

6. Clean the filter bracket side mounting surface.

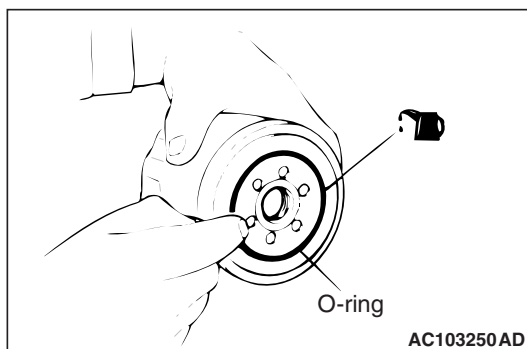

7. Apply a small amount of engine oil to the O-ring of the new engine oil filter.

8. Once the O-ring of the engine oil filter is touching the flange, use the respective tool in the following table to tighten to the specified torque.

Number	Special tool	Tightening torque
MD348631 <4G1>	Oil filter wrench (MB991828) or equivalent	Approximately 3/4 turn (16 ± 4 N· m)
MD365876 <4G1>		
MD360935 <4G1>	Oil filter wrench (MB991396) or equivalent	Approximately 1 turn (14 ± 2 N· m)
MD136466 <4G6>	Commercially- available tool	Approximately 3/4 turn (17 ± 3 N· m)
MD322508 <4G6>		
MD356000 <4G6>	Oil filter wrench (MB991610) or equivalent	Approximately 3/4 turn (14 ± 2 N· m)

9. Install the engine oil pan drain plug and refill the engine oil (Refer to P.12-4).
10. Race the engine 2-3 times, and check to be sure that no engine oil leaks from installation section of the engine oil filter.

OIL PRESSURE CHECK

M1121002300830

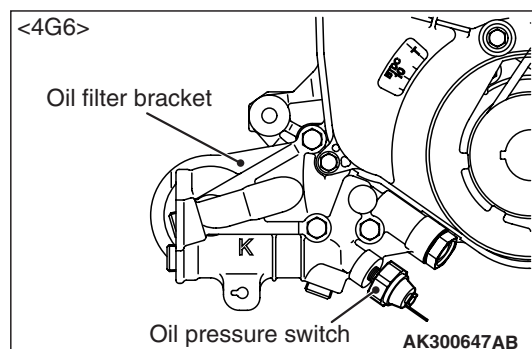
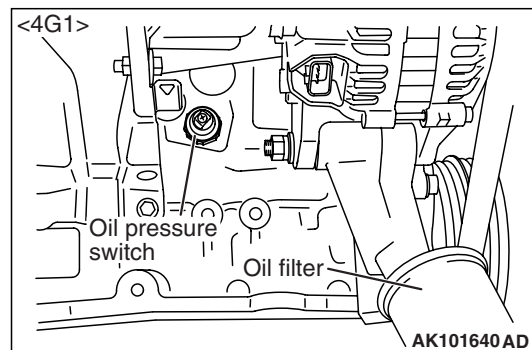

1. Check engine oil quantity.

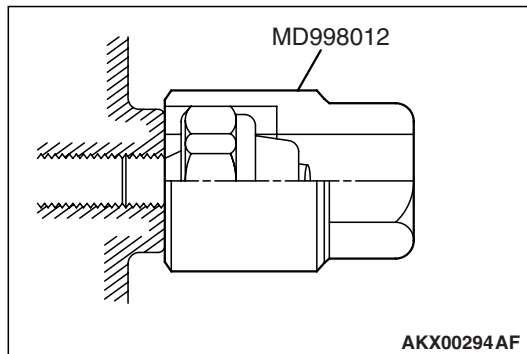

CAUTION

Since sealant is applied to the thread of oil pressure switch, take care not to damage the oil pressure switch when removing it.

- Use the special tool Oil pressure switch wrench (MD998012) to remove the oil pressure switch.

NOTE: Remove the terminal of oil pressure switch where the special tool Oil pressure switch wrench (MD998012) is not fitted.

- Install the oil pressure gauge.
- NOTE: Use an adapter of PT 1/8 thread.*
- Run the engine to warm it.
- After the engine has been warmed up, check that oil pressure is within the standard value.

Standard value:

At idle: 29 kPa or more

At 3,500 r/min: 294 – 686 kPa

- Remove the oil pressure gauge.

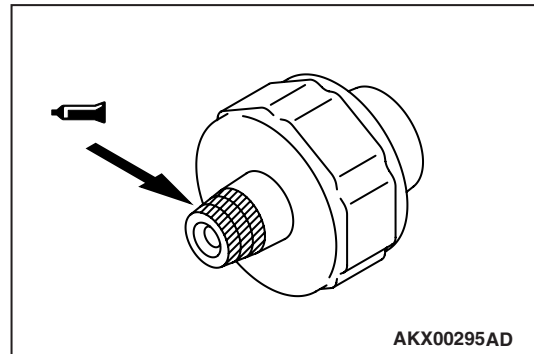

- Apply the specified sealant to the thread of oil pressure switch.

Specified sealant: 3M ATD Part No. 8660 or equivalent

CAUTION

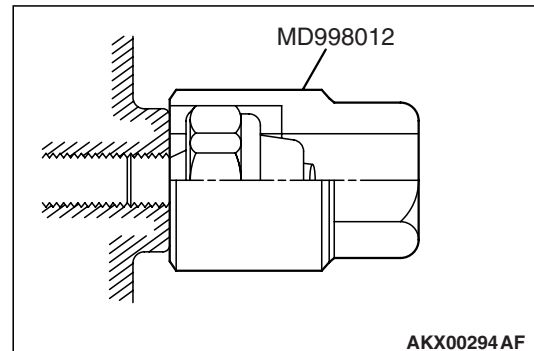

Do not start the engine within one hour after the oil pressure switch has been installed.

- Use the special tool Oil pressure switch wrench (MD998012) to tighten the oil pressure switch to the specified torque.

Tightening torque:

19 ± 3 N·m <4G1>

10 ± 2 N·m <4G6>