

GROUP 17

ENGINE AND EMISSION CONTROL

CONTENTS

ENGINE CONTROL	17-2	POSITIVE CRANKCASE VENTILATION (PCV) VALVE CHECK	17-9
GENERAL INFORMATION	17-2	EVAPORATIVE EMISSION CONTROL SYSTEM	17-9
SERVICE SPECIFICATIONS	17-2	GENERAL INFORMATION (EVAPORATIVE EMISSION CONTROL SYSTEM)	17-9
ON-VEHICLE SERVICE	17-2	COMPONENT LOCATION (EVAPORATIVE EMISSION CONTROL SYSTEM)	17-10
ACCEL CABLE CHECK AND ADJUSTMENT.....	17-2	PURGE CONTROL SYSTEM CHECK ..	17-10
ACCELERATOR CABLE AND PEDAL	17-3	PURGE PORT VACUUM CHECK	17-11
REMOVAL AND INSTALLATION	17-3	PURGE CONTROL SOLENOID VALVE CHECK.....	17-11
EMISSION CONTROL MPI	17-5	FUEL VAPOUR CANISTER REMOVAL AND INSTALLATION	17-12
GENERAL INFORMATION	17-5	EXHAUST GAS RECIRCULATION (EGR) SYSTEM	17-13
EMISSION CONTROL DEVICE REFERENCE TABLE	17-5	GENERAL INFORMATION (EGR SYSTEM)	17-13
SPECIAL TOOL	17-5	COMPONENT LOCATION (EGR SYSTEM)	17-14
VACUUM HOSE	17-6	EGR SYSTEM CHECK	17-15
VACUUM HOSE PIPING DIAGRAM	17-6	EGR VALVE CHECK	17-15
VACUUM CIRCUIT DIAGRAM	17-7	EGR PORT VACUUM CHECK <4G1> ..	17-16
VACUUM HOSE CHECK	17-7	EGR PORT VACUUM CHECK <4G6> ..	17-16
VACUUM HOSE INSTALLATION	17-8	EGR CONTROL SOLENOID VALVE CHECK <4G1>	17-16
CRANKCASE EMISSION CONTROL SYSTEM	17-8	EGR CONTROL SOLENOID VALVE CHECK <4G6>	17-17
GENERAL INFORMATION (CRANKCASE EMISSION CONTROL SYSTEM).....	17-8	EXHAUST GAS RECIRCULATION (EGR) VALVE REMOVAL AND INSTALLATION	17-18
COMPONENT LOCATION (CRANKCASE EMISSION CONTROL SYSTEM).....	17-9	CATALYTIC CONVERTER	17-19
POSITIVE CRANKCASE VENTILATION SYSTEM CHECK	17-9	REMOVAL AND INSTALLATION <4G1, 4G6-M/T>	17-19
		REMOVAL AND INSTALLATION <4G6-A/T>	17-19

ENGINE CONTROL

GENERAL INFORMATION

M1171000100277

A cable-type accelerator mechanical suspended-type pedal has been adopted.

SERVICE SPECIFICATIONS

M1171000300088

Item		Standard value
Accel cable play mm		1.0 – 2.0
Engine idle speed r/min	4G1	750 ± 50
	4G6	750 ± 100

ON-VEHICLE SERVICE

ACCEL CABLE CHECK AND ADJUSTMENT

M1171000900314

1. Turn A/C and lights OFF. Inspect and adjust at no load.
2. Warm engine until stabilized at idle.
3. Confirm idle speed is at standard value.

Standard value:**750 ± 50 r/min <4G1>****750 ± 100 r/min <4G6>**

4. Stop engine. [ignition switch: LOCK (OFF) position].
5. Confirm there are no sharp bends in the accelerator cable.
6. Check the inner cable for correct slack.

Standard value: 1.0 – 2.0 mm

7. If there is too much slack or no slack, adjust play by the following procedures.

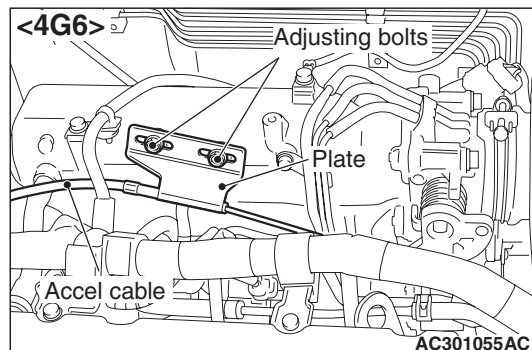
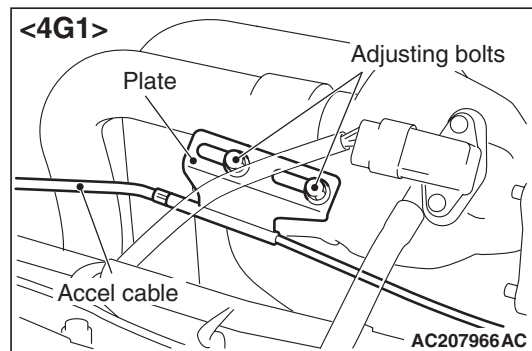

- (1) Loosen the adjusting bolts to release the cable.
- (2) Move the plate until the inner cable play is at the standard value, and then tighten the adjusting bolts.
- (3) After adjusting, check that the throttle lever is touching the stopper.

ACCELERATOR CABLE AND PEDAL

REMOVAL AND INSTALLATION

M1171001200686

Post-installation Operation

Adjusting the Accelerator Cable (Refer to P.17-2).

<L.H. drive vehicles>

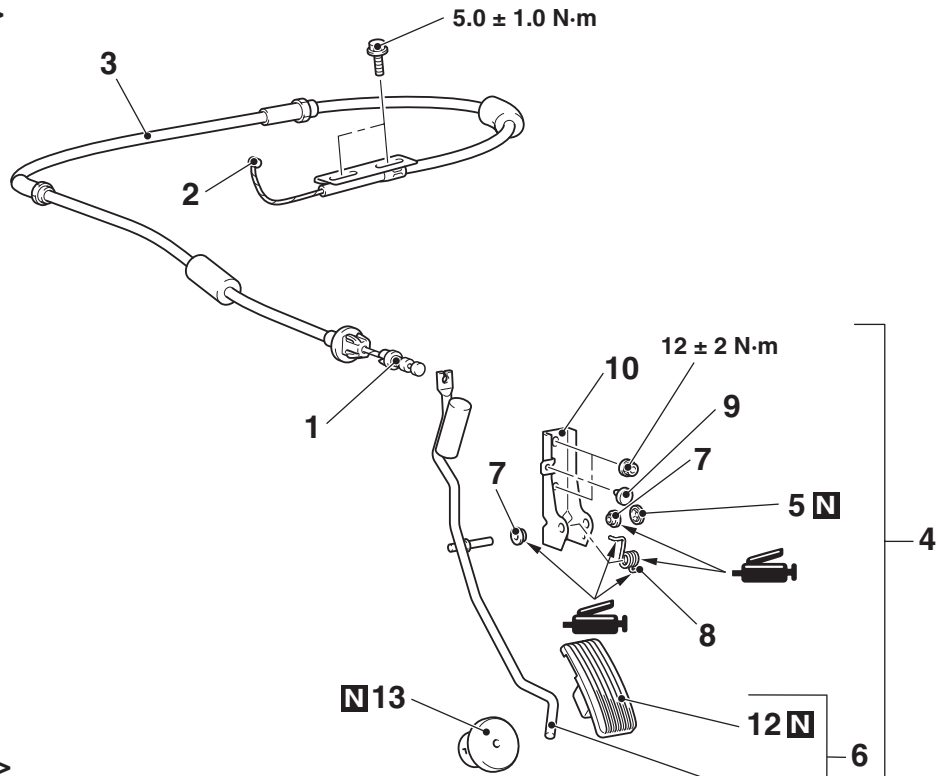

Y1060AU

<R.H. drive vehicles>

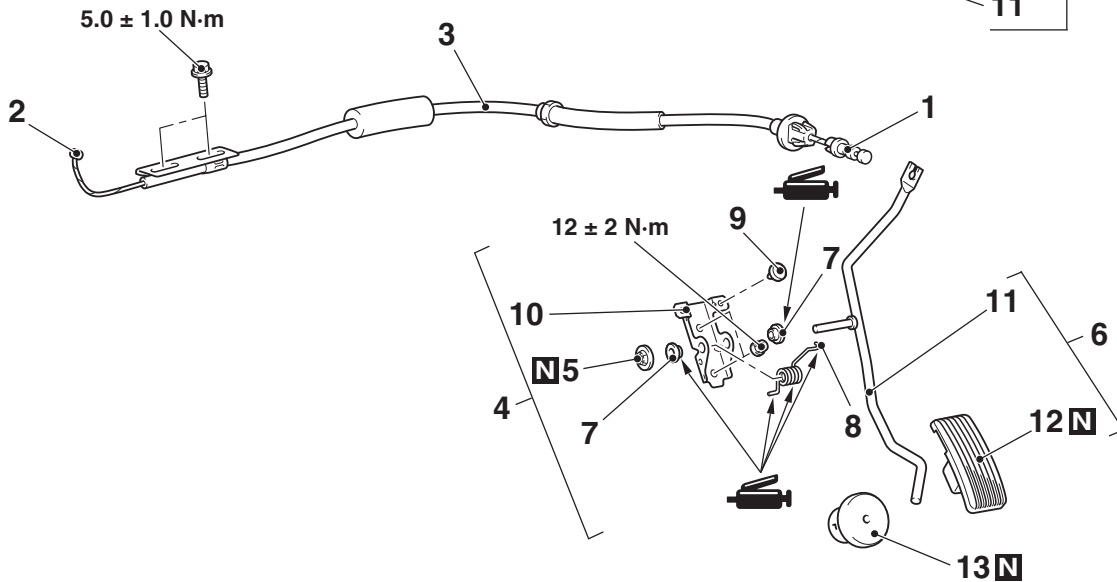

Y1059AU
AC304070 AC

**Accelerator cable assembly
removal steps**

1. Inner cable connection (Accelerator pedal side)
2. Inner cable connection (Throttle body side)
3. Accelerator cable assembly

**Accelerator pedal assembly
removal steps**

1. Inner cable connection (Accelerator pedal side)
4. Accelerator pedal assembly
5. Accelerator control equip nut
6. Accelerator pedal arm and accelerator pedal pad assembly

**Accelerator pedal assembly
removal steps (Continued)**

7. Accelerator control equip bushing
8. Accelerator pedal arm return spring
9. Accelerator pedal arm stopper
10. Accelerator pedal arm bracket
11. Accelerator pedal arm
- >>B<< 12. Accelerator pedal pad
- >>A<< 13. Accelerator pedal arm stopper

2. Install the accelerator pedal arm stopper securely by turning it clockwise until its underside contacts with the body bracket or body as shown in the figure.
3. After the installation, slightly pull the accelerator pedal arm stopper by hand to check that it cannot be removed easily (appropriate holding power: 100N or more).

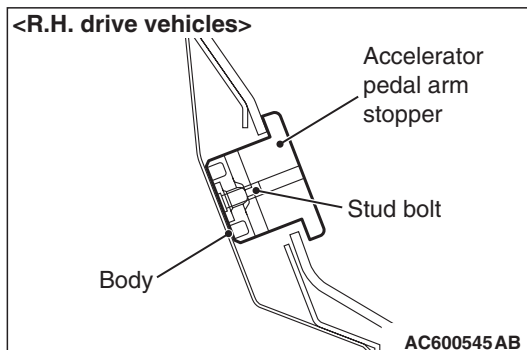
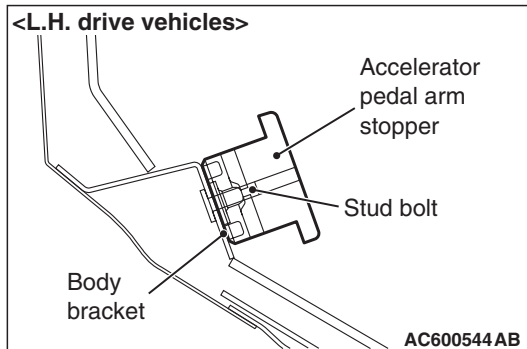
INSTALLATION SERVICE POINTS**>>A<< ACCELERATOR PEDAL ARM
STOPPER INSTALLATION**

1. Insert the accelerator pedal arm stopper straight into the stud bolt of the floor.

**>>B<< ACCEL PEDAL PAD
INSTALLATION****⚠ CAUTION**

To prevent damages to the accelerator pedal pad, warm the thumb area of the accelerator pedal pad with a dryer, etc. prior to assembling it.

NOTE: If it is difficult to assemble, apply soapy water to the thumb area to enhance the assembling process.

EMISSION CONTROL <MPI>

GENERAL INFORMATION

The emission control system consists of the following subsystems:

M1173000100370

- Crankcase emission control system
- Evaporative emission control system
- Exhaust emission control system

Items	Name	Specification
Crankcase emission control system	Positive crankcase ventilation (PCV) valve	Variable flow type (Purpose: HC reduction)
Evaporative emission control system	Canister Purge control solenoid valve	Equipped Duty cycle type solenoid valve (Purpose: HC reduction)
Exhaust emission control system	Air-fuel ratio control device - MPI system	Oxygen sensor feedback type (Purpose: CO, HC, NOx reduction)
	Exhaust gas recirculation system <ul style="list-style-type: none"> • EGR valve • EGR control solenoid valve 	Equipped Single type Duty cycle type solenoid valve (Purpose: NOx reduction)
	Catalytic converter	Monolith type (Purpose: CO, HC, NOx reduction)

EMISSION CONTROL DEVICE REFERENCE TABLE

M1173006600135

Related parts	Crankcase emission control system	Evaporative emission control system	Air/fuel ratio control system	Catalytic converter	Exhaust gas recirculation system
PCV valve	×				
Purge control solenoid valve		×			
MPI system component		×	×		
Catalytic converter				×	
EGR valve					×
EGR control solenoid valve					×

SPECIAL TOOL

M1173000600494

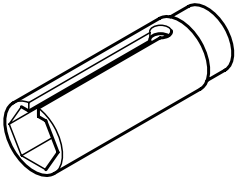
Tool	Number	Name	Use
	MD998770	Oxygen sensor wrench	Removal and installation of engine control oxygen sensor

VACUUM HOSE

VACUUM HOSE PIPING DIAGRAM

M1173000900417

<4G1>

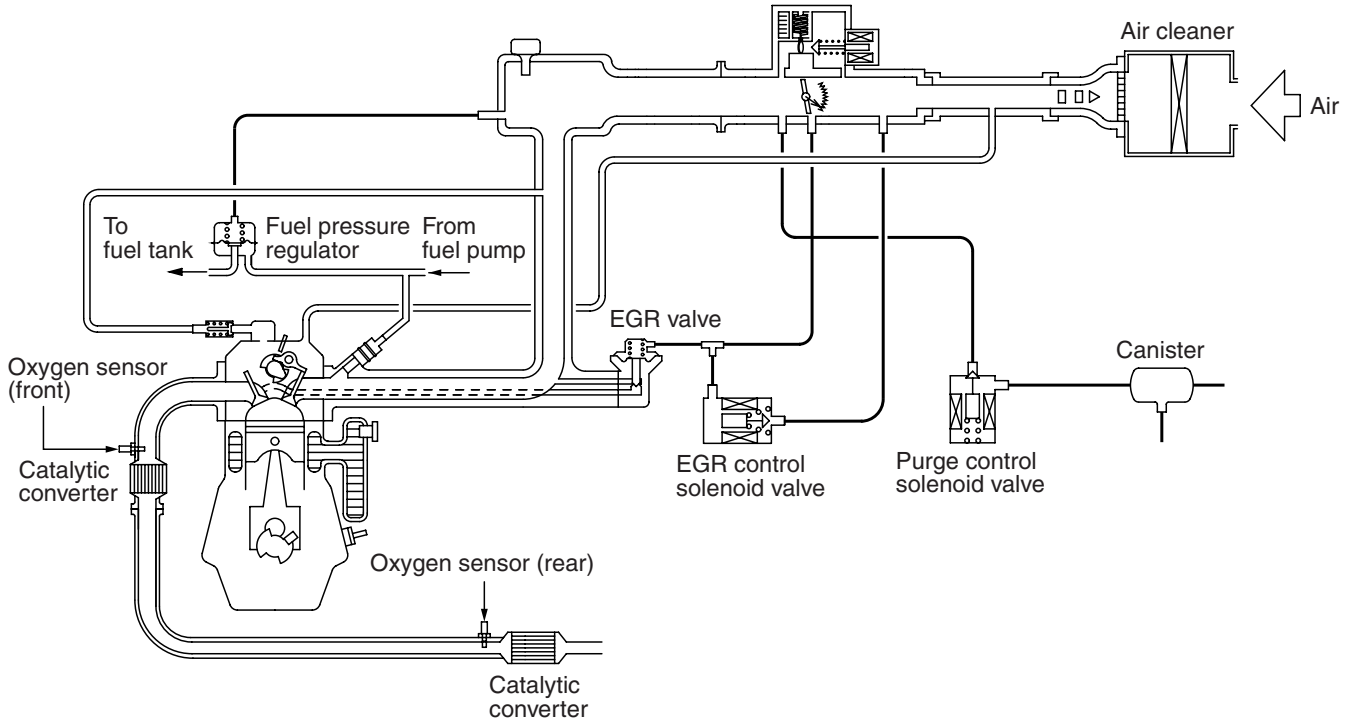

AK300964 AB

<4G6>

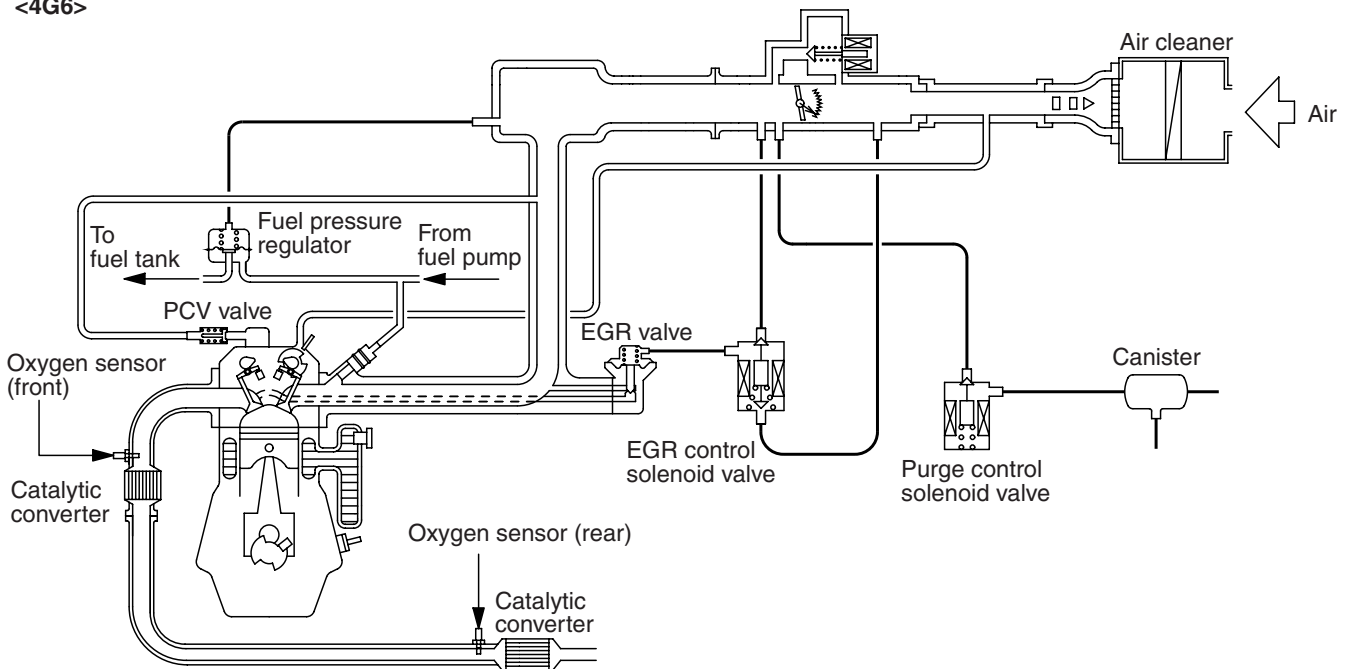

AK204364 AC

VACUUM CIRCUIT DIAGRAM

M1173007100263

<4G1>

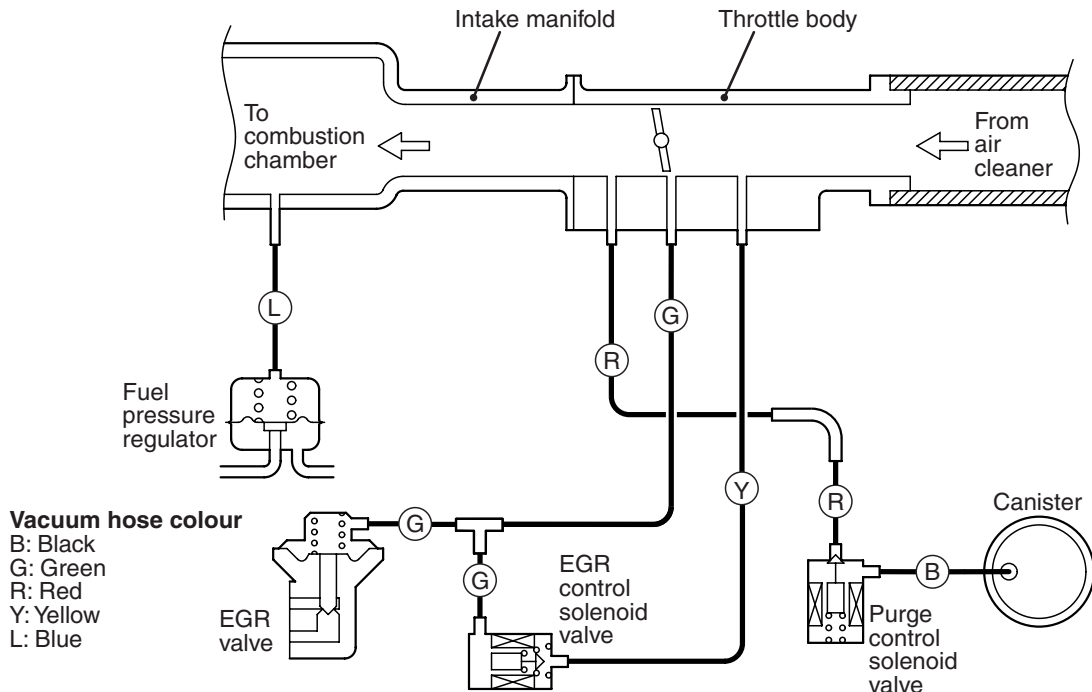

AK300765 AB

<4G6>

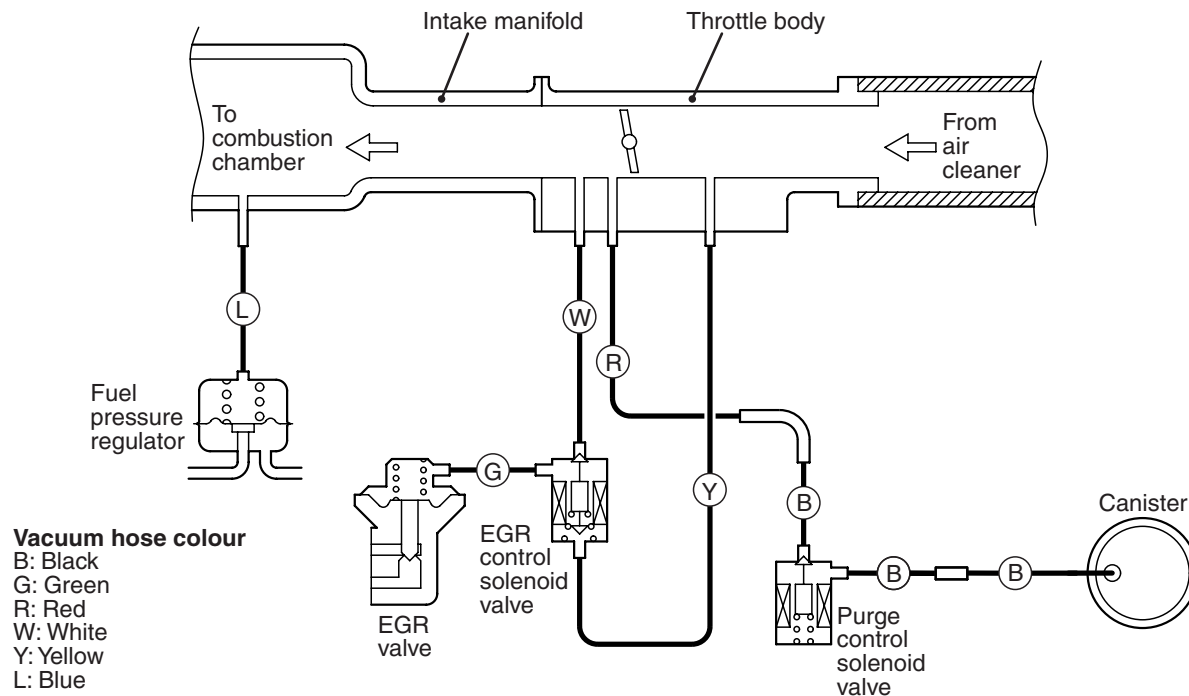

AK300766 AB

VACUUM HOSE CHECK

M1173007300159

1. Using the piping diagram as a guide, check to be sure that the vacuum hoses are correctly connected.

2. Check the connection condition of the vacuum hoses, (removed, loose, etc.) and check to be sure that there are no bends or damage.

VACUUM HOSE INSTALLATION

M1173007200107

1. When connecting the vacuum hoses, they should be securely inserted onto the nipples.
2. Connect the hoses correctly, using the vacuum hose piping diagram as a guide.

CRANKCASE EMISSION CONTROL SYSTEM**GENERAL INFORMATION (CRANKCASE EMISSION CONTROL SYSTEM)**

M1173005000237

The crankcase emission control system prevents blow-by gases from escaping inside the crankcase into the atmosphere.

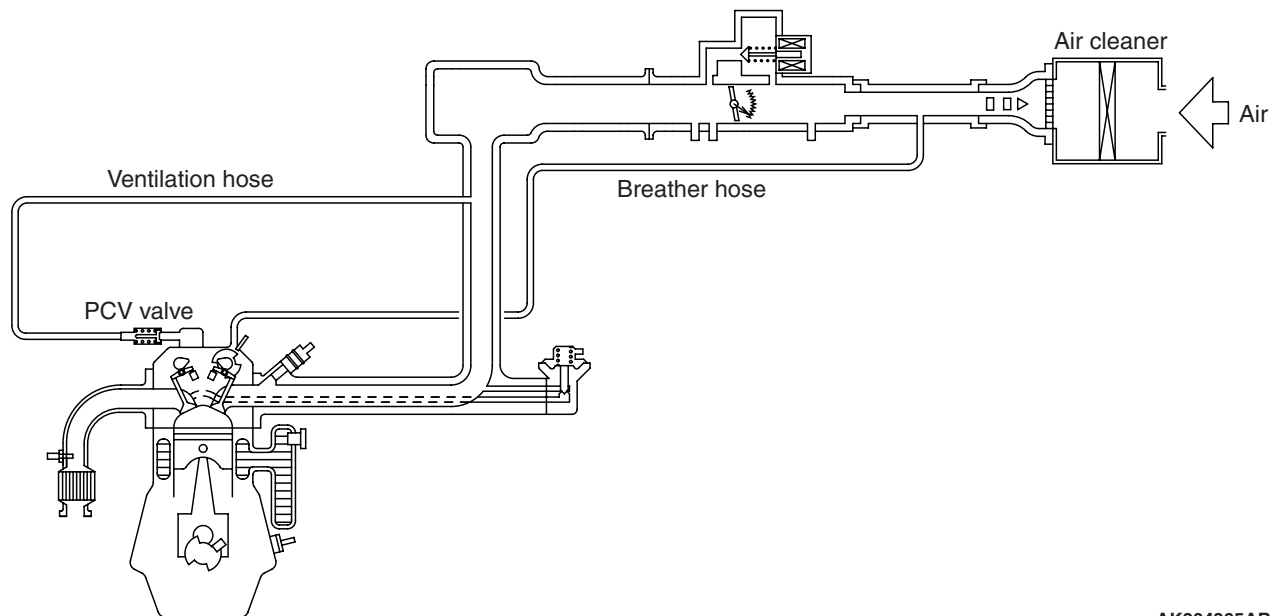
SYSTEM DIAGRAM

Fresh air is sent from the air cleaner into the crankcase through the breather hose.

The air becomes mixed with the blow-by gases inside the crankcase.

The blow-by gas inside the crankcase is drawn into the intake manifold through the positive crankcase ventilation (PCV) valve.

The PCV valve lifts the plunger according to the intake manifold vacuum so as to regulate the flow of blow-by gas properly.

In other words, the blow-by gas flow is regulated during low load engine operation to maintain engine stability, while the flow is increased during high load operation to improve the ventilation performance.

COMPONENT LOCATION (CRANKCASE EMISSION CONTROL SYSTEM)

M1173007400208

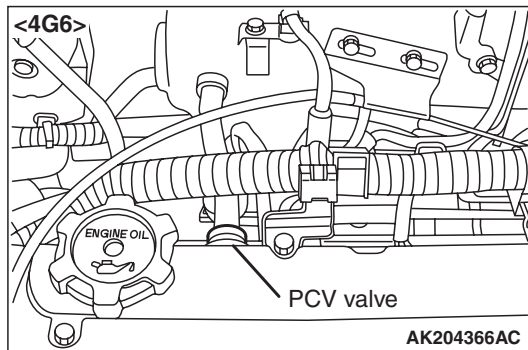
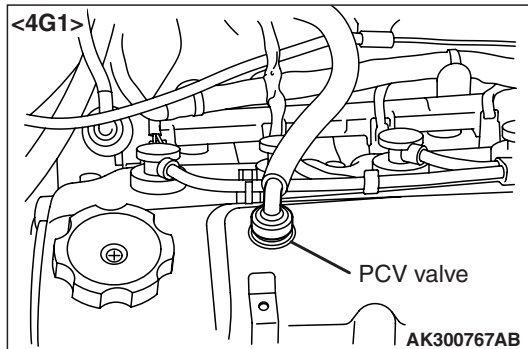

POSITIVE CRANKCASE VENTILATION SYSTEM CHECK

M1173001100179

1. Remove the ventilation hose from the PCV valve.
2. Remove the PCV valve from the rocker cover.
3. Reinstall the PCV valve at the ventilation hose.
4. Start the engine and run at idle.

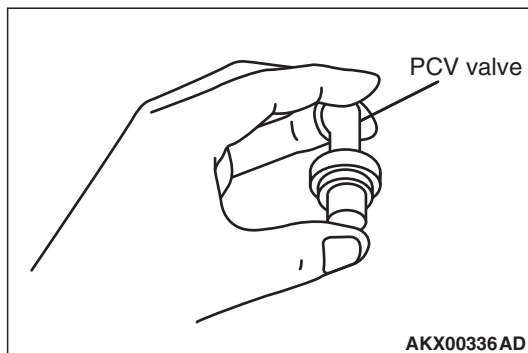

5. Place a finger at the opening of the PCV valve and check that vacuum of the intake manifold is felt.

NOTE: At this moment, the plunger in the PCV valve moves back and forth.

6. If vacuum is not felt, clean the PCV valve or replace it.

POSITIVE CRANKCASE VENTILATION (PCV) VALVE CHECK

M1173001200187

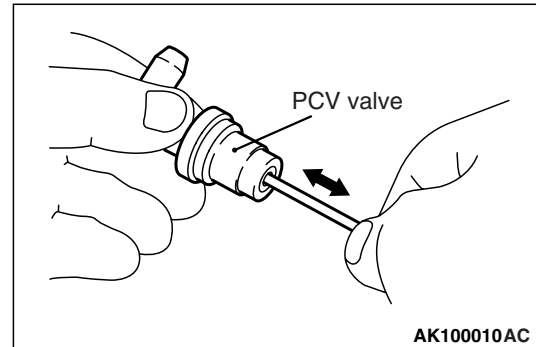

1. Insert a thin rod into the PCV valve from the side shown in the illustration (rocker cover installation side), and move the rod back and forth to check that the plunger moves.
2. If the plunger does not move, there is a clogging in the PCV valve. In this case, clean or replace the PCV valve.

EVAPORATIVE EMISSION CONTROL SYSTEM

GENERAL INFORMATION (EVAPORATIVE EMISSION CONTROL SYSTEM)

M1173005100405

The evaporative emission control system prevents fuel vapours generated in the fuel tank from escaping into the atmosphere.

Fuel vapours from the fuel tank flow through the fuel tank pressure control valve and vapour pipe/hose to be stored temporarily in the canister.

When driving the vehicle, fuel vapours stored in the canister flow through the purge solenoid and purge port and go into the intake manifold to be sent to the combustion chamber.

When the engine coolant temperature is low or when the intake air quantity is small (when the engine is at idle, for example), the engine control unit turns the purge solenoid off to shut off the fuel vapour flow to the intake manifold.

This does not only insure the driveability when the engine is cold or running under low load but also stabilize the emission level.

SYSTEM DIAGRAM

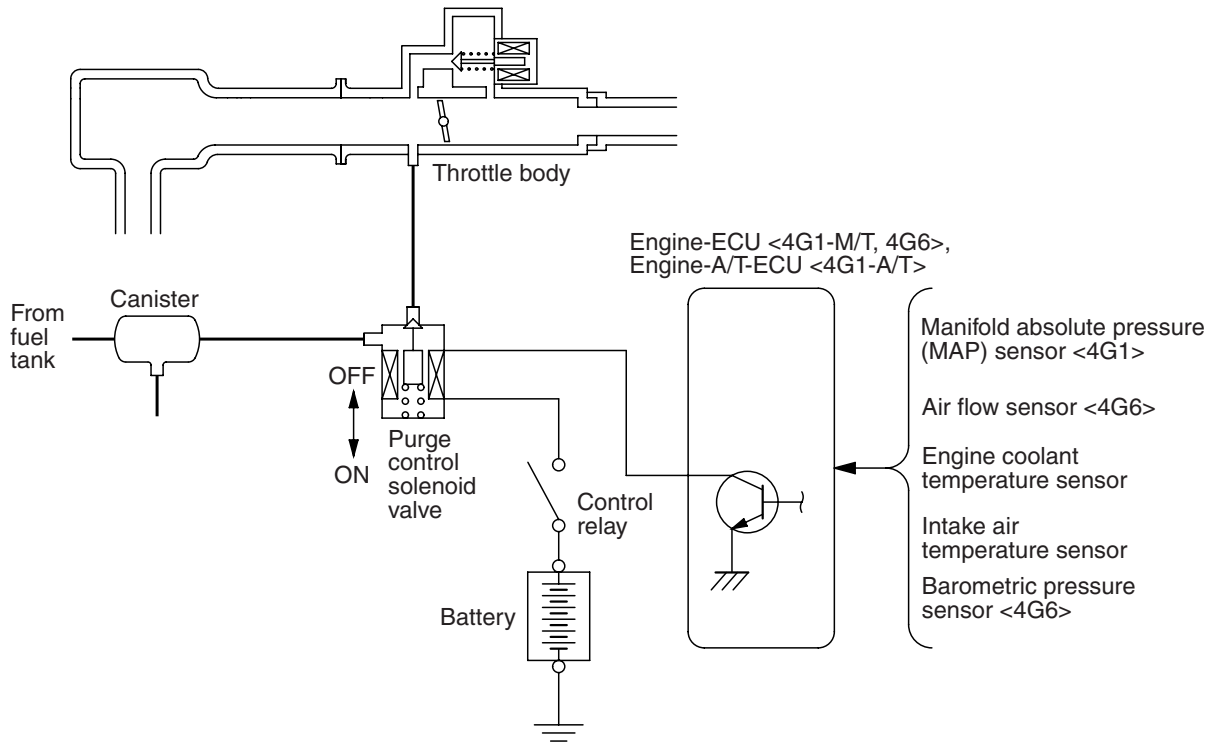

AK204367AC

COMPONENT LOCATION (EVAPORATIVE EMISSION CONTROL SYSTEM)

PURGE CONTROL SYSTEM CHECK

M1173001400299

M1173007500216

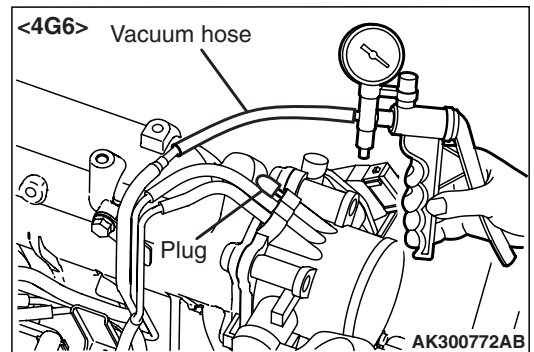
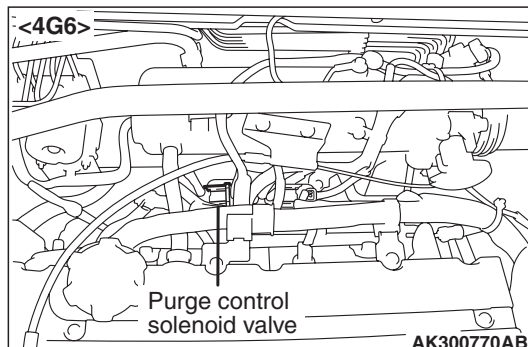
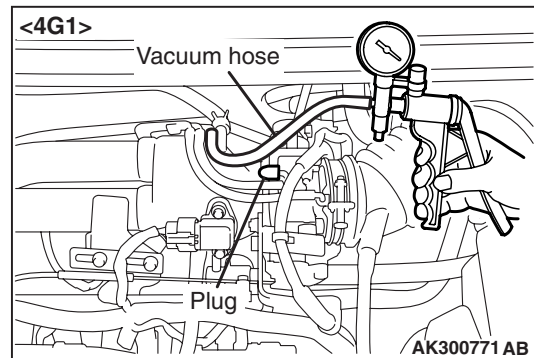
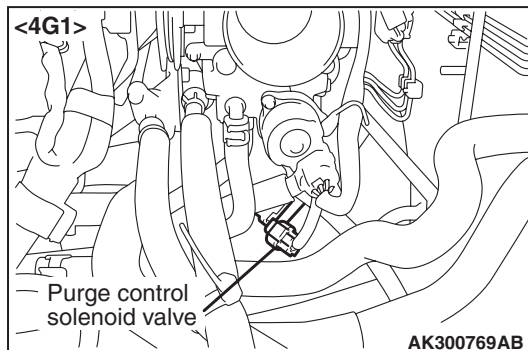

1. Disconnect the vacuum hose (red stripe) from throttle body and connect it to a hand vacuum pump.

2. Plug the nipple from which the vacuum hose was removed.
3. When the engine is cold or hot, apply a vacuum of 53 kPa, and check the condition of the vacuum.

When engine is cold
(Engine coolant temperature: 40° C or less)

Engine condition	Normal condition
At idle	Vacuum is maintained.
3,000 r/min	

When engine is hot
(Engine coolant temperature: 80° C or higher)

Engine condition	Normal condition
At idle	Vacuum is maintained.
3,000 r/min (within 3 minutes after engine starts)	Vacuum will leak.

PURGE PORT VACUUM CHECK

M1173001500177

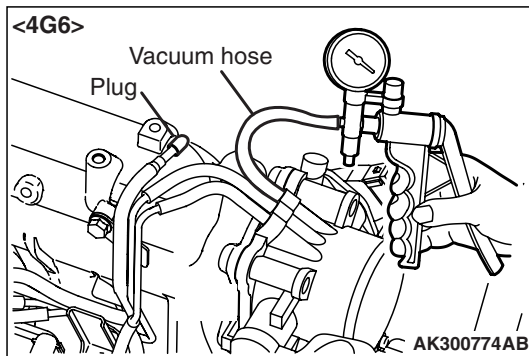
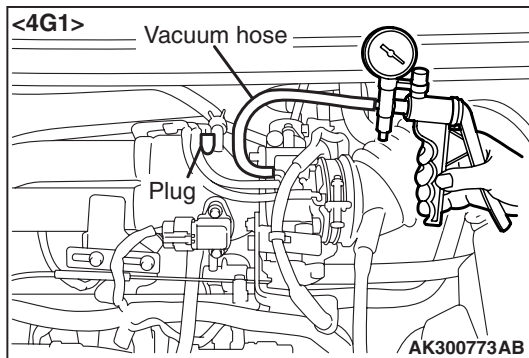

1. Disconnect the vacuum hose (red stripe) from the throttle body and connect a hand vacuum pump to the nipple.
2. Plug the vacuum hose (red stripe).

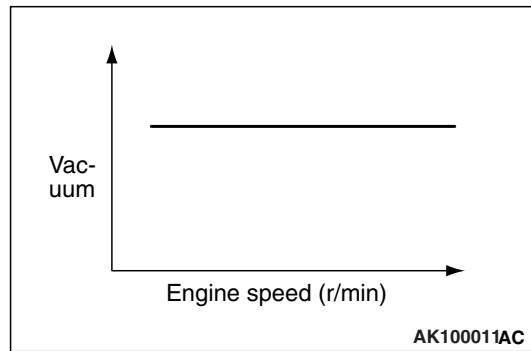

3. Start the engine.
4. Check that a fairly constant negative pressure is generated regardless of the engine speed.
5. If no negative pressure is generated, the port is probably blocked and should be cleaned.

PURGE CONTROL SOLENOID VALVE CHECK

M1173001700193

NOTE: When disconnecting the vacuum hose, always make a mark so that it can be reconnected at original position.

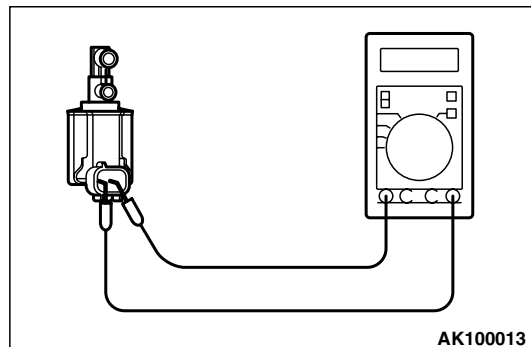
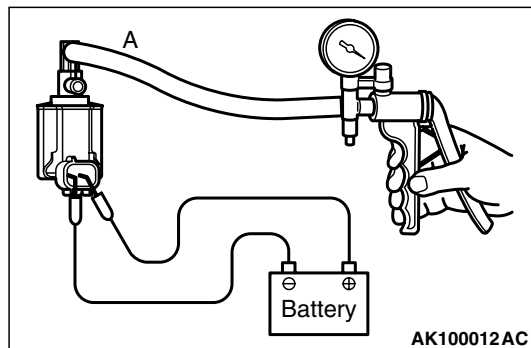

1. Disconnect the vacuum hose from the solenoid valve.
2. Disconnect the harness connector.
3. Connect a hand vacuum pump to nipple (A) of the solenoid valve (refer to the illustration at left).

4. Check airtightness by applying a vacuum with voltage applied directly from the battery to the purge control solenoid valve and without applying voltage.

Battery voltage	Normal condition
Applied	Vacuum leaks
Not applied	Vacuum maintained

5. Measure the resistance between the terminals of the solenoid valve.

Standard value: 30 – 34 Ω (at 20° C)

FUEL VAPOUR CANISTER REMOVAL AND INSTALLATION

M1173004200153

Pre-removal and Post-installation Operation

Air Cleaner Assembly Removal and Installation (Refer to GROUP 15 P.15-3).

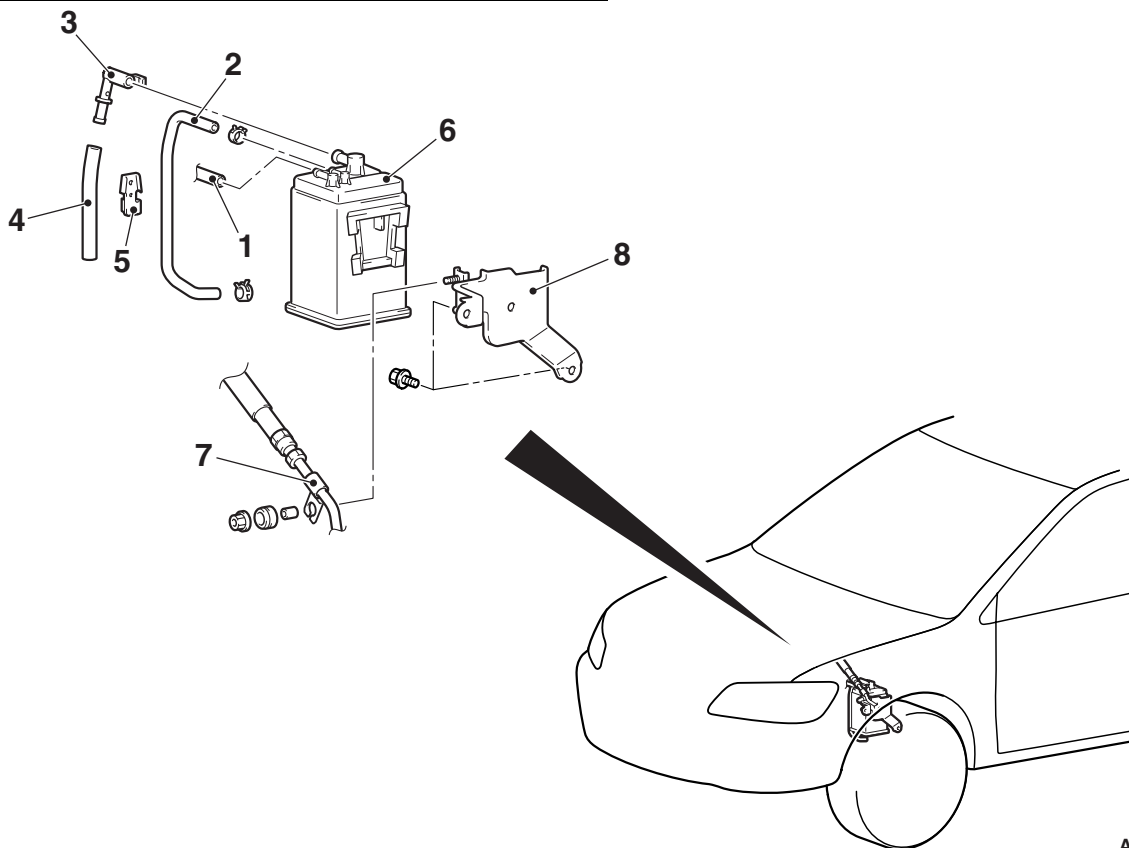

AC208253AD

Removal steps

1. Emission vacuum hose connection
2. Fuel vapour control line hose
3. Fuel vapour control check valve
4. Fuel vapour control line hose

Removal steps (Continued)

5. Fuel vapour control line clamp
6. Fuel vapour canister
7. Fuel high-pressure hose clamp
8. Fuel vapour canister bracket

EXHAUST GAS RECIRCULATION (EGR) SYSTEM

GENERAL INFORMATION (EGR SYSTEM)

M1173005200327

The exhaust gas recirculation (EGR) system lowers the nitrogen oxide (NOx) emission level. When the air/fuel mixture combustion temperature is high, a large quantity of nitrogen oxides (NOx) is generated in the combustion chamber. Therefore, this system recirculates part of emission gas from the exhaust port of the cylinder head to the combustion chamber through the intake manifold to decrease the air/fuel mixture combustion temperature, resulting in reduction of NOx. The EGR flow rate is controlled by the EGR valve so as not to decrease the driveability.

SYSTEM DIAGRAM

<4G1>

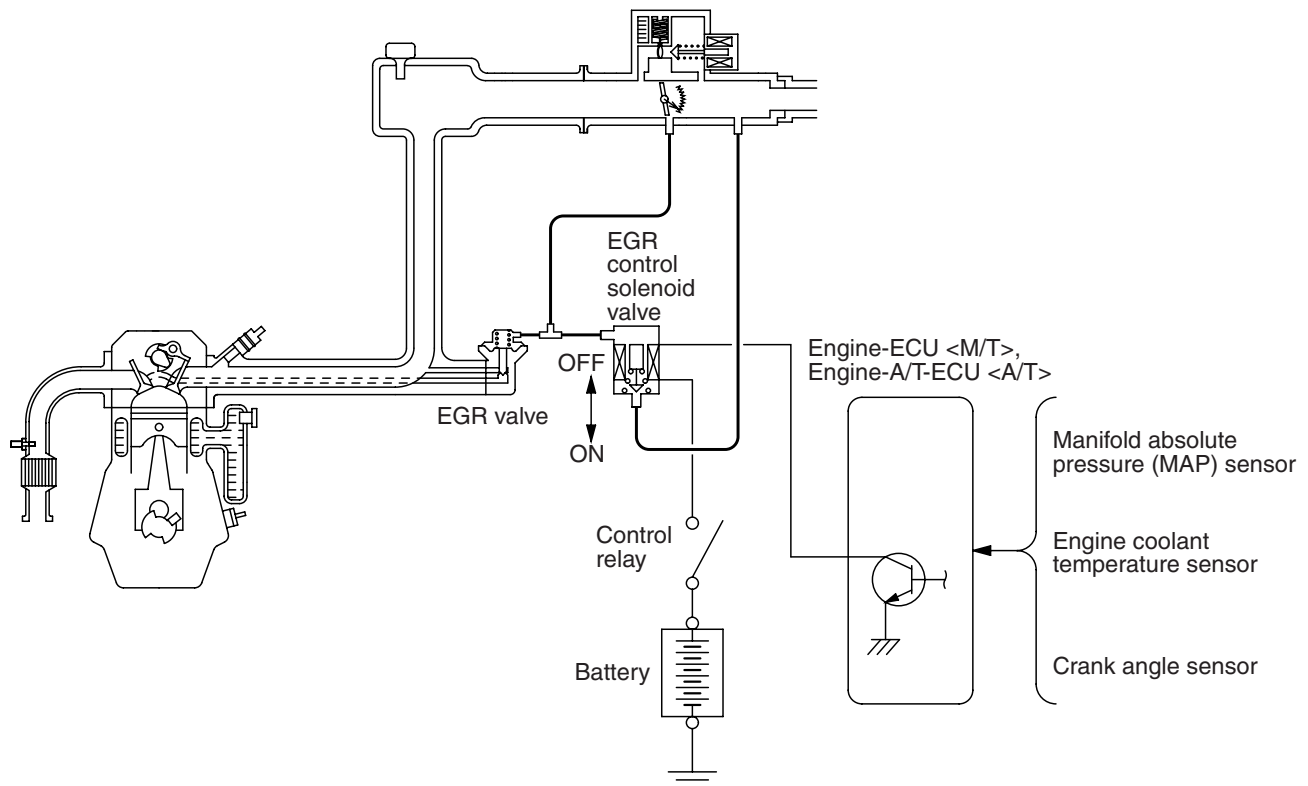

OPERATION

The EGR valve is being closed and does not recirculate exhaust gases under one of the following conditions.

Otherwise, the EGR valve is opened and recirculates exhaust gases.

- The engine coolant temperature is low.
- The engine is at idle.
- The throttle valve is widely opened.

<4G6>

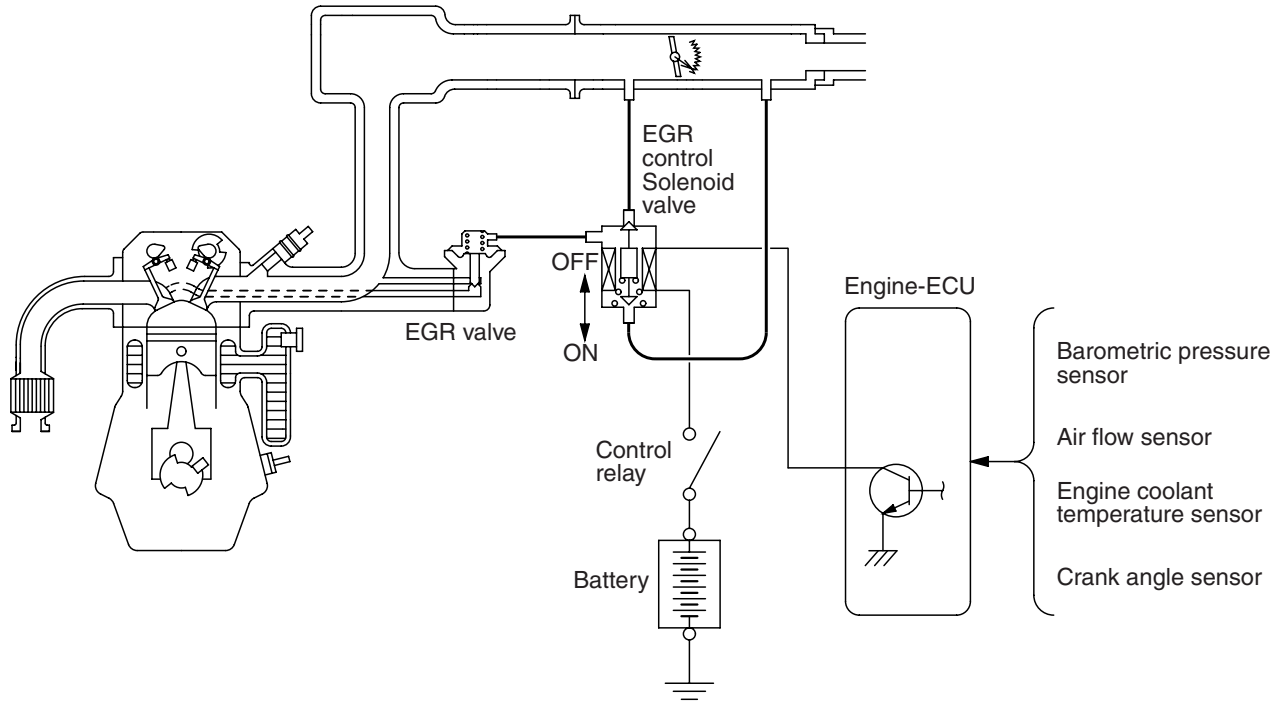

AK302349AB

COMPONENT LOCATION (EGR SYSTEM)

M1173007600224

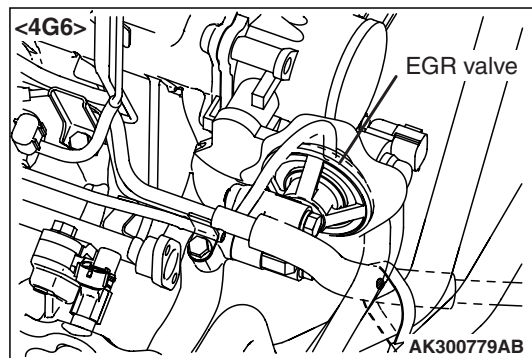
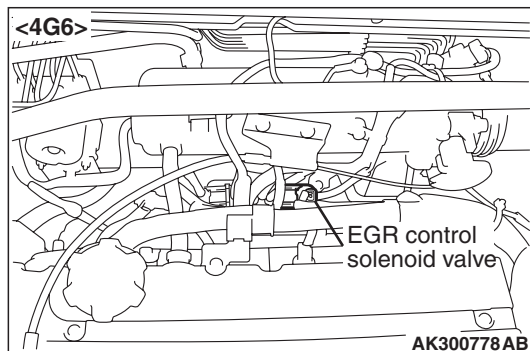
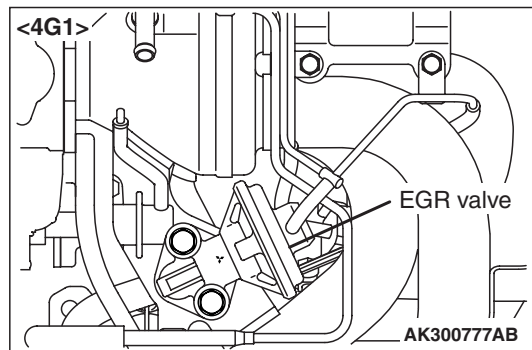
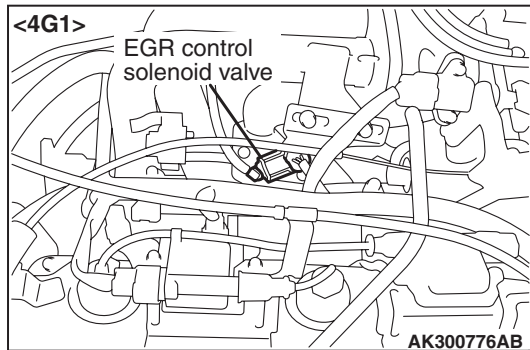

EGR SYSTEM CHECK

M1173002600348

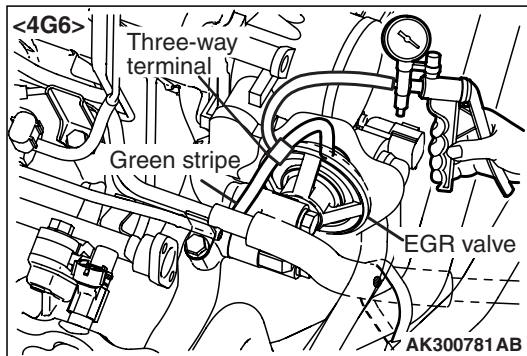
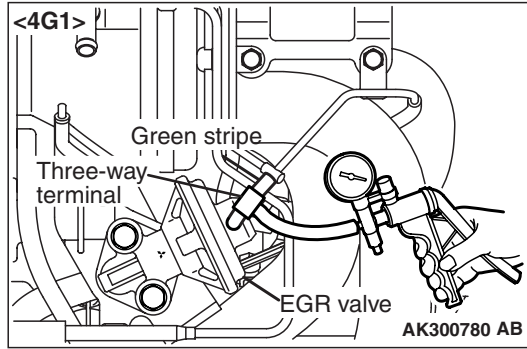

1. Disconnect the vacuum hose (Green stripe) from the EGR valve, and then connect a hand vacuum pump via the three-way terminal.
2. When the engine is hot or cold, check the condition of vacuum by racing the engine.

When engine is cold

(Engine coolant temperature: 20° C or less)

Throttle valve	Normal vacuum condition
Open quickly	No vacuum will generate (the same as barometric pressure.)

When engine is hot

(Engine coolant temperature: 80° C or higher)

Throttle valve	Normal vacuum condition
Open quickly	It will momentarily rise over 13 kPa

3. Disconnect the three-way terminal.

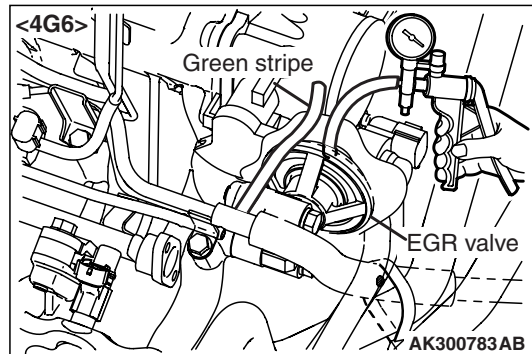
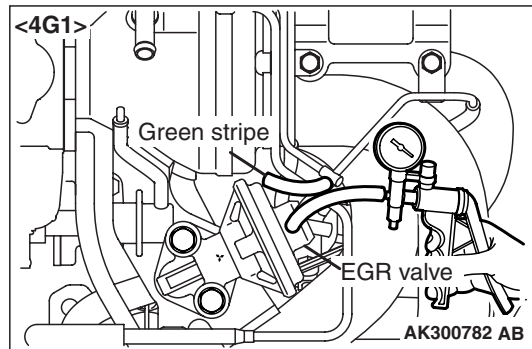

4. Connect the hand vacuum pump to the EGR valve nipple.
5. Check whether the engine stalls or the idling is unstable when a vacuum of 30 kPa or higher is applied during idling.

EGR VALVE CHECK

M1173002800223

1. Remove the EGR valve and inspect for sticking, carbon deposits, etc. If found, clean with a suitable solvent so that the valve seats correctly.
2. Connect a hand vacuum pump to the EGR valve.
3. Apply 67 kPa of vacuum, and check that the vacuum is maintained.

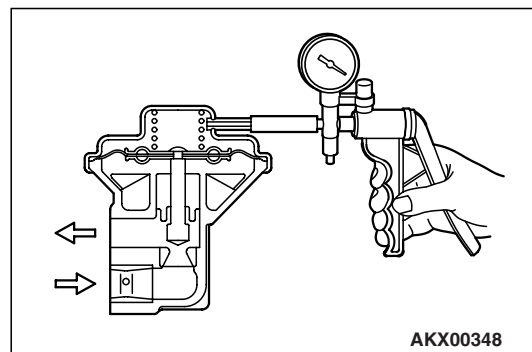

4. Apply a vacuum and check the passage of air by blowing through one side of the EGR passage.

Vacuum	Passage of air
5.3 kPa or less	Air is not blown out
27 kPa or more	Air is blown out

- Replace the gasket, and tighten to the specified torque.

Tightening torque:

- <4G1> $21 \pm 4 \text{ N} \cdot \text{m}$
- <4G6> $20 \pm 2 \text{ N} \cdot \text{m}$

EGR PORT VACUUM CHECK <4G1>

M1173002900167

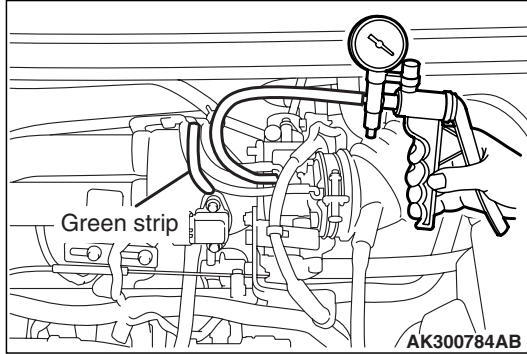

- Disconnect the vacuum hose (Green stripe) from the throttle body EGR vacuum nipple and connect a hand vacuum pump to the nipple.
- Plug the vacuum hose (Green stripe).

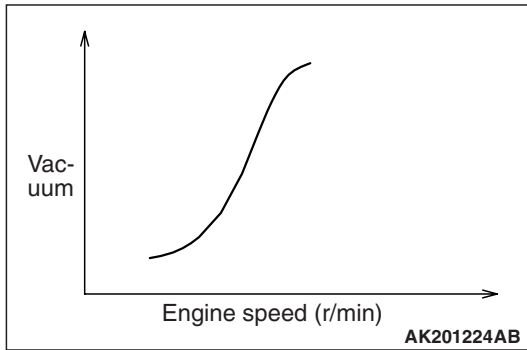

- Start the engine and check that, after raising the engine speed by racing the engine, purge vacuum raises according to engine speed.

NOTE: If there is a problem with change in vacuum, the throttle body purge port may be clogged and require cleaning.

EGR PORT VACUUM CHECK <4G6>

M1173002900156

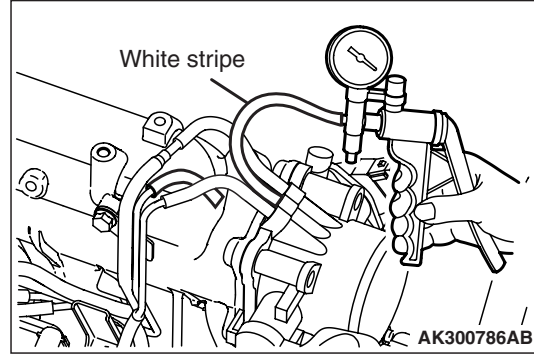

- Disconnect the vacuum hose (White stripe) from the throttle body EGR vacuum nipple and connect a hand vacuum pump to the nipple.
- Plug the vacuum hose (White stripe).

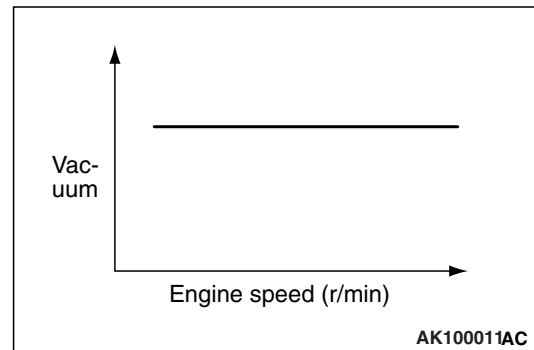

- Start the engine.
- Check that a fairly constant negative is generated regardless of the engine speed.
- If no negative pressure is generated, the port is probably blocked and should be cleaned.

EGR CONTROL SOLENOID VALVE CHECK <4G1>

M1173003100238

NOTE: When disconnecting the vacuum hose, always make a mark so that it can be reconnected at original position.

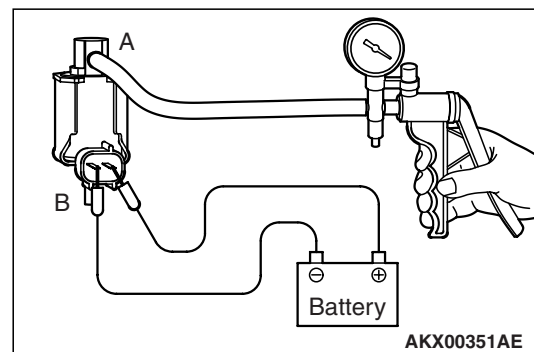

- Disconnect the vacuum hose from the solenoid valve.

2. Disconnect the harness connector.
3. Connect a hand vacuum pump to nipple (A) of the solenoid valve (refer to the illustration at left).
4. Check air tightness by applying a vacuum with voltage applied directly from the battery to the EGR control solenoid valve and without applying voltage.

Battery voltage	Normal condition
Applied	Vacuum leaks
Not applied	Vacuum maintained

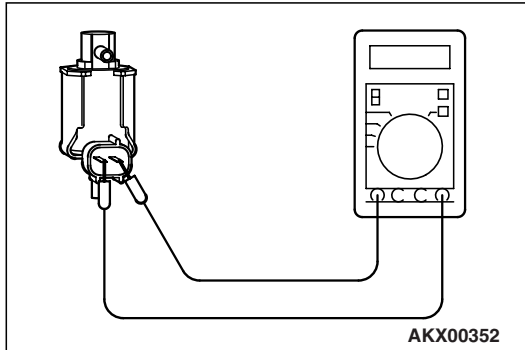

5. Measure the resistance between the terminals of the solenoid valve.

Standard value: 29 – 35 Ω (at 20° C)

EGR CONTROL SOLENOID VALVE CHECK <4G6>

M1173003100249

NOTE: When disconnecting the vacuum hose, always make a mark so that it can be reconnected at original position.

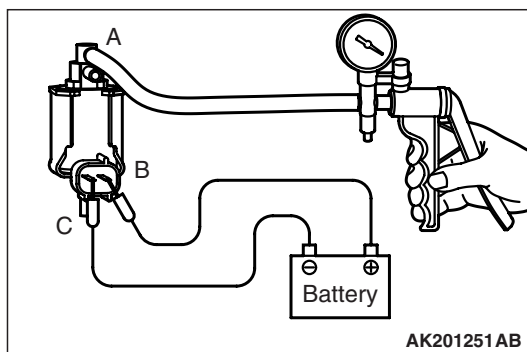

1. Disconnect the vacuum hose from the solenoid valve.

2. Disconnect the harness connector.
3. Connect a hand vacuum pump to nipple (A) of the solenoid valve (refer to the illustration at left).
4. Check air tightness by applying a vacuum with voltage applied directly from the battery to the EGR control solenoid valve and without applying voltage.

Battery voltage	B nipple condition	Normal condition
Not applied	Open	Vacuum maintained
Applied	Open	Vacuum leaks
	Closed	Vacuum maintained

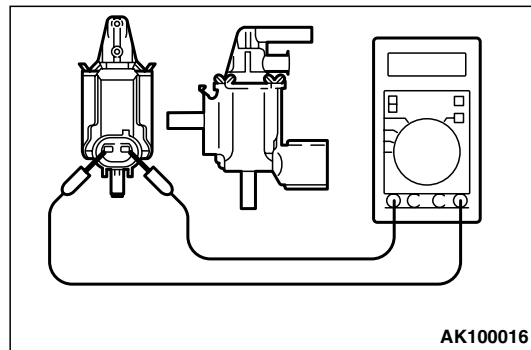

5. Measure the resistance between the terminals of the solenoid valve.

Standard value: 29 – 35 Ω (at 20° C)

EXHAUST GAS RECIRCULATION (EGR)
VALVE REMOVAL AND INSTALLATION

M1173010500175

Pre-removal and Post-installation Operation

Air Cleaner Assembly Removal and Installation (Refer to GROUP 15 P.15-3).

<4G1>

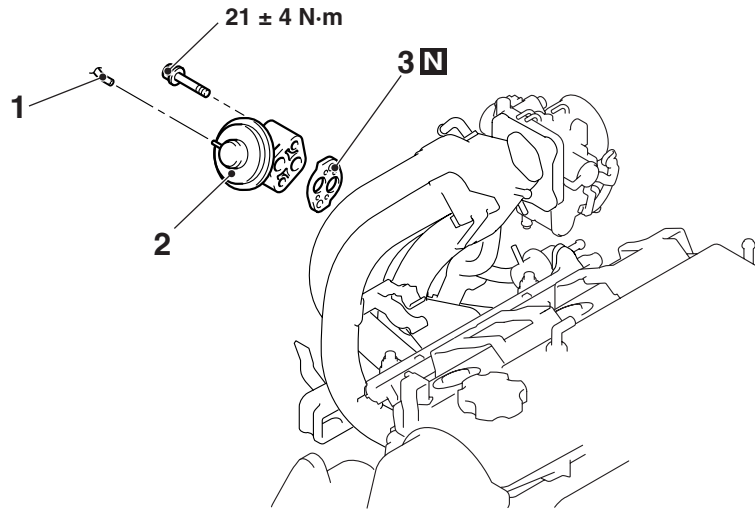

AC208130AC

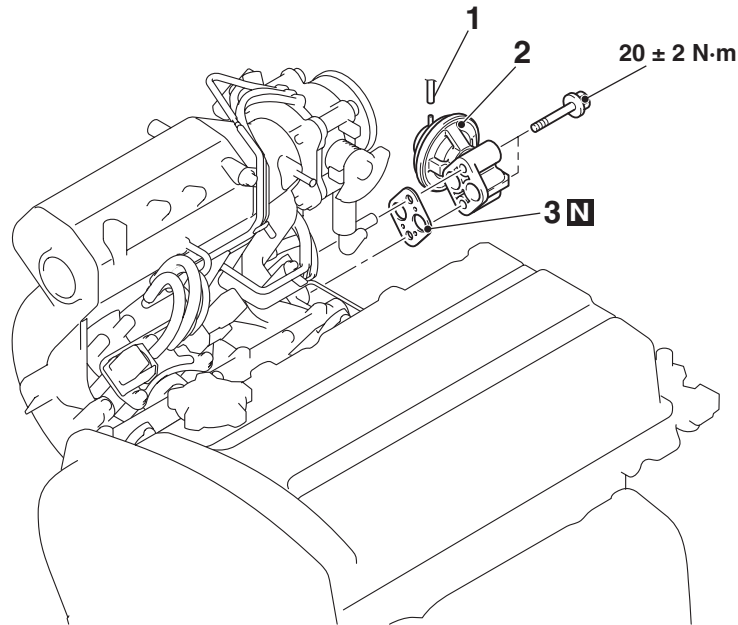

AC301219AB

Removal steps

1. Emission vacuum hose connection

Removal steps (Continued)

2. EGR valve
3. EGR valve gasket

CATALYTIC CONVERTER

REMOVAL AND INSTALLATION <4G1, 4G6-M/T>

M1173003900773

Refer to GROUP 15 - Exhaust Pipe and Main Muffler P.15-11.

REMOVAL AND INSTALLATION <4G6-A/T>

M1173003900784

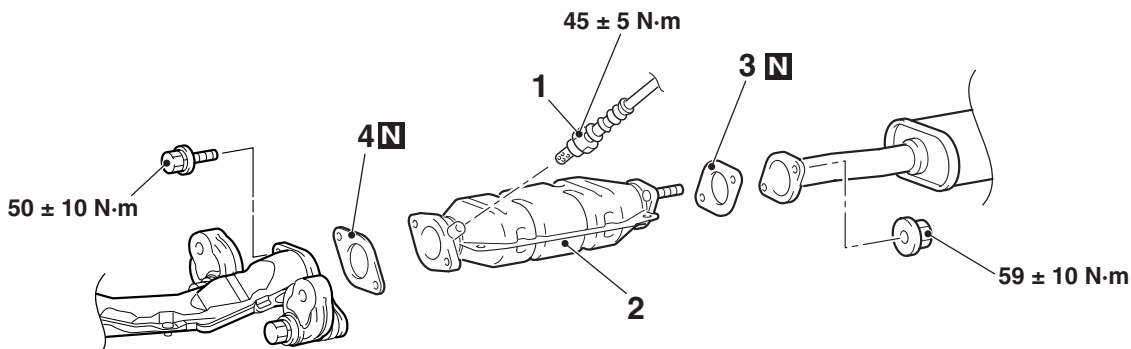

AC504823AB

- <<A>> >>A<<
- Removal steps**
1. Oxygen sensor
 2. Catalytic converter
 3. Gasket
 4. Gasket

INSTALLATION SERVICE POINT >>A<< OXYGEN SENSOR INSTALLATION

REMOVAL SERVICE POINT <<A>> OXYGEN SENSOR REMOVAL

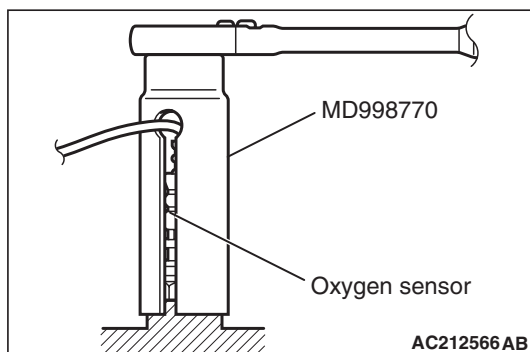

Use special tool oxygen sensor wrench (MD998770) to remove the oxygen sensor.

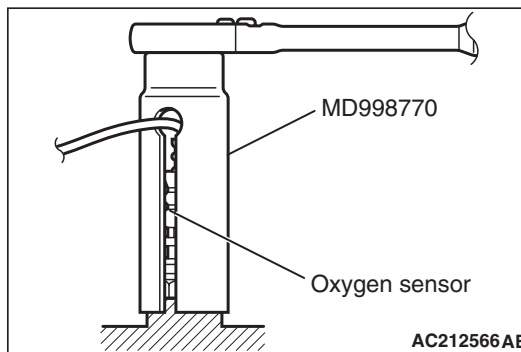

Use special tool oxygen sensor wrench (MD998770) to install the oxygen sensor.

NOTES