

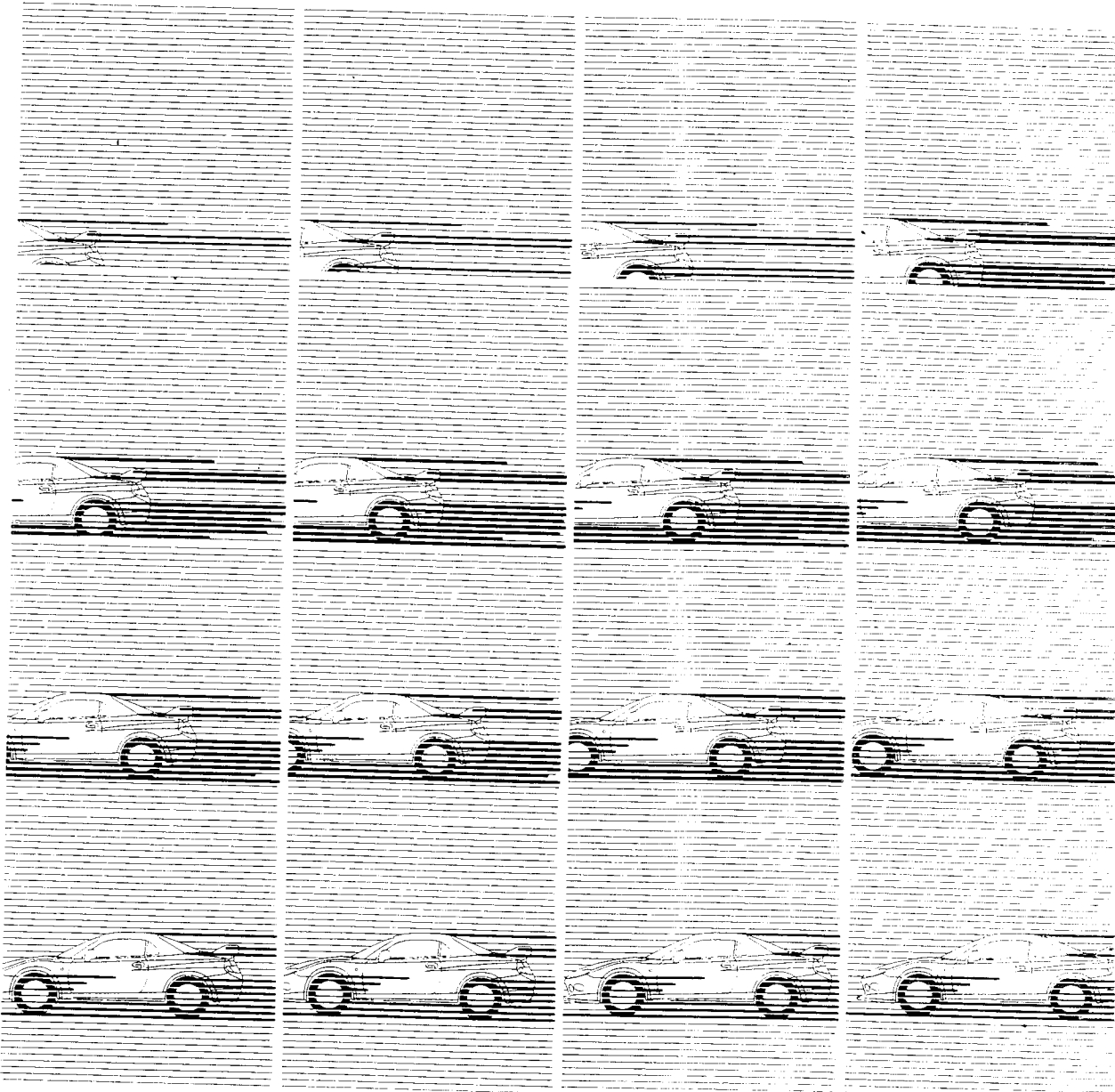

CONFIDENTIAL

# Technical Information Manual

## FTO '98



Pub. No. PYME9801

# FTO

## TECHNICAL INFORMATION MANUAL

### FOREWORD

This manual has been prepared as an introduction to the specifications, features, construction, functions, etc. of the newly developed FTO.

Please read this manual carefully so that it will be of assistance for your service and sales activities.

Please note that the following service manuals are also available and should be used in conjunction with this manual.

#### WORKSHOP MANUAL

ENGINE GROUP	PWEE9801
CHASSIS GROUP	PWME9801
ELECTRICAL WIRING	PHME9801
BODY REPAIR MANUAL	PBME9801
PARTS CATALOGUE	B806G208A□

All information, illustrations and product descriptions contained in this manual are current as at the time of publication. We, however, reserve the right to make changes at any time without prior notice or obligation.



### GROUP INDEX

GENERAL .....	0
ENGINE .....	1
POWER TRAIN .....	2
DRIVE-CONTROL COMPONENTS .....	3
BODY .....	4
EXTERIOR .....	5
INTERIOR .....	6
EQUIPMENT .....	7



---

# GENERAL

## CONTENTS

<b>HOW TO USE THIS MANUAL</b> .....	2	Passive Safety .....	8
Model Indications .....	2	Incorporation of Comforts .....	9
<b>TARGETS OF DEVELOPMENT</b> .....	2	Environmental Protection .....	9
<b>COMMODITY FEATURES</b> .....	2	Serviceability and Reliability .....	9
<b>TECHNICAL FEATURES</b> .....	3	<b>VEHICLE IDENTIFICATION</b> .....	10
Exterior .....	3	Models .....	10
Interior .....	4	Model Code .....	10
Outstanding Basic Performance .....	5	<b>MAJOR SPECIFICATIONS</b> .....	11

---

## HOW TO USE THIS MANUAL

### MODEL INDICATIONS

The following abbreviations are used in this manual for classification of model types.

M/T: Indicates the manual transmission, or models equipped with the manual transmission.

A/T: Indicates the automatic transmission, or models equipped with the automatic transmission.

A/C: Indicates the air conditioner.

### TARGETS OF DEVELOPMENT

The FTO is a two-door specialty vehicle developed as a characteristic and recognizable vehicle that

lays importance on the rider's individuality. Both a sporty style and performance are incorporated.

### COMMODITY FEATURES

#### Sporty characteristic design

- Sharp and aggressive style that expresses the pleasure of driving
- Interior with a feel of performance to enhance the performance felt

#### Light yet sporty state-of-the-art driving

- Smooth quality of the V6 engine
- Direct feel brought by the newly developed M/T and INVECS II sport mode 5A/T
- Linear controllability provided by highly rigid body and completed suspension
- Sport sound muffler creating the right amount of tension

#### Consideration to safety and environmental problems

- SRS air bags provided on driver's side and front passenger's side
- ABS and TCL setting
- High-mount stop lamp mounted
- Power windows with safety mechanism mounted
- New refrigerant air-conditioning system incorporated
- Material names indicated on resin parts

# TECHNICAL FEATURES

## EXTERIOR

“Sharp and aggressive” style that expresses the pleasure of driving through it’s compact strength and lively form

- (1) Clean-cut sports car proportion through the wide vehicle width and shortened total length
- (2) Sporty silhouette through strong wedge form and high belt line

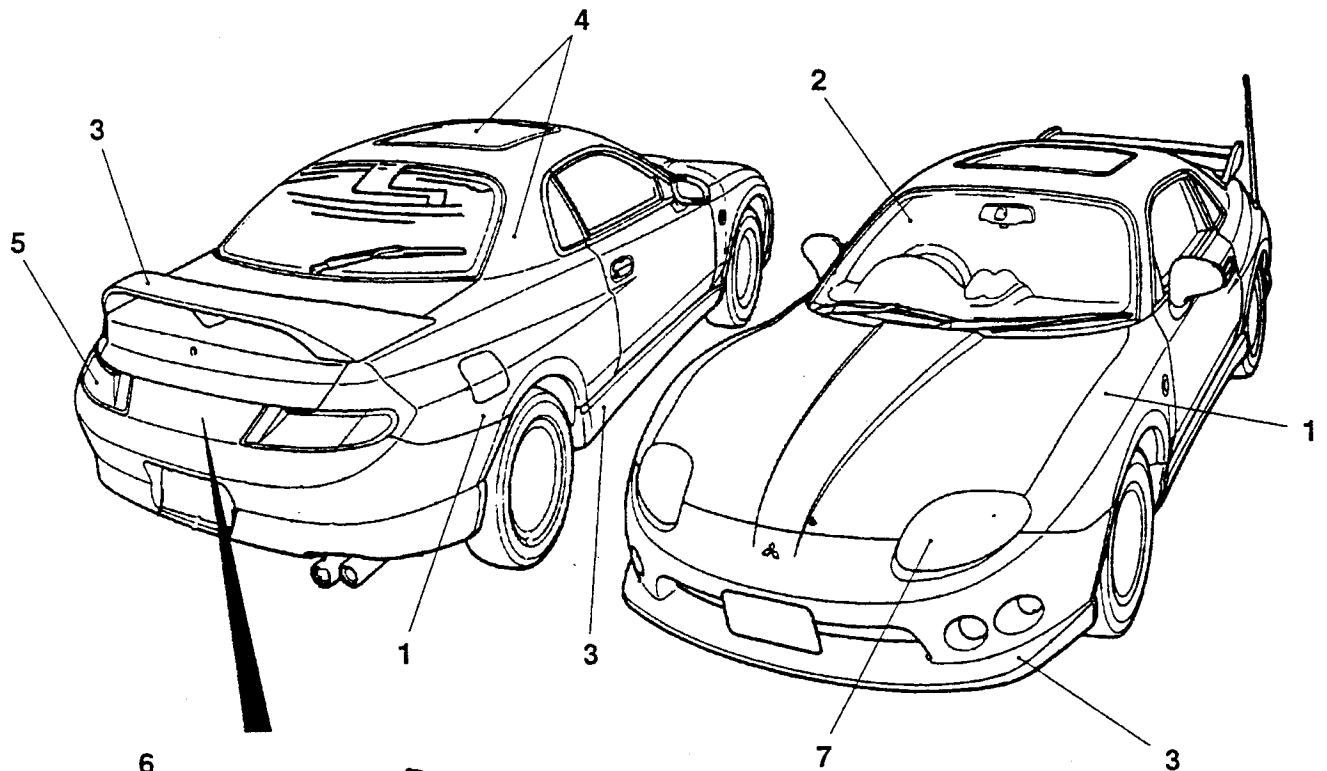

**FTO**

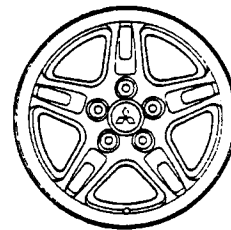

00R0005

00008477

No.	Features
1	Road hugging style with front and rear fenders that are slimmed to the front and back yet powerfully project outward
2	Rounded windshield with large and outstanding aerodynamic properties
3	Aero parts that emphasis the low center of gravity image
4	Sporty cabin accented by powerful rear pillar and roof accent bead
5	Characteristic rear end with simple rear combinations lamps on sharply cutoff surface
6	FTO logo emphasizing sporty feel and brand image with strong moving expression
7	Exterior part design pursuing high-performance image for headlamps and aluminum wheels, etc.

## INTERIOR

“High-performance feel interior” enhancing the performance felt by the rider through a design treatment that pursues a powerful basic form and functional beauty

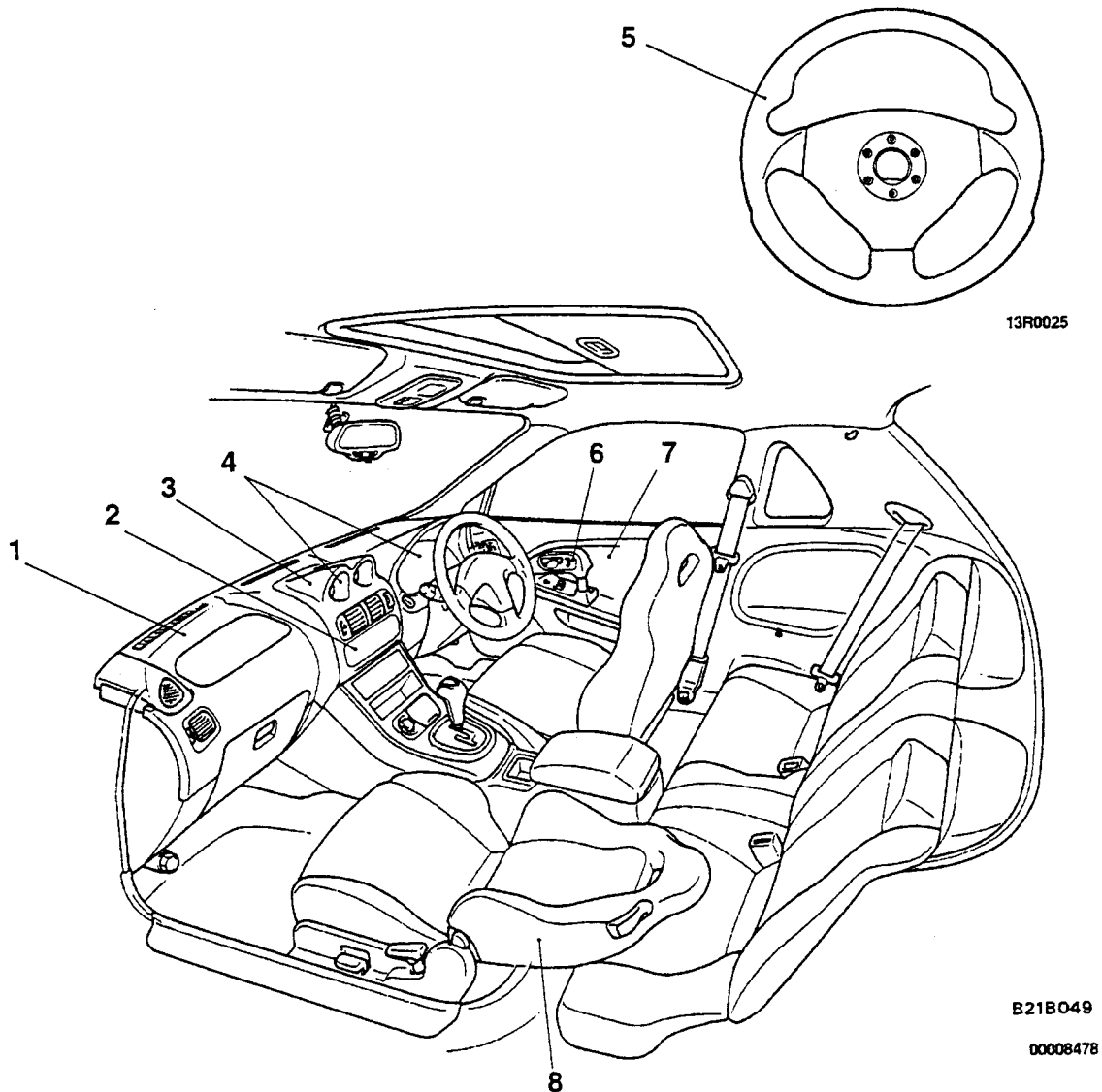

No.	Features
1	Deeply contoured three-dimensional structure instrument panel aimed to prioritize the driver
2	Highly operable switches laid out by function
3	Center console having a feel of continuity with bulge section installed on hood
4	Mechanical design combination meter and sub-meter allowing travel to be predicted (all are needle-indicator types)
5	MOMO leather bound three-spoke steering wheel
6	Sporty design with inside door handle, lock knob and power window switches functionally congregated on door grip handle section
7	Three-dimensional form door trim with plenty of fabric inserts
8	Bucket-type front seats with integrated head rest providing outstanding feel of hold with shape that securely embraces passengers

**OUTSTANDING BASIC PERFORMANCE****ENGINE**

The 6A1 engine mounted in the FTO is basically the same as the 6A12-DOHC-MIVEC engine mounted on the previously marketed 1997

GALANT. A well-balanced output characteristic is exerted in all operation regions with the variable valve mechanism (MIVEC).

**Major Specifications**

Items		6A12-DOHC-MIVEC
Total displacement ml		1,998
Bore x stroke mm		74.4 x 69.0
Compression ratio		10.0
Combustion chamber		Pentroof type
Camshaft arrangement		DOHC
Valve timing Low-speed cam (high-speed cam)	Intake Opening	BTDC 15° (37.5°)
	Intake Closing	ABDC 41° (82.5°)
	Exhaust Opening	BBDC 41° (75°)
	Exhaust Closing	ATDC 15° (30°)
Fuel system		Electronic control multipoint fuel injection
Rocker arm		Roller type
Auto-lash adjuster		Equipped

**TCL (Traction Control System)**

The TCL system (slip control and trace control) has been incorporated as an option, allowing easy driving to be realized.

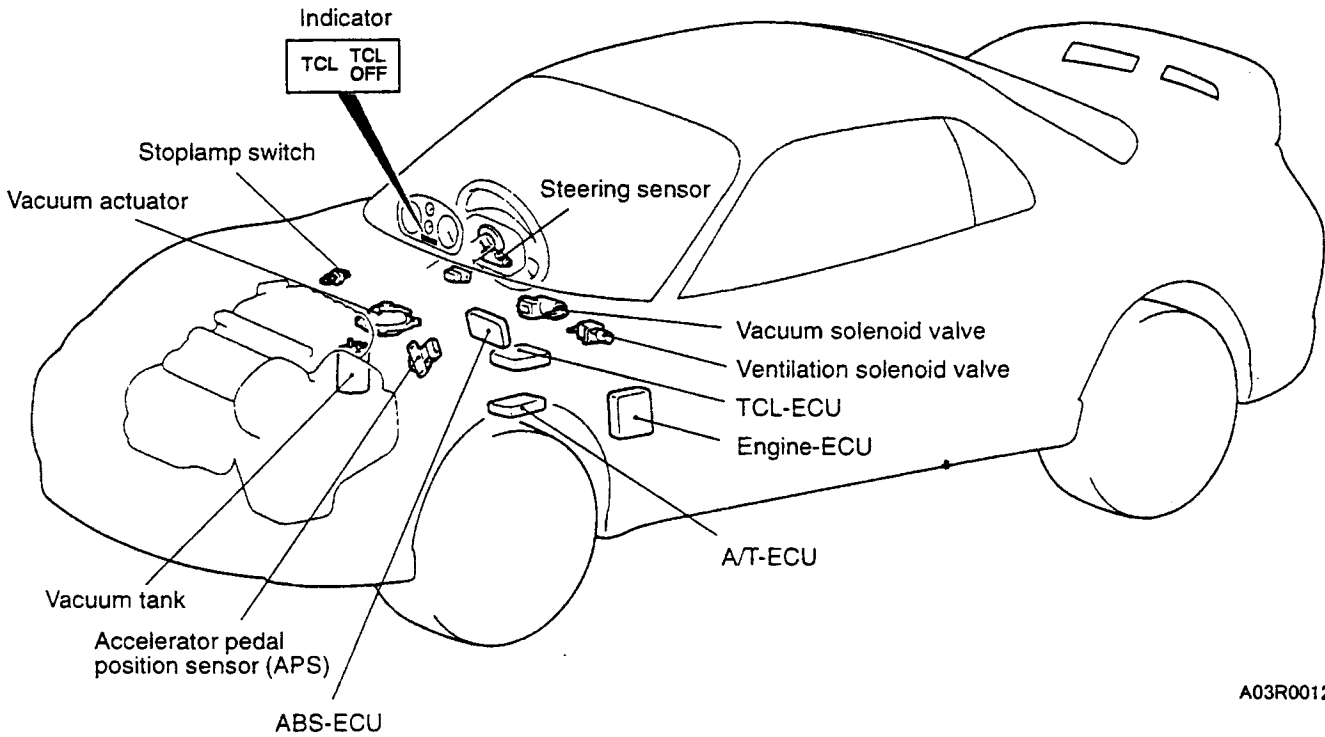

A03R0012

**MANUAL TRANSMISSION, AUTOMATIC TRANSMISSION**

The newly developed F5M42 manual transmission and F5A42 automatic transmission have been incorporated due to changes in the engine mounting direction.

The main features are as follow:

- Improved serviceability through the elimination of need for transmission oil and automatic transmission fluid replacement

- Improved performance and marketability through incorporation of two shafts and detailed changes in transmission mechanism
- Improved marketability through incorporation of ultra-easy drive INVECS II sport mode AT

**SUSPENSION**

McPherson struts have been incorporated for the front suspension. The trailing arm type multi-link

suspension has been incorporated for the rear suspension.

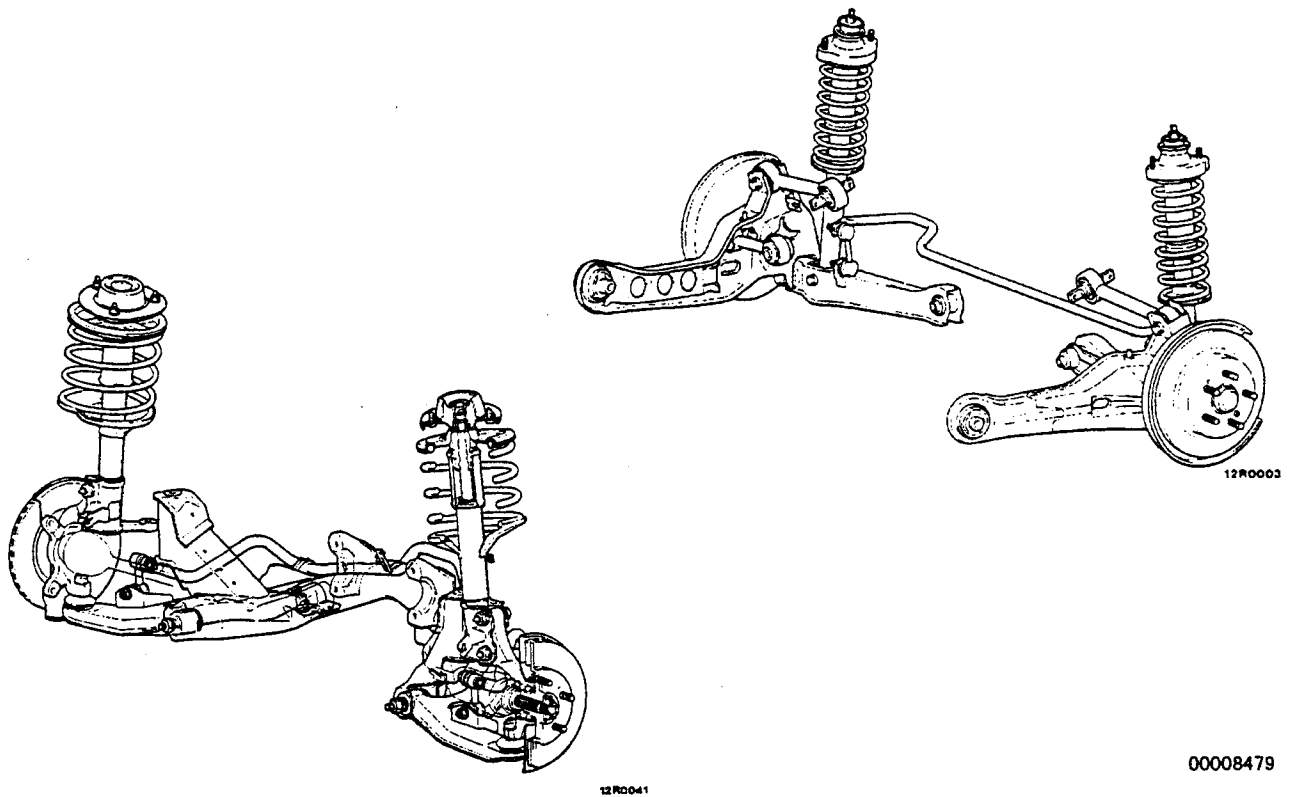
**BRAKE SYSTEM**

- (1) 4-wheel disc brakes have been mounted.
- (2) 15-inch 2-pot type disc brakes have been mounted for the front brakes.
- (3) Compact and lightweight ABS is mounted for all vehicles.
- (4) Due to the mounting of ABS, a 7+8-inch tandem type brake booster has been mounted to improve the brake feeling.

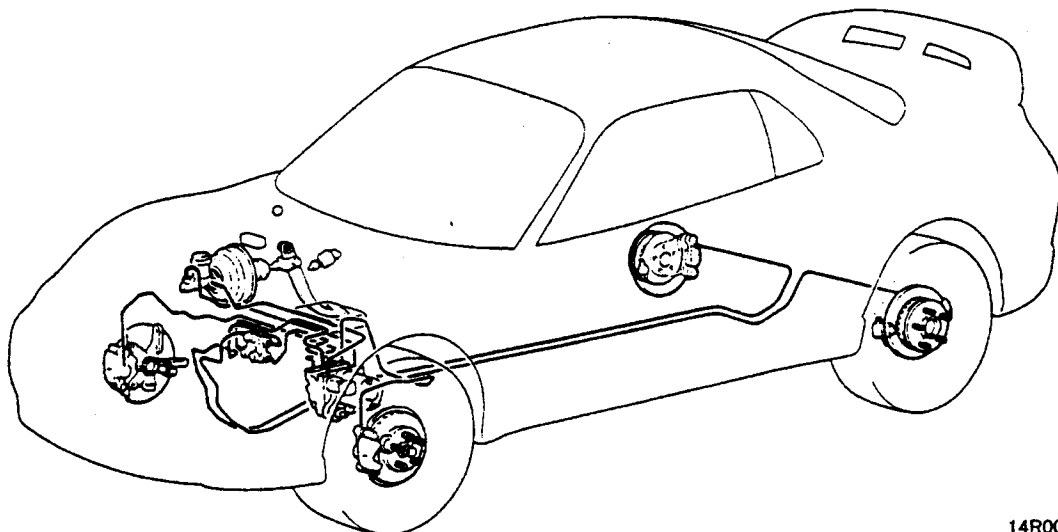

14R0024

**PASSIVE SAFETY**

**SRS AIR BAG**

A driver's side SRS air bag or driver's side + front passenger's side SRS air bags are mounted in all vehicles. The vehicle deceleration rate at the time of collision is detected by an analog G sensor and safing G sensor built-in the SRS air bag control

unit (SRS-ECU). The air bag is expanded by an electrical ignition. The front passenger's side SRS air bag is installed in the top of the instrument panel.

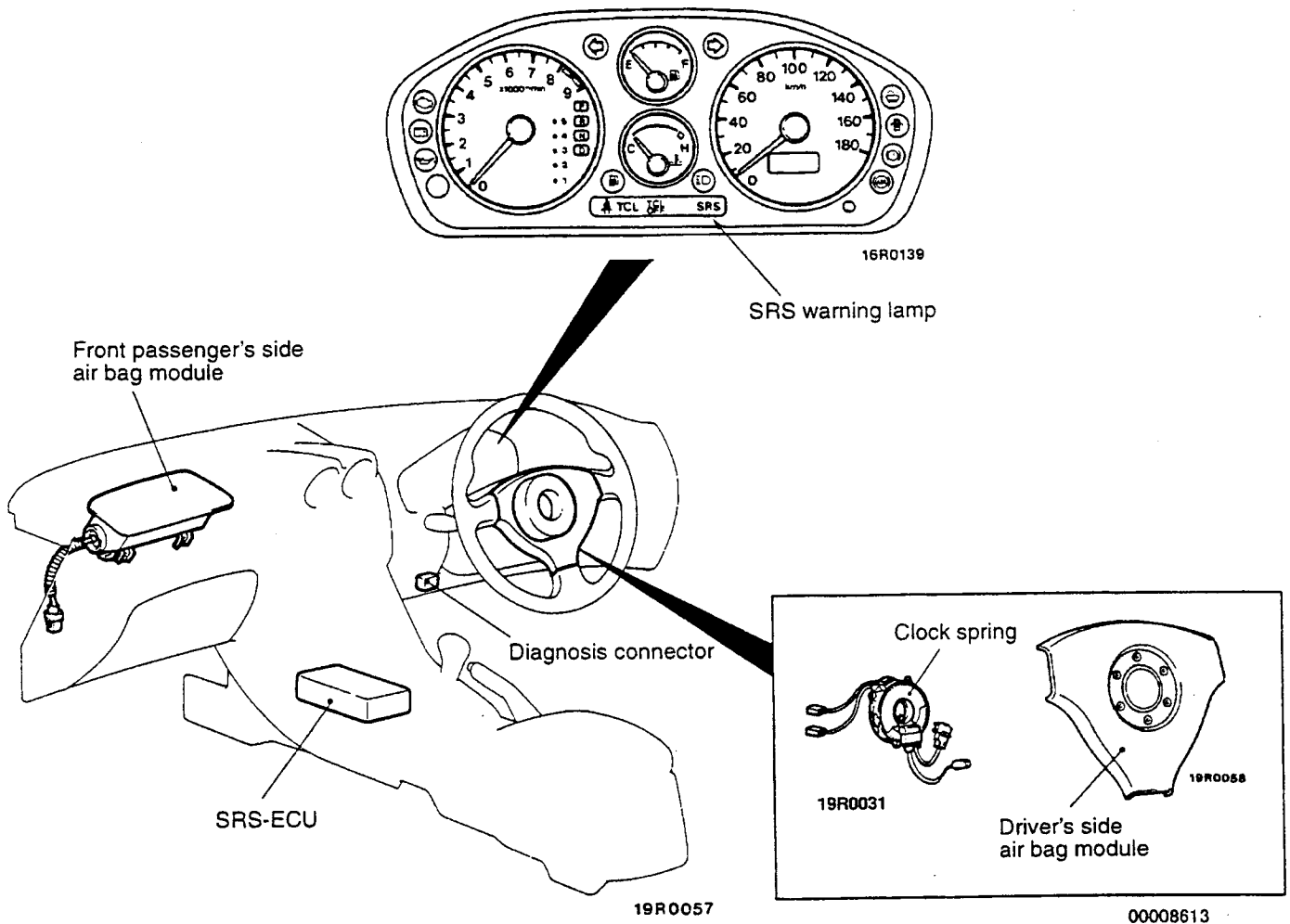

**POWER WINDOWS WITH SAFETY MECHANISM AND MOTORIZED OUTER SLIDING TYPE GLASS SUNROOF WITH SAFETY MECHANISM**

The power windows with safety mechanism reverse the motor run to lower the glass by approx. 110 mm when catching of hands or necks, etc., is sensed while the glass is rising.

The motorized outer sliding type glass sunroof with safety mechanism reverses the motor run to open the glass by approx. 60 mm when catching of hands or necks, etc., is sensed while the glass is closing.



## INCORPORATION OF COMFORTS

Various comfort equipment has been mounted so that the driver as well as passengers can comfortably enjoy long drives.

- (1) Power steering
- (2) Tilt steering
- (3) Centre door lock, keyless entry systems
- (4) Power windows with safety mechanism
- (5) Motorized outer sliding type glass sunroof with safety mechanism

- (6) Motorized remote controlled or motorized stored type remote controller mirrors
- (7) Bucket type front seats with integrated head rest
- (8) Room mirror with built-in map lamp
- (9) Fully automatic air conditioning with new refrigerant

## ENVIRONMENTAL PROTECTION

In response to increasing awareness on resource protection and global environment protection throughout the world, we have aimed to

manufacture a vehicle kind to both humans and the earth.

## HANDLING OF RECYCLING

By indicating the material name on resin parts, recycling has been simplified (instrument panel, floor console, trim, etc.)

## GLOBAL ENVIRONMENT PROTECTION

- (1) Elimination of asbestos in gaskets and pads, etc.
- (2) Elimination of Freon
  - Limitation of Freon use in manufacturing process of seats and steering wheels, etc.

- (3) Reduction of waste through increased durability
  - Incorporation of non-rusting steel plates for outer plates and main members of body
  - Increased long life of brake fluid and cooling water

## SERVICEABILITY AND RELIABILITY

### MAINTENANCE FREE

Elimination of ignition period adjustment through incorporation of crank angle sensor installed directly on crankshaft

## INCORPORATION OF MUT-II AND STRENGTHENED DIAGNOSIS

Serviceability has been improved through the incorporation of MUT-II.

A diagnosis function has been incorporated in the following systems, allowing diagnosis codes and service data to be called out by MUT-II, and the actuator test to be carried out.

- MPI
- TCL
- ELC-5A/T
- ABS
- SRS
- Fully automatic air conditioning

## VEHICLE IDENTIFICATION

## MODELS

Model code		Engine model	Transmission model	Fuel supply system
DE3A	HNGHR	6A12 <V6-MIVEC> (1,998 ml)	F5M42 (2WD – 5M/T)	MPI
	HYGHR		F5A42 (2WD – 5A/T)	

## MODEL CODE

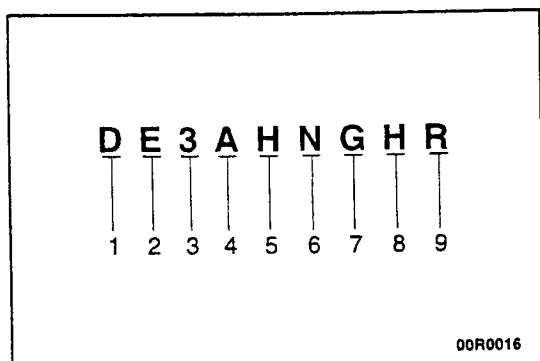

No.	Items	Contents
1	Vehicle line	D: FTO
2	Drive system	E: 2WD
3	Engine system	3: 1,998 ml Petrol engine (6A12 <V6-MIVEC>)
4	Group	A: Passenger car
5	Vehicle form	H: 2 door notchback coupe
6	Transmission type	N: 5-speed manual transmission
		Y: 5-speed automatic transmission
7	Vehicle grade	G: GPX
8	Specified engine feature	H: MPI, DOHC, MIVEC
9	Steering wheel location	R: Right hand

MAJOR SPECIFICATIONS

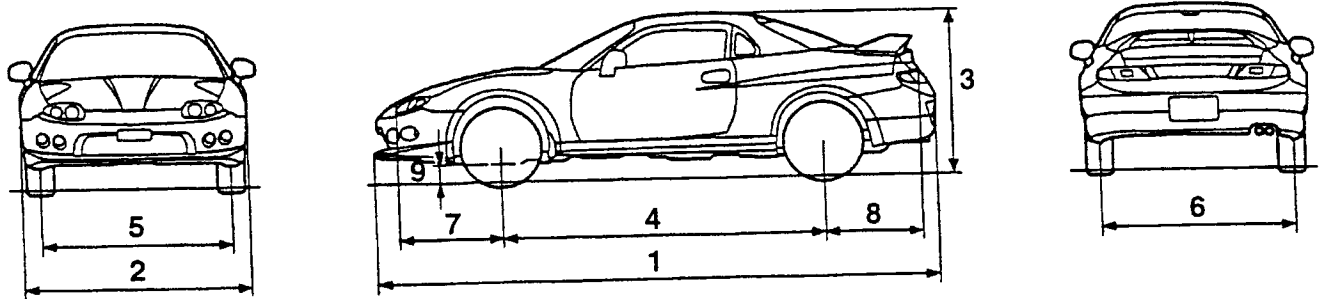

P01A062

Items			DE3AHNGHR	DE3AHYGHR
Vehicle dimensions mm	Overall length	1	4,365	4,365
	Overall width	2	1,735	1,735
	Overall height (unladen)	3	1,300, 1,305*	1,300, 1,305*
	Wheelbase	4	2,500	2,500
	Tread-front	5	1,490	1,490
	Tread-rear	6	1,485	1,485
	Overhang-front	7	800	800
	Overhang-rear	8	795	795
	Ground clearance (unladen)	9	150	150
Vehicle weight kg	Kerb weight		1,200	1,240
	Max. gross vehicle weight rating		1,590	1,590
	Max. axle weight rating-front		930	930
	Max. axle weight rating-rear		660	660
Seating capacity			4	4
Engine	Model No.		6A12	6A12
	Total displacement mℓ		1,998	1,998
Transmission	Model No.		F5M42	F5A42
	Type		5-speed manual	5-speed automatic
Fuel system	Fuel supply system		MPI	MPI

NOTE: \* indicates vehicles equipped with sunroof.

---

# ENGINE

## CONTENTS

<b>GENERAL INFORMATION</b> .....	2	Fan Motor Relay (Radiator fan, A/C condenser Fan) Control .....	9
Major Specifications .....	2	Self-diagnosis System .....	9
<b>COOLING SYSTEM</b> .....	3	<b>EMISSION CONTROL SYSTEM</b> .....	10
<b>INTAKE AND EXHAUST</b> .....	4	<b>MOUNT</b> .....	11
Exhaust Pipe .....	4	<b>TCL</b> .....	12
<b>FUEL SYSTEM</b> .....	5	Construction and Operation .....	15
<b>CONTROL SYSTEM</b> .....	6	1. TCL Control Modes .....	15
Fuel Injection Control .....	7	2. Control System .....	15
Idle Speed Control (ISC) .....	7	3. TCL Control Unit (TCL-ECU) .....	16
Ignition Timing and Distribution Control .....	8	<b>ACCELERATOR SYSTEM</b> .....	19
Power Supply and Fuel Pump Control, Alternator Current Control, Variable Induction Control, Traction Control, and Valve Timing Switching Control .....	8	Accelerator Pedal, Accelerator Cable .....	19

---

## GENERAL INFORMATION

The 6A1 engine mounted in the FTO is basically the same as the 6A12-DOHC-MIVEC engine mounted on the previously marketed 1997

GALANT. A well-balanced output characteristic is exerted in all operation regions with the variable valve mechanism (MIVEC).

## MAJOR SPECIFICATIONS

Items	6A12-DOHC-MIVEC	
Total displacement ml	1,998	
Bore × stroke mm	78.4 × 69.0	
Compression ratio	10.0	
Combustion chamber	Pentroof type	
Camshaft arrangement	DOHC	
Valve timing Low-speed cam (high-speed cam)	Intake Opening	BTDC 15° (37.5°)
	Intake Closing	ABDC 41° (82.5°)
	Exhaust Opening	BBDC 41° (75°)
	Exhaust Closing	ATDC 15° (30°)
Fuel system	Electronic control multipoint fuel injection	
Rocker arm	Roller type	
Auto-lash adjuster	Equipped	

## COOLING SYSTEM

The cooling device incorporates the water-cooled pressure forced circulation method, and has the following features.

- The cooling performance is improved and the weight is reduced through the incorporation of a compact and high performance radiator.
- By arranging the radiator cap on the engine unit, the water replenishment ability is improved.
- An inlet control method with a thermostat arranged on the engine coolant intake side
- from the radiator to the engine has been incorporated, allowing the cooling water temperature fluctuation to be reduced.
- Centralized control by the engine control unit has been incorporated for the cooling fan control, allowing the cooling performance to be improved, as well as noise to be reduced and accelerability to be improved. (Refer to P.1-6.)

### SPECIFICATIONS

Items		Specifications
Engine coolant control system		Inlet control system
Cooling fan	Type	Electric-driven
Water pump	Type	Impeller of centrifugal type
	Drive method	Timing belt
Thermostat	Type	Wax type
	Valve opening temperature °C	82.0
Radiator	Type	Corrugated fin type
A/T oil cooler	Type	Dual pipe type
Radiator fan motor	Maker	DENSO
	Type	Direct flow ferrite type
	Rated load torque Nm	25
	Speed r/min	2,000 ± 250
	Current A	6.0 ± 1.5

### CONSTRUCTION DIAGRAM

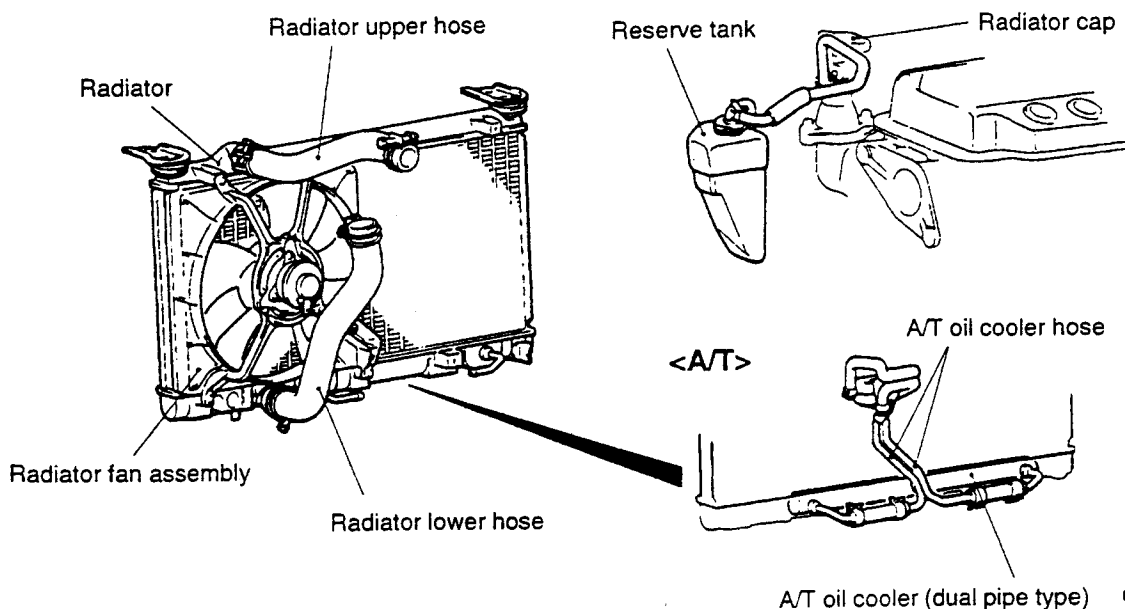

04R0004  
00008481

## INTAKE AND EXHAUST

### EXHAUST PIPE

- A three-way method has been incorporated.
- A sound absorbing large pre-muffler and sub-muffler that reduce the high harmonics exhaust sound have been incorporated.
- Megaphone type molding has been incorporated on the tail pipe to improve the exhaust sound quality.
- A high-corrosion resistant stainless steel main muffler has been incorporated.
- An equal length front pipe that allows reduction of the exhaust noise caused by the exhaust interference of the front bank and rear bank has been incorporated.
- A large bore (diameter 60.5 mm) exhaust pipe has been incorporated from the catalytic converter to the main muffler to improve the engine output.

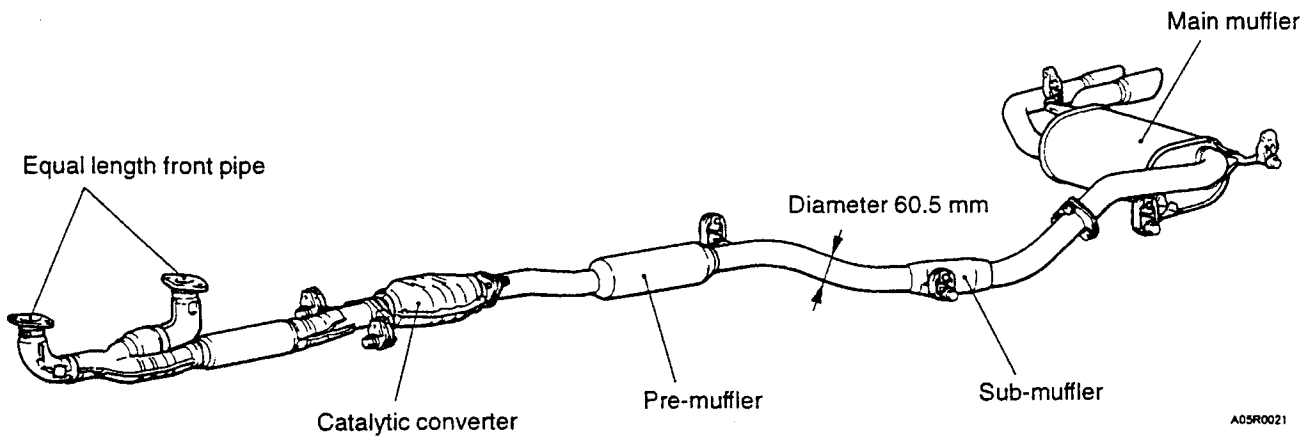

## FUEL SYSTEM

The fuel system is configured of the magnetic type fuel injector, delivery pipe, fuel pressure regulator (control pressure 329 kPa), motorized fuel pump that supplied high-pressure fuel, fuel filter, and fuel tank, etc. This system has the following features:

- A fuel cut-off valve (roll over valve) is mounted to prevent the flow of fuel when the vehicle rolls over.
- A resin screw-in type fuel filler cap is incorporated.
- A service wheel that allows the fuel gauge unit to be mounted and removed without removing the fuel tank is incorporated.
- A fuel pump drive terminal is mounted in the engine room to improve serviceability.
- An MPI system that injects fuel into each cylinder is incorporated for the electronic control fuel injection system.

## SPECIFICATIONS

Items		Specifications
Fuel tank capacity ℓ		60
In tank filter		Provided
Fuel pump type		Electric-driven
Fuel return device		Fuel pressure regulator return
Fuel filter type		Cartridge (filter-paper type)
Injector	Type	Electromagnetic
	Number	6
Throttle position sensor	Type	Variable resistor type (idle position switch incorporated)
	Idle position switch type	Contact switch type
Fuel evaporation gas emission suppression device		Canister type (2-way valve incorporated)

## CONSTRUCTION DIAGRAM

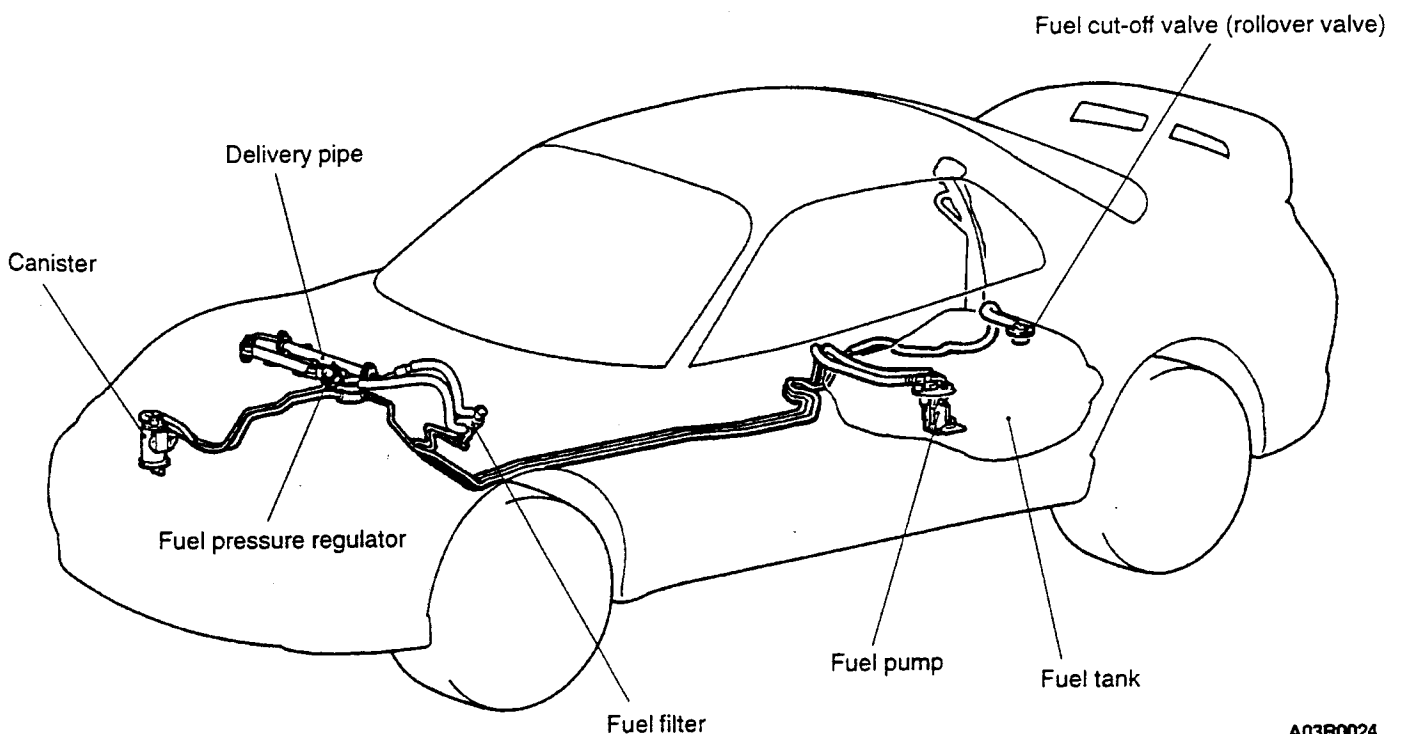



# CONTROL SYSTEM

The control method is basically the same as that for the 6A12-DOHC-MIVEC engine mounted in the GALANT.

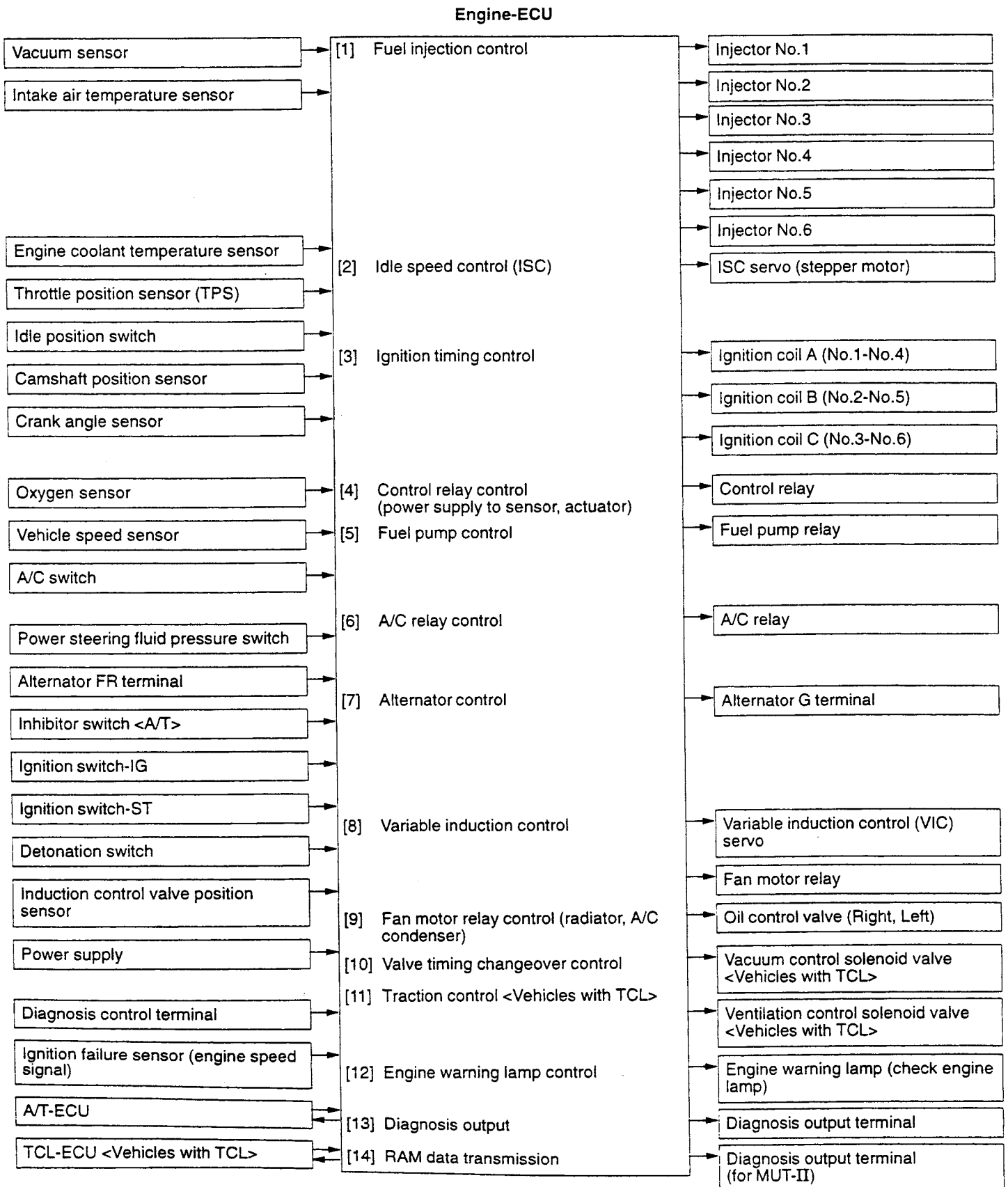

**FUEL INJECTION CONTROL**

The control method is basically the same as that for the 6A12-DOHC-MIVEC engine mounted in the

GALANT. (A sequential injection method has been used for the fuel injection method.)

**SYSTEM CONFIGURATION DIAGRAM**

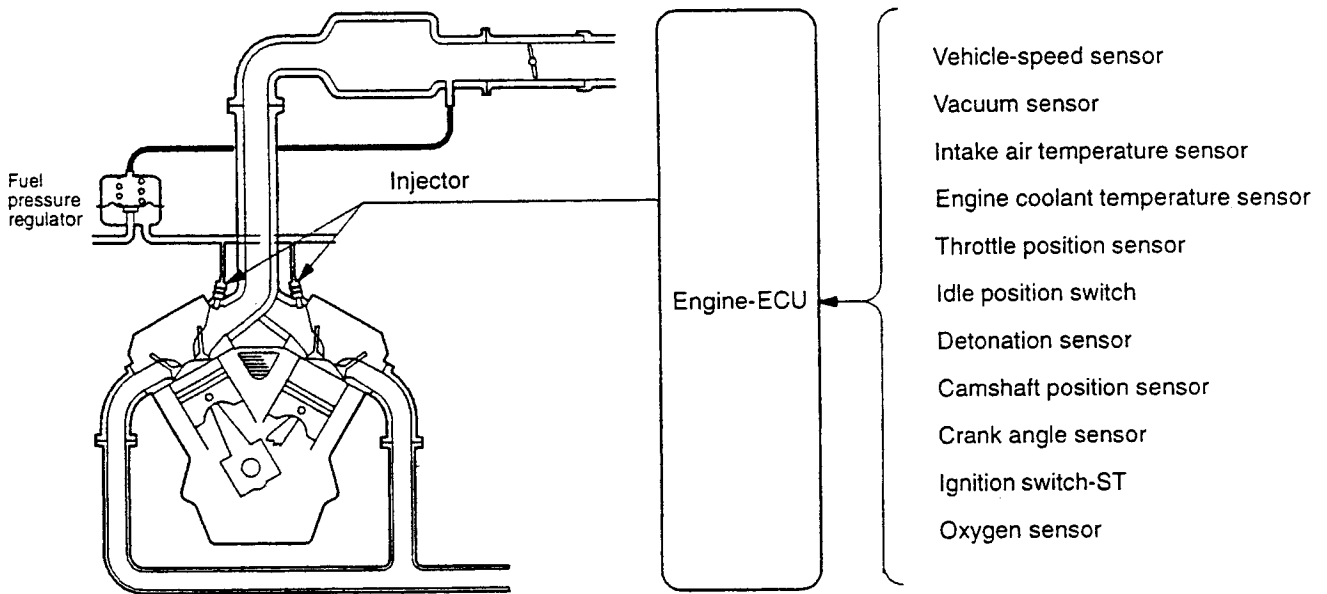

6FU2684

**IDLE SPEED CONTROL (ISC)**

The control method is basically the same as that for the 6A12-DOHC-MIVEC engine mounted in the GALANT.

**SYSTEM CONFIGURATION DIAGRAM**

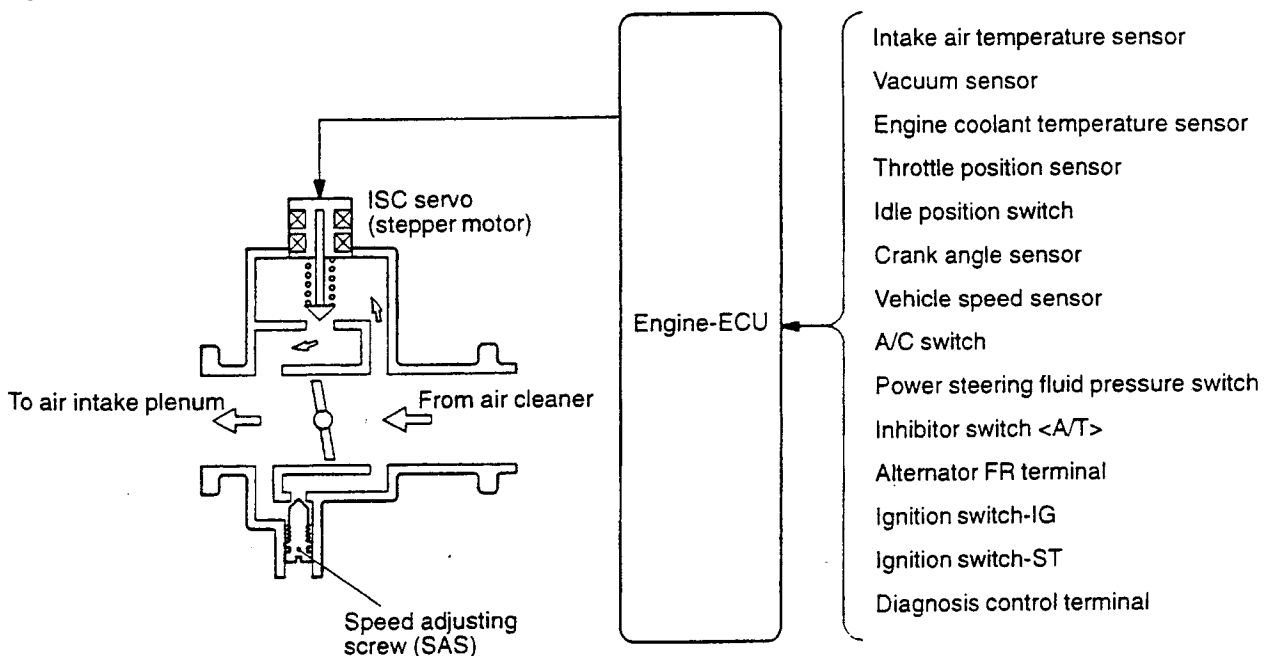

6FU2685

**IGNITION TIMING AND DISTRIBUTION CONTROL**

The control method is basically the same as that for the 6A12-DOHC-MIVEC engine mounted in the GALANT.

**SYSTEM CONFIGURATION DIAGRAM**

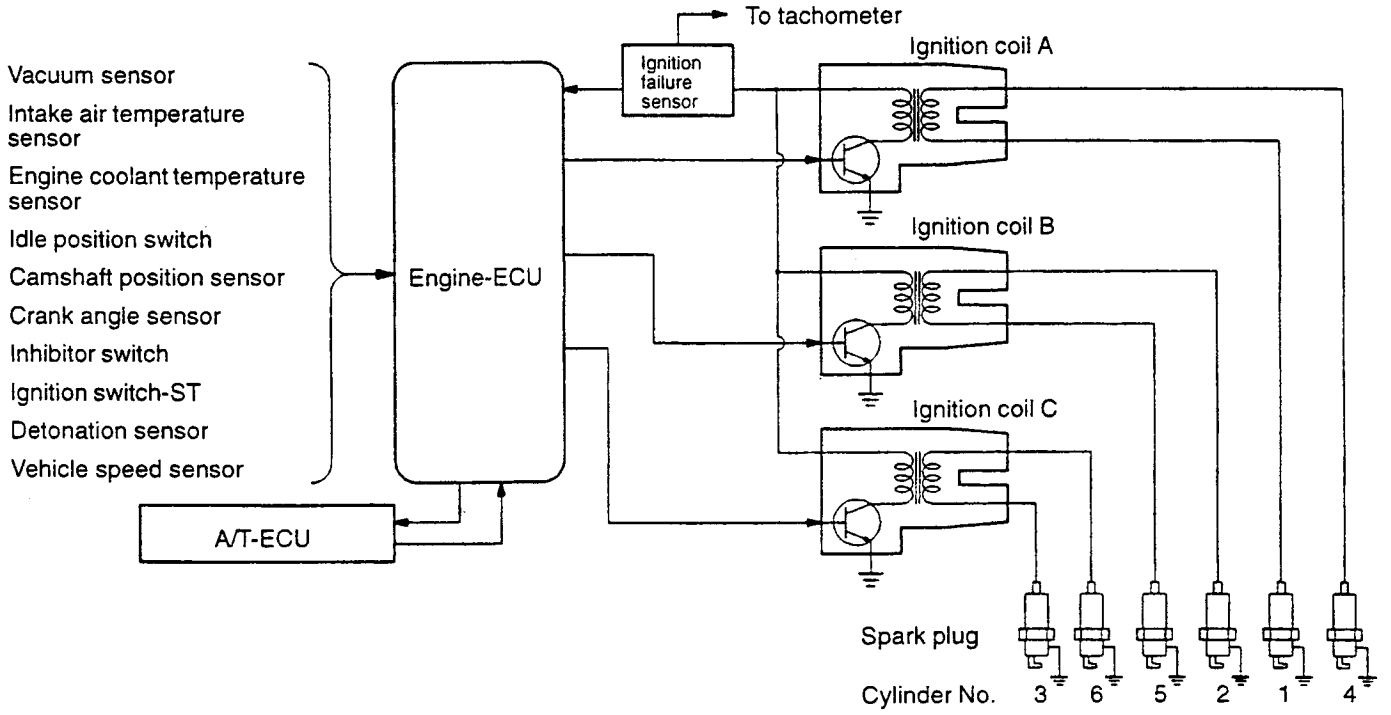

6AF0441

**POWER SUPPLY AND FUEL PUMP CONTROL, ALTERNATOR CURRENT CONTROL, VARIABLE INDUCTION CONTROL, TRACTION CONTROL, AND VALVE TIMING SWITCHING CONTROL**

These control methods are basically the same as those for the 6A12-DOHC-MIVEC engine mounted in the GALANT.

**FAN MOTOR RELAY (RADIATOR FAN, A/C CONDENSER FAN) CONTROL**

The control method is basically the same as that for the 4G9 engine mounted in the COLT/LANCER.

However, the fan operation has been changed due to partial changes in the control circuit.

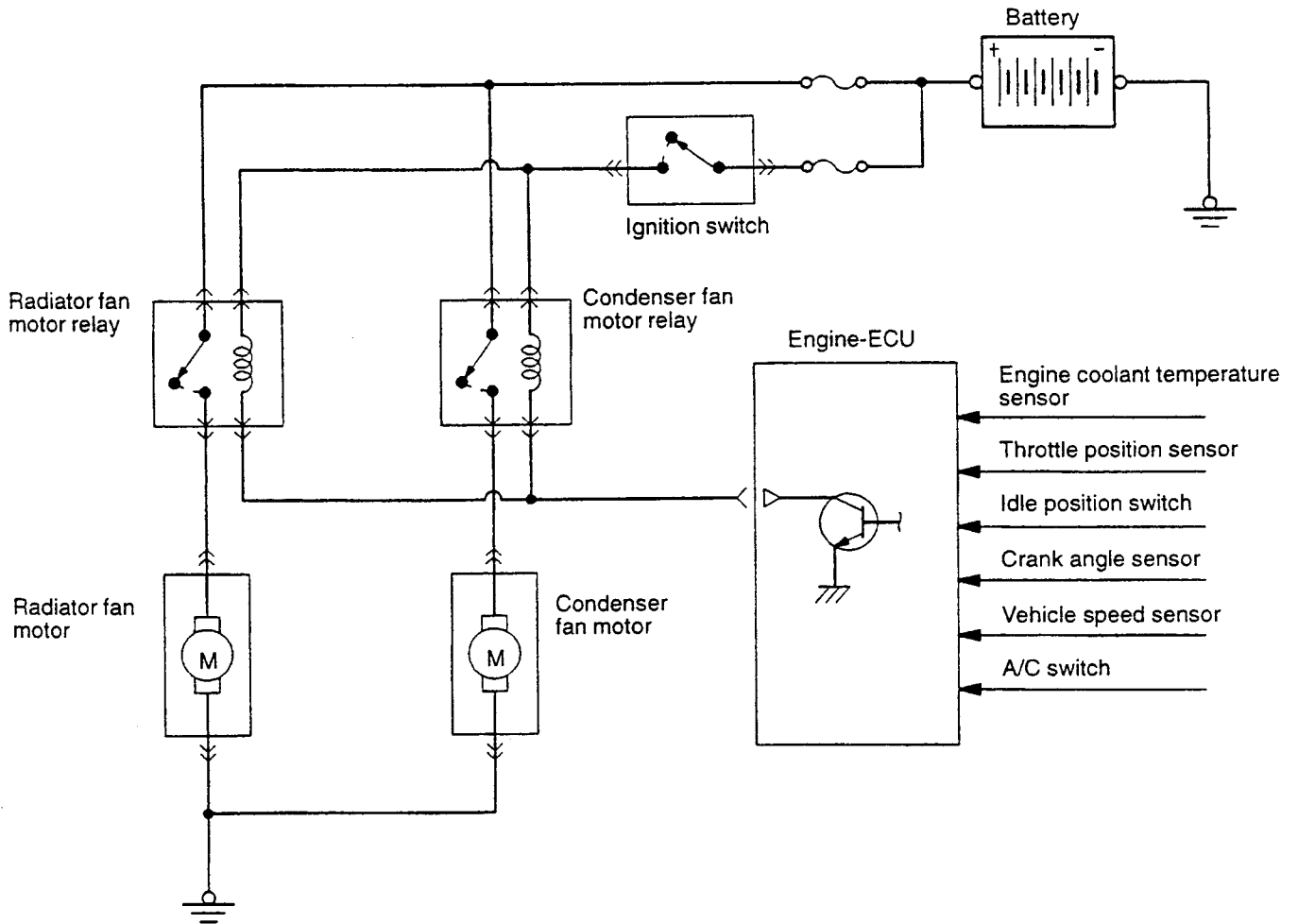

9FU0564

A/C switch	Vehicle speed [km/h]	Engine coolant temperature [°C]	Power transistor	Radiator fan;	Condenser fan;
OFF	80 or less	approx. 95 or lower	OFF	stops	stops
		approx. 95 or higher	ON	runs at high speed	runs at high speed
	80 or more	approx. 105 or lower	OFF	stops	stops
		approx. 105 or higher	ON	runs at high speed	runs at high speed
ON	-	-	ON	runs at high speed	runs at high speed

**SELF-DIAGNOSIS SYSTEM**

The engine-ECU has the following functions to simplify inspection of the system.

- Engine warning lamp control
- Diagnosis function
- Service data output

- Actuator test

**NOTE**

Refer to the Workshop Manual for details on each item.

## EMISSION CONTROL SYSTEM

The system is basically the same as that for the 6A12-DOHC-MIVEC engine mounted in the GALANT.

### EMISSION CONTROL SYSTEM DIAGRAM

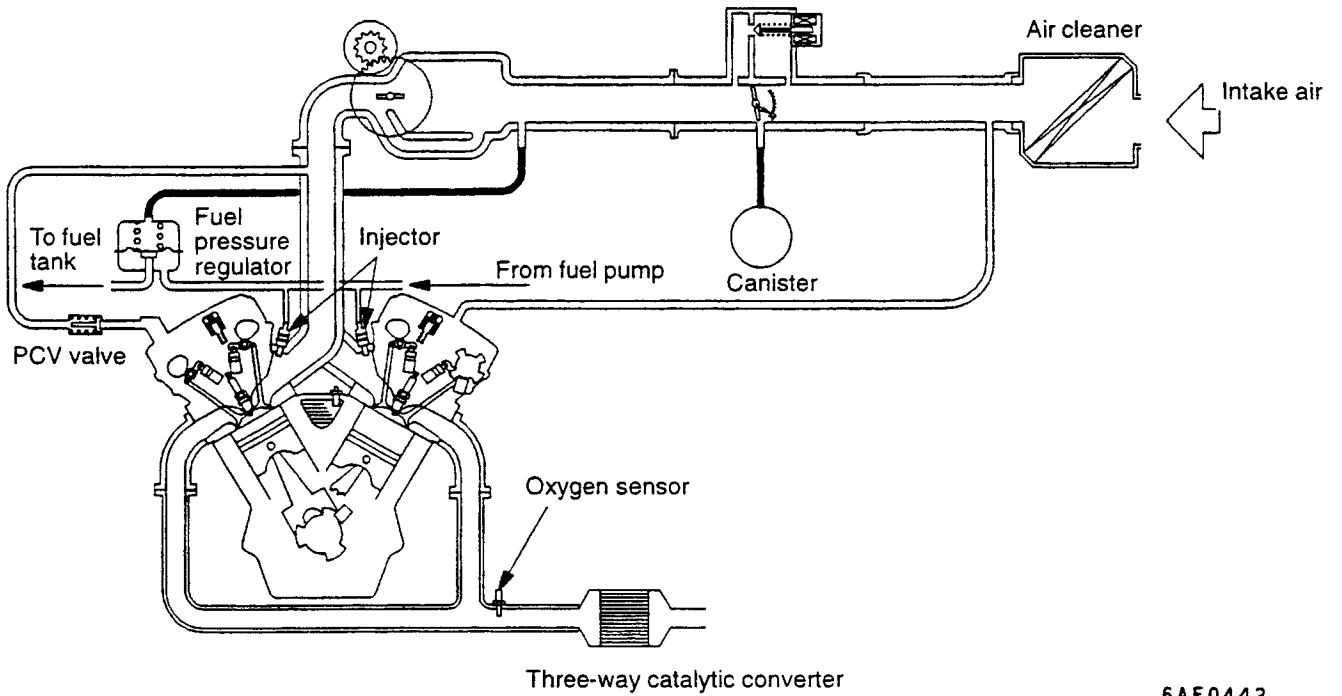

6AF0442

**MOUNT**

The proven inertial shaft support method has been incorporated for the mount. This inertial shaft support method has a structure

**FEATURES**

- By setting each mount near the engine and transmission roll shaft, the rolling movement is suppressed, and the idling vibration is reduced.
- By moving the front and rear roll stopper bracket position to the transmission housing, the transmission side roll stopper bracket is shortened. Furthermore, the rigidity is improved, and vibration and noise are reduced.
- Each insulator has outstanding vibration absorption characteristics through the installation of hollows.
- A dynamic damper is mounted on the engine mount and a mass damper is mounted on the transmission mount, allowing vibration and noise to be reduced.

that supports the upper front of the engine and upper rear of the transmission, and effectively suppresses engine vibration.

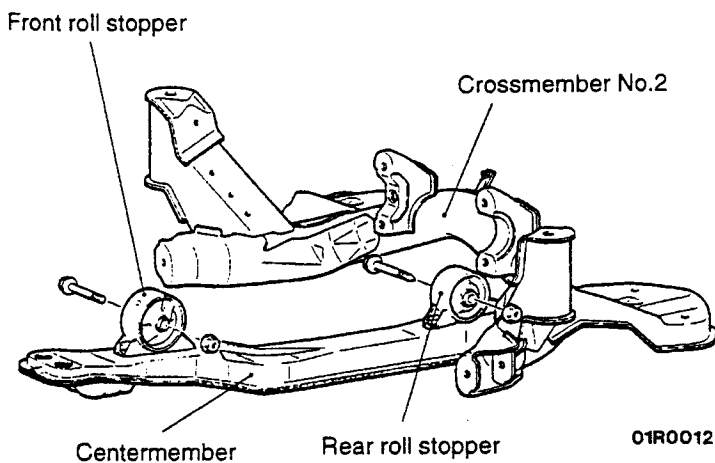
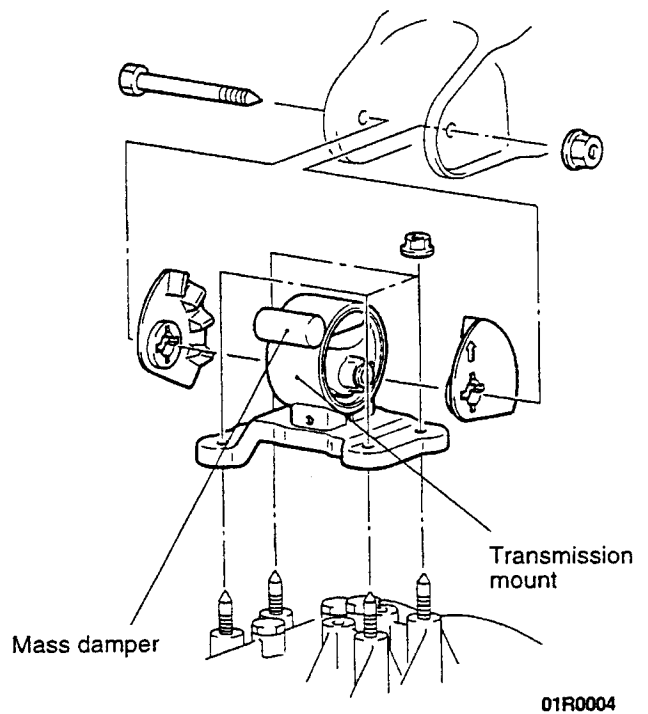
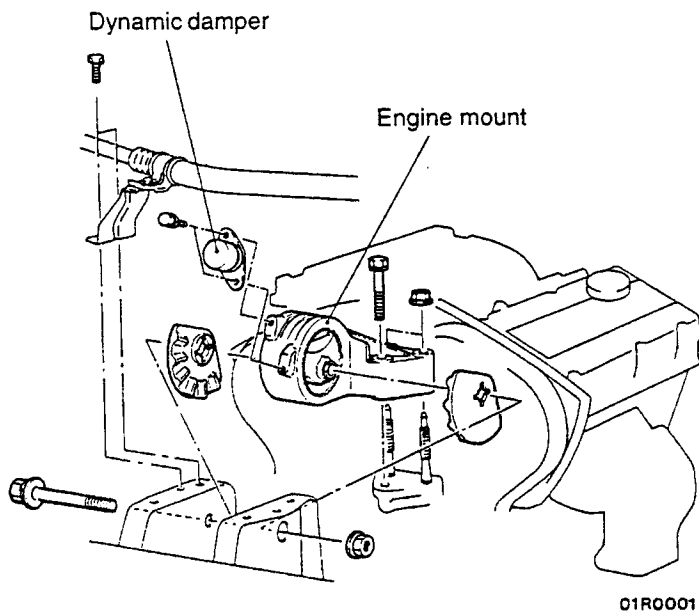

00008482

**NOTE**  
The above illustration shows the M/T vehicle.

### TCL (TRACTION CONTROL SYSTEM)

The TCL system (slip control and trace control) is incorporated to increase starting and acceleration on slippery surfaces such as snow covered roads,

and to increase steering stability and steering acceleration operability on general roads. This allows easy driving to be realized.

#### CONSTRUCTION DIAGRAM

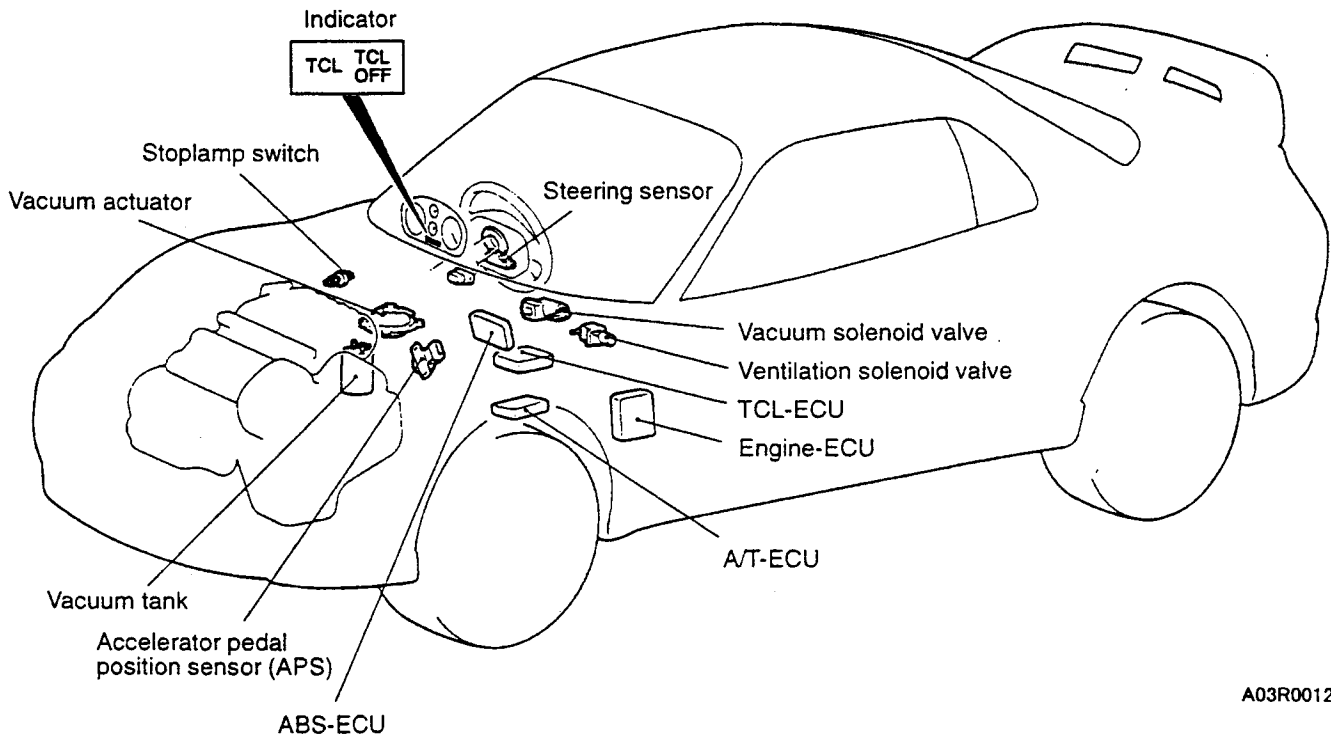

A03R0012

SYSTEM CONFIGURATION DIAGRAM

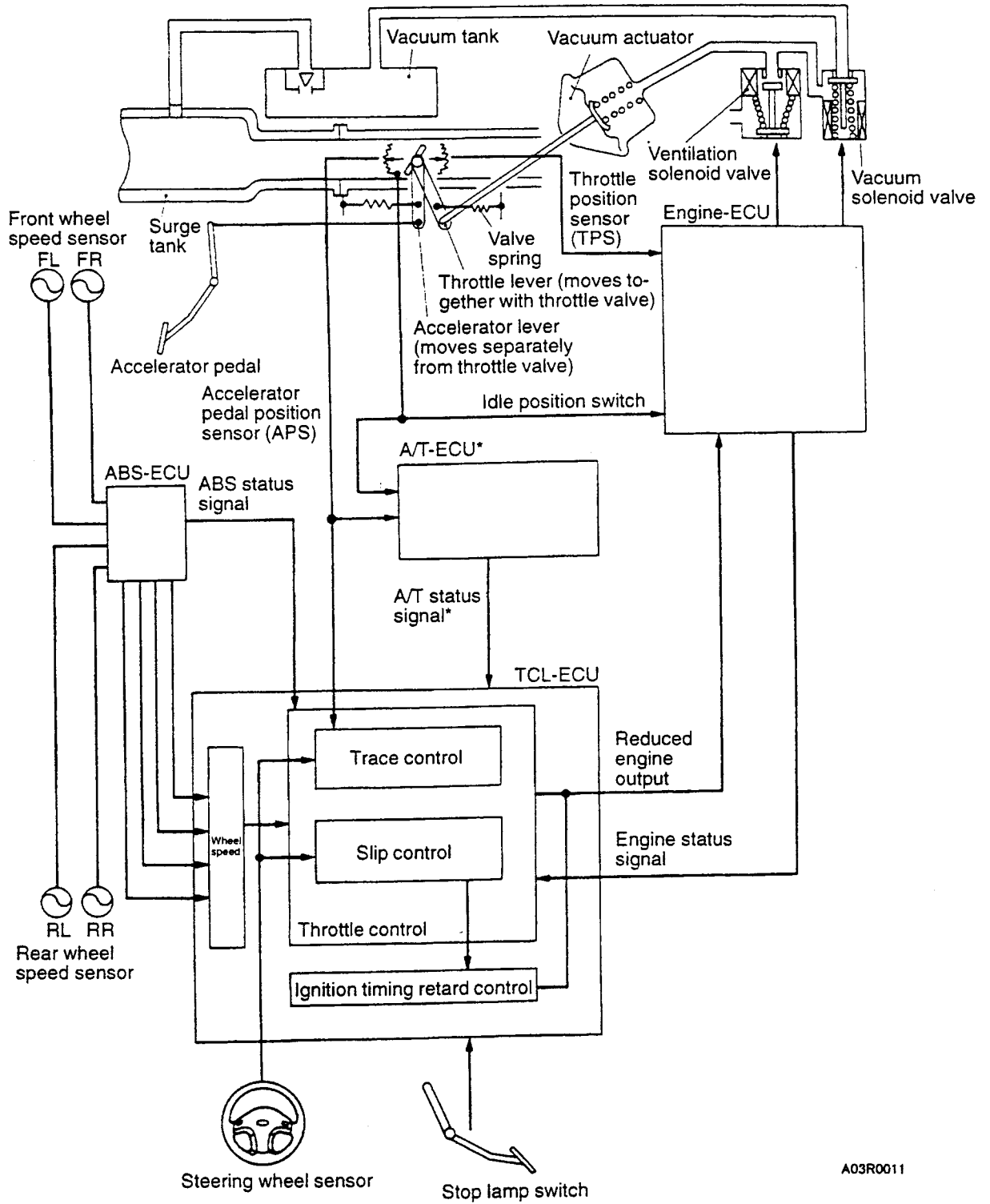

A03R0011

NOTE  
\*: Except M/T



## MAJOR COMPONENT LISTING

Part name	Function
Traction control unit (TCL-ECU)	In response to signals from the individual sensors, the TCL-ECU sends information on the target torque, ignition timing retard amount, etc. to the engine-ECU.
	Controls self-diagnosis and fail-safe functions.
	Controls diagnosis functions (when MUT-II is connected).
Engine control unit (Engine-ECU)	Sends the signals required for TCL's engine control to the TCL-ECU. <ul style="list-style-type: none"> <li>● Transmission data <ol style="list-style-type: none"> <li>1. Throttle valve opening data</li> <li>2. Engine speed</li> <li>3. CHECK ENGINE lamp: ON/OFF</li> <li>4. Idle position switch: ON/OFF</li> <li>5. Ignition switch (IG1): ON/OFF</li> <li>6. Variable valve timing operation: ON/OFF</li> <li>7. Engine specifications*: Differences in type, destination and control system, existence of communication errors</li> <li>8. Engine throttle control: failed/normal</li> </ol> </li> </ul> (*: Transmit as the engine output differs according to the engine specifications.)
	In response to an engine torque control request and ignition timing retard request from the TCL-ECU, the engine-ECU makes a correction suitable for the engine condition (cold or hot state) and controls the vacuum type throttle actuator drive solenoid valve and ignition timing.
ECU-5A/T control unit (A/T-ECU)	Sends the signals required for TCL's engine control to the TCL-ECU. <ul style="list-style-type: none"> <li>● Transmission data <ol style="list-style-type: none"> <li>1. Shift lever position: P, R, N, D</li> <li>2. Variable speed related information</li> </ol> </li> </ul>
ABS control unit (ABS-ECU)	Converts the wheel speed signal into square waves (pulses) and sends it to the TCL-ECU.
	Sends the operating status (normal or failed) of the ABS to the TCL-ECU.
Engine control relay	When the engine control relay turns ON, power is supplied to TCL-ECU. The control relay is controlled by the engine-ECU.
Steering wheel sensor	Sends a steering wheel angle to the TCL-ECU.
Accelerator pedal position sensor (APS)	Detects an accelerator pedal movement and sends a signal to the TCL-ECU.
TCL switch	Sends a signal to for switching the TCL control modes (TCL-ON, TCL-OFF) to the TCL-ECU.
TCL-OFF indicator	Lights when the TCL slip control function and trace control function are stopped (when TCL switch is pressed to OFF side). Lights or flickers when TCL function is stopped (fail-safe) by TCL-ECU self-diagnosis function.
TCL indicator	Illuminates when the TCL's slip control and trace control functions are active.
Stop lamp switch	Detects a brake pedal movement and sends a signal to the TCL-ECU.
Vacuum solenoid valve	Opens or closes the passage between the vacuum tank and vacuum actuator in response to a command from the engine-ECU when the TCL control is active.
Ventilation solenoid valve	Opens or closes the passage between the vacuum tank and atmosphere in response to a command from the engine-ECU when the TCL control is active.
Vacuum tank	Accumulates vacuum to drive the vacuum actuator.
Vacuum actuator	Opens or closes the throttle valve by means of the vacuum which is controlled by the engine-ECU.

## NOTE

For those components that are shared by other electronic controlled systems, only their functions which are associated with TCL control are described.

## CONSTRUCTION AND OPERATION

### 1. TCL Control Modes

The control mode can be selected by operating the TCL switch.

(1) TCL-ON (press switch to ON side)

(2) TCL-OFF (press switch to OFF side)  
If the system detects an error, the fail-safe mode will be entered automatically.

Control mode	System status	TCL indicator	TCL-OFF indicator	Control function (slip control)	Control function (trace control)
TCL-ON	TCL on	ON	OFF	○	○
	TCL off	OFF	OFF		
TCL-OFF	–	OFF	ON	×	×
Fail-safe	Fail-safe on	OFF	Flashing or ON	×	×

Indicator

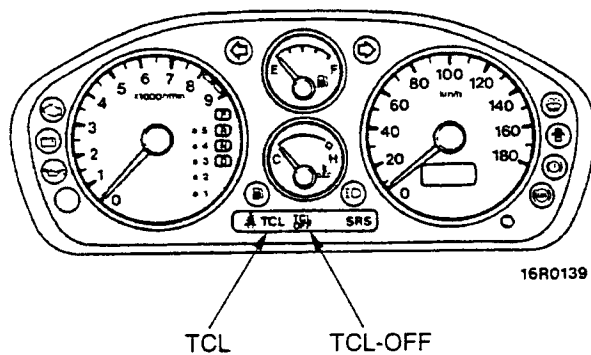

TCL switch

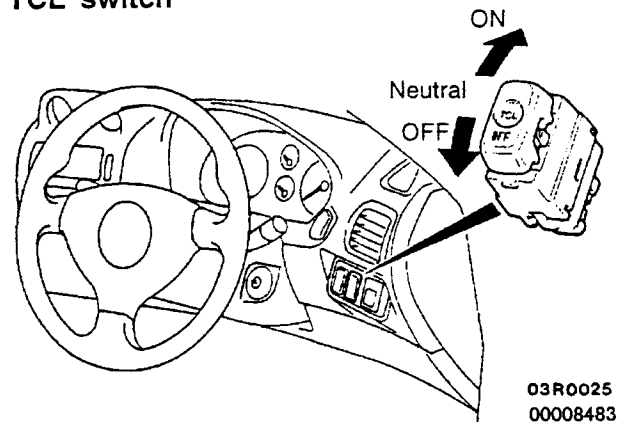

### 2. Control System

The slip control details are described as follow:

- (1) Actual drive wheel speed operation  
The actual drive wheel speed is operated from the average drive wheel (front wheel) speed.
- (2) Target engine torque extraction  
The M/T vehicle's engine torque is extracted based on the variable speed information obtained by the reference drive wheel torque obtained in the same manner as the A/T vehicle and the ratio of the drive wheel (front wheel) speed and engine speed.

(3) Others

The threshold value of each control is changed according to the difference in the engine output and drive method, etc., and is set to match the vehicle.

### 3. TCL Control Unit (TCL-ECU)

#### SERIAL COMMUNICATION BETWEEN ENGINE-ECU

The TCL-ECU carries out bidirectional serial (multiplex) communication to obtain the information required for the TCL control from the engine-ECU,

and to convey the output reduction request to the engine-ECU.

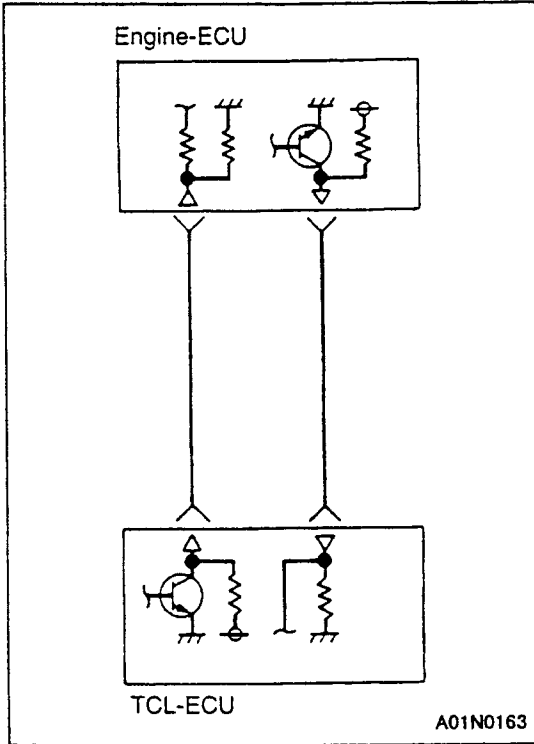

#### Major Communication Data Items

##### 1. Engine-ECU → TCL-ECU

No.	Contents
1.	Throttle valve opening data
2.	Engine speed
3.	CHECK ENGINE lamp: ON/OFF
4.	Idle switch: ON/OFF
5.	IG1 switch: ON/OFF
6.	Variable valve timing operation: ON/OFF
7.	Engine specifications: Differences in type, destination and control system, existence of communication errors
8.	Detection of a malfunction in the vacuum or ventilation solenoid valve drive circuit: failed/normal

##### 2. TCL-ECU → Engine-ECU

No.	Contents
1.	Target engine torque for reduction of engine output
2.	Ignition timing retard request level
3.	TCL control: ON/OFF
4.	Detection of data contradiction between APS and TPS: failed/normal

#### SERIAL COMMUNICATION BETWEEN AT-ECU

The TCL-ECU carries out bidirectional serial (multiplex) communication to obtain the information required for engine control from the AT-ECU.

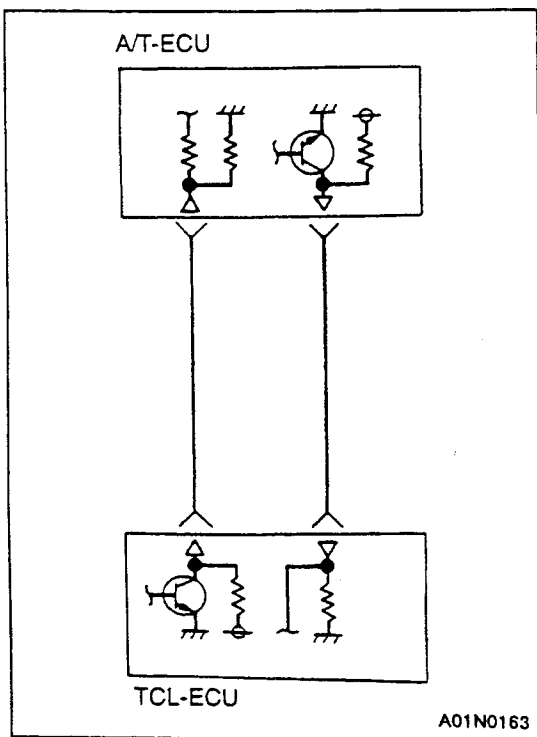

#### Major Communication Data Items

##### 1. AT-ECU → TCL-ECU

No.	Contents
1.	Shift lever position: P, R, N, D
2.	Variable speed related information

##### 2. TCL-ECU → AT-ECU

No.	Contents
1.	Speed variation prohibit signal

**FAIL-SAFE FUNCTION**

The TCL-ECU always monitors the input and output signals. When it detects a failure in the system, it commands the following actions.

**During No Control**

- The engine control is cancelled.

**During Control**

- Engine output command is gradually made to conform to the normal accelerator pedal operation.
- Ignition timing retard amount is gradually reduced and the retard command is finally cancelled.

**DIAGNOSIS FUNCTIONS**

The TCL-ECU has the following functions to facilitate inspection of the TCL system.

- Outputting diagnosis code
- Outputting service data

**NOTE**

An actuator test function, executed on the engine-ECU side, is also provided. (Refer to P.1-9.)

**DIAGNOSIS CODES**

There are 24 diagnosis items, including during correct operation. The memory with backup power supply is used, so even if the engine is stopped,

the data is held until the battery terminal is disconnected.

**Diagnosis Results Display Items When Using MUT-II**

Code No.	Major contents of diagnosis
11	APS output abnormal
12	APS or TPS defective
13	APS or TPS output abnormal
23*	Stop lamp switch
24	TCL switch short-circuited
26*	Ignition switch (IG2) line open-circuited
27*	ECU power voltage too low
31	Right front wheel speed sensor open-circuited
32	Left front wheel speed sensor open-circuited
33	Right rear wheel speed sensor open-circuited
34	Left rear wheel speed sensor open-circuited
35*	Either of the rear wheel speed sensors defective
36	Both of the rear wheel speed sensors defective
41	Steering wheel sensor (ST-1) open-circuited
42	Steering wheel sensor (ST-2) open-circuited
43	Steering wheel sensor (ST-N) open-circuited
44	Steering wheel sensor (ST-1 or ST-2) short-circuited
45	Steering wheel sensor (ST-N) short-circuited
71	Error in communication with engine-ECU
72	CHECK ENGINE lamp ON
73	Failure in throttle control of engine-ECU
74	Error in communication with A/T-ECU
76*	ABS failure

**NOTE**

The code Nos. marked \* are output only while the failure persists. If control determines that the failure condition has disappeared, it clears the associated code No. stored in memory.

## SERVICE DATA

Of the data input to the TCL-ECU, the following items can be read using the MUT-II.

No.	Service data item	Indication unit
11	APS opening	mV
13	TPS opening	mV
15*1	State of input from inhibitor switch	R, N, D, P
16*1	Shift position	4, 3, 2, 1
21	State of input from idle position switch	ON/OFF
22	State of input from ignition switch	ON/OFF
23	State of input from stop lamp switch	ON/OFF
24	State of input from TCL-ON switch	ON/OFF
25	State of input from TCL-OFF switch	ON/OFF
27	ECU power voltage	V
31	Right front wheel speed	km/h
32	Left front wheel speed	km/h
33	Rear right wheel speed	km/h
34	Rear left wheel speed	km/h
40	Engine speed	r/min
44	Steering angle	° (deg)
45	Steering neutral point learning	ON/OFF
51	Slip control condition	ON/OFF
52	Trace control condition	ON/OFF
74	Steering wheel sensor (ST-N) signal	HIGH/LOW
75	Steering wheel sensor (ST-1) signal	HIGH-LOW
76	Steering wheel sensor (ST-2) signal	HIGH-LOW
81	Engine model	6A12
82	Engine valve type	DOHC
83	Engine air induction type	N/A
84	Engine classification	MIVEC

## NOTE

- (1) \*1: A/T
- (2) Item No. 44 indicates the right side as R and the left side as L using the neutral position (at ignition key "ON" before neutral position teaching) as 0°.
- (3) Item No. 45 indicates "ON" when the steering neutral position has been taught.

# ACCELERATOR SYSTEM

## ACCELERATOR PEDAL, ACCELERATOR CABLE

A cable type accelerator unit and suspended type pedal are incorporated. A resin bush is mounted at the end of the accelerator cable, allowing the drive conveyed from the cable

to the pedal to be reduced. For the A/T vehicle, the accelerator pedal switch used as the ELC-A/T control sensor when stopped is mounted on the pedal support member.

### CONSTRUCTION DIAGRAM

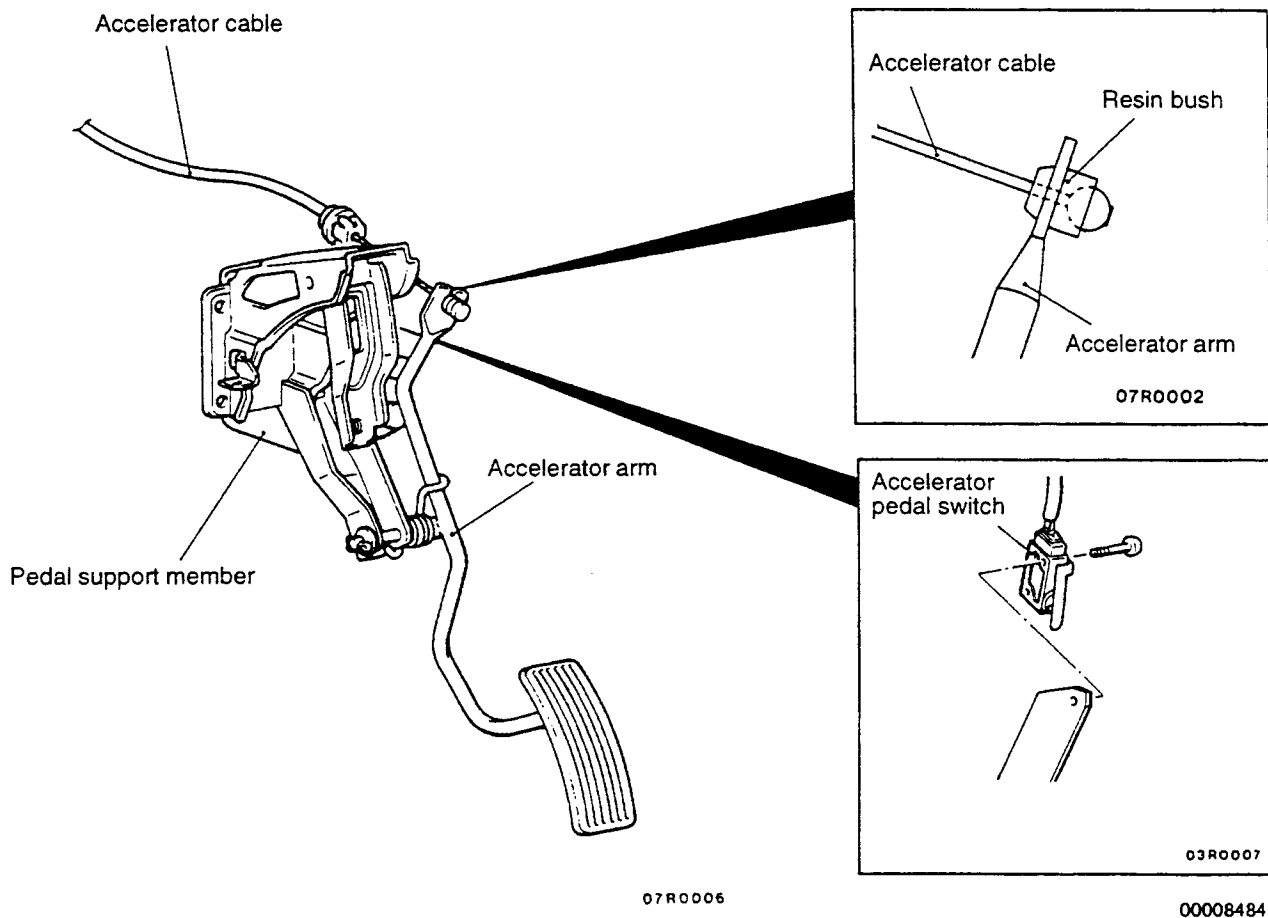

---

# POWER TRAIN

## CONTENTS

<b>CLUTCH</b> .....	<b>2</b>	<b>AUTOMATIC TRANSMISSION</b> .....	<b>13</b>
Specifications .....	2	Specifications .....	13
Clutch Control .....	2	Sectional View .....	14
<b>MANUAL TRANSMISSION</b> .....	<b>3</b>	Transmission .....	15
Specifications .....	3	Hydraulic Control System .....	28
Sectional View .....	4	Electronic Control System .....	41
Transmission Case .....	5	Transmission Control .....	55
Power Train .....	5	<b>FRONT AXLE</b> .....	<b>56</b>
Synchronizer .....	8	Features .....	56
Gearshift Control .....	10	Specifications .....	56
Clutch Control .....	11	<b>REAR AXLE</b> .....	<b>57</b>
Speedometer Gear .....	11		
Transmission Control .....	12		

---

## CLUTCH

A single dry disc-type diaphragm spring method has been incorporated for the clutch, and a hydraulic type operating method has been introduced. A flexible flywheel has been incorporated. By reducing

the centrifugal force of the flywheel during high-speed rotation, pedal vibration has been reduced, and clutch engagement has been improved.

## SPECIFICATIONS

Items	Specifications
Clutch disc type	Single dry disc type
Clutch disc facing diameter O.D. × I.D. mm (in.)	225 × 150
Clutch cover type	Diaphragm spring strap drive type
Clutch cover setting load N	4,510
Clutch operating method	Hydraulic type
Clutch release cylinder I.D. mm	20.6
Flexible flywheel	Provided

## CLUTCH CONTROL

The hydraulic type clutch control has been incorporated for all vehicles.

## CONSTRUCTION DIAGRAM

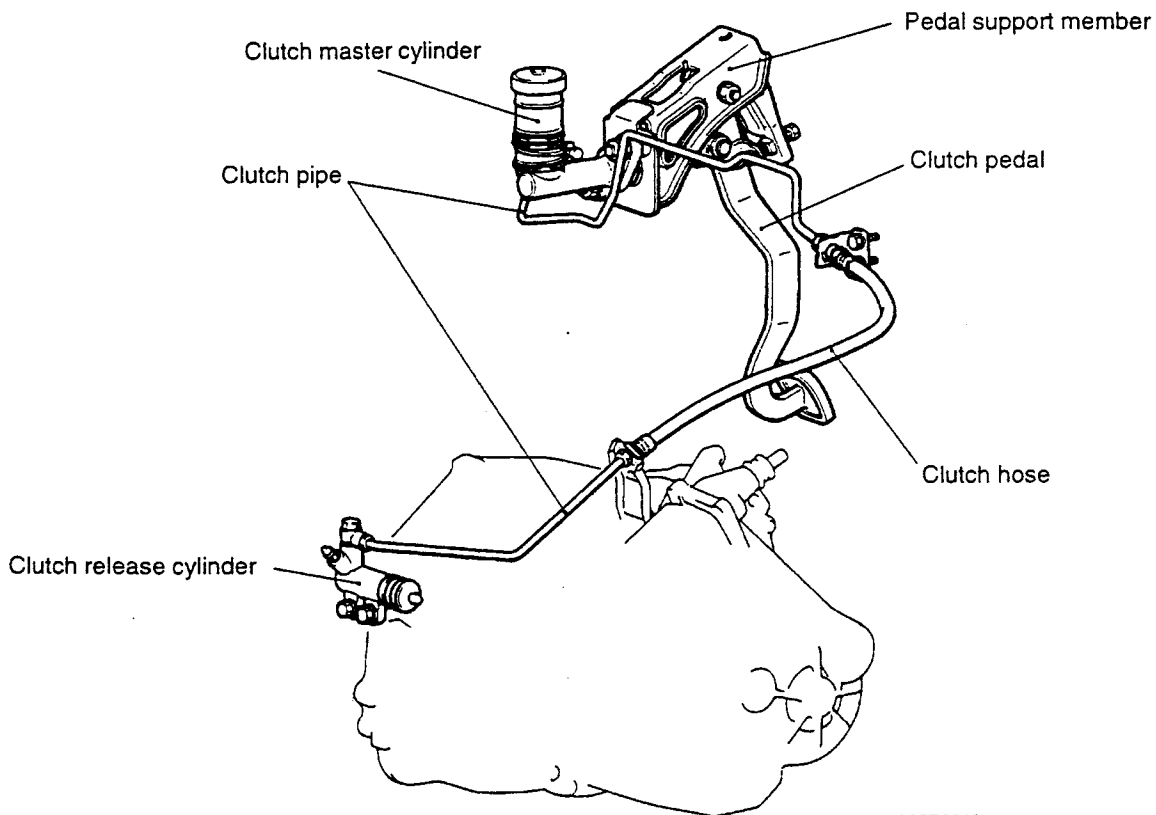

A08R0010



## MANUAL TRANSMISSION

The F5M42 manual transmission, a new development, has been adopted.

The new transmission, developed after a complete review of the gear specifications, synchronizer specifications, case rigidity, and gearshift and allied

### Higher commodity value

- (1) Keyless synchronizers have been adopted for all the speeds to assure snappy shift feeling.
- (2) As the 3rd, 4th, 5th and reverse gears, high meshing ratio gears have been adopted to reduce gear noise.
- (3) For the 2nd and 3rd gears, one-way flow chamfering has been adopted to assure resistance-free shift feeling.
- (4) The reverse gear is a constant-mesh type and a synchronizer is used for the reverse gear also in order to improve operability.

elements, assures higher reliability and dependability.

The features of the F5M42 may be itemized as shown below.

### Better serviceability

The release bearing retainer has been changed to a separate entity for easier replacement.

## SPECIFICATIONS

Transmission model		F5M42
Transmission type		5 forward, one reverse, constant mesh
Gear ratio	1st	3.583
	2nd	1.947
	3rd	1.379
	4th	1.030
	5th	0.820
	Reverse	3.363
Final gear ratio (differential gear ratio)		4.312

SECTIONAL VIEW

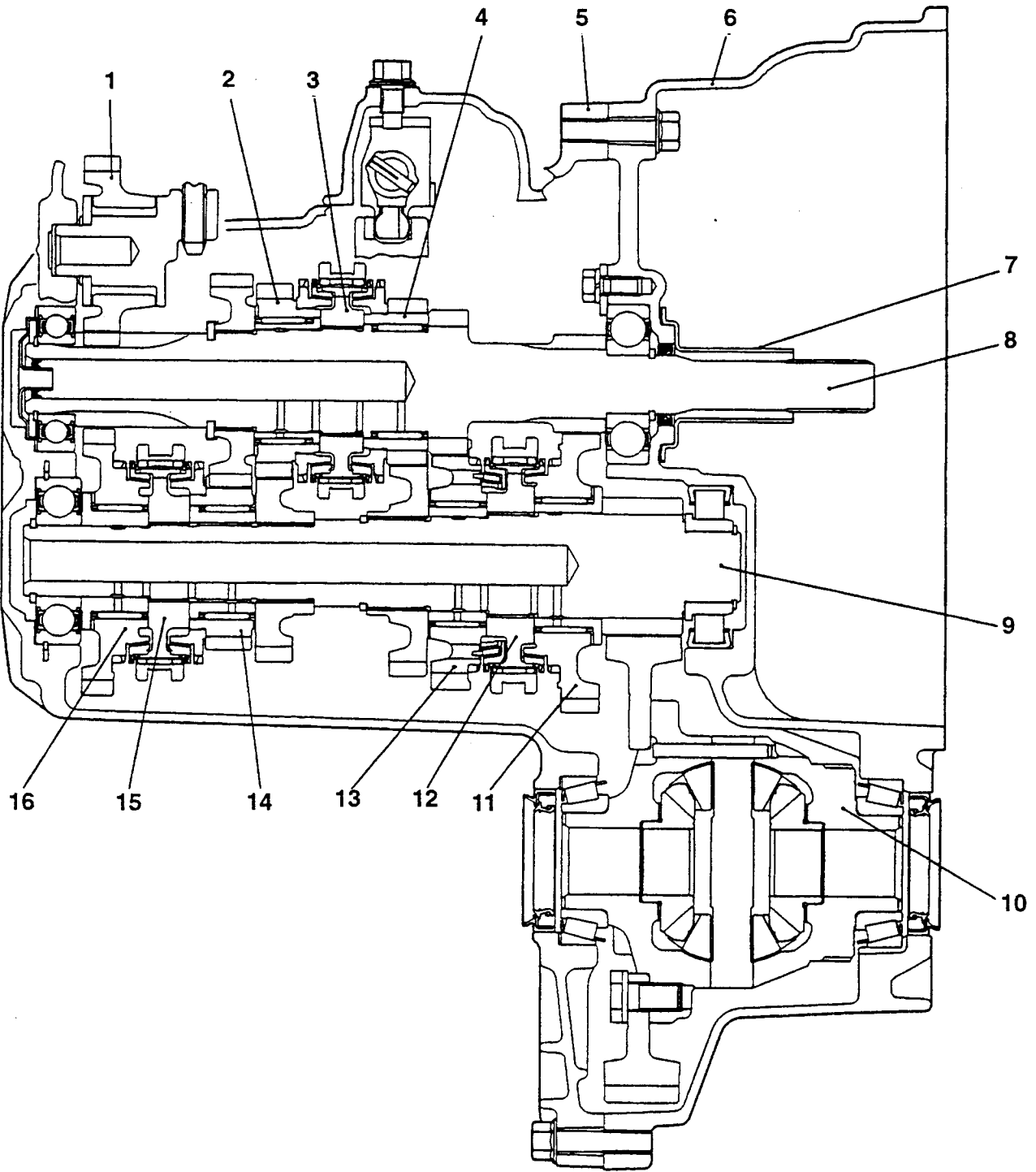

ATFM0601

- 1. Reverse idler gear
- 2. 4th speed gear
- 3. 3rd - 4th speed synchronizer
- 4. 3rd speed gear
- 5. Transmission case
- 6. Clutch housing
- 7. Release bearing retainer
- 8. Input shaft

- 9. Output shaft
- 10. Differential
- 11. 1st speed gear
- 12. 1st - 2nd speed synchronizer
- 13. 2nd speed gear
- 14. 5th speed gear
- 15. 5th - reverse synchronizer
- 16. Reverse gear

**TRANSMISSION CASE**

The transmission case comprises the clutch housing, under cover, control housing and release bearing retainer as shown below. They offer the following features:

(1) For weight reduction, the case, housings have been changed to die-cast aluminum type, and the cover, retainer changed to a sheet metal type.

(2) For better sealing, a liquid gasket (FIPG) has been adopted for each mating surface.

(3) For better serviceability, the release bearing retainer has been changed to a separate type so that it can be replaced without disassembling the transmission.

The area  shows where the FIPG is used.

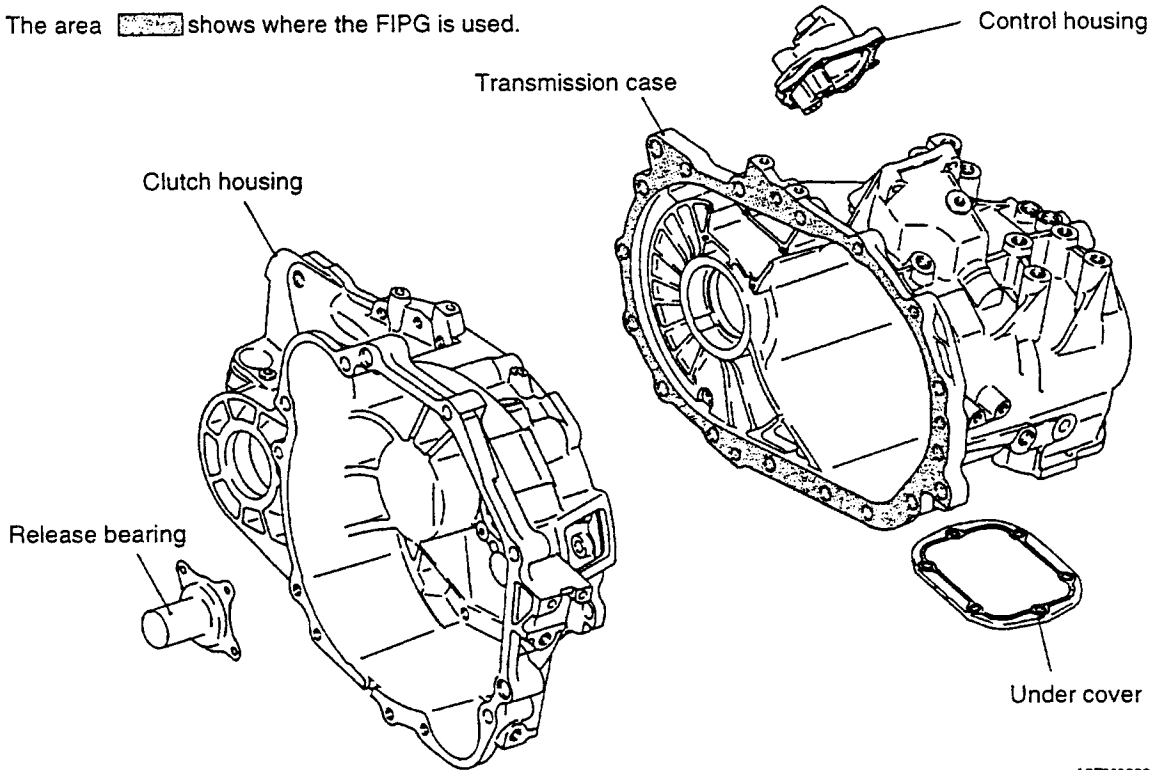

A9FM0030

**POWER TRAIN**

To comply with the two-shaft design of the transmission, the power train has been changed to new design that provides proper gear ratio and

torque capacity suitable for the engine, while suppressing gear noise.

**POWER FLOW**

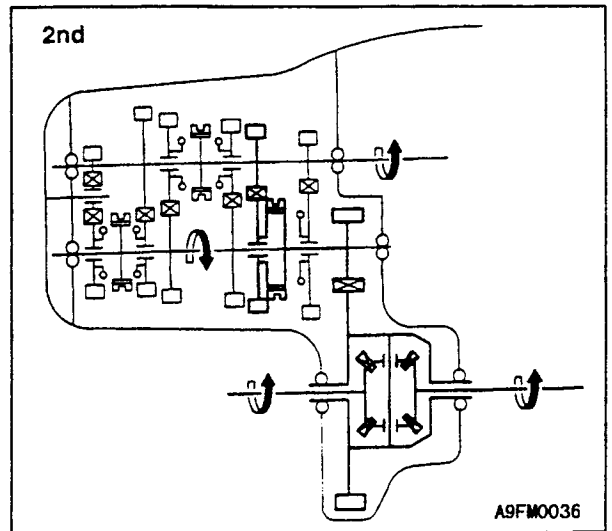
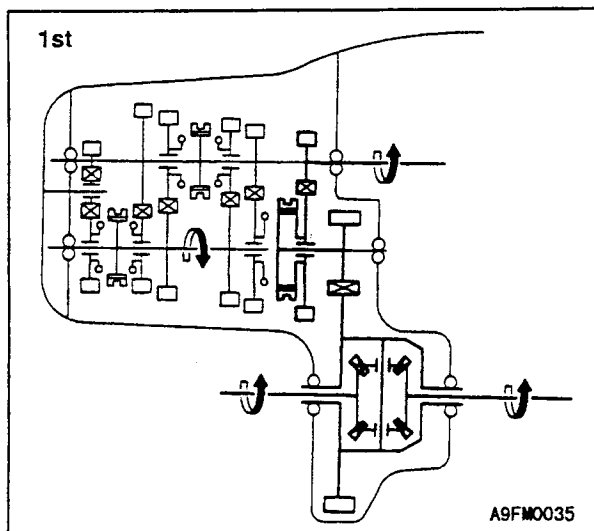

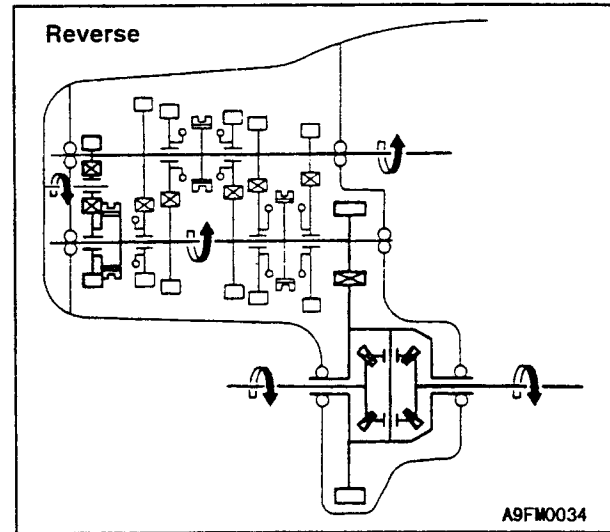
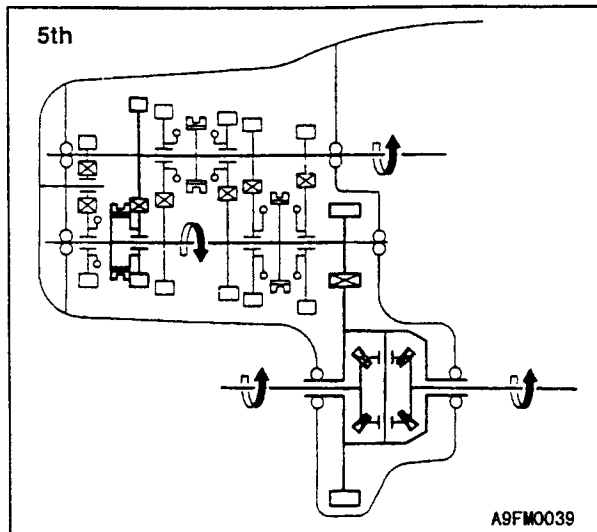
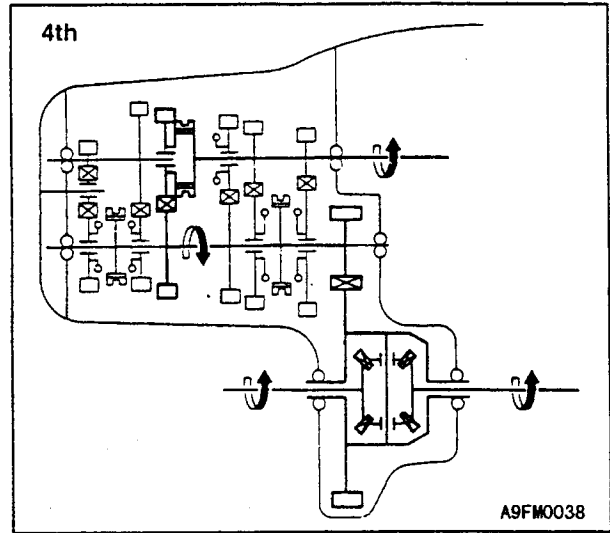
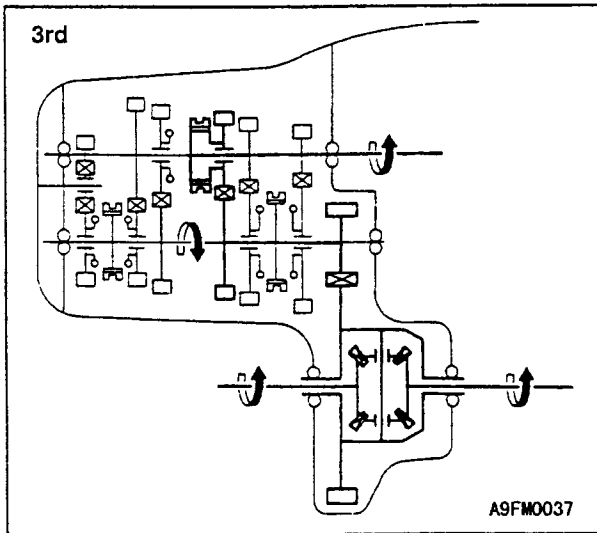

**INPUT SHAFT ASSEMBLY**

The input shaft comprises an input shaft which has the 1st gear, 2nd gear and reverse gear directly cut, the 3rd – 4th synchronizer assembly arranged on the shaft, and the 5th gear spline-coupled.

A snap ring and stopper plate fixing method has been used for retaining the bearings and gears. As lock nuts are not used, the serviceability has been improved.

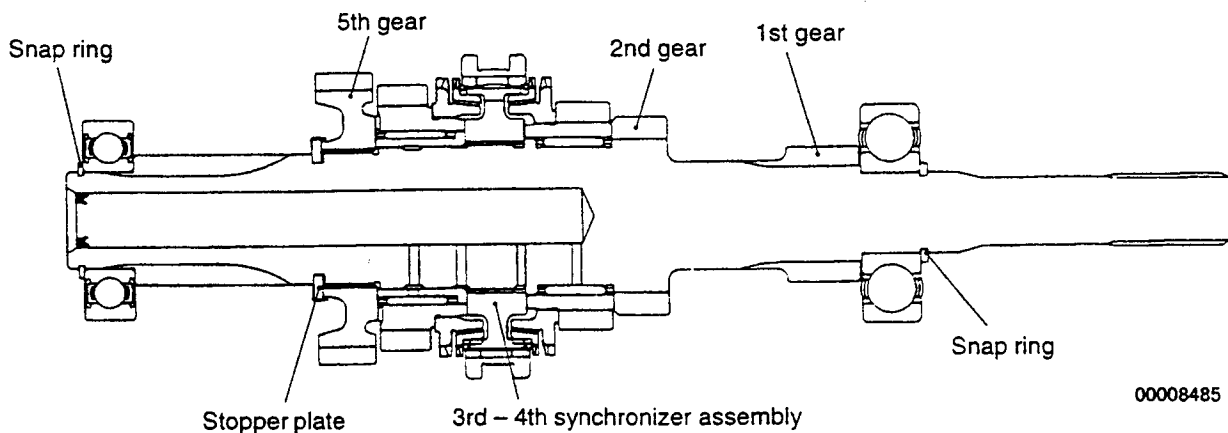

00008485

**OUTPUT SHAFT ASSEMBLY**

The output shaft comprises an output shaft which has the final reduction gears directly cut, the 1st – 2nd synchronizer assembly and 5th – reverse synchronizer assembly arranged on the shaft, and the 3rd and 4th gears spline-coupled.

A snap ring has been used for retaining the bearings and gears as with the input shaft, and thus the serviceability has been improved.

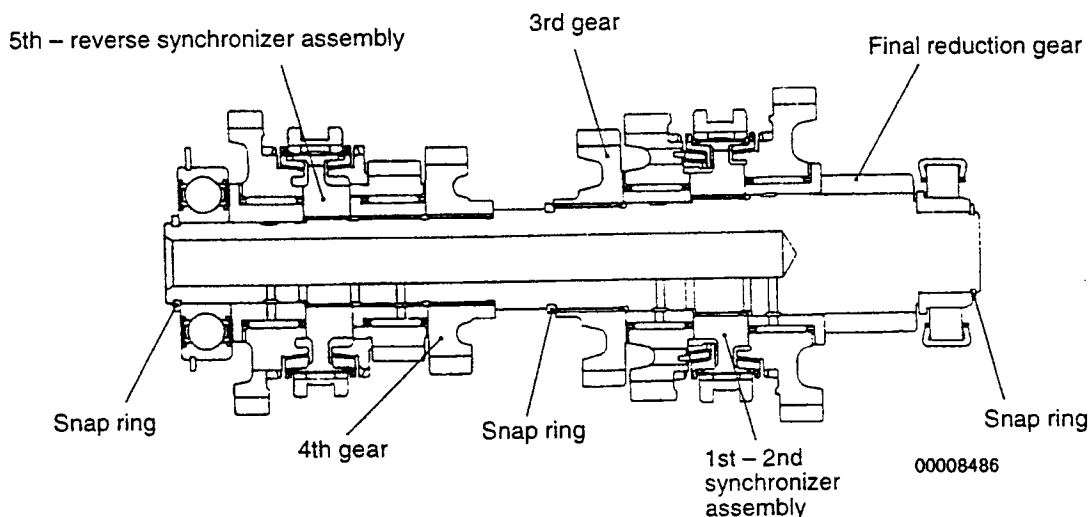

**REVERSE IDLER GEAR ASSEMBLY**

As a constantly engaged type reverse gear has been used, the idler shaft has been arranged on the rear end of the transmission case, and the reverse idler gear has been fixed.

By removing the under cover, the reverse idler gear assembly can be easily removed and reinstalled.

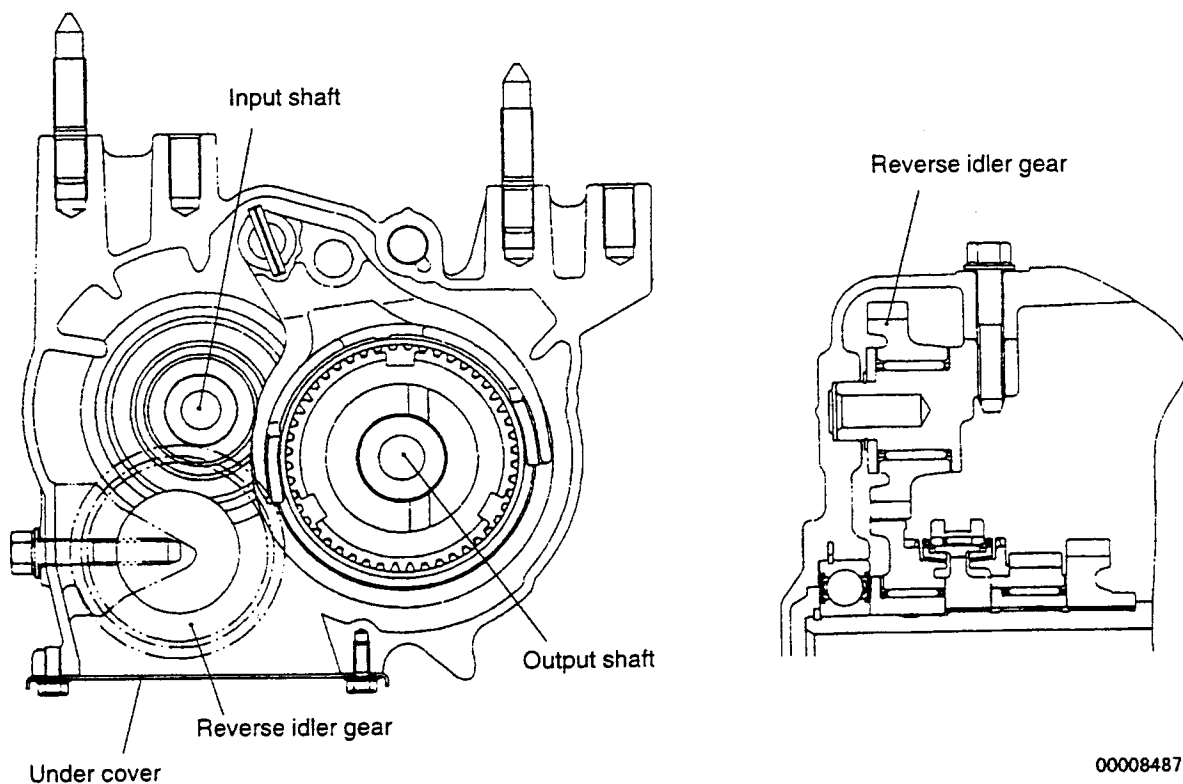

00008487

## SYNCHRONIZER

The features of the F5M42 synchronizer mechanism include the following:

- (1) A keyless synchronizer has been incorporated for all speeds (including reverse), allowing an improved feel to be achieved during shifting.
- (2) A one-way-flow chamfering has been introduced for the 2nd and 3rd clutch gear allowing a smooth feel without snagging during shifting.
- (3) A double cone synchronizer has been incorporated for the 2nd speed, allowing the operating force during shifting to be reduced.
- (4) A synchronizer has been incorporated for the reverse gear, allowing the operability to be improved.

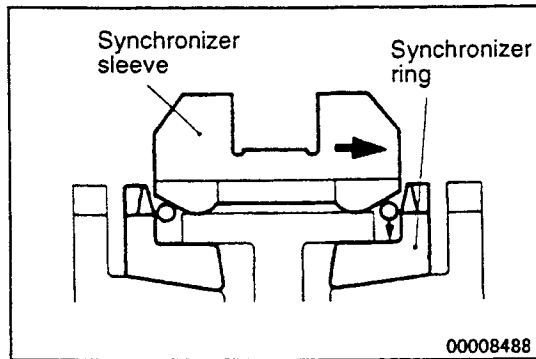
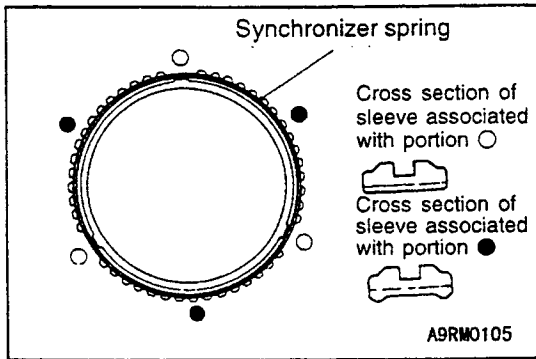

## KEYLESS SYNCHRONIZER

The keyless synchronizer consists of a ring-like synchronizer spring and a synchronizer sleeve that has three projecting portions by which the synchronizer spring itself is made to perform the function of a synchronizer key, thereby eliminating the need for a key.

The synchronizer spring, guided by the projecting portions (marked ○) of the synchronizer ring, makes contact with the synchronizer ring.

The spline portions of the synchronizer sleeve that correspond to the center portions (marked ●) between the projections of the synchronizer ring have projecting portions at both ends. When a shift is started, the synchronizer sleeve is moved, and its projecting portions push the synchronizer spring. As a result, the synchronizer spring pushes the adjoining synchronizer ring, so a frictional force is generated between the synchronizer ring and clutch gear to start the synchronizing function.

The synchronizer sleeve compresses the synchronizer spring as it moves. When it comes in contact with the chamfered portion of the synchronizer ring, it exerts a larger force as it pushes the synchronizer ring against the clutch gear. Accordingly, a stronger synchronizing function is accomplished to synchronize the synchronizer ring and clutch gear. Thereafter, the synchronizer sleeve comes in mesh with the clutch gear to complete the shift.

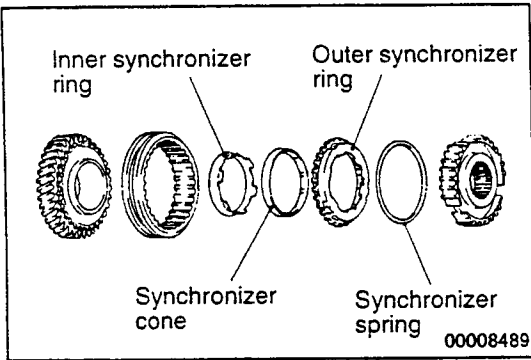

**DOUBLE CONE SYNCHRONIZER**

A double cone synchronizer has been incorporated in the 2nd gear. The double cone synchronizer has two synchronizer rings, one each on the inner and outer sides, and is set to sandwich the synchronizer cone.

The two synchronizer rings engage with each other, and rotate integrally with the synchronizer hub.

The protrusions on the synchronizer cone are fit into the holes on the 2nd gear, and the synchronizer cone rotates integrally with the 2nd gear.

The movement of the double cone synchronizer is the same as a typical synchronizer. However, as the synchronous amount surfaces are on both sides of the synchronizer cone, the synchronization capacity is greatly increased, and as a result the operating force during shifting is reduced.

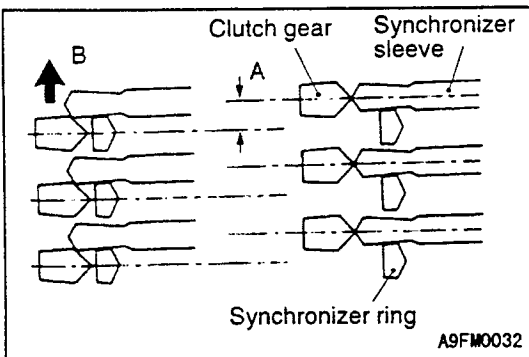
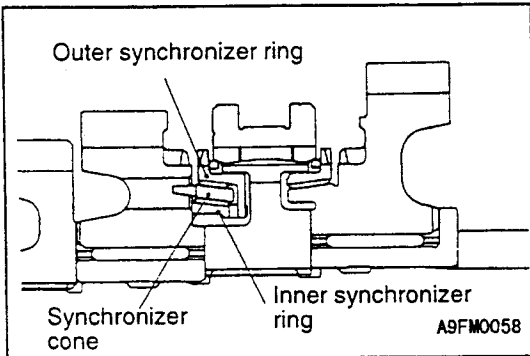

**ONE-WAY FLOW CHAMFERING**

After the synchronizing function has been completed by the synchronizer mechanism, the synchronizer sleeve passes through the synchronizer ring and comes in mesh with the clutch gear.

At this point, the synchronizer ring is not pressed against the clutch gear, and the clutch gear begins to move against the synchronizer sleeve. With the conventional chamfered shape, when the gear and sleeve starts meshing at the position (A) shown at the left, the synchronizer sleeve pushes the clutch gear in the opposite direction to the rotating direction of the clutch gear (B). Therefore, some resistance is felt at the time of a shift.

To reduce this resistance, the chamfered portions of the 2nd and 3rd clutch gears have been changed to take the form of a one-way flow as shown at the left so as to reduce the portion (C) where the synchronizer sleeve interferes with the clutch gear movement, and thereby reduce the resistance.

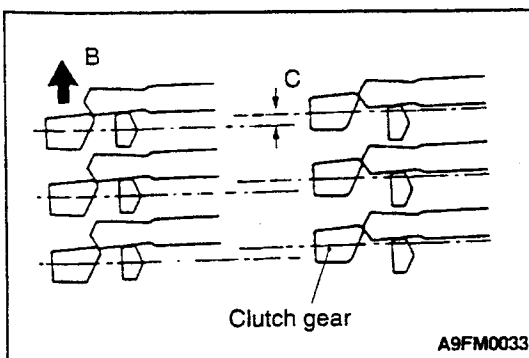

**GEARSHIFT CONTROL**

Gearshift control is essentially the same cable type as before. A shift lug is selected by the select lever and is moved by the shift lever. The shift control system has been centralized in the control housing for higher rigidity and easier removal operations.

The system uses the same gear disengagement preventing mechanism, double mesh preventing mechanism and accidental reverse operation preventing mechanism as before.

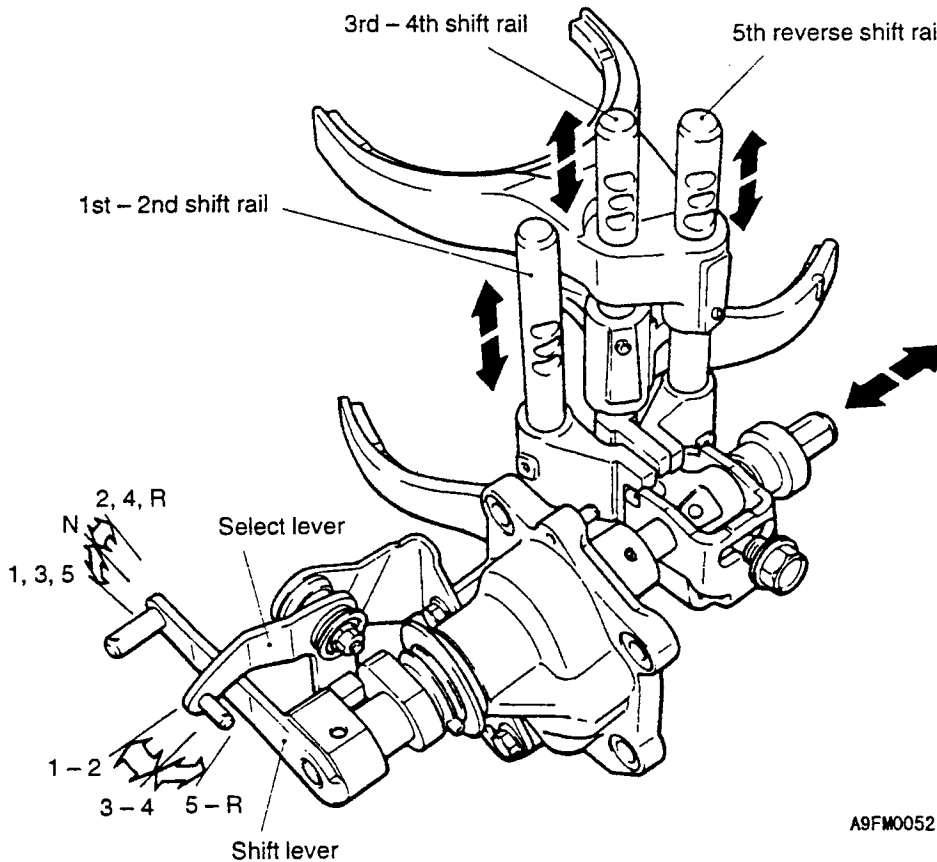

A9FM0052

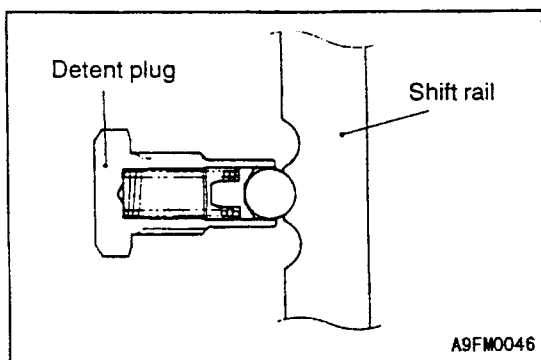

A9FM0046

**GEAR DISENGAGEMENT PREVENTING MECHANISM**

The same grooves as before have been made in the shift rail to prevent disengagement of the gear and improve crisp feeling by the detent function.

The detent spring, detent ball and plug have been integrated in a single unit for easier removal and installation.

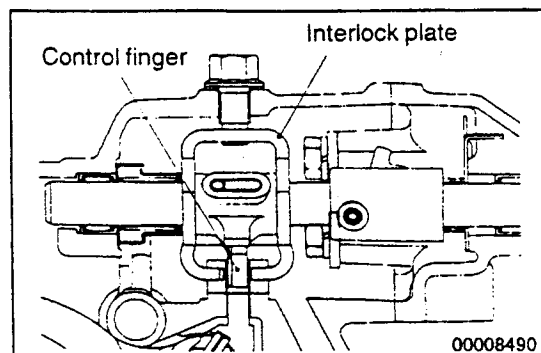

00008490

**DOUBLE MESH PREVENTING MECHANISM**

The double mesh preventing mechanism is a proven mechanism using an interlock plate.

The interlock plate restricts movement of the control finger to make sure that the control finger is allowed to move only when it is in mesh with a shift lug, thereby preventing double mesh.



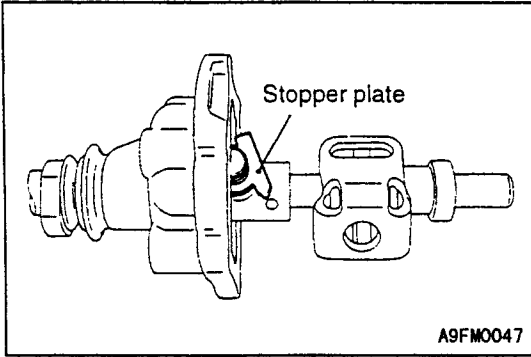

**ACCIDENTAL REVERSE OPERATION PREVENTING MECHANISM**

The same stopper plate type accidental reverse operation preventing mechanism as before has been adopted. When an attempt is made to shift directly from 5th to reverse, the stopper plate is pressed against the stopper bracket to block the shift.

**CLUTCH CONTROL**

Clutch control is the same type as before in which the release bearing is pushed by the release fork. The release fork is mounted on the clutch housing with a fulcrum in between. Its end is inserted in

the bore of the release bearing and is held in position by a return clip.

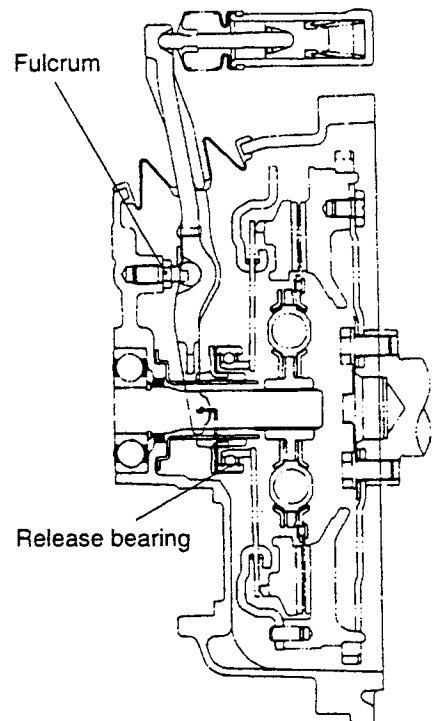
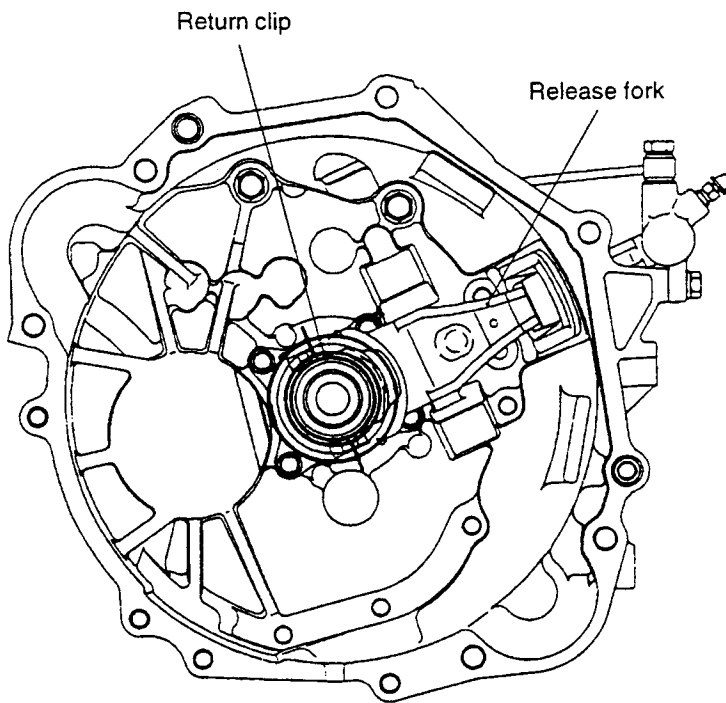

A9FM0061

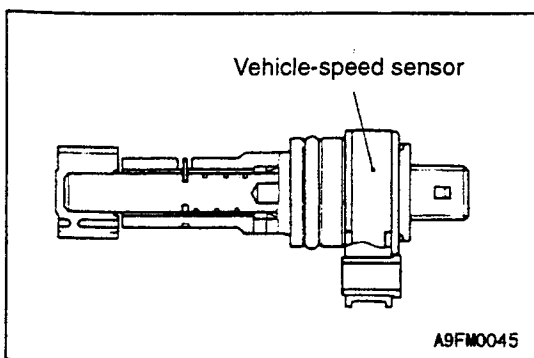

**SPEEDOMETER GEAR**

A speedometer gear with a built-in vehicle-speed sensor has been adopted.

**TRANSMISSION CONTROL**

The following method has been incorporated to reduce the vibration conveyed form the engine transmission.

(1) Bushing is mounted on the transmission side installation section for the shift cable and select cable.

(2) The shift lever side shift cable support section is elastically supported with rubber.

(3) The shift lever bracket is mounted on the floor panel via a damping rubber.

**CONSTRUCTION DIAGRAM**

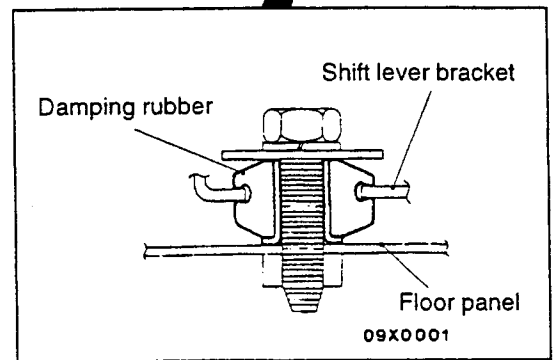
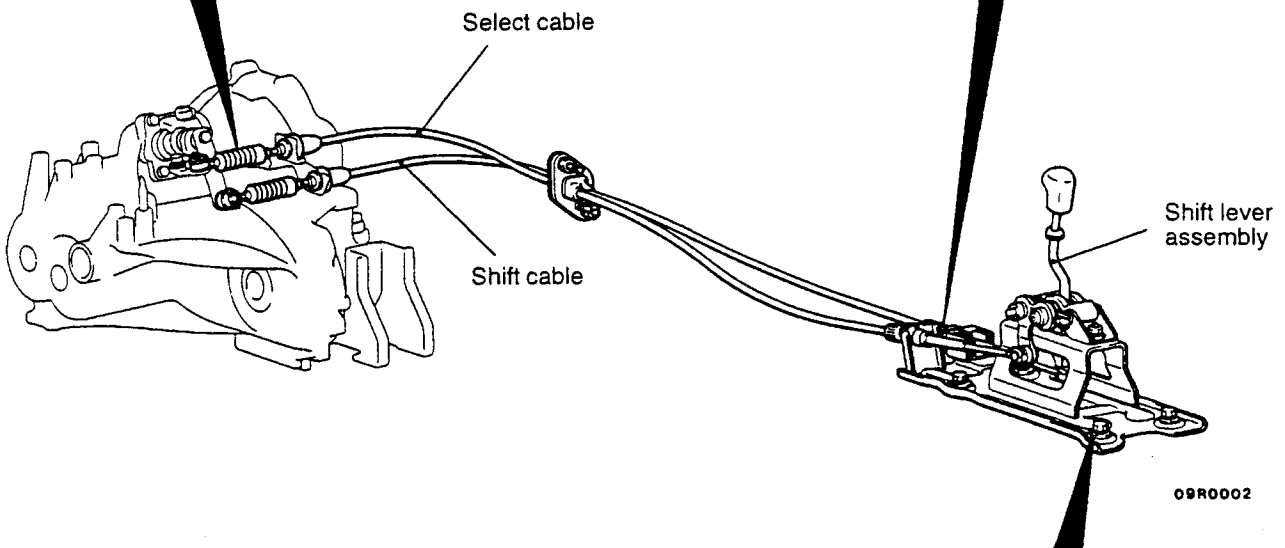
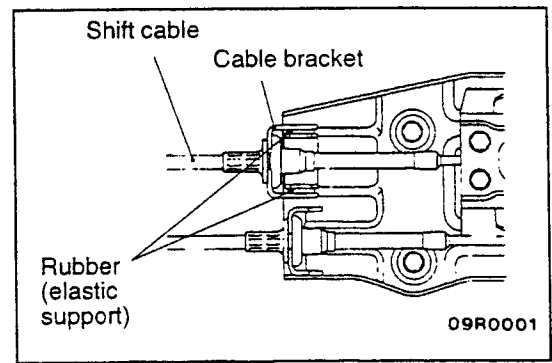
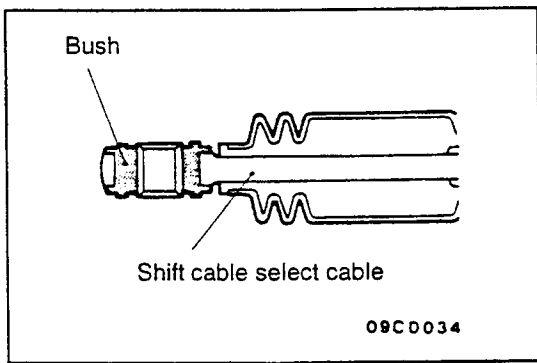

## AUTOMATIC TRANSMISSION

The power train utilizes the newly developed F5A42 automatic transmission – a next-generation system that combines high-grade electronic and mechanical technologies. The new system's key features are as follows:

### Higher commodity value

- (1) Dramatically increased ease of driving thanks to INVECS-II.
- (2) Feedback control and a learning function are utilized in the control of each clutch, thus providing a consistently superior shift feeling.

### Performance improvements

- (1) The clutches utilize a pressure-balanced piston mechanism for crisper gear changes at high speeds.
- (2) A two-shaft layout, increased use of sheet metal components, and the abrogation of a first-gear one-way clutch have resulted in significantly reduced weight.
- (3) Quiet operation is ensured by an increased contact ratio and greater rigidity in the gear supports and case.

## SPECIFICATIONS

Transmission model		F5A42
Engine		6A12
Torque converter	Type	3-element, 1-stage, 2-phase
	Damper clutch	Equipped
	Stall torque ratio	2.0
Transmission type		5-speed forward, 1-speed reverse
Gear ratio	1st	3.789
	2nd	2.057
	3rd	1.421
	4th	1.000
	5th	0.731
	Reverse	3.865
Final gear ratio (differential gear ratio)		3.735
Speedometer gear ratio		30/36
Clutch		Multi-disc type (4 sets)
Brake		Multi-disc type (2 sets), band type (1 set)
Manual control type		P–R–N–D + sport mode (up, down)
Shift pattern		Electronic control (INVECS-II)
Oil pressure control during shifting		Each element independent electronic control + feedback control
Engine-Transmission total control		Equipped
Damper clutch control		Electronic control (full lock-up + partial lock-up)
Self-diagnosis function		Equipped
Fail-safe function		Equipped
Data list function		Equipped
Actuator forced drive function		Equipped

## SECTIONAL VIEW

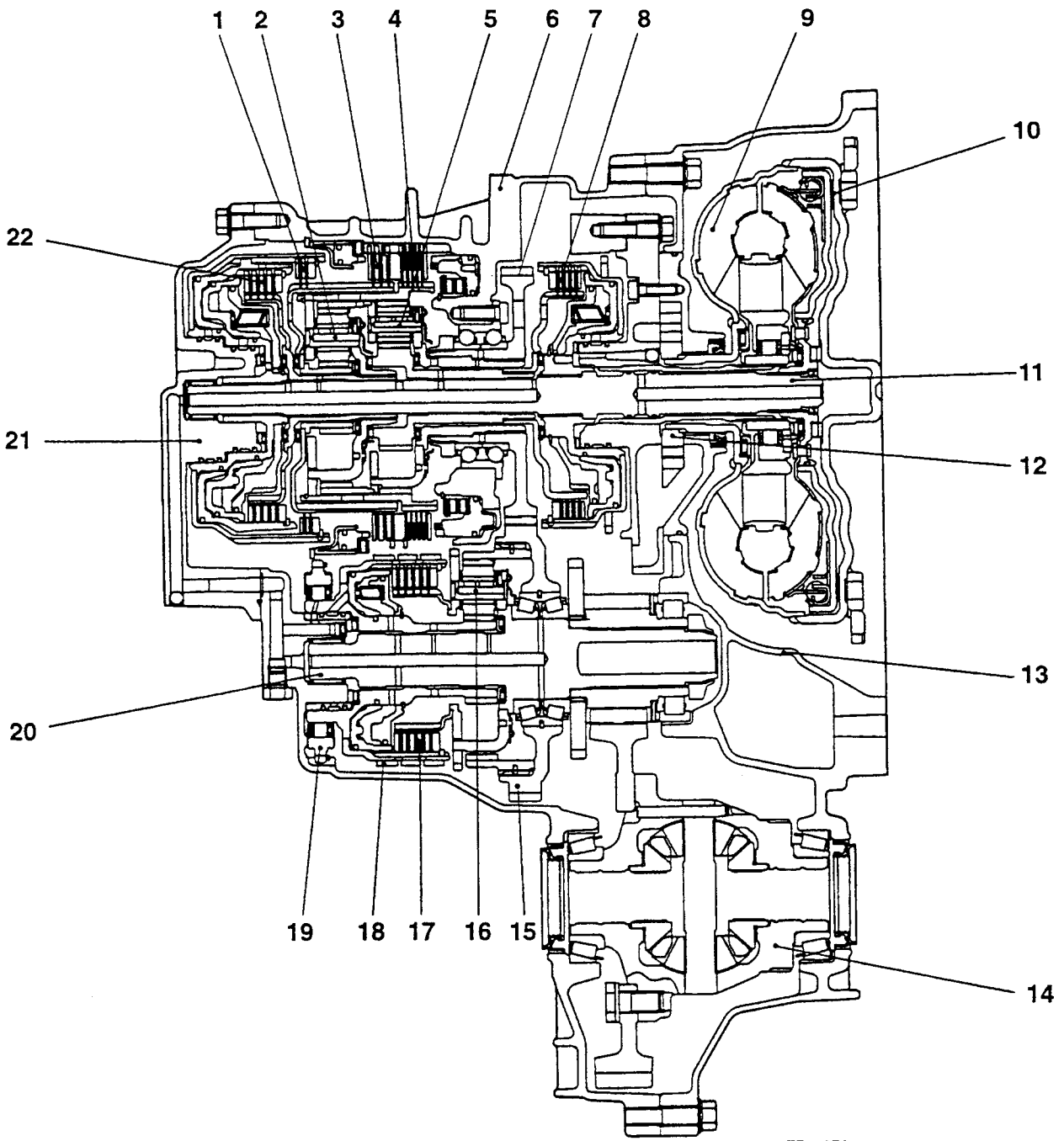

ATFA1970

- |                                 |                               |
|---------------------------------|-------------------------------|
| 1. Reverse clutch               | 12. Oil pump                  |
| 2. Overdrive planetary gear set | 13. Converter housing         |
| 3. Second brake                 | 14. Differential              |
| 4. Low and reverse brake        | 15. Transfer driven gear      |
| 5. Output planetary gear set    | 16. Direct planetary gear set |
| 6. Transmission case            | 17. Direct clutch             |
| 7. Transfer drive gear          | 18. Reduction brake           |
| 8. Underdrive clutch            | 19. One-way clutch            |
| 9. Torque converter             | 20. Output shaft              |
| 10. Damper clutch               | 21. Rear cover                |
| 11. Input shaft                 | 22. Overdrive clutch          |

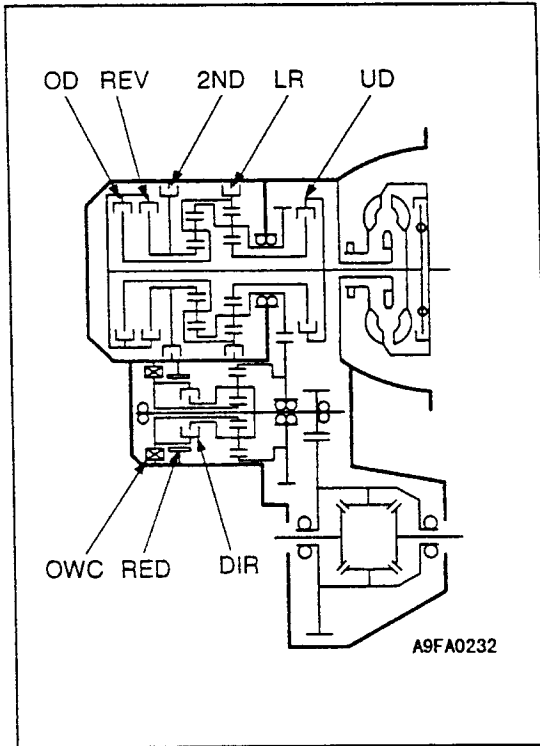

**TRANSMISSION**

- The transmission consists of a torque converter and a gear train.
- The torque converter is a three-element, single-stage two-phase type with a built-in damper clutch.
- The gear train consists of four multiple disc clutch assemblies, two multiple disc brake assemblies, one band type brake assembly, one one-way clutch assembly and three planetary gear assemblies. The planetary gear assemblies consist of sun gears, carriers, annulus gears and pinion gears.

**Number of clutch disc and brake disc**

Operating element	Number
Underdrive clutch disc	4
Reverse clutch disc	2
Overdrive clutch disc	4
Direct clutch disc	5
Low and reverse brake disc	5
Second brake disc	3

**Operating elements and their functions**

Operating element	Symbol	Function
Underdrive clutch	UD	connects the input shaft to the underdrive sun gear.
Reverse clutch	REV	connects the input shaft to the reverse sun gear.
Overdrive clutch	OD	connects the input shaft to the overdrive planetary carrier.
Direct clutch	DIR	connects the direct sun gear to the direct planetary carrier.
Low and reverse brake	LR	holds the low and reverse annulus gear and the overdrive planetary carrier.
Second brake	2ND	holds the reverse sun gear.
Reduction brake	RED	holds the direct sun gear.
One-way clutch	OWC	regulates rotation direction of direct sun gears.

Selector lever positions and operating element

Operating element		Under-drive clutch (UD)	Over-drive clutch (OD)	Second brake (2ND)	Low and reverse brake (LR)	Reverse clutch (REV)	Reduction brake (RED)	Direct clutch (DIR)	One-way clutch (OWC)	
Selector lever position										
P	Parking	-	-	-	○	-	○	-	-	
R	Reverse	-	-	-	○	○	○	-	-	
N	Neutral	-	-	-	○	-	○	-	-	
D	Sport mode	1st	○	-	-	○	-	○	-	○
		2nd	○	-	○	-	-	○	-	○
		3rd	○	○	-	-	-	○	-	○
		4th	○	○	-	-	-	-	○	-
		5th	-	○	○	-	-	-	○	-

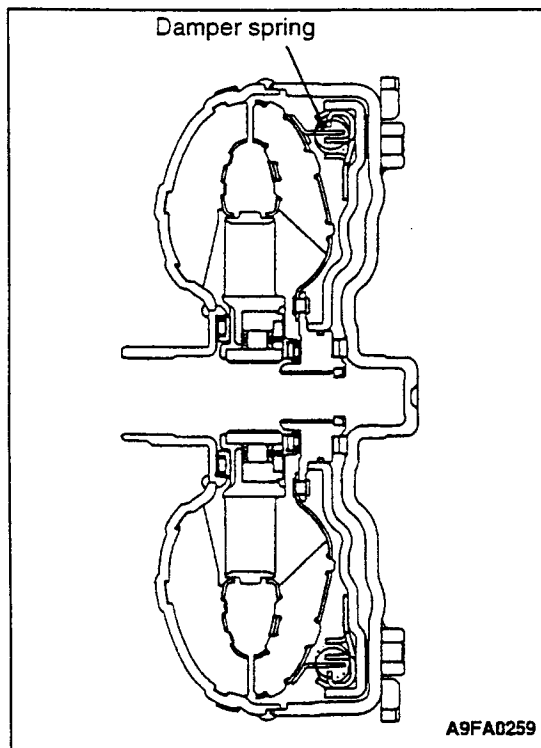

**TORQUE CONVERTER**

The torque converter incorporates a lock-up mechanism with a damper spring. In addition, improvements in damper clutch control and changes in the facing material used result in improved feeling during operation and greater durability.

**TRANSMISSION CASE**

The transmission case components include the converter housing, transmission case, rear cover and valve body cover.

The converter housing, transmission case and rear cover are made from die-cast aluminium to reduce weight. In addition, CAE (Computer Aided Engineering) analysis is utilized to reduce the number of ribs and to optimize their placement,

further contributing to reduced weight and increasing case rigidity. The joining surfaces of the various cases use liquid-type gaskets (FIG) to improve productivity and sealing performance.

In addition, the names of the hydraulic pressure check ports are embossed near each port to make checking of the hydraulic pressure easier.

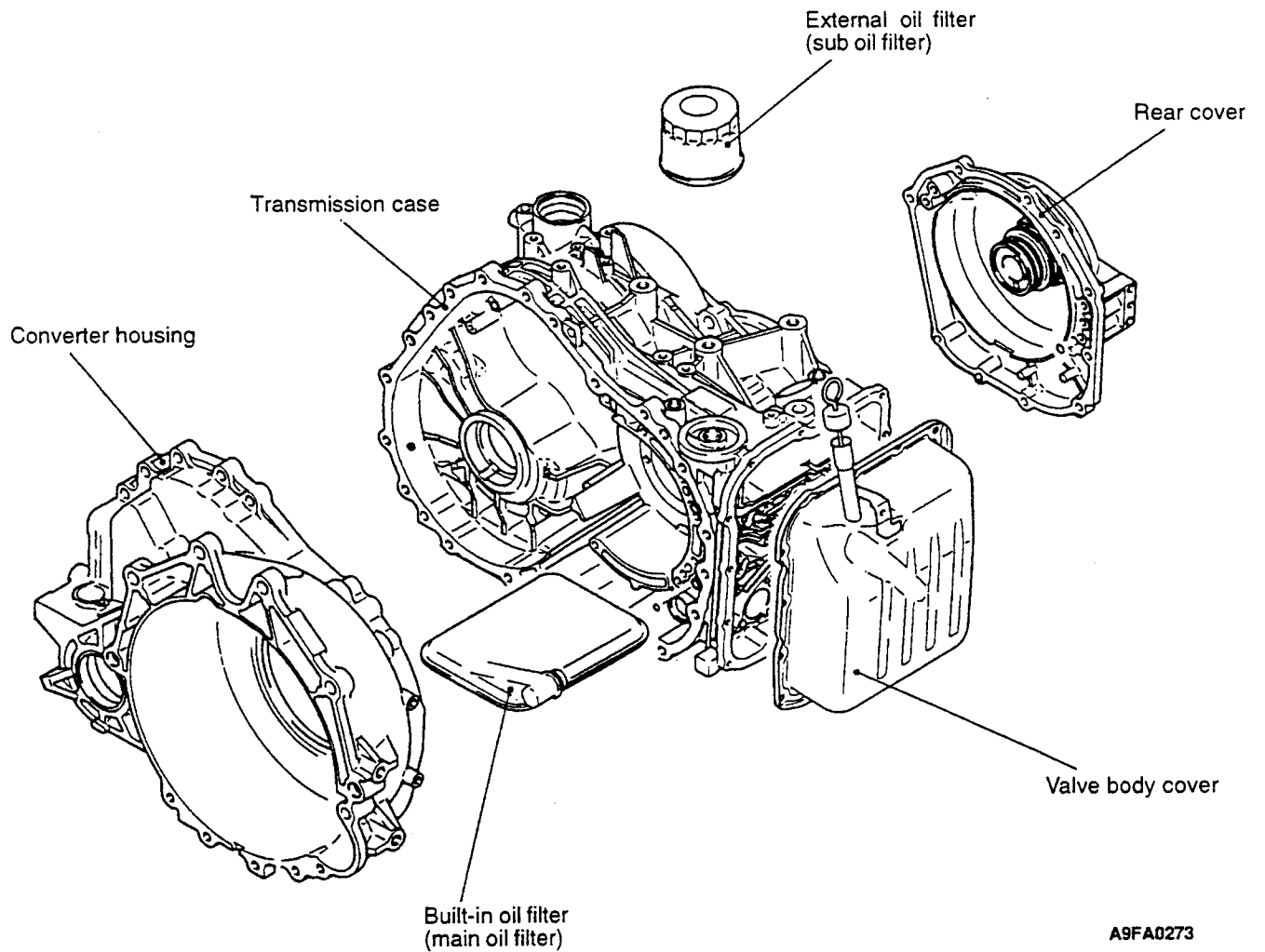

A9FA0273

### CLUTCH

The gear shifting mechanism consists of four multiple disc clutch assemblies and one one-way clutch assembly. Precision sheet metal plates are used as the retainers for each clutch to increase effectiveness and also to reduce weight. Furthermore, a hydraulic balancing mechanism which cancels out centrifugal hydraulic pressure has been adopted in place of the piston check ball which was used previously in order to handle increased engine speeds.

#### Underdrive clutch

The underdrive clutch operates in 1st, 2nd, 3rd and 4th gear to transmit the drive force from the input shaft to the underdrive sun gear. The underdrive clutch mechanism consists of the parts shown in the illustration at left. The pressure of the transmission fluid acts between the piston and the retainer (piston hydraulic pressure chamber) to move the piston, and the piston pushes against the clutch disc to transmit the drive force from the retainer to the hub.

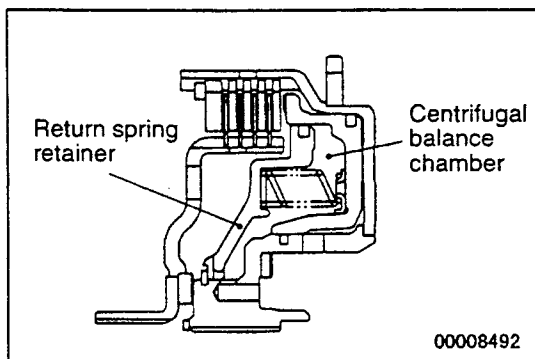
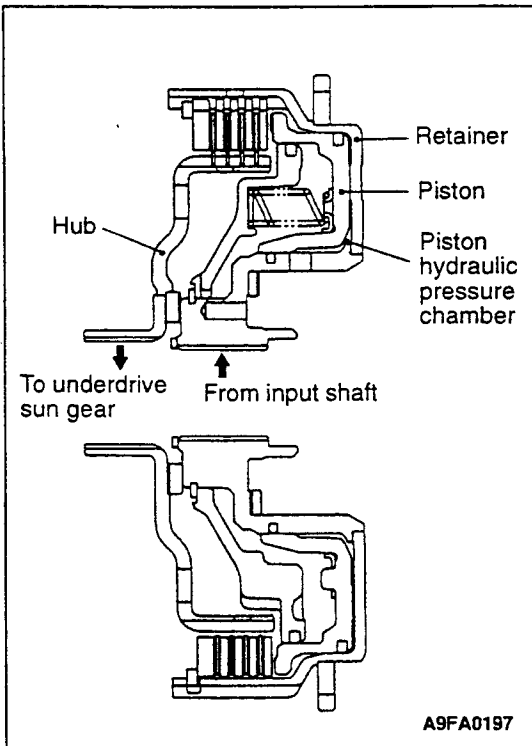

When the engine is running at high speed, the transmission fluid remaining in the piston hydraulic pressure chamber is subjected to centrifugal force and pushes against the piston, but the piston does not move because the fluid which fills the centrifugal balance chamber (between the piston and the return spring retainer) also generates centrifugal force which pushes back the piston, and both forces cancel each other out.

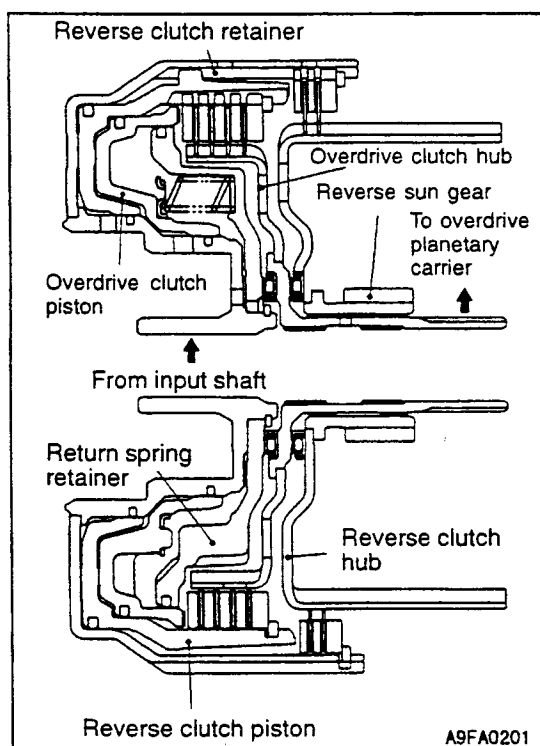

#### Reverse clutch, overdrive clutch

The reverse clutch operates in reverse gear to transmit the drive force from the input shaft to the reverse sun gear. The overdrive clutch operates in 3rd, 4th and 5th gears to transmit the drive force from the input shaft to the overdrive planetary carrier and to the low and reverse annulus gears. The reverse clutch and overdrive clutch consist of the parts shown in the illustration at left. The clutch retainer of the overdrive clutch also functions as the reverse clutch piston. The hydraulic pressure of the reverse clutch is applied between the reverse clutch retainer and overdrive clutch retainer to move the overdrive clutch assembly and transmit the pressure from the retainer to the hub.

In the same manner, the overdrive clutch hydraulic operation is applied between the piston and retainer to transmit the drive force from the retainer to the hub.

Furthermore, the effect of the centrifugal force on both clutches is eliminated by the hydraulic pressure balance mechanism on the inner side of the overdrive clutch piston.



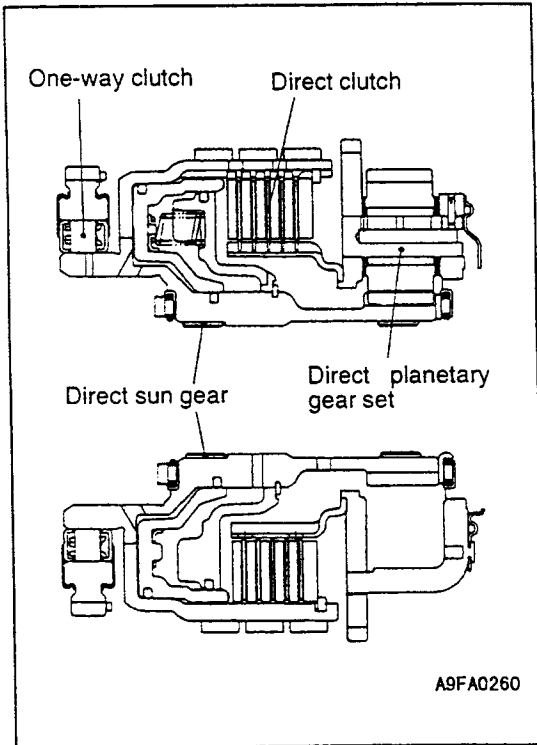

**Direct clutch**

The direct clutch is applied in the 4th and 5th speeds, and connects the direct planetary gears and direct sun gears. The direct clutch consists of the parts shown in the illustration at left. The hydraulic pressure is applied between the piston and retainer to transmit the drive force from the retainer to the hub when the piston presses against the clutch disc.

**One-way clutch**

A sprag type one-way clutch is incorporated. This is applied in the 1st, 2nd and 3rd gears and limits the rotation direction to one direction. When the speed varies, the direct pinion turns in counterclockwise, so this clutch stops the direct sun gears from turning in clockwise.

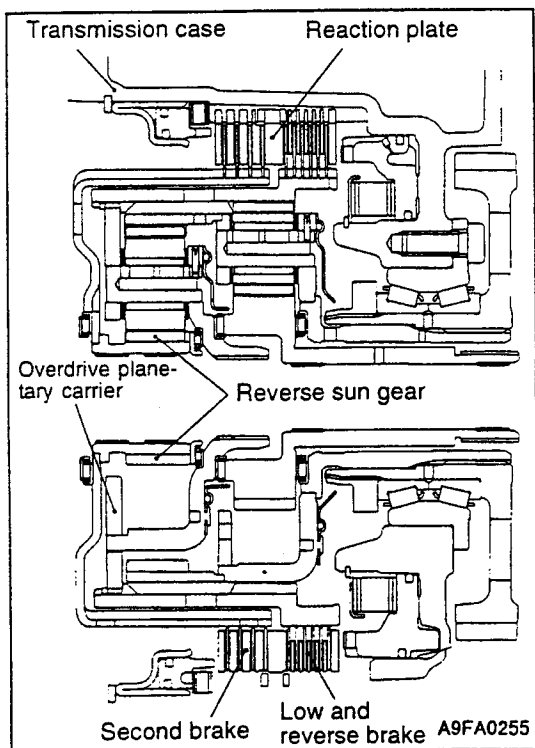

**BRAKE**

Two multiple disc brake assemblies and one band type brake assembly are used.

**Low and reverse brake, second brake**

The low and reverse brake is applied in 1st or reverse gear or when shifting lever is at P or N to stop the low and reverse annulus gears and the overdrive planetary carrier to the case. The 2nd brake is applied in 2nd and 5th gear to stop the reverse sun gear at the case.

The low and reverse brake consists of the parts shown in the illustration at left. The discs and plates for each brake are positioned on both sides of the reaction plates which are secured to the case by snap rings.

The hydraulic pressure of the second brake is applied between the retainer and piston. The piston is moved to generate force by pressing against the brake disc, and link the case and hub.

In the same manner, the hydraulic pressure of the low and reverse brake is applied between the case and piston to move the piston and link the case and hub.

A wave type coil spring is incorporated for the return spring of both brakes.

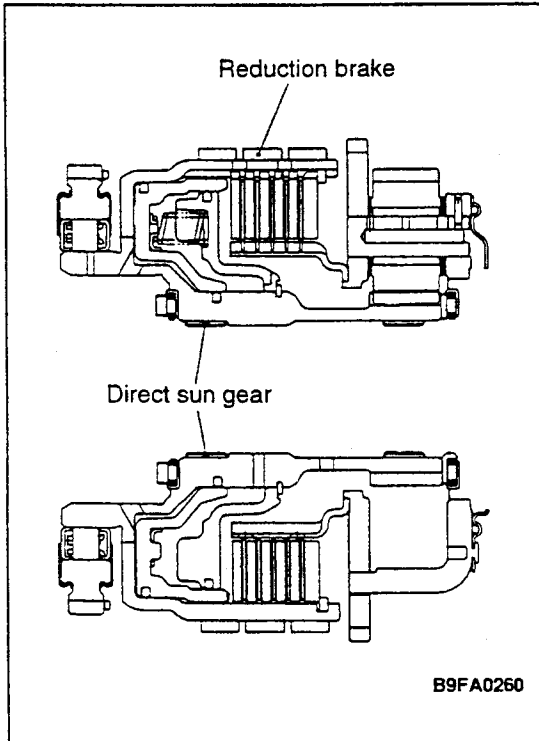

### Reduction brake

The reduction brake is applied in 1st, 2nd, 3rd or reverse gear or when shifting lever is at P or N to stop the direct sun gears and the overdrive planetary carrier to the case. The consists of the parts shown in the illustration at left. A structure that tightens the band by the reduction brake piston is incorporated.

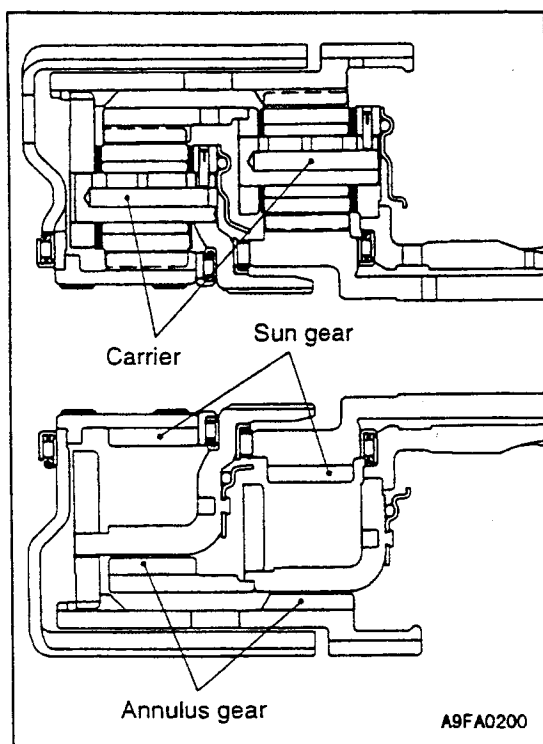
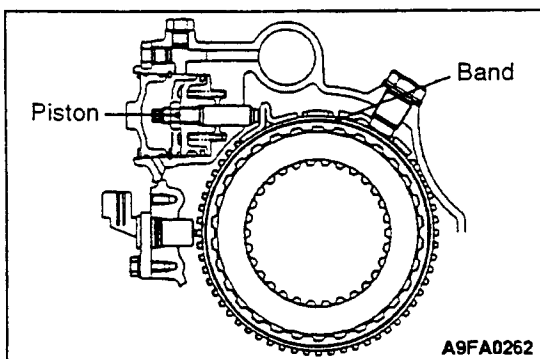

### POWER TRAIN

#### Planetary gear set (overdrive planetary gear, output planetary gear)

A planetary gear set configured of a combination of two planetary gear sets is incorporated on the input shaft side. The primary gear ratio is produced by mechanically linking one carrier with another annulus gear, and by linking and fixing the carrier and sun gear.

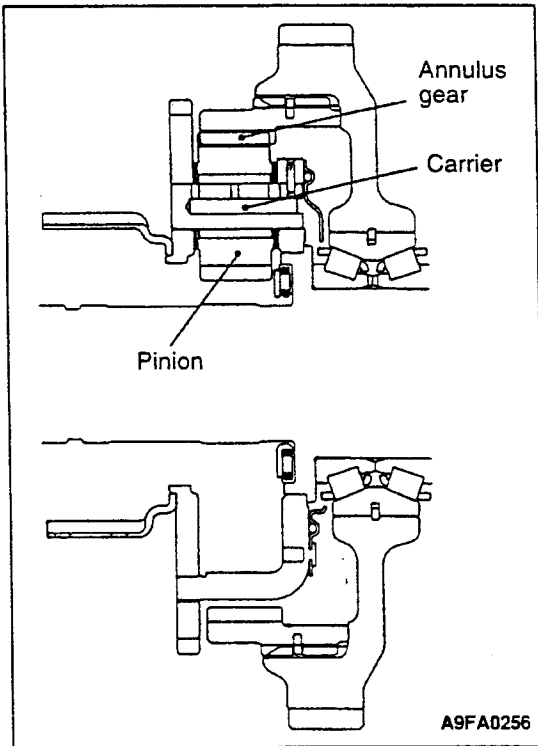

**Direct planetary gear**

One set of planetary gears are incorporated on the output shaft side. The secondary gear ratio is produced by linking and fixing the carrier and sun gear.

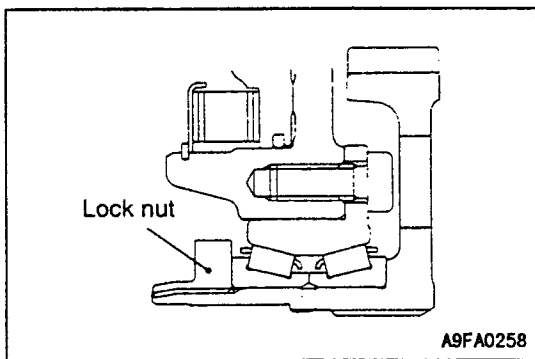

**Transfer drive gear**

The compact size, modular structure and longer gear teeth result in improved meshing efficiency and reduced gear noise. In addition, the bearing which supports the drive gear is a preload type of bearing so that play is eliminated. The bearing is also bolted directly to the case to increase the rigidity of the gear.

**Differential**

The 6.1 differential has been incorporated for the differential.

POWERFLOW

1st gear

The underdrive clutch, low and reverse brake, reduction brake and one-way clutch are applied when in 1st gear. The drive force from the input shaft is transmitted via the underdrive clutch to the underdrive sun gear. The drive force which is transmitted to the underdrive sun gear is then transmitted through the output pinion and tries to turn the low and reverse annulus gear counterclockwise. In addition, the output pinion orbits around the underdrive sun gear to turn the output planetary carrier clockwise.

Because the low and reverse brake is also applied at this time, the low and reverse annulus gear is fixed in place and only the output planetary carrier turns clockwise. This drive tries to turn the direct pinion counterclockwise via the transfer drive gear

and transfer driven gear. As the direct sun gear is fixed by the one-way clutch, the direct pinion tries to turn the direct planetary carrier clockwise in a way that revolves around the direct sun gear. As the direct planetary carrier is linked with the output shaft, the output shaft turns clockwise and produces the 1st gear ratio.

Then because the output planetary carrier is linked to the output annulus gear, the overdrive pinion gear also moves at the same time, but because the overdrive planetary carrier is fixed in place by the low and reverse brake and the reverse sun gear is turning freely, the turning of the overdrive pinion gear has no effect on the output planetary carrier.

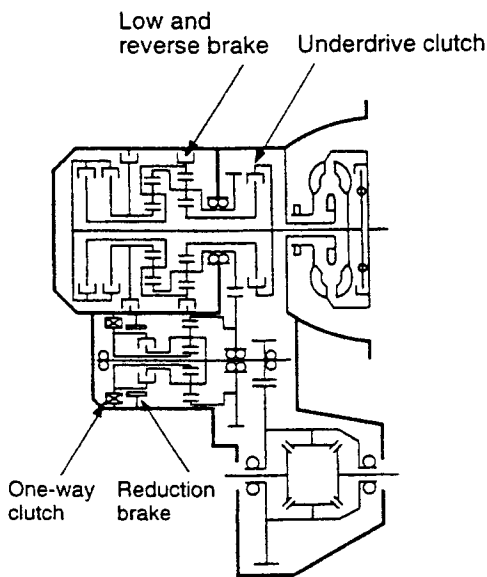

9FA0232

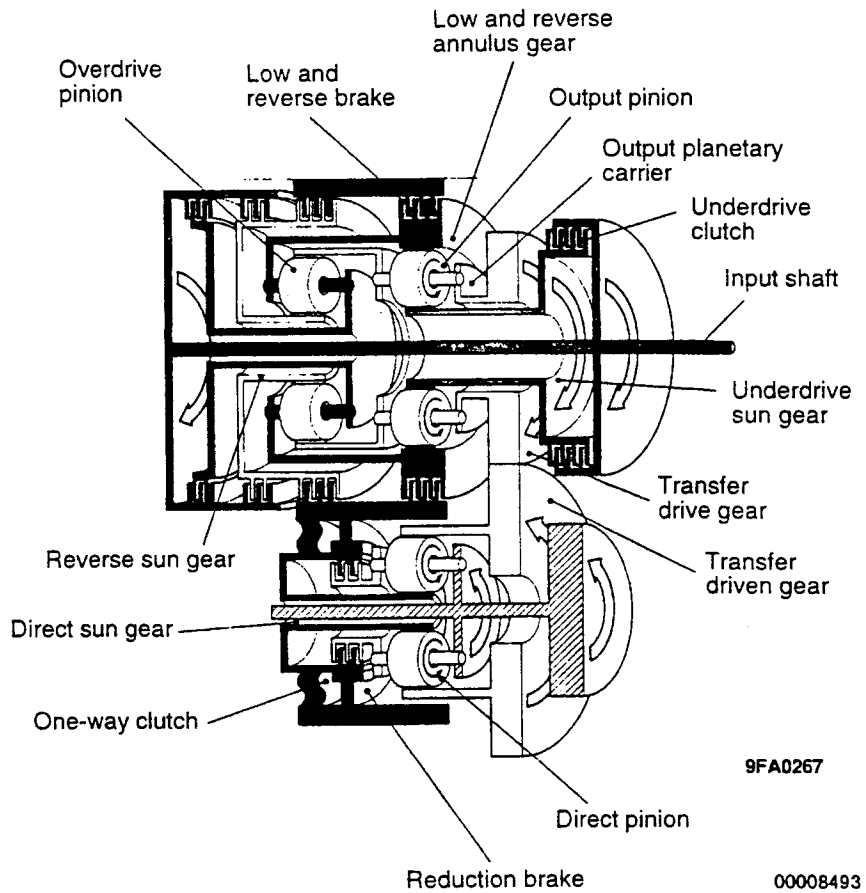

9FA0267

00008493

**2nd gear**

The underdrive clutch, 2nd brake, reduction brake and one-way clutch are applied when in 2nd gear. From the situation in 1st gear, when the 2nd brake is applied and the low & reverse brake is released, the reverse sun gear is stopped and the drive force from the output annulus gear causes the overdrive pinion to orbit around the reverse sun gear, and the overdrive planetary carrier turns clockwise. Because the overdrive planetary carrier is linked to the low and reverse annulus gear, the low and

reverse annulus gear also turns clockwise. The rotation of the low and reverse annulus gear is transmitted to the transfer drive gear and transfer driven gear via the output pinion. However, as there is no element change from the 1st gear of the output shaft side, the rotation amount of the low and reverse annulus gear is added to the amount of rotation of the output planetary gear to product the gear ratio for the 2nd gear.

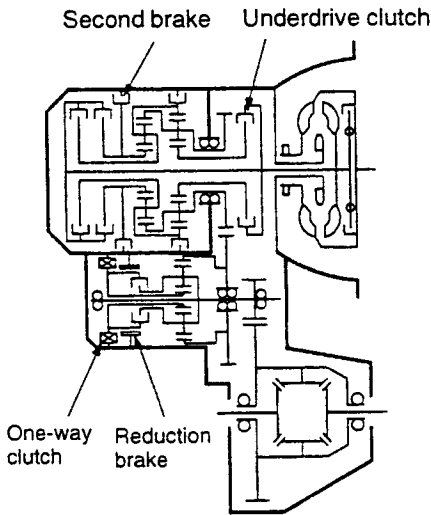

9FA0232

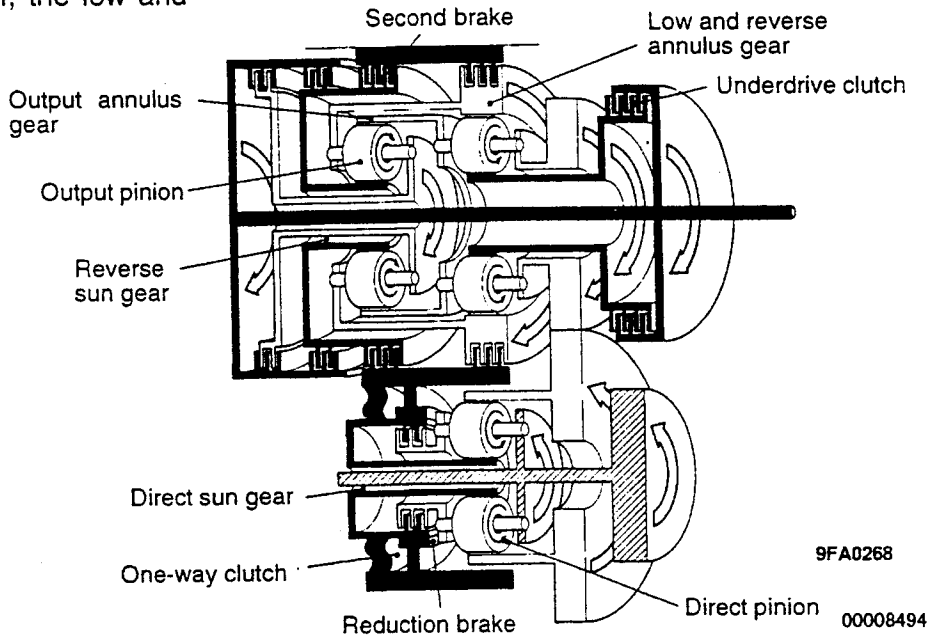

9FA0268

0008494

**3rd gear**

The underdrive clutch, overdrive clutch, reduction brake and one-way clutch are applied in 3rd gear. Because the overdrive clutch is connected to the input shaft and to the overdrive planetary carrier and the low and reverse annulus gear, the turning speed of the underdrive sun gear, which is linked to the input shaft via the underdrive clutch, becomes the same as the turning speed of the low and

reverse annulus gear. The planetary gear set turns in an integrated locked state and transmits the drive force to the transfer driven gear via the transfer drive gear. As the element function of the output shaft side is the same as 1st gear, the planetary gear set turns in an integrated locked state to produce the gear ratio of the 3rd gear.

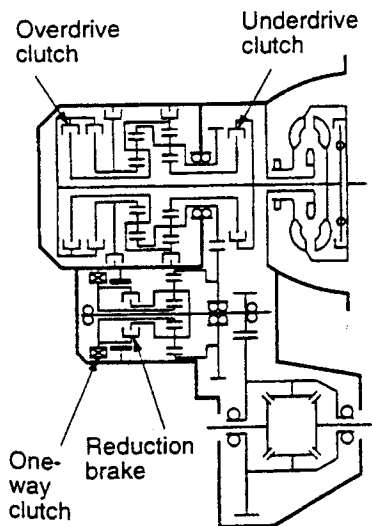

9FA0232

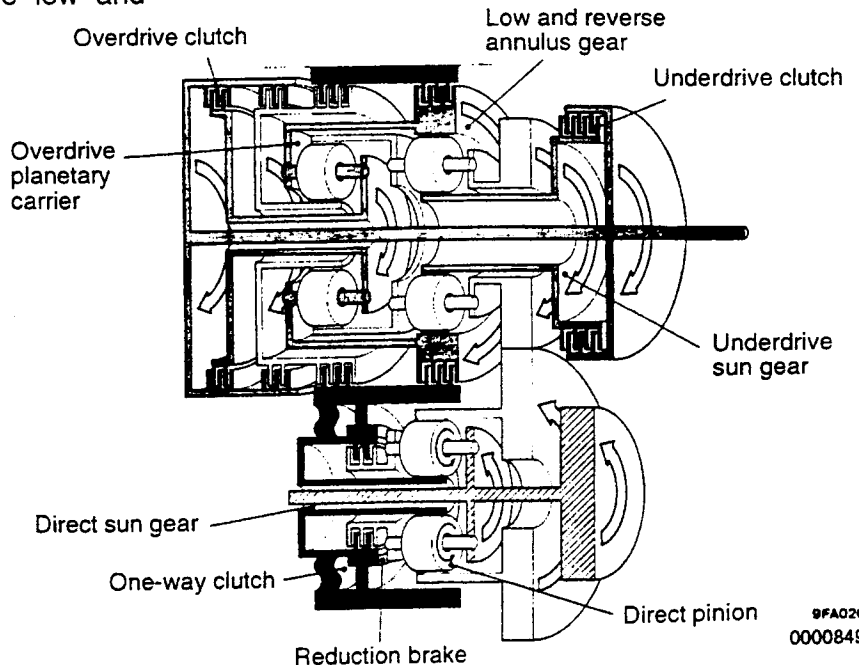

9FA0269

0008495

**4th gear**

The underdrive clutch, overdrive clutch and direct clutch are applied in 4th gear. The input shaft side element function state is the same as the 3rd gear in that the planetary gear set turns in an integrated state. The drive force input in the transfer driven gear tries to turn the drive sun gear counterclockwise via the direct pinion

from the linked direct annulus gear. On the other hand, as the direct sun gear is lined to the direct planetary carrier and output shaft by the direct clutch, integrated counterclockwise turning occurs to produce the gear ratio of the 4th gear.

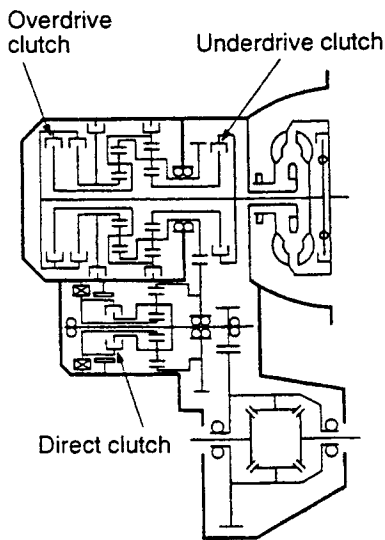

9FA0232

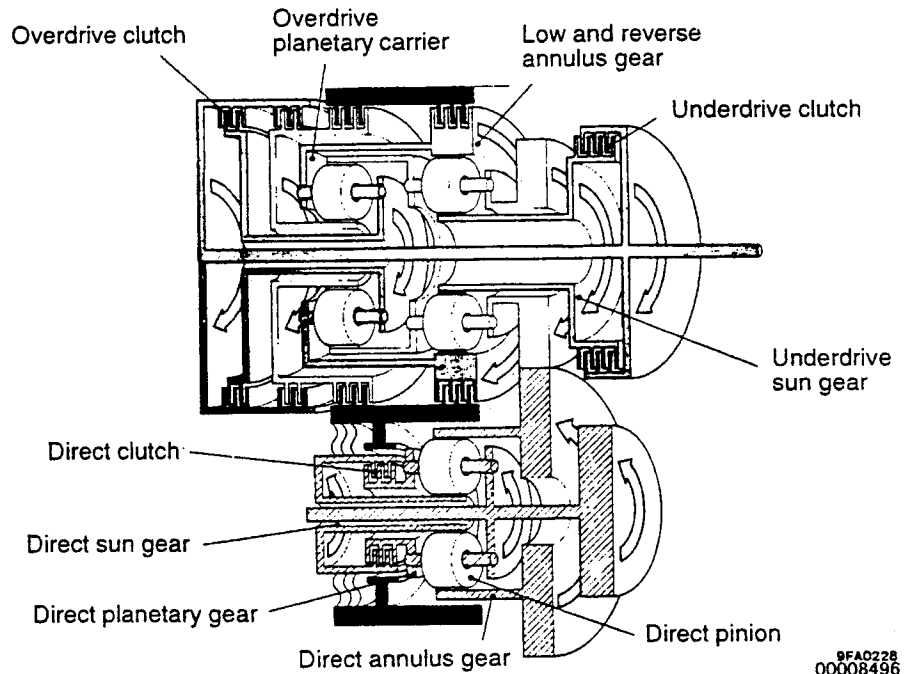

9FA0228  
00008496

**5th gear**

The overdrive clutch, direct clutch and the second brake are applied in 5th gear. The drive force from the input shaft is transmitted via the reverse clutch to the overdrive planetary carrier. As the reverse sun gear is fixed by the second brake, the speed obtained by adding the amount of revolution around the reverse sun gear of the overdrive pinion to the amount of rotation

of annulus gear. This drive force is transmitted to the transfer driven gear via the output planetary carrier and transfer drive gear linked with the overdrive planetary carrier. As the output shaft side function element is the same as the 4th gear, the gear ratio of the 5th gear is produced by the revolution of the overdrive pinion.

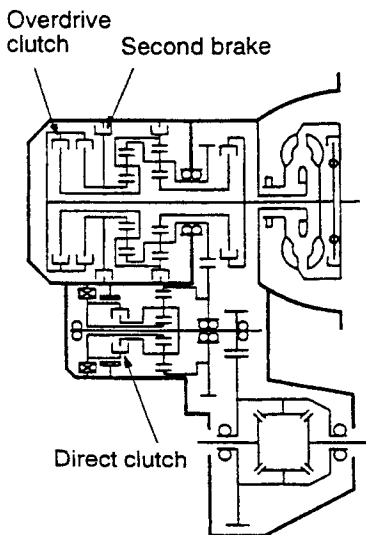

9FA0232

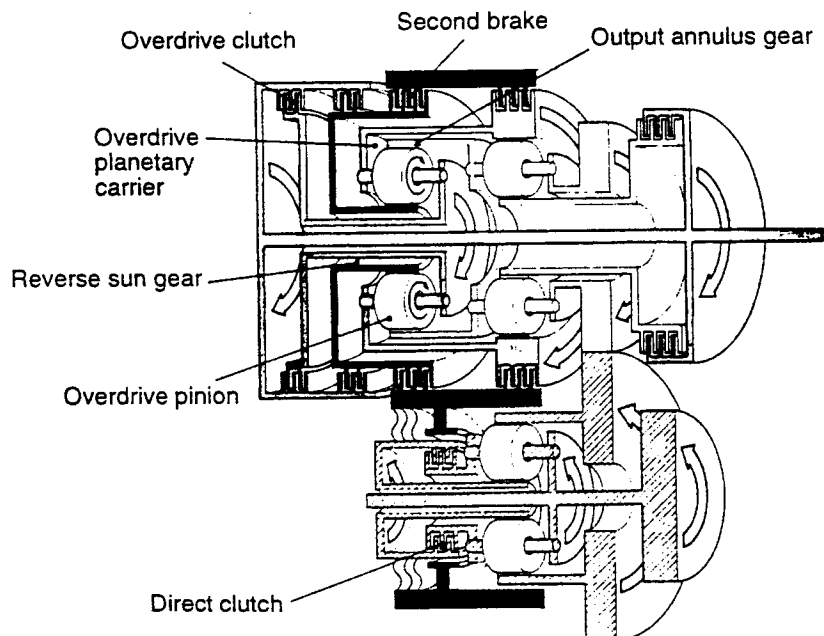

9FA0229  
00008497

Reverse

The reverse clutch, low and reverse brake and reduction brake are applied in R range. The drive force from the input shaft is transmitted via the reverse clutch to the reverse sun gear. On the other hand, because the overdrive planetary carrier is stopped by the low and reverse brake, the drive force from the reverse sun gear is transmitted via the overdrive pinion to the output annulus gear as a force which rotates the output annulus gear counterclockwise. This drive force is transmitted to the transfer driven gear via the

output planetary carrier and transfer drive gear. As the direct sun gear is fixed by the reduction brake, the amount of revolution around the direct sun gear of the direct pinion is added to turn the direct planetary carrier clockwise and product the gear ratio for the R range. In addition, the output pinion is also forced to turn by the output planetary carrier, but because the underdrive sun gear is turning freely, the turning of the output pinion has no effect on the turning of the output planetary carrier.

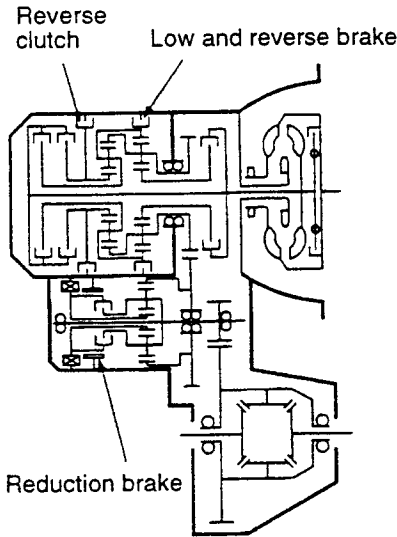

9FA0232

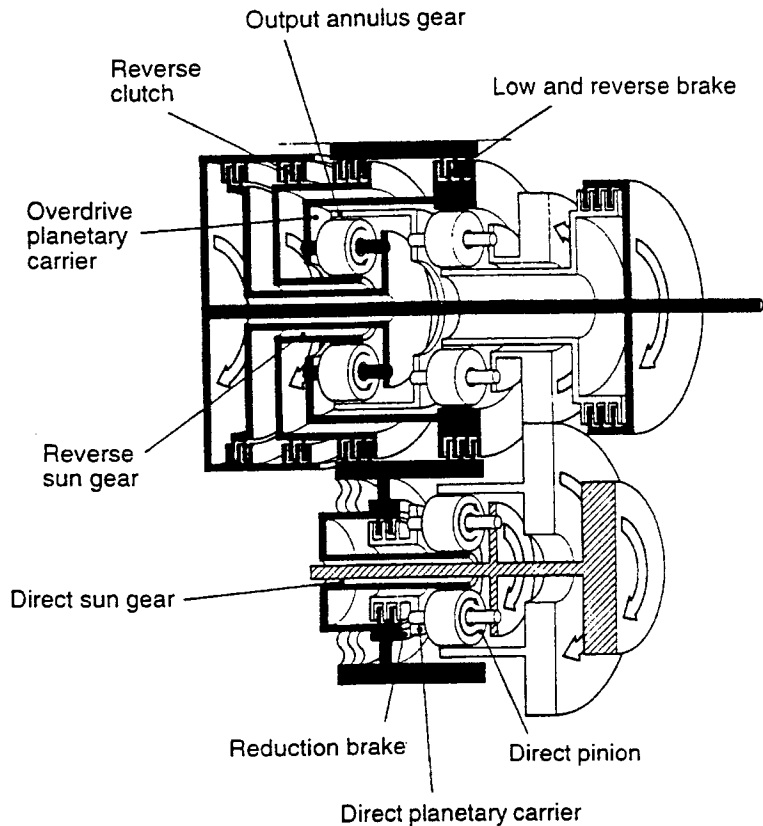

9FA0270  
00008498

**Park and Neutral**

Because all input clutches are released in P and N ranges, the drive force from the input shaft is not transmitted to the planetary gears.

However, the low and reverse brake and the reduction brake are applied as a preparatory measure to make shifting to 1st gear or reverse quicker.

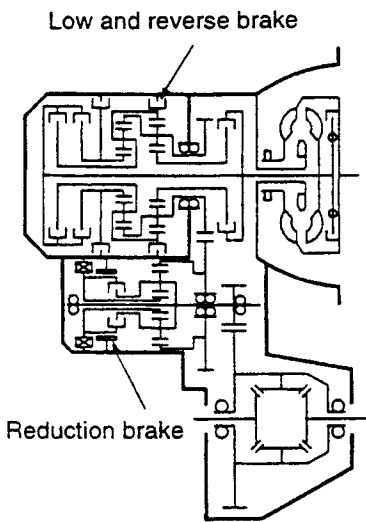

9FAO232

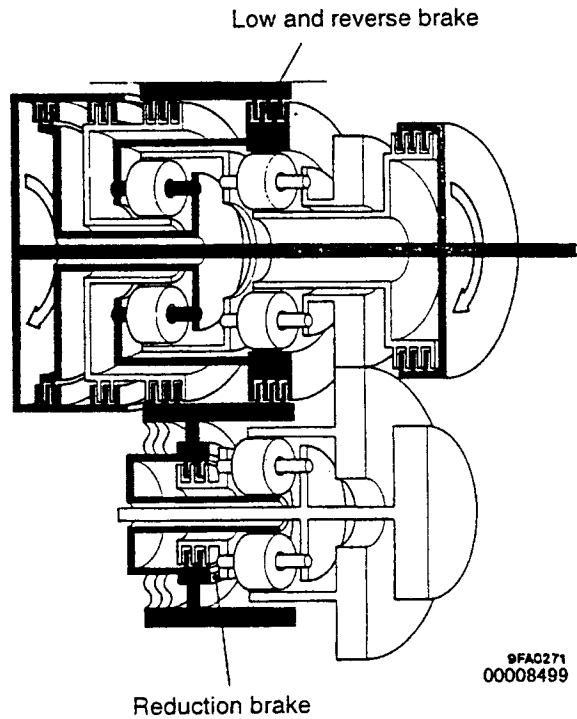

9FAO271  
00008499

**MANUAL CONTROL SYSTEM**

**Manual control lever**

The manual control lever is mounted at the top of the valve body and is connected to the parking roller rod and the manual control valve pin.

In addition, a detent mechanism is also provided to improve the shift feeling during manual selection.



**Parking mechanism**

When the manual control lever is moved to the P position, the parking roller rod moves along the parking roller support and the parking sprag is raised.

This causes the parking sprag to mesh with the parking gear of the transfer driven gear to stop the output shaft from turning. The end of the rod is equipped with a roller to reduce the operation effort for parking.

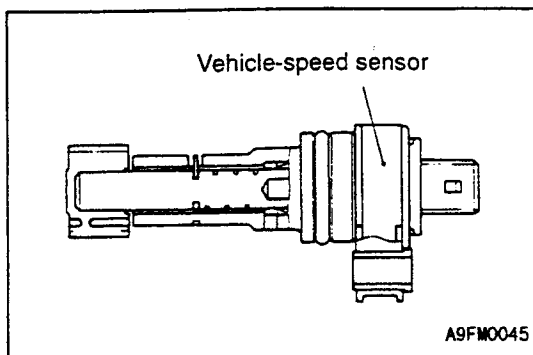
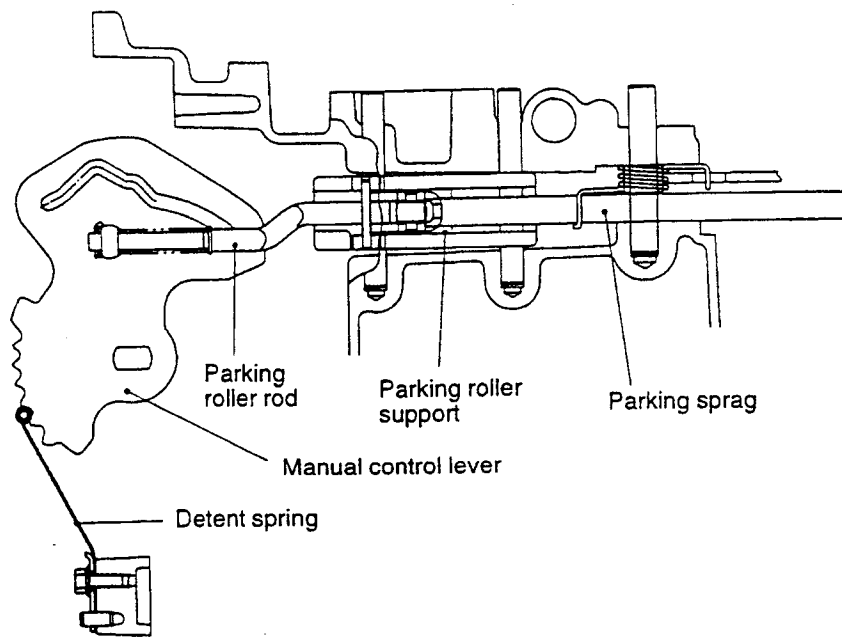
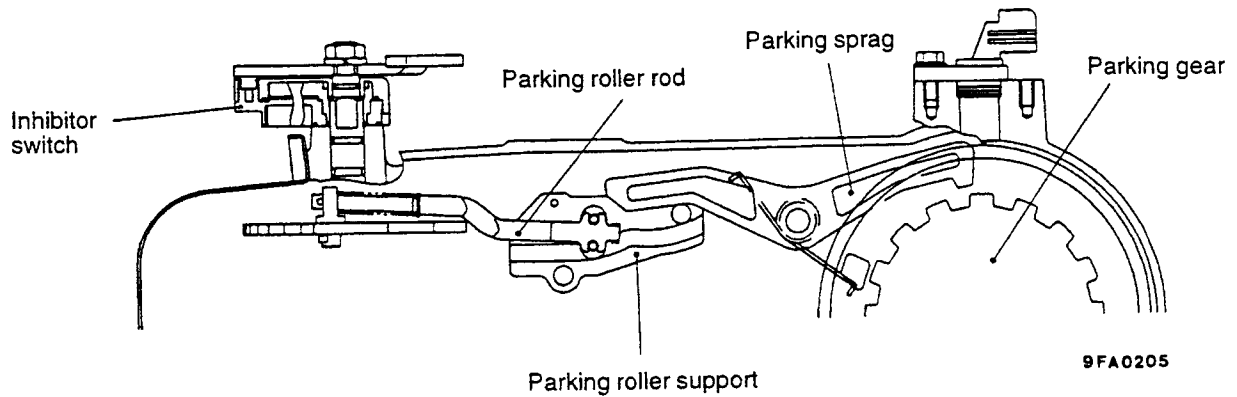

**Speedometer gear**

A speedometer gear with vehicle-speed sensor built in is incorporated.

HYDRAULIC CONTROL SYSTEM

- The hydraulic control system consists of the following components: an oil pump which generates the hydraulic pressure, a regulator valve which controls the generated pressure so it is at the specified level, solenoid valves which convert the electronic signals from the A/T-ECU to the equivalent hydraulic pressure, pressure control valves which control the hydraulic pressure applied to each clutch and brake based on the hydraulic pressures from the solenoid valve, valves which receive the hydraulic line pressure and switch over the pressure route, and a valve body which houses these valves.
- The fluid pressures for each clutch and brake during gear shifting are controlled independently and electronically by means of the solenoid valves which are provided at each clutch and brake. This ensures smooth and highly-responsive shifting.
- Two oil filters are used to improve filtering performance. In addition, a newly-developed automatic transmission fluid has been used which eliminates the need to periodically replace the fluid.
- The outlet ports of each valve have been combined into one port (the No.25 port), and a check ball is installed at the end of the outlet line. These measures prevent the automatic transmission fluid from draining away from the valve body and the clutches and brakes while the engine is stopped.
- A switch valve and fail-safe valves make it possible to continue driving in 3rd gear or R range event if a problem occurs in the electronic control system.

Hydraulic Circuit (Neutral)

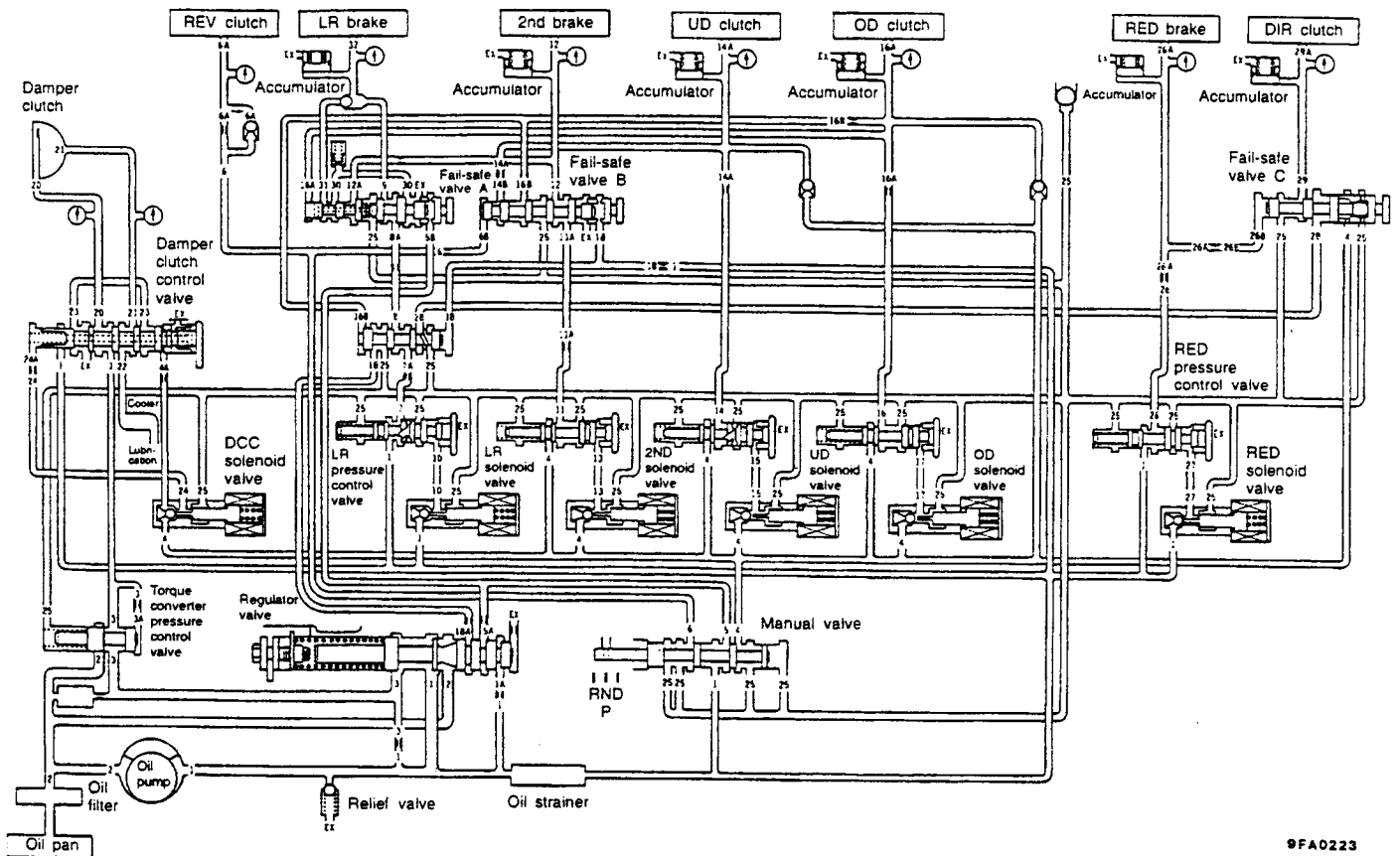

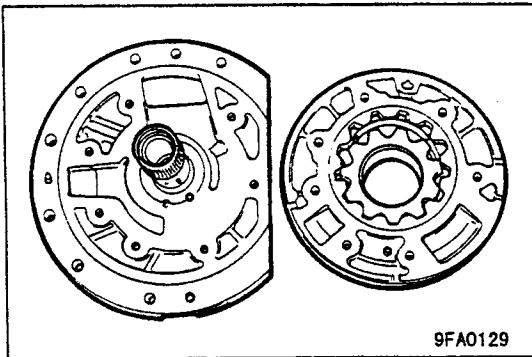

9FA0129

### OIL PUMP

- A trochoid type pump is used.
- The oil pump housing is made from die-cast aluminium to reduce weight and to save space.
- Spare parts of the oil pump are supplied in assembly form.

### VALVE BODY

- The valve body is mounted laterally at the front of the vehicle beside the A/T. This reduces the overall height of the A/T.
- The valve body comprises an inside and outside section, and part of the hydraulic line is located at the side of the A/T case.
- Solenoid valves and pressure control valves are provided for each clutch and brake to

simplify the hydraulic circuit, while also reducing the number of different types of valves.

- Adjustment of line pressure is carried out by a regulator valve.
- A switch valve and fail-safe valves make it possible to continue driving in 3rd gear or R range even if there is a malfunction of a solenoid valve.

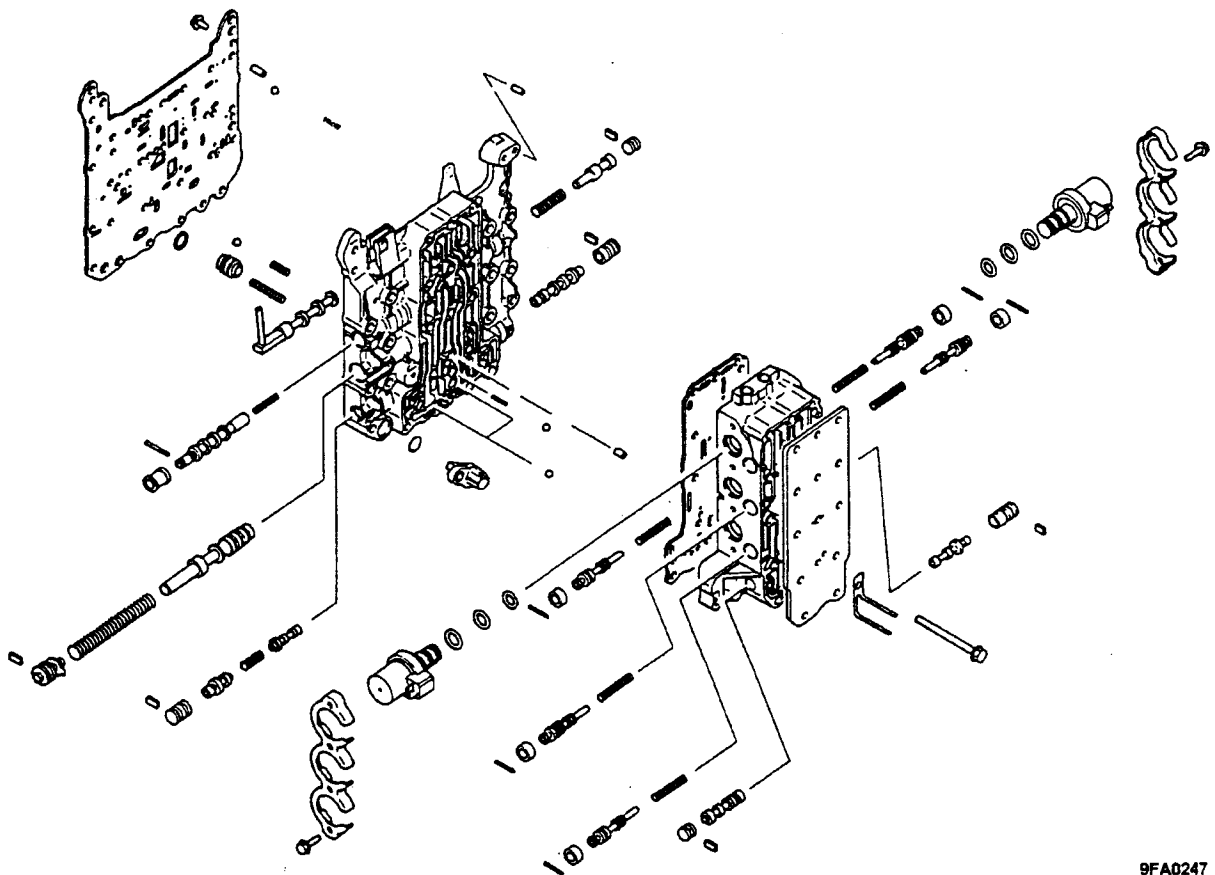

9FA0247

### Regulator valve

The regulator valve adjusts the hydraulic pressure generated by the oil pump so that it is the same as the line pressure. The line pressure is applied to three ports (1A, 5A and 18A) which are located at the right side of this valve. Those hydraulic pressures work against the force of the spring to adjust the line pressure to the pressures corresponding to each shifting stage.

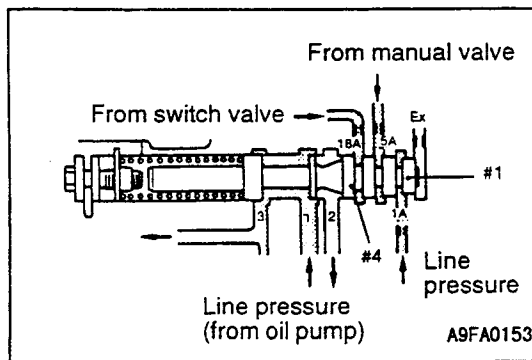
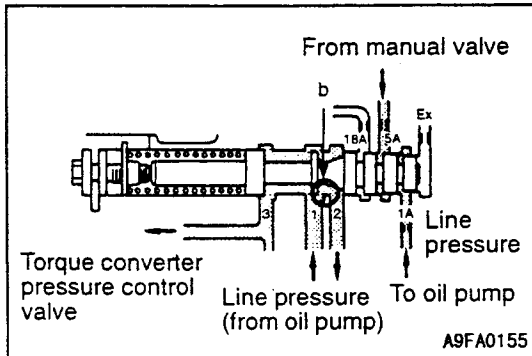
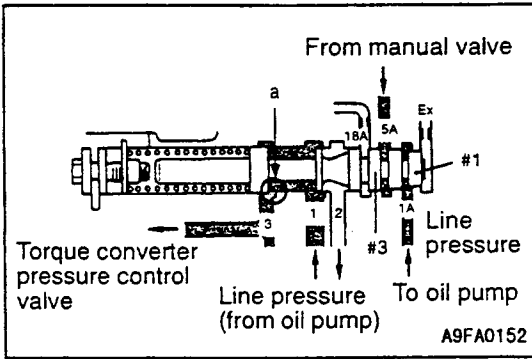

### [Operation]

#### (1) Neutral, 1st and 2nd gear

The hydraulic pressure from the oil pump is supplied to the regulator valve through No.1 and No.1A ports. The hydraulic pressure which is supplied through the No.1 port is then sent from the No.3 port via the torque converter pressure control valve to the torque converter. The line pressure which passes through the manual valve is sent to the regulator valve from the No.5A port.

When line pressure is supplied to the No.1A and No.5A ports, the difference in area between the No.1 land and the No.3 land generates a force which pushes the valve to the left. This force and the force from the spring which pushes the valve to the right work together to adjust the line pressure. The speed of the oil pump increases as the engine speed increases, and this in turn increases the hydraulic pressure. As the pressure increases, the hydraulic pressure applied to the No.1A and No.5A ports also increases. When the pressure becomes higher than the force of the spring, the valve is pushed to the left. This increases the size of the path a to the torque converter, and a higher volume of fluid is supplied to the torque converter.

As the pressure becomes greater, the valve is pushed further to the left until the path b to the No.2 port is opened. When this occurs, the pressure escapes back to the oil pump and the line pressure drops.

When the line pressure drops, the pressure applied to the No.1A and No.5A ports also drops. The valve is then pushed to the right as a result of force from the spring, and path b closes. In this way, the line pressure is kept at a constant pressure.

The line relief valve which is provided in the No.1 line opens in case the line pressure becomes greater than the regulating pressure at the regulator valve. This allows pressure to escape to preserve the hydraulic circuit.

#### (2) 3rd, 4th and 5th gears

Line pressure is supplied through the No.18A port as well as through the No.1A and No.5A ports. The force which pushes the valve to the left as a result of this is equal to the difference in area between the No.1 land and the No.4 land.

Because the area of the No.4 land is greater than that of the No.3 land, the force which pushes the valve to the left is greater than in (1) above, even though it is being acted on by the same pressure.

Accordingly, because port b is opened by a pressure which is lower than that in (1), the line pressure only decreases by the amount that this pressure is higher.

The regulator valve operates in the same way as in (1) when the line pressure increases.

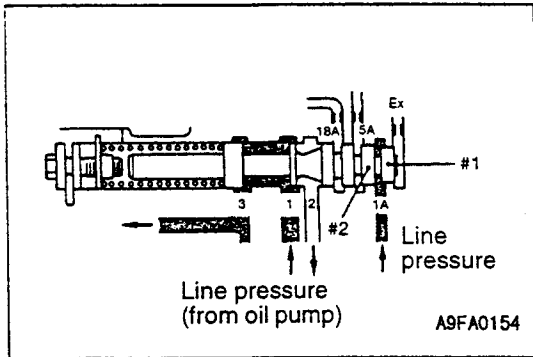

**(3) Reverse**

When the manual valve is in the R range, the route to the No.5 port is closed, and thus, the line pressure is not supplied to the No.5A port. Due to this, the force which presses the valve to the left is the difference between the areas of the No.1 and the No.2 land.

Because the area of the No.2 land is smaller than the area of the No.3 land, the force which pushes the valve to the left is smaller than in (1), even though it is being acted on by the same pressure.

Accordingly, because port b will not open if the pressure is not higher than in (1), the line pressure only increases by the amount that this pressure is higher.

In this way, the high line pressure that is necessary for the operating elements is generated in R range.

The regulator valve operates in the same way as in (1) when the line pressure increases.

**Torque converter pressure control valve**

- The torque converter pressure control valve adjusts the hydraulic pressure in the torque converter (when the damper clutch is released) and the lubricating oil pressure to constant pressures.

**[Operation]**

- (1) The excess fluid which results after the regulator valve has adjusted the line pressure is sent by the torque converter pressure control valve to the torque converter. At this time, the hydraulic pressure which is divided at the No.3 line passes through an orifice, and is then sent from the No.3 port to the chamber in the right side of the valve.

The force generated by the hydraulic pressure of the fluid in this chamber works against the force of the spring to push the valve in order to adjust the pressure inside the torque converter.

When the hydraulic force inside the chamber is weaker than the force of the spring, the latter pushes the valve to the right, and the hydraulic pressure from the regulator valve is supplied to the torque converter.

- (2) When the hydraulic pressure from the regulator valve increases, the hydraulic pressure acting inside the chamber also increases. When the force generated by this pressure becomes greater than the force of the spring, the valve is pushed to the left. When this happens, the No.2 port is opened, the pressure returns to the oil pump and the hydraulic pressure drops.

When the hydraulic pressure drops, the hydraulic pressure acting inside the chamber also drops, so the valve is pushed back to the right by the force of the spring and the No.2 port is closed.

In this way, the torque converter pressure is adjusted so that it does not become greater than a certain constant value.

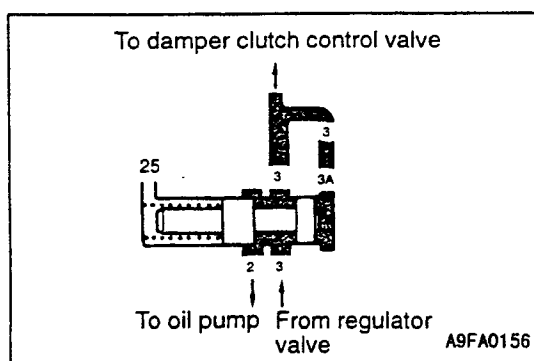
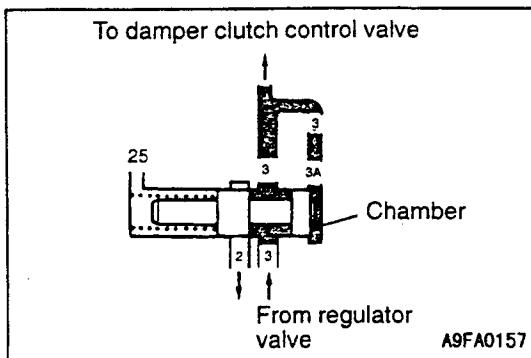

### Damper clutch control valve and damper clutch solenoid valve

- The damper clutch control valve controls the hydraulic pressure which acts on the damper clutch.
- The damper clutch solenoid valve carries out duty control based on signals from the A/T-ECU, and converts these electronic signals to the corresponding hydraulic pressure.

#### [Operation]

- (1) Because the line pressure is applied to the No.24A and No.4A ports when the damper clutch is released (when the damper clutch solenoid valve is off), the sum of the force from the hydraulic pressure acting on the No.7 land and the force of the spring is greater than the force of the hydraulic pressure which is applied as a result of the difference in area between the No.2 land and the No.3 land, and the valve is pushed to the right. When this happens, the hydraulic pressure from the torque converter pressure control valve is sent from the No.3 line to the No.20 line, and hydraulic pressure is thus supplied to the space between the front cover of the torque converter and the damper clutch. Because of this, the torque converter operates as normal without the damper clutch operating.

- (2) When the range where the damper clutch operates is entered, the damper clutch solenoid valve carries out duty control according to the commands from the A/T-ECU and the hydraulic pressure supplied to the No.24A port is reduced.

Because of this, the sum of the force from the hydraulic pressure acting on the No.7 land and the force of the spring is smaller than the force of the hydraulic pressure which is applied as a result of the difference in area between the No.2 land the No.3 land, and the valve is pushed to the left.

When this happens, the hydraulic pressure from the torque converter pressure control valve is released from the No.22 line via the No.3 line to the oil cooler. At the same time, the line pressure in the No.1 line is sent from the No.21 line via the No.23 line to the torque converter. This causes hydraulic pressure to be applied between the damper clutch and the turbine, pushing the damper clutch against the front cover and operating the damper clutch.

### Manual valve

- The manual valve operates in conjunction with the selector lever next to the driver's seat. It switches the fluid line in accordance with the lever position to apply line pressure to each valve.
- The selector lever has the following four positions: P, R, N and D. However, because the valve positions for P and N ranges are the same due to the way the manual control lever operates, the manual valve has only three positions, for (i) R range, (ii) N and P ranges, and (iii) D range respectively.

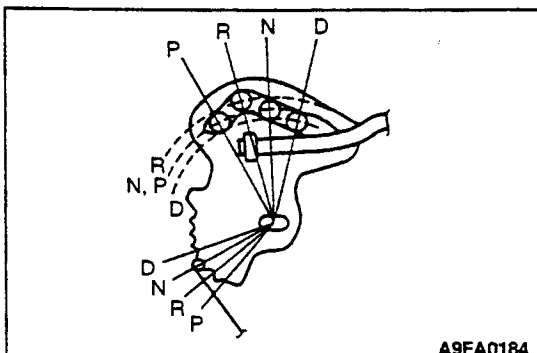
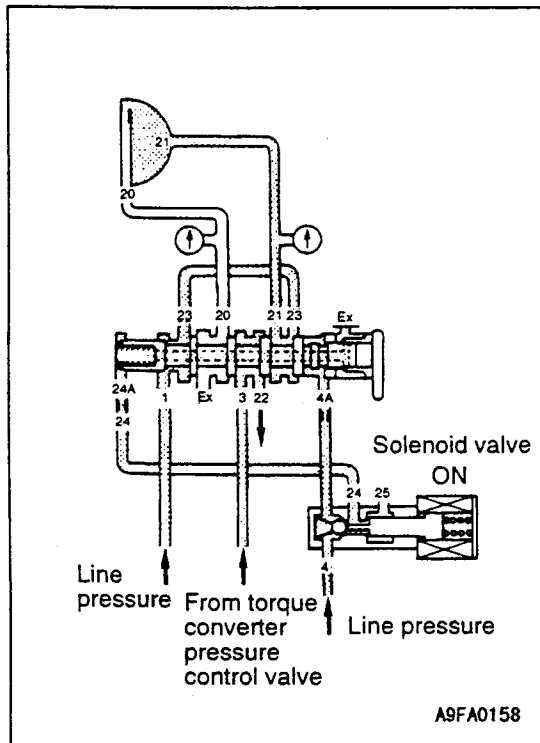
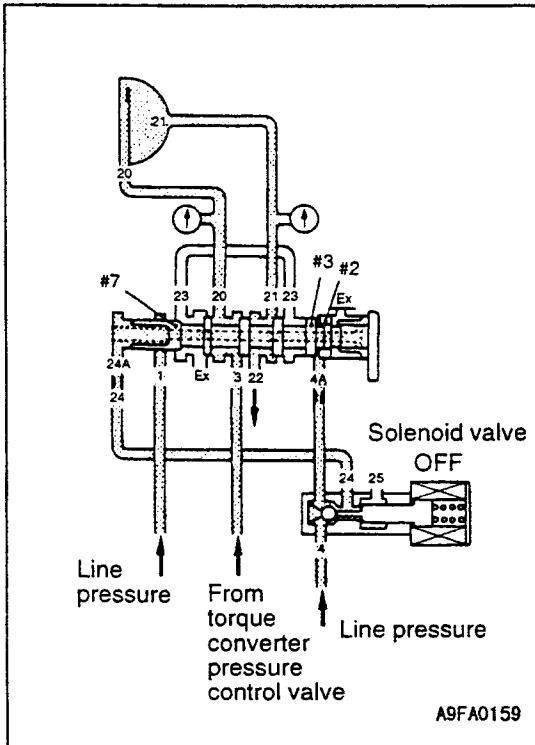

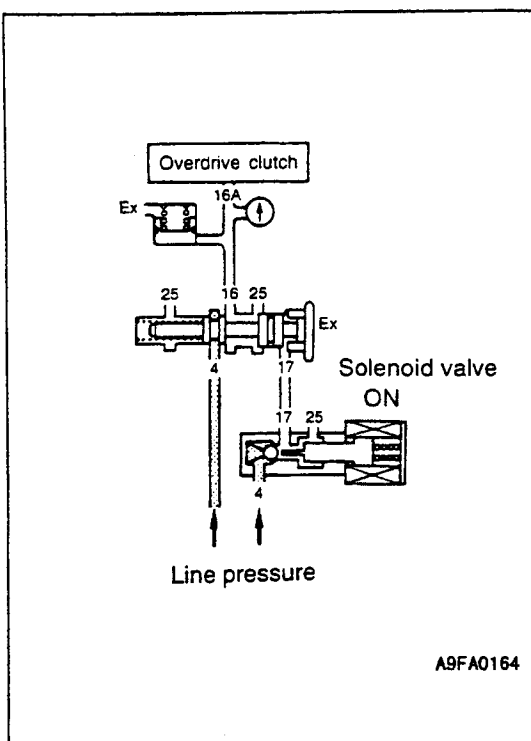
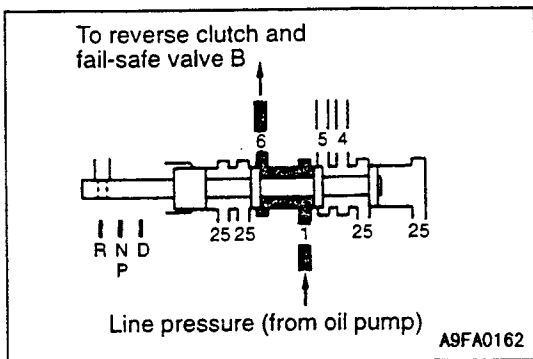
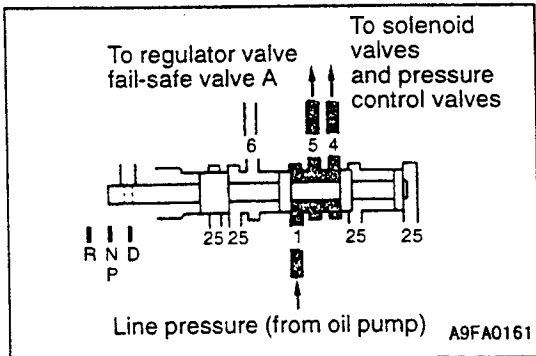
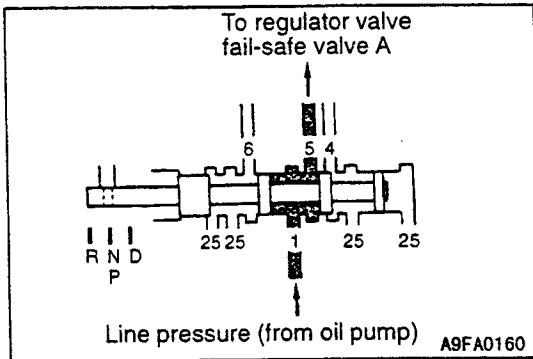

**[Operation]**

- (1) When the manual valve is in the N and P range position, the No.5 port is opened and the line pressure is applied to the regulator valve and to fail-safe valve A.
- (2) When the manual valve is in the D range position, the No.4 and No.5 ports are opened, and in addition to the valves mentioned in (1), line pressure is also applied to the solenoid valves and pressure control valves for the 2nd brake, underdrive clutch, overdrive clutch, damper clutch and fail-safe valve C.
- (3) When the manual valve is in the R range position, the No.6 port is opened and the line pressure is applied to the reverse clutch and to fail-safe valve B.

**Pressure control valve and solenoid valve**

- Except for the reverse clutch and direct clutch, each clutch and brake is equipped with both a pressure control valve and a solenoid valve.
- Each pressure control valve adjusts the hydraulic pressure applied to its respective component in accordance with the control provided by the solenoid valve in order to prevent shocks from occurring during shifting.
- The solenoid valves carry out duty control based on signals from the A/T-ECU, and convert these electronic signals to the corresponding hydraulic pressures.

**[Operation]**

Pressure control valves differ according to the value, but their principle operation is the same.

The following describes this operation, using the overdrive clutch as an example.

- (1) To release overdrive clutch, the hydraulic line is closed by the solenoid valve (the solenoid valve is on), and hydraulic pressure is not supplied to the No.17 line. Because the force of the spring pushes the pressure control valve to the right at this time, the No.16 port is exhausted and hydraulic pressure is not supplied to the overdrive clutch.

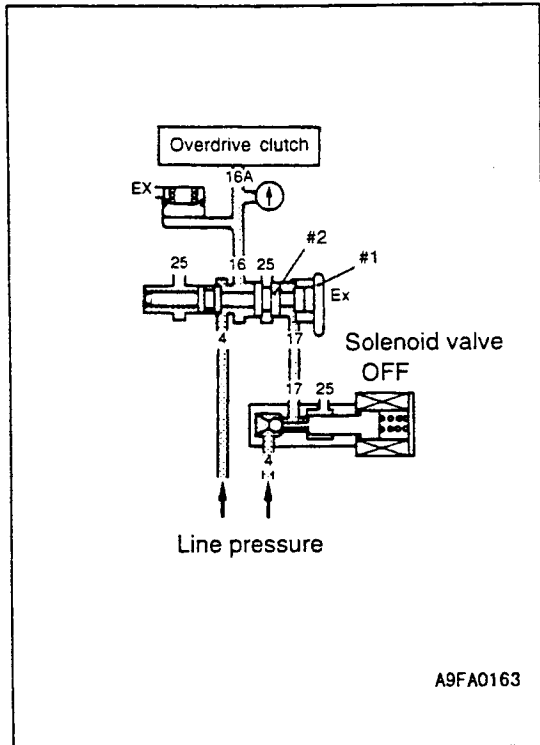

(2) To apply the overdrive clutch, the solenoid valve is carried out by duty control according to the commands from the A/T-ECU, and the check ball is pushed in. This opens the route to the No.17 line, and hydraulic pressure is supplied to the pressure control valve. When hydraulic pressure is supplied to the pressure control valve, a force which pushes the valve to the left is generated from the difference in force between the No.1 land and the No.2 land. This force is greater than the force of the spring, and so the valve is pushed to the left. When this happens, because the No.16 port is opened, the line pressure in the No.4 line is supplied via the No.16 line to the overdrive clutch. When shifting is completed, the solenoid valve turns off, and this causes the hydraulic pressure supplied to the overdrive clutch to equalize until it is the same as the line pressure.

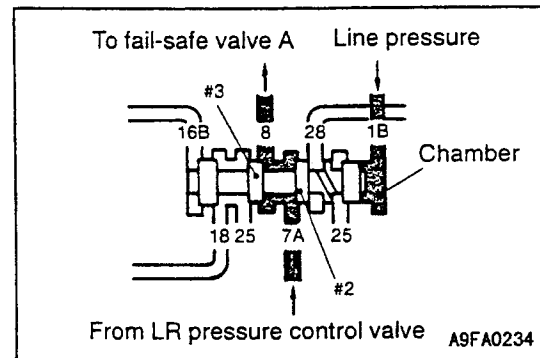

**Switch valve**

- When the overdrive clutch operates, the hydraulic pressure which has been supplied via the switch valve is applied to the regulator valve. This causes the pressure to be reduced when in 3rd, 4th or 5th gear.
- When the fail-safe is operating (when the control relay is off), the hydraulic pressure supplied from the LR pressure control valve to the LR brake is cut off.

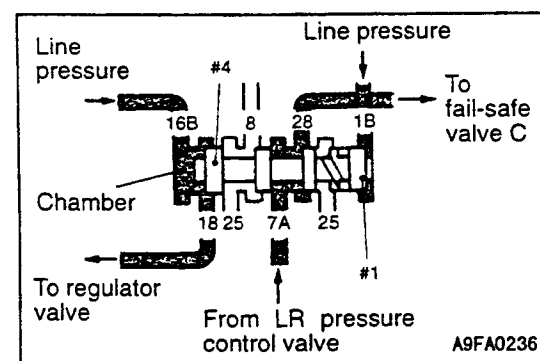

**[Operation]**

(1) At times other than when in 3rd, 4th or 5th gear, because line pressure is supplied to the chamber in the right side of the valve from the No.1B port, the valve is pushed to the left. In addition, because the area of the No.2 land and the No.3 land are the same, the valve will not operate even when hydraulic pressure is being supplied to the No.7A port from the LR pressure control valve.

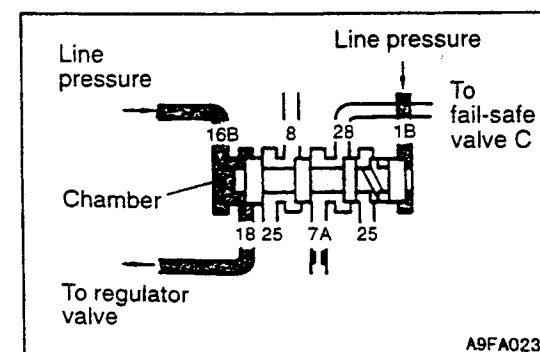

(2) In 3rd, 4th and 5th gear, because hydraulic pressure is also supplied to the chamber in the left side of the valve from the No.16B port, the valve is pushed to the right because of the difference in area between the No.1 land and the No.4 land. This causes the No.18 port to open, and hydraulic pressure is thus supplied to the No.18B port of the regulator valve. With the switch valve, the No.28 port also opens, so when the hydraulic pressure is supplied to the No.7A port, the hydraulic pressure is supplied to the direct clutch via the No.29 port of the fail-safe valve C.



- (3) During fail-safe operation (when the control relay is off) Because all of the solenoid valves turn off when the fail-safe has operated, hydraulic pressure is supplied via the No.7 line to the No.7A port. If the transmission is in 3rd gear, the switch valve is pushed to the right, regardless of the condition of the LR solenoid valve. Moreover, because the areas of the No.2 land and No.3 land are equal, even if the hydraulic pressure is supplied to the No.7A port, the hydraulic pressure from the LR pressure control valve is supplied to the fail-safe valve C via the No.28 port. During fail-safe operation, the fail-safe valve C is pushed to the right so the hydraulic pressure from the No.28 port is cut off.

**Fail-safe valve A**

- When the fail-safe function operates, the LR brake hydraulic pressure is released.
- When released, the hydraulic line to the LR brake is changed to provide quicker and smoother gear shifting.

**[Operation]**

**(1) Neutral range and 1st gear**

The line pressure which passes via the manual valve is sent from the No.5B port to the chamber in the right side of the valve, and the hydraulic pressure from the LR pressure control valve is sent via the switch valve to the No.8A port.

Because of this, the force from the hydraulic pressure acting on the No.1 land is greater than the sum of the force applied as a result of the difference in area between the No.2 land and the No.3 land and the force of the spring, and so valve A1 and valve A2 are pushed to the left. When this happens, because the No.9 port is opened, hydraulic pressure is supplied to the LR brake from the LR pressure control valve.

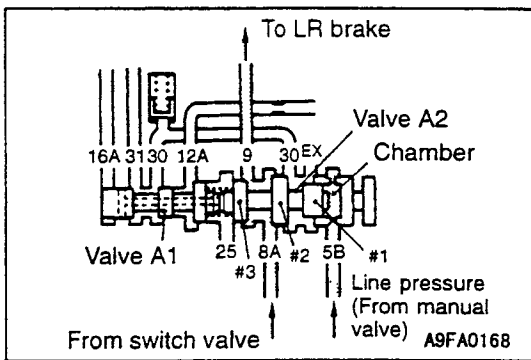

**(2) 2nd gear**

In addition to the No.5B port, hydraulic pressure branches from the No.12 line which supplies hydraulic pressure to the 2nd brake and is supplied to the No.12A port. Because of this, the force from the hydraulic pressure acting on the No.1 land is greater than the sum of the force applied as a result of the difference in area between the No.4 land and the No.5 land and the force of the spring, and so valve A1 and valve A2 are pushed to the left.

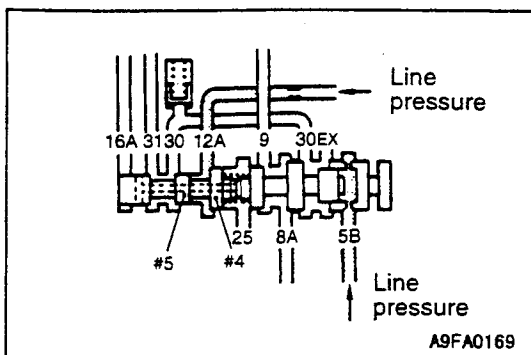

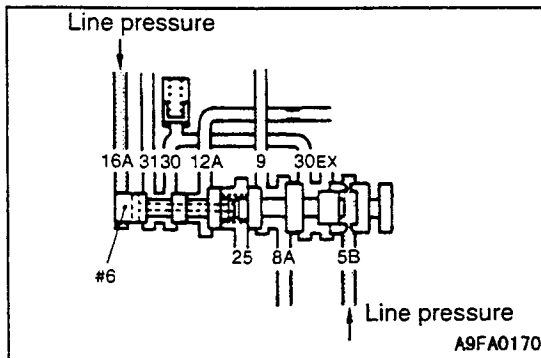
**(3) 3rd and 4th gear**

In addition to the No.5B port, hydraulic pressure branches from the No.16 line which supplies hydraulic pressure to the overdrive clutch and is supplied to the No.16A port.

Because of this, the force from the hydraulic pressure acting on the No.1 land is greater than the sum of the force acting on the No.6 land and the force of the spring, and so valve A1 and valve A2 are pushed to the left.

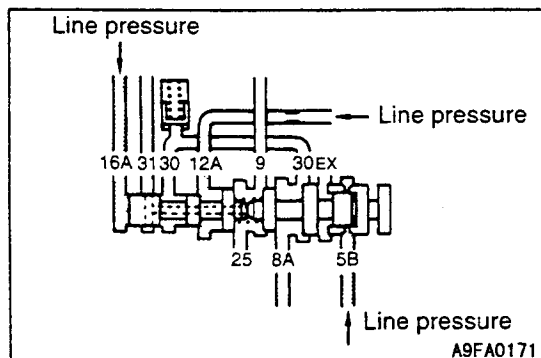
**(4) 4th and 5th gear**

In addition to the No.5B port, hydraulic pressure is supplied to the No.12A port and to the No.16A port.

Because of this, the sum of the force from the hydraulic pressure acting on the No.6 land and the force acting as a result of the difference in area between the No.4 land and the No.5 land is greater than the sum of the force acting on the No.1 land and the force of the spring, and valve A1 and valve A2 are pushed to the right.

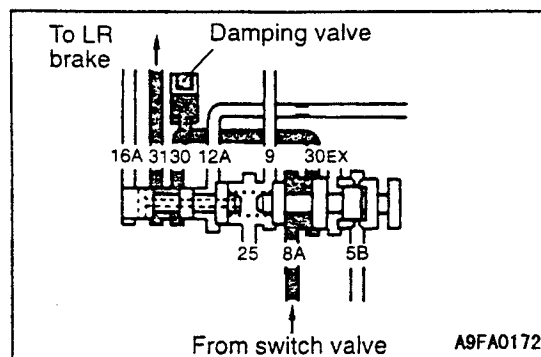
**(5) R range**

Because the No.5 line is open when in R range, hydraulic pressure is not supplied to the No.5B port. Thus, hydraulic pressure is only supplied to the No.8A port.

Because of this, valve A2 is pushed to the right by the hydraulic pressure acting as a result of the spring force and the difference in area between the No.2 land and the No.3 land. On the other hand, valve A1 is pushed to the left by the force of the spring.

When this happens, the LR brake pressure is released quickly from the No.25 port via the No.9 port, and hydraulic pressure is supplied to the LR brake through the No.30 port and the No.31 port.

In this way, the pressure line to the LR brake is changed over so that after the hydraulic pressure to the LR brake drops to zero, it rises again so that shifting from N to R range and from P to R range can be carried out quickly and smoothly.

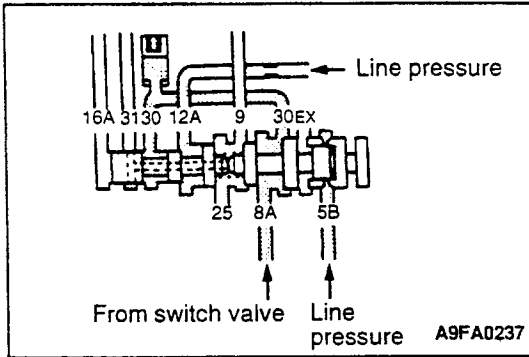

**(6) Fail-safe operation (when the low and reverse brake solenoid valve is malfunctioning)**

**(6-1) 2nd gear**

If the low and reverse brake solenoid valve malfunctions and the hydraulic pressure is supplied from the No.7 port, the No.2 land and No.3 land area is equal and the switch valve will not move. Because of this, the hydraulic pressure will be supplied to the fail-safe valve A from the No.8A port. Valve A1 and valve A2 are pushed to the right by the force achieved by the hydraulic pressure acting as a result of the difference in area between the No.2 land and No.3 land of the fail-safe valve A, and the force achieved by the hydraulic pressure acting as a result of the difference in area between the No.4 land and No.5 land of the valve A1. This will cause the No.9 port to close, so the hydraulic pressure supplied to the low and reverse brake will be cut off.

**(6-2) 3rd gear**

Hydraulic pressure is used from the No.7 port to the switch valve, but as the area of the No.2 land and No.3 land is equal, the switch valve will not move. However, the hydraulic pressure will be supplied to the fail-safe valve C from the No.28 port. The valve is pushed to the right by the hydraulic pressure force acting as a result of the difference in area between the No.2 land and No.3 land of fail-safe C. The No.29 port closes so the hydraulic pressure supplied to the direct clutch is cut off.

**Fail-safe valve B**

- When the fail-safe is operating (when the control relay is off), the supply of hydraulic pressure from the 2nd pressure control valve to the 2nd brake is cut off.

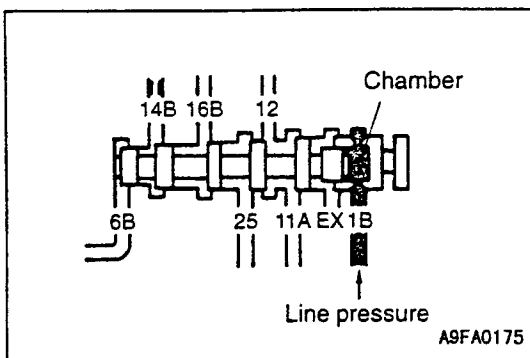

**[Operation]**

**(1) Neutral range**

Because line pressure is supplied from the No.1B port to the chamber in the right side of the valve, the valve is pushed to the left.

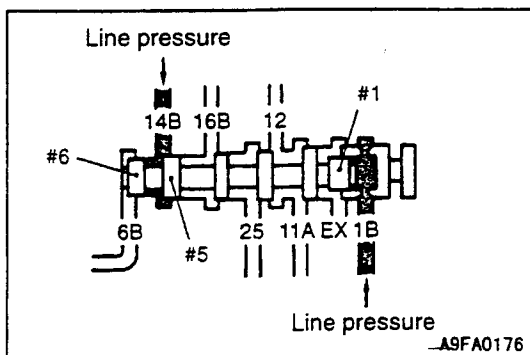

**(2) 1st gear**

In addition to the No.1B port, hydraulic pressure branches from the No.14 line which supplies hydraulic pressure to the underdrive clutch and is supplied to the No.14B port.

Because of this, the force from the hydraulic pressure acting on the No.1 land is greater than the force applied as a result of the difference in area between the No.5 land and the No.6 land and so the valve is pushed to the left.

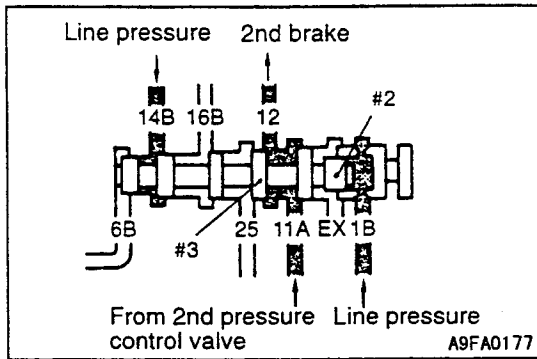
**(3) 2nd gear**

In addition to the No.1B port, hydraulic pressure is supplied to the No.14B port, and also from the 2nd pressure control valve to the No.11A port.

Because of this, the force from the hydraulic pressure acting on the No.1 land is greater than the sum of the force applied as a result of the difference in area between the No.2 land and the No.3 land and the force applied as a result of the difference in area between the No.5 and the No.6 land, and so the valve is pushed to the left.

When this happens, the No.12 port is opened, and so the hydraulic pressure from the 2nd pressure control valve is supplied to the 2nd brake.

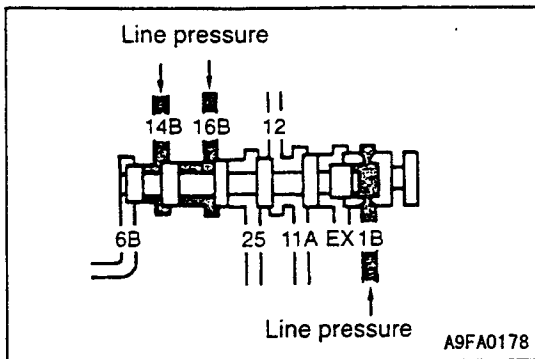
**(4) 3rd and 4th gear**

In addition to the No.1B port, hydraulic pressure is supplied to the No.14B port, and also branches from the No.16A line which supplies hydraulic pressure to the overdrive clutch and is supplied to the No.16B port.

Because of this, the force from the hydraulic pressure acting on the No.1 land is greater than the force applied as a result of the difference in area between the No.4 land and the No.6 land, and so the valve is pushed to the left.

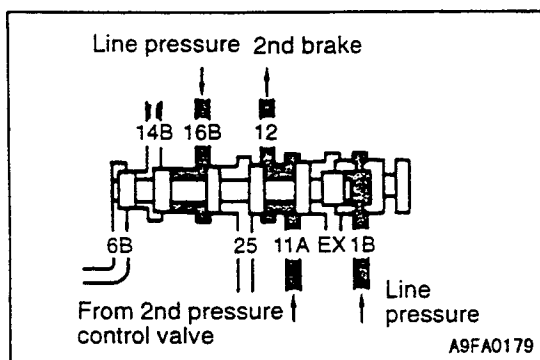
**(5) 4th and 5th gear**

In addition to the No.1B port, hydraulic pressure is supplied to the No.11A port and to the No.16B port.

Because of this, the force from the hydraulic pressure acting on the No.1 land is greater than the sum of the force applied as a result of the difference in area between the No.2 land and the No.3 land and the force applied as a result of the difference in area between the No.4 land and the No.5 land, and so the valve is pushed to the left.

When this happens, the No.12 port is opened, and so the hydraulic pressure from the 2nd pressure control valve is supplied to the 2nd brake.

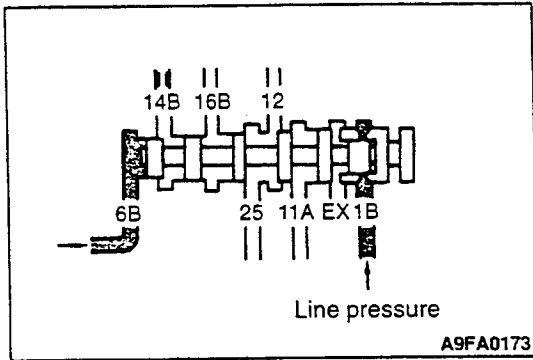

(6) Reverse

In addition to the No.1B port, the line pressure which passes via the manual valve is sent from the No.6B port to the chamber in the right side of the valve. Because of this, the valve is pushed to the right as a result of the difference in area between the No.1 land and the No.6 land.

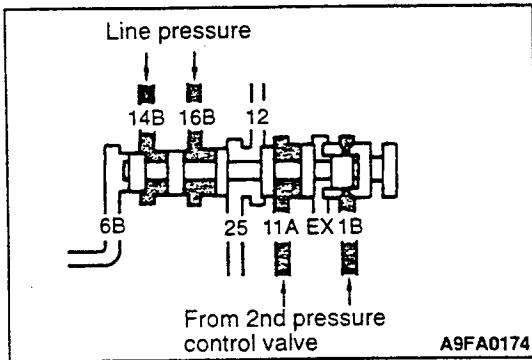

(7) Fail-safe (when the control relay is off)

Because all of the solenoid valves turn off when the fail-safe has operated, hydraulic pressure is supplied to the No.11A port via the No.11 line, and it is also supplied to the No.14B port and to the No.16B port. Because of this, the force from the hydraulic pressure acting on the No.1 land is smaller than the sum of the force applied as a result of the difference in area between the No.2 land and the No.3 land and the force applied as a result of the difference in area between the No.4 land and the No.6 land, and so the valve is pushed to the right. As a result, the No.12 port can connect to the No.25 port and the 2nd brake hydraulic pressure is released. Also, the hydraulic pressure from the 2nd pressure control valve is cut off by fail-safe valve B.

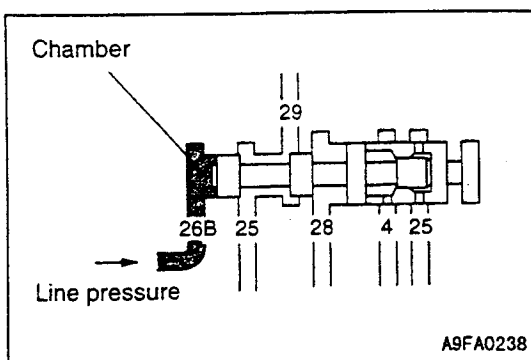

Fail-safe valve C

- When the fail-safe is operating (when the control relay is off), the supply of hydraulic pressure from the switch valve to the direct clutch is cut off.

[Operation]

(1) Neutral and R range

Because line pressure is supplied from the No.26B port to the chamber in the left side of the valve, the valve is pushed to the right.

(2) 1st, 2nd and 3rd gear

In addition to the No.26B port, line pressure is supplied to the No.4B port. Because of this, the force from the hydraulic pressure applied as a result of the difference in area between the No.1 land and the No.2 land is greater than the force acting on the No.1 land, and so the valve is pushed to the left.

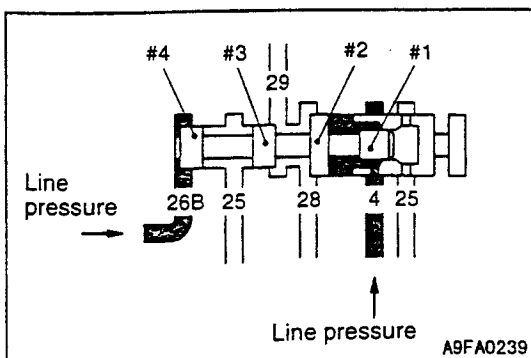

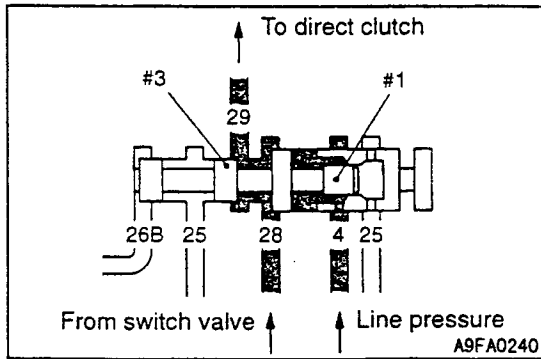

**(3) 4th and 5th gear**

In addition to the No.4 port, the hydraulic pressure is supplied to the No.28 port. However, as the hydraulic pressure is not supplied to the No.26B port, the valve is pushed to the left side by the hydraulic pressure acting as a result of the difference in area between the No.1 and No.3 land. Because of this, the No.29 port opens and the hydraulic pressure from the No.28 valve of the switch valve is supplied to the direct clutch.

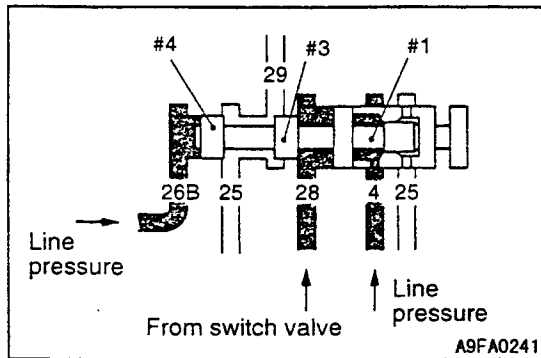

**(4) Fail-safe (when the control relay is off)**

The hydraulic pressure from the No.4 port, No.28 port and No.26B port is supplied, and the Area of the No.3 land and No.4 land is equal, so the valve is pushed to the right by the hydraulic force acting on the No.1 land. Because of this, the No.29 port is discharged by the No.25 port, and the hydraulic pressure supply from the No.28 port of the switch valve to the direct clutch is cut off.

**Accumulator**

- The accumulators used are all different from each other line with the differing hydraulic pressure characteristics of each clutch and brake.

**ATF**

- A long life automatic transmission fluid (ATF-SPII or ATF-SPIIM) has been introduced which eliminates the need to periodically replace the transmission fluid.

**OIL FILTER**

- In addition to the main oil filter inside the A/T, a sub oil filter which threads onto the outside of the A/T case has also been provided. The sub oil filter can filter traps extra-fine impurities that are not removed by the main oil filter.
- The sub oil filter has the same appearance as the engine oil filter, but it has a different filtering capacity. Because of this, identification marks are painted on the top of the oil filters as they are not interchangeable.

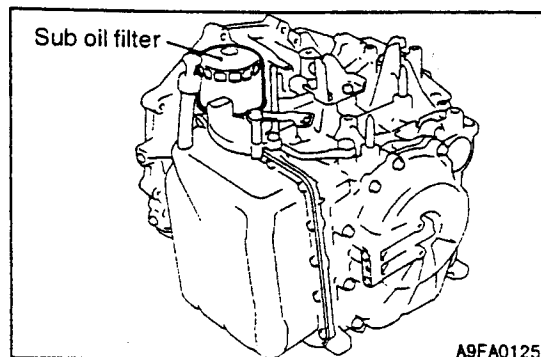
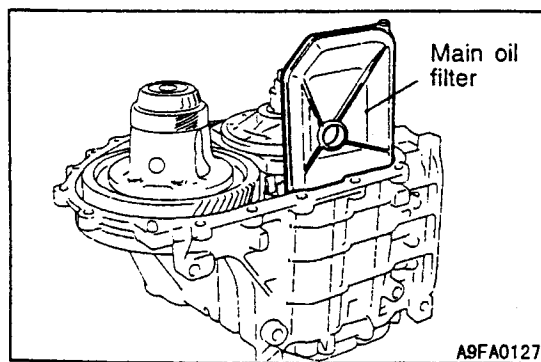

Item	Main oil filter	Sub oil filter
Filtration method	Non-woven cloth	Total filtering, paper filter type

## SENSORS AND ACTUATORS

## Reference table

Part Name	Function	Applicable model	
		Without TCL	With TCL
Input shaft speed sensor	Detects input shaft speed (turbine speed) at the retainer of UD clutch.	○	○
Output shaft speed sensor	Detects output shaft speed (transfer drive gear speed) at the direct planetary carrier.	○	○
Crank angle sensor	Detects engine speed at the crankshaft.	○	○
TPS	Detects the depression degree of the accelerator pedal by means of a potentiometer.	○	-
APS	Detects the depression degree of the accelerator pedal by means of a potentiometer.	-	○
Oil temperature sensor	Detects ATF temperature by means of a thermistor.	○	○
Inhibitor switch	Detects the selector lever position by means of a contact switch.	○	○
Stop lamp switch	Detects if the brake is applied by means of a contact switch at the brake pedal.	○	○
Vehicle-speed sensor	Detects vehicle speed at the speedometer gear.	○	○
Air conditioner load switch	Detects if the air compressor operates or not by means of a dual pressure switch.	○	○
Idle position switch	Detects that the accelerator pedal is fully depressed by means of a contact switch with built-in TPS (APS).	○	○
Select switch	Detects sport mode selection by means of contact switch of selector lever.	○	○
Upshift switch	Detects an upshift request in sport mode by means of contact switch of selector lever.	○	○
Downshift switch	Detects a downshift request in sport mode by means of contact switch of selector lever.	○	○
A/T control relay	Turns on and off solenoid valve power supply circuit.	○	○
DCC solenoid valve	Adjusts hydraulic pressure to the damper clutch control valve to control the damper clutch.	○	○
LR (DIR) solenoid valve	Adjusts hydraulic pressure to the pressure control valve to control shifting.	○	○
2ND solenoid valve	Adjusts hydraulic pressure to the pressure control valve to control shifting.	○	○
UD solenoid valve	Adjusts hydraulic pressure to the pressure control valve to control shifting.	○	○
OD solenoid valve	Adjusts hydraulic pressure to the pressure control valve to control shifting.	○	○
RED solenoid valve	Adjusts hydraulic pressure to the pressure control valve to control shifting.	○	○
N range lamp	Warns oil temperature, activates fail-safe function, and indicates diagnosis codes.	○	○
Torque reduction request signal	Transmits torque reduction request to engine-ECU with ON/OFF signal	-	○
TCL-ECU	Receives information required from control through communication with A/T-ECU	-	○
Engine-ECU	Receives information required from control through communication with A/T-ECU	○	-

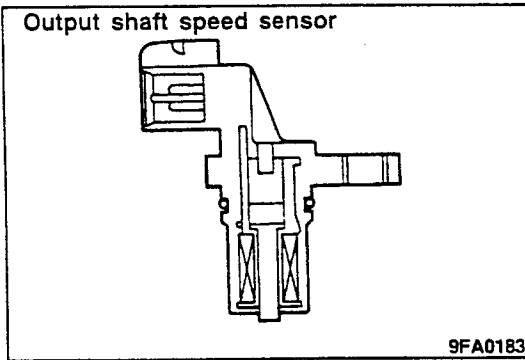

**Input shaft speed sensor and output shaft speed sensor**

- The sensor bodies and connectors have been integrated. With this, the input shaft and output shaft sensors have been separated.
- A 2-system terminal has used to improve reliability.
- The sensor section is the same as before.
- The shapes of the input shaft speed sensor and the output shaft speed sensor differ, but the basic configuration is the same.

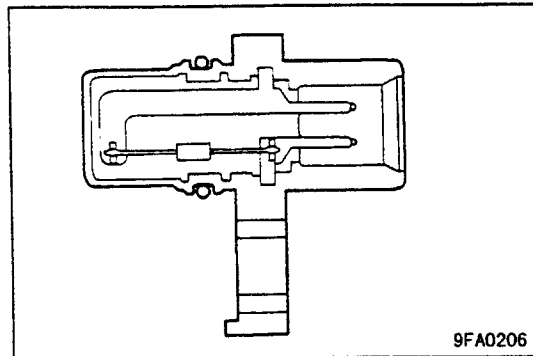

**Oil temperature sensor**

- The sensor bodies and connectors have been integrated.
- The characteristics of the thermistor are the same as before.

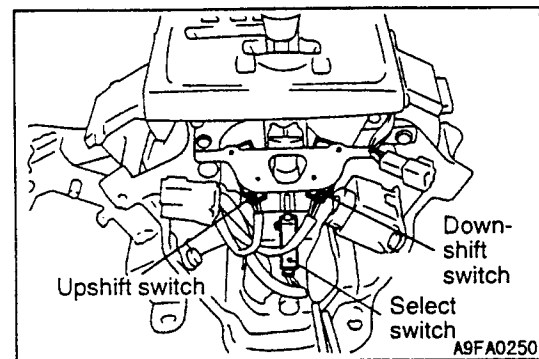

**Inhibitor switch**

- The selector lever is a 4-position type (P, R, N, D), but a 7-position type inhibitor switch is used.

**Select switch, upshift switch and downshift switch**

- The select switch, upshift and downshift switches are installed at the lower section of the selector lever.
- When the selector lever is operated to the sports mode side, the select switch turns ON.
- Each time the selector lever is operated to the up (down) side, the up (down) shift request signal is output to the A/T-ECU by the up (down) shift switch.

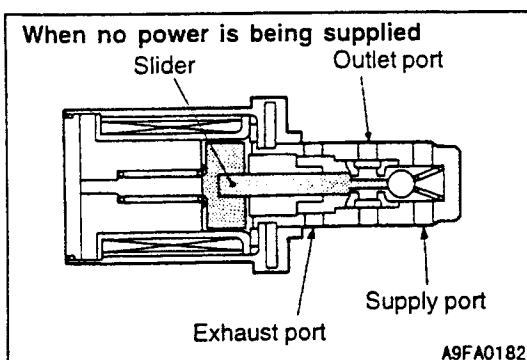

**Solenoid valve**

- The same type of solenoid valve is used as the DCC, LR (DIR), 2ND, UD, RED and OD solenoid valves.
- The solenoid valves are of a normally-open type, so that the route from the supply port to the outlet port is open when no power is being supplied.

**SERIAL COMMUNICATION BETWEEN ECU**

Data necessary for each control are sent and received between the ECUs.

(1) Vehicles with TCL

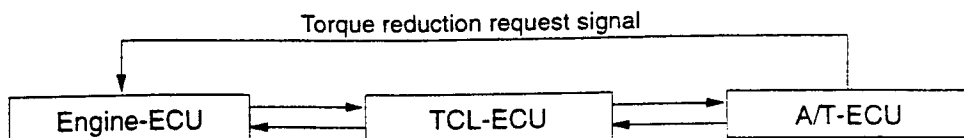

(2) Vehicles without TCL

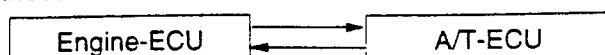



## CONTROL UNIT

The A/T-ECU uses a hybrid-type 64-pin connector. The terminals of this connector are arranged as shown below.

## A/T-ECU connector

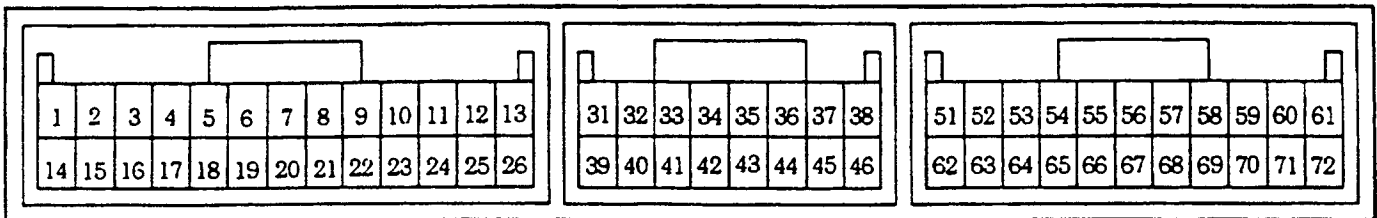

9FA0133

- |  |  |
|--|--|
| 1. UD solenoid valve   | 40. –  |
| 2. Solenoid valve power supply   | 41. –  |
| 3. Solenoid valve power supply   | 42. –  |
| 4. 1st-gear shift indicator lamp   | 43. Sensor earth   |
| 5. 3rd-gear shift indicator lamp   | 44. Oil temperature sensor                                       |
| 6. 5th-gear shift indicator lamp   | 45. Throttle opening angle sensor (TPS, APS)                     |
| 7. –   | 46. –  |
| 8. –   | 51. RED solenoid valve   |
| 9. –   | 52. –  |
| 10. A/C compressor load signal   | 53. Communication output to engine-ECU<br><vehicles without TCL> |
| 11. Power supply   | Communication output to TCL-ECU<br><vehicles with TCL>           |
| 12. Earth  | 54. Communication input to engine-ECU<br><vehicles without TCL>  |
| 13. Earth  | Communication input to TCL-ECU<br><vehicles with TCL>            |
| 14. OD solenoid valve  | 55. Inhibitor switch P   |
| 15. DCC solenoid valve   | 56. Inhibitor switch N   |
| 16. 2nd solenoid valve   | 57. Select switch  |
| 17. 2nd-gear shift indicator lamp  | 58. Downshift switch   |
| 18. 4th-gear shift indicator lamp  | 59. Stop lamp switch   |
| 19. –  | 60. –  |
| 20. –  | 61. –  |
| 21. Torque reduction request signal to engine-ECU<br><vehicles with TCL> | 62. LR solenoid valve  |
| 22. –  | 63. Diagnosis output   |
| 23. Diagnosis control  | 64. –  |
| 24. Power supply   | 65. –  |
| 25. Earth  | 66. Inhibitor switch R   |
| 26. Earth  | 67. Inhibitor switch D   |
| 31. Input shaft speed sensor   | 68. Upshift switch   |
| 32. Output shaft speed sensor  | 69. Vehicle-speed sensor   |
| 33. Crank angle sensor   | 70. –  |
| 34. –  | 71. A/T control relay  |
| 35. –  | 72. Earth  |
| 36. Idle position switch   |  |
| 37. –  |  |
| 38. Back-up power supply   |  |
| 39. –  |  |

OUTLINE OF CONTROL

Shift control

- For the newly-developed automatic transmission, we have developed the next generation of shifting called the "clutch-to-clutch" method which directly switches between the clutches during shifting. In this new method, the hydraulic control when the shifting lever is operated and during speed shifting is carried out independently with the solenoid valves provided for each clutch and brake. This allows the clutch changeover to be controlled in detail, and an excellent shift feeling and response to be provided.

(1) SOLENOID VALVE OPERATION

Each solenoid valve is controlled during shifting by commands from the A/T-ECU

Gear range	Solenoid valve					
	LR (DIR)	2ND	UD	OD	RED	DCC (Reference)
1st	OFF [LR]	ON	OFF	ON	OFF	OFF
2nd	ON [LR]	OFF	OFF	ON	OFF	OFF
3rd	ON [DIR]	ON	OFF	OFF	OFF	OFF
4th	OFF [DIR]	ON	OFF	OFF	ON	ON
5th	OFF [DIR]	OFF	ON	OFF	ON	ON
Reverse	OFF [LR]	ON	ON	ON	OFF	OFF
N, P	OFF [LR]	ON	ON	ON	OFF	OFF

(2) SHIFT PATTERN CONTROL

Optimum shift pattern control is provided by the INVECS-II based on the road and driving conditions.

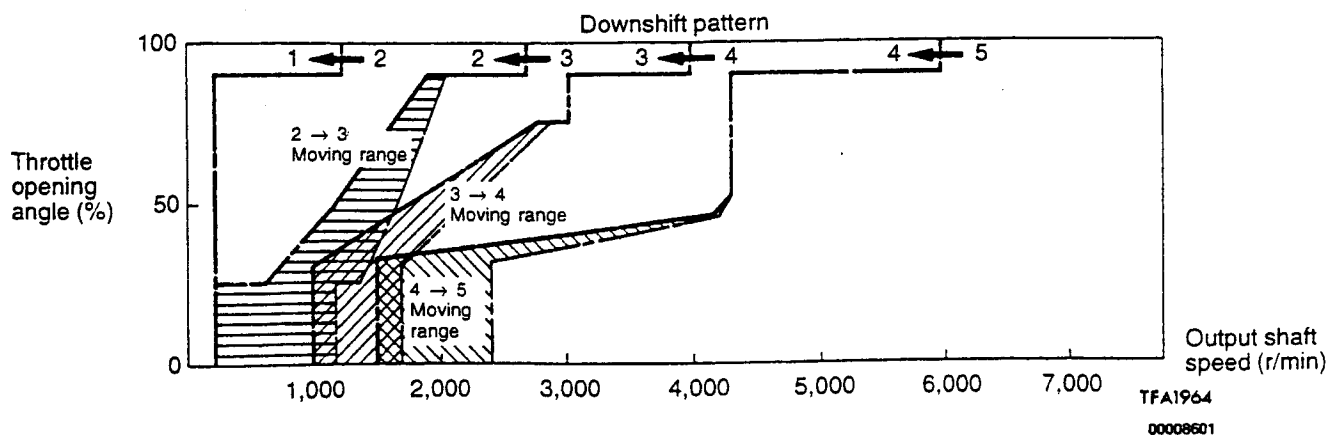
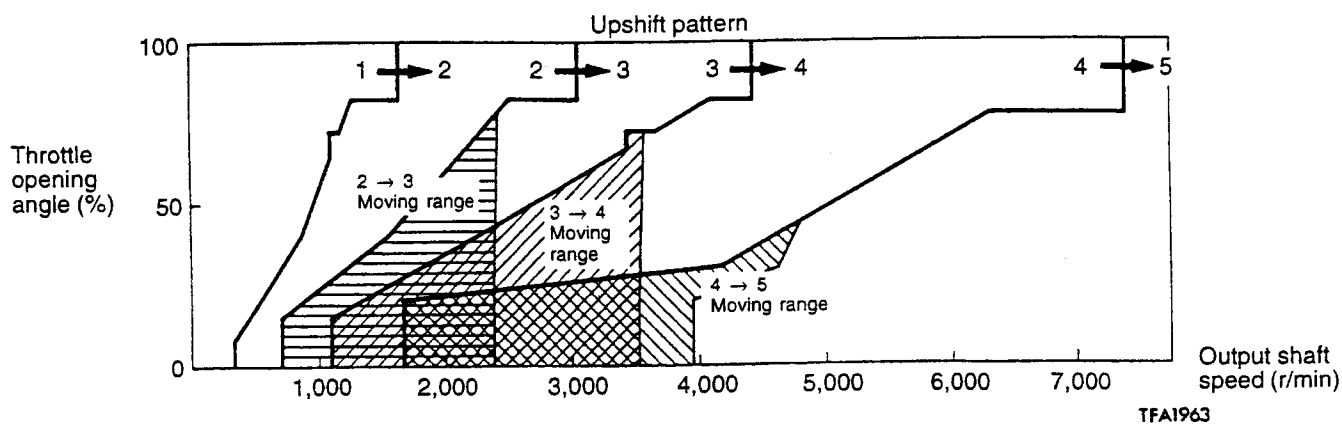

## INVECS-II

The INVECS-II consists of "optimization control over the total driving range" which gives the optimum shifts required by the average driver, regardless of the road conditions. "Learning control" continually adjusts the shift timing in response to corrections required by the driver.

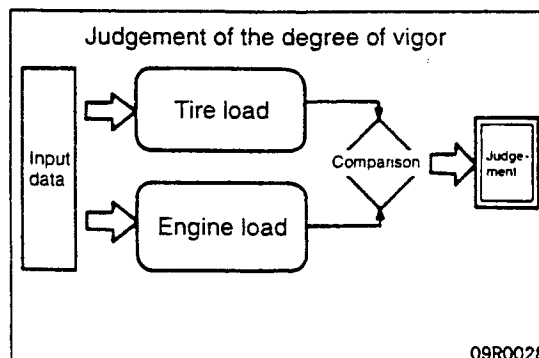
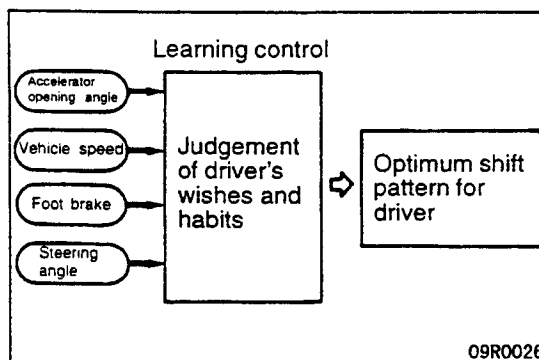
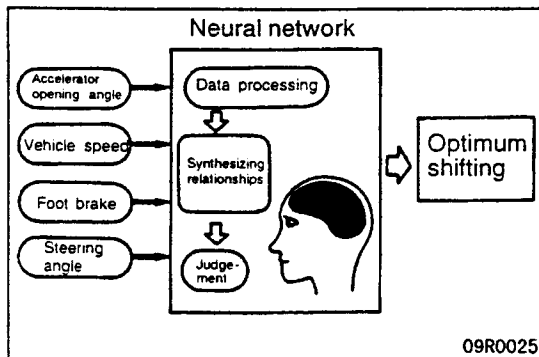
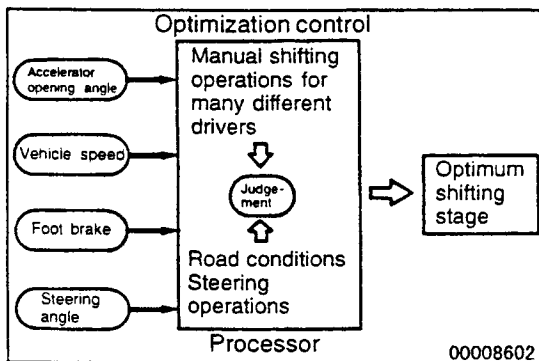

## (1) Optimization control over the total driving range

- The INVECS-II processor has been pre-programmed with the optimum manual shifting operations for many different drivers driving under a variety of road conditions. The processor receives signals corresponding to the accelerator opening angle, vehicle speed, foot brake, steering angle, and uses these signals to judge what kind of conditions the vehicle is currently being driven at. It then outputs the optimum shifting operation that corresponds to this judgement.

In this way, the INVECS-II gives the optimum shifting stages under a variety of road conditions.

- The processor carries out a series of extremely complex calculations in order to output the optimum shifting operation, and as a result it was difficult to achieve a high level of precision using the same fuzzy logic circuit that was used in the previous INVECS. Therefore, a "neural network" circuit which represents the latest in logic circuit technology was adopted for the INVECS-II in order to make this ideal shifting possible for the first time. The "neural network" circuit is a high-performance logic circuit which replicates as closely as possible the judgement processes carried out by the human brain; it processes large quantities of input data in various ways to synthesize relationships between this data, and generates the appropriate response in an instant time, just as the brain does.

## (2) Learning control

- The optimum shifting operations which have already been programmed can be recreated by means of optimization control. However, some drivers require a response which suits their own tastes more; the same vehicle might also be driven by skilful, not-so-skilful or several different drivers; and the driver may even change their own feeling about the optimum response to be had. In response to factors such as these, the INVECS-II also carries out learning control in which it judges the driving operations being carried out by the driver from information such as the accelerator opening angle, vehicle speed, foot brake and steering angle, and changes the shift timing to match the current driver's wishes and habits.
- The processor judges and learns the degree of vigor in each driver's way of driving. The larger values for the engine load and the tire load become the degree of vigor for that moment, and the vigorousness of the driver's driving style is judged from the size and frequency of these values.

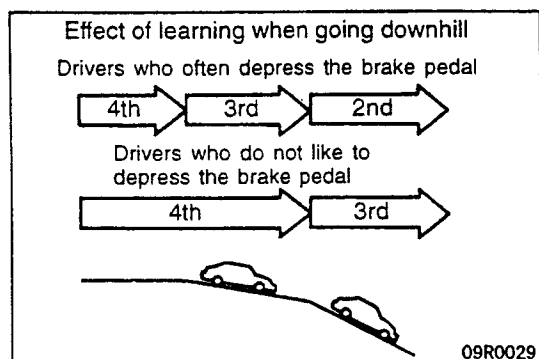
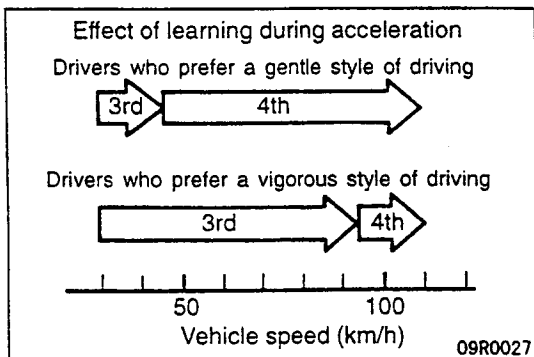

- For example, for drivers who prefer a more leisurely style of driving, the processor analyses this driving pattern and provides a more gentler degree control by upshifting at lower engine speeds. For drivers who prefer a more vigorous style of driving, the transmission stays in a lower gear until the engine speed becomes relatively high, in order to provide a more sporty driving feeling.
- For drivers who frequently depress the brake pedal when going downhill, the learning control causes the transmission to downshift earlier so that the engine brake can be used more easily. Conversely, for drivers who do not like to depress the brake pedal much even when going downhill, down-shifting is made more difficult in order to suppress the engine brake.

**Sports mode**

Easy driving can be realized with INVECS-II. However, to answer to users who want the experience the world of "Fun to Drive", a dimension differing from easy driving, sporty driving with the feel of manual transmission has been made possible even with the automatic transmission vehicle. This is a sports mode developed as a new function for sport vehicles.

(1) Features of sports mode

- Swift up and down-shifting is possible just by moving the selector level forward and backward.
- The gears can be changed with the accelerator pedal depressed. This prevents the loss of power, and provides hot and high performance driving.

- The gears can be freely and easily selected even on curvy roads or mountain roads. This allows easy down-shifting just before entering or leaving corners, and allows drivers to enjoy dynamic and sporty driving not possible with conventional automatic transmission vehicles.
- The current gear stage is indicated with the shift indicator lamp to assist with lever operations in the sports mode. The gear stage is also displayed even when travelling in the D range, to assist in selecting the sports mode.

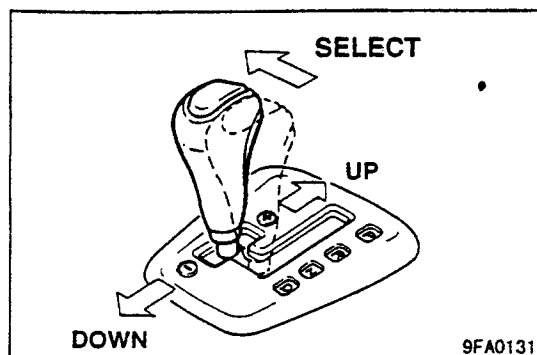

(2) Operation in the sports mode

- When the selector lever is set to the sports mode side, the select switch turns on enabling sports mode travel.
- Each time the selector lever is operated to the (+)/(-) side, the gear shifts up or down one gear.
- If the shift lever is quickly operated twice to the (-) side, skip shifting in which one gear is skipped will take place.
- Shifting from 1st to 2nd, or 2nd to 1st is possible even when stopped by using the selector lever.

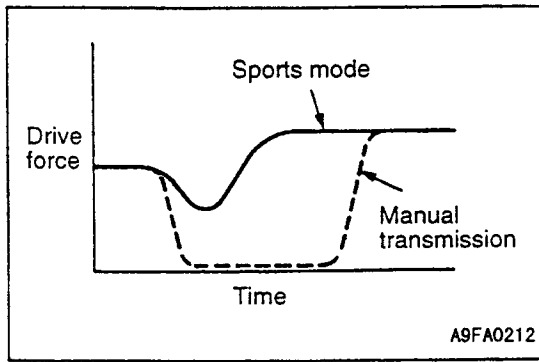

(3) Shift response

- In the sports mode, the clutch pedal does not need to be depressed as often as with a manual transmission vehicle. Thus, gears can be shifted quickly without the drive force diminishing. Quick response shifting that answers the driver's needs is possible.

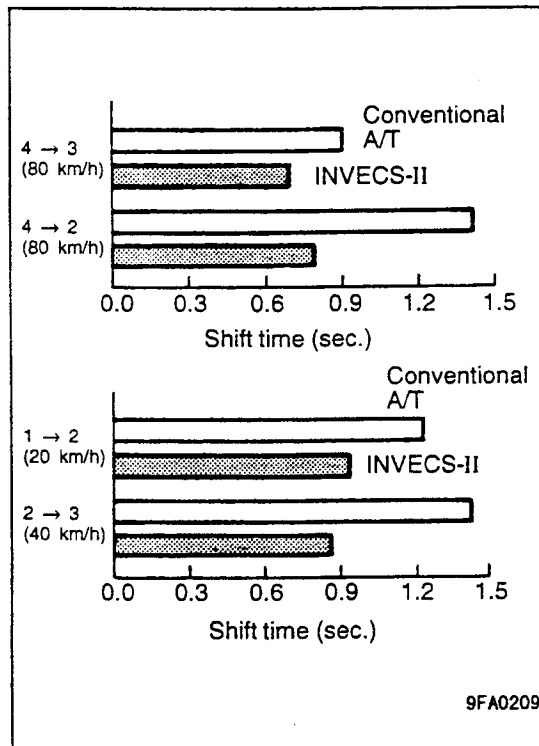

- Compared to the conventional A/T manual shifting, the down-shifting time is shortened by 0.1 sec. or more, and the up-shifting time by 0.2 sec. or more.

Hydraulic control during shifting

(1) CLUTCH-TO-CLUTCH CONTROL

- This newly-developed automatic transmission controls the release-side clutch (or brake) and the engage-side clutch (or brake) simultaneously during shifting. As a result, detailed control

is carried out during clutch changeover based on the torque capacities of both clutches. This prevents engine racing and clutch interlocking during shifting and makes overall shifting smoother and improves response.

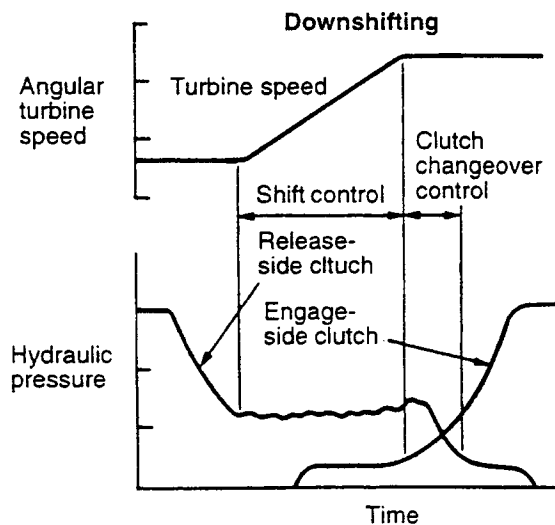
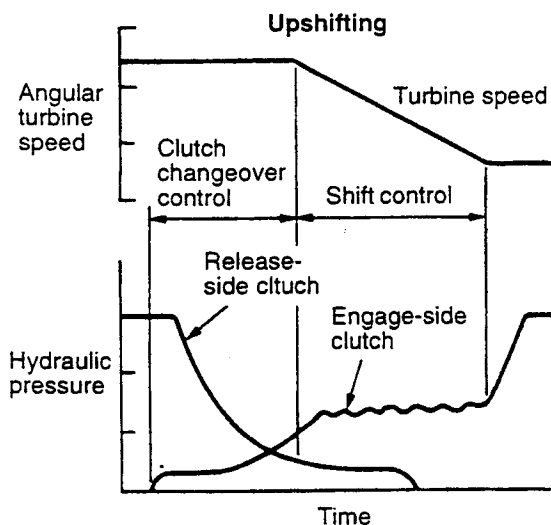

(2) FEEDBACK CONTROL AND LEARNING CONTROL

- Feedback control is carried out so that the change in speed of the input shaft during shifting equals a pre-determined target value for all shifting operations. As a result, changes in torque during shifting can be controlled to ideal levels, thereby greatly improving the shifting feeling.

- In addition, learning control which carries out employed automatic control compensation with respect to changes in the engine characteristics and changes in the transmission over time is also employed in order to stabilize the shifting feeling.

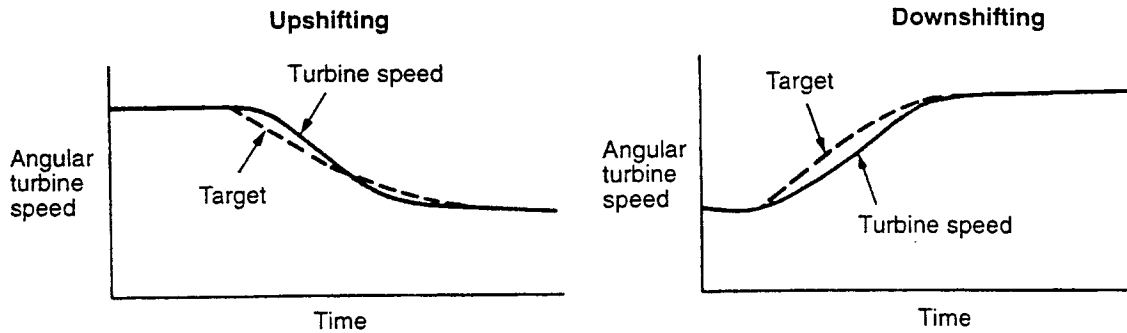

A9FA0208

(3) ENGINE-TRANSMISSION TOTAL CONTROL

- During upshifting, a torque reduction request signal is sent from the AT-ECU to the engine-ECU. The engine-ECU increases the amount of retardation of the ignition timing in response to this signal to reduce the engine torque. This reduces the amount of torque fluctuation during shifting to provide a smoother shifting feeling.

- Data regarding the intake pipe negative pressure for the engine which is calculated by the engine-ECU is transmitted to the AT-ECU with serial communication. The AT-ECU determines the clutch (or brake) hydraulic pressure based on this signal. Compared to previous TPS methods, this method increases the setting precision for the clutch (or brake) hydraulic pressure and thus improves the shifting feeling.

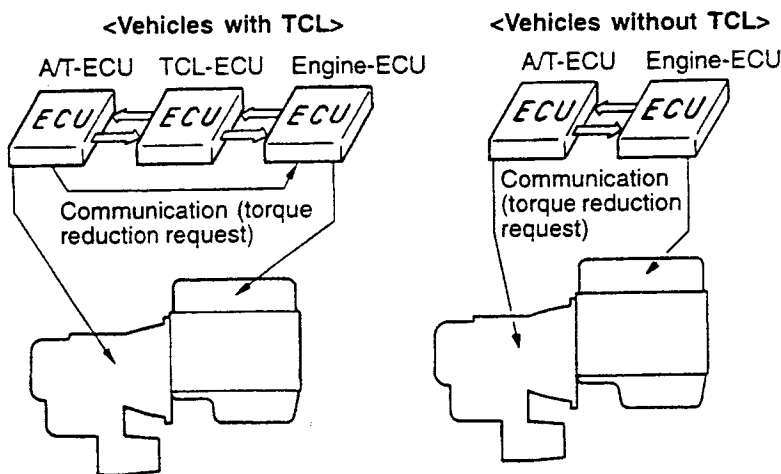

9FA0251

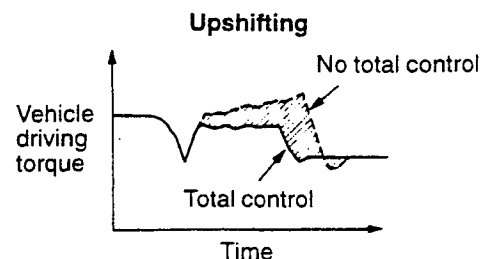

9FA0136  
00008603

### Damper clutch control

- The damper clutch control consists of a partial lock-up and full lock-up controls. The partial lock-up control slides the damper clutch slightly at the low speed ranges. The full lock-up control

is carried out at the high speed range. Both controls contribute to low fuel costs and quietness.

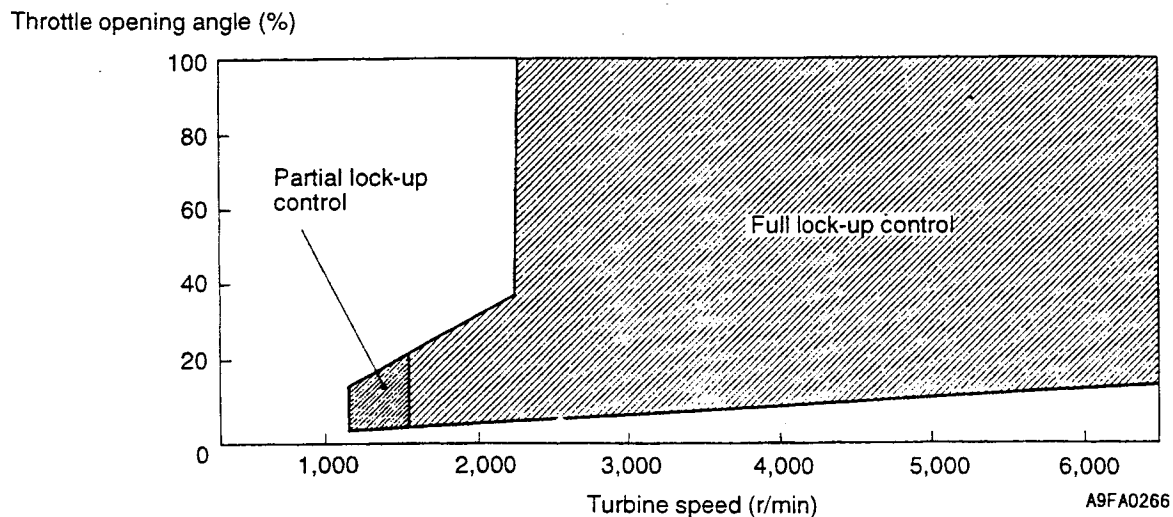

### FAIL-SAFE/FOOLPROOF AND DIAGNOSIS FUNCTIONS

- If a problem should occur inside the A/T-ECU and or with any of sensors or actuators, or if the driver makes a mistake in operation, the fail-safe/foolproof function takes over control to ensure the safety of the passengers and the vehicle.
- The diagnosis function constantly monitors the signals input from each sensor and the signals output by each actuator, and if there is an abnormality in any signal, the nature of the abnormality is recorded.

#### Fail-safe/foolproof function

- If a problem should occur in the electronic control system, driving is still possible in 3rd gear (in D or 3 range) or 2nd gear (in 2 or L range) (except when any one of diagnostic trouble codes 31 – 36, 41 – 46, 46, 54, 55, or 71 is output).
- A fluid temperature warning function is provided. This function causes the N range lamp to flash rapidly (2Hz) if the temperature of the automatic transmission fluid rises too high as a result of excessive driving.
- The transmission will not shift into reverse while moving forward, even if the selector lever is moved to the R range position (when driving at 7 km/h or higher).
- If the engine over-rotates after down-shifting during sports mode travel, the gears will not shift even when down-shifting is attempted.

**Self-diagnosis function**

**(1) Diagnosis codes**

**i) Diagnosis items and fail-safe items**

Fail-safe items are those diagnosis items which are more severe.

- Diagnosis items: Code Nos.11 – 15, 21, 26, 51, 52, 56
- Fail-safe items: Code Nos.22, 23, 31 – 36, 41 – 46, 54, 55, 71

**ii) Display method and display order**

**a) During normal driving**

When the fail-safe function is operating, the N range lamp flashes slowly (1 Hz) to inform the driver (in D range only).

**b) During service (when not using the MUT-II)**

- The diagnosis codes are output when the diagnosis control terminal is earthed for 1 second or more while the selector lever is in P range and the vehicle speed is 0 km/h.
- If no diagnosis codes have been memorized (when the condition is normal), the N range lamp will flash at a constant interval (0.5 second).
- Diagnosis code output is displayed by means of the flashing of the N range lamp, with different illumination times for the tens digit and the units digit.

**c) Display order**

Codes are displayed in the order in which there are generated, with all fail-safe items being displayed before diagnosis items are displayed.

**iii) Memorizing**

- Up to 8 diagnosis items and 3 fail-safe items can be memorized.
- If more diagnosis codes are generated than can be memorized, the older codes will be erased and the newer code will be memorized. This happens for both fail-safe and diagnosis codes.
- If the identical codes are generated, that code is memorized only once.

**iv) Erasing diagnosis codes**

**a) Automatic erasure**

If the ATF temperature rises to 50°C 200 times repeatedly after the last diagnosis code has been recorded, all diagnosis codes which have been memorized will then be erased.

**b) Forced erasure**

The diagnosis codes can be erased using the MUT-II if all the conditions below are satisfied.

- The ignition switch is at ON
- No pulse is detected from the crank angle sensor
- No pulse is detected from the output shaft speed sensor
- No pulse is detected from the vehicle-speed sensor
- The fail-safe function is not operating

**Chart classified by diagnosis codes**

Item		Judgement condition	Backup	Diagnosis code No.
Throttle position sensor <vehicles without TCL> or accelerator pedal position sensor <vehicles with TCL>	Short-circuit	TPS output is 4.8 V or higher during idling.	<ul style="list-style-type: none"> <li>● Throttle opening voltage is assumed to be 2.5 V.</li> <li>● INVECS-II is inhibited.</li> </ul>	11
	Open circuit	TPS or APS output is 0.2 V or lower except during idling.	<ul style="list-style-type: none"> <li>● Throttle opening voltage is assumed to be 2.5 V.</li> <li>● INVECS-II is inhibited.</li> </ul>	12
	Incorrect sensor adjustment	TPS or APS output is 0.2 V or lower or 1.2 V or higher during idling.	INVECS-II is inhibited.	14
Oil temperature sensor	Open circuit	Oil temperature sensor output is 2.6 V or more (oil temperature does not increase) even after driving for 10 minutes or more	<ul style="list-style-type: none"> <li>● Oil temperature is assumed to be 80°C.</li> <li>● INVECS-II is inhibited.</li> </ul>	15
Crank angle sensor	Open circuit	No output pulse from the crank angle sensor is detected for 5 seconds or more when the vehicle speed is 25 km/h or more.	Damper clutch control is inhibited.	21
Input shaft speed sensor	Open or short-circuit	No output pulse from the input shaft speed sensor is detected for 1 second or more when the vehicle speed is 30 km/h or more.	The diagnosis code is output if the judgement condition occurs once. The solenoid valve is energized and the N range lamp flashes as in fail-safe mode when the judgement condition is detected 4 times.	22
Output shaft speed sensor	Open or short-circuit	Output from the output shaft speed sensor is continuously 50% or less of the output from the vehicle-speed sensor for 1 second or more when the vehicle speed is 30 km/h or more.		23



Item		Judgement condition	Backup	Diagnosis code No.
Stop lamp switch	Short-circuit	Stop lamp switch is continuously on for 5 minutes or more when the vehicle speed is 6 km/h or more.	INVECS-II is inhibited.	26
LR solenoid valve	Open or short-circuit	Solenoid valve resistances is too large or too small.	A/T control relay is turned off and N range lamp flashes.	31
UD solenoid valve	Open or short-circuit			32
2nd solenoid valve	Open or short-circuit			33
OD solenoid valve	Open or short-circuit			34
RED solenoid valve	Open or short-circuit			35
DCC solenoid valve	Open or short-circuit			36
Incomplete shifting	1st	Gear ratio value which is output from the output shaft speed sensor is not identical to the output from the input shaft speed sensor after shifting finishes.	The diagnosis code is output if the judgement condition occurs once. The control relay turns off and the N range lamp flashes when the judgement condition is detected 4 times.	41
	2nd			42
	3rd			43
	4th			44
	5th			45
	Reverse			46
Abnormal communication with engine-ECU or TCL-ECU		Communication is continuously irregular for 1 second when the ignition switch is on, the system voltage is 10 V or higher and the engine speed is 450 r/min or higher, or a communication abnormal signal is received continuously for 4 seconds under the same conditions.	Engine air intake pressure is assumed to be 80 kPa until a normal communication can be received. INVECS-II is inhibited. No transmission made until a normal communication can be received.	51
DCC solenoid valve	System malfunction	The DCC solenoid valve drive duty rate is 100% for a continuous period of 4 seconds or more.	The system is temporarily disconnected if the judgement condition occurs once. The system is disconnected and the diagnosis code is output when the judgement condition is detected 4 times.	52
A/T control relay	Open or short-circuit to earth	A/T control relay voltage is less than 7 V after the ignition switch is turned to ON.	A/T control relay turns off and N range lamp flashes	54
	Contact welding	Control relay voltage is 5 V or more before relay ON is instructed from A/T-ECU after ignition is turned ON.		55
N range light	Short-circuit to earth	After the N range lamp illuminates (ON indication), it does not illuminate again.	N range lamp drive instructions from the A/T-ECU are cancelled.	56
Low-speed gear shifting command given when driving at high speed		Operation of the 1st gear solenoid valve is detected at an output shaft speed of 2,000 r/min or more, or operation of the 2nd gear solenoid valve is detected at an output shaft speed of 3,750 r/min or more.	A/T control relay is turned off.	-
Abnormality in A/T-ECU		Abnormality has occurred in A/T-ECU	A/T control relay is turned off.	71

**(2) Data list**

A/T-ECU input and output data are serially communicated to the diagnosis connector. These

data can therefore be read by connecting the MUT-II to the diagnosis connector.

**Data reference table**

Data list No.	Item	Unit
11	Throttle position sensor <vehicles without TCL>	mV
	Accelerator pedal position sensor <vehicles with TCL>	mV
15	Oil temperature sensor	°C
21	Crank angle sensor	r/min
22	Input shaft speed sensor	r/min
23	Output shaft speed sensor	r/min
26	Stop lamp switch	ON/OFF
29	Vehicle-speed sensor	km/H
31	LR solenoid valve duty rate	%
32	UD solenoid valve duty rate	%
33	2ND solenoid valve duty rate	%
34	OD solenoid valve duty rate	%
35	RED solenoid valve duty rate	%
36	DCC solenoid valve duty rate	%
52	Damper clutch slip amount	r/min
54	A/T control relay output voltage	V
58	Engine intake manifold negative pressure	kPa
61	Inhibitor switch	P/R/N/D
63	Shift position	5th/4th/3rd/2nd/1st/REV./N. P
64	Idle position switch	ON/OFF
65	Dual pressure switch	ON/OFF
67	Sports-mode select switch	ON/OFF
68	Sports-mode upshift switch	ON/OFF
69	Sports-mode downshift switch	ON/OFF

**(3) Actuator test**

Actuators can be force-driven by sending signal from the MUT-II to the A/T-ECU.

**Actuator test table**

Item No.	Actuator	Test contents	Test requirements
1	LR solenoid valve	drives the solenoid valve designated by the MUT-II for five seconds at a rate of 50-percent duty. The other solenoid valves are not energized.	(1) Ignition switch: ON (2) Selector lever: P range (3) Engine speed: 0 r/min (4) Vehicle speed: 0 km/h (5) Throttle (accelerator) opening voltage: less than 1 V (6) Idle position switch: ON
2	UD solenoid valve		
3	2ND solenoid valve		
4	OC solenoid valve		
5	RED solenoid valve		
6	DCC solenoid valve		
7	1st-gear shift indicator lamp	lights up the gear shift indicator lamp designated by the MUT-II for three seconds.	
8	2nd-gear shift indicator lamp		
9	3rd-gear shift indicator lamp		
10	4th-gear shift indicator lamp		
11	5th-gear shift indicator lamp		
12	A/T control relay	turns off the A/T control relay for three seconds	

**(4) INVECS-II cancel command**

Operation of the INVECS-II can be cancelled by sending a signal from the MUT-II to the A/T-ECU. (This continues until the ignition switch is turned to OFF.)

Item No.	Item	Contents
14	INVECS-II	INVECS-II control is cancelled and shifting is carried out according to the standard shift pattern.

**TRANSMISSION CONTROL**

A sports mode that allows quick up and down-shifting just by moving the lever forward and

backward has been incorporated for the selector lever assembly.

**CONSTRUCTION DIAGRAM**

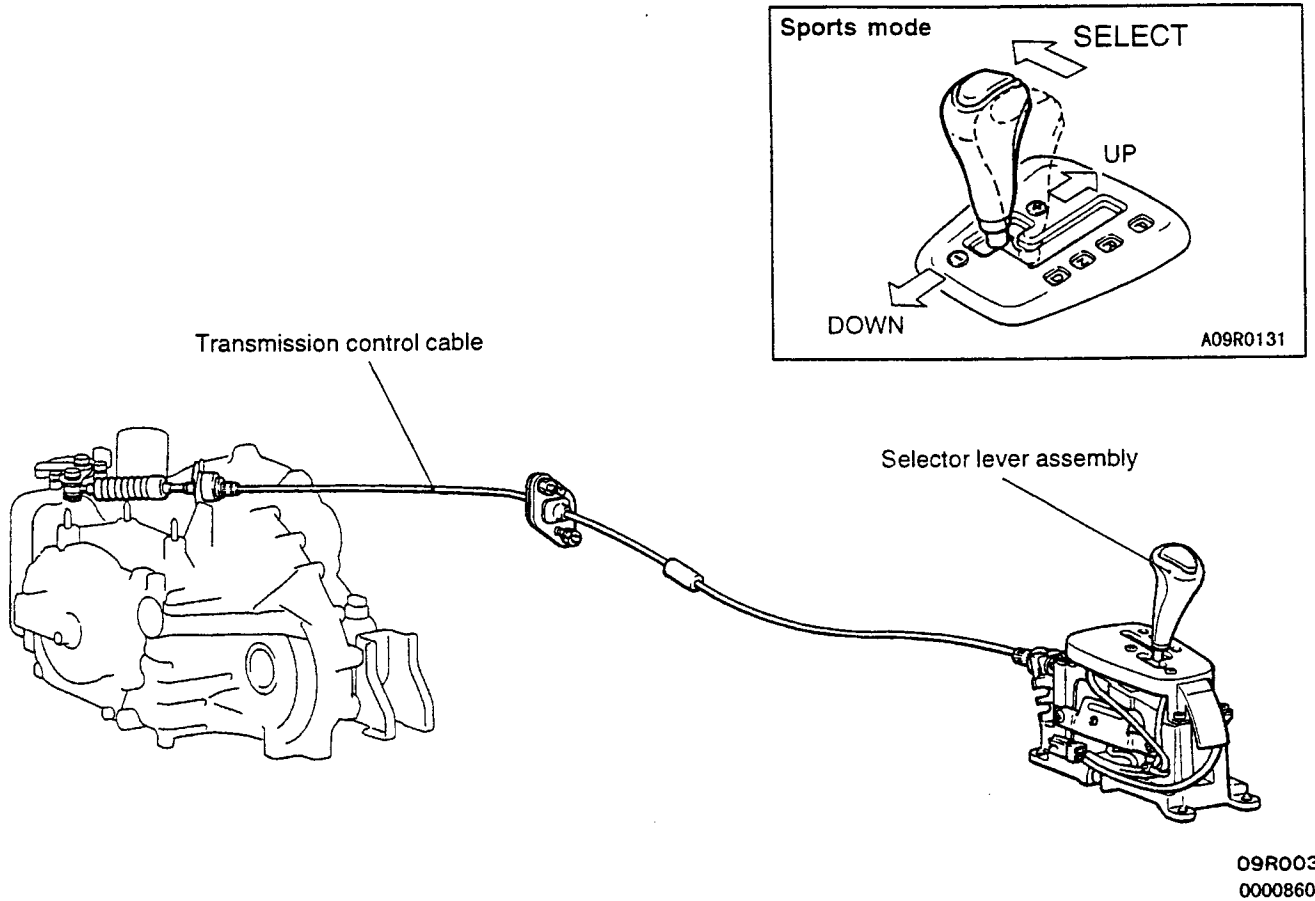

09R0033  
0008604

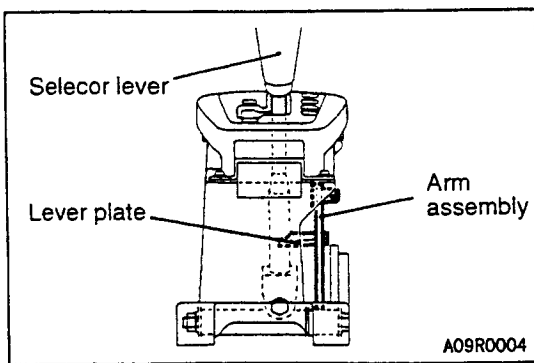

**CONSTRUCTION AND OPERATION**

**Operation of transmission control cable**

**A/T mode (P, R, N, D) position**

When the selector lever is at the P, R, N or D position, the lever plate is engaged with the arm assembly. Thus, when the selector lever is moved, the lever and arm assembly move simultaneously, and the transmission control cable connected to the arm assembly moves.

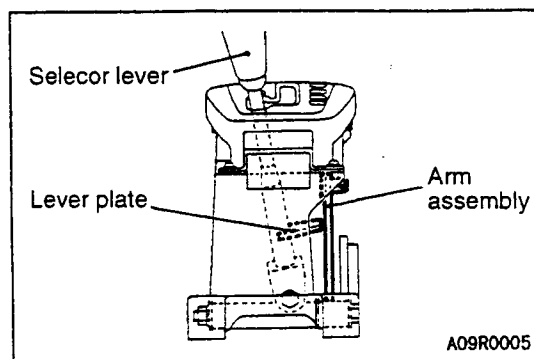

**Sports mode (+, -) position**

When the selector lever is moved to the sports mode position from the D range, the lever plate and arm assembly are disengaged, and the transmission control cable will not move even if the selector lever is moved to the up or down side.

## FRONT AXLE

### FEATURES

- For the drive shaft, the B.J.-T.J. type constant velocity joint has been adopted which offers high transmission efficiency and causes little vibration and noise.
- A dynamic damper has been mounted on the right drive shaft of all vehicles to reduce the vibration.
- The hub knuckle has a structure in which the wheel bearings are assembled into the knuckle

and the front hub is press-fit in. The drive shaft and hub are linked with serration.

- Five hub bolts have been used due to the incorporation of a large diameter flat tire, and improved output performance.

**NOTE**

B.J.: Birfield Joint, T.J.: Tripod Joint

### SPECIFICATIONS

Items		Specifications
Wheel bearing	Type	Double-row angular contact ball bearing
	Outside diameter × inside diameter mm	80 × 40
Drive shaft	Type	B.J.-T.J.
	Length (joint to joint)	L.H.: 381, R.H.: 701

### CONSTRUCTION DIAGRAM

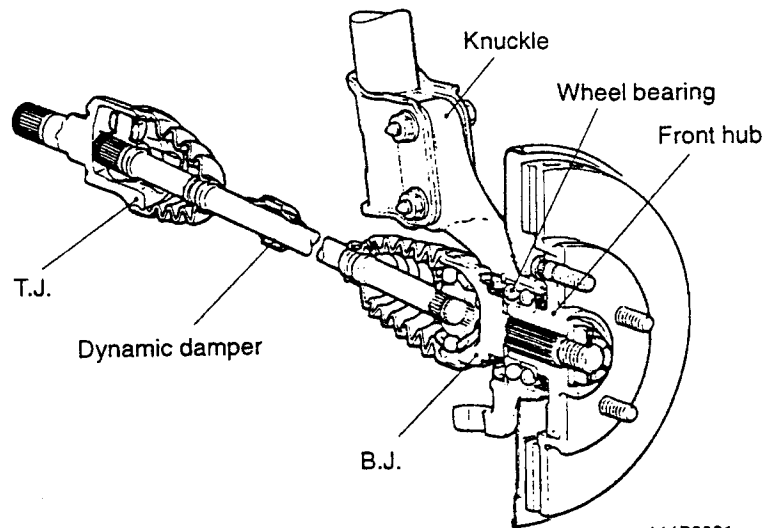

A11R0001

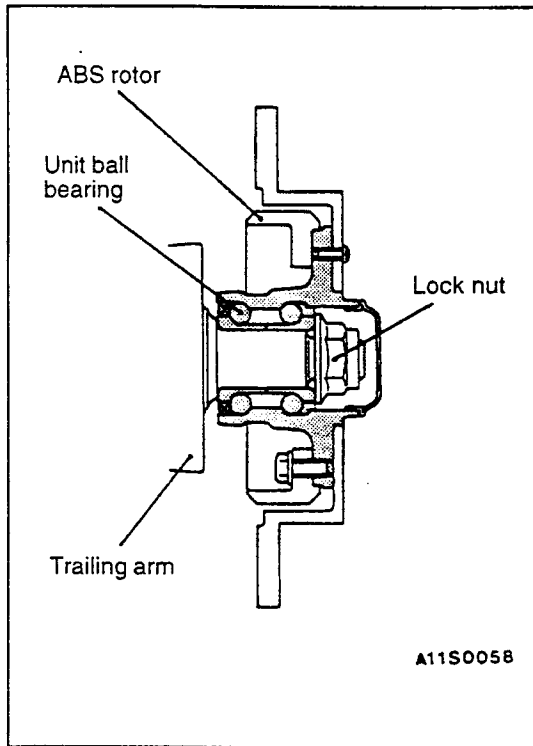

## REAR AXLE

Unit ball bearings are adopted for the wheel bearing to lighten and downsize the unit.

An ABS rotor for wheel-speed detection has been incorporated in the hub.

As with the front axle, five hub bolts are used.

# DRIVE-CONTROL COMPONENTS

## CONTENTS

<b>SUSPENSION</b> .....	<b>2</b>	Construction Diagram .....	11
Features .....	2	Specifications .....	12
<b>FRONT SUSPENSION</b> .....	<b>3</b>	Construction .....	13
Construction Diagram .....	3	1. Master Cylinder .....	13
Specifications .....	4	2. Brake Booster .....	13
<b>REAR SUSPENSION</b> .....	<b>5</b>	3. Disc Brake .....	14
Construction Diagram .....	5	<b>ANTI-LOCK BRAKE SYSTEM (ABS)</b> .....	<b>15</b>
Specifications .....	5	Construction Diagram .....	15
<b>WHEEL AND TYRE</b> .....	<b>6</b>	Major Components and Function .....	15
<b>POWER STEERING</b> .....	<b>6</b>	Schematic Diagram .....	16
Specifications .....	6	ABS Electrical Circuit Diagram .....	17
Construction Diagram .....	7	ABS Fluid Pressure Diagram .....	18
Construction and Operation .....	8	Construction and Operation .....	19
1. Steering Wheel and Column .....	8	1. Sensor .....	19
2. Oil Pump .....	10	2. Actuator .....	19
<b>SERVICE BRAKES</b> .....	<b>11</b>	3. ABS-ECU .....	21
Features .....	11	<b>PARKING BRAKES</b> .....	<b>28</b>
		Construction Diagram .....	28

## SUSPENSION

The McPherson strut front suspension has been adopted. To increase the rigidity of the suspension installation, a No.2 crossmember has been mounted.

The rear suspension is a trailing arm type multilink suspension.

### FEATURES

High Steering  
Stability

1. Use of 4-wheel independent suspension
2. Use of wide tread
3. Optimum suspension geometry
4. Use of pillow ball type stabilizer link

Enhanced Riding  
Comfort

1. Use of offset coil spring
2. Use of large strut insulators
3. Use of low friction front lower arm ball joint
4. Use of stabilizer bushing containing lubricant

Upgraded  
Serviceability

1. Use of a camber and toe adjustment mechanism in the rear suspension

Improved Rigidity

1. Use of No.2 crossmember to front suspension
2. Optimum layout of front lower arm supporting section to increase horizontal rigidity



## FRONT SUSPENSION

The conventionally popular McPherson strut front suspension has been adopted to ensure optimum alignment and various geometries that provide excellent controllability, stability and riding comfort.

In addition, a pipe structure No.2 crossmember has been incorporated to enhance the suspension rigidity, enlarge the tread, and improve controllability, stability and advance stability.

### CONSTRUCTION DIAGRAM

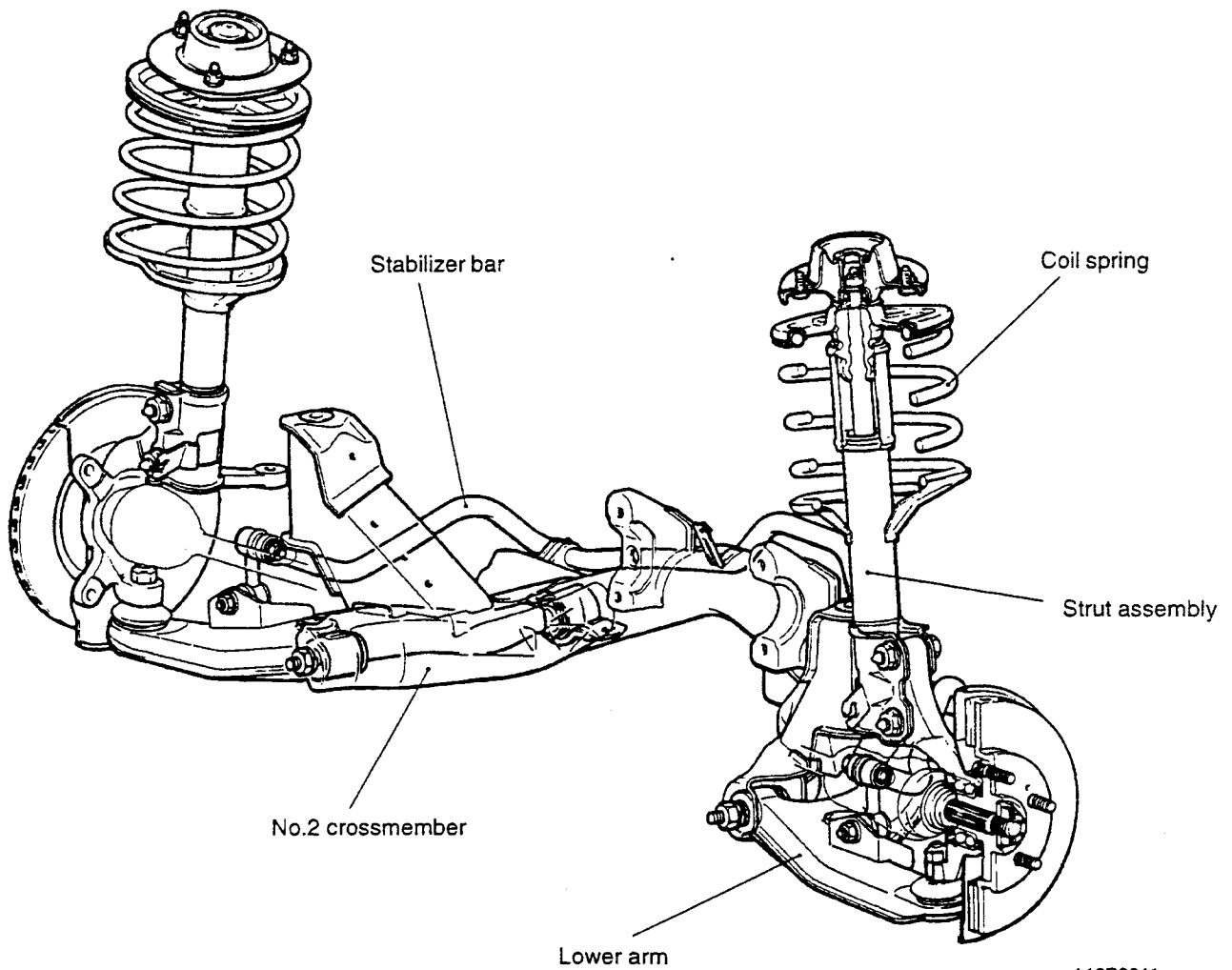

A12R0041

## SPECIFICATIONS

Items		Specifications	
Wheel alignment	Camber	-0°30'	
	Caster	2°50'	
	Kingpin inclination	14°10'	
	Toe-in mm	0	
Coil spring	Wire diameter × coil average diameter × free length mm	13 × 160 × 301	
	Spring constant N/mm	31.4	
	Identification colour	Yellow/Light blue	
Shock absorber	Type	Hydraulic, cylindrical double acting type (low pressure gas sealed method)	
	Stroke mm	164	
	Damping force N (at 0.3 m/sec.)	Expansion	1,667
		Contraction	490
Stabilizer bar	O.D. mm	16	
	Identification colour	Blue	

## REAR SUSPENSION

The rear suspension is a trailing arm type multi-link suspension. This suspension has the following features, allowing an operation performance and stability that fully uses the features of the tyre to be used.

- Characteristics of double wishbone type having small camber changes

- Characteristics of trailing arm without outstanding riding comfort
- Characteristics that optimally control changes in toe due to vertical oscillations and forward/backward forces induced in the suspension

### CONSTRUCTION DIAGRAM

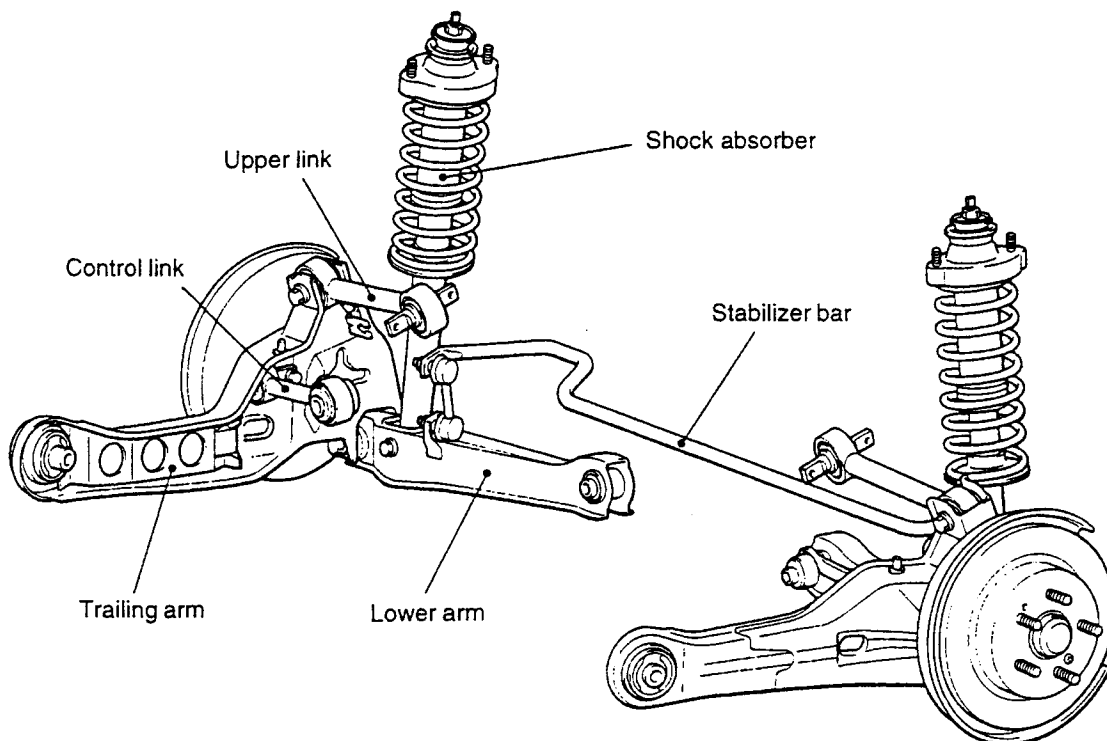

A12R0003

### SPECIFICATIONS

Items		Specifications
Wheel alignment	Camber	-1°
	Toe-in mm	3
Coil spring	Wire diameter × coil average diameter × free length mm	10 × 86 × 317
	Spring constant N/mm	21.6
	Identification colour	Green/Brown
Shock absorber	Type	Hydraulic, cylindrical double acting type (low pressure gas sealed method)
	Stroke mm	165
	Damping force N (at 0.3 m/sec.)	Expansion
Contraction		392
Stabilizer bar	O.D. mm	18
	Identification colour	Red

## WHEEL AND TYRE

- A 16 x 6 1/2 JJ (offset amount 38 mm) aluminum wheel has been incorporated.
- A lightweight thin type high-pressure spare tyre T125/70D16 has been used.

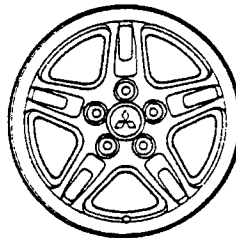

A00R0005

## POWER STEERING

- Steering wheel ..... A 3-spoke type steering wheel has been set. The SRS air bag has been mounted in all models.  
[For information on the SRS, refer to the "Interior – Supplemental Restraint System" section.]
- Steering column ..... The tilt steering mechanism and steering column with shock absorbing mechanism have been incorporated in all models.
- Oil pump ..... The oil pump uses the vane type oil pump with fluid flow control system that changes the steering force according to the engine speed.
- Steering gear and linkage ..... The steering gear and linkage system incorporates the highly reliable, lightweight and compact integral rack and pinion type power steering.

## SPECIFICATIONS

Items		Specifications
Steering wheel	Type	3-spoke
	O.D. mm	375
	Maximum turns	2.64
Steering column		Tilt steering mechanism
Power steering type		Integral type (engine speed sensitivity method)
Power steering	Gear type	Rack and pinion
	Stroke ratio (rack stroke/steering wheel maximum turns)	51.45
	Rack stroke mm	136
Oil pump	Type	Vane type with fluid flow control system
	Displacement ml/rev.	9.6
	Relief set pressure kPa	8,800
	Pressure switch	Equipped
Steering angle	Inner wheel	37°
	Outer wheel	30°

CONSTRUCTION DIAGRAM

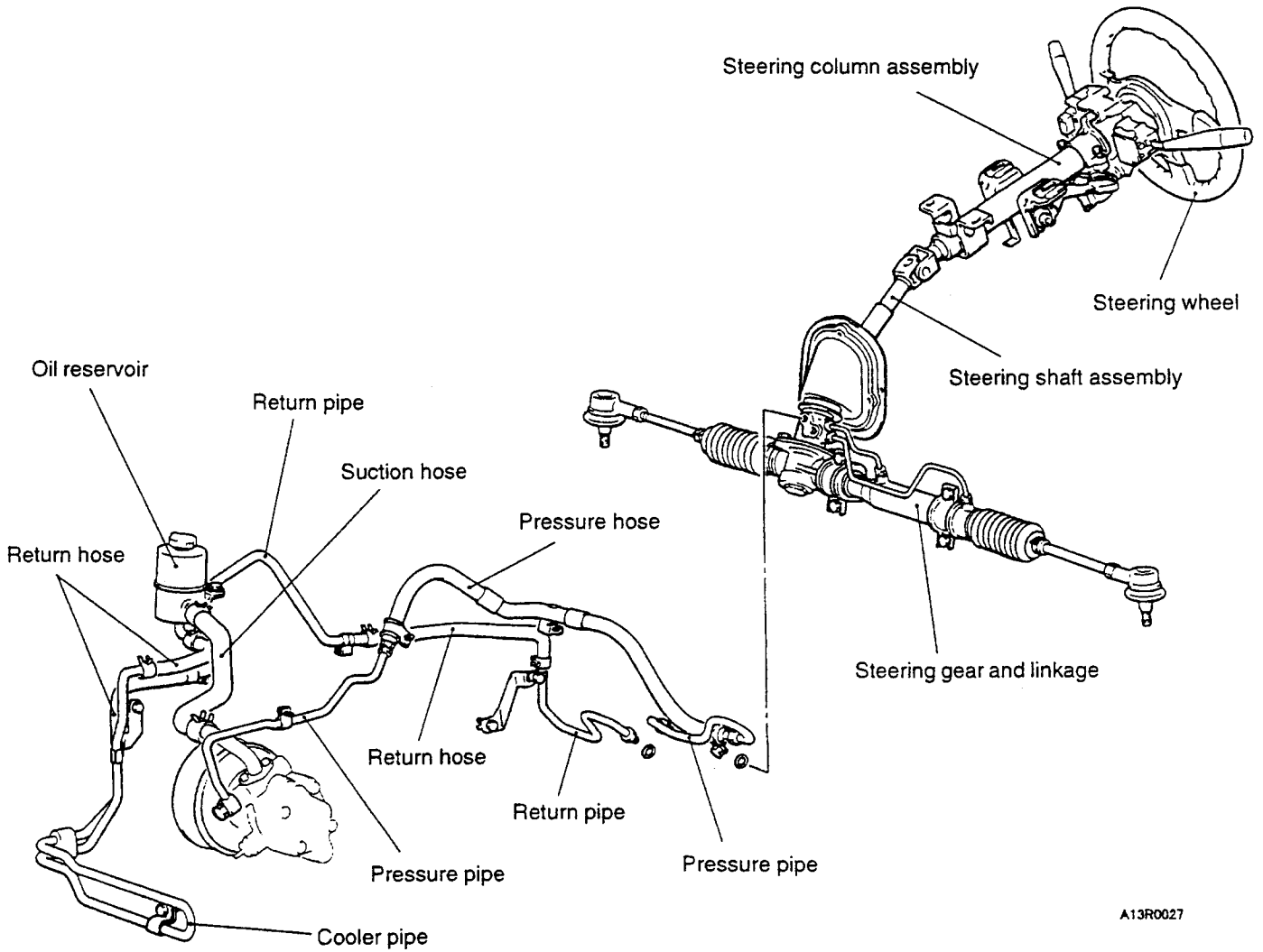

A13R0027

CONSTRUCTION AND OPERATION

1. Steering Wheel and Column

- The MOMO leather bound 3-spoke steering wheel with air bag built in has been incorporated.

MOMO leather bound

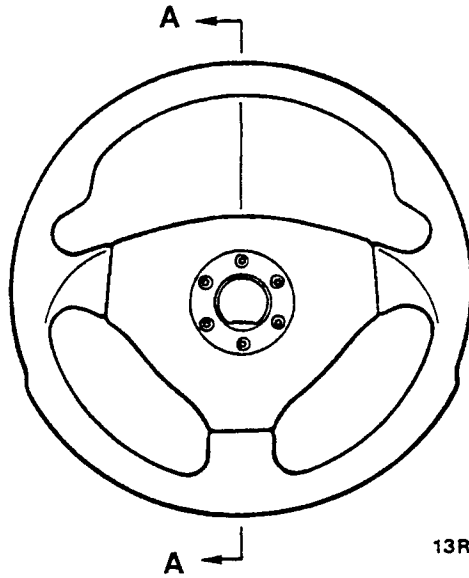

13R0025

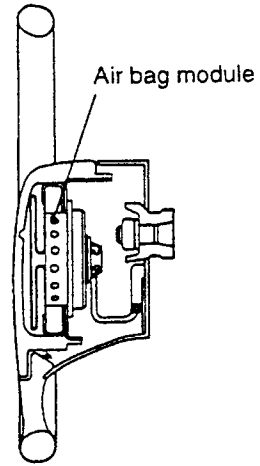

13M0017  
00008621

Cross section A - A

**STEERING SHAFT AND COLUMN**

A tilt steering mechanism that allows the optimum driving position to be obtained, and a steering column with shock absorbing mechanism to absorb

shock energy when there is a collision are incorporated.

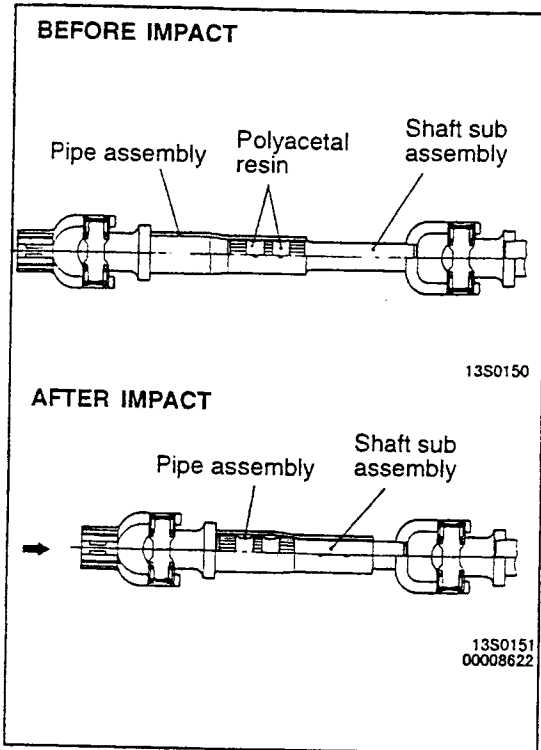

**Shock Absorbing Mechanism**

**Primary shock**

When the collision energy of the vehicle is transmitted to the steering shaft via the steering gear box, it will be absorbed by crushing the polyacetal resin and sliding the shaft sub assembly into the pipe assembly. This prevents the steering column from moving backward.

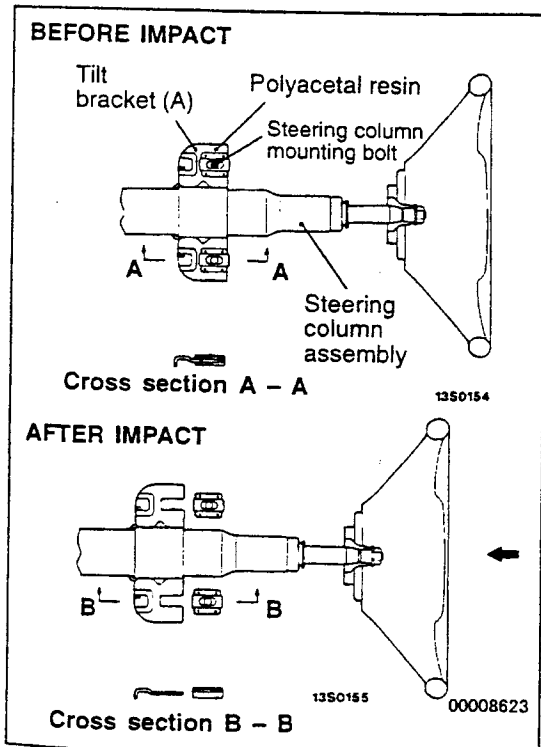

**Secondary shock**

- (1) When the driver's body falls against the deployed air bag, the tilt bracket (A) moves forwards by crushing the polyacetal resin, causing the steering column to move forward and down.

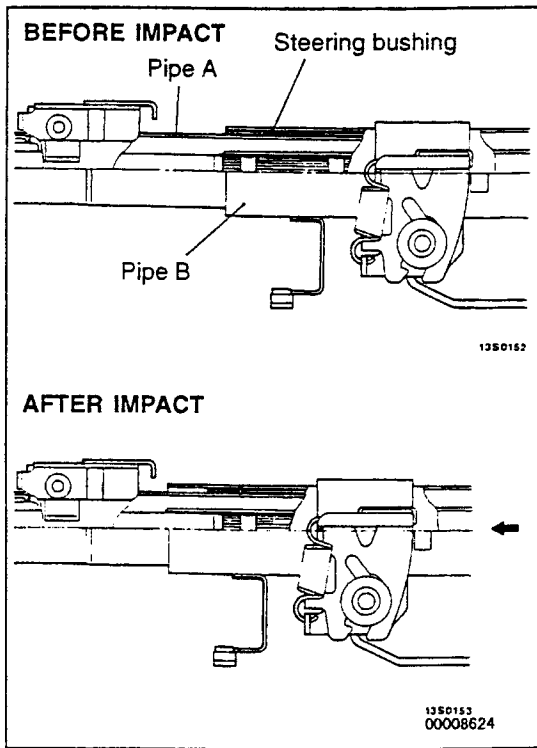

(2) When the pipe B slides forward, the ball inside the steering column bushing absorbs the shock by rolling resistance between pipes A and B.

2. Oil Pump

The engine speed sensitivity method is incorporated for the oil pump, and the pump performance is set so that an optimum steering force and smooth

steering feeling can be obtained. Furthermore, the steering force lays high importance on the steering reaction force at high speeds.

OIL PUMP PERFORMANCE

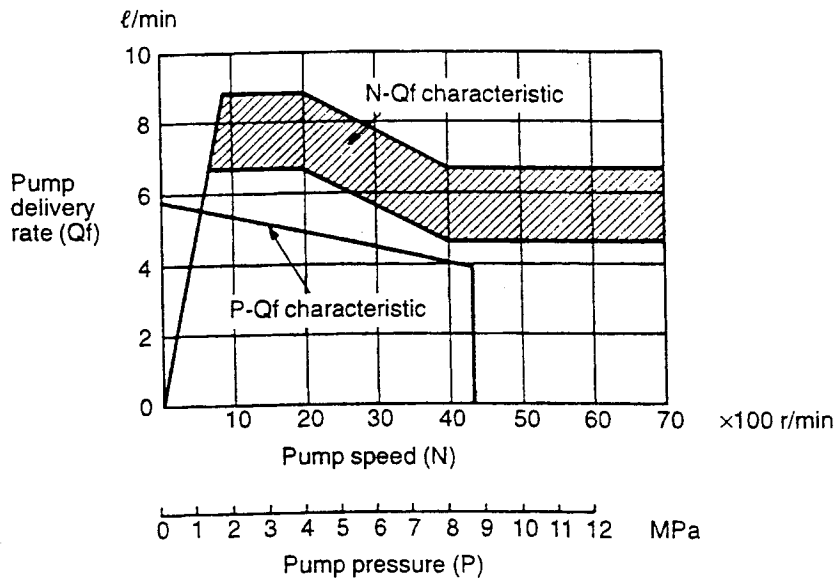

A13R0010

NOTE

- (1) P-Qf characteristic: Pump pressure and pump delivery rate
- (2) N-Qf characteristic: Pump speed and pump delivery rate



## SERVICE BRAKES

The brake system offers high dependability and durability along with improved braking performance.

### FEATURES

Improved braking performance

1. A 4-wheel disc brake is used.
2. A 15-inch 2-pot ventilated disc brakes are adopted for the front brake.
3. An anti-lock brake system (ABS) that prevents skidding from locked wheels during braking, and ensures directional stability and operability has been set.
4. A tandem brake booster has been adopted which provides powerful braking with a light foot pressure.

Improved serviceability

1. For ease of inspection, a diagnosis capacity has been adopted for the ABS.
2. A separate structure from the hub has been incorporated for the brake disc for easy removal and installation.
3. The master cylinder reserve tank cap is white for easy recognition.

Higher safety

1. Load sensing proportioning valves prevent the rear wheels from locking too quickly.
2. Front and rear X brake lines.
3. An audible wear indicator alerts the driver to the brake pad limit.

### CONSTRUCTION DIAGRAM

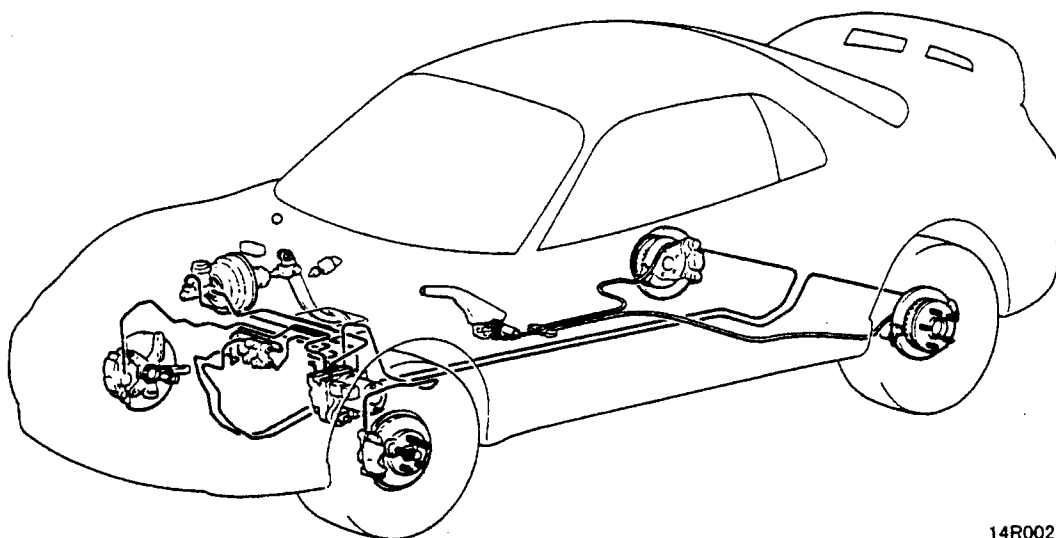

14R0028

## SPECIFICATIONS

Items		Specifications	
Master cylinder	Type	Tandem type	
	I.D. mm	25.40	
Brake booster	Size inch	7 + 8	
	Effective dia. of power cylinder mm	180 + 205	
	Boosting ratio	6.0	
Proportioning valve	Type	Dual type	
	Split point kg/cm <sup>2</sup> (crossover reference value)	25 ±2.5	
	Decompression ratio	0.25	
Front brakes	Type	Floating caliper, dual piston (2-pot), ventilated disc	
	Disc effective dia. × thickness mm	227.8 × 24	
	Wheel cylinder I.D. mm	42.86 × 2	
	Pad thickness mm	10.0	
	Clearance adjustment	Automatic	
Rear brakes	Type	Floating caliper, single piston (1-pot), solid disc	
	Disc effective dia. × thickness mm	224 × 10	
	Wheel cylinder I.D. mm	30.16	
	Pad thickness mm	9.5	
	Clearance adjustment	Automatic	
ABS	Rotor teeth	Front side	43
		Rear side	43
	Speed sensor type		Magnet coil type

**CONSTRUCTION**

**1. Master Cylinder**

The master cylinder offers the following features.

- A tandem type master cylinder.
- A filter is provided in the reserve tank to prevent foreign matter from entering when adding or replacing brake fluid.
- The reserve tank cap is white for easy recognition which improves serviceability.

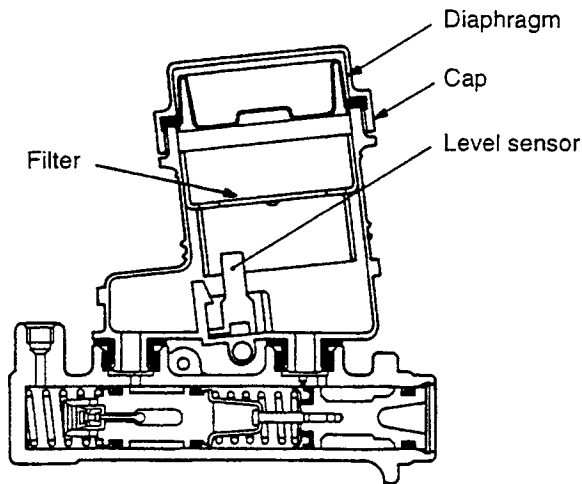

A14R0020

**2. Brake Booster**

The vehicle is equipped with a 7+8-inch tandem type brake booster.

The tandem type brake booster uses two diaphragms to double the power effect resulting

from the pressure difference between the atmospheric pressure and the negative pressure. It ensures an augmented brake boosting power without increasing the outside diameter.

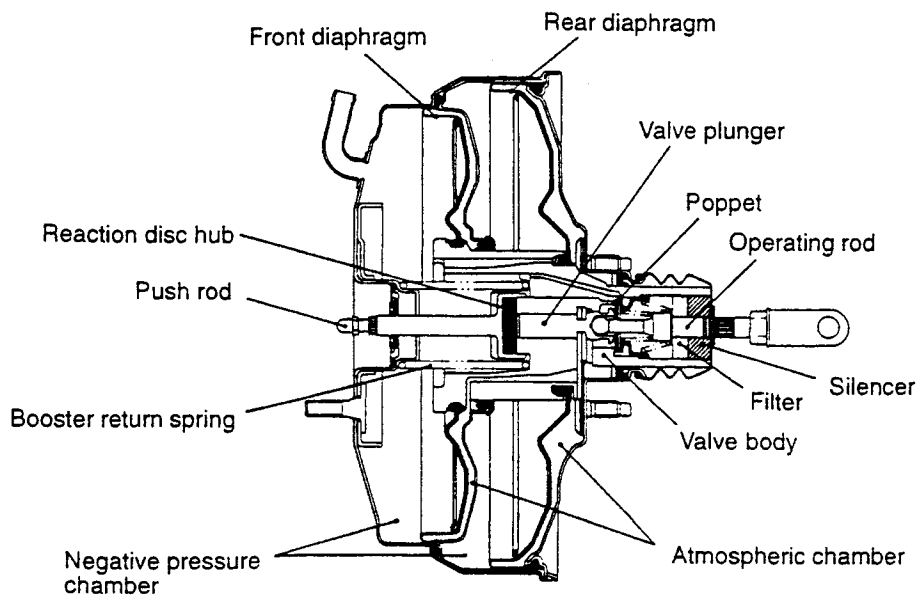

A14F0091

3. Disc Brake

- (1) Dual piston ventilated disc brakes are incorporated for the front brakes.
- (2) Single piston solid disc brakes are adopted for the rear brakes.
- (3) The disc brake mounting has been separated from the hub to improve workability.
- (4) An audible wear indicator to alert the driver that the brake pad wear limit has been reached is mounted on the front brakes.

<FRONT>

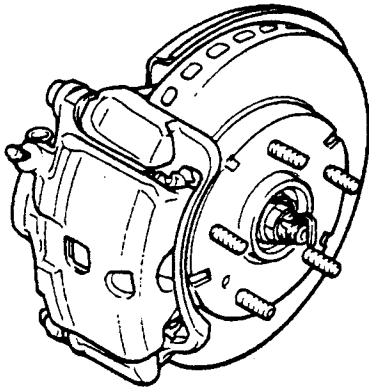

14R0022

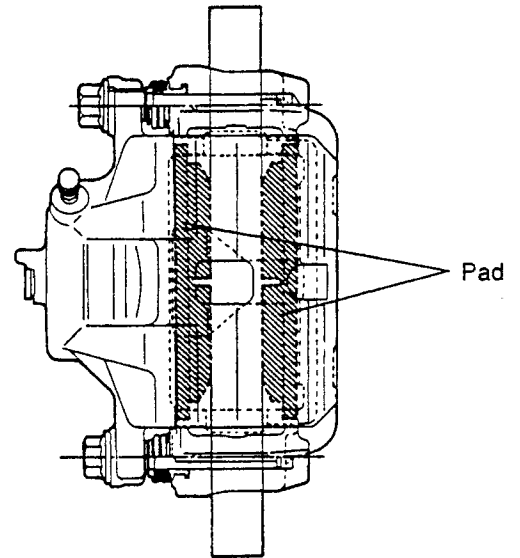

14S0032

<REAR>

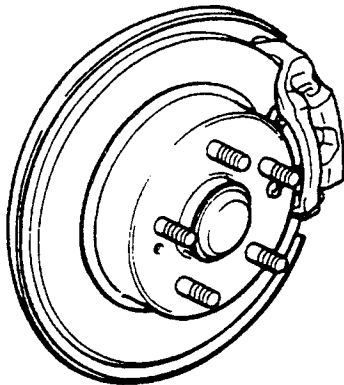

14R0027

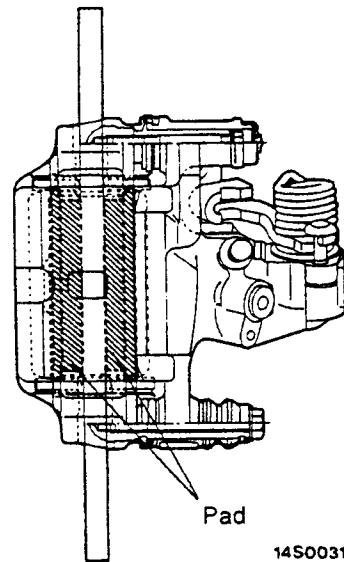

14S0031  
00008625

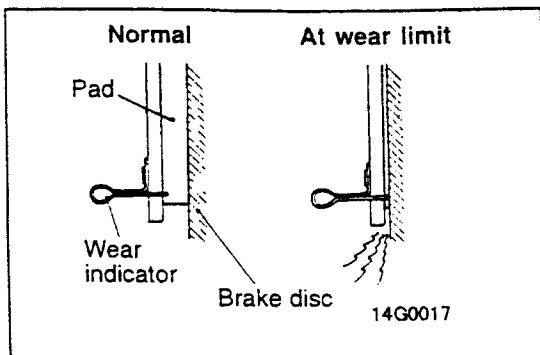

## ANTI-LOCK BRAKE SYSTEM (ABS)

The ABS detects skids that could be caused by emergency braking on a slippery road surface, and adequately controls the brake fluid pressure to prevent the wheels from locking. Therefore, the vehicle retains its directional stability and steerability. This ABS is basically the same as the conventional system.

Even if trouble occurs in the system, the fail-safe function will operate, and the normal braking force will be ensured. The serviceability has also been improved with the diagnostic function.

For the ABS, a wheel speed sensor and 4-sensor 4-channel system having a circuit to control the fluid pressure are adopted for all wheels.

### CONSTRUCTION DIAGRAM

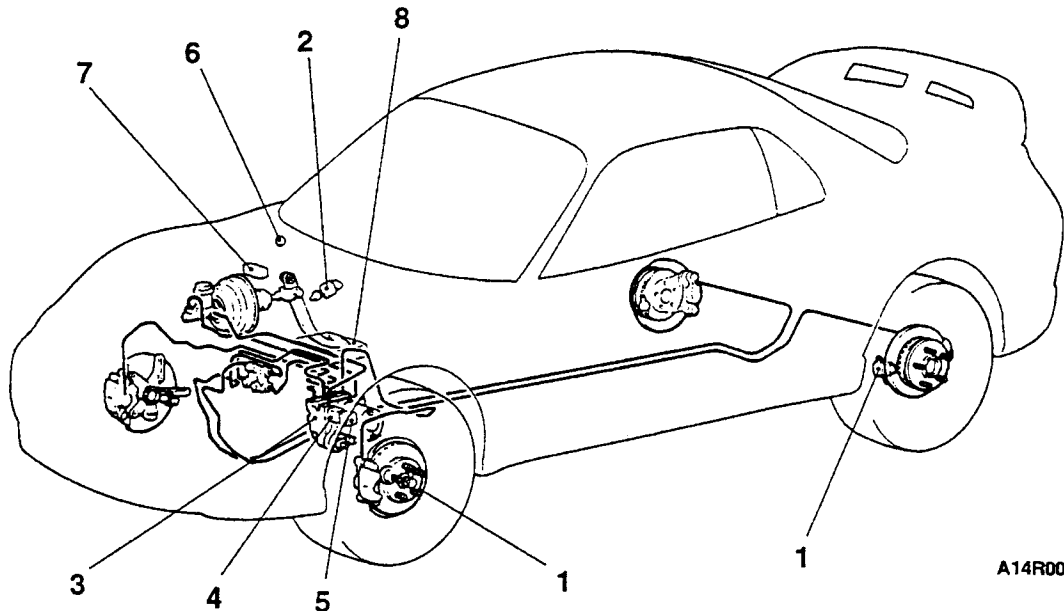

A14R0024

### MAJOR COMPONENTS AND FUNCTION

Component		No.	Function	Reference page
Sensors	Wheel speed sensor	1	Sends an AC signal with a frequency proportional to the rotating speed of each wheel to the ABS-ECU.	P.3-19
	Stop lamp switch	2	Sends a signal indicating whether or not the brake pedal is in the depressed state to the ABS-ECU.	P.3-19
Actuators	Hydraulic unit	3	Controls the brake fluid pressure for each wheel in response to a signal from the ABS-ECU.	P.3-19
	ABS motor relay	4	Closes the contact in response to a signal from the ABS-ECU and supplies power to the motor in the hydraulic unit.	P.3-20
	ABS valve relay	5	Closes the contact in response to a signal from the ABS-ECU and supplies power to the solenoid valve in the hydraulic unit.	P.3-20
	ABS warning lamp	6	Located in the combination meter, it warns the driver of a system failure.	P.3-20
	Diagnosis connector	7	Diagnosis codes are output through this connector.	P.3-25
ABS electronic control unit (ABS-ECU)		8	Controls the hydraulic unit and other actuators in response to the signals from the individual sensors.	P.3-24
			Controls the self-diagnosis and fail-safe functions.	P.3-24
			Controls the diagnosis functions (available when the MUT-II is connected).	P.3-24

SCHEMATIC DIAGRAM

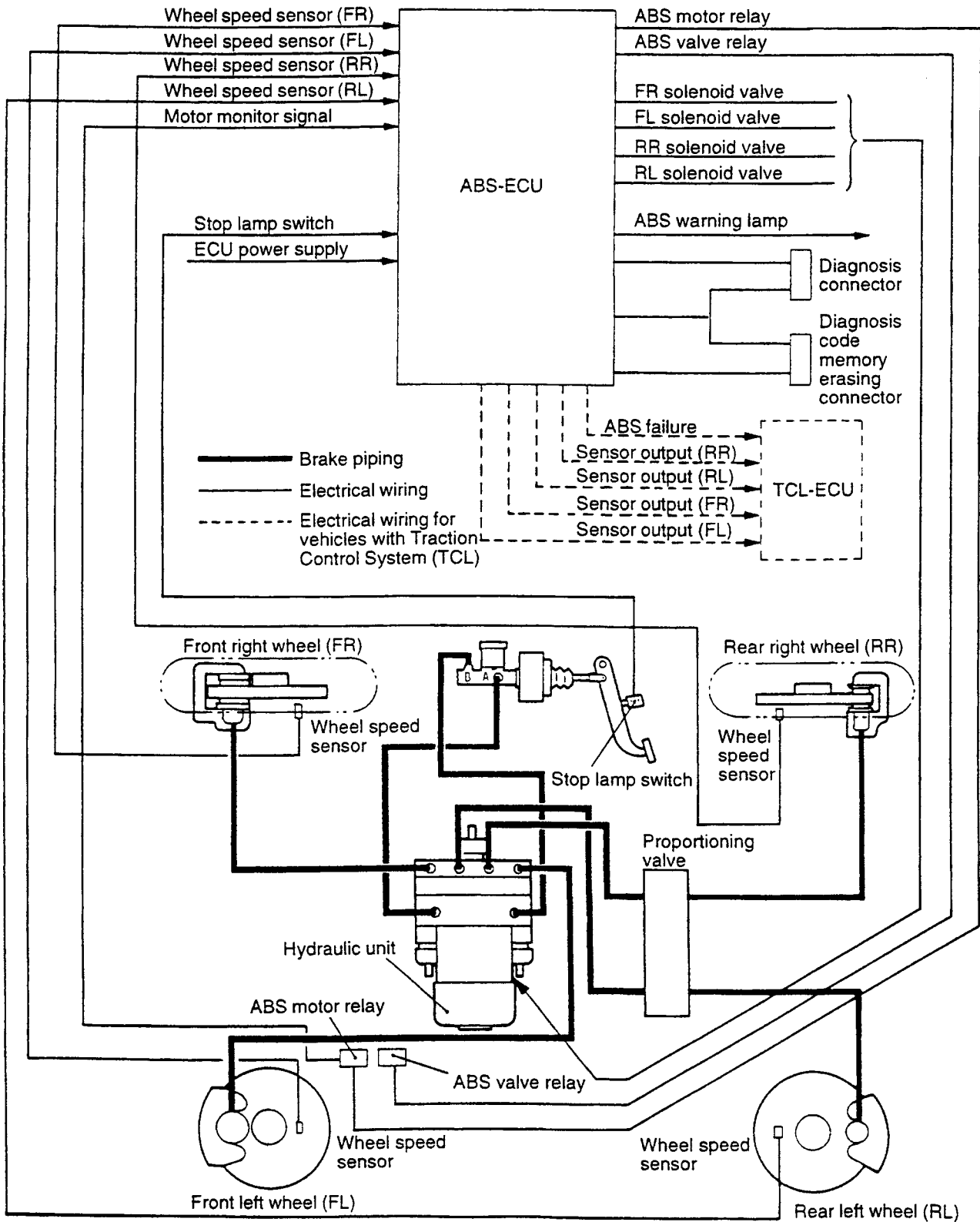

ABS ELECTRICAL CIRCUIT DIAGRAM

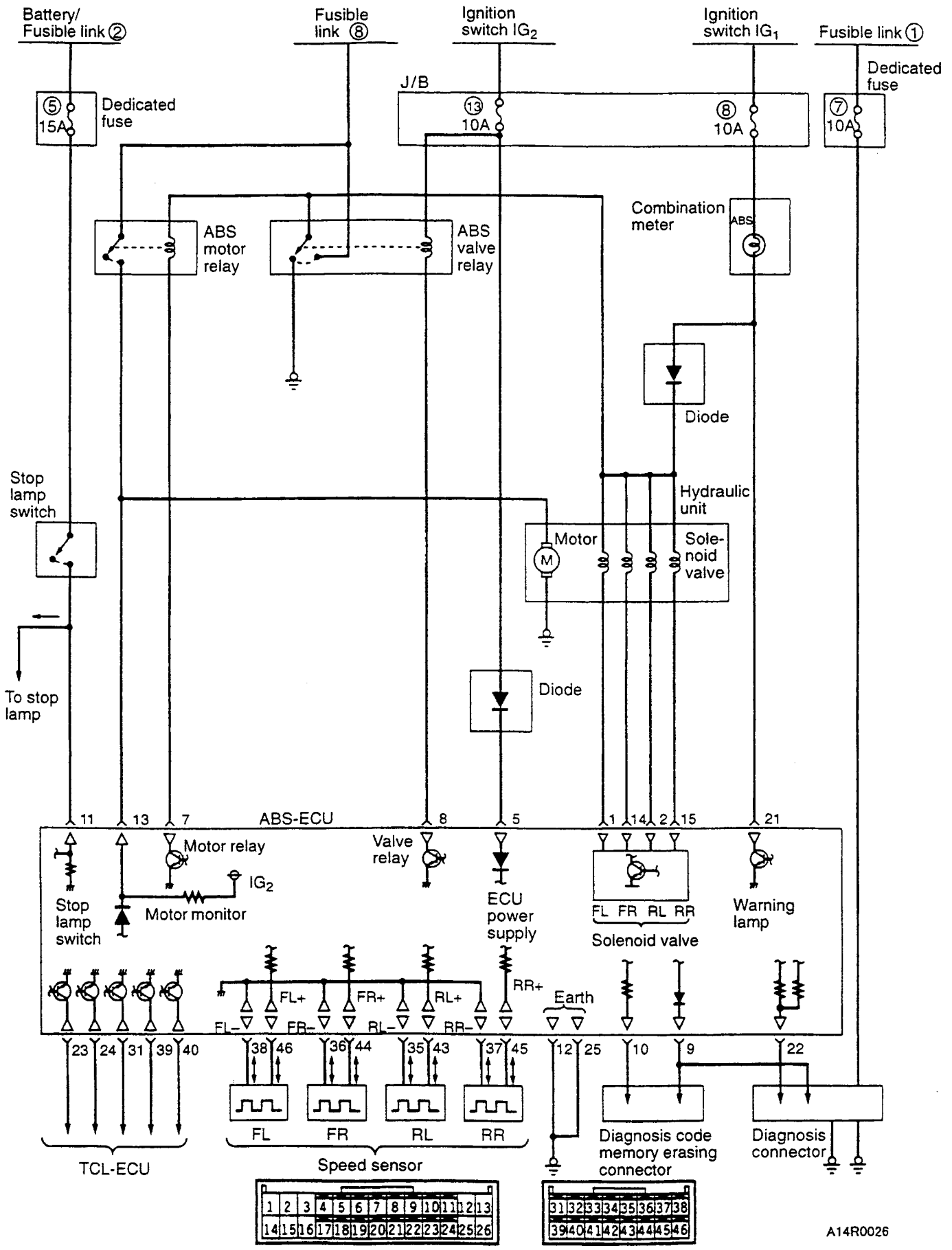

**ABS FLUID PRESSURE DIAGRAM**

For the ABS, left/right independent control is adopted for the front wheels, and a unified control (select low control\*) 4-sensor 4-channel system (four wheel speed sensors and four circuits to control the fluid pressure) is adopted for the rear wheels.

**NOTE**

\*Select low control: The speed of the left and right wheels are compared, and the same fluid pressure control is applied on the left and right wheels to match the wheel that may lock.

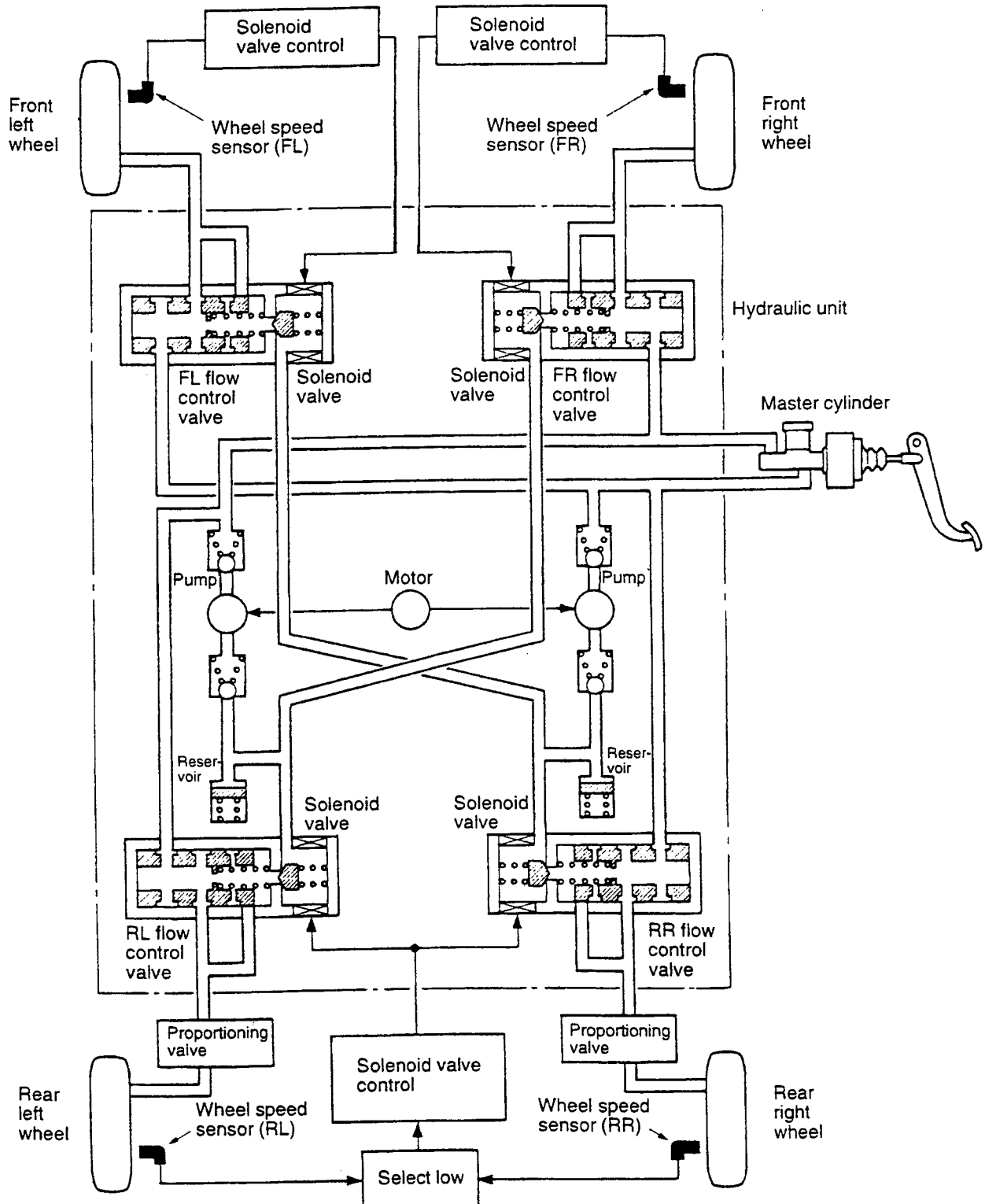



## CONSTRUCTION AND OPERATION

### 1. Sensor

#### WHEEL SPEED SENSOR

The wheel speed sensor is a pulse generator consisting of a ABS rotor rotating at the same speed as the wheel and a speed sensor secured to the body (knuckle or dust shield). Its basic construction and operating principles are the same as those of the previous system.

- For front wheels, the ABS rotor is mounted on the drive shaft and the speed sensor mounted on the knuckle.

- For rear wheels, the ABS rotor is mounted on the rear hub, and the speed sensor mounted on the disc brake adaptor.
- The spacing between the sensor and ABS rotor is not adjustable on the front wheels.

#### FRONT

#### REAR

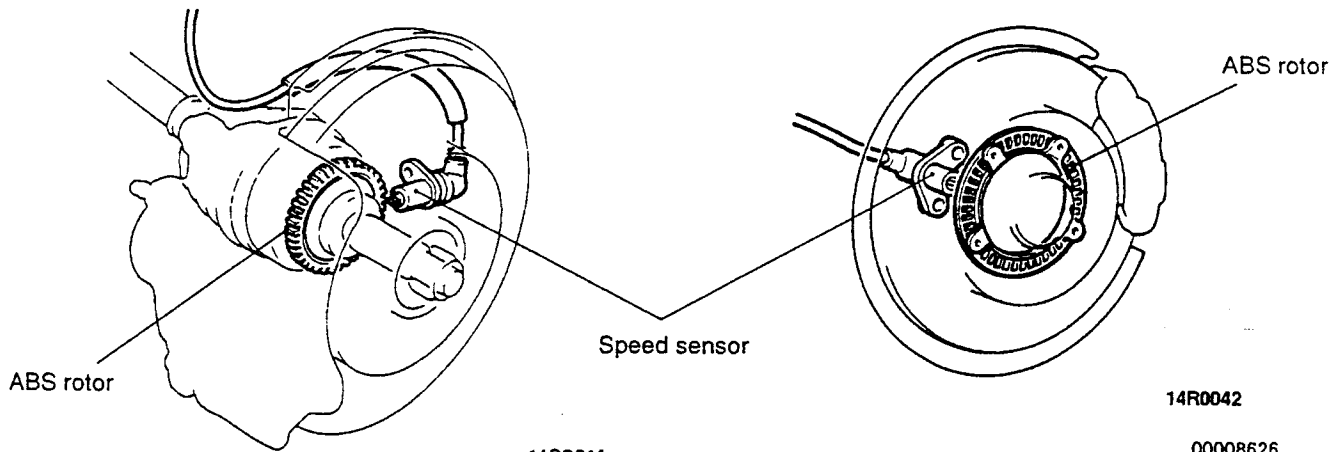

#### STOP LAMP SWITCH

When the brake pedal is depressed, the stop lamp turns ON, and when released, the lamp turns OFF. When ON, the battery voltage level is applied (HIGH), and when OFF, the voltage becomes approx. 0 V (LOW).

By monitoring this voltage, the ECU judges whether the brakes are being applied. This information is used as an assistant during ABS control.

### 2. Actuator

#### HYDRAULIC UNIT

The hydraulic unit consists of a motor and pump unit, solenoid valves, and a reservoir, and is

elastically supported by the dedicated bracket at the rear left section in the engine compartment.

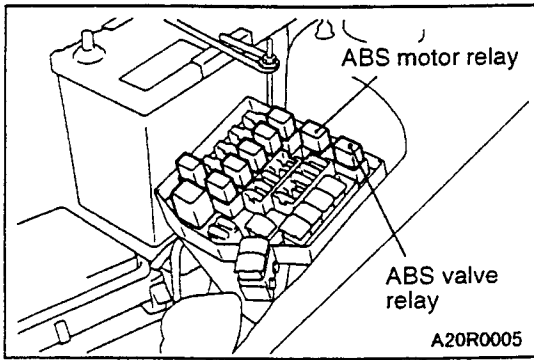

**ABS MOTOR RELAY**

The motor relay is used for ON/OFF control of the pump and motor in the hydraulic unit.

**ABS VALVE RELAY**

Motor relay has two normally-closed and normally-open contacts and functions as described below:

ABS valve relay	Hydraulic unit solenoid valve power supply	ABS warning lamp
When OFF	OFF	Illuminates
When ON	ON	Goes out

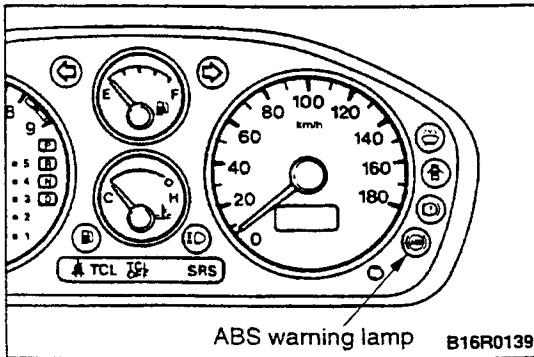

**ABS WARNING LAMP**

The ABS warning lamp illuminates in the following cases.

- (1) During the initial check performed when the ignition key is placed in the ON position. (Whether the lamp bulbs are burnt out can be checked.)
- (2) When a failure occurs in the ABS system (The illuminated state is held until the ignition switch is placed in the OFF position).

The ABS warning lamp also illuminates when the ECU power supply voltage drops, but the lamp will go out as soon as the high voltage is resumed.

### 3. ABS-ECU

- The ABS-ECU detects the vehicle speed in terms of a signal from the wheel speed sensor to determine the rotating condition of the wheel, estimates the skidding condition of the wheel on the basis of the pre-determined theory, and outputs a signal to move the solenoid valve in the hydraulic unit in such a way as to prevent locking the wheel.
- The ABS-ECU has diagnosis (self-diagnosis) and memory functions. If any failure is found by diagnosis, the fail-safe function is activated and the ABS warning lamp is illuminated.
- In the models equipped with TCL, the data from the wheel speed sensor of the rear wheel and the data indicating the ABS status are output.

#### BLOCK DIAGRAM

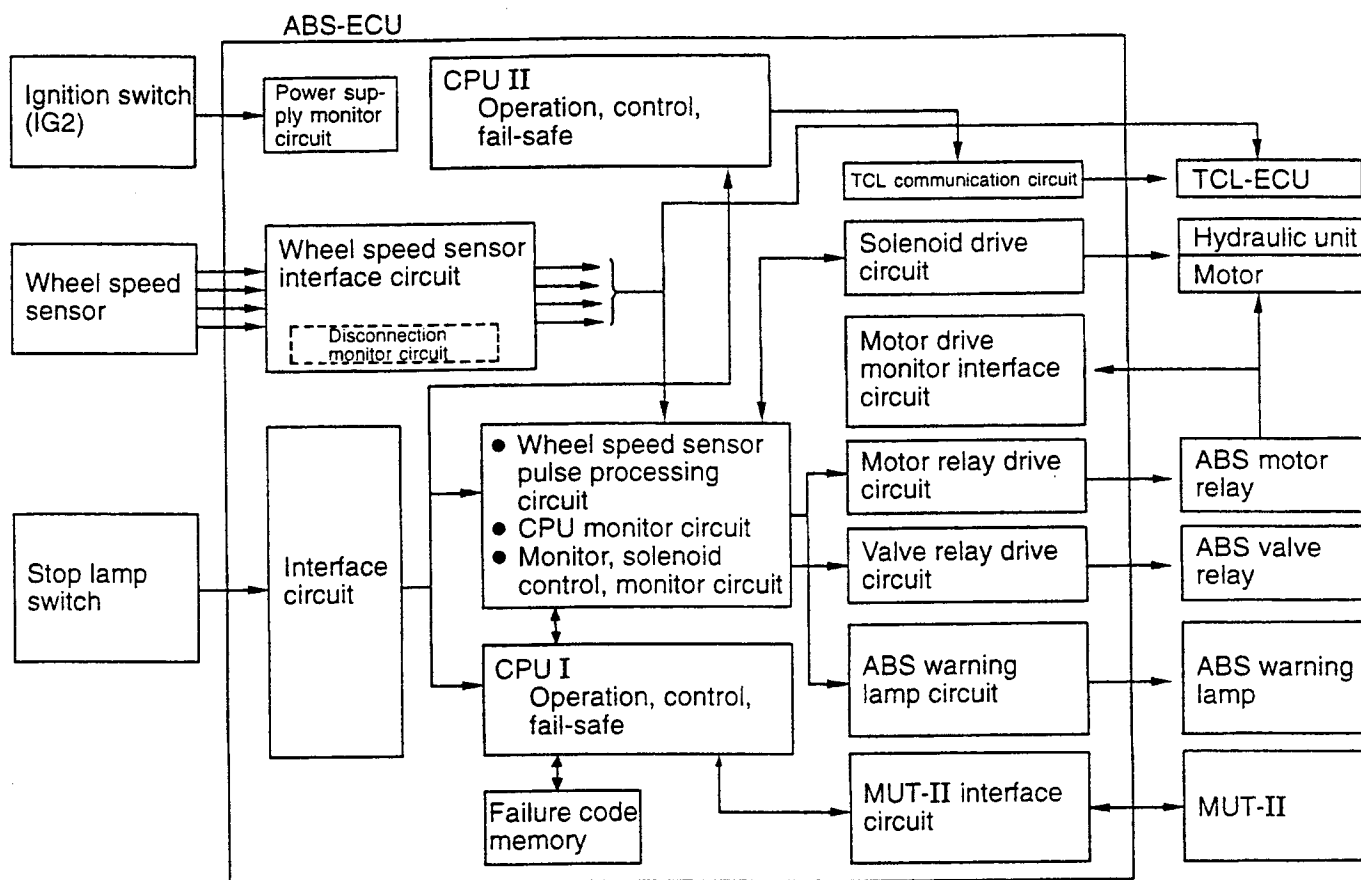

00008695

#### FUNCTIONS OF EACH CIRCUIT

- (1) The wheel speed sensor interface circuit is a circuit that converts the AC voltage signal into a DC pulse signal.
- (2) The power supply monitor circuit, switch input interface circuit and motor drive monitor interface circuit is the electrical conversion section for inputting the vehicle status such as the stop lamp switch state.
- (3) CPU I and CPU II are microcomputers. Based on the wheel speed signal input from the wheel speed sensor, various calculations including the wheel speed and wheel deceleration speed required for the anti-lock control is carried out, and anti-lock control based on these calculations are carried out. The CPU I and CPU II microcomputers monitor each other so that system failures can be detected. These also have self-diagnosis, and failure detection fail-safe functions, etc.
- (4) The solenoid drive circuit, motor relay drive circuit, valve relay drive circuit and ABS warning lamp drive circuit are the electrical conversion section that control the brake fluid by turning the hydraulic unit solenoid valve ON and OFF, turn the motor ON and OFF to produce a high-pressure fluid pressure at the hydraulic unit, and illuminate the warning lamp to alert of system failures.
- (5) The failure code memory is a memory used to save the abnormal states that occur in the system.

## BRAKE FLUID PRESSURE CONTROL

## &lt;ABS Control Cycle&gt;

- (1) In response to the signals from the wheel speed sensors for the four wheels, the ABS-ECU calculates the respective wheel speeds and wheel decelerating speeds to estimate the vehicle speed at the moment.
- (2) If the brake pedal is depressed, the fluid pressure applied to the wheel cylinders increases and the wheel speed decreases. If the difference between the wheel and vehicle speeds increases to the extent that the wheel decelerating condition exceeds a pre-determined value (point A), the ABS-ECU determines that the wheels are in the direction that they are locked and outputs a "reduce the pressure" signal to the solenoid valves to reduce the brake fluid pressure. (Between a and b)
- (3) As a result, the wheel decelerating speed begins to recover. When the wheel speed reaches point B, the "increase the pressure" and "reduce the pressure" signals are repeatedly output to adjust the brake fluid pressure and monitor the state. (Between b and c)
- (4) If the wheel decelerating speed continues to go back further beyond point C, the ABS-ECU determines that the danger of locking has been averted and outputs an "increase the pressure" signal again to increase the brake fluid pressure.
- (5) If the wheel decelerating condition exceeds the pre-determined value again, the brake fluid pressure is controlled by repeating the cycle of operations from steps (2) through (4).

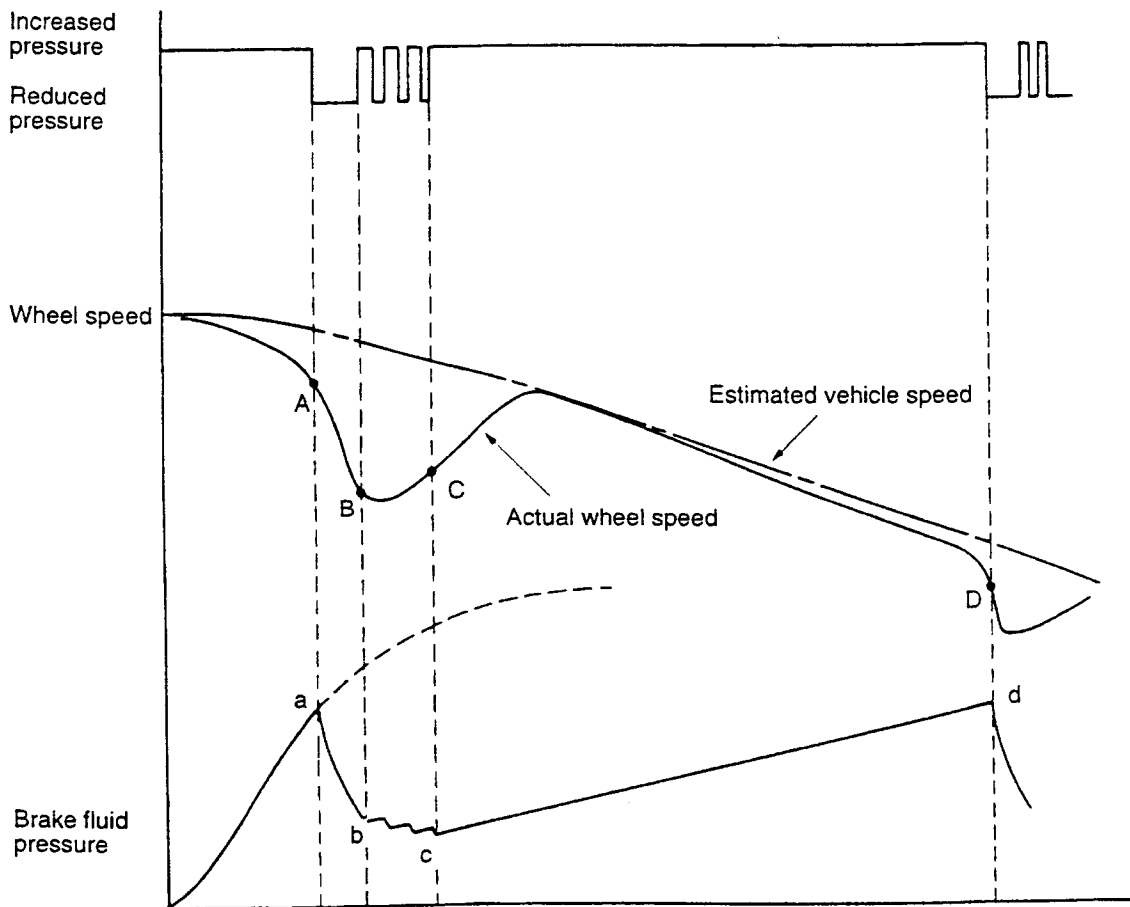

## NOTE

A change in brake fluid pressure causes a somewhat delayed change in wheel speed, because the inertia force acts on the wheel.

A14S0054

## &lt;Controlling the Four Wheels&gt;

Left/right independent control is adopted for the front wheels, and a unified control (select low control) 4-sensor 4-channel system is adopted for the rear wheels. (Refer to P.3-18.)

## &lt;Controlling Vehicle Speed&gt;

The ABS is operational when the vehicle speed is 6 km/h or more. The control ends when the vehicle speed drops to approx. 3 km/h. However, when the stop lamp switch has failed, the ABS is operational at a vehicle speed of approx. 13 km/h or more.

**INITIAL CHECK FUNCTION**

The ABS-ECU always performs an initial check on the ABS system by the diagnosis function. If it detects an error, the ABS system will be disabled and the warning lamp will be illuminated.

**Initial Check Operation**

- (1) When the ignition key is placed in the ON position, the power is supplied to the ABS-ECU, and the ABS-ECU starts a self-diagnosis sequence. During the self-diagnosis period, the valve relay stays in the "OFF" state and the warning lamp continues to be illuminated.
- (2) Next, the ABS-ECU drives the valve relay "ON" → "OFF" → "ON", and performs self-diagnosis of the valve relay. After the second "ON", conductivity is turned on for very short time to all solenoids, and the self-diagnosis of the solenoid and solenoid drive circuit is performed.

- (3) As with the diagnosis in step (2), self-diagnosis of the wheel speed sensor is performed with the wheel speed sensor disconnection monitor circuit in the ABS-ECU.
- (4) When the ignition key is placed in the "START" position, the engine will start, and the ABS-ECU power supply will turn off. However, as the valve relay turns "OFF", the warning lamp will continue to be illuminated.
- (5) If the engine starts and the ignition key is returned to the "ON" position, the ABS-ECU power supply is resumed, and initial checks in (1) through (3) are performed again.
- (6) When the initial check is completed correctly, the warning lamp goes out. If the stop lamp switch is OFF, power is supplied to all solenoids for a very short time to simultaneously turn the motor ON and check the hydraulic unit.

**NOTE**

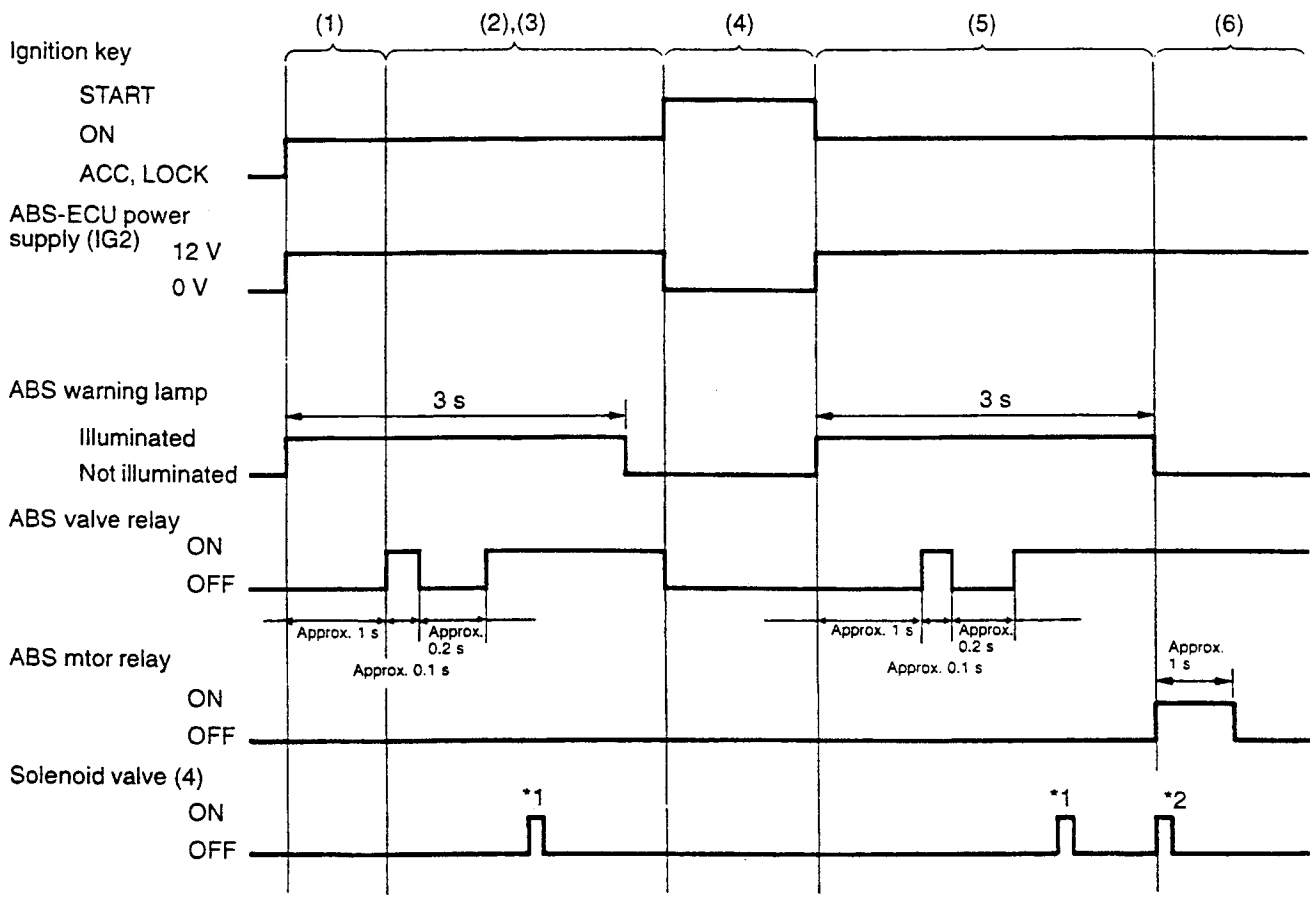

\*1: Solenoid check  
\*2: Hydraulic unit check

**ABS VALVE RELAY CONTROL**

- (1) The ABS valve relay turns ON in the normal state after the ignition switch has been set to the "ON" position or after the initial check when the engine has started. The power is supplied to the ABS valve relay to prepare for ABS operation. (Refer to P.3-23.)
- (2) If a system failure is observed, the ABS valve relay turns OFF, the system is isolated, and the ABS warning lamp illuminates.

**ABS MOTOR RELAY CONTROL**

Control starts after the initial check is completed normally. The motor is driven during the check and during the anti-lock control.

**SELF DIAGNOSIS OF WHEEL SPEED SENSOR SYSTEM**

The self-diagnosis of the wheel speed sensor system monitors for failure of each wheel speed sensor system (speed sensor, ABS rotor, etc.) with the self-diagnosis program incorporated in the computer. At the same time, faults such as disconnection or short circuit of the sensor are monitored by the disconnection monitor circuit in the ABS-ECU. The former method is called software fault detection, and the latter is called hardware fault detection.

**(1) Software Fault Detection**

The wheel speeds of the four wheels operated from the sensor output are compared. The sensor system of the wheel with an abnormal speed or abnormal deceleration speed is judged as faulty.

**FAIL-SAFE FUNCTION**

Should a failure occur in the ABS system, the ABS-ECU isolates the system to retain the vehicle's ordinary braking function, thus assuring a high measure of safety.

- If the ABS-ECU determines that the system

**DIAGNOSIS FUNCTIONS**

To facilitate inspection of the ABS system, the ABS-ECU offers the following facilities:

- Diagnosis code output
- Service data output
- Actuator test

**PROCEDURE FOR ENTRY OF DATA INTO THE DIAGNOSIS FUNCTION WHEN THE MUT-II IS USED, AND SUBSEQUENT CONTROLS**

By connecting the MUT-II to the diagnosis connector while the vehicle is stopped, the MUT-II can be used. When fixed to the 4ABS through communication with the MUT-II, the MUT-II mode is entered.

**NOTE**

- (1) The MUT-II is connected while the ignition switch is set to the "OFF" position. The MUT-II

Thus, faults can be detected when the vehicle starts travelling or during travel.

**(2) Hardware Fault Detection**

Disconnection and short circuits in the sensor or harness, etc., are monitored by the electronic circuit assembled in the ABS-ECU and the voltage monitor program. A feature of this disconnection and short circuit monitor circuit is that disconnection and short circuit faults can be constantly detected (even when stopped).

Note that when travelling, depending on the vehicle state and fault state, the fault may be detected with the software fault detection before the disconnection or short circuit fault is detected.

malfunctions as the result of self-diagnosis, it illuminates the ABS warning lamp, drives the valve relay to interrupt control of the solenoid valves in the hydraulic unit, and restores the ordinary braking mode.

All of the items described above can be checked by the MUT-II.

Note that diagnosis codes can also be inspected by the flickering of the ABS warning lamp.

mode will not be entered if the MUT-II is connected while the ignition switch is set to the ON position (system ON).

- (2) In the MUT-II mode, the ABS warning lamp will be illuminated and anti-lock control will be prohibited. This is to prevent modes in which the brakes may be temporarily inhibited by the actuator test.

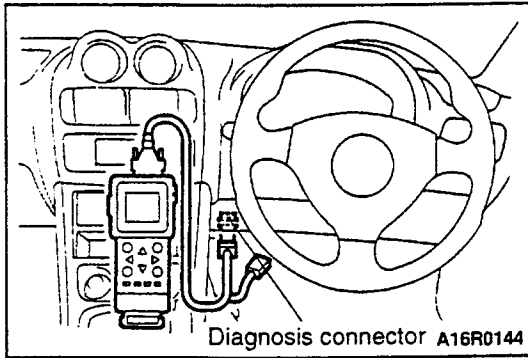

MUT-II mode entry condition	<ol style="list-style-type: none"> <li>1. The 4-wheel wheel speed is 0 km/h (stopped) and ignition switch is set to the OFF position.</li> <li>2. Connect the MUT-II check harness to the diagnosis connector on the vehicle, and set the ignition switch to the ON position.</li> <li>3. Select ABS with the MUT-II operation switch. (Receive the specified serial data)</li> </ol>
MUT-II mode	Prohibit the anti-lock control, and illuminate the ABS warning lamp.

**DIAGNOSIS CODES**

Conditions detected as a result of diagnosis are associated with a total of 23 codes and the codes are stored in the volatile memory. Even if the ignition key is placed in the "OFF" position, the contents of the memory are not cleared, as the memory remains powered by backup power supply. (The memory, however, is cleared if the battery terminals are disconnected.)

These codes are readable by connecting the MUT-II.

When the MUT-II is not used, they are also readable from the ABS warning lamp which is turned ON and OFF repeatedly in a pattern specific to each code.

**(1) Diagnosis Items**

Diagnosis code No.	Malfunction	
11	Open in front right wheel speed sensor circuit	
12	Open in front left wheel speed sensor circuit	
13	Open in rear right wheel speed sensor circuit	
14	Open in rear left wheel speed sensor circuit	
16	Abnormal ABS-ECU power supply voltage	
21	Short in front right wheel speed sensor circuit	
22	Short in front left wheel speed sensor circuit	
23	Short in rear right wheel speed sensor circuit	
24	Short in rear left wheel speed sensor circuit	
31	Front right wheel rotor No. of teeth malfunction	
32	Front left wheel rotor No. of teeth malfunction	
33	Rear right wheel rotor No. of teeth malfunction	
34	Rear left wheel rotor No. of teeth malfunction	
41	Front right wheel solenoid valve malfunction	The diagnosis codes are output when there is no response to the drive signals for respective solenoid valves.
42	Front left wheel solenoid valve malfunction	
43	Rear right wheel solenoid valve malfunction	
44	Rear left wheel solenoid valve malfunction	
51	ABS valve relay OFF state detection malfunction (ON fault)	
52	ABS valve relay ON status detection malfunction (OFF fault)	
53	ABS motor relay, motor drive malfunction (OFF fault)	
54	ABS motor relay, motor stop malfunction (ON fault)	
55	Motor rotation malfunction	
63	ABS-ECU internal failure	

**(2) Indication of Diagnosis Code by Warning Lamp**

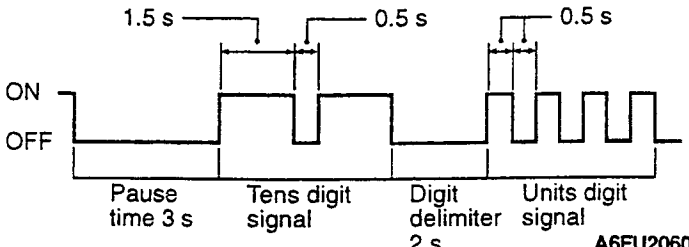
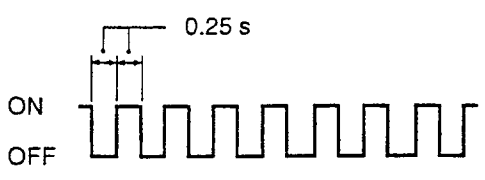
Example of ON-OFF indication to be presented when diagnosis code No.24 is output	ON-OFF indication in normal condition
	

**NOTE**

When a fault occurs, the valve relay is forced to OFF, and the warning lamp continues to light during the period the fault persists. For this reason, the valve relay must be removed when the diagnosis code is to be checked.

**(3) Erasing the Fault Code Memory****NOTE**

- (1) The fault code memory cannot be erased when the ABS-ECU is in the fail-safe state.
- (2) Check the diagnosis code again to check whether the memory has been erased.

- (3) After the memory is erased, the commands from the MUT-II cannot be accepted. To confirm the diagnosis code, stop and start the engine once, and then operate the MUT-II again.

**<When Using MUT-II>**

Follow the MUT-II messages to erase the memory. (Refer to the new manual or MUT-II Instruction Manual for details.)

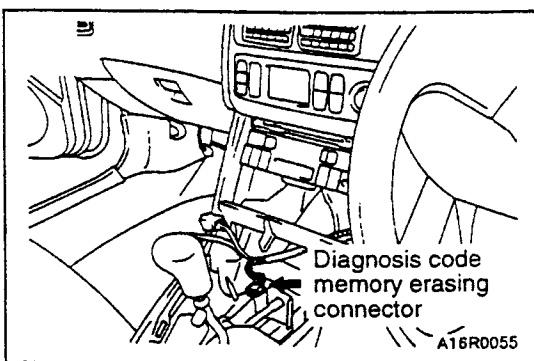
**<When Using warning lamps>**

- (1) Set the ignition key to the "ON" position while the diagnosis code memory erasing connector (2-pin connector shown on left) is connected across the two terminals.
- (2) Set the ignition key to the "OFF" position after approx. 7 seconds have passed.
- (3) Release the connection of the two diagnosis code memory erasing connector terminals, and set the ignition key to the "ON" position again. Erasing of the fault codes will be completed at this point.



**SERVICE DATA OUTPUT**

Of the ABS-ECU input data, the following items can be read by the MUT-II.

**(1) When System is Normal**

Code No.	Items	Displayed unit
11	Front right wheel speed	km/H
12	Front left wheel speed	km/H
13	Rear right wheel speed	km/H
14	Rear left wheel speed	km/H
16	ABS-ECU power supply voltage	HIGH/LOW
36	Stop lamp switch ON/OFF state	ON/OFF

**(2) When System is Cutoff by ABS-ECU**

When the ABS-ECU functions are stopped due to the diagnosis function, the wheel speeds given

in Nos. 11 to 14 above will not be displayed. The data displayed on the MUT-II will constantly be "0.0 km/h".

**ACTUATOR TEST**

Forced drive of the following actuators can be accomplished by use of the MUT-II. By using this function, the hydraulic unit functions can be checked.

**NOTE**  
When the ABS-ECU is out of service, no actuator test can be executed.

**Actuator Test Specifications**

No.	Drive condition		Drive specifications
01	A and B	Solenoid valve for front right wheel	Carries out pressure increase → pressure decrease (2 sec.) → pressure increase. (Motor turns ON simultaneously with the pressure decrease, and turns OFF 0.93 sec. after pressure decrease is completed.)
02		Solenoid valve for front left wheel	
03		Solenoid valve for rear right wheel	
04		Solenoid valve for rear left wheel	
05	A	ABS valve relay	The relay OFF signal is output for 2 sec. The ABS-ECU outputs the ABS warning lamp off signal for six seconds (including two seconds before and after the relay OFF signal output). As a result, the operation is confirmed by the ABS warning lamp illumination when the relay is OFF.
06	A	ABS motor relay	The motor ON signal is output for 2 sec.

Drive condition  
 (1) Condition A: max. wheel speed is less than 10 km/h.  
 (2) Condition B: wheel speed of both front wheels or both rear wheels is 0 km/h.

## PARKING BRAKES

- The parking brake is a mechanical type acting on the rear wheels (for all models). Disc brakes are mounted.
- The parking brakes are operated by a lever. The offset positioning of the lever toward the driver's seat side facilitates operation of the parking brake.

### CONSTRUCTION DIAGRAM

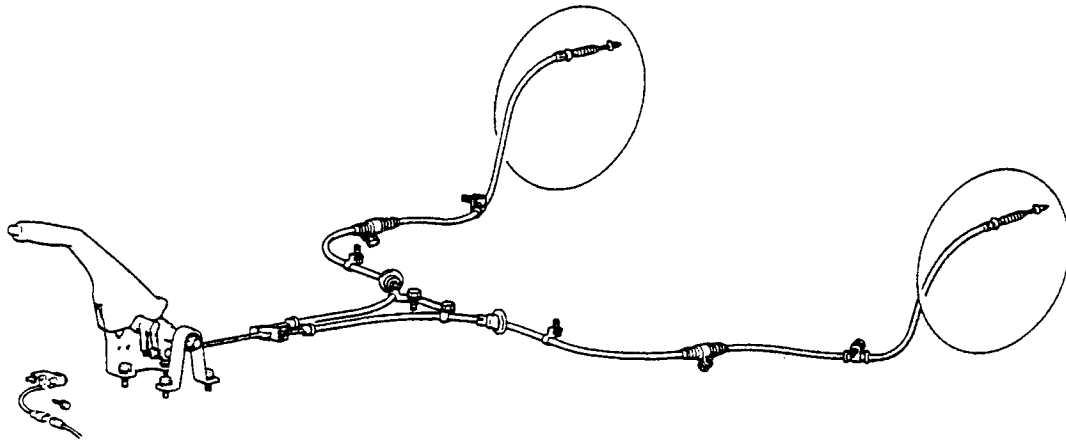

14R0021

---

# BODY

## CONTENTS

<b>GENERAL DESCRIPTION</b> .....	<b>2</b>	Power Window .....	6
Features .....	2	Multiplex Communication System .....	8
<b>MAIN BODY</b> .....	<b>3</b>	<b>WINDOW GLASS</b> .....	<b>10</b>
Body Paneling .....	3	<b>ELECTRIC SUNROOF</b> .....	<b>11</b>
Body Colour Charts .....	3	Construction Diagram .....	11
<b>DOORS</b> .....	<b>4</b>	Construction and Operation .....	12
Door Lock .....	4	Sunroof-ECU .....	12
Keyless Entry System .....	5		

---

## GENERAL DESCRIPTION

### FEATURES

Light weight, added rigidity

1. Extensive use of high tension steel panels
2. Effective use of reinforcement
3. Increased panel thickness for outer panel and roof panel
4. Increased cross section for side sill and upper frame

Corrosion control

- Extensive use of anti-corrosion steel panels

Improved controllability and safety

1. Side door beam to enhance occupant's safety in side collision
2. Adoption of the central door locking system
3. Adoption of radio wave keyless entry system
4. Adoption of power window switch and lock switch with one-touch mechanism
5. Adoption of safety mechanism to prevent catching when power window glass rises

Improved appearance

1. Flush body surface
2. Adoption of outer slide type motor-driven sunroof with tilt-up mechanism that can be operated with one touch (option)

# MAIN BODY

## BODY PANELING

The body features a monocoque construction which has already established reputation in service. Ample use of high-tensile steel panels and

anticorrosion steel panels not only reduces the body weight but ensured good corrosion control.

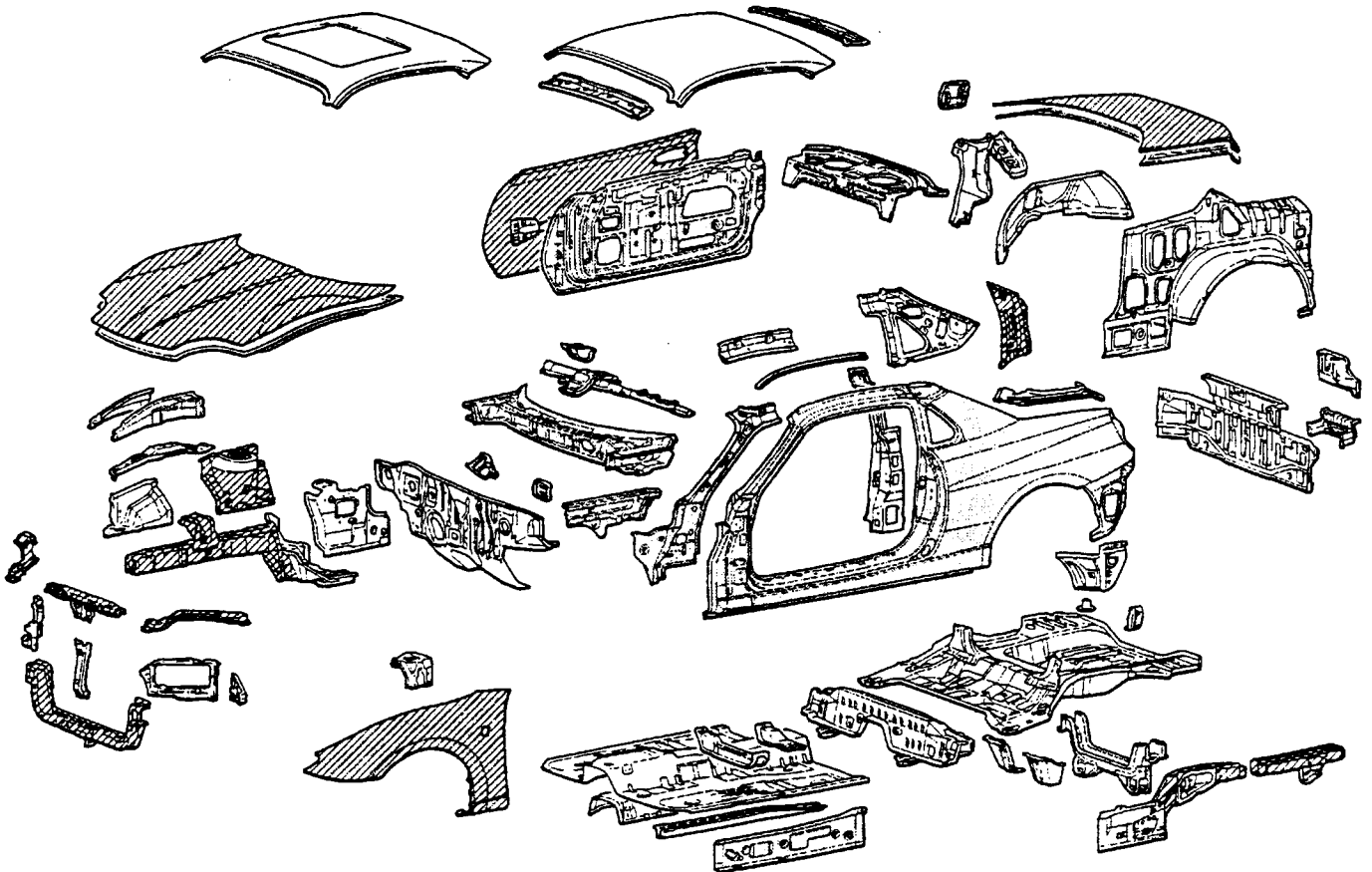

31R0069

- : High-tensile steel panels
- : Anticorrosion steel panels

## BODY COLOUR CHARTS

Paint used by manufacturer	Colour	Body colour code	Colour number	Body colour name	Composition of film	Engine compartment and luggage compartment colour	
						Colour Number	Colour
	SILVER	A26	AC11126	Symphonic Silver	Metallic	AC11235	LIGHT GRAY
	DARK BLUE	T73	AC11173	Ijssel Blue	Interference Pearl	AC11194	DARK BLUE
	DARK GREEN	G13	AC11213	Timber Green	Interference Pearl	AC11255	GREEN
	BLACK	X08	AC11008	Pyreness Black	Coloured Pearl	AC10903	BLACK
	WHITE	W83	AC10983	Scotia White	Solid	AC10863	WHITE
	RED	R71	AC11071	Passion Red	Solid	AC10795	RED

# DOORS

## DOOR LOCK

(1) The central door locking system has been used for some models. This enables all doors to be locked or unlocked using the door key or the inside lock knob (both on driver's side).

(2) The radio wave type keyless entry system has been adopted. (Refer to P.4-5.)

### CONSTRUCTION DIAGRAM

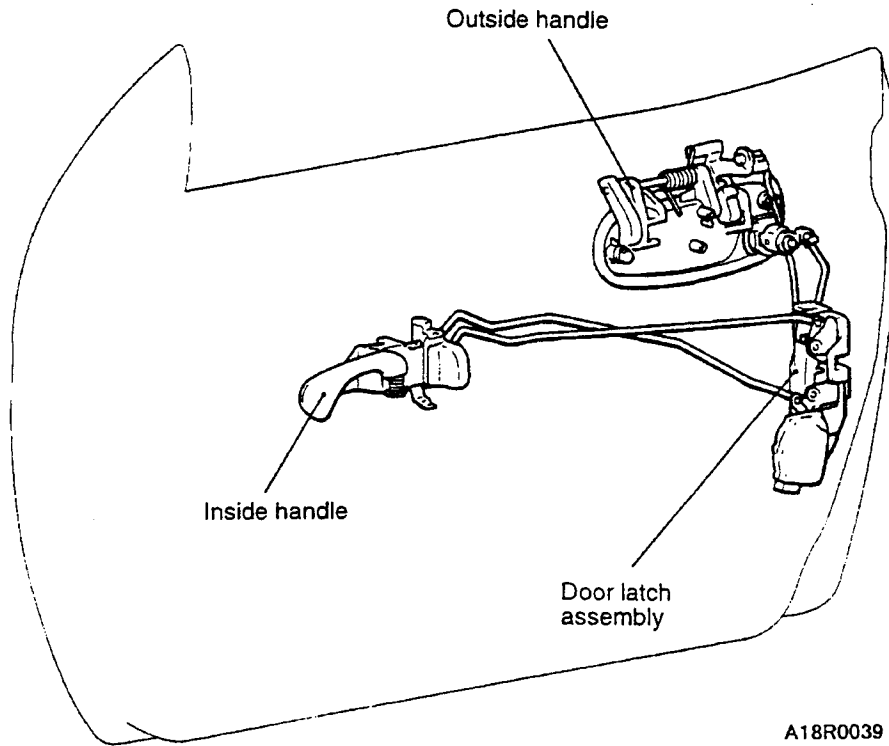

A18R0039

### KEYLESS ENTRY SYSTEM

The radio wave type keyless entry system has been used. This allows all doors to be locked or unlocked

with remote control within a range approx. 1 m from the vehicle.

### CONSTRUCTION DIAGRAM ANTENNA AND RECEIVER

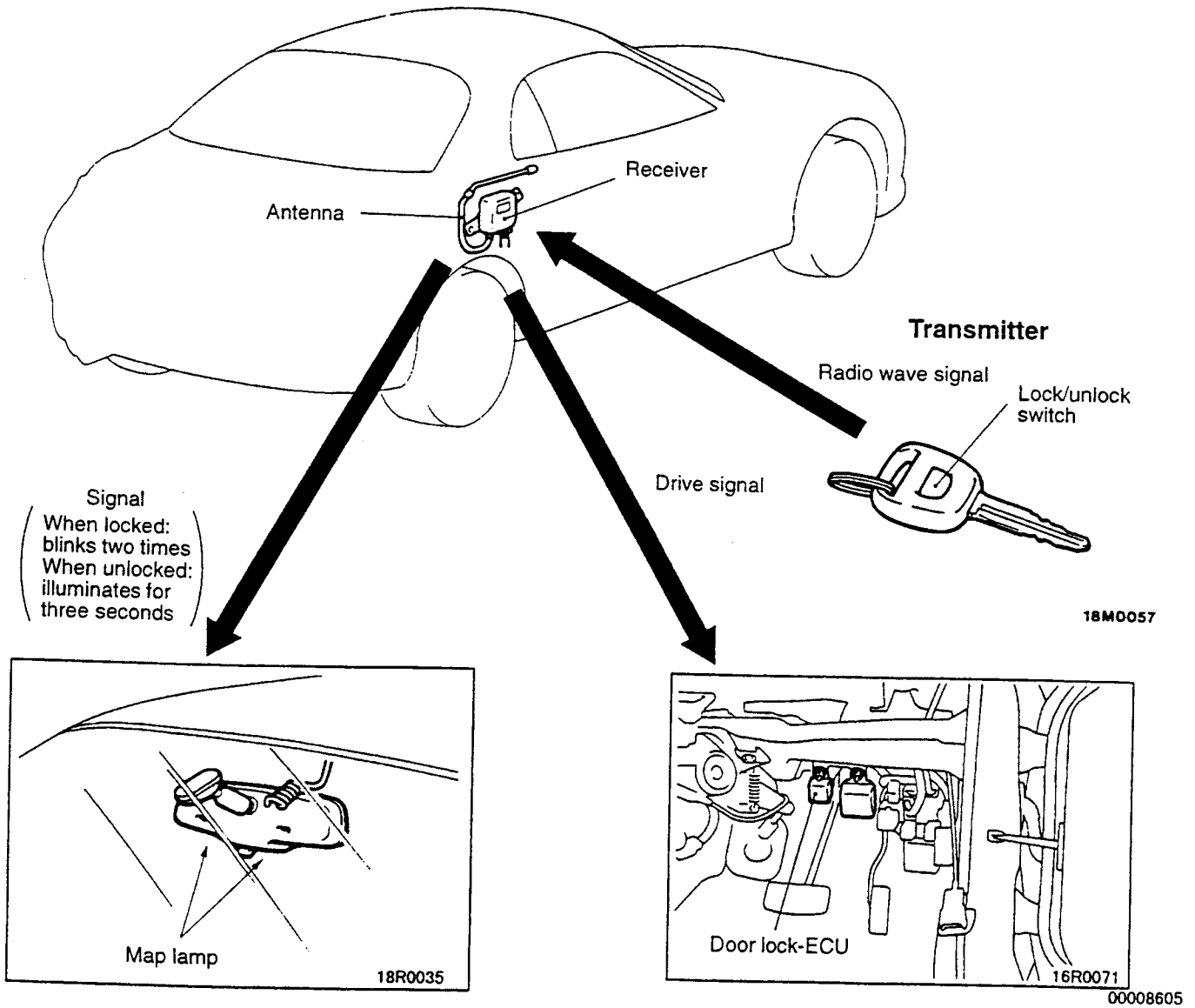

## POWER WINDOW

- (1) A safety mechanism has been incorporated to improve safety. This mechanism lowers the door window glass by approx. 110 mm when catching of a hand or neck, etc., is detected while raising the door window glass. In addition, a limit switch has been installed on the window regulator.
- (2) The power window switch incorporates a mechanism to press the switch knob to lower the door window glass and pull the switch when raising the window.
- (3) A one-touch mechanism has been incorporated for the main switch. This allows the door window switch to be fully opened or closed with one-touch. Furthermore, a lock switch to stop the opening and closing of the passenger side window has also been incorporated.
- (4) A multiplex transmission system has been incorporated in the power window to convey the main switch signals. A circuit has been configured to allow the power window on the passenger side to be operated with the corresponding door switch, even if the multiplex transmission system malfunctions.

### NOTE

Refer to P.4-8 for details on the multiplex communication system.

## CONSTRUCTION DIAGRAM

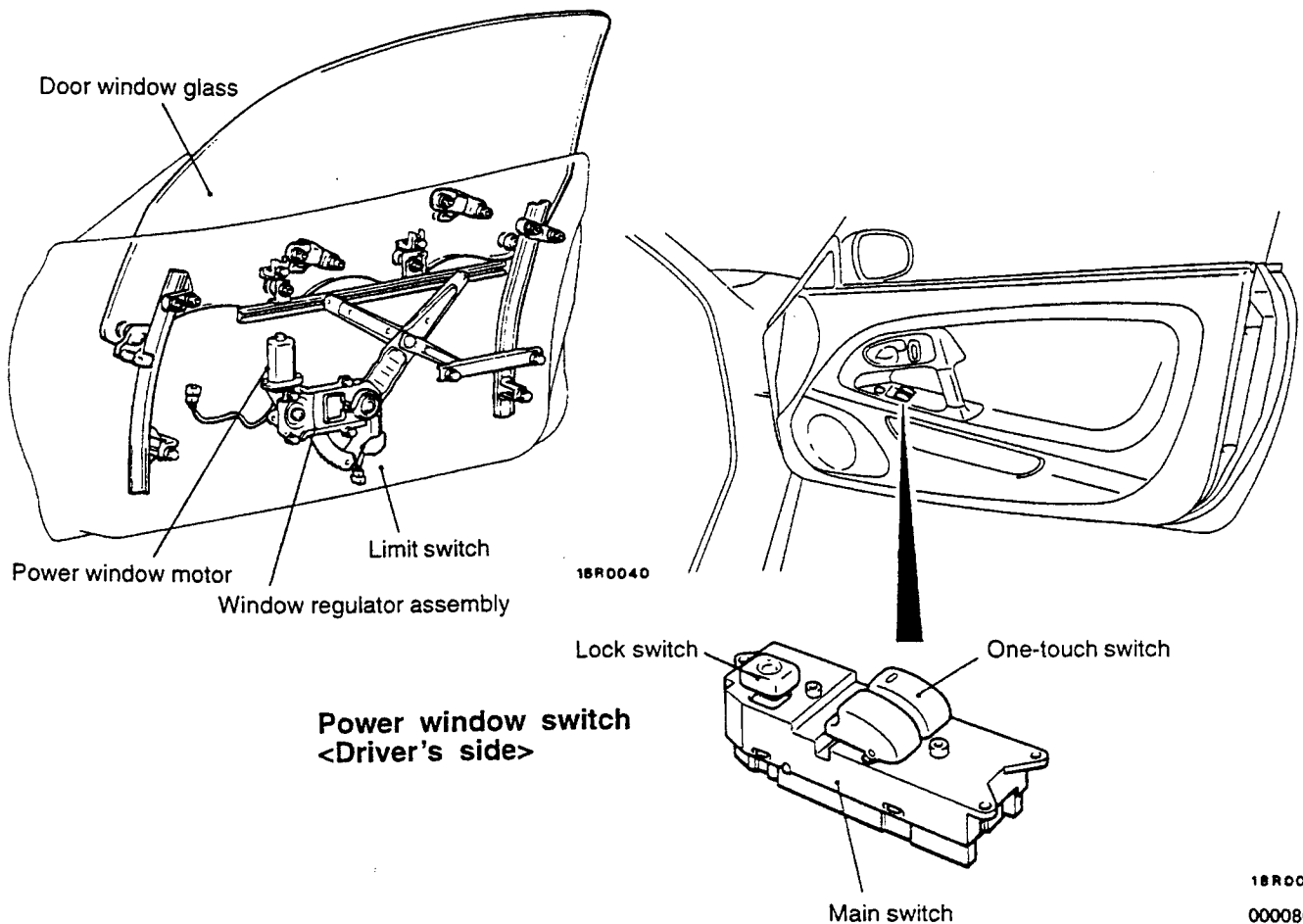

1BR0045

00008606



BLOCK DIAGRAM

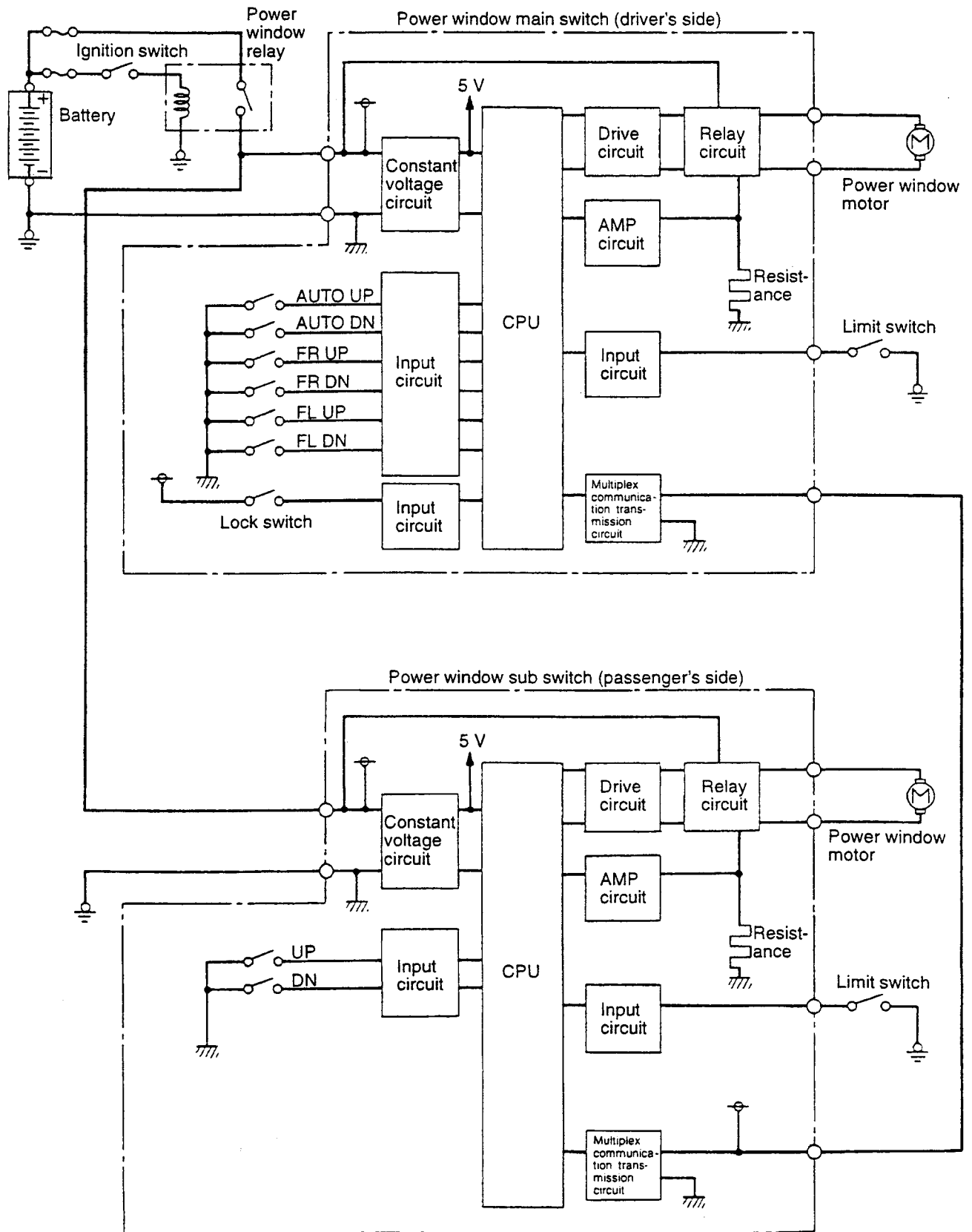

## MULTIPLEX COMMUNICATION SYSTEM

The multiplex communication system is a wire saving system which has been developed for reducing the harness weight and complexity that would otherwise be increased by addition of electric devices. This system allows the power window to be opened and closed by communication over one

signal wire between the driver's power window main switch and passenger's power window sub switch. The circuit has been designed so that even if an open circuit occurs in the signal line, the power window opening and closing operations will not be affected.

### CONSTRUCTION DIAGRAM

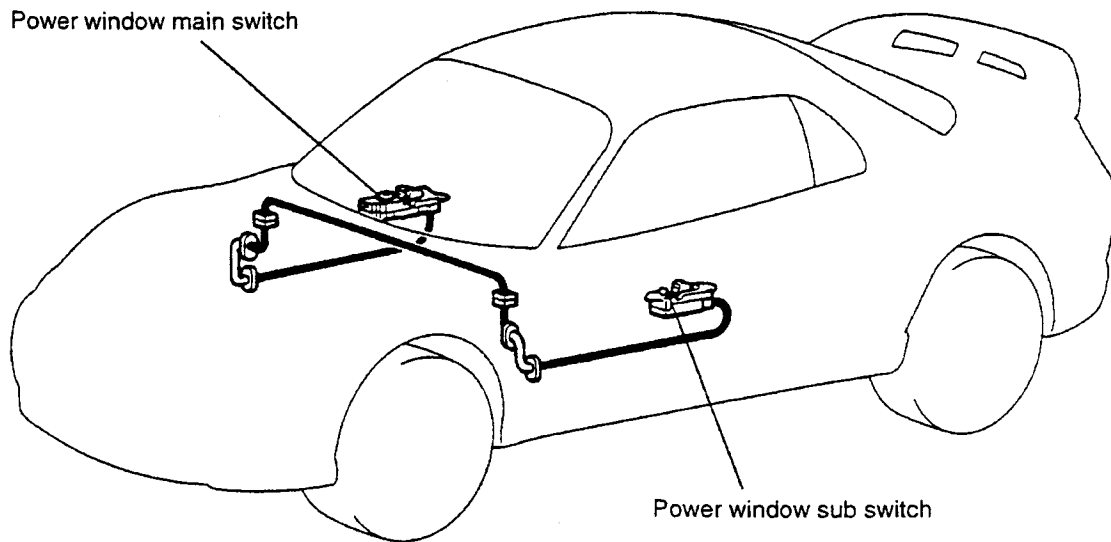

A18R0044

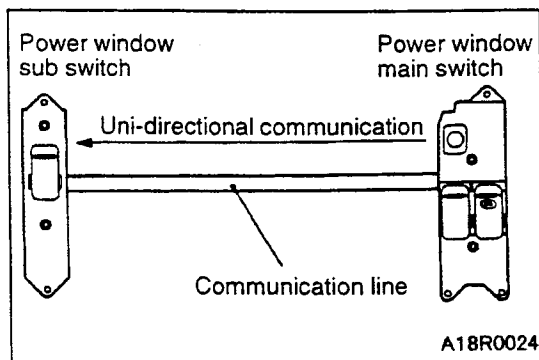

A18R0024

### COMMUNICATION METHOD

A signal line dedicated for transmission of multiplex communication data is connected between the power window main switch and the power window sub switch.

Communication is uni-directional. The power window main switch has a transmitting circuit only, whereas the power window sub switch has a receiving circuit only. The communication method is by asynchronous PWM (Pulse Width Modulation) transmission.

**COMMUNICATION DATA COMPOSITION**

The communication data is configured of an 8-bit data frame, marker that indicates the start and stop position, and a check bit (parity bit).

The following types of data is assigned to the 8-bit data frame to transmit the switch signals.

**<Data composition>**

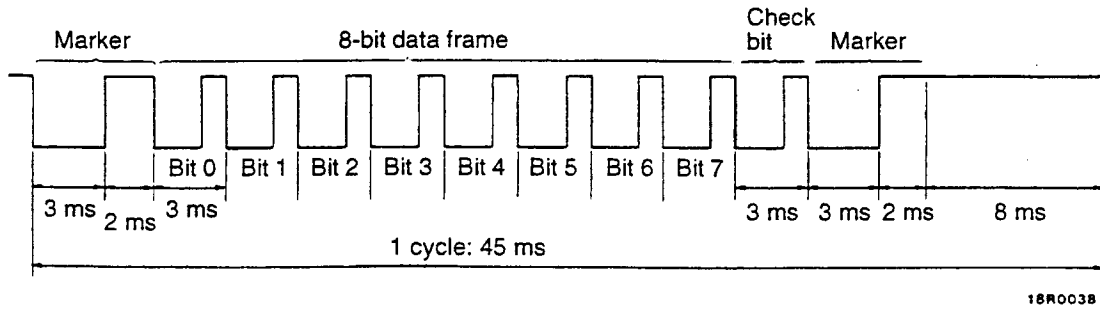

**<Data waveform>**

Data "0" signal when the switch is OFF.

Data "1" signal when the switch is ON.

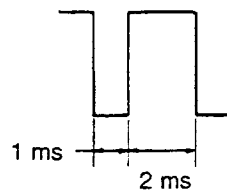

**Data Map**

Bit No.	Data name
0	Passenger's door power window UP switch signal
1	Passenger's door power window DOWN switch signal
2-6	-
7	Power window lock switch signal

**WINDOW GLASS**

Laminated glass is used for the windshield glass, and tempered glass is used for the other glass.

Name	Type	Thickness (mm)	Colour	Visible radiation transmittance (%)
Windshield	Laminated glass	4.7	Green	78.7
Door window glass	Tempered glass	4.0	Green	80.0
Quarter window glass	Tempered glass	3.5	Green	-
Rear window glass	Tempered glass	3.5	Green	
Roof lid glass	Tempered glass	4.0	Bronze	

**NOTE**

The value of visible radiation transmittance is a reference value. There may be some error due to inconsistencies.

## ELECTRIC SUNROOF

A motor-driven outer sliding type glass sunroof with tilt-up mechanism is available as an option for all models. Even with the roof lid glass fully closed, sufficient light and a sense of openness can be obtained by opening the sunshade. By tilting the roof lid glass up, sufficient ventilation can be provided.

The sunroof offers the following features.

- All of the sunroof slide open/close and tilt down operations can be performed by a single switch.
- If external force is applied while tilting up, causing the roof lid glass to be obstructed, the roof lid glass will continue to operate to the complete state and then stop.

- If external force is applied while sliding open, causing the roof lid glass to be obstructed, the roof lid glass will stop immediately.
- If external force is applied while sliding close or tilting down, causing the roof lid glass to be obstructed, the operation will revert.
- Even after the ignition switch has been set to OFF, the sunroof can be operated for a period of 30 seconds. If the door is opened during this time, the sunroof can be operated for another 30 seconds from his time.

## CONSTRUCTION DIAGRAM

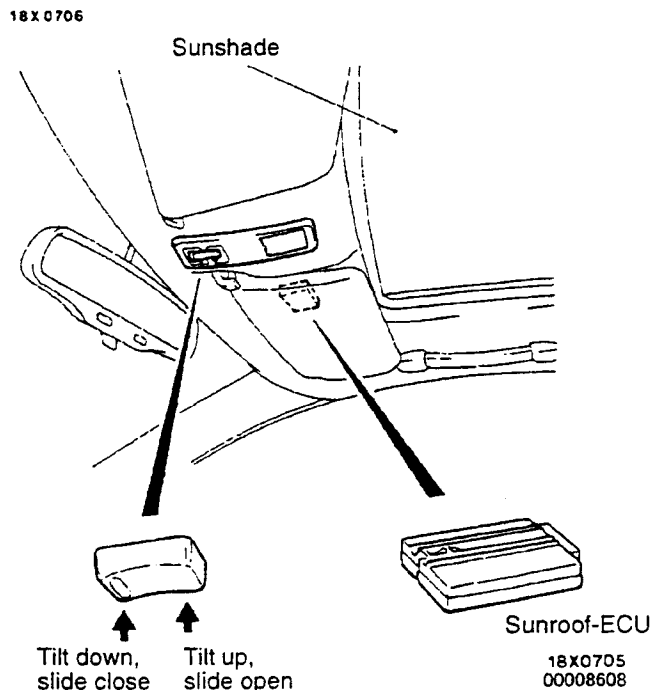
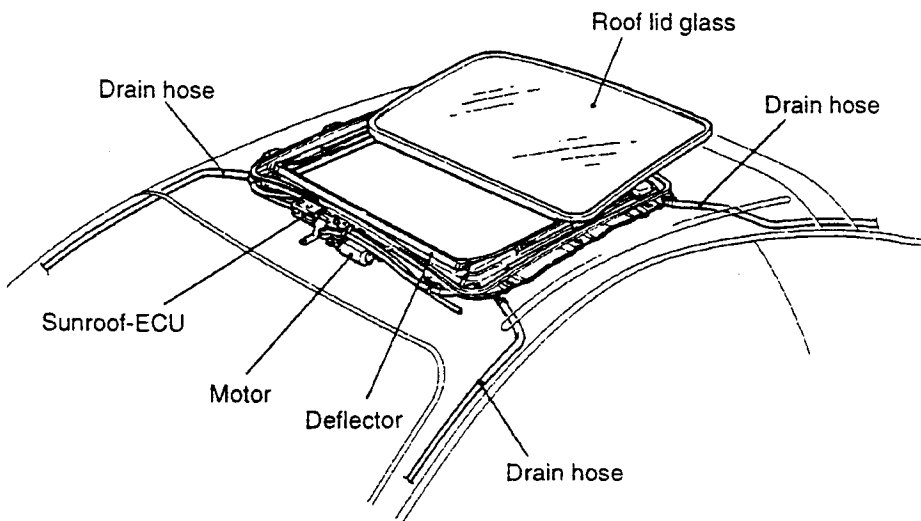

**CONSTRUCTION AND OPERATION**

**Sunroof-ECU**

The sunroof-ECU has a built-in microprocessor which controls operation of the motor in proper

ways suitable for different states, depending on the sunroof switch signals and door switch signals.

**SYSTEM DIAGRAM**

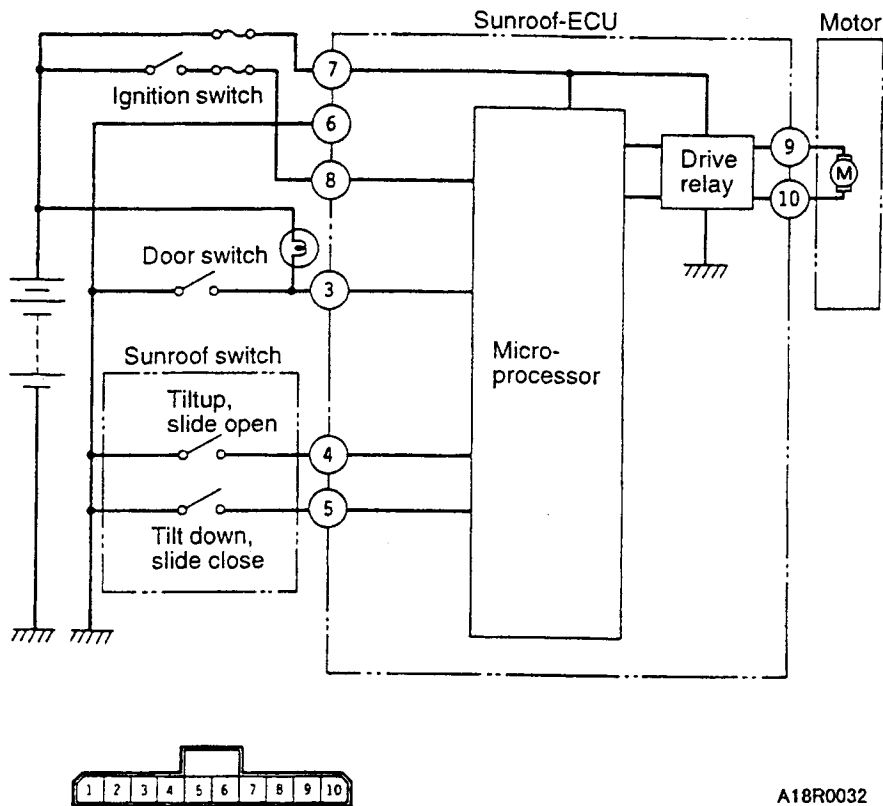

A18R0032

**TILT-UP OPERATION**

(1) When the sunroof switch (tilt up) is pressed for more than 0.2 second, the motor starts running.

(2) When the movement of the roof lid glass is blocked while tilting up, the motor continues to operate until the roof lid glass completes the tilt-up, and then stops.

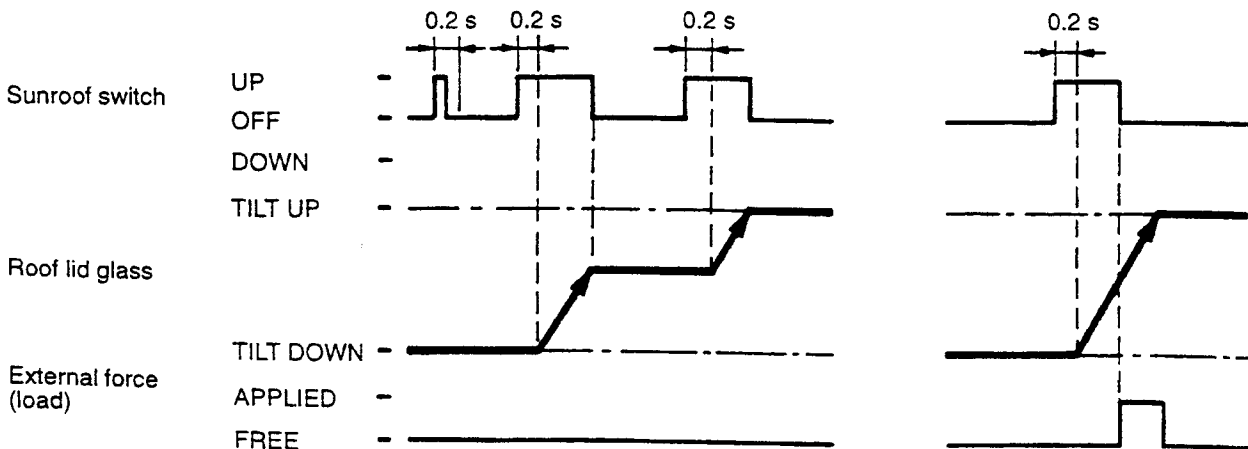

A18X0645

**TILT-DOWN OPERATION**

- (1) When the sunroof switch (tilt down) is pressed for more than 0.2 second, the motor starts running.
- (2) When the movement of the roof lid glass is blocked while tilting down, the motor rotates

in reverse and continue to return the roof lid glass to the full up position, and then stops.

**NOTE**

Full up: Position where roof lid glass starts sliding open.

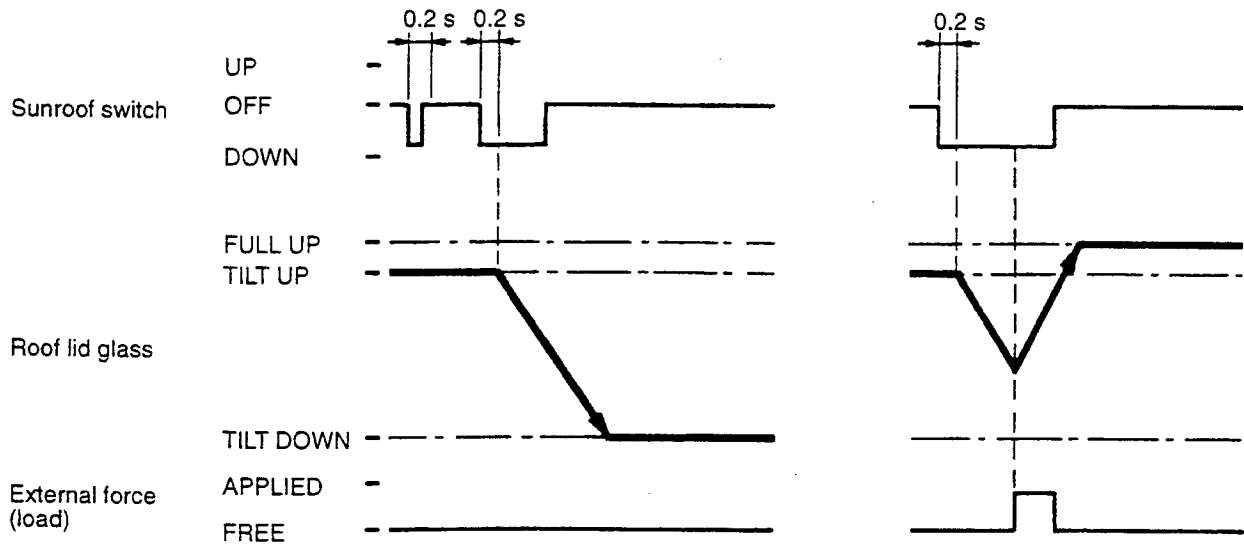

A18R0029

**SLIDING OPEN OPERATION**

- (1) When the sunroof switch (slide open) is pressed for more than 0.2 second, the motor starts running.
- (2) When the movement of the roof lid glass is blocked intermediately during a sliding open operation, the motor immediately stops.

- (3) When the sunroof switch is pressed to the slide close side during a slide open operation, the motor stops.
- (4) If the switch is held down to the slide close side, the motor rotates in reverse to rotate in the slide close direction.

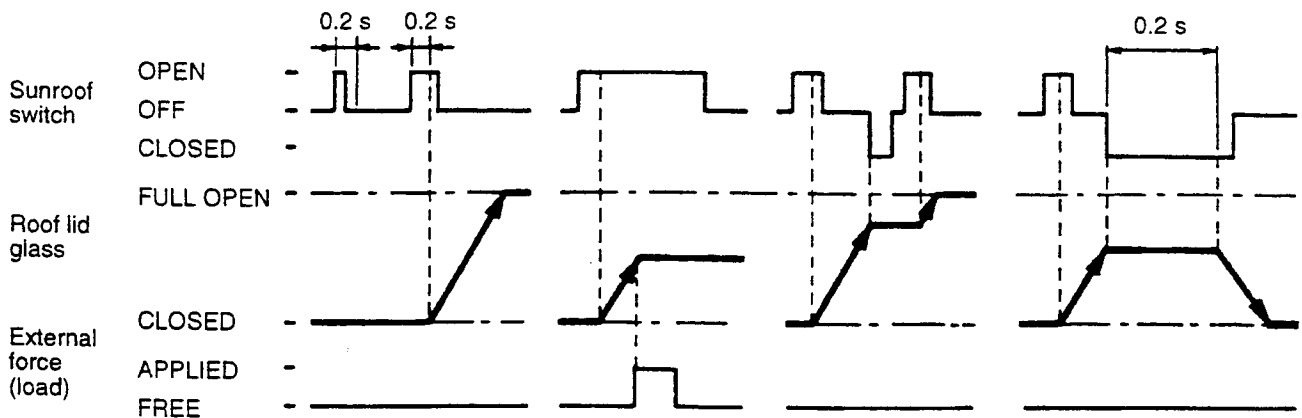

A18X0600

**SLIDING CLOSED OPERATION**

- (1) When the sunroof switch (slide close) is pressed for more than 0.2 second, the motor starts running.
- (2) When the movement of the roof lid glass is obstructed during the sliding close operation, the motor rotates in reverse to return the roof lid glass approx. 60 mm in the slide open direction, and then stops.

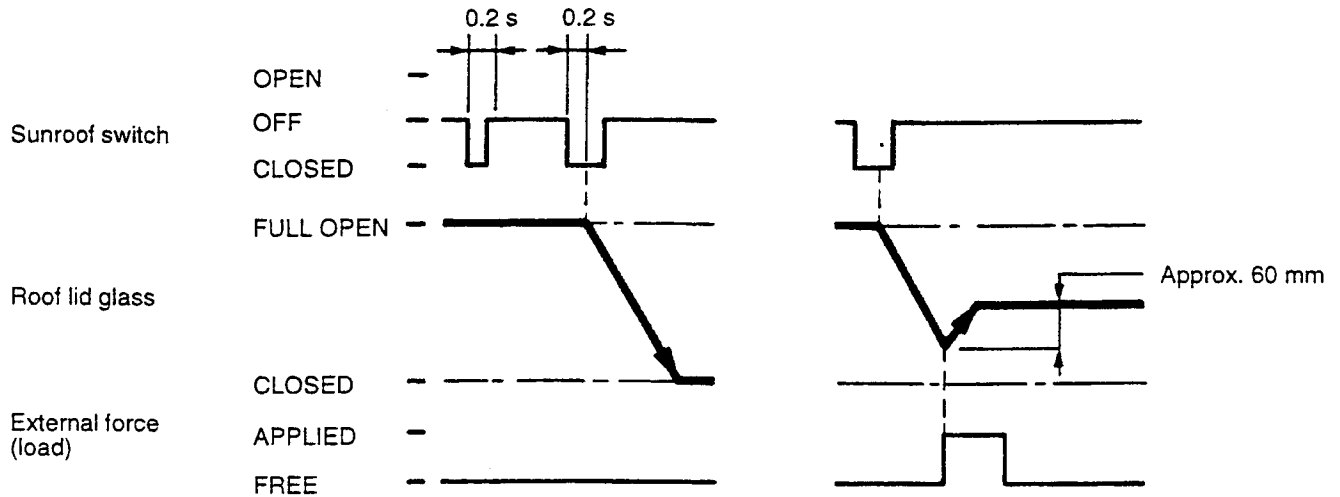

A18X0647

**KEY OFF FUNCTION**

- (1) The sunroof can be operated for 30 seconds after the ignition switch has been set to OFF. If 30 seconds pass during the slide close operation, the sunroof will operate until it is fully closed.

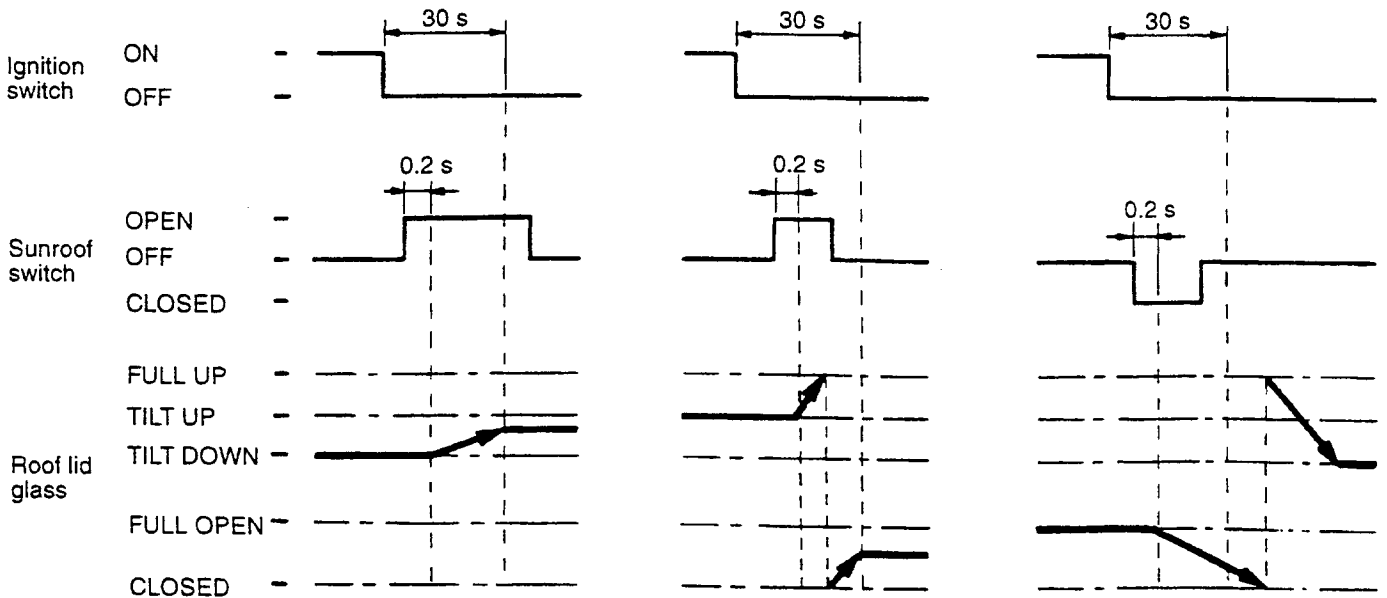

A18R0030



(2) If the drivers' side door is opened within 30 seconds after setting the ignition switch to OFF, the sunroof can be operated for 30 seconds

from that point. If this time is passed while sliding close, the sunroof will operate until it is fully closed.

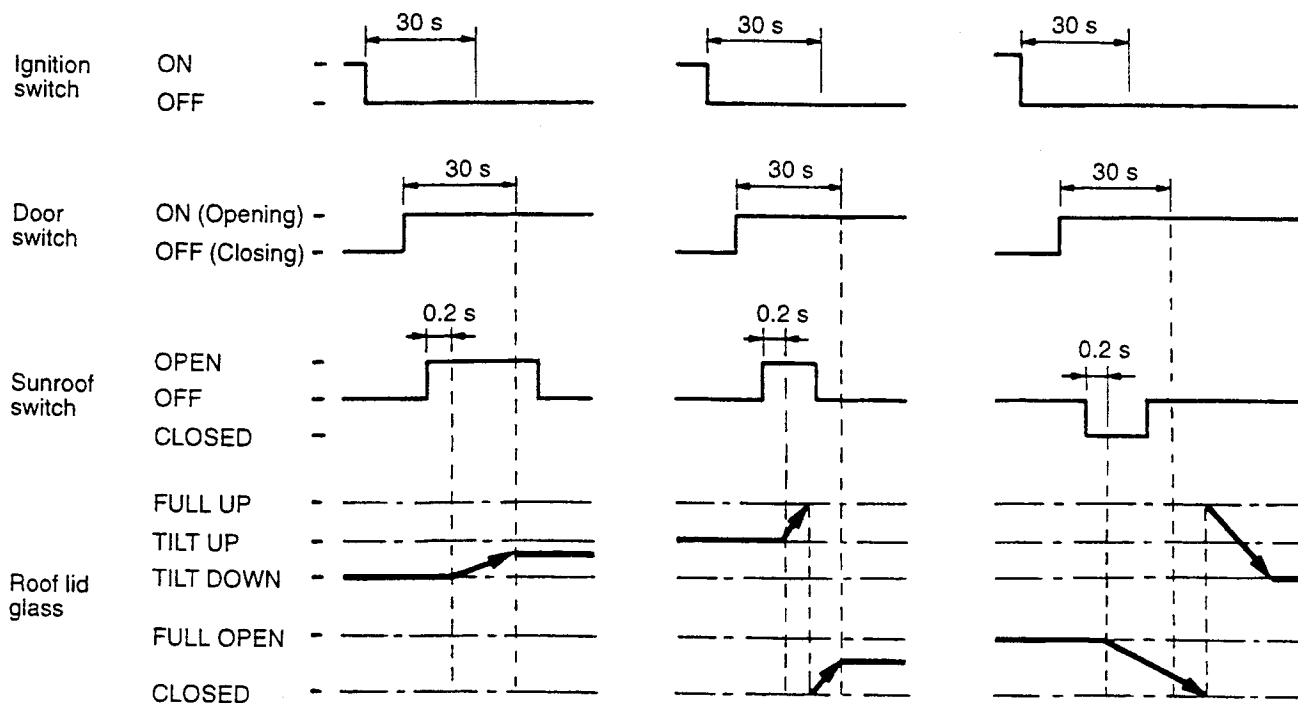

A18R0031

(3) Once the sunroof has been slid close to the fully closed state, the sunroof cannot be

operated even if within 30 seconds after setting the ignition switch to OFF.

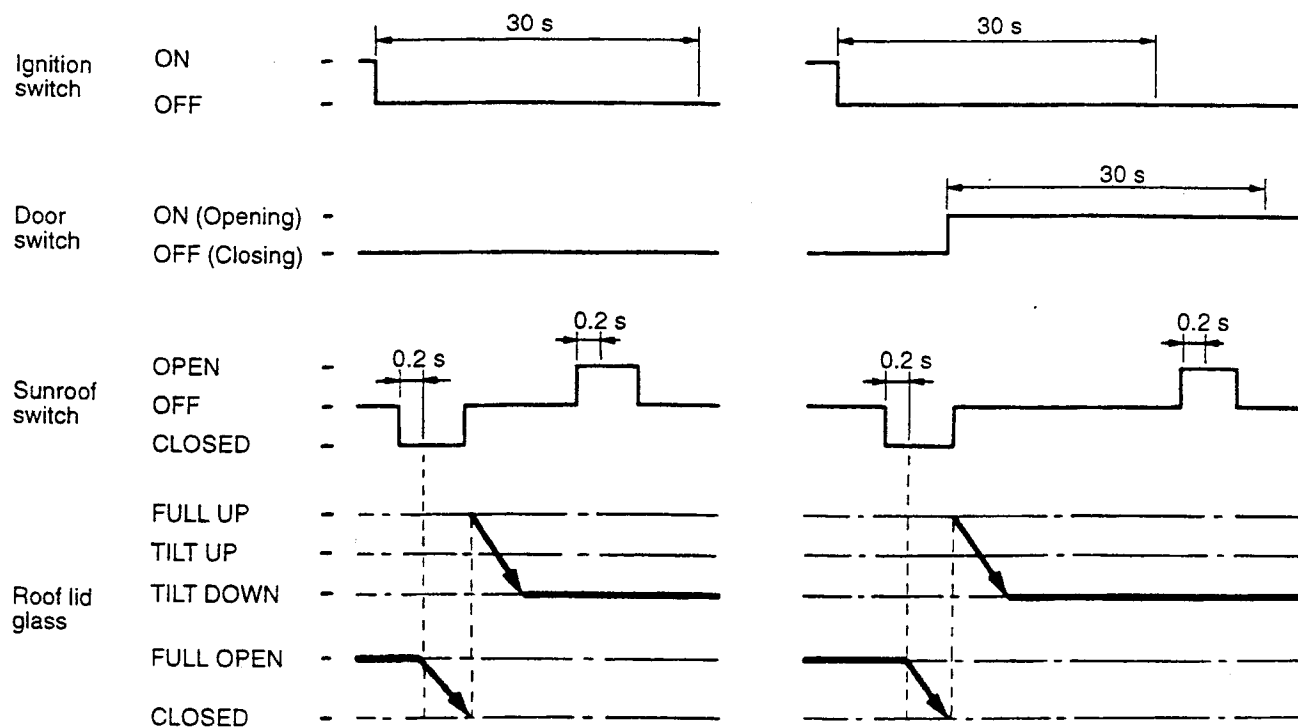

A18X0802

---

# EXTERIOR

## CONTENTS

GENERAL DESCRIPTION .....	2	AERO PARTS .....	3
Features .....	2	OUTSIDE MIRROR .....	4
BUMPER .....	3		

---

## GENERAL DESCRIPTION

For both the front and rear of the vehicle, large-size resin bumpers have been adopted for marketability.

In addition, aero parts have been mounted to improve the aerodynamic characteristics.

### FEATURES

- |   |   |
|---|---|
| Improvement of appearance                     | — Large-size resin bumpers  |
| Enhancement of aerodynamic characteristic     | — 1. Rounded bumper corners<br>2. Aero parts adopted <ul style="list-style-type: none"><li>● Side airdam</li><li>● Rear spoiler</li></ul> |
| Improvement of accessories for easy operation | — Motor driven storage type remote controlled door mirror adopted   |
| Resources recycling oriented measures         | — Material symbol has been stamped on the resin parts, and easy-to-recycle materials employed wherever possible.                          |

## BUMPER

A large PP (polypropylene) bumper face integrated with the body has been mounted, to give a feeling of width and strength. The following features have also been added.

- The front and rear bumper corners have been rounded creating a flush surface with the body, and thereby improving the aerodynamics feature.

- Thermoplastic modified PP, effectively recycled, has been used for the bumper material to effectively use resources.

### CONSTRUCTION DIAGRAM

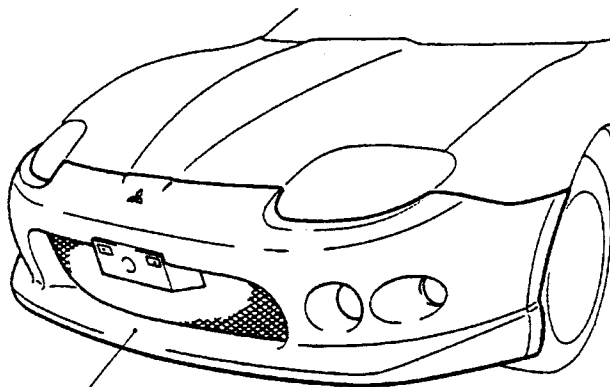

Front bumper

18R0122

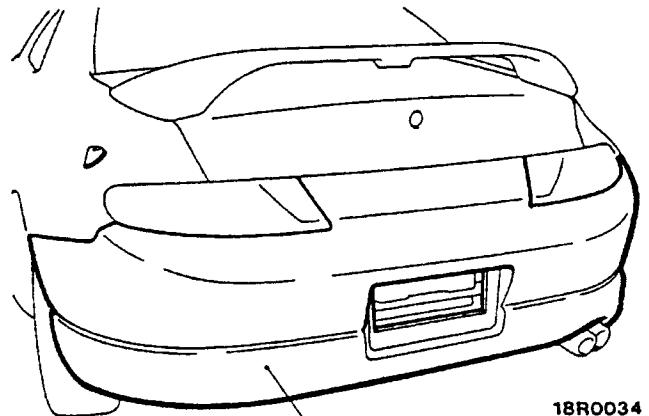

Rear bumper

18R0034

00008609

## AERO PARTS

Aero parts with the following features have been set.

- In addition to improving the aerodynamic characteristics, a powerful and sporty image side airdam and rear spoiler have been adopted.

- To effectively use resources, recyclable olefine-based plastic (PP) has been used for the side airdam material.

### CONSTRUCTION DIAGRAM

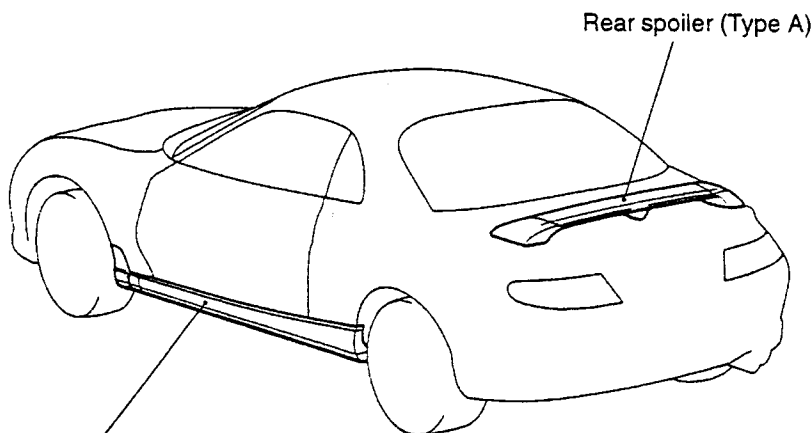

Side airdam

18R0041

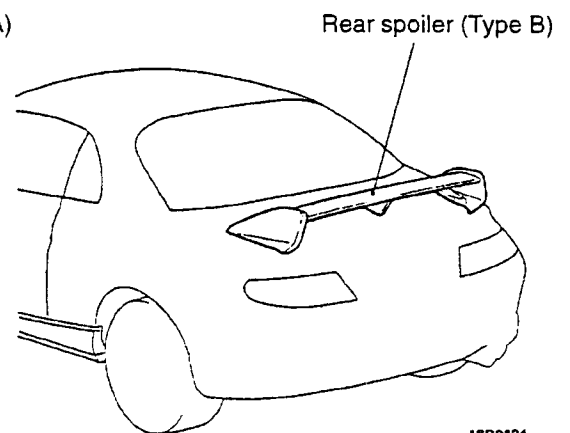

18R0124  
00008610

### OUTSIDE MIRROR

A folding type door mirror, having the following features, has been incorporated for the outer side mirror.

- A motor driven storage type remote controlled door mirror has been adopted.
- A flag type, with small wind noise, has been adopted.

- A groove has been set between the door mirror's visor section and mirror housing to prevent raindrops from adhering on the mirror and door window glass during travel.
- The appearance has been improved by using black for the door mirror's visor section.

### CONSTRUCTION DIAGRAM

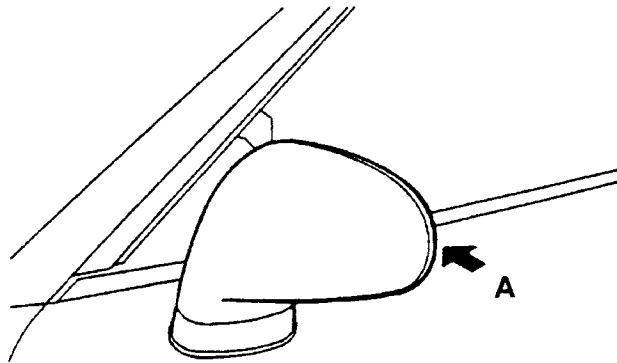

18R0027

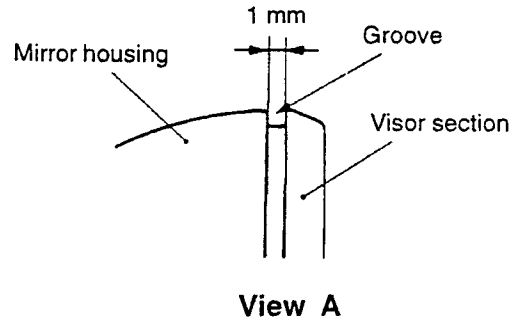

18R0028

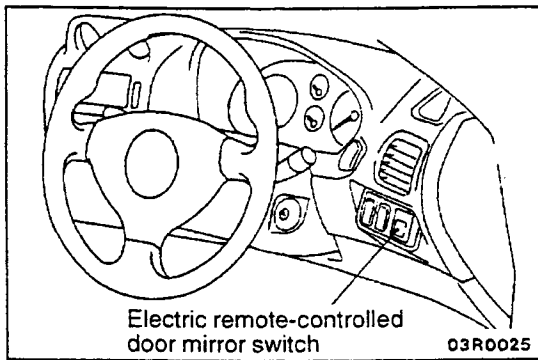

03R0025

00008611

---

# INTERIOR

## CONTENTS

<b>GENERAL DESCRIPTION</b> .....	2	<b>INTERIOR TRIM</b> .....	6
Features .....	2	Construction Diagram .....	6
<b>INSTRUMENT PANEL AND FLOOR CONSOLE BOX</b> .....	3	<b>TRUNK ROOM TRIM</b> .....	6
Construction Diagram .....	3	Construction Diagram .....	6
<b>SEATS</b> .....	4	<b>SRS AIR BAG (DRIVER'S SEAT/ FRONT PASSENGER'S SEAT)</b> .....	7
Construction Diagram .....	4	Construction Diagram .....	7
<b>SEAT BELTS</b> .....	5	SRS Schematic .....	8
Construction Diagram .....	5	Caution Labels .....	9
<b>ROOM MIRROR</b> .....	5	Construction and Operation .....	10
Construction Diagram .....	5		

---

## GENERAL DESCRIPTION

The interior parts are designed to create a sense of sports while laying importance to the vehicle's function, comfort and safety.

### FEATURES

Improved quality feeling

1. Fully trimmed cabin
2. Round-type instrument panel
3. Integral pad on top of the instrument panel

Greater ease of handling

1. Seat mounted seat belt buckle
2. A walk-in system has been incorporated for the front passenger's seat.
3. Cup tray (floor console)

Convenient storage compartment for small articles

1. Center box
2. Glove box
3. Door pocket
4. Floor console

Greater safety

1. Instrument panel padding
2. Three-point seat belts with clamp type ELR (Emergency Locking Retractor)
3. Use of flame-retardant material for upholstery, urethane pads, etc.
4. Supplemental Restraint System (SRS) air bag

Optimum driving position

1. A bucket type front seat laying importance on support has been incorporated.
2. Driver's seat with dual height adjusting mechanism

## INSTRUMENT PANEL AND FLOOR CONSOLE BOX

- (1) The instrument panel is of a round type and has the following features:
- A soft pad covering the instrument panel contributes to safety in the event of an accident and enhances a sense of high quality.
  - A sub-meter is arranged on the centre top of the instrument panel to create a mechanical design that predicts travel.

- The instrument panel has been laid out with importance on the driver's side, allowing the operability and visibility from the driver's position to be improved.
- (2) An ashtray and cup tray with illumination have been set in the floor console.
- (3) Resin parts are marked with the name of the material so that they can be easily identified for recycling purposes.

### CONSTRUCTION DIAGRAM

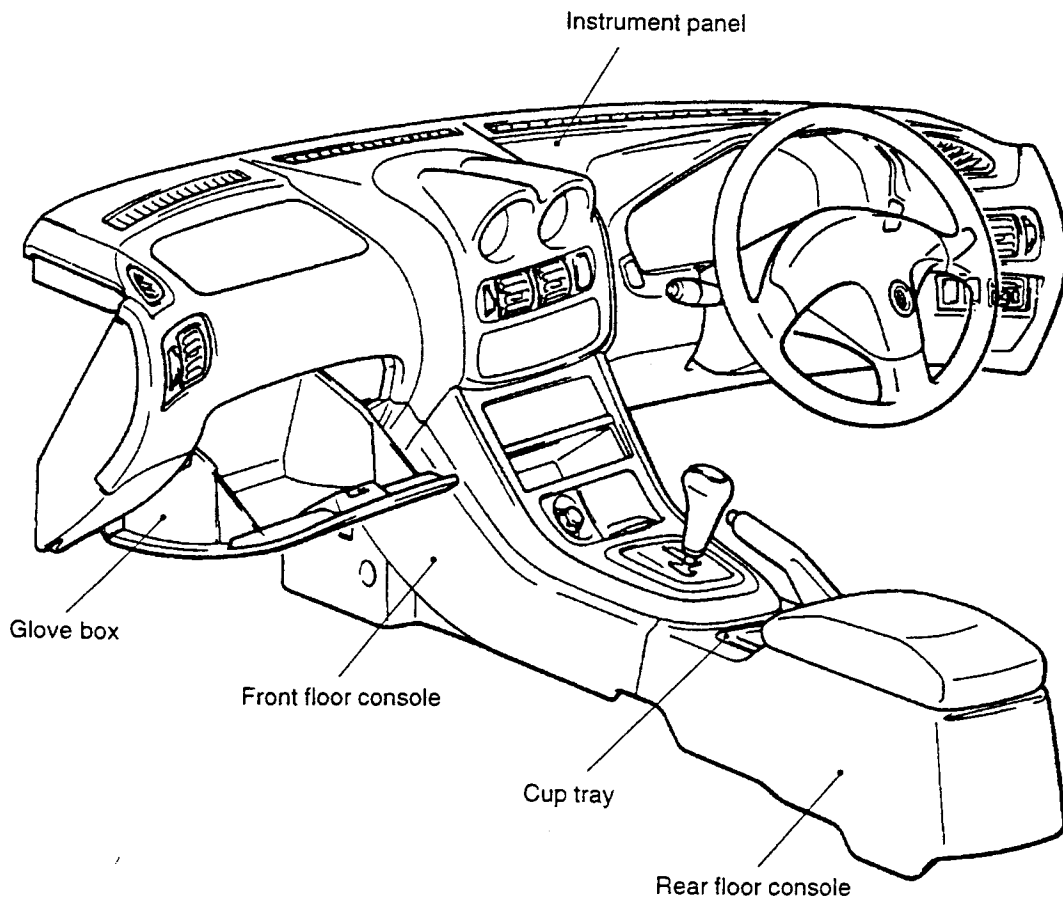

AB21A046



**SEATS**

- (1) A bucket type front seat with integrated head restraint has been incorporated.
- (2) By adopting a dual height (front and rear heights) adjusting mechanism, the driver's seat can be adjusted with a stepless mechanism to obtain the best driving position.
- (3) A walk-in mechanism has been provided for the passenger's seat to ease getting in and out of the rear seats.
- (4) Urethane pads with differing hardness have been incorporated at the centre and side sections of the front seat cushion and back. This improves the seat feel, and improves support.
- (5) A seat belt guide has been set on the front seat back, to improve handling and attaching of the seat belt.
- (6) A bench seat has been used for the rear seat.

**CONSTRUCTION DIAGRAM**

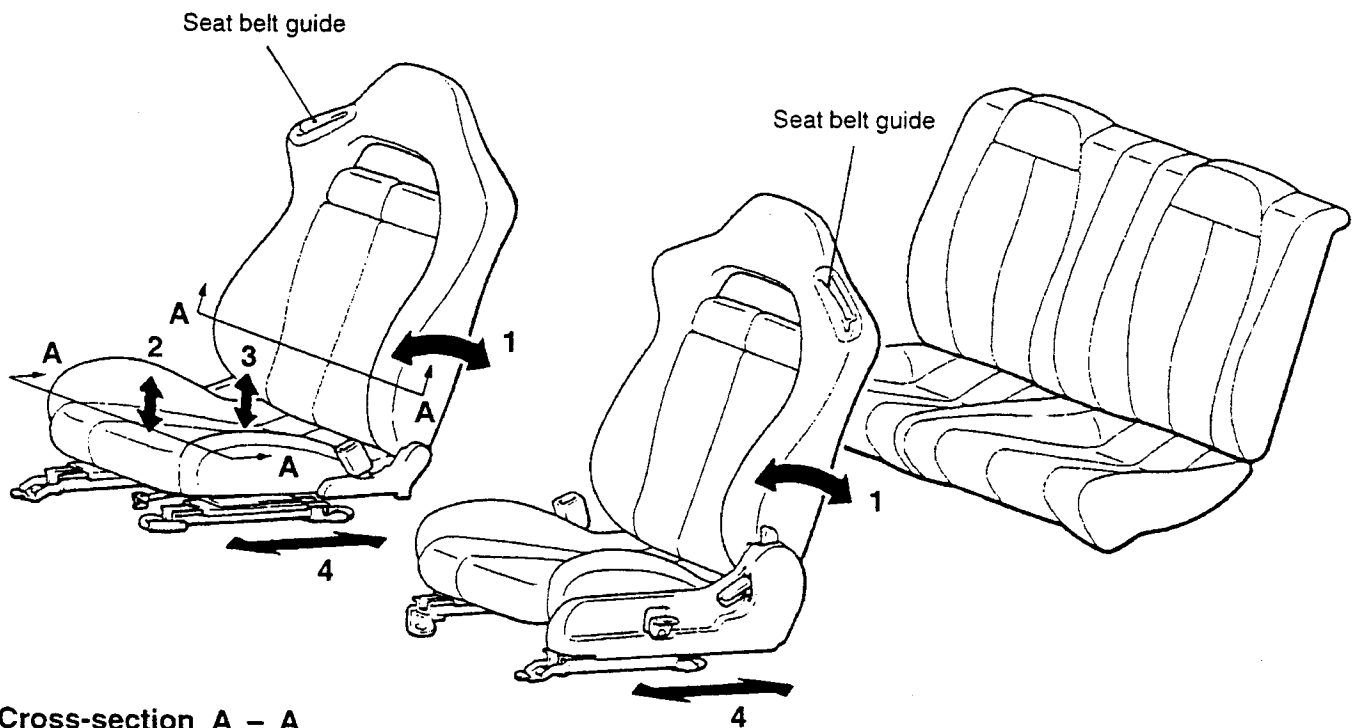

Cross-section A – A

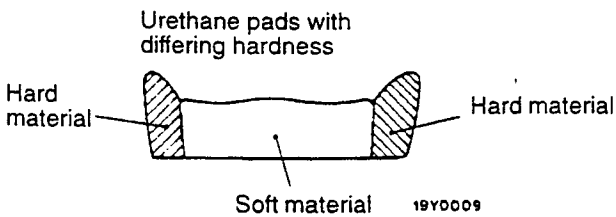

- 1. Reclining adjustment
  - 2. Front height adjustment
  - 3. Rear height adjustment
  - 4. Slide adjustment
- ) Dual height adjustment

19R0001

00008612

## SEAT BELTS

- (1) A three-point type seat belt with ELR, and a seat mounted buckle have been incorporated for the front seat belt.
- (2) A three-point type seat belt with ELR has been mounted for the rear seat belt. In addition, an ELR three-point seat belt with ALR changeover mechanism is set as an option.
- (3) A seat belt warning lamp has been provided on the driver's seat to promote wearing of seat belt when the ignition switch is set to ON. This enhances safety.

### CONSTRUCTION DIAGRAM

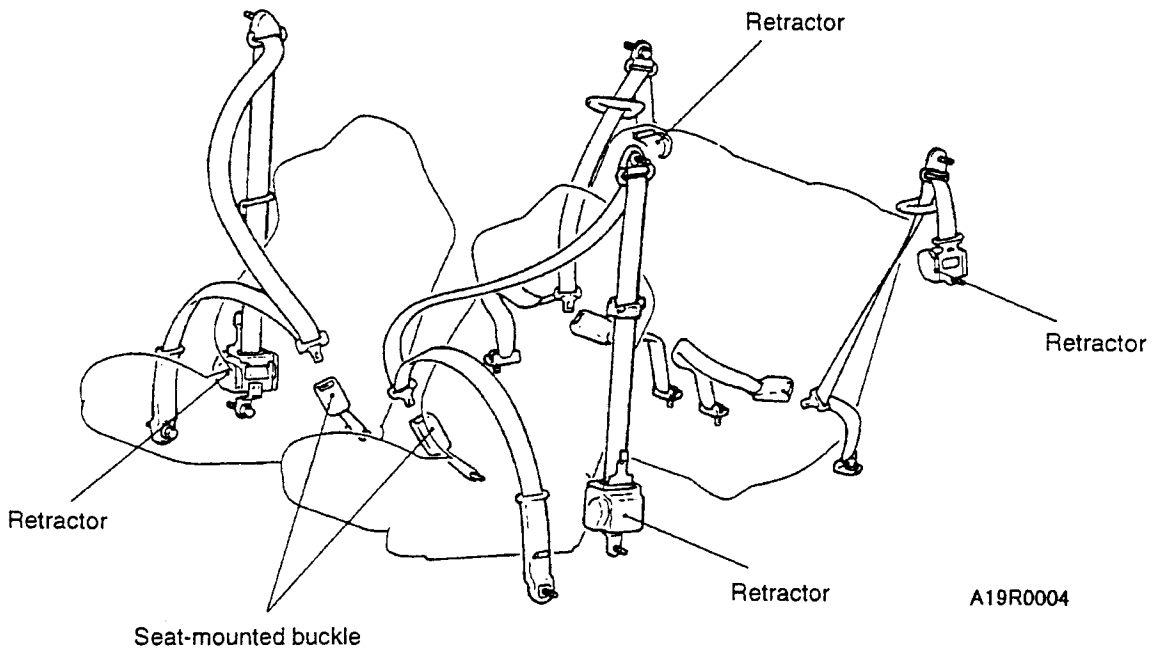

## ROOM MIRROR

An adhesive type room mirror attached to the windshield has been adopted for the room mirror. The functionality as a map lamp built-in type has been emphasized. This map lamp illuminates when the door is opened to function as a room lamp.

### CONSTRUCTION DIAGRAM

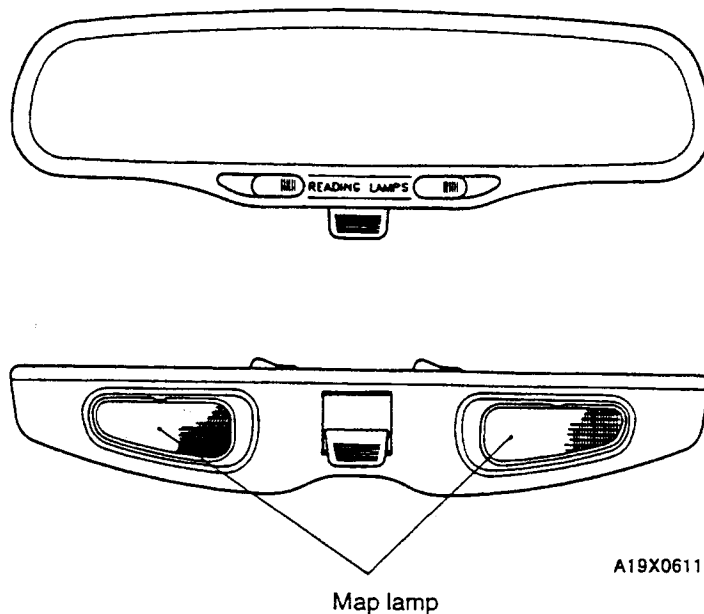

## INTERIOR TRIM

- (1) The interior has been fully trimmed to enhance the marketability.
- (2) A sense of continuity is attained by integrated the rear shelf trim with the speaker garnish.
- (3) Flame-retardant material is used for the upholstery, urethane and pad, etc., to enhance safety and create an outstanding room feel.
- (4) The scuff plate and each trim are marked with the name of the material so that they can be easily identified for recycling purposes.

### CONSTRUCTION DIAGRAM

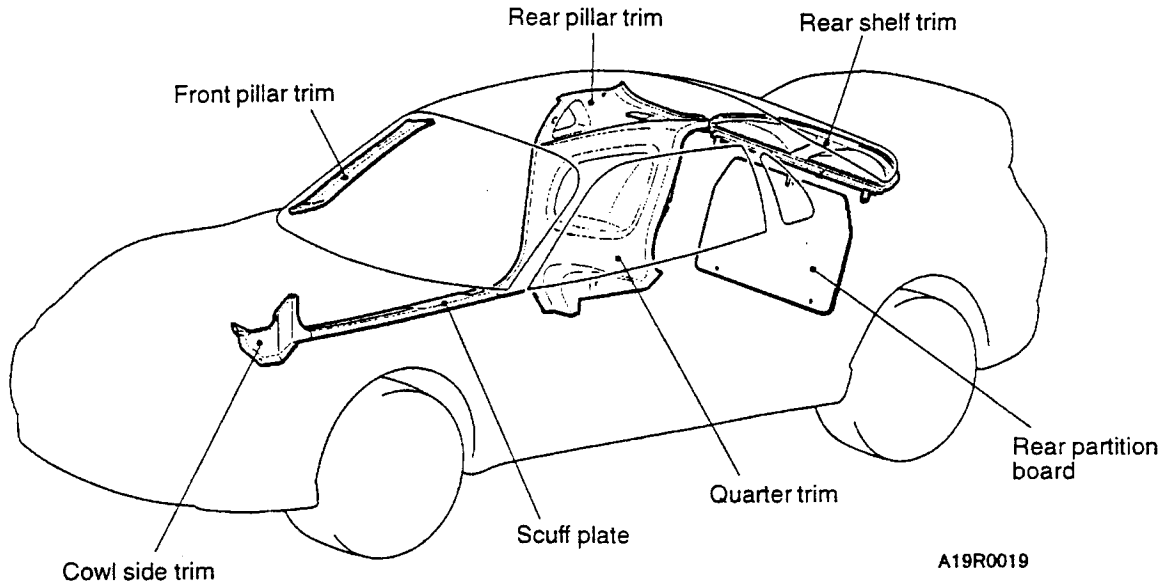

## TRUNK ROOM TRIM

- (1) Soft material trim is used for the trunk room trim to enhance the high-class sense and protect articles placed in the trunk.
- (2) Rear end trim cover is marked with the name of material so that they can be easily identified for recycling purposes.

### CONSTRUCTION DIAGRAM

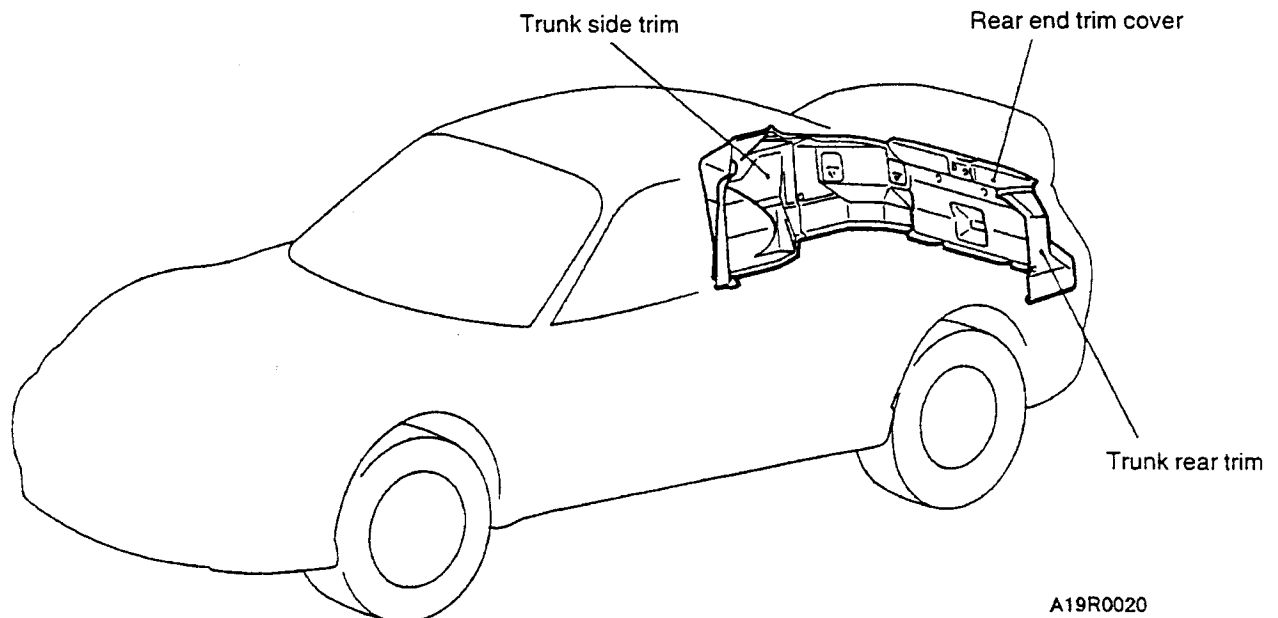

## SRS AIR BAG (DRIVER'S SEAT/FRONT PASSENGER'S SEAT)

An SRS air bag (driver's seat/front passenger's seat) has been set. The SRS is a system that is fully utilized when seat belts are worn, and is designed as an auxiliary system for the seat belt. The SRS air bag is deployed only when an impact exceeding the set value is applied on the entire vehicle during a front-on collision. The upper body of the front seat passengers is protected.

The SRS air bag consists of the SRS air bag control unit (SRS-ECU), air bag module, clock spring, and SRS warning lamp, etc. A single point method in which the analog G sensor, safing G sensor and collision judgment circuit are concentrated in the SRS-ECU is incorporated.

### CONSTRUCTION DIAGRAM

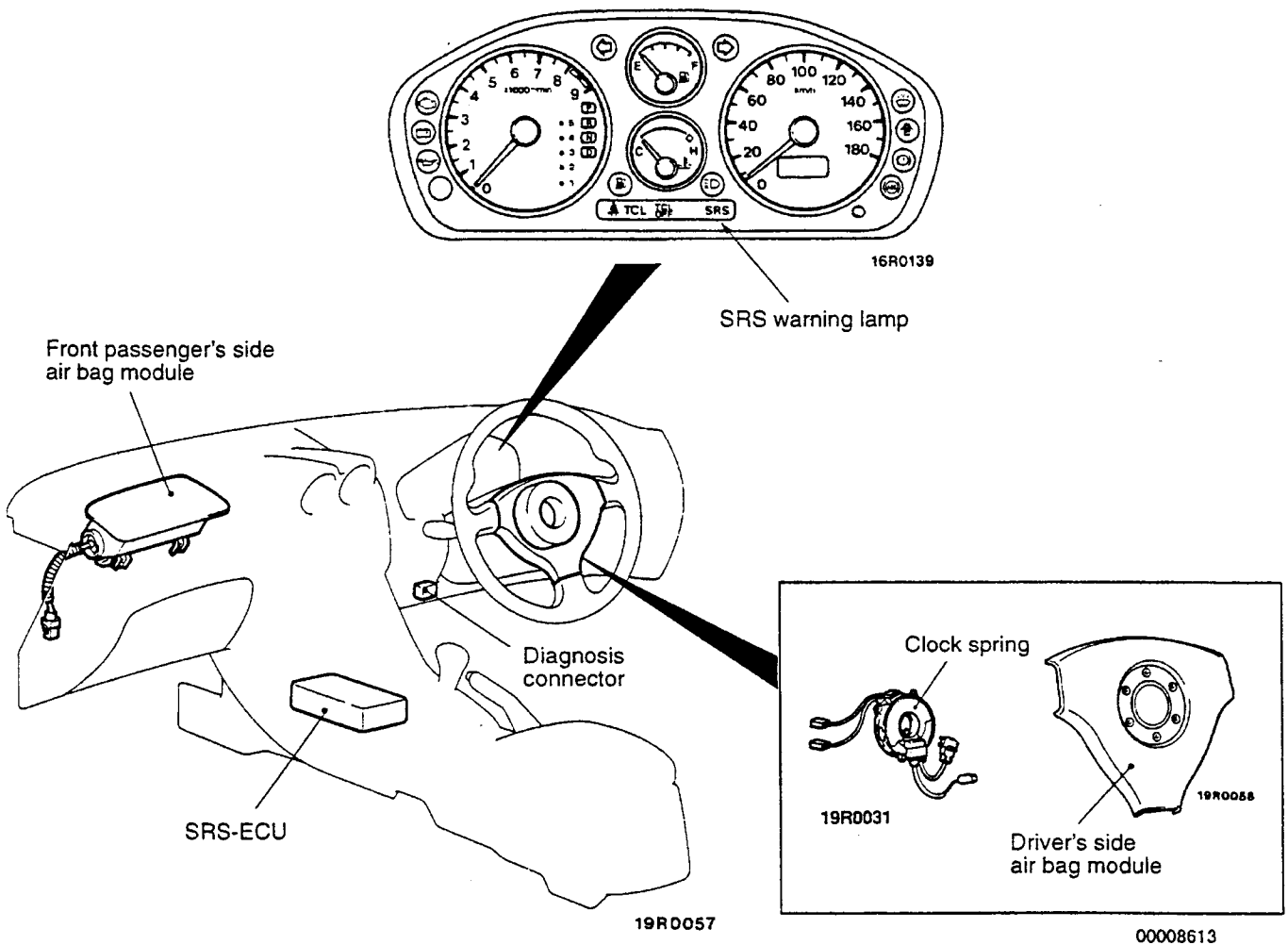

SRS SCHEMATIC

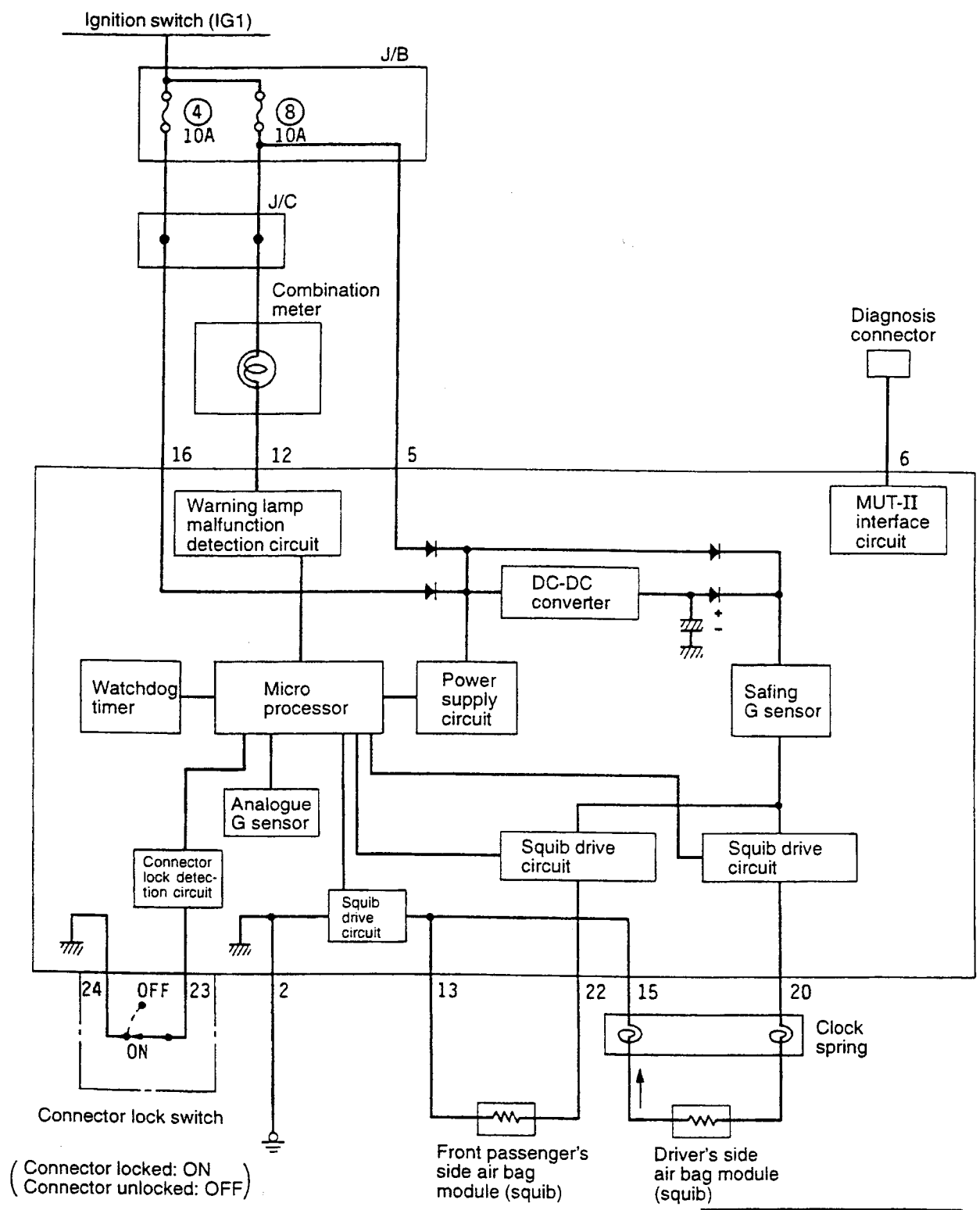

( Connector locked: ON  
 Connector unlocked: OFF )

				23						24					
1	2	3	4	5	6	7	8	9	10	11	12				
13	14	15		16	17	18	19		20	21	22				

SRS-ECU connector terminal arrangement

**CAUTION LABELS**

Labels indicating cautions to be taken when handling or servicing the SRS air bag are attached at the following positions (positions A to G).

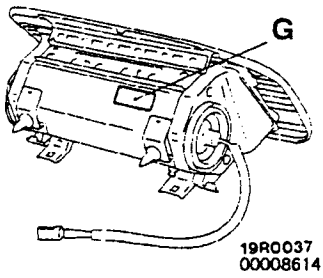
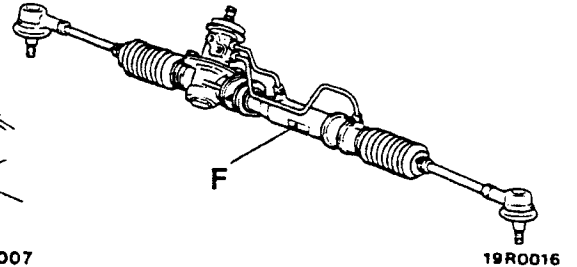
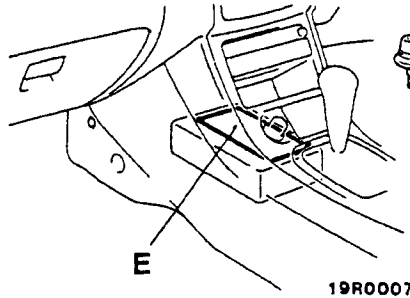
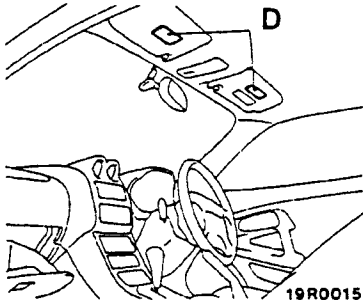
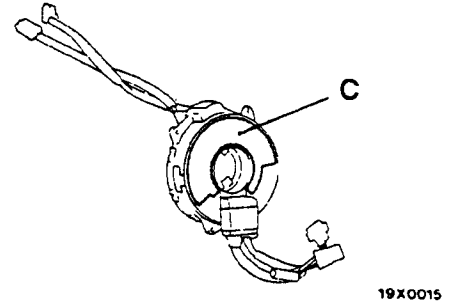
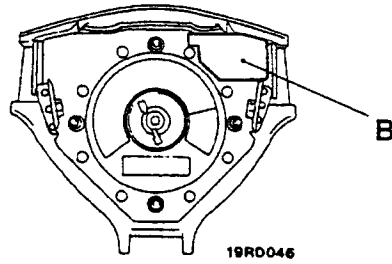
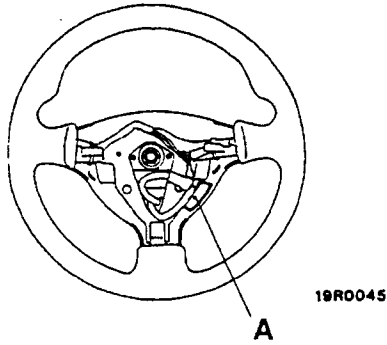

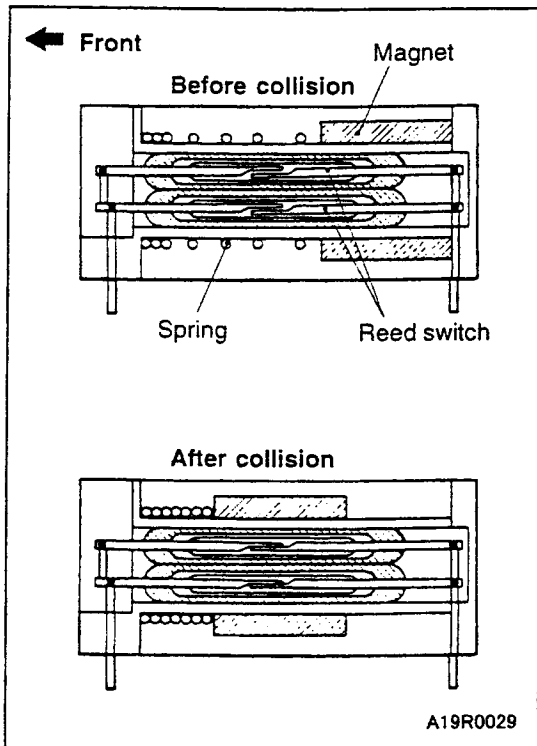

## CONSTRUCTION AND OPERATION

### SAFING G SENSOR

The safing G sensor consists of a spring, magnet and reed switch.

When the sensor receives a force through a collision, the magnet compresses the spring forwards by inertial force. Then the magnet closes the contacts of the reed switch, thereby generating current.

---

# EQUIPMENT

## CONTENTS

<b>GENERAL DESCRIPTION</b> .....	2	<b>COMBINATION METER</b> .....	7
Features .....	2	<b>SUB METER</b> .....	7
<b>DIAGNOSIS SYSTEM</b> .....	3	Construction Diagram .....	7
Diagnosis Connectors .....	3	<b>WIPERS AND WASHERS</b> .....	8
<b>BATTERY</b> .....	3	Windshield Wipers and Washers .....	8
Specifications .....	3	Rear Wiper and Washer .....	8
<b>IGNITION SWITCH</b> .....	4	<b>SPEAKER AND ANTENNA</b> .....	9
Dual-Action Ignition Switch (Ignition Key Push Type) <M/T> .....	4	Construction Diagram .....	9
<b>LIGHTING</b> .....	4	<b>HEATER AND AIR CONDITIONER</b> .....	10
Exterior Lamp .....	4	Features .....	10
Specifications .....	4	Specifications .....	11
Construction and Operation .....	5	Construction Diagram .....	12
Interior Lamp .....	6	Construction and Operation .....	13
Specifications .....	6	Diagnosis and Fail-Safe Functions .....	14
Construction Diagram .....	6		

---



## GENERAL DESCRIPTION

Equipment has been strengthened with new equipment and new functions.

### FEATURES

#### Improved reliability

1. Electronic control system terminals are treated with gold plating
2. Incorporation of MWP (Multipole Water-proof Type) connector
3. Incorporation of junction block for centralized connection of fuse box, relay box and intermediate connectors

#### Improved visibility and safety

1. Use of a dual-action ignition switch (ignition key push type) to prevent ignition key from being unintentionally removed during travel causing the steering wheel to lock <Vehicles with M/T>
2. Mounting of high-mounted stop lamp
3. Mounting of large-sized combination meter
4. Mounting of sub meter

#### Improved serviceability

1. Mounting of diagnosis connector for MUT-II inspection
2. Mounting of exclusive connector for engine revolution speed detection
3. Use of one-touch plug in (direct insertion into device) allowing easy attachment and removal of combination meter

#### Improved marketability

1. Mounting of electric speedometer
2. Mounting of odometer and trip meter with one-touch selection LCD

## DIAGNOSIS SYSTEM

The diagnosis connector for the MUT-II inspection has been set near the left knee area of the driver's seat to improve serviceability.

Diagnosis functions	MPI	ELC-5A/T	ABS	Full automatic air conditioner	SRS
Diagnosis code output	○	○	○	○	○
Service data output	○	○	○	○	
Actuator test	○	○	○	○	
Simplified inspection code output (Same indication pattern as for diagnosis code)	○	○	○	○	
Diagnosis code retained in memory	○ (until battery is OFF)		○	○ (until battery is OFF)	○ (EEPROM)*
Diagnosis code erased by MUT-II	○	○	○	○	○

### NOTE

\*: Data is retained in memory until it is electrically cleared.

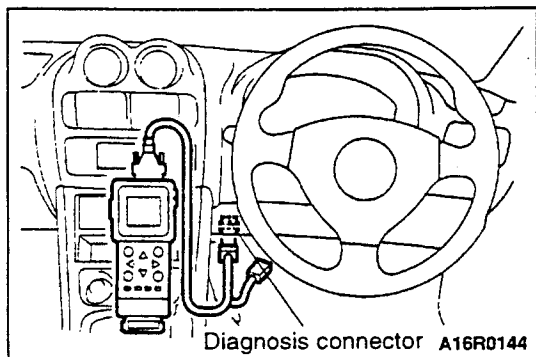

## DIAGNOSIS CONNECTORS

1	Diagnosis control
2	-
3	-
4	Earth
5	Earth
6	-
7	MPI, ELC-5A/T, TCL, ABS
8	-
9	-
10	-
11	Full automatic air conditioner
12	SRS
13	-
14	-
15	-
16	Battery (DC 12 V)

## BATTERY

The battery of the following specifications has been established.

### SPECIFICATIONS

Type	46B24R (S)
Voltage V	12
Capacity (5HR) Ah	36
Electrolyte specific gravity (20°C fully charged)	1,280

## IGNITION SWITCH

### DUAL-ACTION IGNITION SWITCH (IGNITION KEY PUSH TYPE) <M/T>

The dual-action ignition switch (ignition key push type) is installed in the manual transmission vehicles to prevent the steering wheel from locking as a result of the ignition key being inadvertently removed during travel. This contributes to greater

safety. For additional convenience, an ignition switch illumination lamp, which illuminates for approximately 10 seconds with the buzzer ECU's timer function, has been adopted.

## LIGHTING

### EXTERIOR LAMP

(1) A rectangular 4-bulb type headlamp with sporty design is used, and halogen bulbs with outstanding light distribution are set in all vehicles.

- A non-cut lens is adopted for the outer lens.
- A free curving reflector type is adopted for the high-beam side.

- A projector type is adopted for the low-beam side, and the discharge headlamp is set as an option.

(2) A sporty rectangular shape is used for the rear combination lamp.

### SPECIFICATIONS

Items		Specifications
Headlamp	Low beam	51 W or 35 W*
	High beam	60 W
Turn-signal lamp		21 W
Fog lamp		55 W
Side turn-signal lamp		5 W
Rear combination lamp	Turn-signal lamp	21 W
	Tail/stop lamp	5/21 W × 2 bulbs
	Back-up lamp	21 W
Licence plate lamp		5 W

NOTE: \* mark indicates discharge headlamp wattage.

## CONSTRUCTION AND OPERATION

## Discharge Headlamp

The discharge headlamp consists of the controller that converts the power supply from the battery into an AC high voltage, and the discharge bulb.

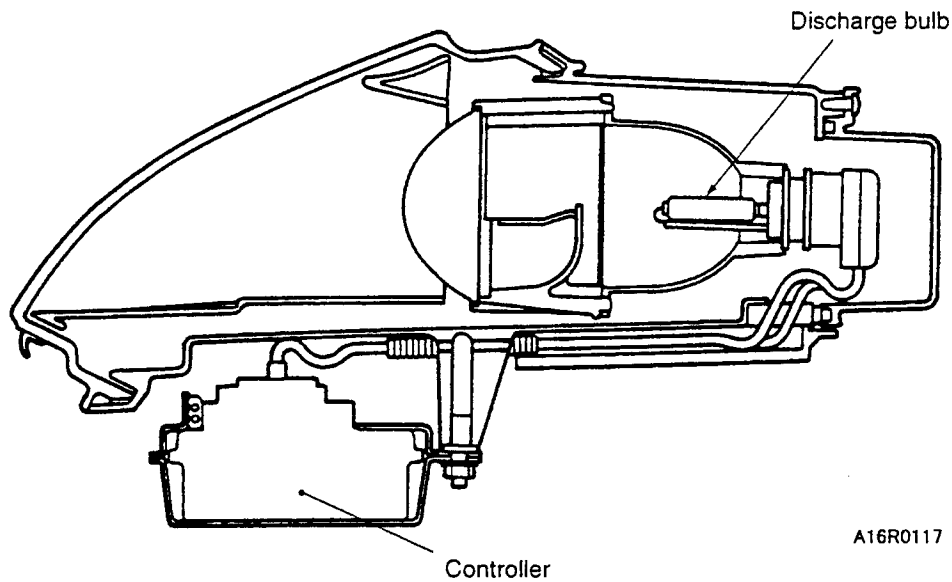

## Light Emission Mechanism

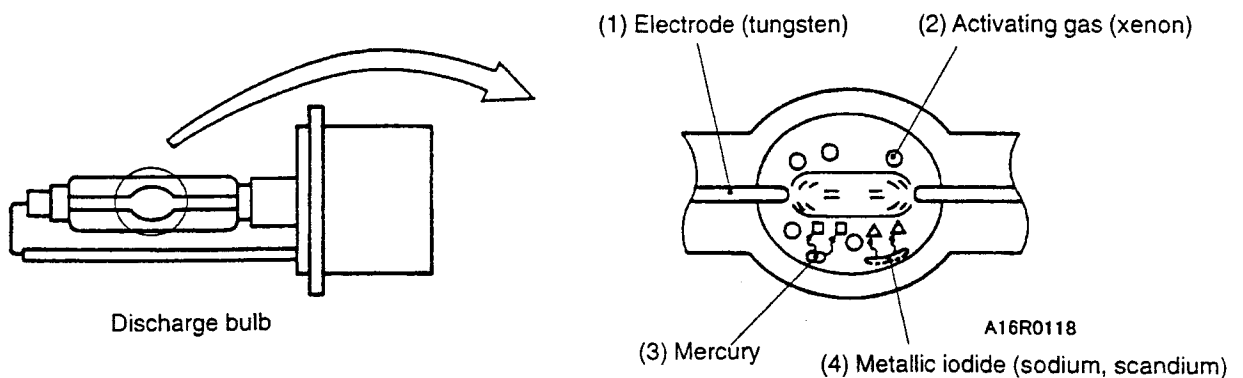

1. By applying a high voltage between the (1) electrodes, the (2) activating gas (xenon) discharges as sparks.
2. As the temperature in the tube rises, the (3) mercury vaporizes creating an arc electrical discharge.

3. When the temperature rises further, the (4) metal iodides vaporize, and decompose into metallic atoms and iodide atoms.
4. The decomposed metallic atoms discharge in a spectre unique to metal by the thermal energy.

## Caution

- (1) The discharge headlamp controller generates a high voltage of approx. 20,000 V. Take great care when carrying out a service about the discharge headlamp.

- (2) Always contact your Mitsubishi dealer for removal or exchange.

**INTERIOR LAMP**

(1) A map lamp built into the room mirror is incorporated. The lamp lights when the door is open, to function as a room lamp.

(2) A roof mounted type lamp with bulb has been used for the high-mounted stop lamp to improve safety.

**SPECIFICATIONS**

Items	Specifications
Map lamp	8 W x 2 bulbs
High-mounted stop lamp	5 W x 2 bulbs
Trunk room lamp	5 W

**CONSTRUCTION DIAGRAM**

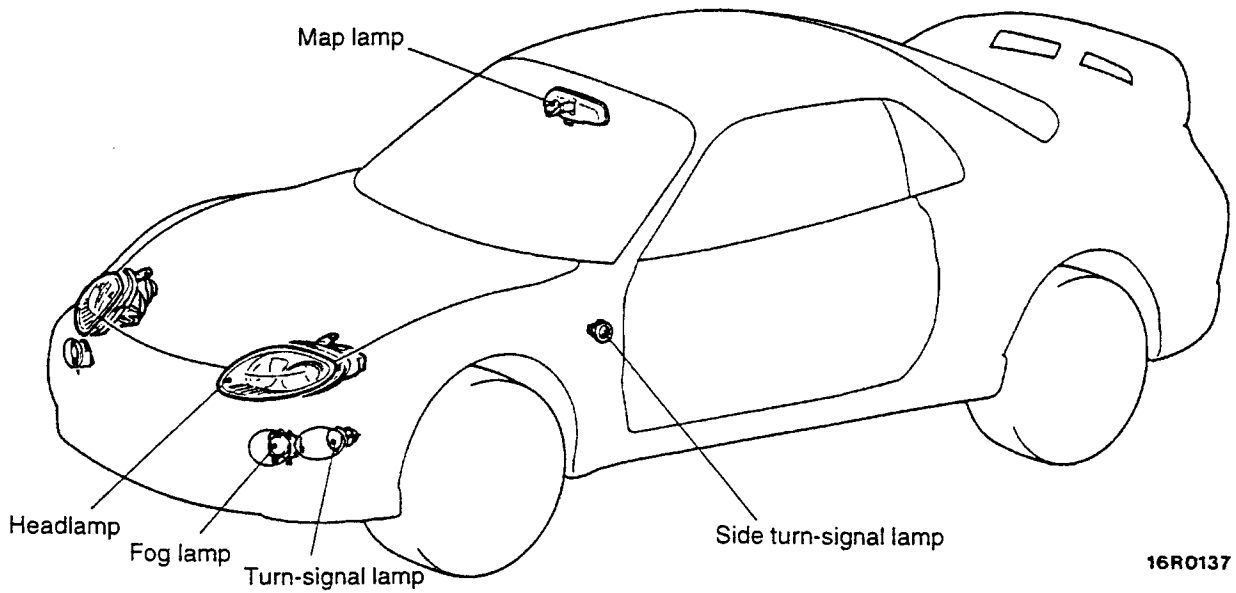

16R0137

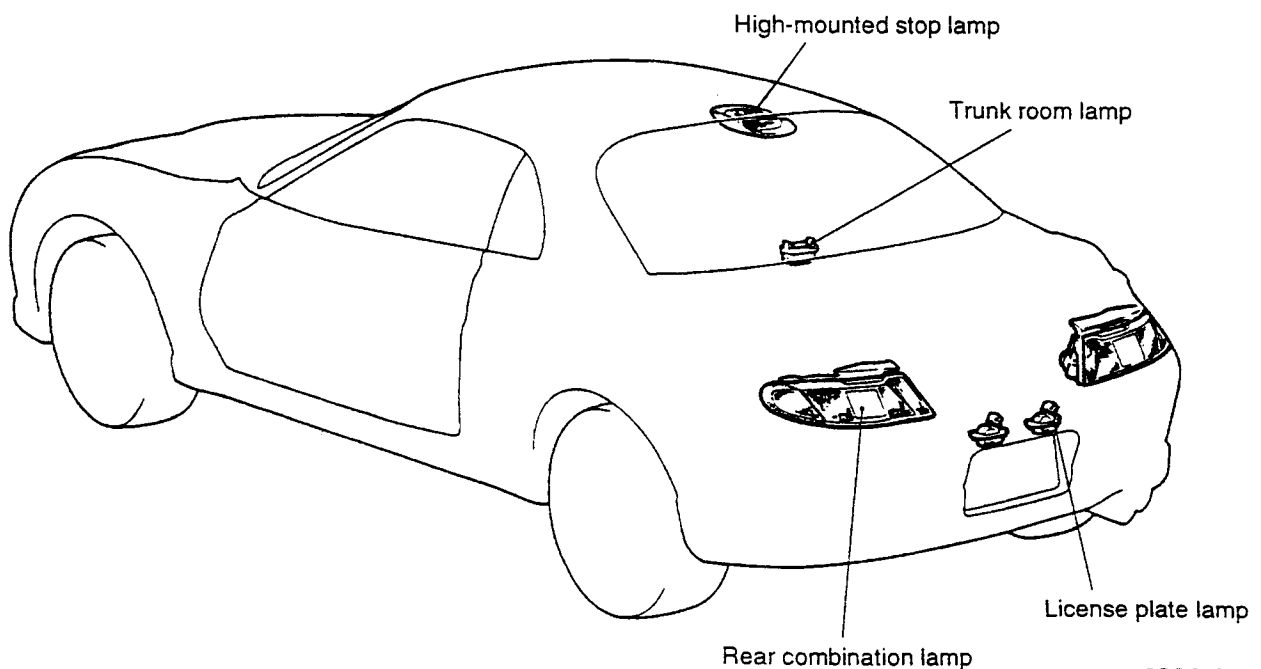

16R0018  
00008615

## COMBINATION METER

A large easy-to-see needle type meter with indicator lamp and warning lamps, etc., has been incorporated for the combination meter.

- An electric speedometer that operates with the pulse signals from the vehicle-speed sensor has been incorporated for the speedometer.
- The speedometer, tachometer, fuel gauge and water temperature gauge are separated with each meter enclosed in a ring, allowing the

driver to easily identify and recognize the information on each meter.

- A liquid crystal display method has been used for the odometer and trip meter.
- A seat belt warning lamp has been provided to promote wearing of seat belt.
- White transmitted illumination is used for the night time illumination, and needle illumination has been used to improve visibility at night.

## SUB METER

A voltmeter and clock have been mounted at the upper centre of the instrument panel as sub displays of the combination meter.

- An easy-to-read analog type clock has been used.
- As with the combination meter, the periphery

of the meters has been enclosed with a ring to unify the design.

- As with the combination meter, white transmitted illumination is used for the night time illumination, and needle illumination has been used to improve visibility at night.

## CONSTRUCTION DIAGRAM

SUB METER

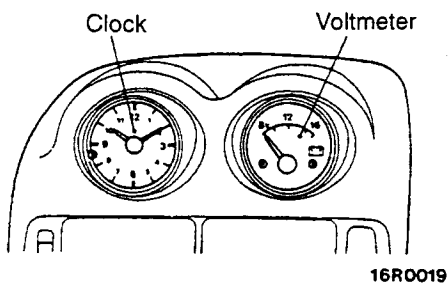

COMBINATION METER

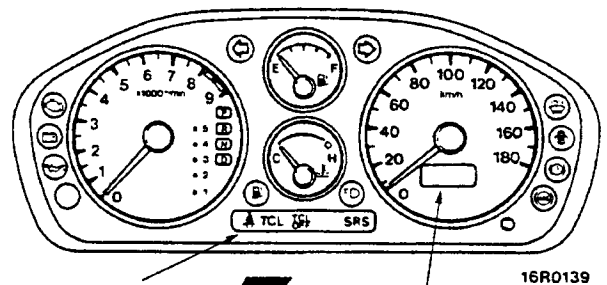

Seat belt warning lamp

Liquid crystal display type odometer and trip meter

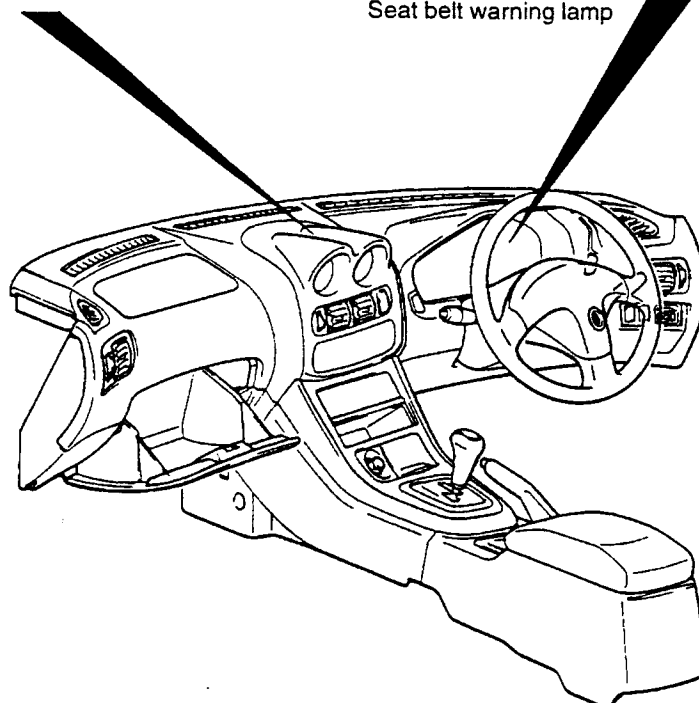

## WIPERS AND WASHERS

### WINDSHIELD WIPERS AND WASHERS

A two-speed type windshield wiper that operates at low speeds and high speeds has been used. In addition, a variable intermittent wiper function has been adopted. They also offer the following features.

- A washer interlocked wiper function and mist wiper function have been adopted for greater convenience.
- The washer nozzle is a 2-nozzle, 4-jet type.

### REAR WIPER AND WASHER

The rear wiper has an intermittent wiper function for better rear visibility in the event of a light rain. (Option)  
It offers the following features.

- The washer nozzle adopted is a 1-nozzle, 1-jet type.
- The washer tank serves also as the windshield washer tank to improve serviceability.

### CONSTRUCTION DIAGRAM

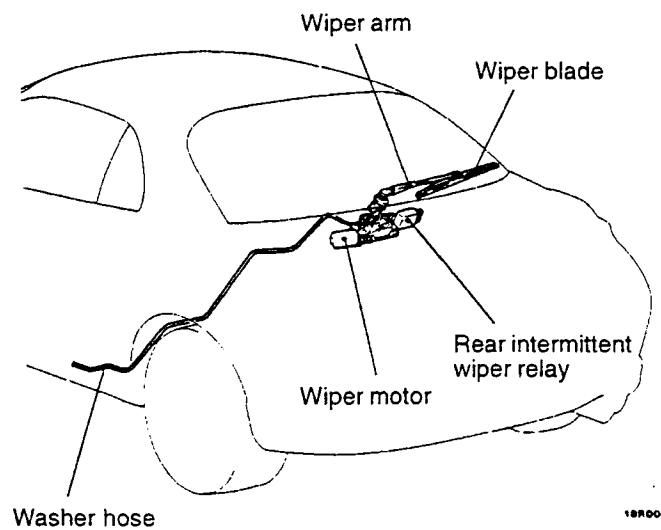
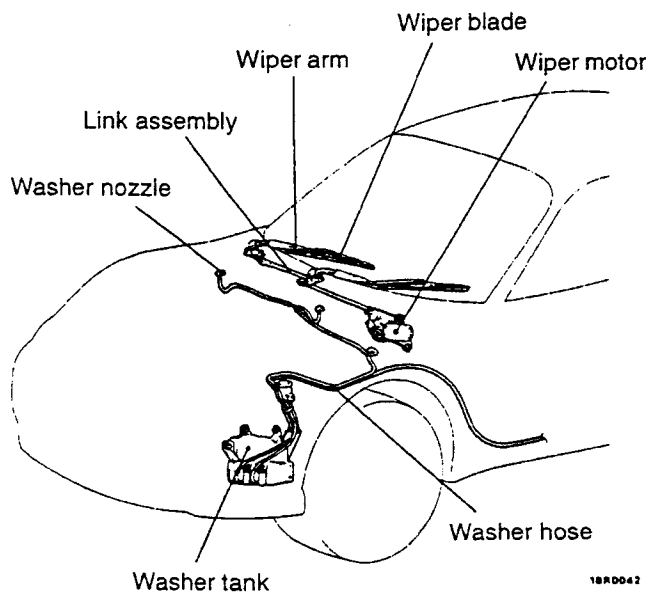

## SPEAKER AND ANTENNA

For the speakers and antenna, six speakers and an FM diversity antenna (motor antenna with half position + rear glass antenna) have been incorporated.

### Caution

Sticking window film (mirror type) on the glass where the antenna is mounted or scratching the antenna printed section could lead to a drop in the reception.

## CONSTRUCTION DIAGRAM

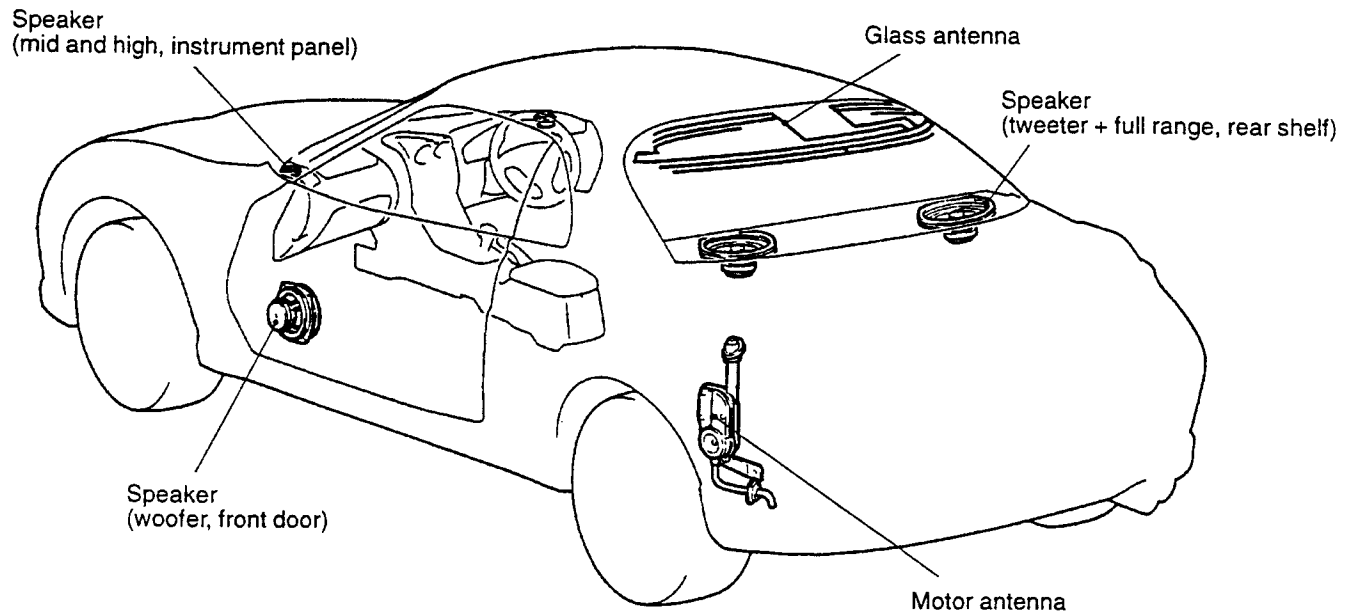

A16R0136



## HEATER AND AIR CONDITIONER

The heating system is a high-performance and low-noise full-air-mix system that provides a two-layer stratified air flow.

An automatic air conditioner has been set for the air conditioning system, and a new refrigerant system corresponding to CFC controls has been used to protect the ozone layer.

### FEATURES

Improvement in comfort

1. Improved humidity control response with two-layer stratified air flow type full-air-mix heater.
2. Independent face-level air flow function capable of sending air constantly from the side ventilators.
3. Scroll type variable delivery air compressor that offers improved cooling performance and quietness.

Easy control

1. Automatic control of air conditioning with automatic air conditioner.
2. Integrated AUTO switch and dial type temperature setting switch.
3. Rear defogger switch with timer function by A/C-ECU.
4. Air conditioning operation monitoring by symbols on liquid crystal display.

Maintenance of visibility  
(for enhanced safety)

1. Independent face-level air flow from side ventilators.
2. Improved ventilation performance with increased ventilation air rate
3. Wide-flow defroster nozzle

Protection of global environment

1. Adoption of new refrigerant

Improvement in reliability and serviceability

1. Additional diagnosis functions accommodatable to the MUT-II.
2. Adoption of flange fitting design and O-ring slip-off preventing construction for piping joints to improve serviceability and reliability.
3. A/C-ECU integrated in air conditioner panel

## SPECIFICATIONS

## HEATER

Items	Specifications	
Temperature control	Two-layer stratified flow type fuel-air-mix method	
Heating capacity kJ/h	17,581	
Air capacity m <sup>3</sup> /h	290	
Consumed power W	200	
Blower	Motor speed r/min	3,500
	Fan type	Sirocco fan
	Air capacity changeover	15-steps for heating, 17-steps for cooling

## AIR CONDITIONER

Items	Specifications	
Cooling capacity kJ/h	17,581	
Compressor	Type	MSC90 [Mitsubishi Heavy Industries scroll type]
	Discharge quantity ml/rotation	90
	Applicable oil amount ml	120 $\begin{smallmatrix} +20 \\ -0 \end{smallmatrix}$
	Applicable oil	SUN PAG56
	Clutch type	Dry single-plate magnet type
Cooling unit type	Aluminum laminated type	
Condenser type	Aluminum multi-flow type	
Condenser fan motor type	Puller type	
Refrigerant	Type	R134a (HFC-134a)
	Injection amount g	630 – 670

**CONSTRUCTION DIAGRAM  
HEATER AND AIR CONDITIONER**

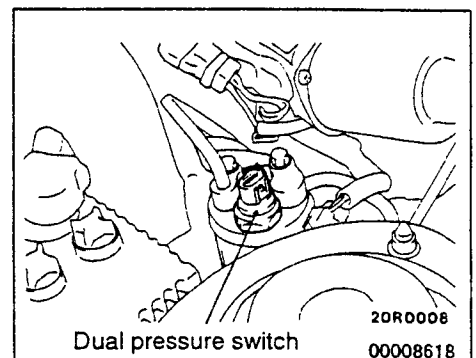
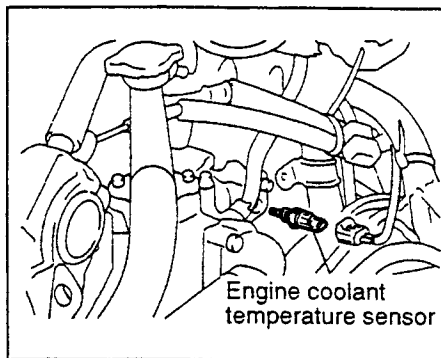
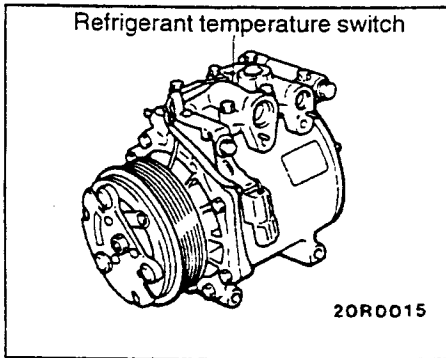
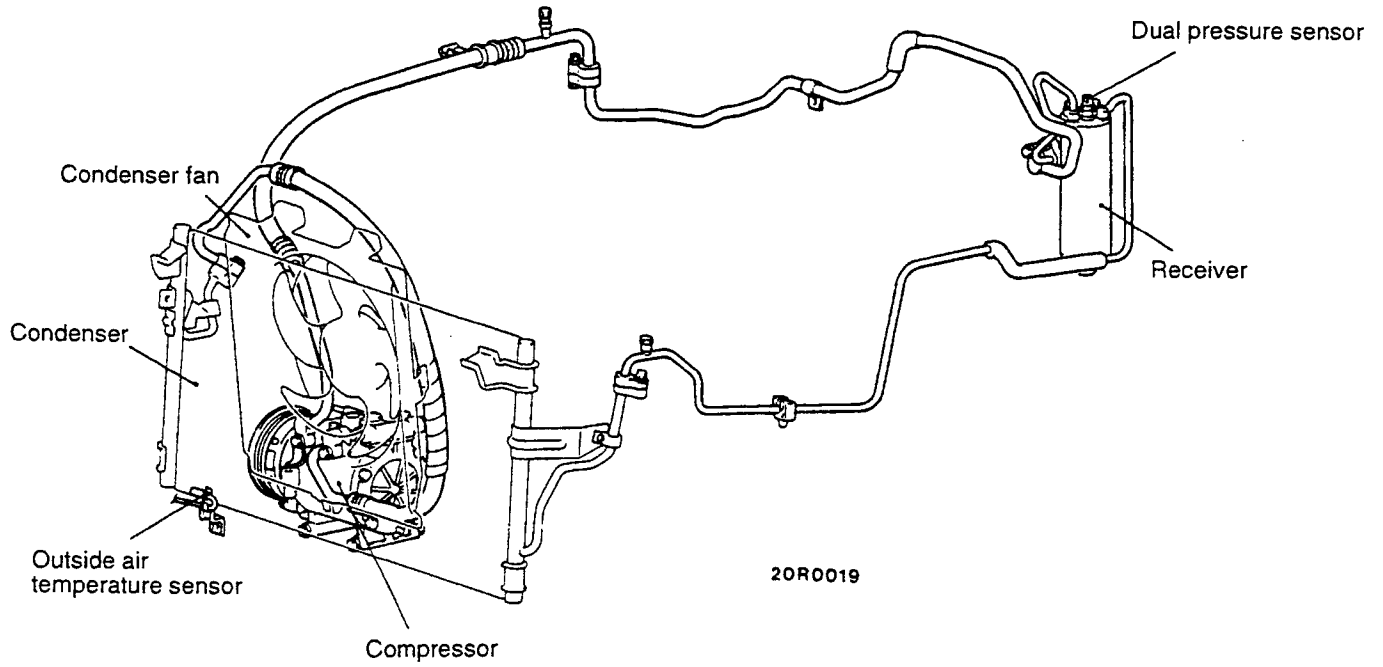

**VENTILATION**

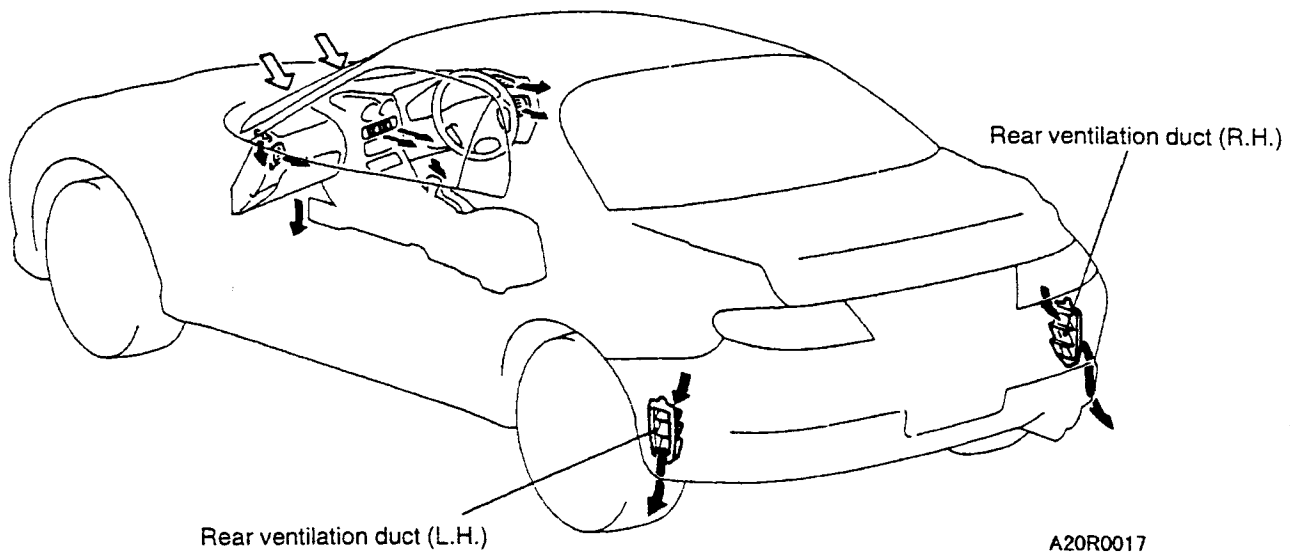

**CONSTRUCTION AND OPERATION**

**HEATER AND AIR CONDITIONER**

- (1) The air conditioner's control panel has an integrated AUTO switch and temperature setting switch. Slits for the room temperature sensor are provided around this. A rear defogger switch with timer has also been built-in.
- (2) A bell mouth shape\* has been used for the indoor/outdoor air intake port of the blower fan, allowing the air capacity to be increased and the noise to be lessened.

- (3) By increasing the bumper opening area and incorporating an air guide panel, the cooling performance of the condenser fan has been improved and the motor has been downsized.

**NOTE**

\* Bell mouth shape: Shape that widens like the mouth of a bell.

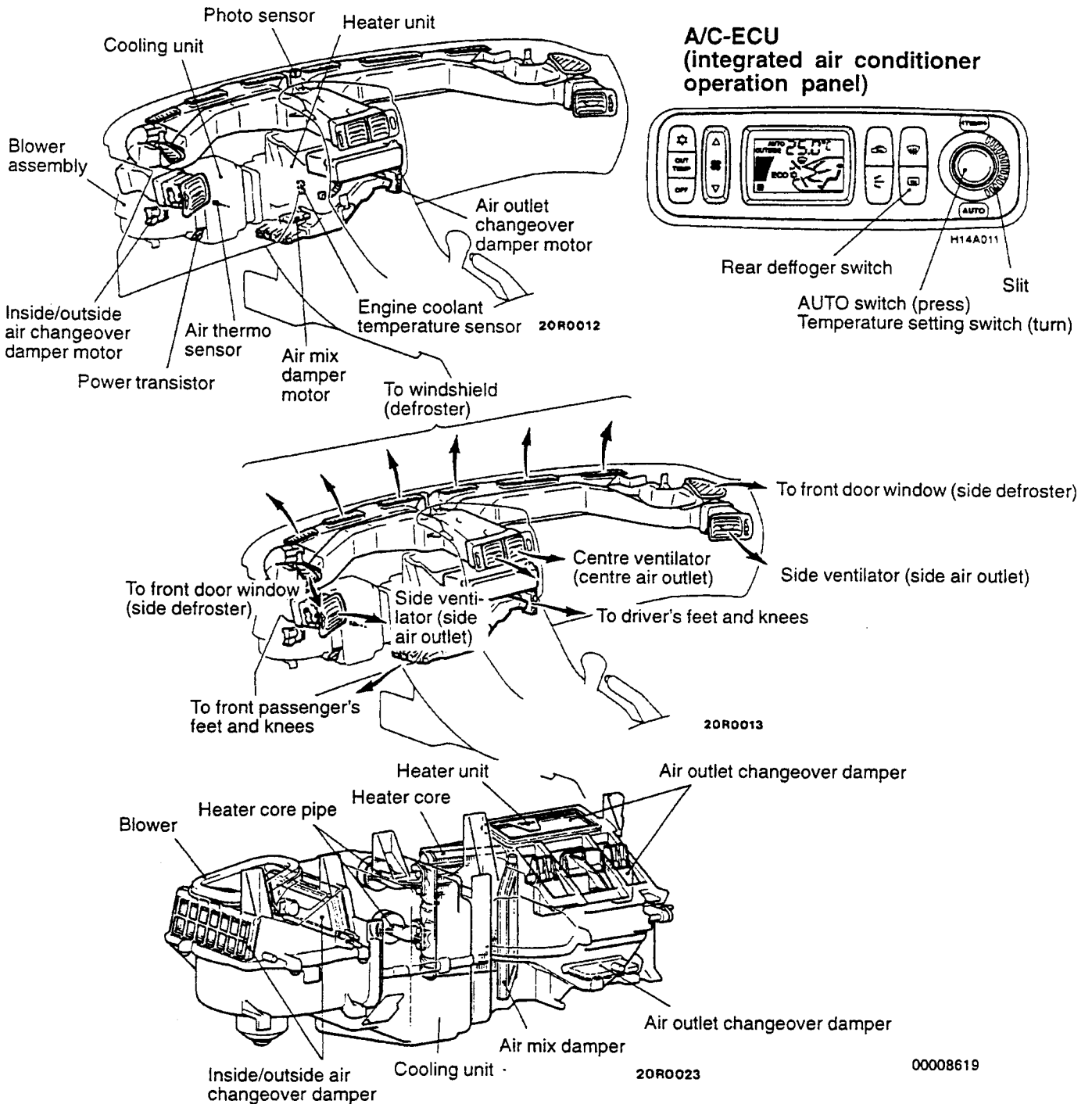

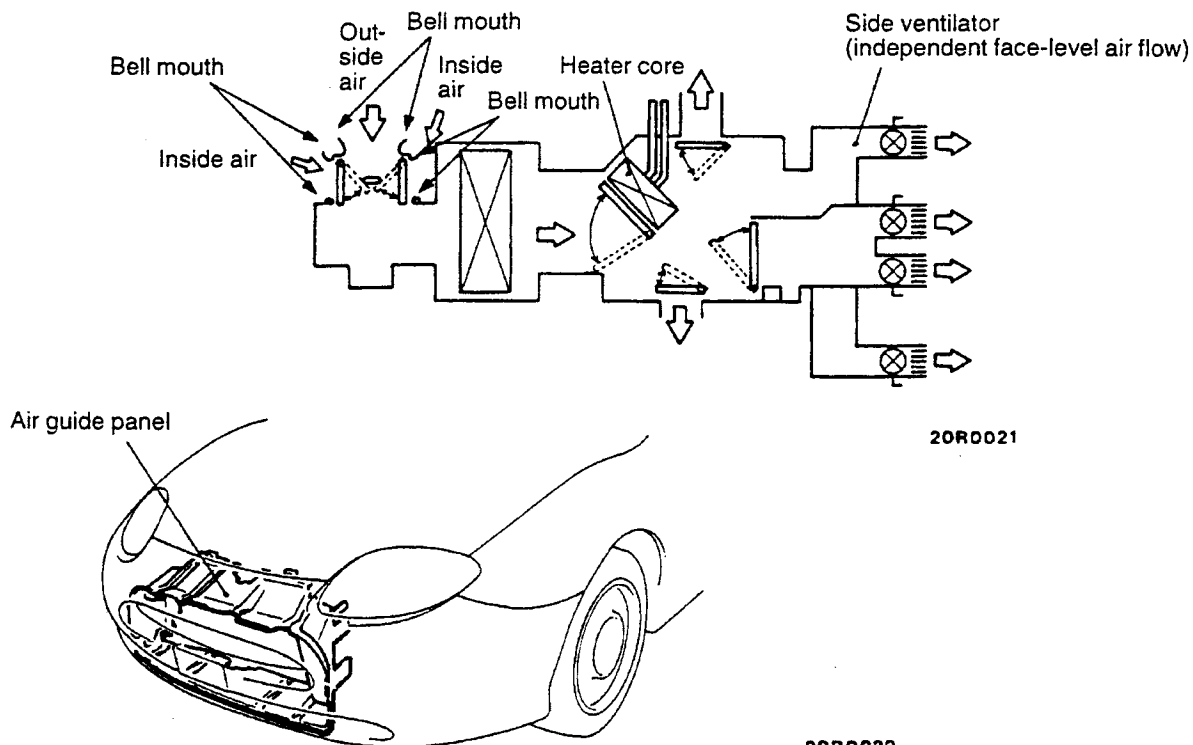

20R0021

20R0020  
00008620

## DIAGNOSIS AND FAIL-SAFE FUNCTIONS

- (1) Troubleshooting has been made simple and accurate by incorporating a self diagnosis function that diagnoses faults in the 12 systems and faults in the A/C-ECU.
- (2) When a system error is detected, the error place is output to the diagnosis connector set at the side of the junction block. The MUT-II or analog voltmeter is used for inspection.
- (3) In addition to the fault code No., display, a fail-safe function is provided, to fail-safe system trouble caused by faults.
- (4) If two or more errors occur, each error code No. is repeatedly displayed in order from the smallest No. The code No. can be erased by turning the battery power OFF or operating the MUT-II.

## DIAGNOSIS

Output code No.	Fault system	Fail-safe function and vehicle condition
0	[Normal]	[Normal]
11	Passenger compartment temperature sensor open-circuited	State in which 25°C is detected occurs
12	Passenger compartment temperature sensor short-circuited	
13	Outside air temperature sensor open-circuited	State in which 20°C is detected occurs
14	Outside air temperature sensor short-circuited	
15	Engine coolant temperature sensor open-circuited	State in which 50°C is detected occurs
16	Engine coolant temperature sensor short-circuited	
21	Air thermo sensor open-circuited	State in which 0°C is detected occurs
22	Air thermo sensor short-circuited	
31	Air mix damper potentiometer open-circuited or short-circuited	MAX. HOT occurs
32	Air outlet changeover damper potentiometer open-circuited or short-circuited	DEF. occurs
41	Air mix damper motor malfunction	—
42	Air outlet changeover damper motor malfunction	—

## SERVICE DATA

Check item	Check contents		
	Check condition	Correct judgement value	
Passenger compartment temperature sensor ● MUT-II (11)	Ignition switch: ON	Room temperature and MUT-II display temperature are the same	
Outside air temperature sensor ● MUT-II (13)	Ignition switch: ON	Outdoor temperature and MUT-II display temperature are the same	
Engine coolant temperature sensor ● MUT-II (15)	Ignition switch: ON	Heat core panel temperature and MUT-II display temperature are the same	
Air thermo sensor ● MUT-II (21)	Ignition switch: ON	Evaporator blow-off temperature and MUT-II display temperature are the same	
Photo sensor ● MUT-II (25)	Ignition switch: ON	Quantity of solar radiation and MUT-II display temperature are the same	
Air mix damper potentiometer ● MUT-II (31)	Ignition switch: ON	Damper position	Opening degree (%)
		MAX. HOT	Approx. 100
		MAX. COOL	Approx. 0
Air outlet changeover damper potentiometer ● MUT-II (32)	Ignition switch: ON	Damper position	Opening degree (%)
		FACE	Approx. 0
		FOOT	Approx. 50
		FOOT/DEF.	Approx. 75
		DEF.	Approx. 100

## ACTUATOR TEST

Item No.	Actuator test item	Item No.	Actuator test item
01	Blower fan motor OFF command	08	Air outlet mode FACE drive
02	Blower fan motor LO drive	09	Air outlet mode FOOT drive
03	Blower fan motor ME drive	10	Air outlet mode DEF. drive
04	Blower fan motor HI drive	11	Magnet clutch OFF command
05	Air mix damper 0% drive	12	Magnet clutch ON command
06	Air mix damper 50% drive	13	Inside/outside air changeover FRESH drive
07	Air mix damper 100% drive	14	Inside/outside air changeover RECIRC drive



# Workshop Manual

electrical wiring

## FTO '98

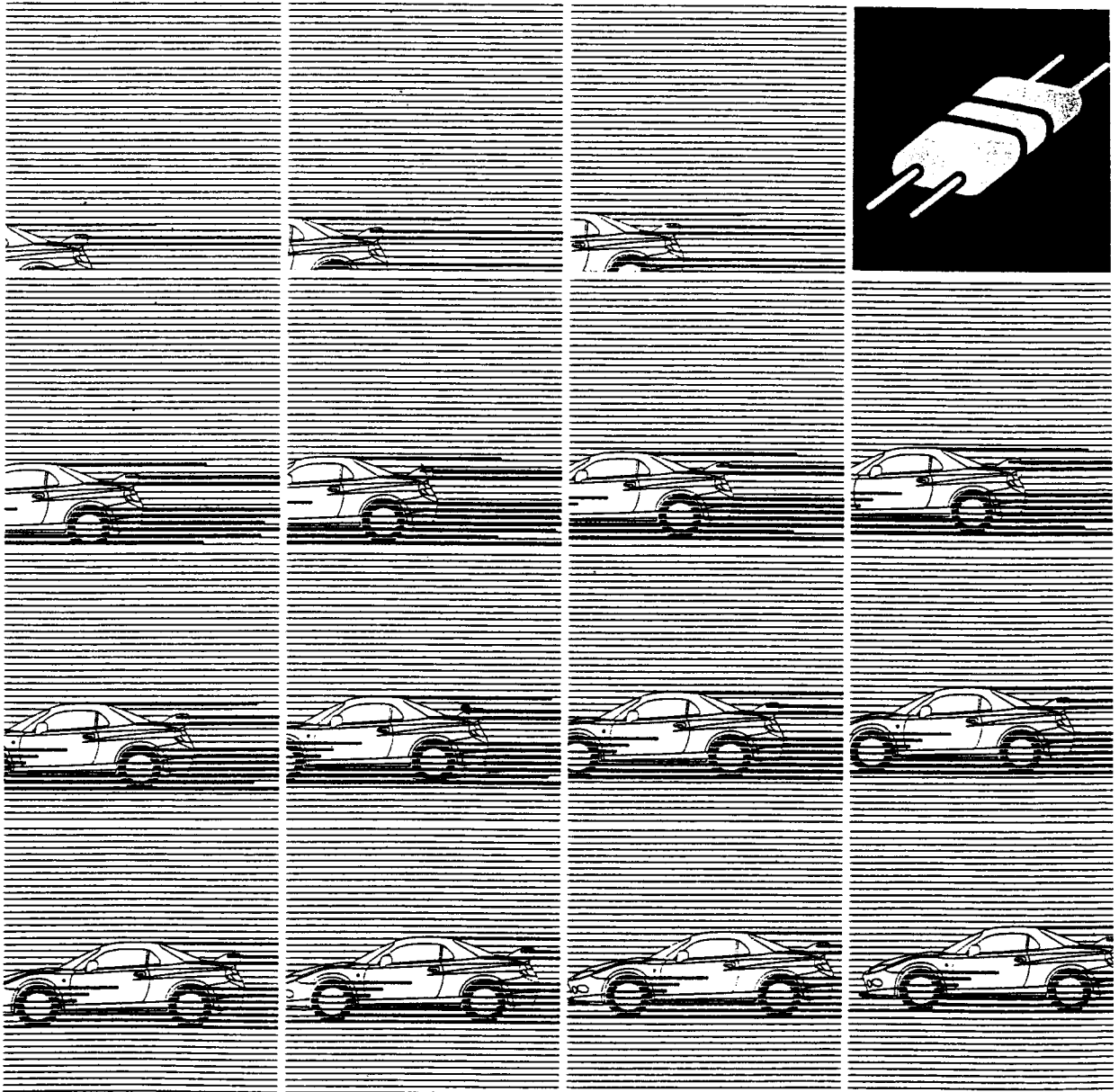

# FTO

## ELECTRICAL WIRING

### FOREWORD

This Electrical Wiring Manual contains information necessary for inspection and servicing of electrical wiring of Mitsubishi FTO edited in the form of wiring harness configuration diagrams and function-separated circuit diagrams.

It is recommended that all service mechanics engaged in the servicing of the vehicle refer to the following publications as well as this manual.

TECHNICAL INFORMATION MANUAL  
PYME9801

WORKSHOP MANUAL  
CHASSIS GROUP  
PWME9801

BODY REPAIR MANUAL  
PBME9801

ENGINE GROUP  
PWEE9801

PARTS CATALOGUE  
B806G208A

All information, illustrations and product descriptions contained in this manual are current as of time of publication. We, however, reserve the right to make changes at any time without prior notice or obligation.

## GROUP INDEX

HOW TO READ THE WIRING  
DIAGRAMS .....

1

WIRING HARNESS  
CONFIGURATION DIAGRAMS ...

2

SINGLE PART INSTALLATION  
POSITION .....

3

CIRCUIT DIAGRAM .....

4

INDEX .....





# **HOW TO USE THIS MANUAL**

## **CONTENTS**

The preceding page contains GROUP INDEX that lists the group title and group number.

## **PAGE NUMBERS**

All page numbers consist of two sets of digits separated by a dash. The digits preceding the dash identify the number of the group. The digits following the dash represent the consecutive page number within the group. The page number can be found on the top left or right of each page.

## **OPERATION AND TROUBLESHOOTING HINTS**

In the GROUP 4 circuit diagrams, the operation and troubleshooting hints are given on the previous page or following page for each circuit where necessary.

---

# HOW TO READ THE WIRING DIAGRAMS

## CONTENTS

MODELS .....	1-2	HOW TO READ CIRCUIT DIAGRAMS .....	1-4
COMPOSITION AND CONTENTS OF WIRING DIAGRAMS .....	1-2	MARKINGS FOR CONNECTOR EARTHING .....	1-6
HOW TO READ CONFIGURATION DIAGRAMS .....	1-3	WIRE COLOUR CODES .....	1-9
		ABBREVIATION SYMBOLS .....	1-10

---

**MODELS**

Model code		Engine model	Transmission model	Fuel supply system
DE3A	HNGHR	6A12 <V6-MIVEC> (1,998 $\text{cm}^3$ )	F5M42 (2WD-5M/T)	MPI
	HYGHR		F5A42 (2WD-5A/T)	

**COMPOSITION AND CONTENTS OF WIRING DIAGRAMS**

- (1) This manual consists of wiring harness diagrams, installation locations of individual parts, circuits diagrams and index.
- (2) In each section, all specifications are listed, including optional specifications. Accordingly, some specifications may not be applicable for individual vehicles.

Section	Basic contents
Wiring harness configuration diagrams	Connector locations and harness wiring configurations on actual vehicles are illustrated.
Single part installation position	Locations are shown for each point of relays, electronic control units, sensors, solenoids, solenoid valves, diodes, inspection connectors, spare connectors, fusible links, fuses, etc. In the part's lists, parts are listed in alphabetical order.
Circuit diagrams	<p>Circuits from power supply to earth are shown completely, classified according to system. There is a main division into power circuits, and circuits classified by system. The circuits classified by system also include operation and troubleshooting hints.</p> <ul style="list-style-type: none"> <li>■ Junction block The entire circuit for the junction block is described, because only the part of the junction block needed <i>is</i> normally shown in each circuit diagram.</li> <li>● Joint connectors The internal circuits for all joint connectors are described, because only the part needed is shown in each circuit diagram.</li> <li>● Power supply circuits Circuits from the battery to fusible link, dedicated fuses, ignition switch, general purpose fuses, etc.</li> <li>● Circuits classified by system For each system, the circuits are shown from fuse to earth, excluding the power supply sections.</li> <li>■ Operation The standard operation of each system is briefly described, following the route of current flow.</li> <li>● Troubleshooting hints This is a brief explanation of the inspection points that serve as hints when troubleshooting. Explanations of the circuits controlled by the electronic control unit are omitted. Refer to the related publications as required.</li> </ul>
Index	All components used are listed by connector number and component name.

## HOW TO READ CONFIGURATION DIAGRAMS

The wiring harness diagrams clearly show the connector locations and harness routings at each site on actual vehicles.

Denotes connector No.  
The same connector No. is used throughout the circuit diagrams to facilitate connector location searches.  
The first alphabetical symbol indicates the location site of the connector and a number that follows is the unique number. Numbers are assigned to parts in clockwise order on the diagram.

Example: A-12  
 A: Connector location site symbol  
 12: Number specific to connector (serial number)

A:  
 A: Engine compartment  
 B: Dash panel  
 C: Instrument panel  
 D: Floor and roof  
 E: Door  
 F: Luggage compartment

Denotes earth point.  
Same earth number is used throughout circuit diagrams to facilitate search of earth point. Refer to GROUP 3 SINGLE PART INSTALLATION POSITION – EARTH MOUNTING LOCATIONS for details of earth points.

Denotes a section covered by a corrugated tube.

The mark ★ shows the standard mounting position of wiring harness.

Indicates the device to which the connector is to be connected.

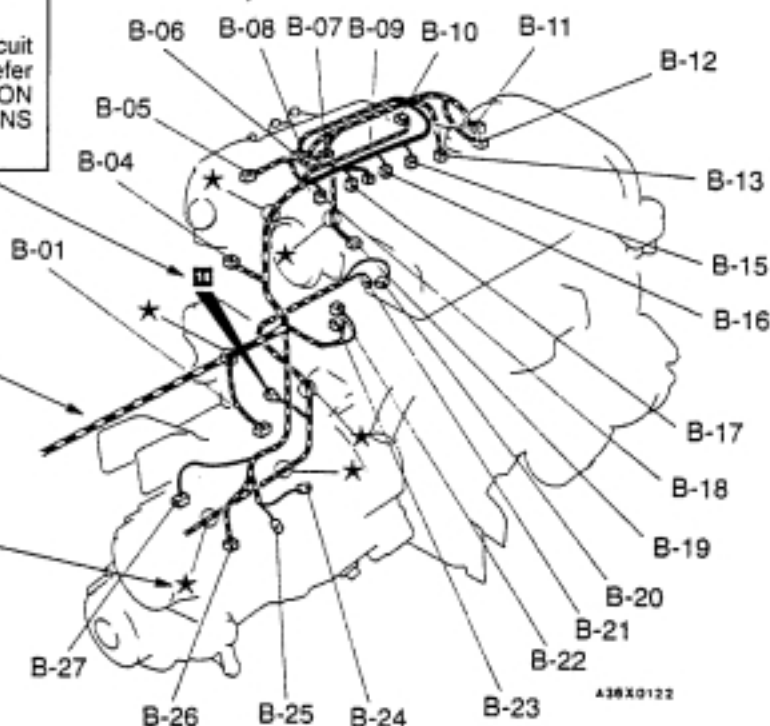

- |            |                          |             |                       |
|------------|--------------------------|-------------|-----------------------|
| B-01 (3-B) | Vehicle speed sensor     | B-16 (2-GR) | Injector No. 2        |
| B-02 (6)   | Distributor assembly     | B-17 (2-GR) | Injector No. 3        |
| B-03 (2)   | Distributor assembly     | B-18 (2-GR) | Injector No. 4        |
| B-04 (6-B) | Idle speed control servo | B-19 (4)    | Oxygen sensor (front) |
| B-05 (4-B) | Throttle position sensor | B-20 (1-BR) | Starter motor         |

The number of connector pins and the connector colour (except milk white)\* are shown for ease of retrieval.

\*: Typical connector colours

- B: Black
- Y: Yellow
- L: Blue
- G: Green
- R: Red
- BR: Brown
- V: Violet
- O: Orange
- GR: Gray

Example: (2-B)

(2-B)  
 B: Connector colour (milk white if no colour is indicated)  
 2: Number of connector pins

# HOW TO READ CIRCUIT DIAGRAMS

The circuit of each system from fuse (or fusible link) to earth is shown. The power supply is shown at the top and the earth at the bottom to facilitate understanding of the current flow.

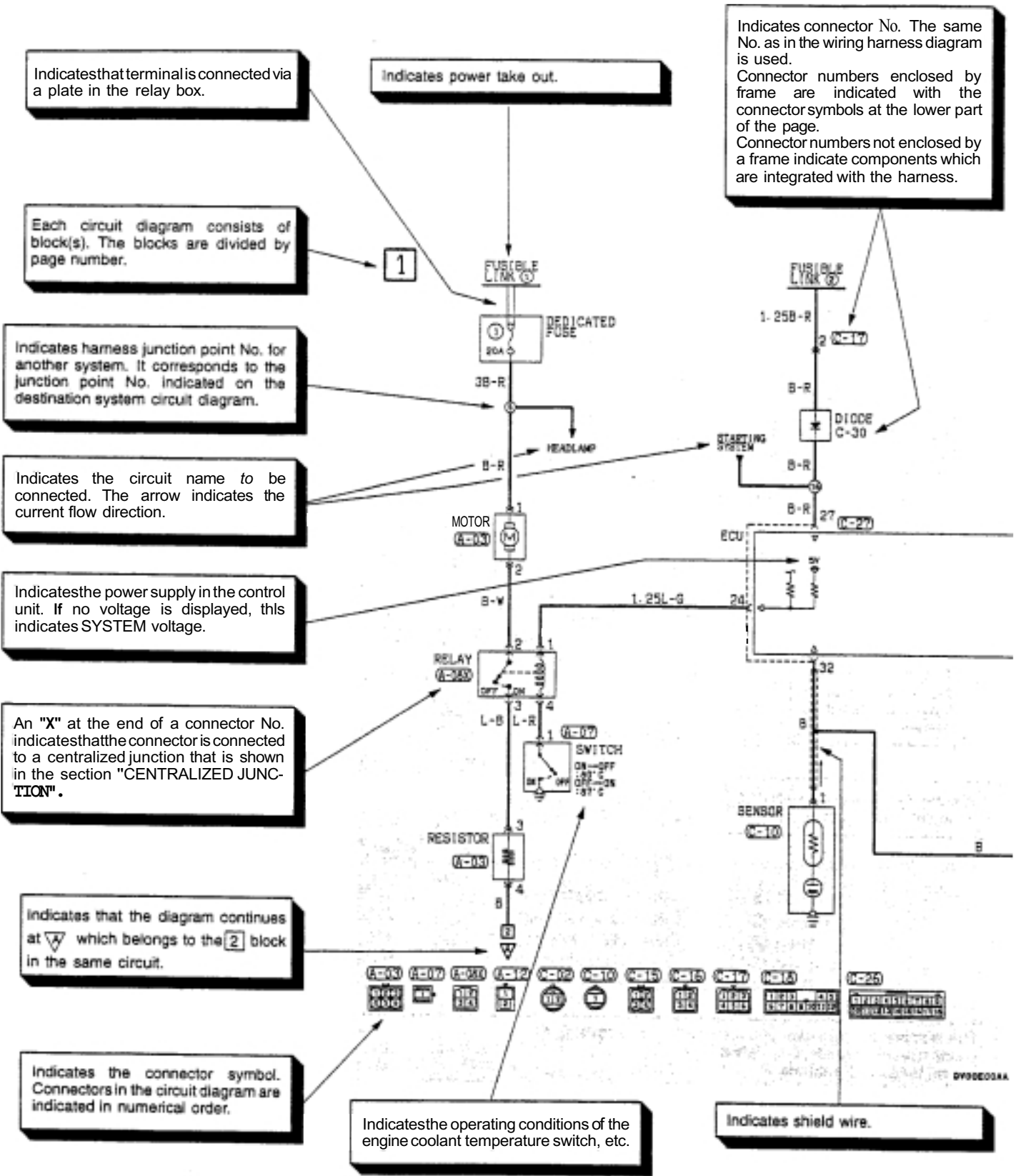

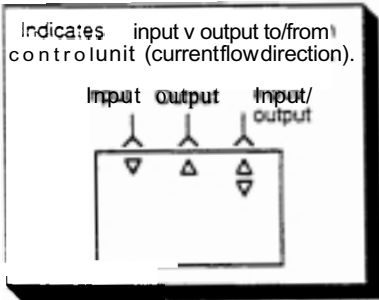



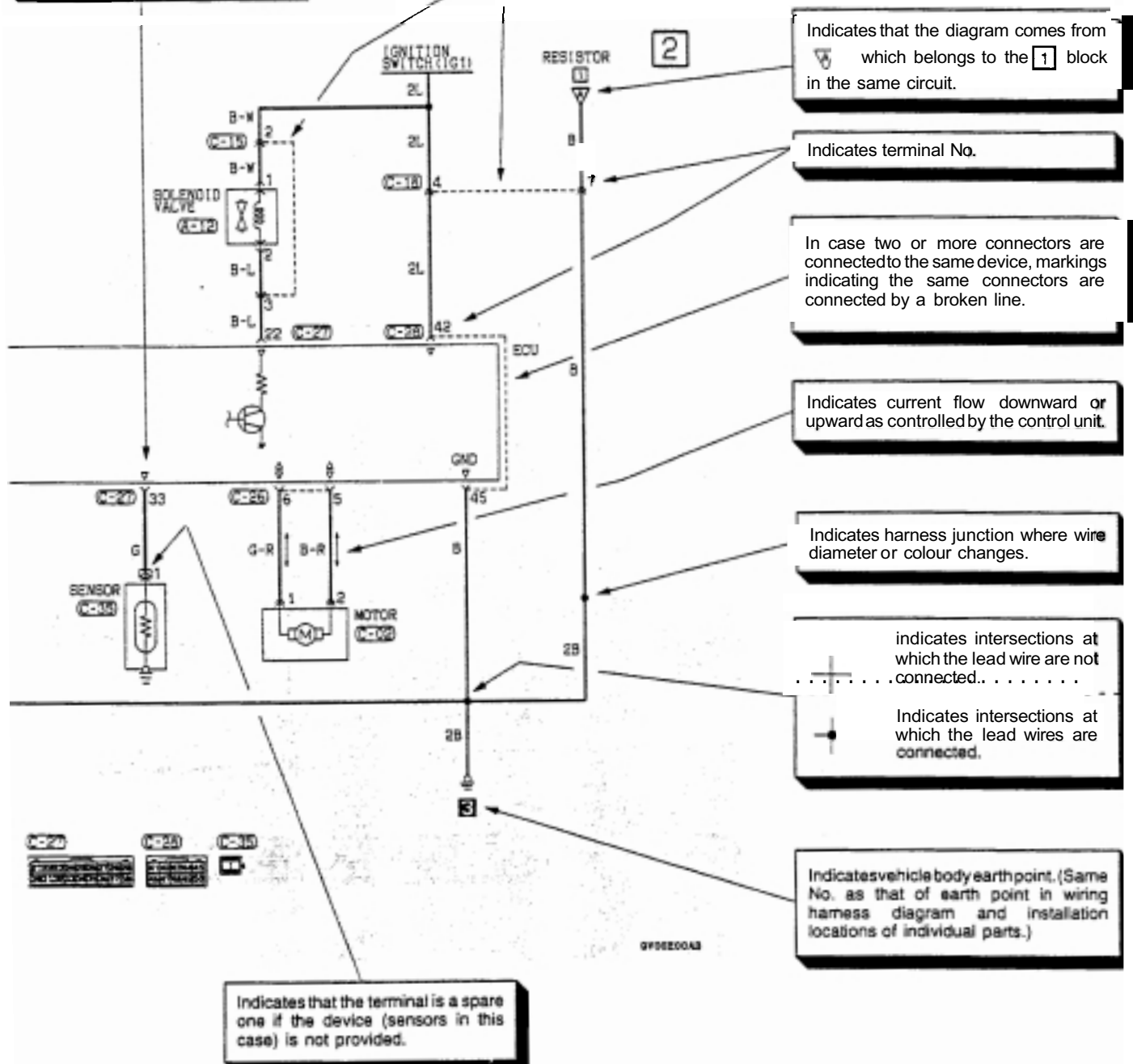



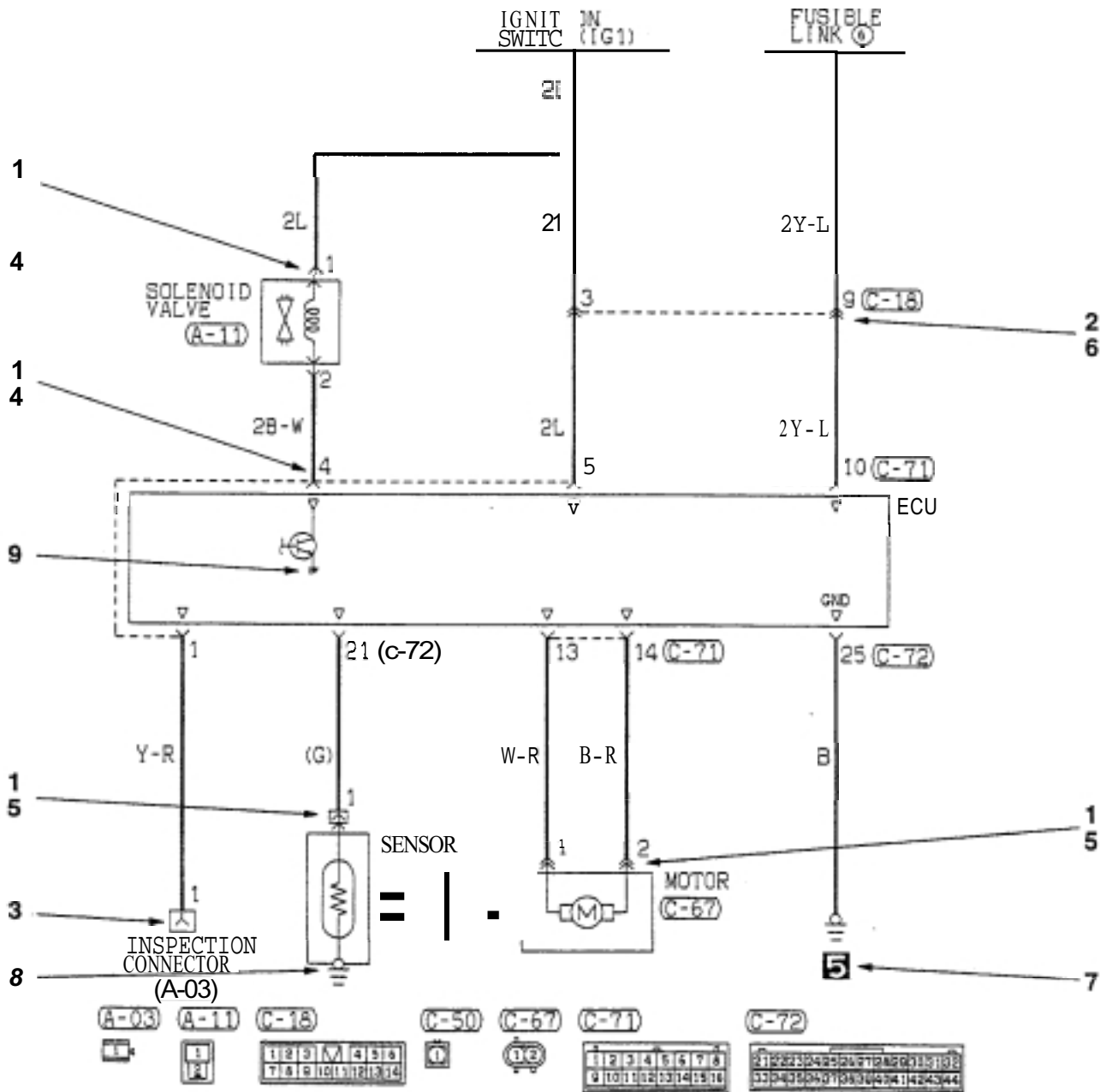

A broken line indicates that these connectors are the same intermediate connectors.

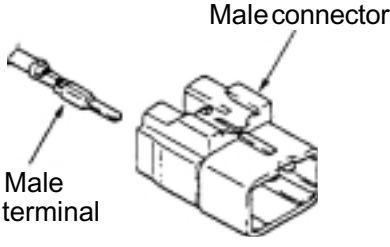

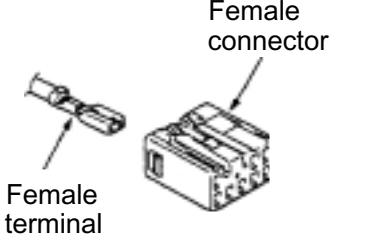

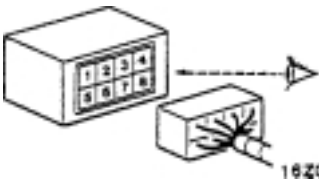

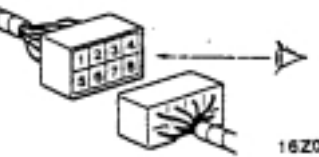



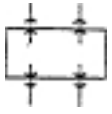

970820048

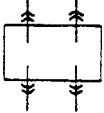
MARKINGS FOR CONNECTOR EARTHING

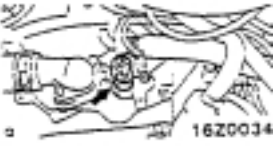

Item	No.	Connector/Earthing	Symbol	Contents
Connector and terminal marking	-		<p>Male terminal</p>  <p>1620021</p>	<p>The male and female terminals are indicated as shown. The connector with male terminal(s) is called as male connector and indicated by double connector contour lines, while the connector with female terminal(s) is called as female connector and indicated by single connector contour line.</p>
		<p>Male connector</p>  <p>1620016</p>		
		<p>Female terminal</p>  <p>1620022</p>		
	<p>Female connector</p>  <p>1620017</p>			
Connector symbol marking	1	<p>Device</p> 	 <p>1620016</p>	<p>The symbol indicates the vehicle connector as viewed from the illustrated direction. At the connection with a device, the connector symbol on the device side is shown, and for an intermediate connector, a male connector symbol is shown. For spare connectors and check connectors, no device is connected, and so the harness-side connector symbol is shown for these connectors. The details for the diagnosis connector differ from the above description. For details, refer to the "MUT-II operation instructions".</p>
	2	<p>Intermediate connector</p> 		
	3	<p>Spare connector, check connector</p> 		



Item	No.	Connector/Earthing	Symbol	Contents
Connector connection marking	4	Direct connection type  1620026	 1620023	A connection between a device and connector on the harness side is either by direct insertion in the device (direct connection type) or by connection with a harness connector on the device side furnished (harness connection type). The two types are indicated as illustrated.
	5	Harness connection type  1620027	 1620024	
	6	Intermediate connector  1620028	 1620025	
Earth markings	7	Body earth  1620033	 7620018	Earth is either by body earth, device earth or control unit interior earth. These are indicated as illustrated.
	8	Device earth  1620034	 1620019	
	9	Earth in control unit  1620032	 1620020	

## WIRE COLOUR CODES

Code	Wire colour	Code	Wire colour
B	Black	P	Pink
BR	Brown	R	Red
G	Green	SB	Sky blue
GR	Gray	SI	Silver
L	Blue	V	Violet
IG	Light green	W	White
O	Orange	Y	Yellow

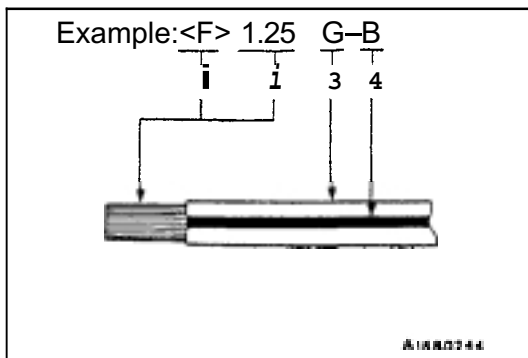

If a cable has two colours, the first of the two colour code characters indicates the basic colour (colour of the cable coating) and the second indicates the marking colour.

No.	Meaning
1	<F>:Flexible wire
	<T>:Twistedwire
2	Wire size(mm <sup>2</sup> )*
3	Basic colour (colour of the cable coating)
4	Marking colour

**NOTE**

\*: No code indicates 0.5 mm<sup>2</sup>.

Cable colour code in parentheses indicates 0.3 mm<sup>2</sup>.

## 1-10 HOW TO READ THE WIRING DIAGRAMS – Abbreviation Symbols

### ABBREVIATION SYMBOLS

The abbreviation symbols used in wiring diagrams are defined below.

#### 1. Abbreviation symbols used for wiring harness

Abbreviation symbol	Meaning	Abbreviation symbol	Meaning
A / C	Air conditioner	M/T	Manual transmission
A / T	Automatic transmission	MIVEC	Mitsubishi innovative valve timing and lift electronic control system
ABS	Anti-skid braking system	MPI	Muiti-point injection
DOHC	Double overhead camshaft	SRS	Supplemental restraint system
INVECS-III	Intelligent& innovative vehicles electronic control system	TCL	Traction control system

#### 2. Abbreviations symbols used for combination meters

Abbreviation symbol	Meaning	Abbreviation symbol	Meaning
ABS	ABS warning lamp	SPEED	Speedometer
BEAM	High beam indicator lamp	SRS	Supplemental restraint system warning lamp
BRAKE	Brake warning lamp	T/GA	Engine coolant temperature gauge
CHECK ENGINE	Check engine warning lamp	TACHO	Tachometer
CHG	Charging warning lamp	TCL	TCL indicator lamp
DOOR	Door-ajar warning lamp	TCL OFF	TCL-OFF indicator lamp
F/GA	Fueigauge	TURN (LH)	Turn signal indicator lamp
FUEL	Low fuel warning lamp	TURN(RH)	
OIL	Oil pressure warning lamp	VOLT	Voltmeter
SEAT BELT	Seat belt warning lamp	WASHER	Washer fluid level warning lamp

3. Abbreviation symbols used for switches and relays

Name of switches and relays	Abbreviation symbols	Operation	Name of switches and relays	Abbreviation symbols	Operation
A/T shift switch	STANDARD MODE	Shift changes occur automatically in D range	Power window switch	UP	Window glass closes
	SPORT	Manual shift changes between 1st and 4th are possible		DOWN	Window glass opens
A/T select switch	DOWN	Downshifting occurs one gear at a time		AUTO	Window glass is fully closed or opened
	UP			LOCK	Window glass except driver's side is fully closed or opened action
Ignition switch	ACC	When turned to the ACC (ACCESSORY) or ON position, the power circuit will start.	Blower switch	LO	Blower operates at low speed
	IG1	Even when at the ST (START) position, the power circuit will start.		ML	Blower operates at medium low speed
	IG2	When 'at the ST (START) position, the power circuit will not start functioning.		MH	Blower operates at medium high speed
intermittent wiper control switch		Pause time for intermittent operation lengthen		HI	Blower operates at high speed
Sunroof switch	CLOSE	Sunroof closes	Motor antenna switch		
	OPEN	Sunroof opens		HALF	The antenna moves out to the half-extended position.
Switch and relay	OFF	Switched off	Lighting switch	TAIL	Tail , clearance , license plate and illumination lamps on
	ON	Switched on		HEAD	Headlamps on
Turn-signal lamp switch	LH	LH turn-signal lamps ON	Remote-controlled mirror switch	LH	LH mirror operates
	RH	RH turn-signal lamps ON		RH	RH mirror operates
Dimmer passing switch	LO	Low beams ON	Rearwiper washer switch	INT	Wiper operates intermittently
	HI	High beams ON		R/WA	Washer operates
Door lock actuator	LOCK	Door locked	Wiper switch	LO	Wipers operate at low speed
	UN-LOCK	Door unlocked		HI	Wipers operate at high speed
				INT	Wipers operate intermittently

## 1-12 HOW TO READ THE WIRING DIAGRAMS – Abbreviation Symbols

---

Abbreviation symbols	Meaning	Abbreviation symbols	Meaning
ECU	Electronic control unit	J/B	Junction block
<b>GND</b>	Earth	J/C	Joint connector
ILL	Illumination lamp	LH	Left
IND	Indicator lamp	RH	Right



---

# WIRING HARNESS CONFIGURATION DIAGRAMS

## CONTENTS

OVERALL WIRING DIAGRAM .....	2-2	FLOOR AND ROOF .....	2-13
ENGINE COMPARTMENT .....	2-4	DOOR .....	2-14
DASH PANEL .....	2-8	LUGGAGE COMPARTMENT .....	2-15
INSTRUMENT PANEL .....	2-12		

---

OVERALL WIRING DIAGRAM

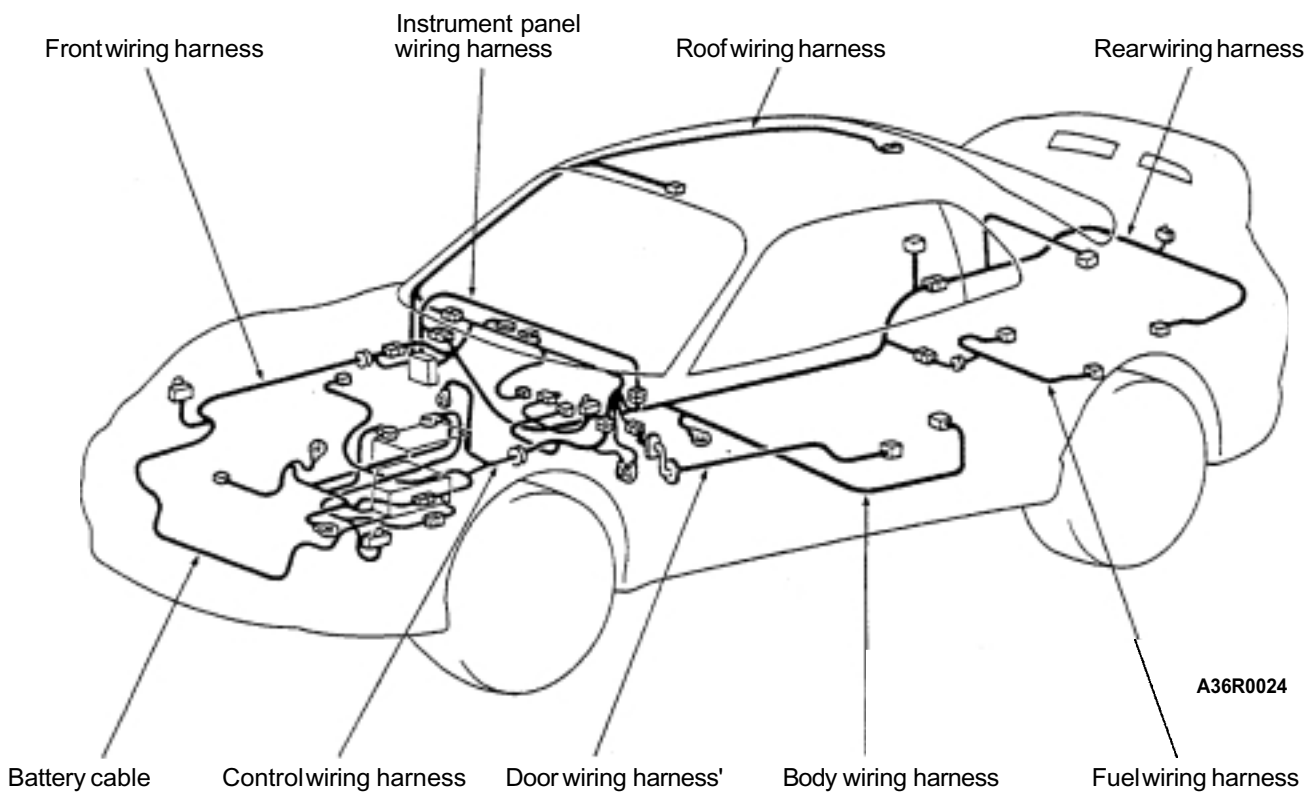

Remarks  
(1) This illustration shows only major wiring harnesses.  
(2) \*: also equipped at the right side.





## ENGINE COMPARTMENT

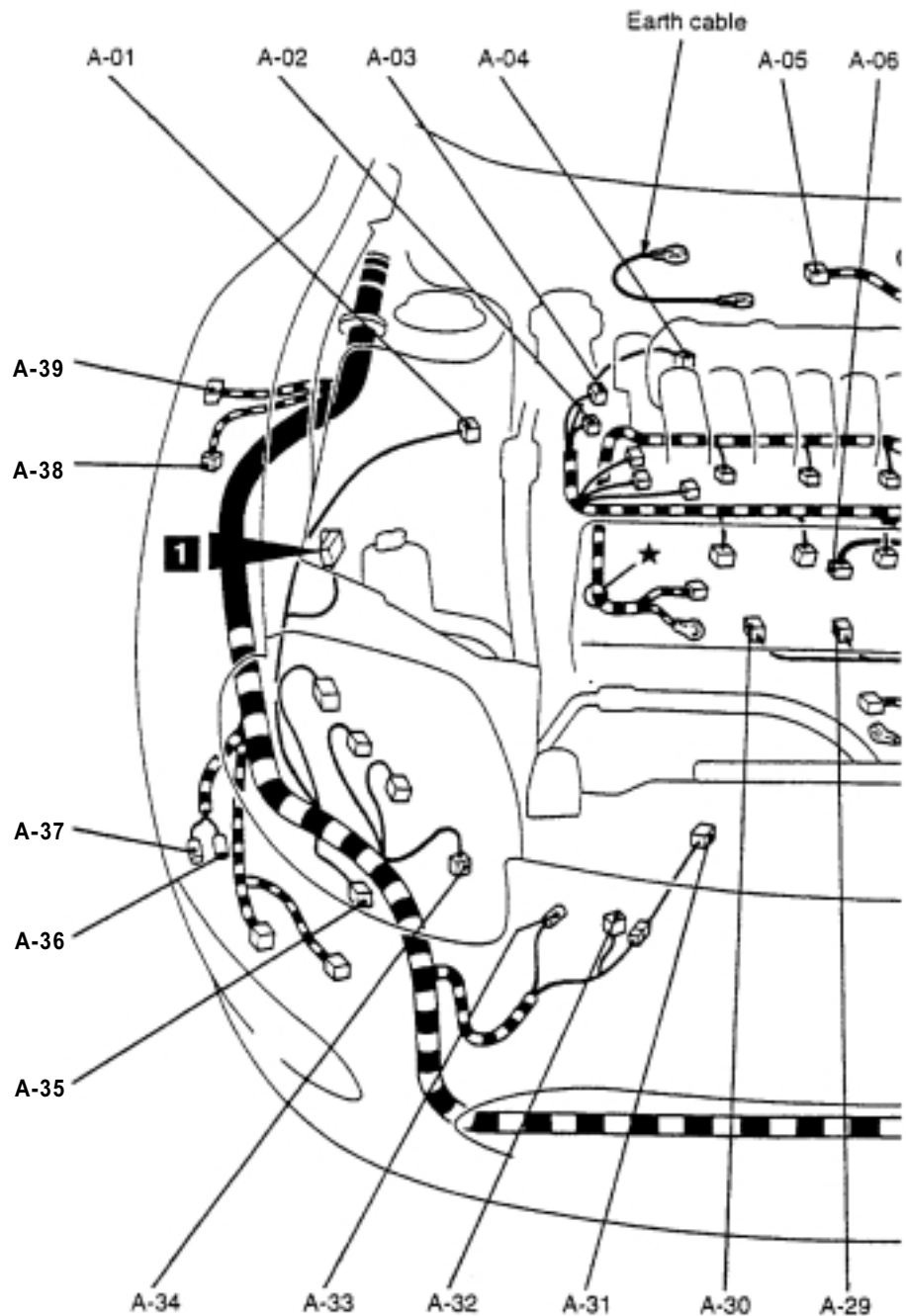
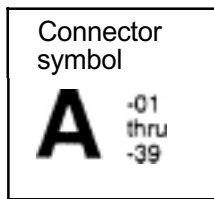

A-01 (2-B)	Brake fluid level sensor	A-12 (1-B)	Control wiring harness and battery cable combination
A-02 (4-B)	Variable induction control servo	A-13 (12-B)	Control wiring harness and front wiring harness combination
A-03 (2-B)	Variable induction control servo	A-14 (10-B)	Control wiring harness and front wiring harness combination <ABS>
A-04 (2-GR)	Intake air temperature sensor	A-15 (2-GR)	Side turn signal lamp (LH)
A-05 (3-B)	Atmospheric pressure sensor	A-16 (2-B)	Front speed sensor (LH) <ABS>
A-06 (3-B)	Vehicle speed sensor	A-17 (2-B)	Oil control valve (right bank side)
A-07 (4-B)	Throttle position sensor	A-18 (8-B)	Control wiring harness and injector wiring harness combination
A-08 (4-B)	Accelerator pedal position sensor	A-19 (2-GR)	Detonation sensor
A-09 (6-B)	Idle speed control servo		
A-10 (4-B)	Windshield wiper motor		
A-11 (2-BR)	Dual pressure switch		

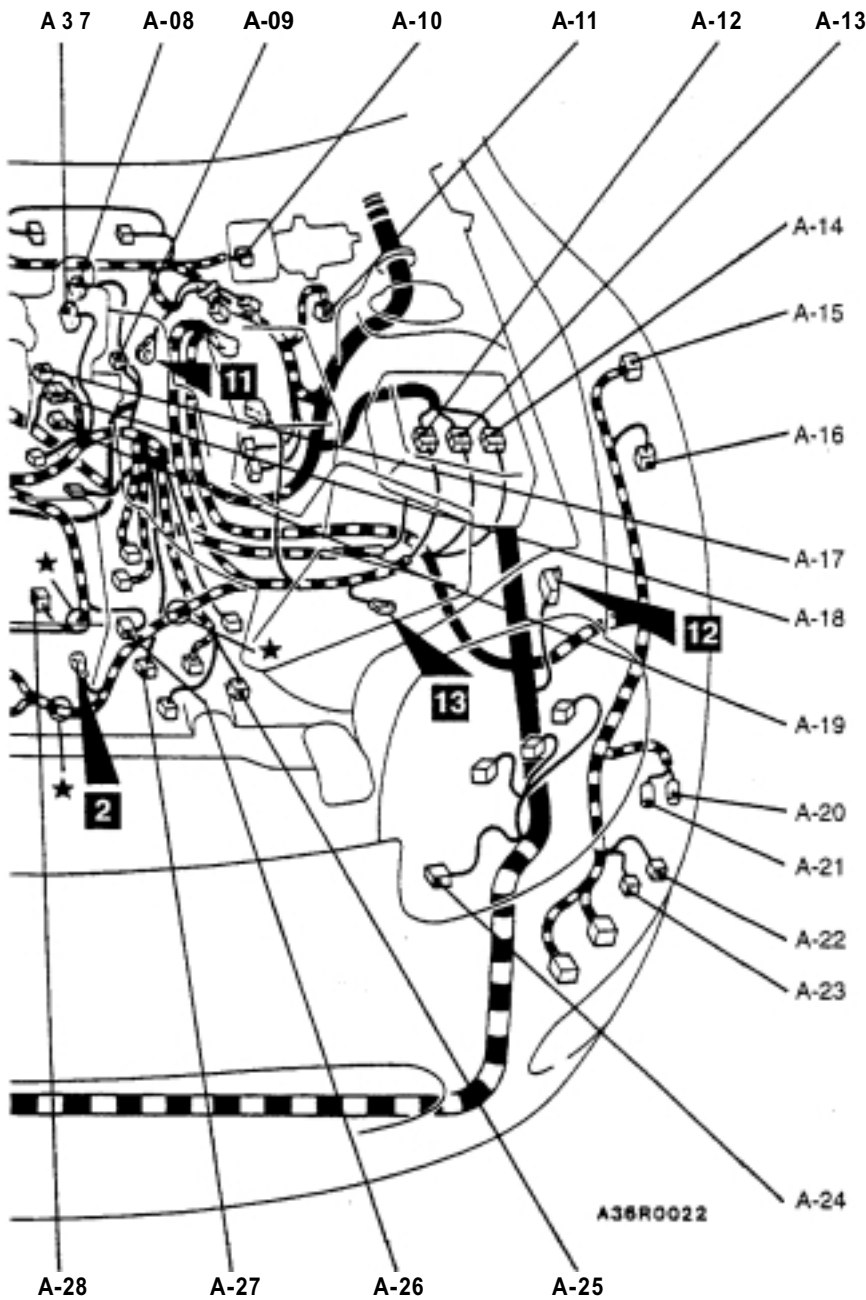

- |              |                                       |             |                                    |
|--------------|---------------------------------------|-------------|------------------------------------|
| A-20 (1)     | Horn (LO)                             | A-30 (3-GR) | Ignition coil B                    |
| A-21 (1)     | Horn (LO)                             | A-31 (1-B)  | Oil pressure switch                |
| A-22 (4-B)   | Windshield washer motor               | A-32 (1-8)  | A/C compressor assembly            |
| A-23 (2-B)   | Rear washer motor                     | A-33 (1)    | Power steering oil pressure switch |
| A-24 (2-B)   | Radiator fan motor                    | A-34 (2-B)  | Condenser fan motor                |
| A-25 (10-GR) | A/T control solenoid valve assembly   | A-35 (2-8)  | Outside thermo sensor <A/C>        |
| A-26 (1-B)   | Engine coolant temperature gauge unit | A-36 (1)    | Horn (HI)                          |
| A-27 (2-B)   | Back-up lamp switch <M/T>             | A-37 (1)    | Horn (HI)                          |
| A-28 (13-GR) | Ignition coil C                       | A-38 (2-B)  | Front speed sensor (RH) <ABS>      |
| A-29 (3 4 3) | Ignition coil A                       | A-39 (2-GR) | Side turn signal lamp (RH)         |

## ENGINE COMPARTMENT

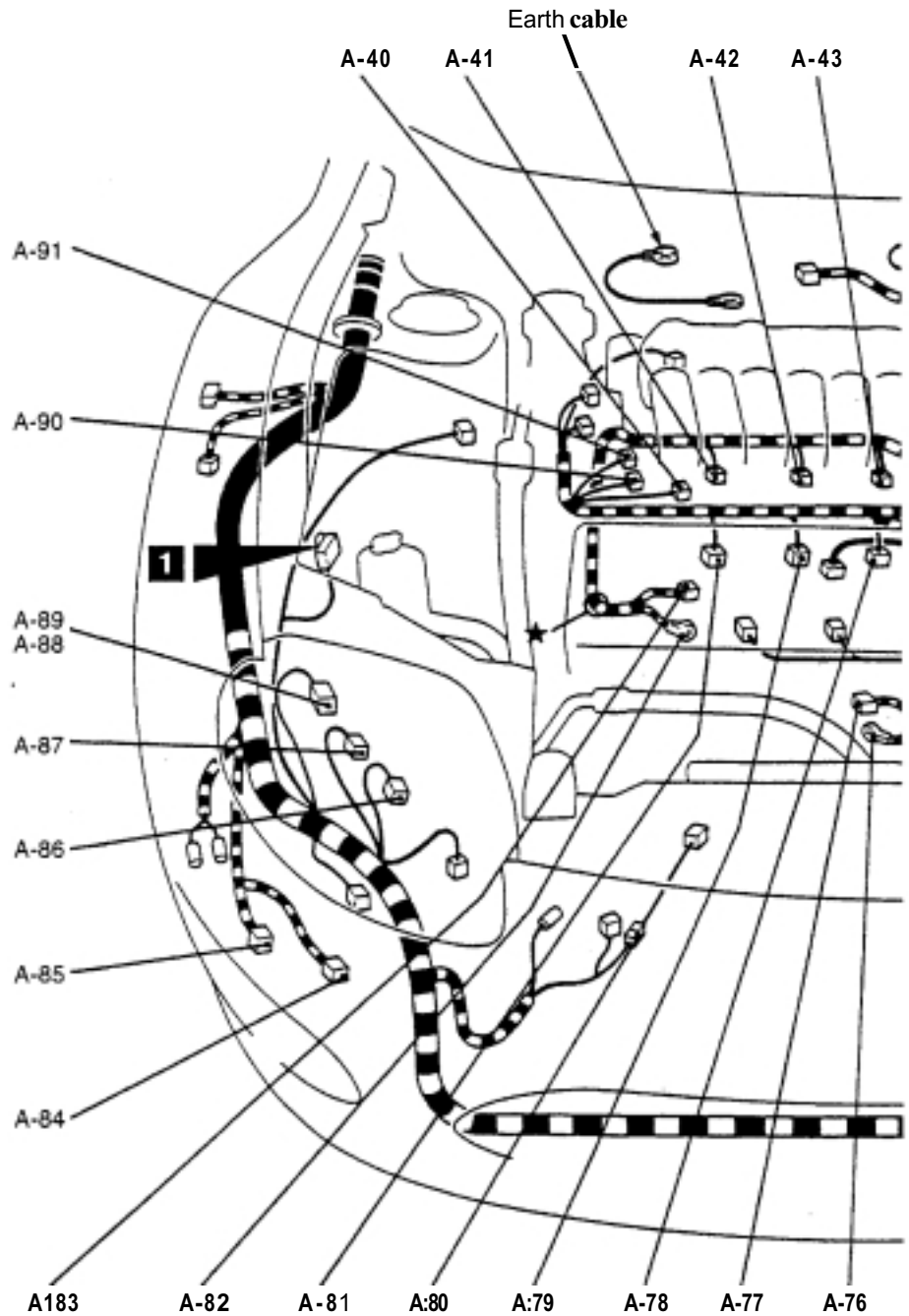
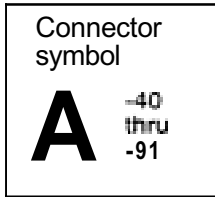

<b>A-40 (2-B)</b>	Oil control valve (left bank side)	<b>A-54X (5)</b>	Headlamp relay
<b>A-41 (2-GR)</b>	Injector No.1	<b>A-55X (5)</b>	A/C compressor relay
<b>A-42 (2-GR)</b>	Injector No.3	<b>A-56X (5)</b>	Condenser fan relay
<b>A-43 (2-GR)</b>	Injector No.5	<b>A-57X (5)</b>	Radiator fan relay
<b>A-44 (2-B)</b>	Vacuum solenoid valve <TCL>	<b>A-58X (5)</b>	Horn relay
<b>A-45 (1)</b>	Capacitor	<b>A-59X (4)</b>	Alternator relay
<b>A-46 (2-6)</b>	Ventilation solenoid valve <TCL>	<b>A-60X (5)</b>	Power window relay
<b>A-47 (1)</b>	Capacitor	<b>A-61X (5)</b>	Headlamp relay <vehicles> with discharge type headlamp>
<b>A-48 (1)</b>	Engine speed detection connector	<b>A-62X (5)</b>	No connection
<b>A-50 (8-B)</b>	Hydraulic unit <ABS>	<b>A-63X (5)</b>	No connection
<b>A-51 (2-6)</b>	Hydraulic unit <ABS>	<b>A-64X (5)</b>	No connection
<b>A-52X (5)</b>	ABS valve relay	<b>A-65 (4-B)</b>	Ignition failure sensor
<b>A-53X (5)</b>	ABS motor relay		

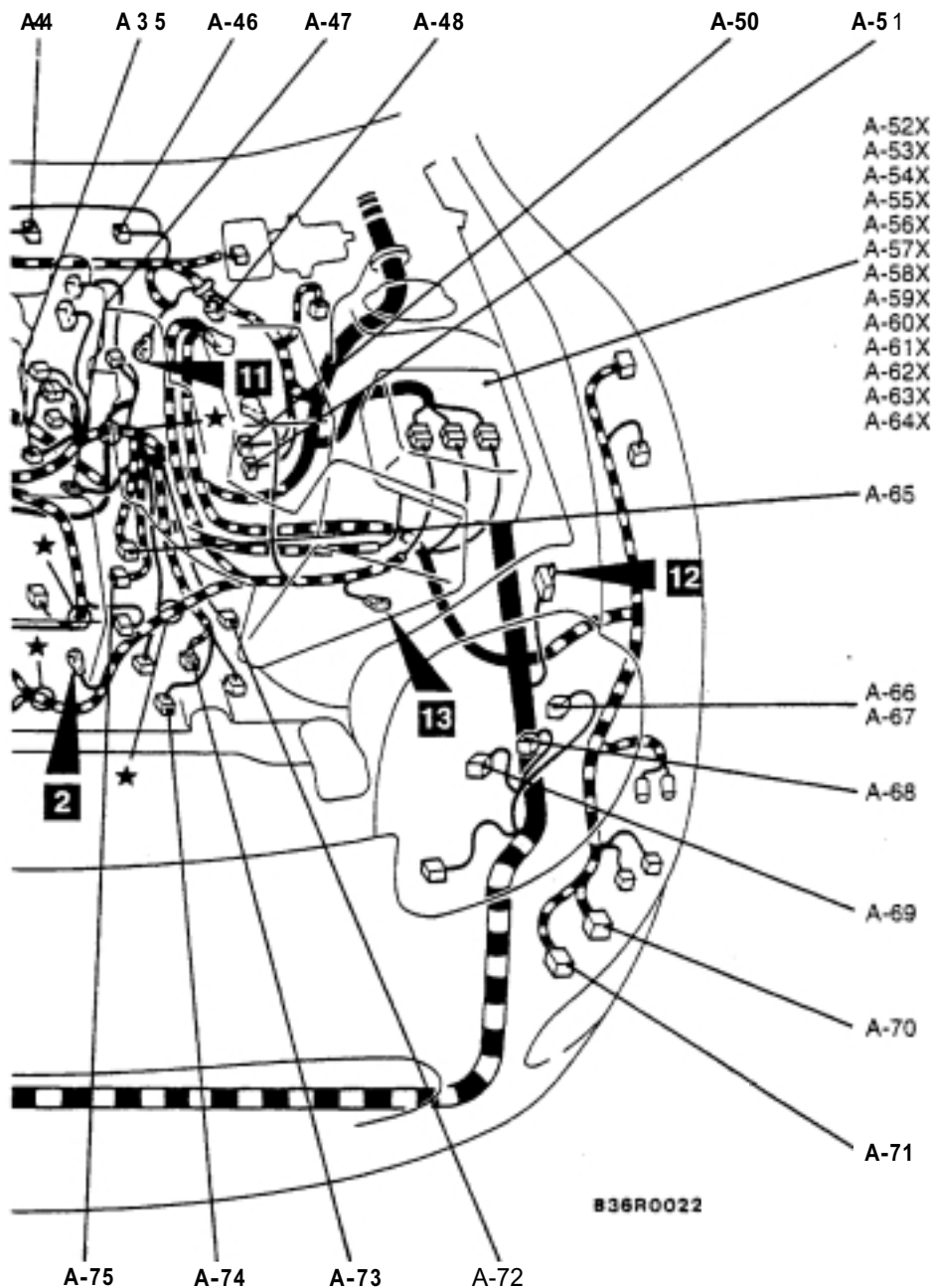

Connector colour code  
 B :Black  
 BR :Brown  
 G :Green  
 GR :Gray  
 L :Blue  
 V :Violet  
 SB :Sky blue  
 LG :Light green  
 O :Orange  
 P :Pink  
 R :Red  
 Y :Yellow  
 W :White

- A-66 (4-B) Headlamp (LH) <discharge type>
- A-67 (2-B) Headlamp (LH) <except discharge type>
- A-68 (2-GR) Position lamp (LH) <vehicles without discharge type headlamp>
- A-69 (2-B) Headlamp (LH)
- A-70 (2-GR) Front turn signal lamp (LH)
- A-71 (2-6) Fog lamp (LH)
- A-72 (2-GR) Output shaft speed sensor <A/T>
- A-73 (3-B) Input shaft speed sensor <A/T>
- A-74 (10-B) Inhibitor switch <A/T>
- A-75 (2-B) Engine coolant temperature sensor
- A-76 (1) Starter
- A-77 (1-B) Starter
- A-78 (2-GR) Injector No.6
- A-79 (2-GR) Injector No.4

- A-80 (1-B) Front wiring harness and oil pressure wiring harness combination
- A-81 (2-GR) Injector No.2
- A-82 (1) Alternator
- A-83 (4-GR) Alternator
- A-84 (2-B) Fog lamp (RH)
- A-85 (2-GR) Front turn signal lamp (RH)
- A-86 (2-B) Headlamp (RH)
- A-87 (2-GR) Position lamp (RH) <vehicles without discharge type headlamp>
- A-88 (2-B) Headlamp (RH) <except discharge type>
- A-89 (4-B) Headlamp (RH) <discharge type>
- A-90 (3-GR) Camshaft position sensor
- A-91 (3-B) Crank angle sensor

## DASH PANEL

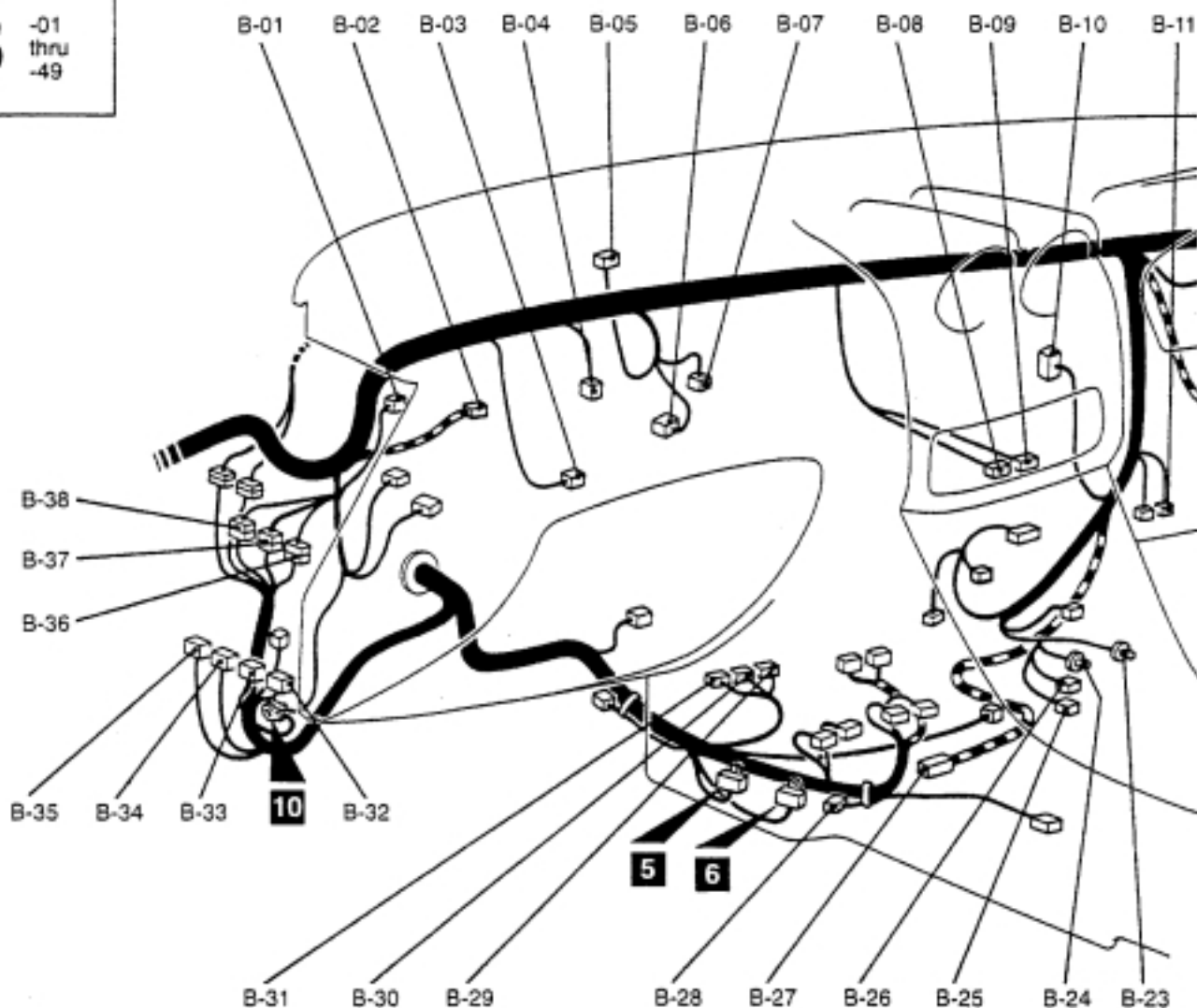
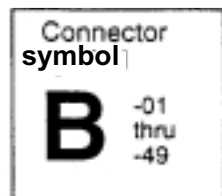

B-01 (2)	Outside/inside air selection damper control motor <A/C>	B-15 (6)	Body wiring harness and roof wiring harness combination
B-02 (2-R)	Air bag module (LH)	B-16 (4)	Front wiring harness and body wiring harness combination
8-03 (4-B)	Power transistor <A/C>	8-17 (18)	Front wiring harness and body wiring harness combination
8-04 (2)	Air thermo sensor <A/C>	B-18 (4)	J/C (5)
8-05 (2)	Photo sensor <A/C>	B-19 (22)	Body wiring harness and instrument panel wiring harness combination
B-06 (6)	Air mixing damper control motor and potentiometer <A/C>	8-20 (14)	Body wiring harness and instrument panel wiring harness combination
B-07 (2)	Heater water temperature sensor	8-21 (3)	Turn-signal and hazard warning flasher unit
8-08 (16-B)	NC-ECU	B-22 (2)	Stop lamp switch
B-09 (20-B)	NC-ECU	8-23 (2)	Ashtray illumination lamp
B-10 (6)	Mode selection damper control motor and potentiometer <A/C>	B-24 (2)	Cigarette lighter illumination lamp
B-11 (16-B)	Diagnosis connector	8-25 (1-B)	Cigarette lighter
8-12 (8)	Door lock-ECU		
B-13 (33)	JIC (2)		
B-14 (33)	JIC (3)		

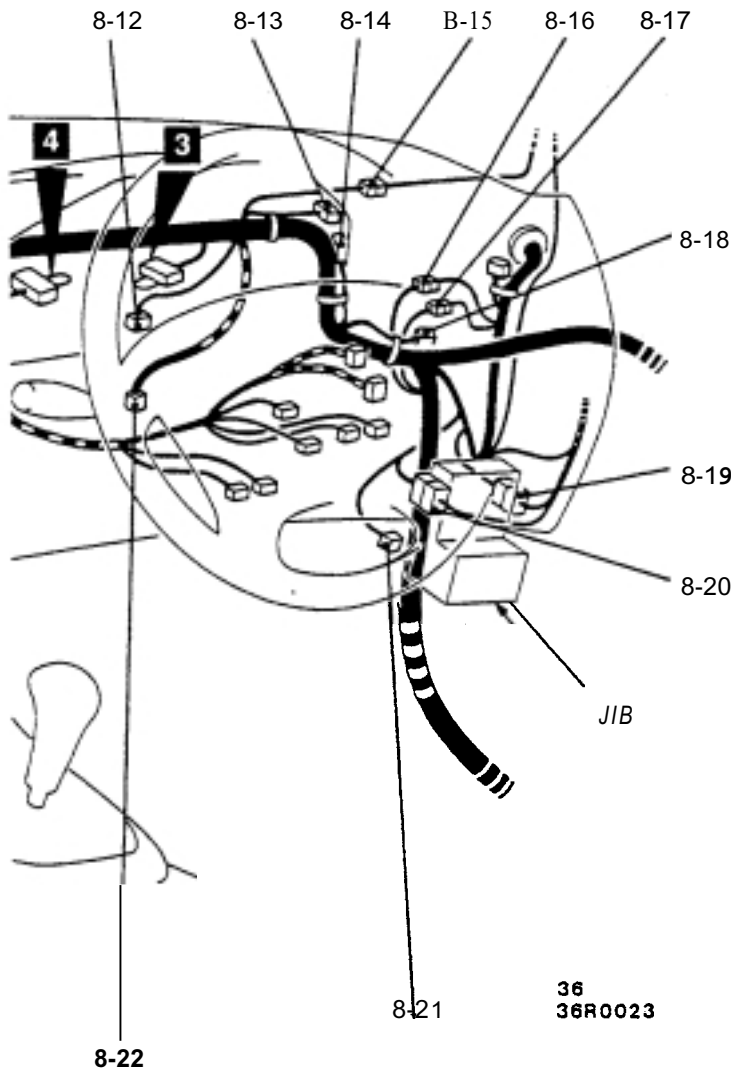

36  
36R0023

Junction block  
(Front side)

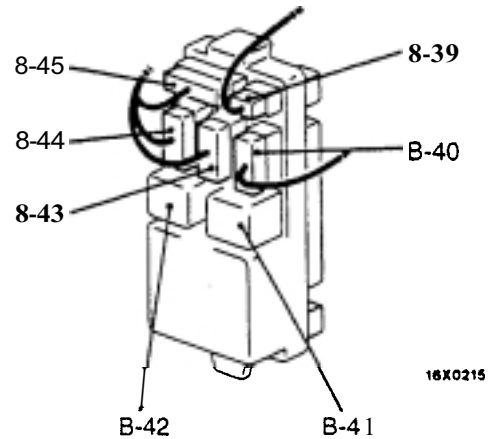

16X0215

(Rear side)

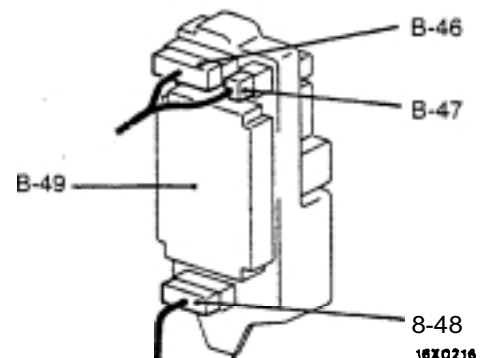

16X0216

00008 423

Connector colour code

B :Black	LG :Light green
BR :Brown	O :Orange
G :Green	P :Pink
GR :Gray	R :Red
L :Blue	Y :Yellow
V :Violet	W :White
SB :Sky blue	

8-26 (1)	Cigarette lighter
8-27 (22-Y)	SRS-ECU
8-28 (2-8)	Diode (for ABS circuit)
8-29 (22-L)	PJT-ECU
8-30 (16-L)	A/T-ECU
B-31 (26-L)	A/T-ECU
5 3 2 (26-G)	Engine-ECU
8-33 (16-G)	Engine-ECU
B-34 (12-G)	Engine-ECU
B-35 (22-G)	Engine-ECU
8-36 (18)	Body wiring harness and control wiring harness combination
B-37 (20)	Body wiring harness and control wiring harness combination <ABS>

8-38 (8)	Body wiring harness and control wiring harness combination <A/T>
B-39 (4-B)	J/B and roof wiring harness
8-40 (22-8)	J/B and instrument panel wiring harness combination
8-41 (5-B)	Blower relay
8-42 (5-B)	Defogger relay
8-43 (20-8)	J/B and body wiring harness
8-44 (10-B)	J/B and body wiring harness
B-45 (18-8)	J/B and body wiring harness
8-46 (18-B)	J/B and front wiring harness
8-47 (1-B)	J/B and front wiring harness
8-48 (19-B)	J/B and body wiring harness
8-49 (20-B)	Buzzer-ECU

DASH PANEL

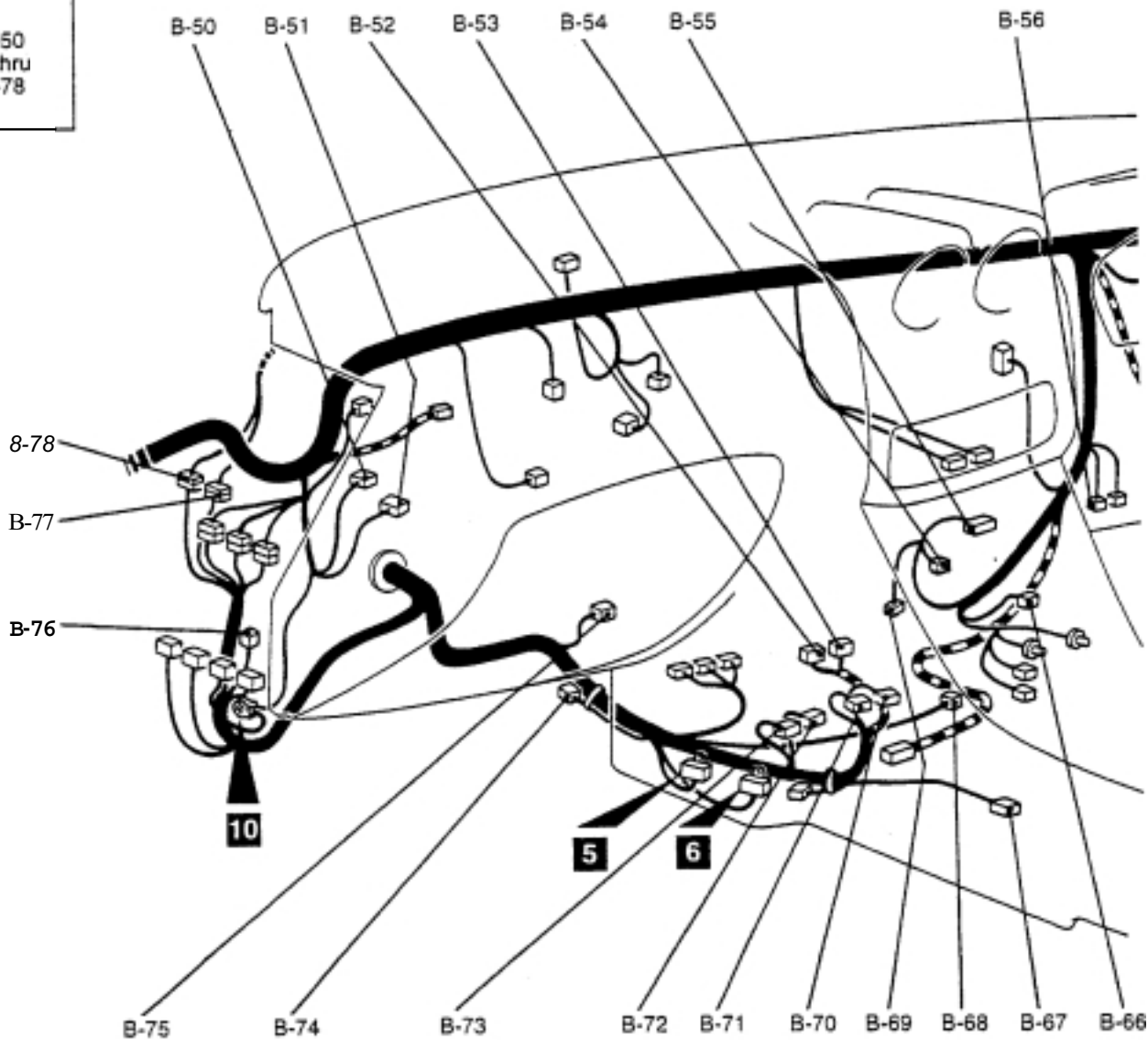
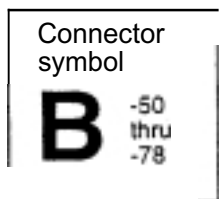

- 8-50 (2) Blower motor
- 8-51 (4-B) Blower high speed relay
- 8-52 (26) ABS-ECU
- 8-53 (16) ABS-ECU
- 8-54 (1) No connection
- 8-55 (14) Radio
- 8-56 (12) Diagnosis connector
- 8-57 (12) Column switch

- 8-58 (5) Steering wheel sensor <TCL>
- B-59 (10) Column switch
- 8-60 (6) Column switch
- 8-61 (22) J/C (6)
- 8-62 (6) Ignition-switch
- 8-63 (5-B) Key reminder switch
- 8-64 (3) Clock spring <SRS>
- 9-65 (2-R) Clock spring <SRS >

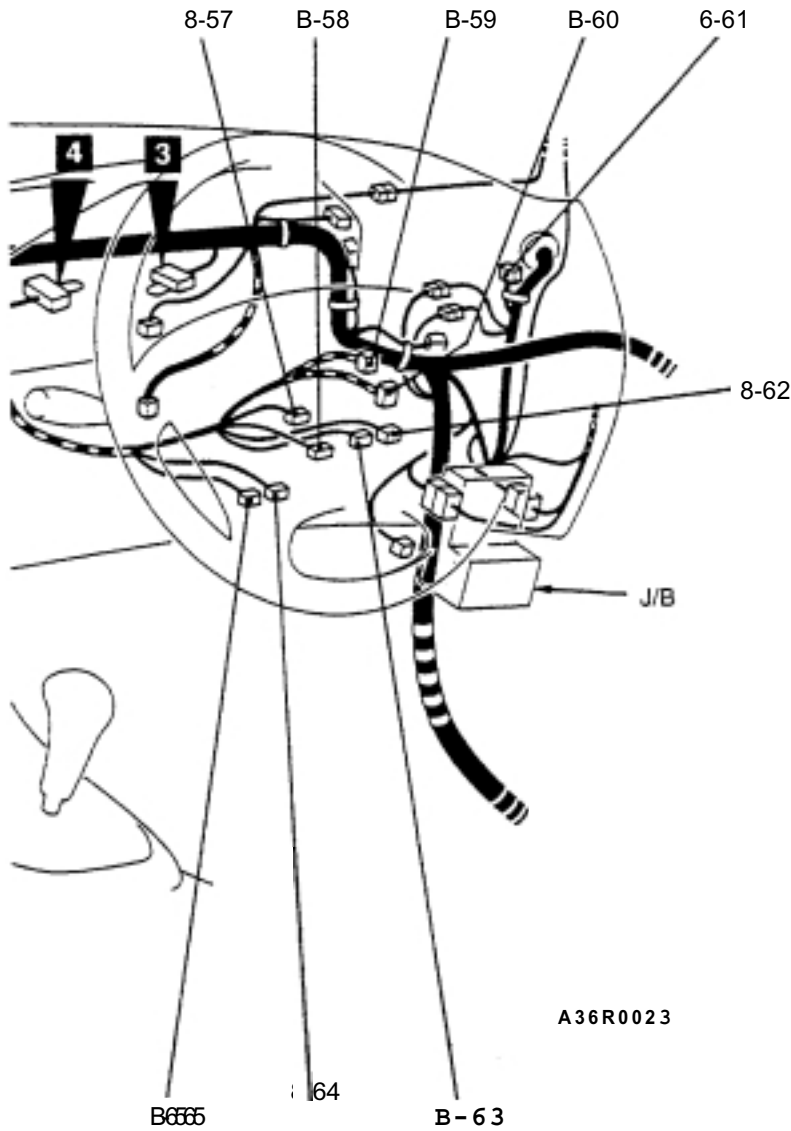

Connector colour code  
 B :Black  
 BR :Brown  
 G :Green  
 GR :Gray  
 L :Blue  
 V :Violet  
 SB :Sky blue  
 LG :Light green  
 O :Orange  
 P :Pink  
 R :Red  
 Y :Yellow  
 W :White

B-56 (2) Diagnosis code erasure connector  
 B-57 (8) Shift switch assembly <A/T>  
 B-58 (4) Oxygen sensor  
 B-59 (3-B) No connection  
 B-70 (16-B) TCL-ECU  
 B-71 (26-B) TCL-ECU  
 B-72 (4) Engine control relay  
 B-73 (4) Fuel pump relay

8-74 (2-B) Diode (for ABS circuit)  
 8-75 (4) A/T control relay  
 8-76 (22) JIC (1)  
 8-77 (18-8) Control wiring harness and instrument panel wiring harness combination  
 8-78 (10-B) Control wiring harness and instrument panel wiring harness combination



INSTRUMENT PANEL

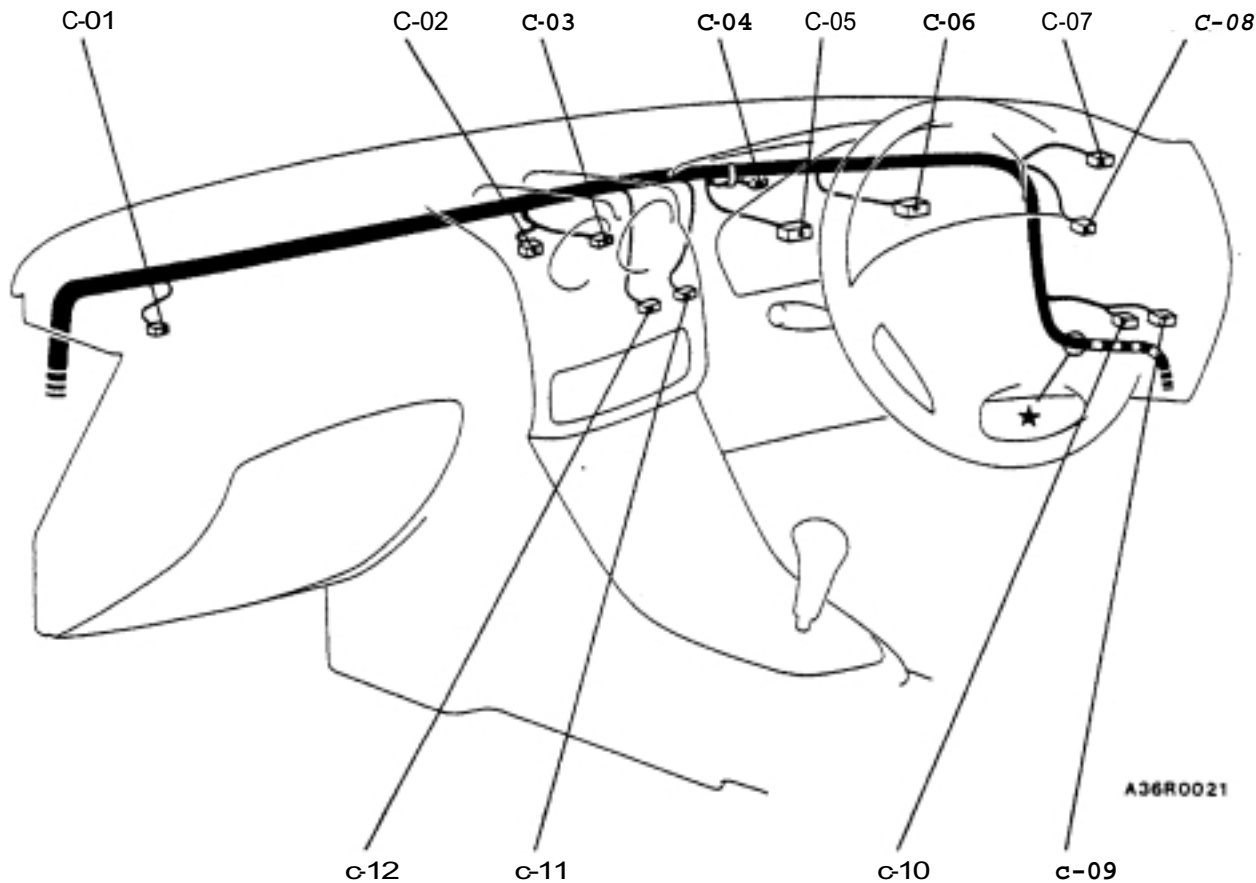
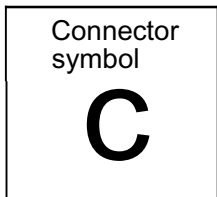

Connector colour code

- |              |                 |
|--------------|-----------------|
| B :Black     | LG :Light green |
| BR :Brown    | O :Orange       |
| G :Green     | P :Pink         |
| GR :Gray     | R :Red          |
| L :Blue      | Y :Yellow       |
| V :Violet    | W :White        |
| SB :Sky blue |                 |

- C-01 (2-B) Instrument panel speaker (**LH**)
- c-02 (**4**) Clock
- C-03 (6) Voltmeter
- C-04 (33) J/C (4)
- C-05 (25) Combination meter
- C-06 (**25**) Combination meter

- C-07 (2-B) Instrument panel speaker (RH)
- C-08 (6) Fog lamp switch
- C-09 (16-9) Remote controlled mirror switch
- C-10 (6) TCL switch
- C-11 (10-B) Motor antenna switch
- C-12 (10) Hazard warning switch

FLOOR AND ROOF

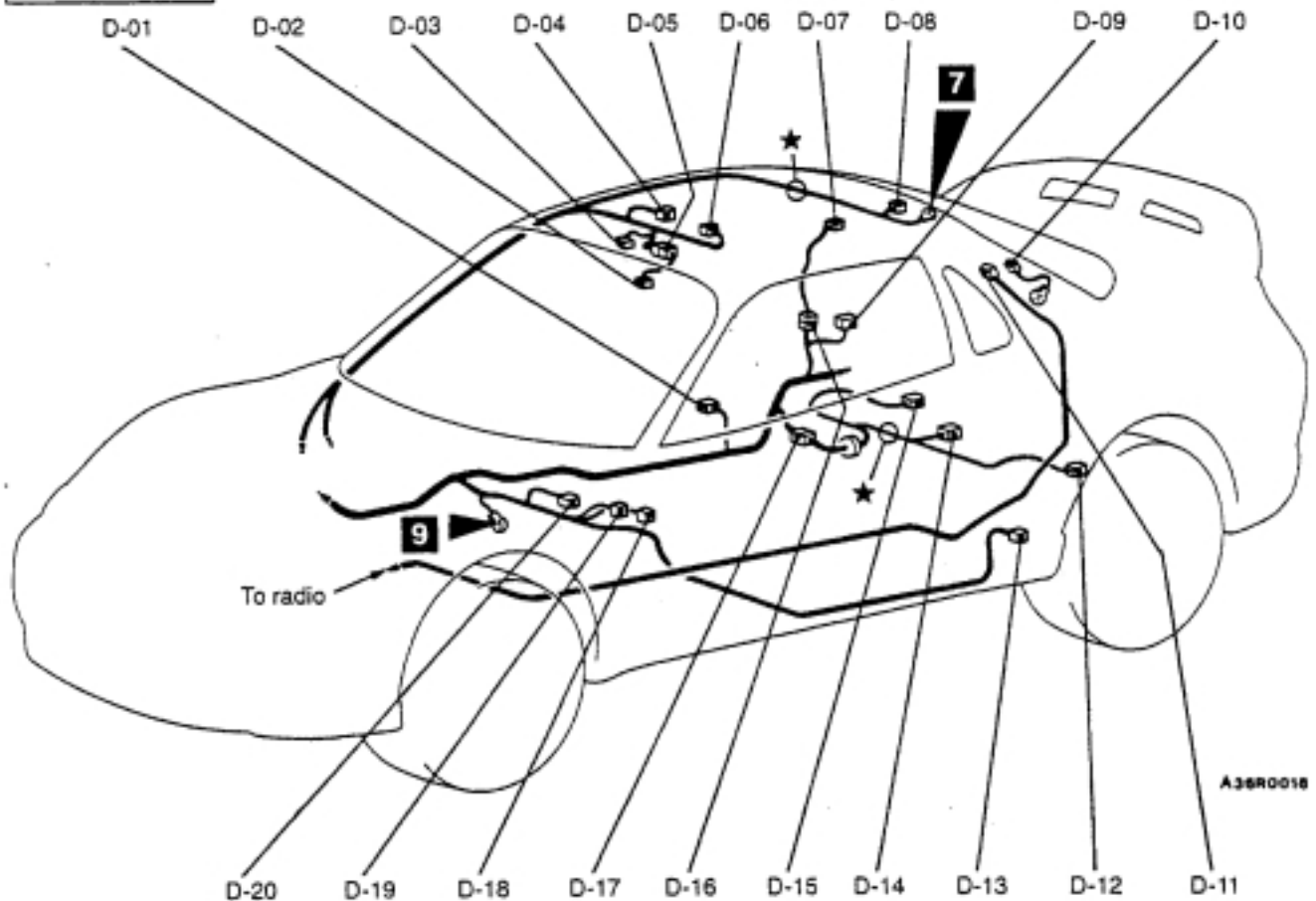
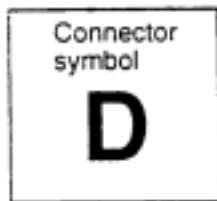

Connector colour code

B :Black	LG :Light green
BR :Brown	O :Orange
G :Green	P :Pink
GR :Gray	R :Red
L :Blue	Y :Yellow
V :Violet	W :White
SB :Sky blue	

D-01 (2-B)	Door switch (RH)	D-12 (2-B)	Rear speed sensor (LH) <ABS>
D-02 (4)	Map lamp	D-13 (1-B)	Door switch (LH)
D-03 (3-B)	Sunroof switch	D-14 (6)	Fuel pump assembly
D-04 (10)	Sunroof ECU	D-15 (2-B)	Rear speed sensor (RH) <ABS>
D-05 (3)	Roof wiring harness and map lamp sub wiring harness combination	D-16 (3)	Body wiring harness and defogger cable combination
D-06 (2)	Sunroof motor	D-17 (8)	Body wiring harness and fuel wiring harness combination
D-07 (1)	Defogger (+)	D-18 (1)	Parking brake switch
D-08 (2)	High-mounted stop lamp	D-19 (2)	Seat belt switch
D-09 (20)	Keyless entry receiver-ECU	D-20 (2)	No connection
D-10 (1)	Defogger (-)		
D-11 (1-B)	Glass antenna		

DOOR

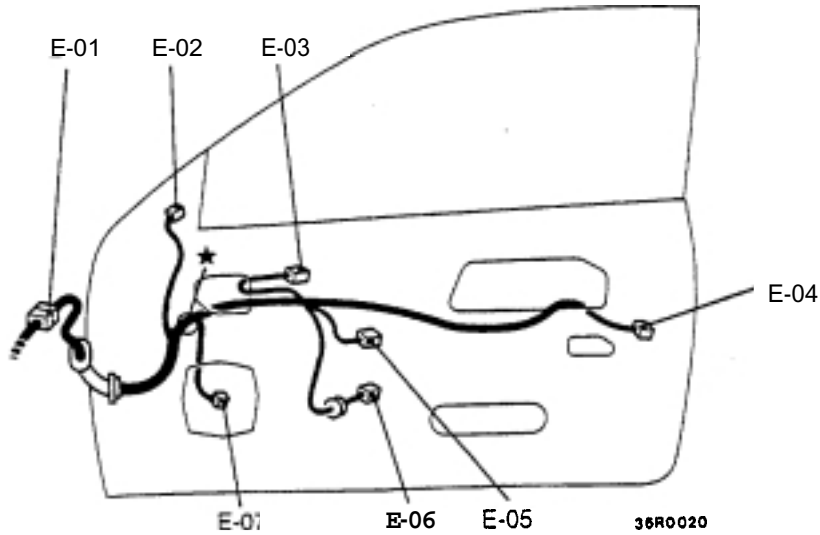
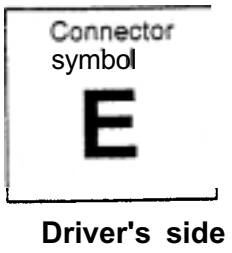

Passenger's side

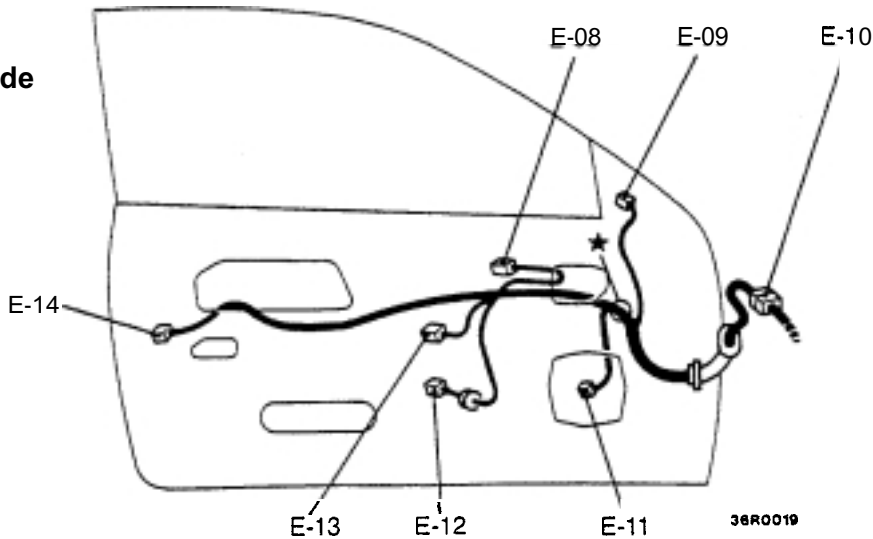

- Connector colour code
- B :Black
  - BR :Brown
  - G :Green
  - GR :Gray
  - I :Blue
  - V :Violet
  - SB :Sky blue
  - LG :Light green
  - O :Orange
  - P :Pink
  - R :Red
  - Y :Yellow
  - W :White

00008424

<b>E-01 (32)</b>	Body wiring harness and door wiring harness (RH) combination	<b>E-08 (8)</b>	Powerwindow sub switch
<b>E-02 (7)</b>	Remote controlled mirror (RH)	<b>E-09 (7)</b>	Remote controlled mirror (LH)
<b>E-03 (10)</b>	Powerwindow main switch	<b>E-10 (20-B)</b>	Body wiring harness and door wiring harness (LH) combination
<b>E-04 (4)</b>	Door lock actuator (RH)	<b>E-11 (2-B)</b>	Door speaker (LH)
<b>E-05 (2)</b>	Power window motor (RH)	<b>E-12 (2)</b>	Limit switch (LH)
<b>E-06 (2)</b>	Limit switch (RH)	<b>E-13 (2)</b>	Power window motor (LH)
<b>E-07 (2-B)</b>	Door speaker (RH)	<b>E-14 (4)</b>	Door lock actuator (LH)

LUGGAGE COMPARTMENT

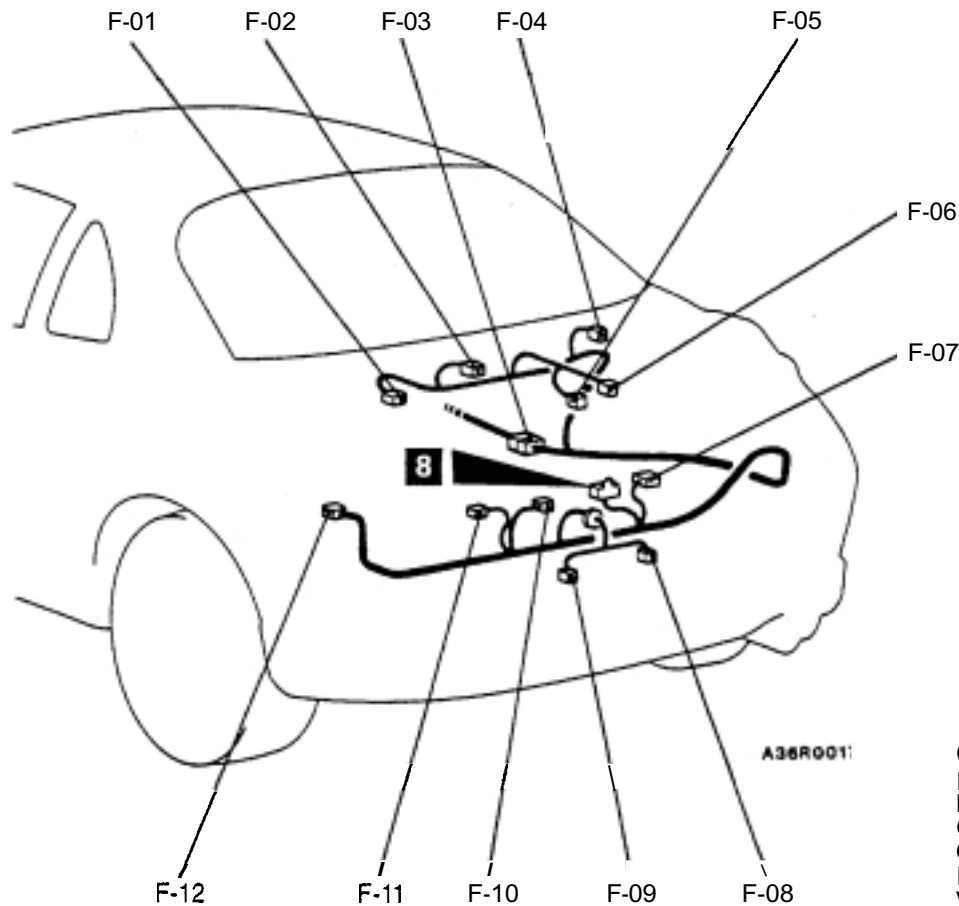
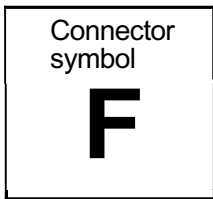

- Connector colour code
- B :Black
  - BR :Brown
  - G :Green
  - GR :Gray
  - L :Blue
  - V :Violet
  - SB :Sky blue
  - LG :Light green
  - O :Orange
  - P :Pink
  - R :Red
  - Y :Yellow
  - W :White

F-01 (2-B)	Rear speaker (LH)	F-07 (6)	Rear combination lamp (RH)
F-02 (2)	Luggage compartment lamp	F-08 (2-GR)	License plate lamp (RH)
F-03 (22)	Body wiring harness and rear wiring harness combination	F-09 (2-GR)	License plate lamp (LH)
F-04 (2-6)	Rear speaker (RH)	F-10 (1-B)	Luggage compartment lamp switch
F-05 (8)	Rear intermittent wiper relay	F-11 (6)	Rear combination lamp (LH)
F-06 (3)	Rear wiper motor	F-12 (6)	Motor antenna assembly

---

NOTES



---

# SINGLE PART INSTALLATION POSITION

## CONTENTS

RELAY .....	3-2	INSPECTION CONNECTOR .....	3-9
ECU .....	3-3	FUSIBLE LINK AND FUSE .....	3-10
SENSOR .....	3-5	EARTH CABLE .....	3-11
SOLENOID VALVE .....	3-7	EARTH .....	3-11
DIODE .....	3-8		

---

## RELAY

Name	Symbol	Name	Symbol
ABS motor relay	A	Engine control relay	F
ABS valve relay	A	Fuel pump relay	F
Alternator relay	A	Headlamp relay	A
A/C compressor relay	A	Headlamp relay <Vehicles with discharge type headlamp>	A
A/T relay	E	Horn relay	A
		Power window relay	A
Blower high speed relay	D	Radiator fan relay	A
Blower relay	C	Rear intermittent wiper relay	G
Condenser fan relay	A	Turn-signal and hazard warning flasher unit	C
Defogger relay	C	Windshield intermittent wiper relay	B

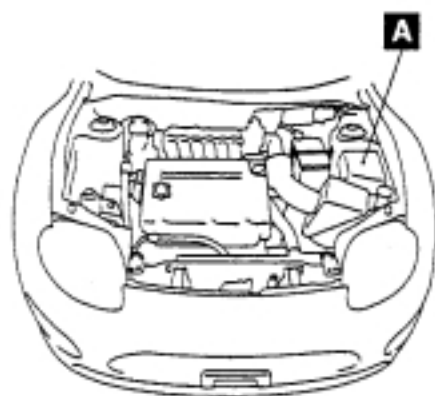

16R0009

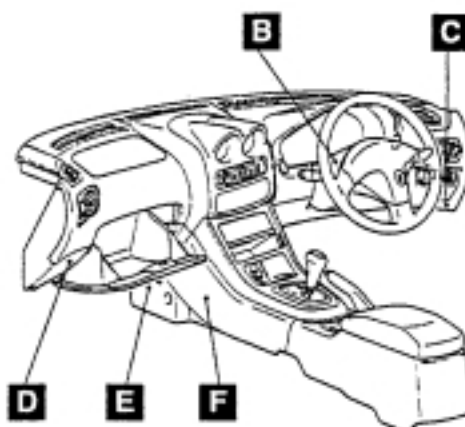

B21A046

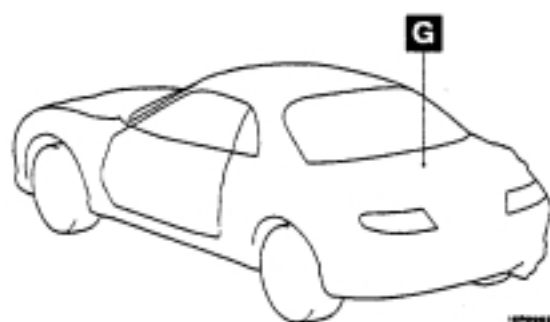

00008470

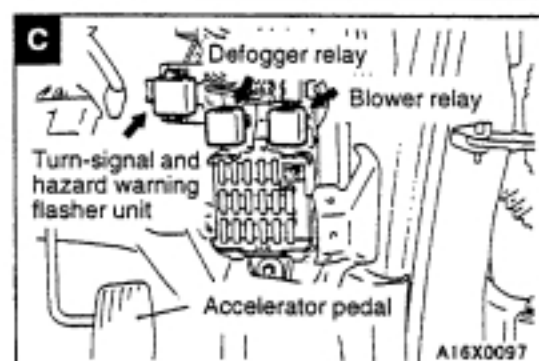
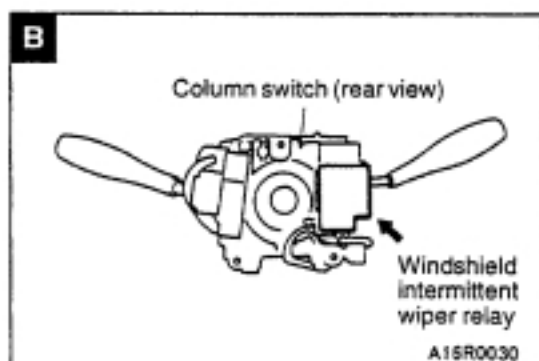
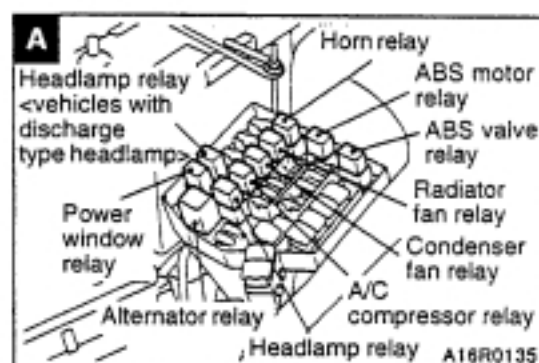

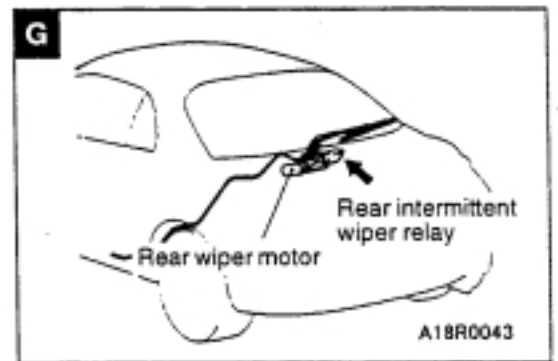
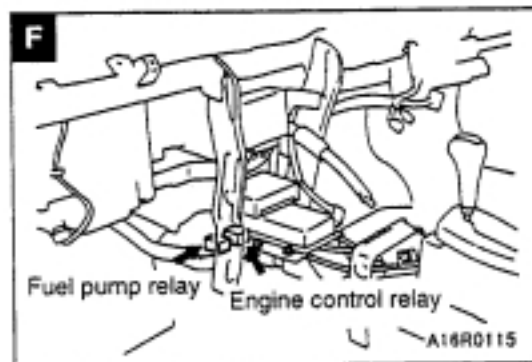
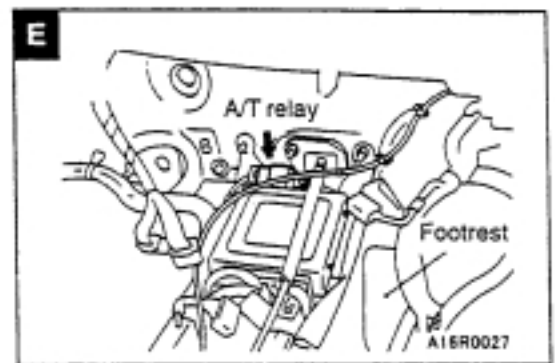
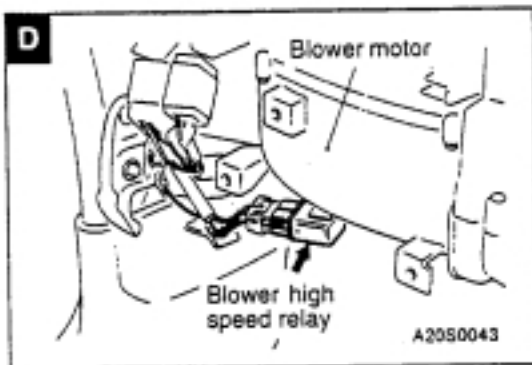

**ECU**

Name	Symbol	Name	Symbol
ABS-ECU	E	Motor antenna-ECU (Motor antenna assembly)	I
A/C-ECU	A		
A/T-ECU	D	Power window sub switch	F
Buzzer-ECU	B	Power window main switch	F
Discharge type headlamp-ECU	J	Remote controlled mirror-ECU	B
Door lock-ECU	B	SRS-ECU	E
Engine-ECU	C	Sunroof-ECU	G
Keyless entry receiver	H	TCL-ECU	E

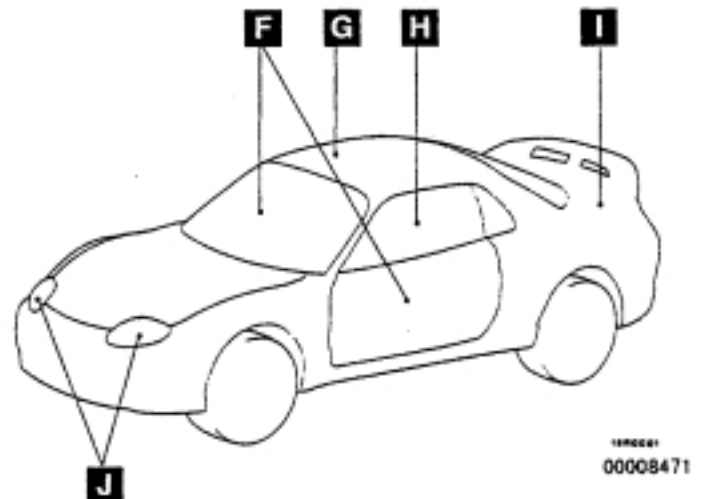
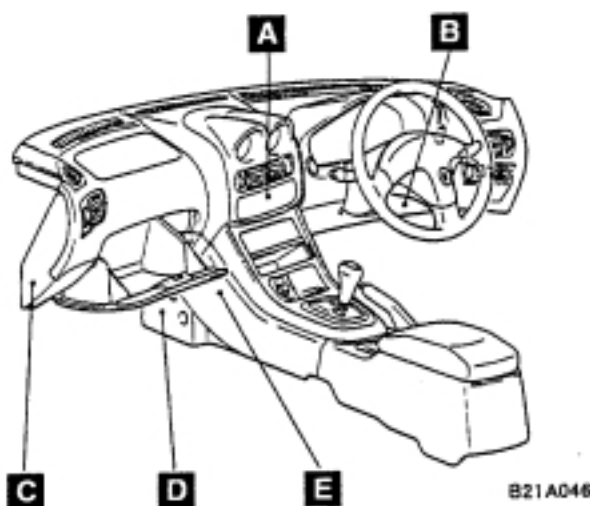



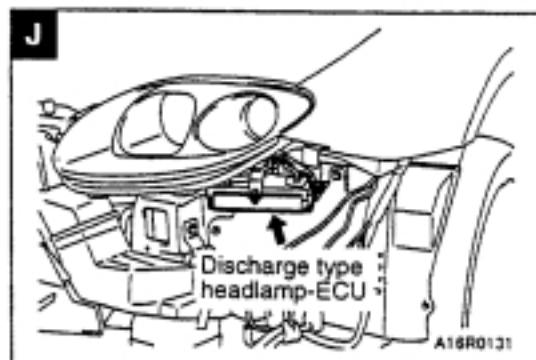
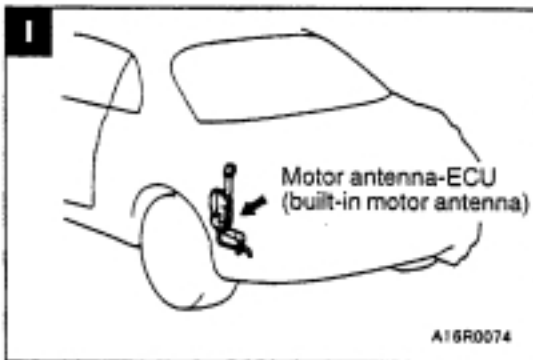
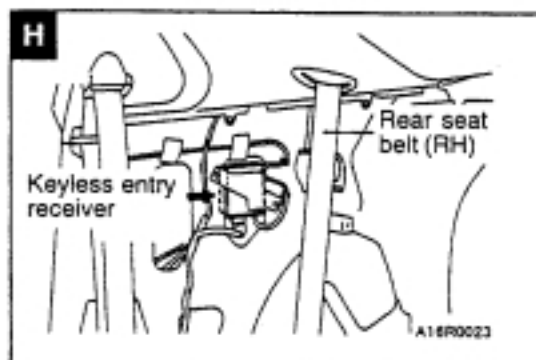
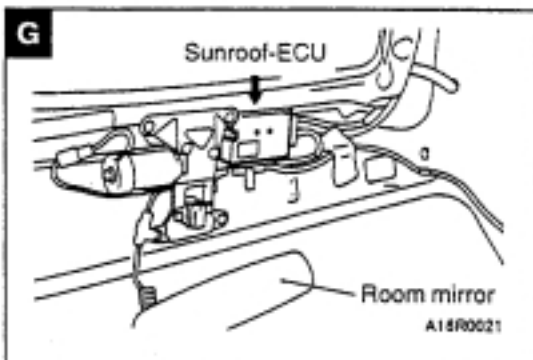
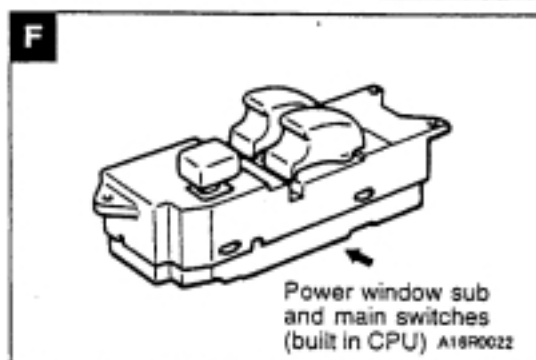
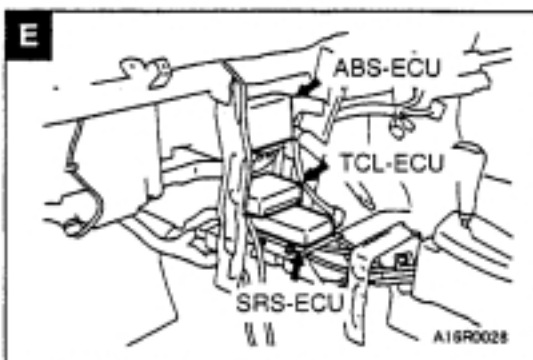
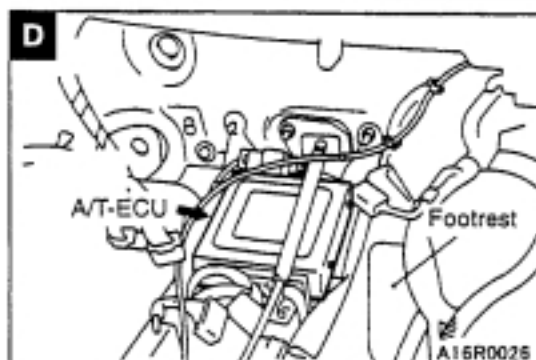
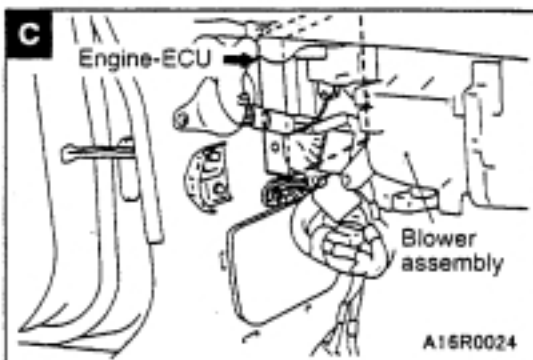
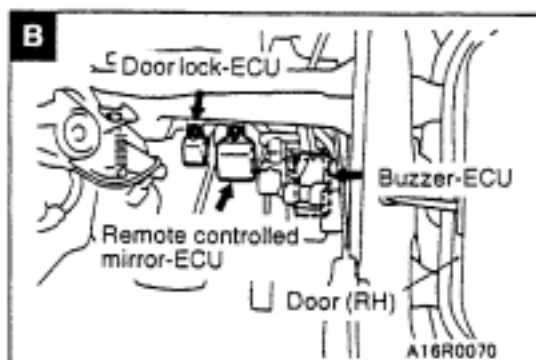
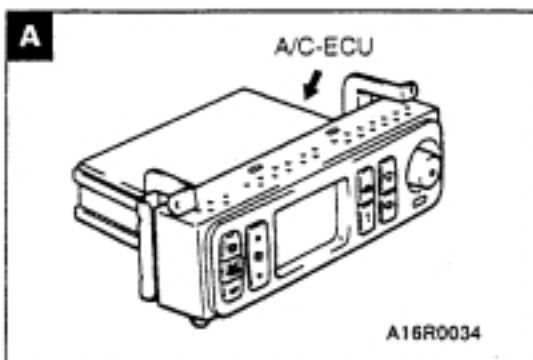

**SENSOR**

Name	Symbol	Name	Symbol
Accelerator pedal position sensor	D	Ignition failure sensor	E
Air thermo sensor <Full automatic air conditioner>	L	Intake air control valve position sensor (built-in variable induction control servo)	B
Atmospheric pressure sensor	C	Intake air temperature sensor	B
A/T fluid temperature sensor (built-in A/T control solenoid valve assembly)	I	Outside temperature sensor <Full automatic air conditioner>	F
Camshaft position sensor	A	Oxygen sensor	O
Crank angle sensor	A	Photo sensor <Full automatic air conditioner>	J
Detonation sensor	G	Rear speed sensor <ABS>	P
Engine coolant temperature sensor (for engine control)	E	Steering wheel sensor <TCL>	K
Front speed sensor <ABS>	N	Throttle position sensor	D
Heater water temperature sensor <Full automatic air conditioner>	M	Vehicle speed sensor	H

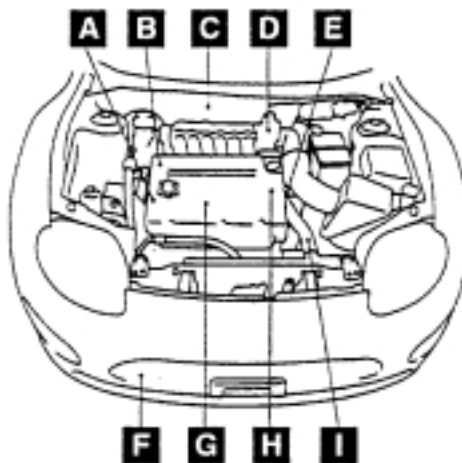

16R0009

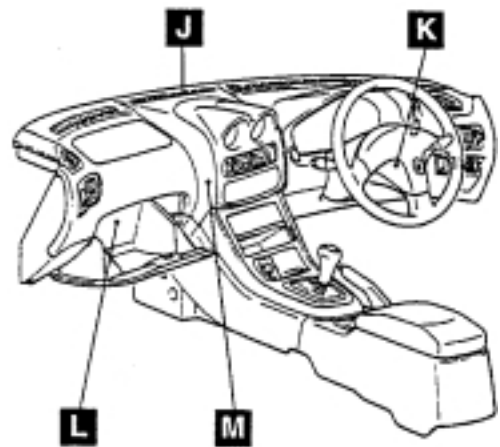

B21A046

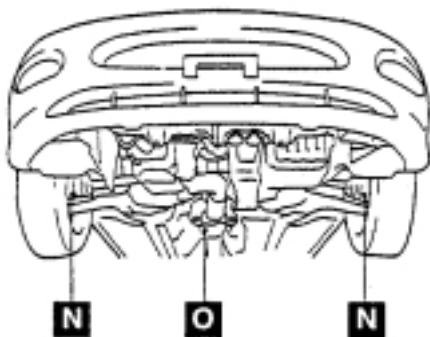

16R0010

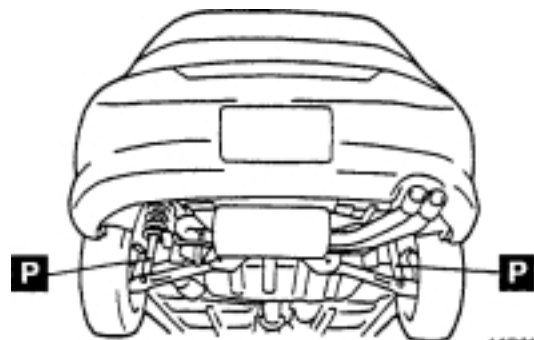

16R0011

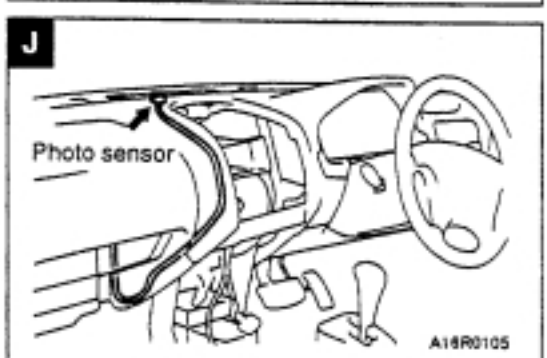
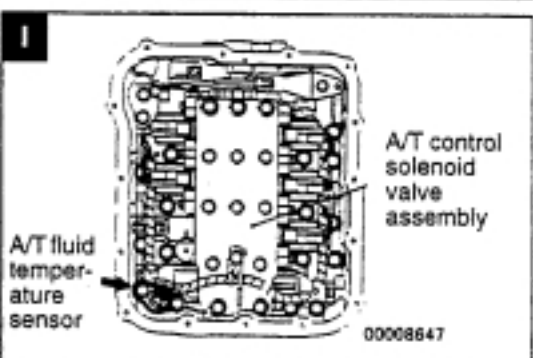
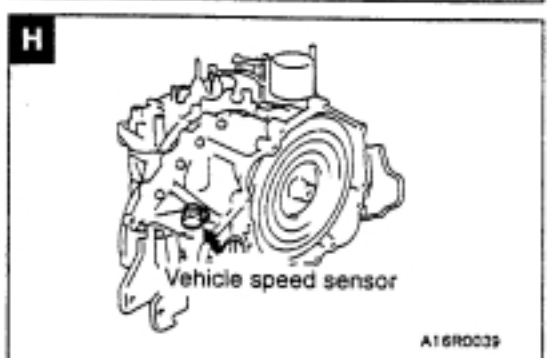
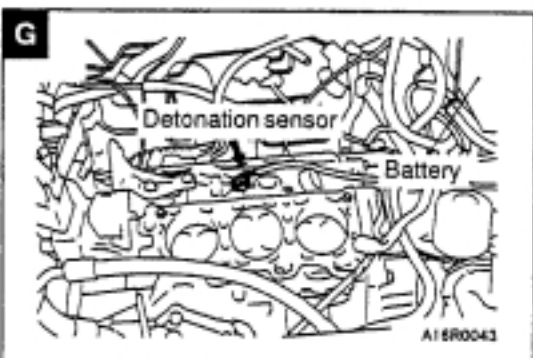
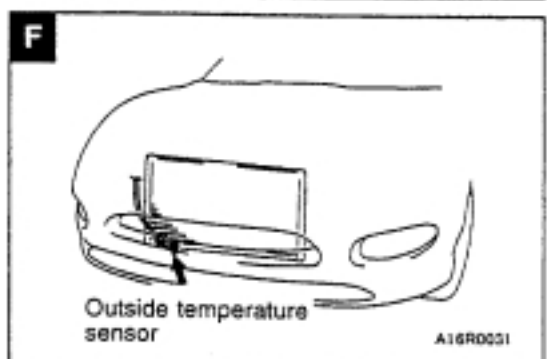
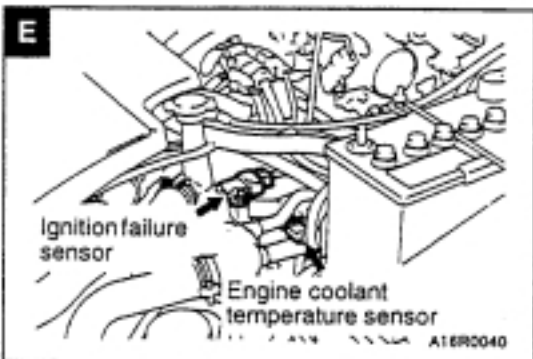
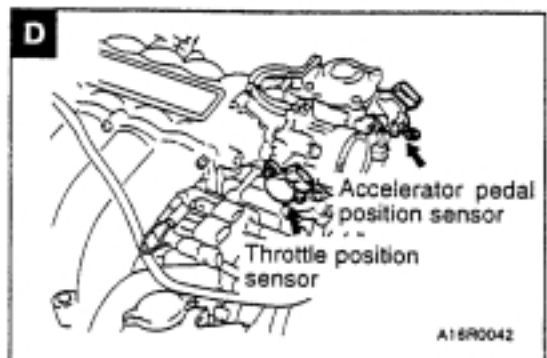
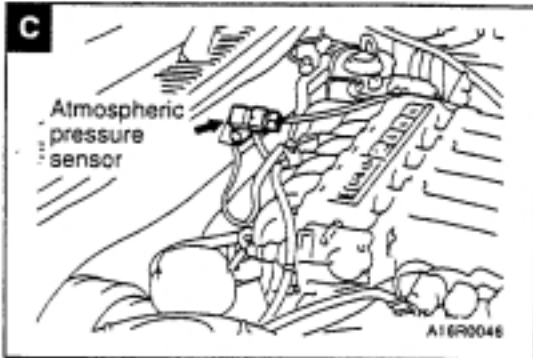
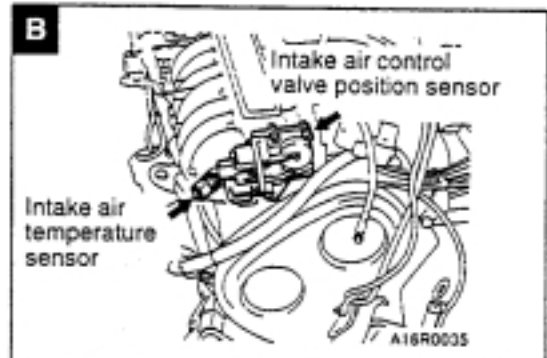
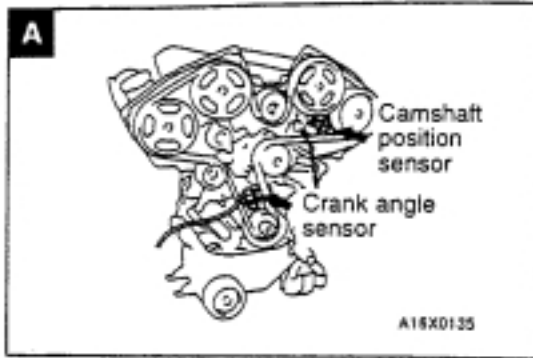

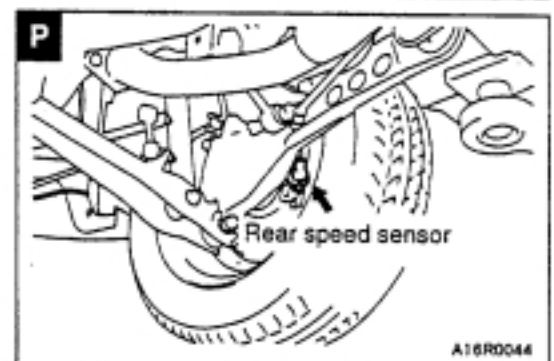
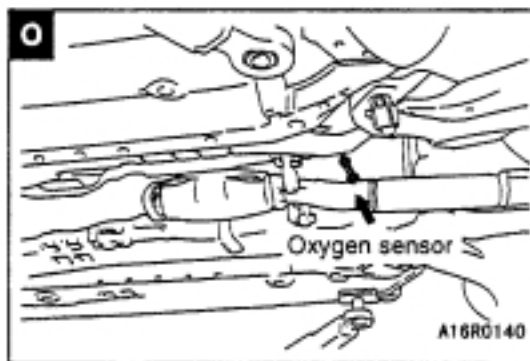
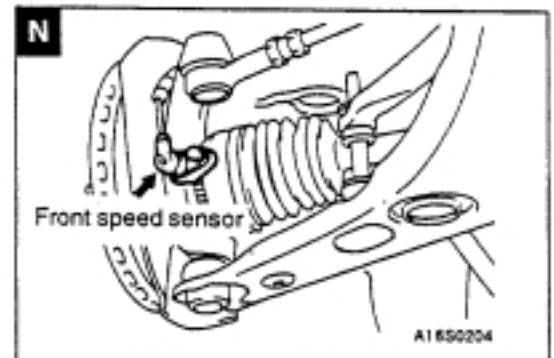
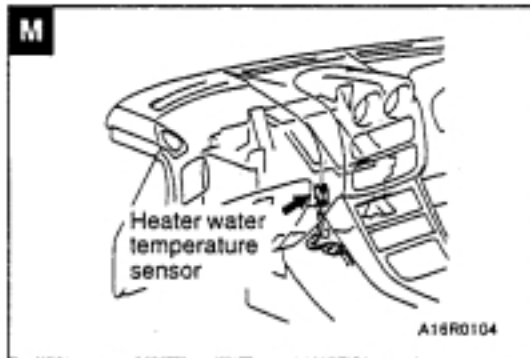
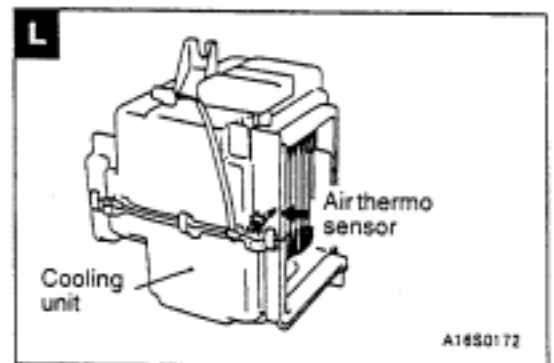
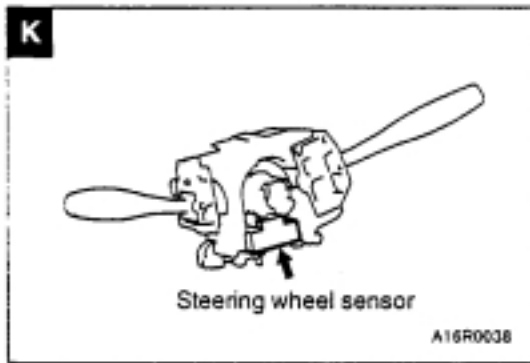

## SOLENOID VALVE

Name	Symbol	Name	Symbol
A/T control solenoid valve assembly	E	Oil control valve (right bank side)	B
ABS solenoid valve (built-in hydraulic unit)	D	Vacuum solenoid valve <TCL>	C
Oil control valve (left bank side)	A	Ventilation solenoid valve <TCL>	C

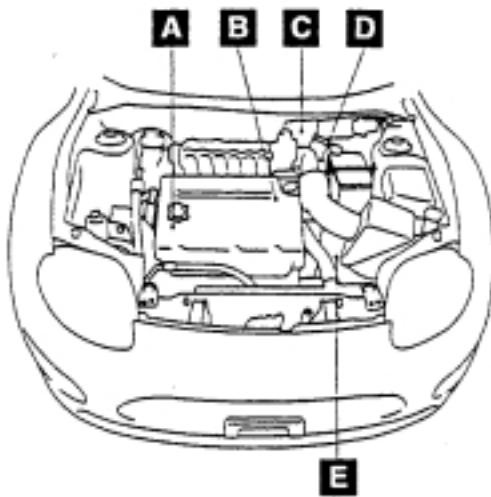

A16R0009

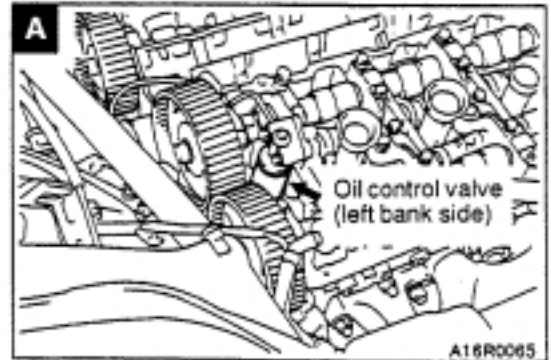

A16R0065

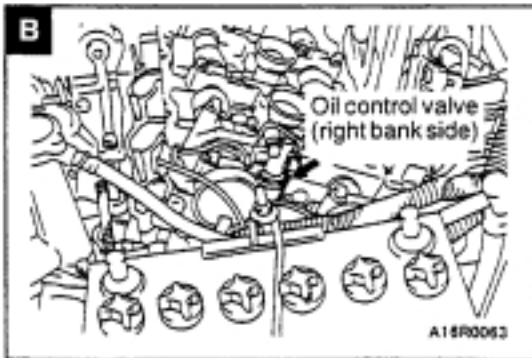

A16R0063

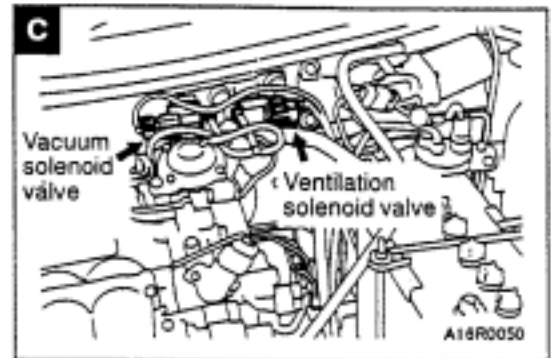

A16R0050

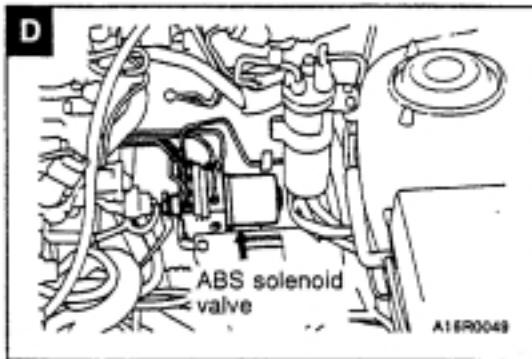

A16R0049

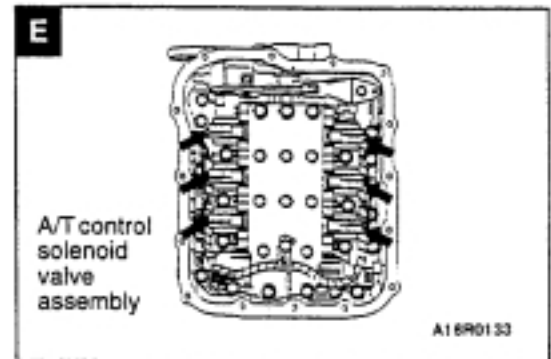

A16R0133

DIODE

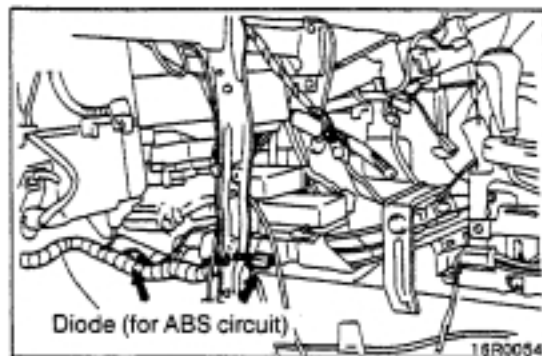

16R0054

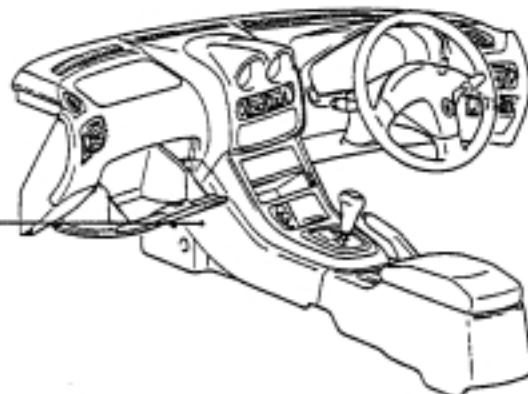

B21A046

# INSPECTION CONNECTOR

Name	Symbol	Name	Symbol
Diagnosis code erase connector <ABS>	B	Engine speed detection connector	A
Diagnosis connector	C		

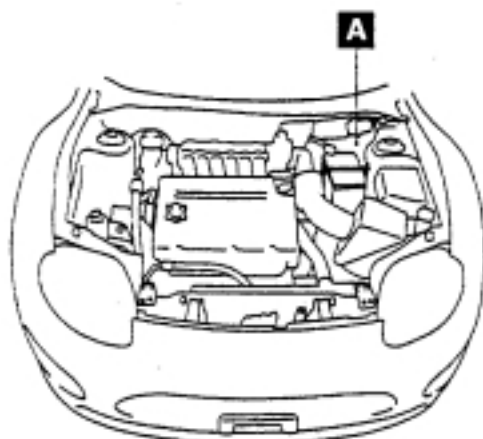

16R0009

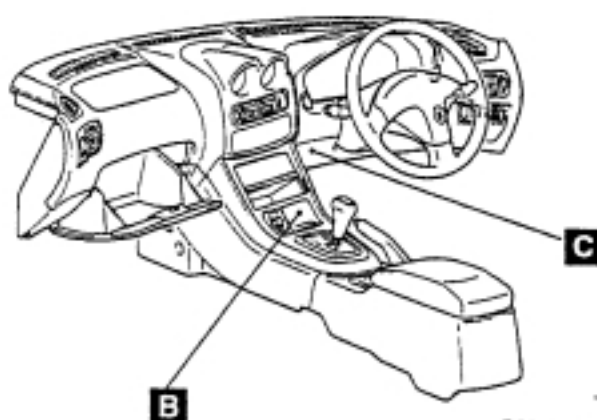

B21A046

00003474

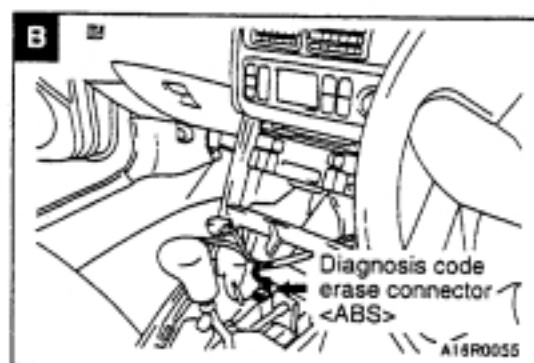
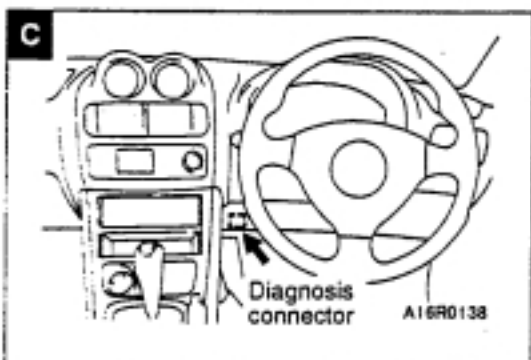
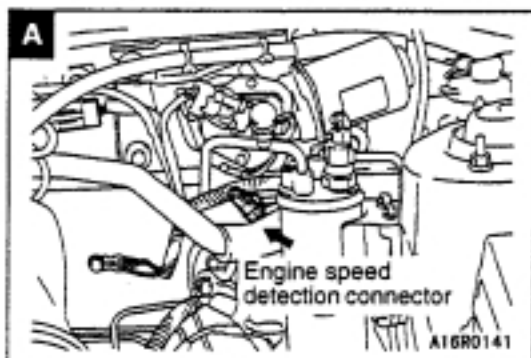

### 3-10 SINGLE PART INSTALLATION POSITION – Fusible Link and Fuse

## FUSIBLE LINK AND FUSE

Name	Symbol	Name	Symbol
Dedicated fuse	A	Multi-purpose fuse	B
Fusible link	A		

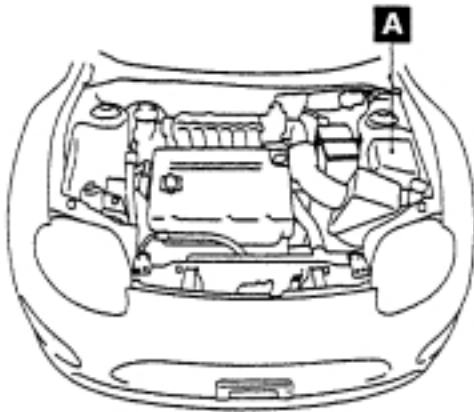

15R0009

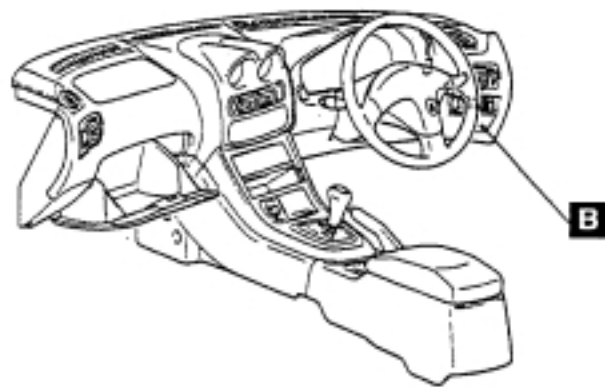

B21A046  
00008475

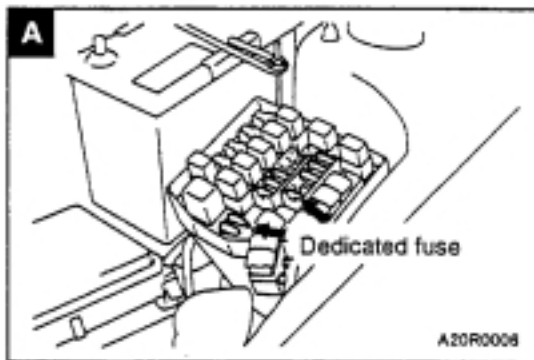

A20R0008

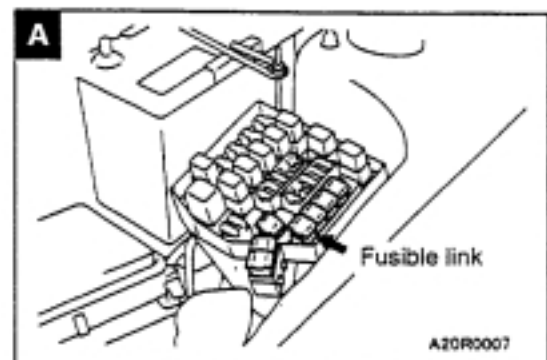

A20R0007

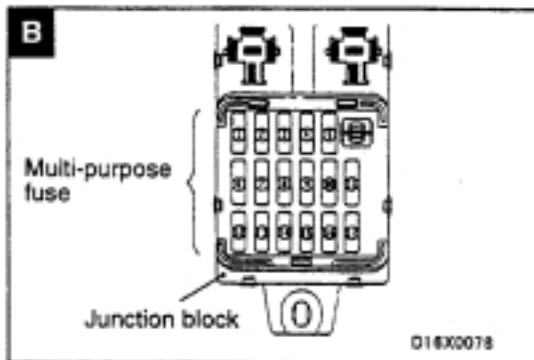

016X0078



## EARTH CABLE

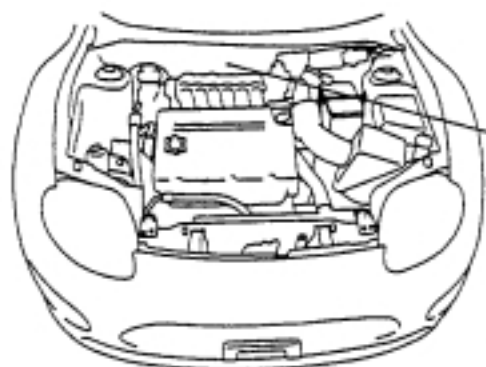

16R0009

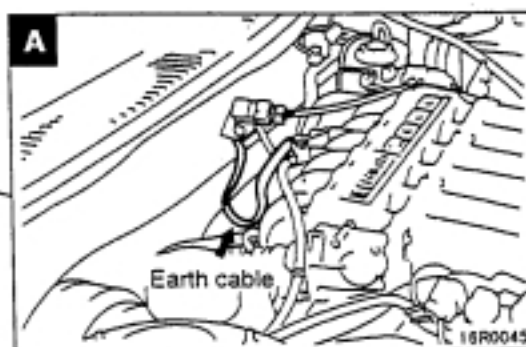

0000476

## EARTH

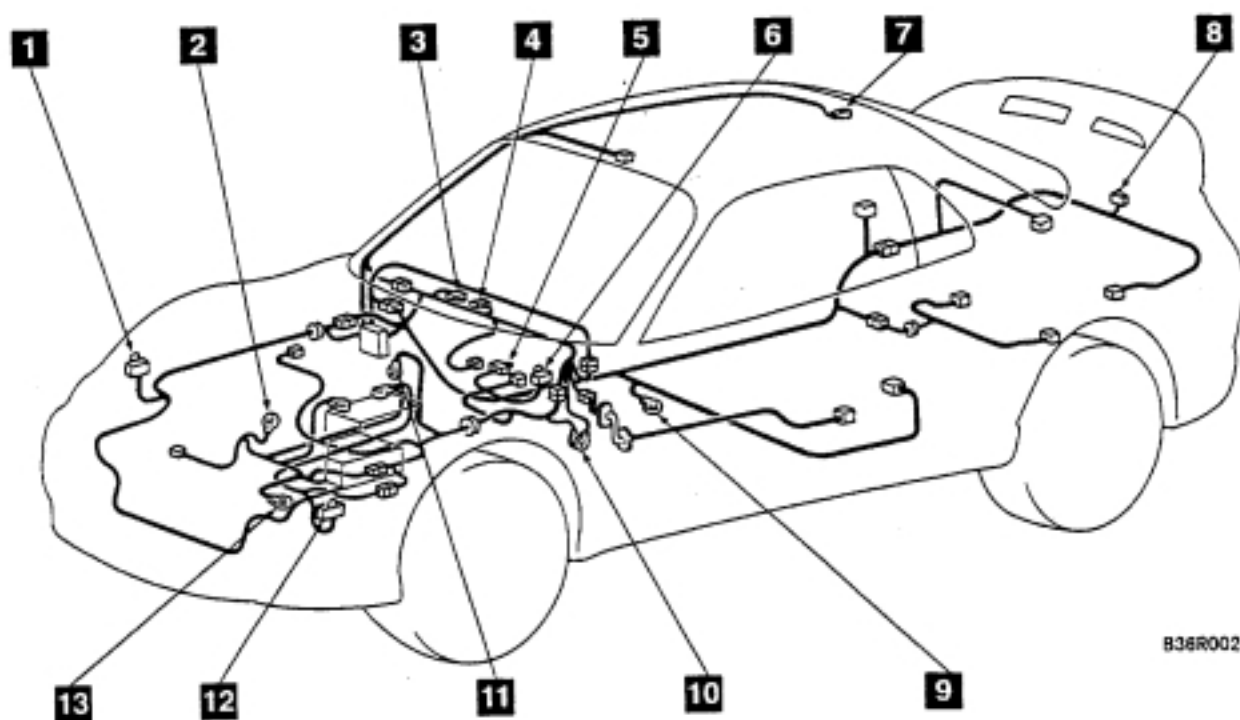

B36R0024

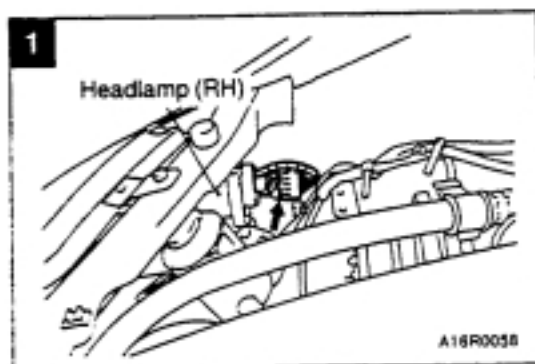

A16R0058

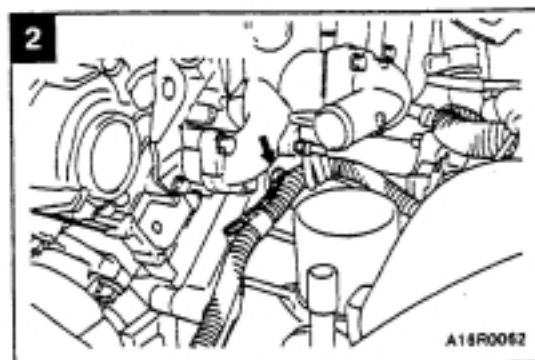

A16R0062



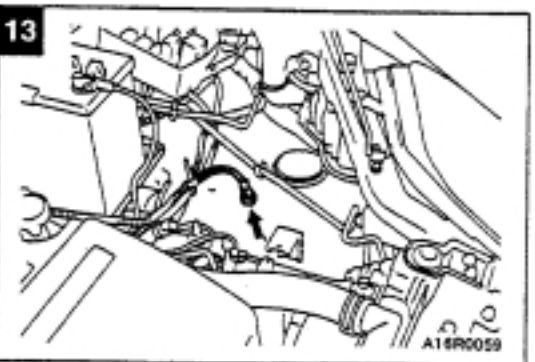
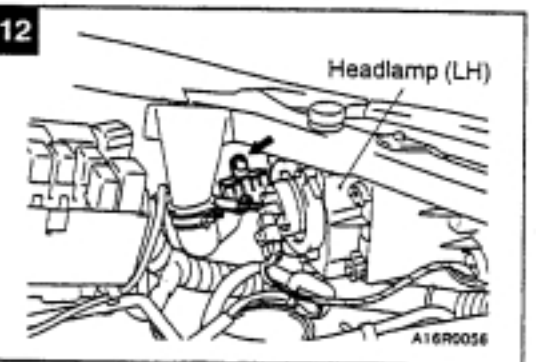
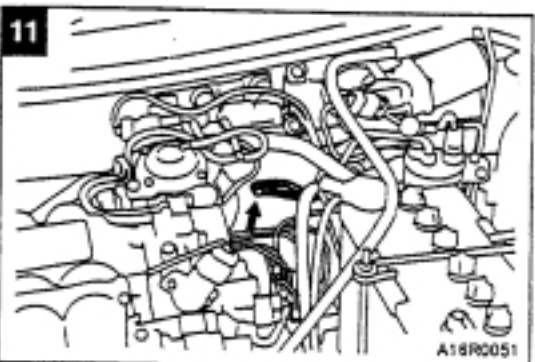
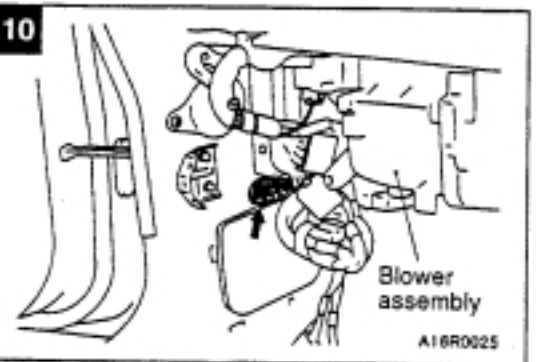
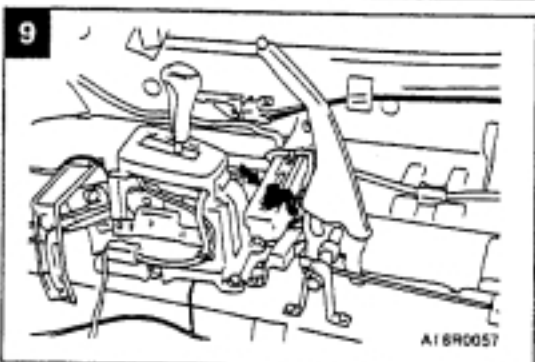
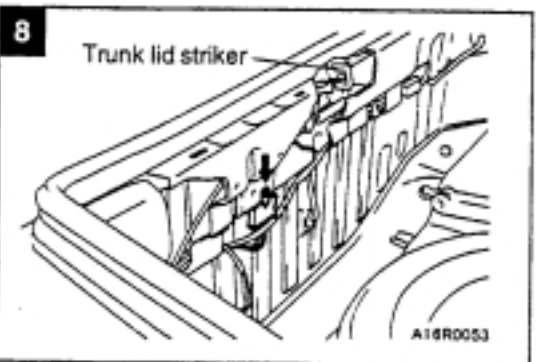
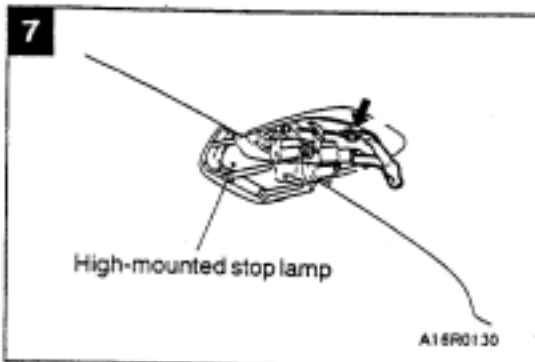
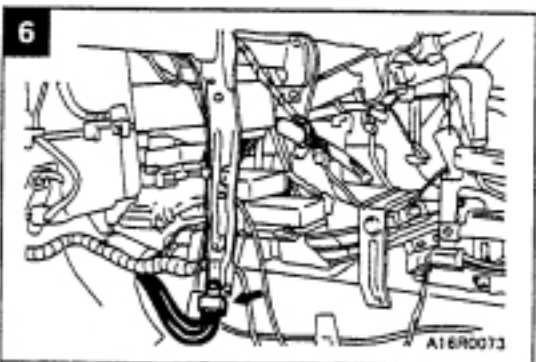
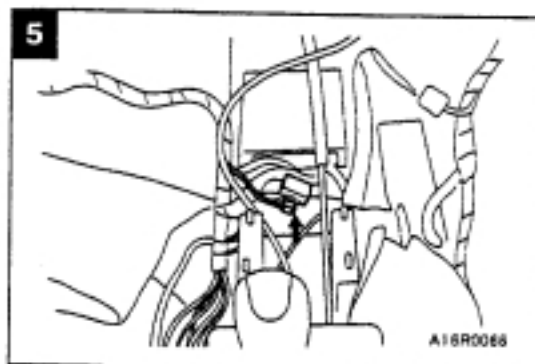
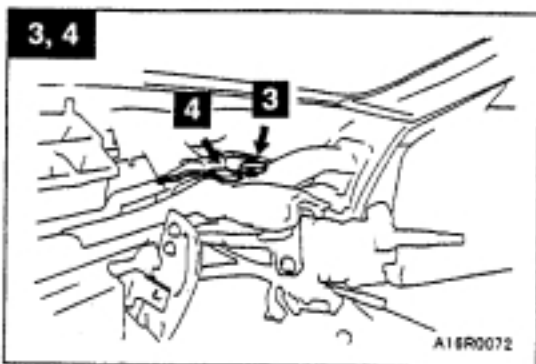

# CIRCUIT DIAGRAM

## CONTENTS

JUNCTION BLOCK (J/B) .....	4-4	IGNITION KEY CYLINDER ILLUMINATION LAMP .....	4-63
JOINT CONNECTOR (J/C) .....	4-6	MAP LAMP AND LUGGAGE COMPARTMENT LAMP .....	4-64
CENTRALIZED JUNCTION .....	4-9	TURN-SIGNAL LAMP AND HAZARD WARNING LAMP .....	4-66
POWER DISTRIBUTION SYSTEM .....	4-14	STOP LAMP .....	4-68
STARTING SYSTEM .....	4-19	BACK-UP LAMP <M/T> .....	4-69
IGNITION SYSTEM .....	4-20	BACK-UP LAMP AND REVERSE (R) POSITION WARNING BUZZER <A/T> .....	4-70
CHARGING SYSTEM .....	4-22	HORN .....	4-71
ENGINE CONTROL SYSTEM		METER AND GAUGE .....	4-72
Vehicles without TCL .....	4-24	OIL PRESSURE WARNING LAMP .....	4-74
Vehicles with TCL .....	4-32	FUEL WARNING LAMP .....	4-74
COOLING SYSTEM .....	4-39	BRAKE WARNING LAMP .....	4-75
INVECS-II 5A/T		SEAT BELT WARNING LAMP .....	4-75
Vehicles without TCL .....	4-40	POWER WINDOWS .....	4-76
Vehicles with TCL .....	4-48	CENTRAL DOOR LOCKING AND KEYLESS ENTRY SYSTEMS .....	4-78
HEADLAMP		FULL-AUTO AIR CONDITIONER .....	4-82
Except for discharge type .....	4-56	WINDSHIELD WIPER AND WASHER .....	4-88
Discharge type .....	4-58		
TAIL LAMP, POSITION LAMP AND LICENSE PLATE LAMP			
Vehicles without discharge type headlamp ...	4-60		
Vehicles with discharge type headlamp .....	4-61		
FOG LAMP .....	4-62		

---

REAR WIPER AND WASHER .....	4-90	LIGHTING MONITOR BUZZER .....	4-101
DEFOGGER.....	4-92	KEY REMINDER BUZZER .....	4-102
ELECTRIC RETRACTABLE REMOTE-CONTROLLED MIRROR .....	4-94	SUNROOF .....	4-103
RADIO .....	4-96	ANTI-SKID BRAKING SYSTEM (ABS) ...	4-104
CLOCK .....	4-99	TRACTION CONTROL SYSTEM (TCL) ...	4-108
CIGARETTE LIGHTER AND ASHTRAY ILLUMINATION LAMP .....	4-100	SUPPLEMENTAL RESTRAINT SYSTEM (SRS) .....	4-112

---

---

NOTES

JUNCTION BLOCK (J/B)

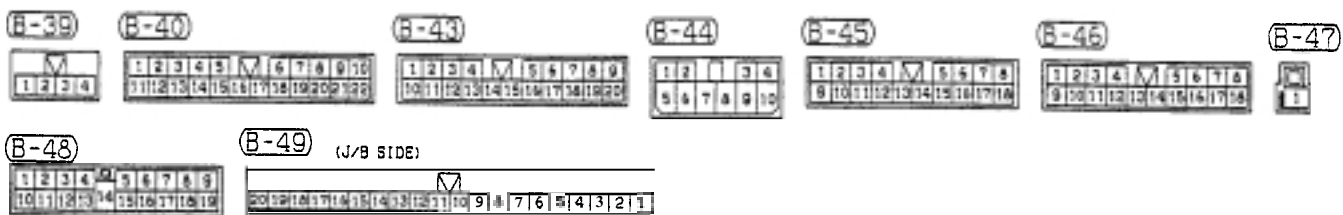
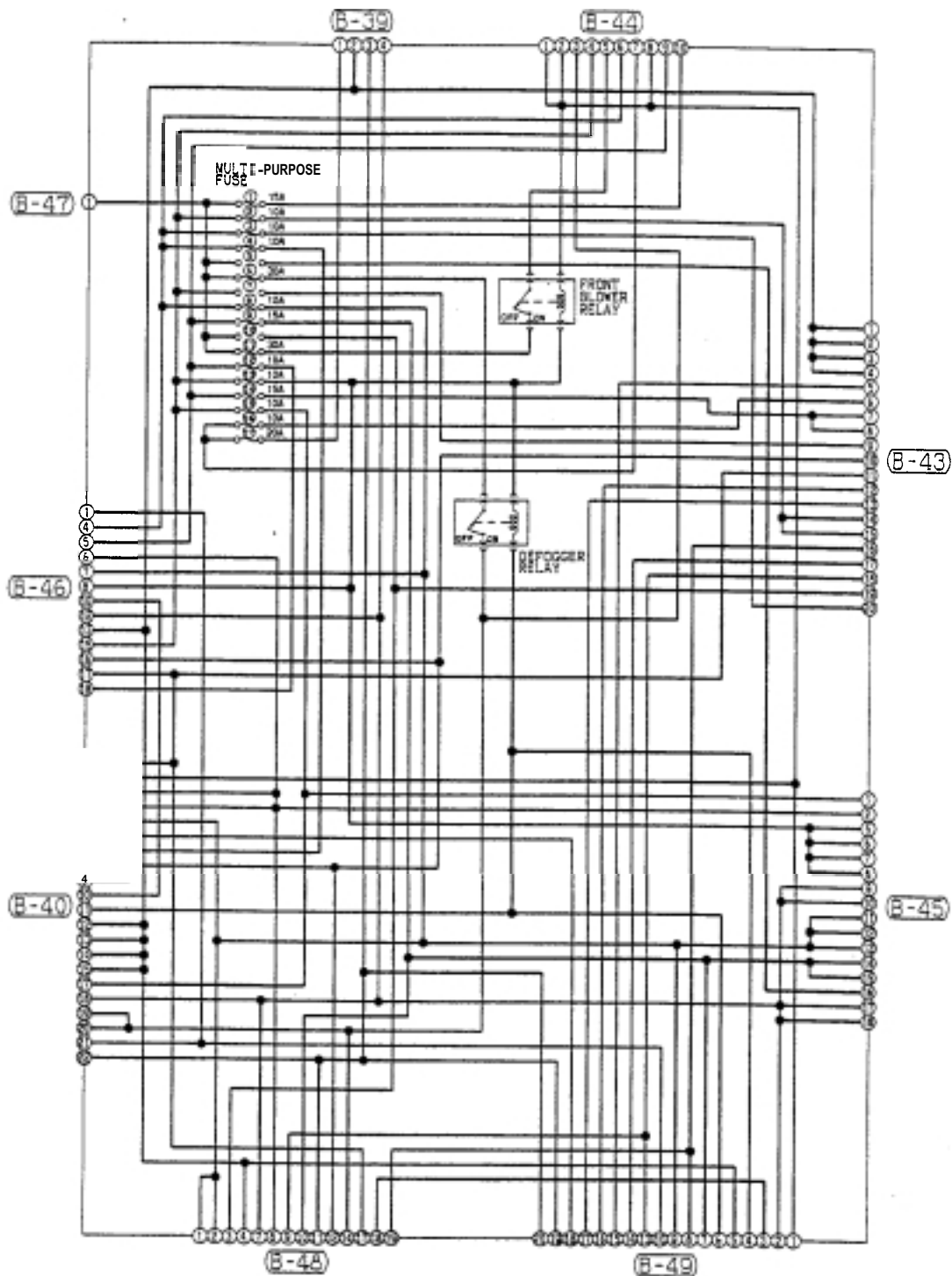

**[Front side]**

**[Rear side]**

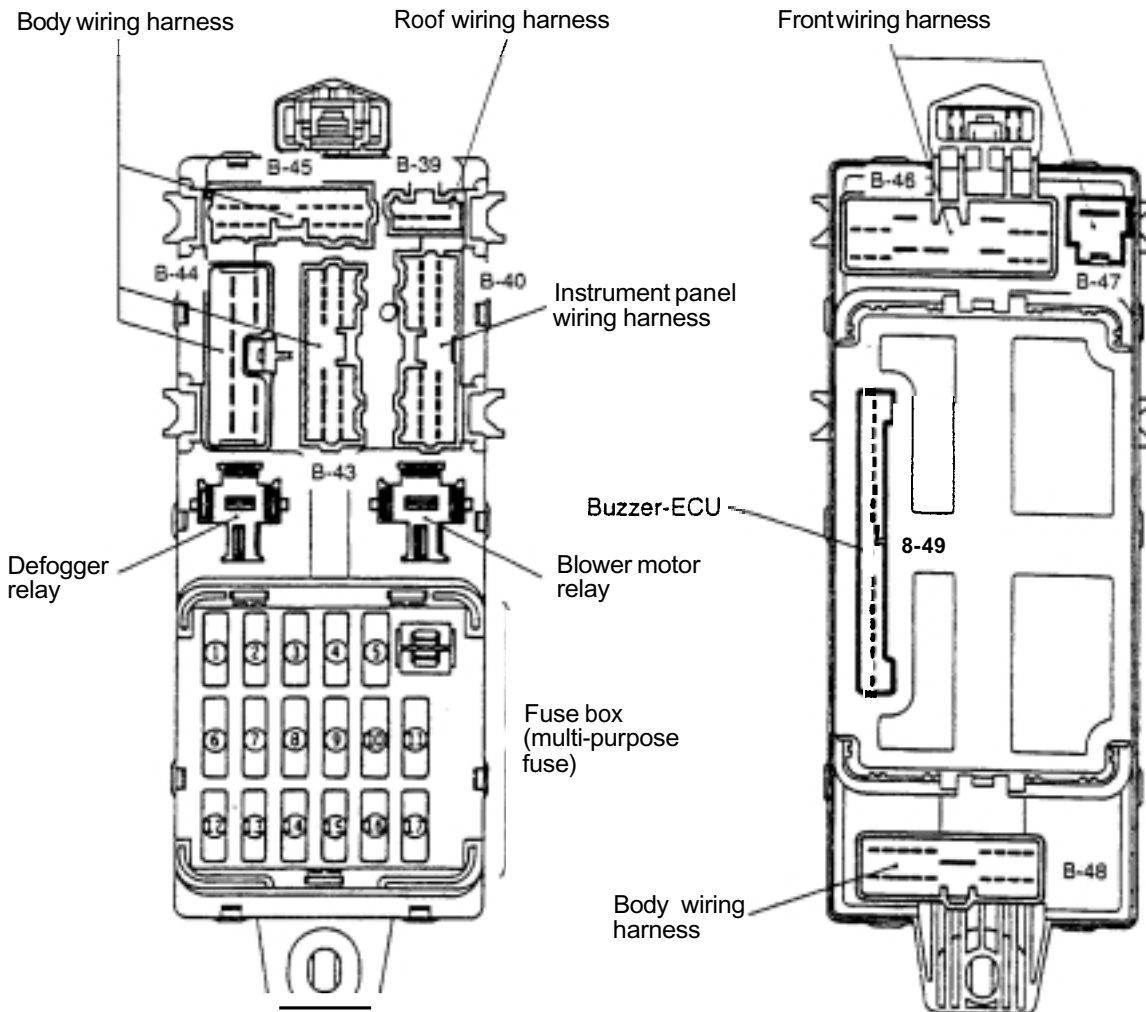

16X0078

16X0079  
00008477

JOINT CONNECTOR (J/C)

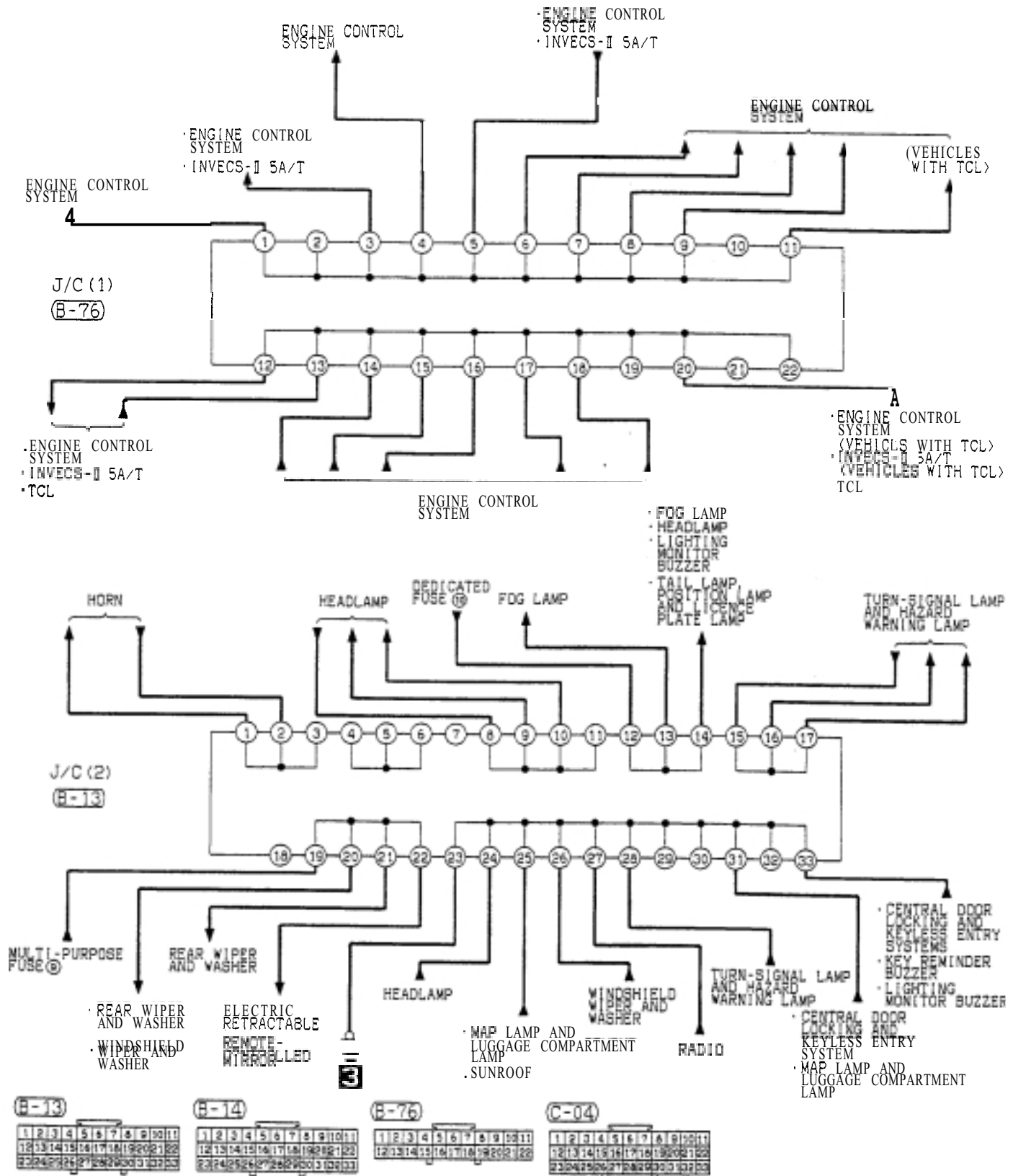

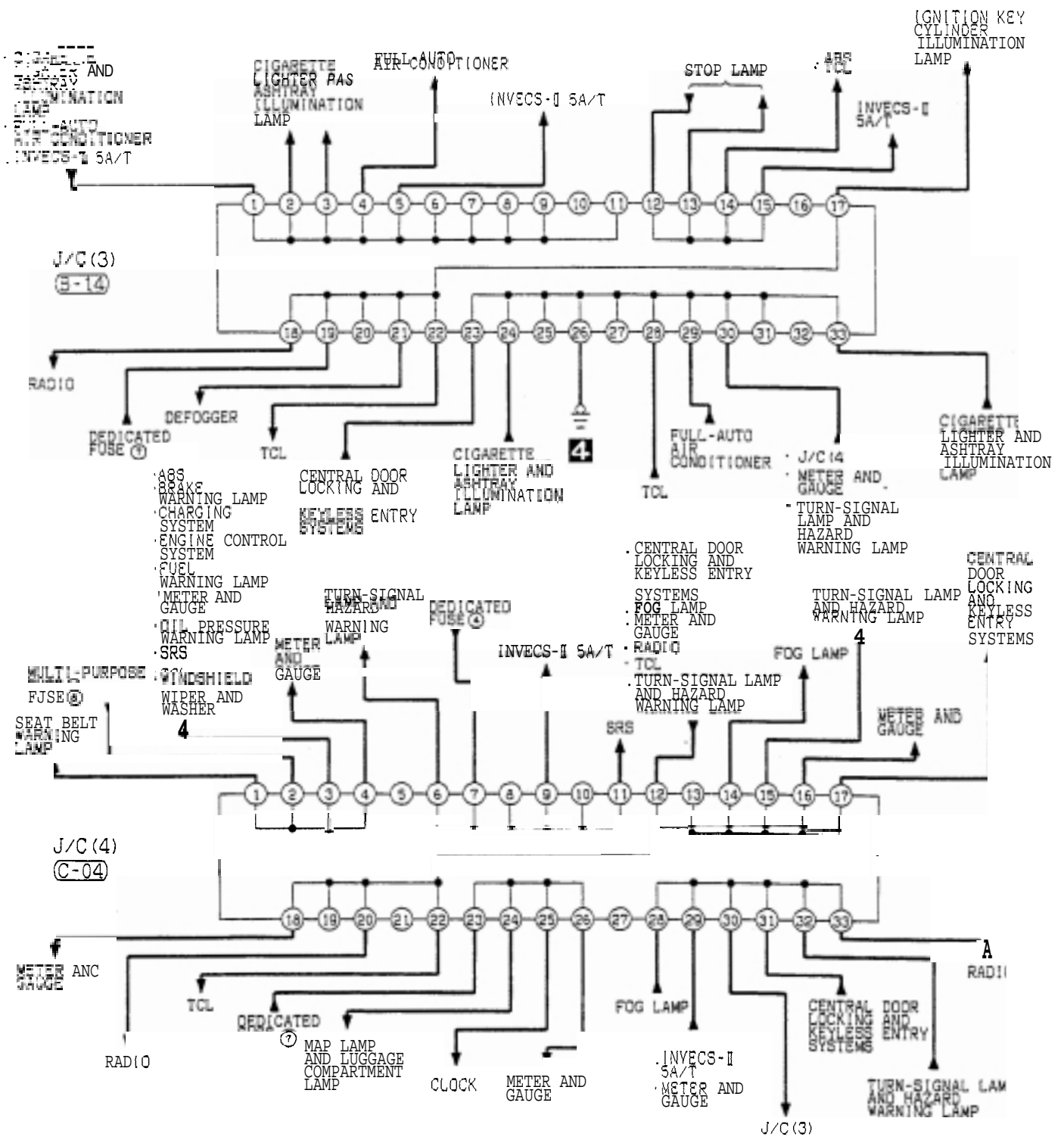

REMARK  
 IN ACTUAL VEHICLES, ANY OF THE TERMINALS CONNECTED IN J/C ARE USED. THE TERMINALS DESCRIBED IN THE CIRCUIT DIAGRAM MAY NOT BE IDENTICAL TO THOSE OF THE VEHICLES.



JOINT CONNECTOR (J/C) (CONTINUED)

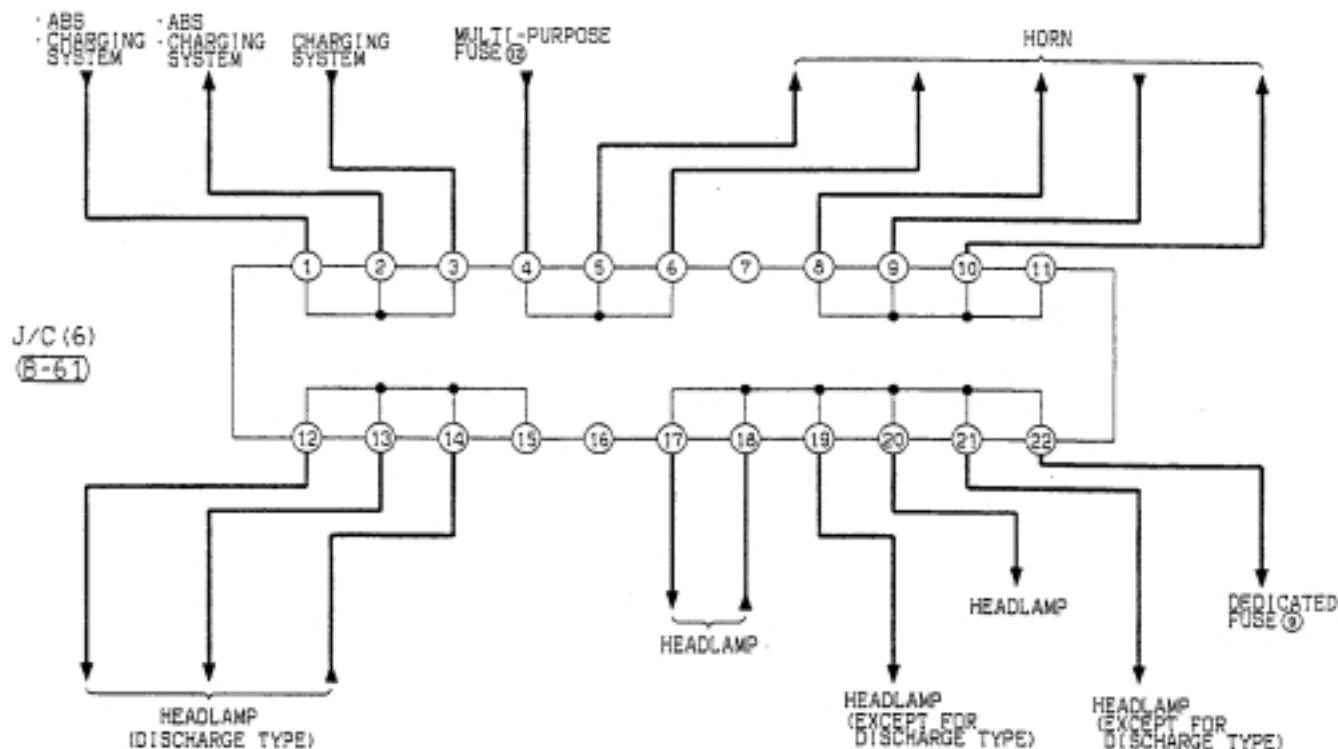
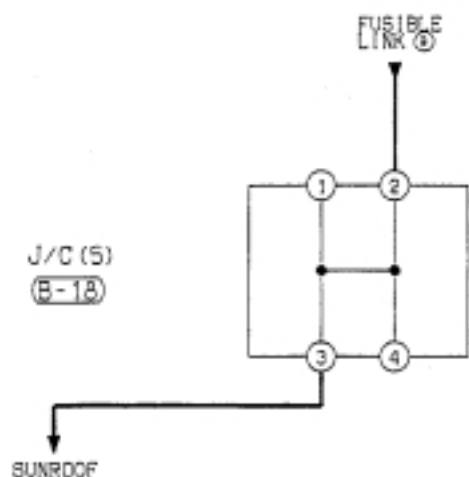

(B-18)

(B-61)

13
34

1	2	3	4	5	6	7	8	9	10	11
12	13	14	15	16	17	18	19	20	21	22

REMARK  
IN ACTUAL VEHICLES, ANY OF THE TERMINALS CONNECTED IN J/C ARE USED. THE TERMINALS DESCRIBED IN THE CIRCUIT DIAGRAM MAY NOT BE IDENTICAL TO THOSE OF THE VEHICLES.

**CENTRALIZED JUNCTION**

**FUSIBLE LINK (RELAY BOX INSIDE ENGINE ROOM)**

No.	Circuit	Type	Housing color	Rated capacity (A)
1	Dedicated fuse No. (7), (8), multi-purpose fuse No. (1), (6), (11)	Screw type	Yellow	50
2	Fusible link No. (1), (8), (9), dedicated fuse No.(1) (when engine stops), Fusible link No. (3), (4), (5), (6), dedicated fuse No.(3), (4), (5) (when engine starts)	Screw type	Dark blue	100
3	INVECS-II 5AVT, TCL. engine control	Connector type	Blue	20
4	Dedicated fuse No.(10), charging, headlamp	Connector type	Green	40
5	Full-auto air conditioner, cooling	Connector type	Pink	30
6	Ignition switch	Connector type	Green	40
7	-	-	-	-
8	ABS	Connector type	Red	50
9	Multi-purpose fuse No. (16), (17), power window	Connector type	Pink	30

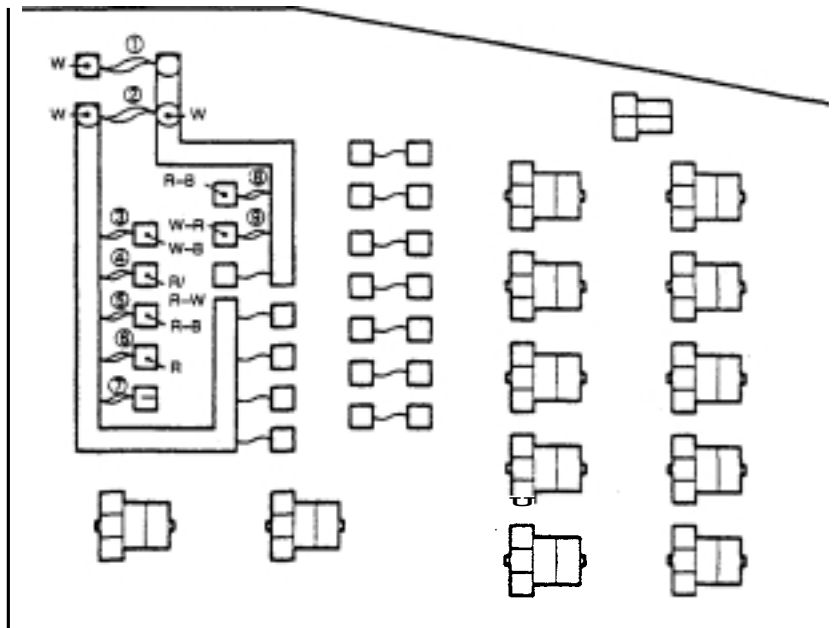

A16R0106

## DEDICATED FUSE (RELAY BOX INSIDE ENGINE ROOM)

Power supply circuit	Fuse No.	Rated capacity (A)	Housing color	Circuit
Battery (fusible link No.2)/Alternator	1	30	Pink	Condenser fan
-	2	-	-	-
Battery/alternator (fusible link No.2)	3	15	Blue	Fog lamp
	4	10	Red	Turn-signal and hazard warning lamp
	5	15	Blue	Stop lamp
Ignition switch (ACC)	6	15	Blue	Keyless entry receiver, motor antenna assembly, spare connector for radio
Battery (fusible link No. 1, 2)/alternator (fusible link No.1)	7	10	Red	A/C-ECU power supply, TCL-ECU power supply, MUT-II power supply, engine-ECU power supply, key cylinder illumination lamp, keyless entry receiver, speedometer, trunk room lamp, clock, door-ajar indicator lamp, buzzer-ECU power supply, map lamp, motor antenna assembly, spare connector for radio
	a	10	Red	A/C compressor
Headlamp relay <vehicles without discharge type headlamp>	9	10	Red	High beam indicator lamp
Headlamp relay (dedicated fuse No.11) <vehicles with discharge type headlamp>				
Battery (fusible link No.4)/alternator (fusible link No.2, 4)	10	10	Red	Illumination lamp, tail lamp, position lamp, license plate lamp, buzzer-ECU
Headlamp relay <vehicles with discharge type headlamp>	11	20	Yellow	Dedicated fuse No.9 (high beam indicator lamp), headlamp (LH)
	12	20	Yellow	Headlamp (RH)

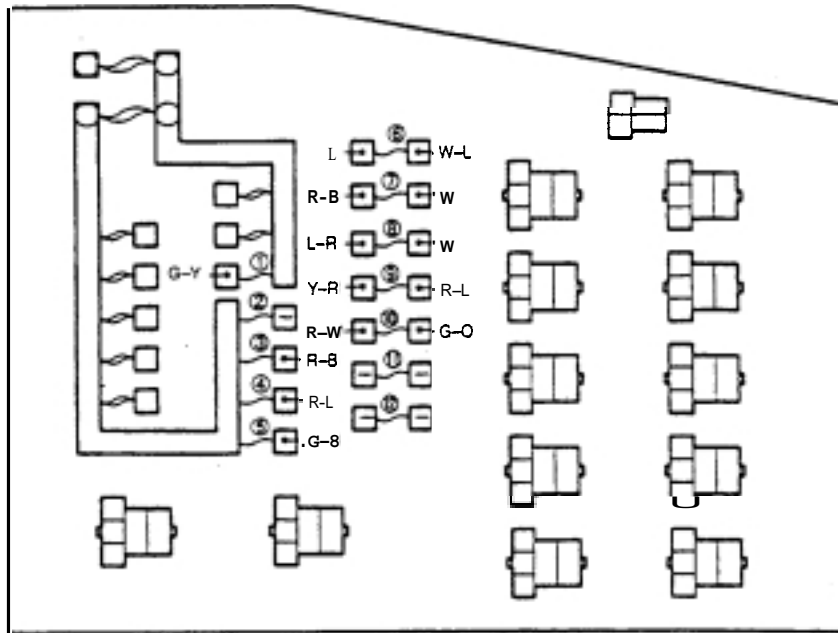

B16R0106

**MULTI-PURPOSE FUSE (INSIDE J/B)**

Power supply circuit	Fuse No.	Rated capacity (A)	Housing color	Load circuit
Battery (fusible link No.1, 2)/alternator (fusible link No.1)	1	15	Blue	Door lock-ECU
Ignition switch	IG2	2	Red	TCL-ECU
	IG1	3	Red	A/T-ECU, A/T indicator lamp, output/input shaft speed sensor, back-up lamp, buzzer-ECU
		4	10	Red
-	5	-	-	-
Battery (fusible link No.1, 2)/alternator (fusible link No.1)	6	30	Pink	Defogger
-	7	-	-	-
Ignition switch	IG1	8	Red	SRS-ECU, combination meter, sunroof-ECU, vehicle speed sensor, steering wheel sensor <vehicles with TCL>, buzzer-ECU, motor antenna assembly, voltmeter

Power supply circuit		Fuse No.	Rated capacity (A)	Housing color	Load circuit
Ignition switch	ACC	9	15	Blue	Windshield intermittent wiper relay, windshield wiper motor, remote-controlled mirror, rear intermittent wiper relay, rear washer motor, rear wiper motor
-		10	-	-	-
Battery (fusible link No.1, 2)/alternator (fusible link No.1)		11	30	Pink	Blower motor
Ignition switch	ACC	12	10	Red	Horn
	IG2	13	10	Red	A/C-ECU, ABS-ECU, ABS valve relay, defogger relay, power window relay, blower high speed relay, blower motor relay
	ACC	14	15	Blue	Cigarette lighter
	IG2	15	10	Red	-
Battery (fusible link No.2, 9)/alternator (fusible link No.9)		16	10	Red	-
		17	20	Yellow	Sunroof-ECU

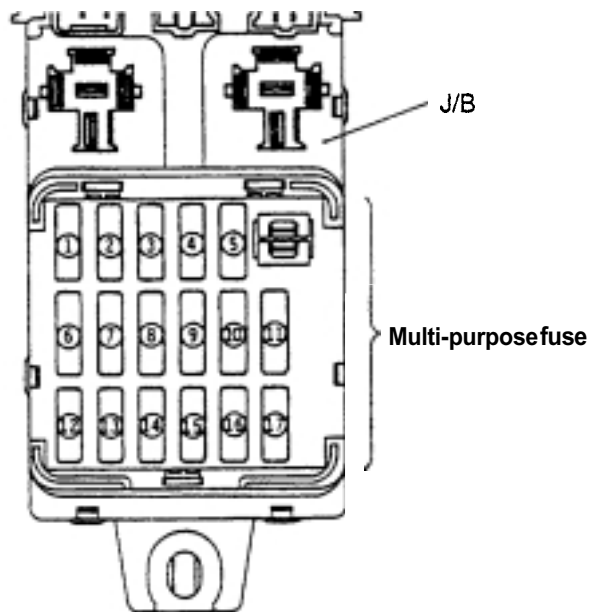

E16X0078

CENTRALIZED RELAY (RELAY BOX INSIDE ENGINE ROOM)

Connector NO.	Name	Connector No.	Name
A-52X	ABS valve relay	A-59X	Alternator relay
A-53X	ABS motor relay	A-60X	Power window relay
A-54X	Headlamp relay	A-61X	Headlamp relay (vehicles with discharge type headlamp)
A-55X	A/C compressor relay	A-62X	-
A-56X	Condenser fan relay	A-63X	-
A-57X	Radiator fan relay	A-64X	-
A-58X	Horn relay	-	-

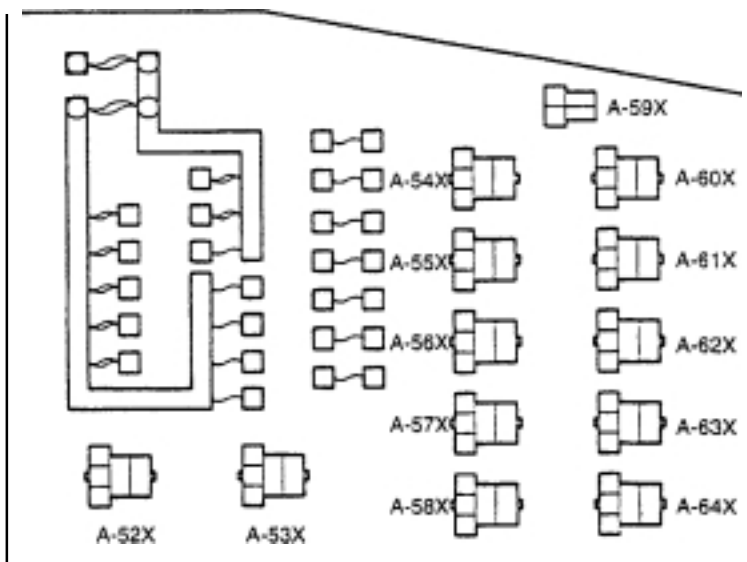

10P01104

POWER DISTRIBUTION SYSTEM

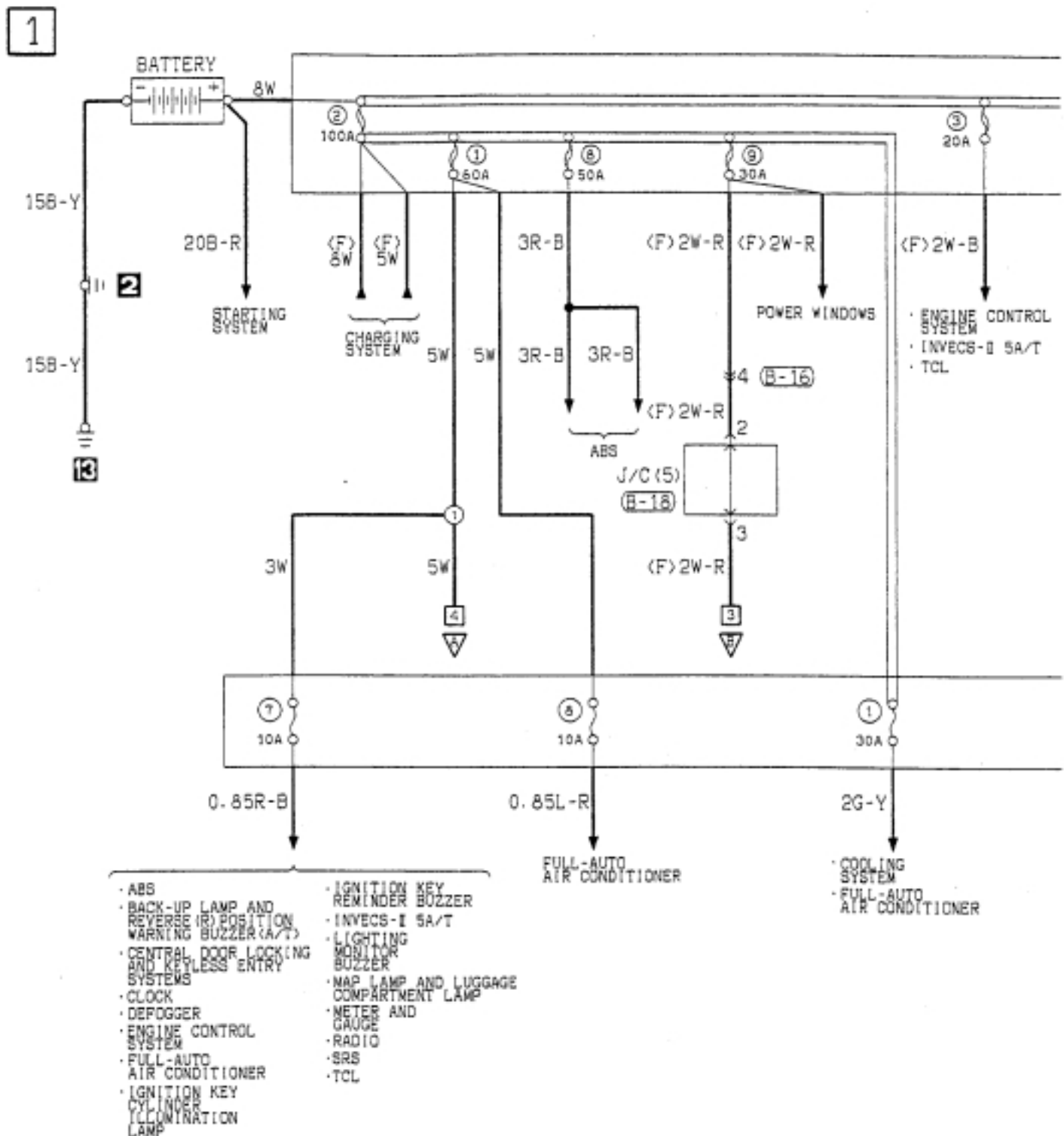

- ABS
- BACK-UP LAMP AND REVERSE (R) POSITION WARNING BUZZER (A/T)
- CENTRAL DOOR LOCKING AND KEYLESS ENTRY SYSTEMS
- CLOCK
- DEFOGGER
- ENGINE CONTROL SYSTEM
- FULL-AUTO AIR CONDITIONER
- IGNITION KEY CYLINDER ILLUMINATION LAMP
- IGNITION KEY REMINDER BUZZER
- INVECS-I 5A/T
- LIGHTING MONITOR BUZZER
- MAP LAMP AND LUGGAGE COMPARTMENT LAMP
- METER AND GAUGE
- RADIO
- SRS
- TCL
- COOLING SYSTEM
- FULL-AUTO AIR CONDITIONER

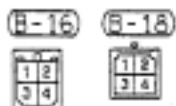

2

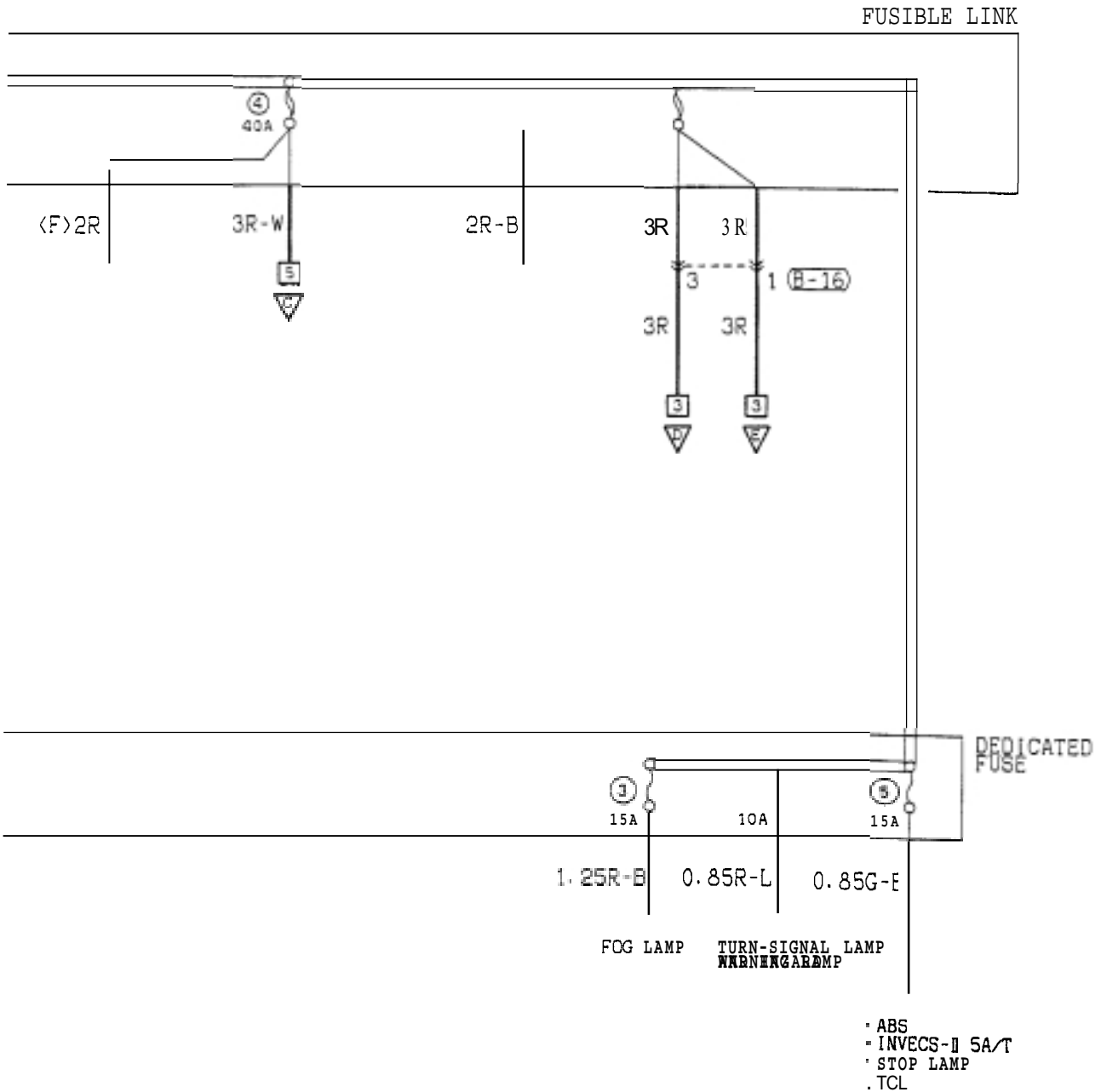

Wire colour code

B : Black	LG : Light green	G : Green	L : Blue	W : White	Y : Yellow	SB : Sky blue
BR : Brown	O : Orange	GR : Gray	R : Red	P : Pink	V : Violet	



POWER DISTRIBUTION SYSTEM (CONTINUED)

3

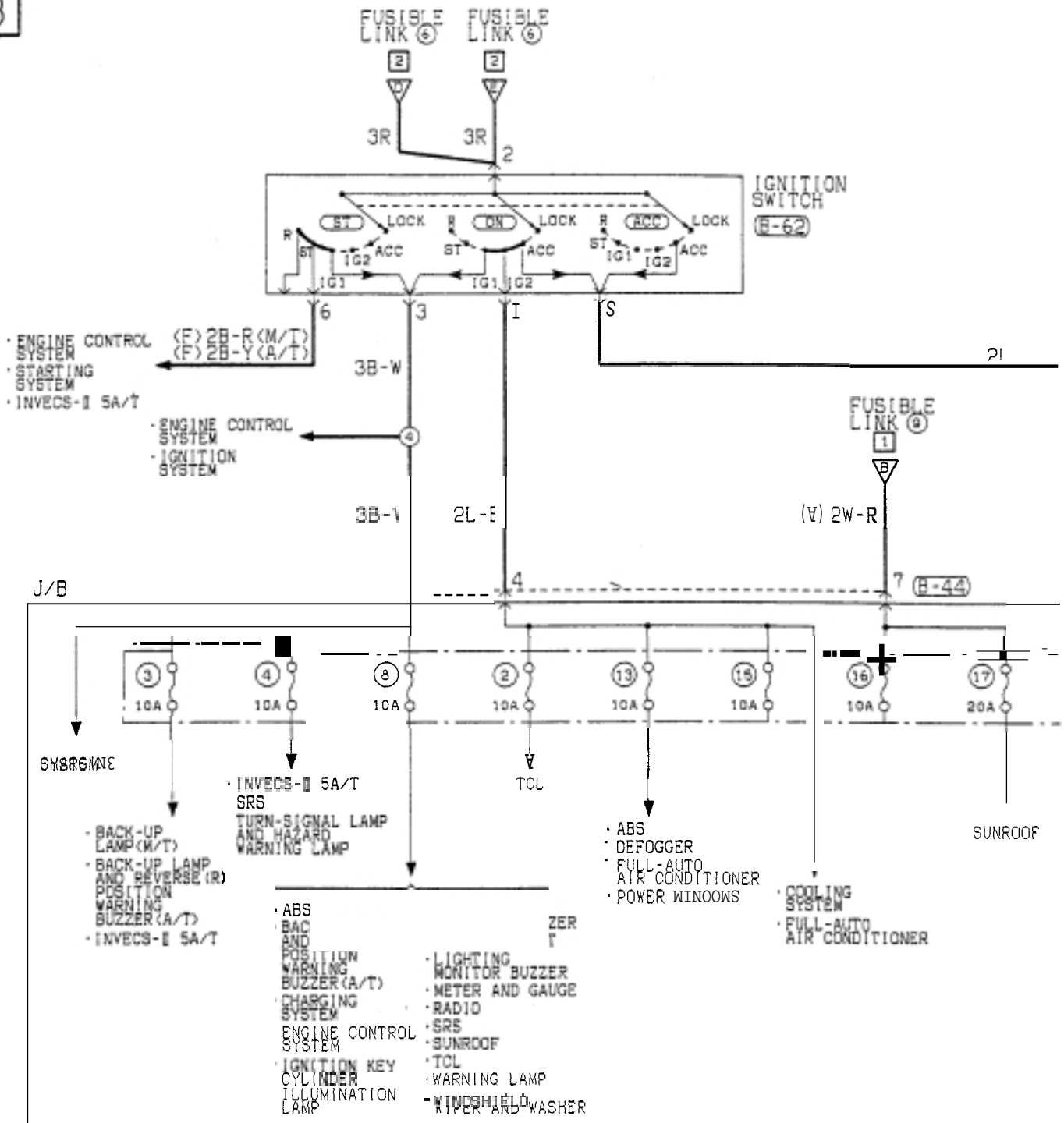

4

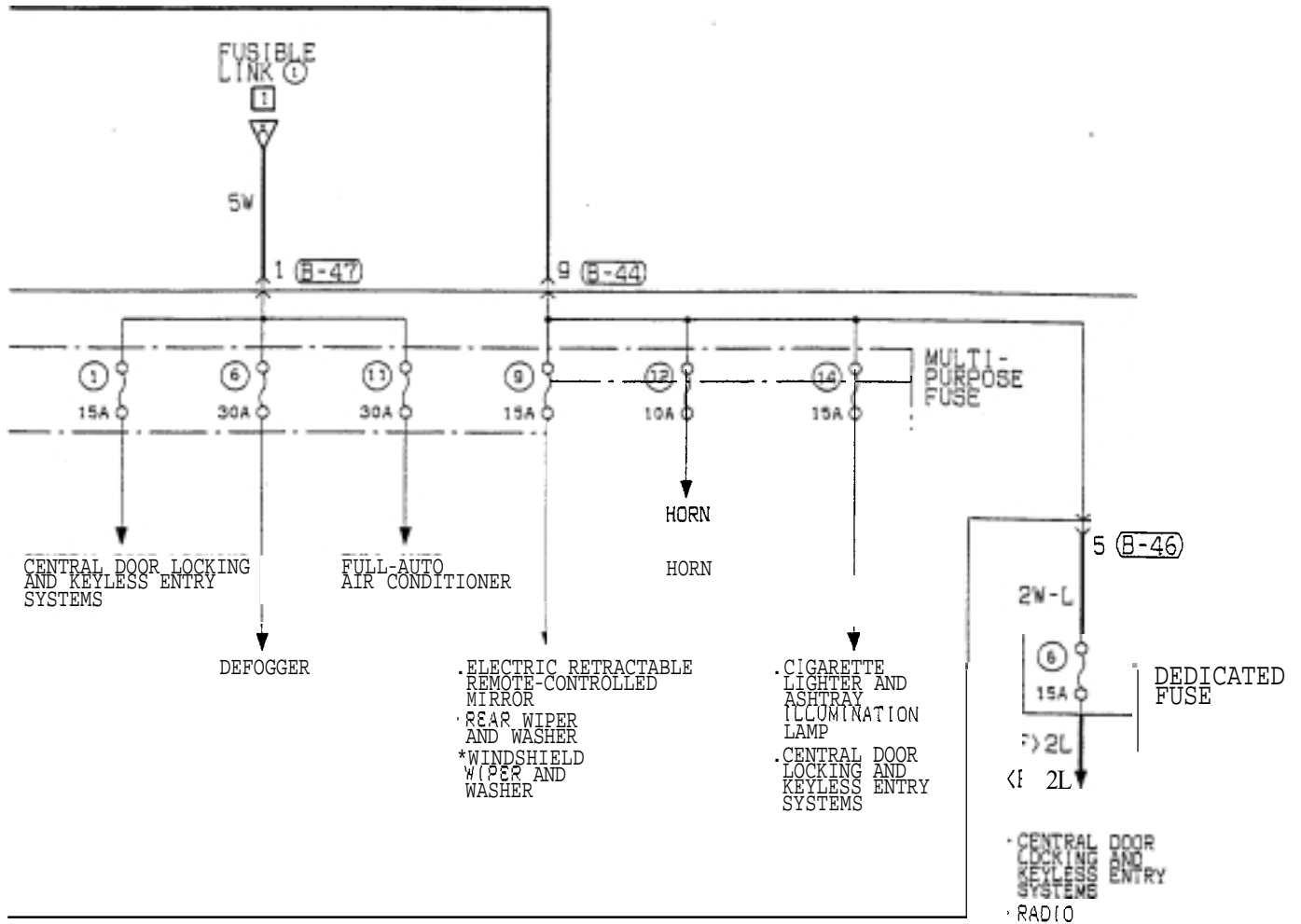

Wire colour code  
 BK:Black LG:Light green G:Green L:Blue W:White Y:Yellow SB:Sky blue  
 BR:Brown O:Orange GR:Gray R:Red P:Pink V:Violet

POWER DISTRIBUTION SYSTEM (CONTINUED)

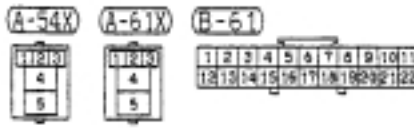
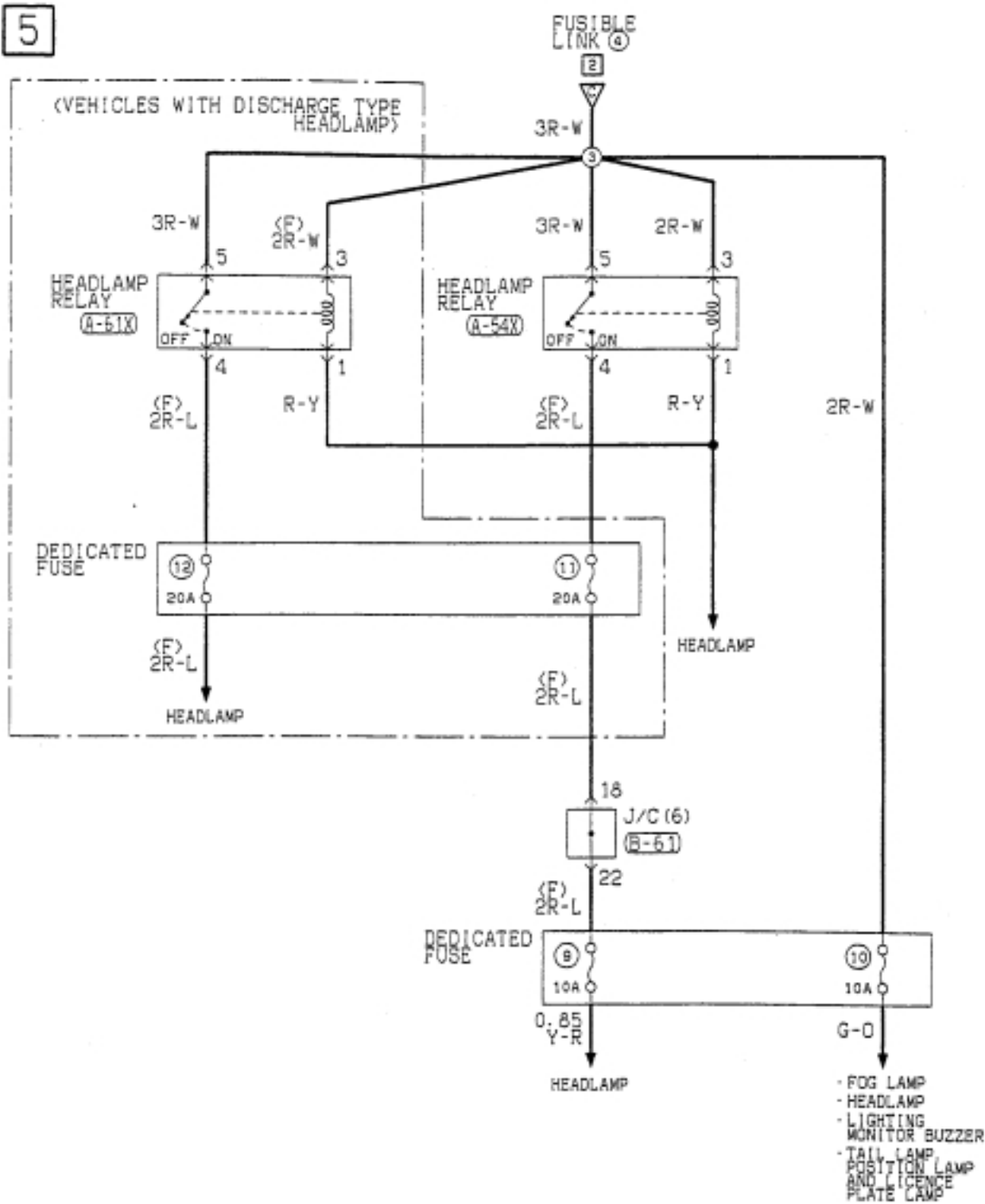

Wire colour code

BL:Black	LG:Light green	G:Green	L:Blue	W:White	Y:Yellow	SB:Sky blue
BR:Brown	O:Orange	GR:Gray	R:Red	P:Pink	V:Violet	

STARTING SYSTEM

1

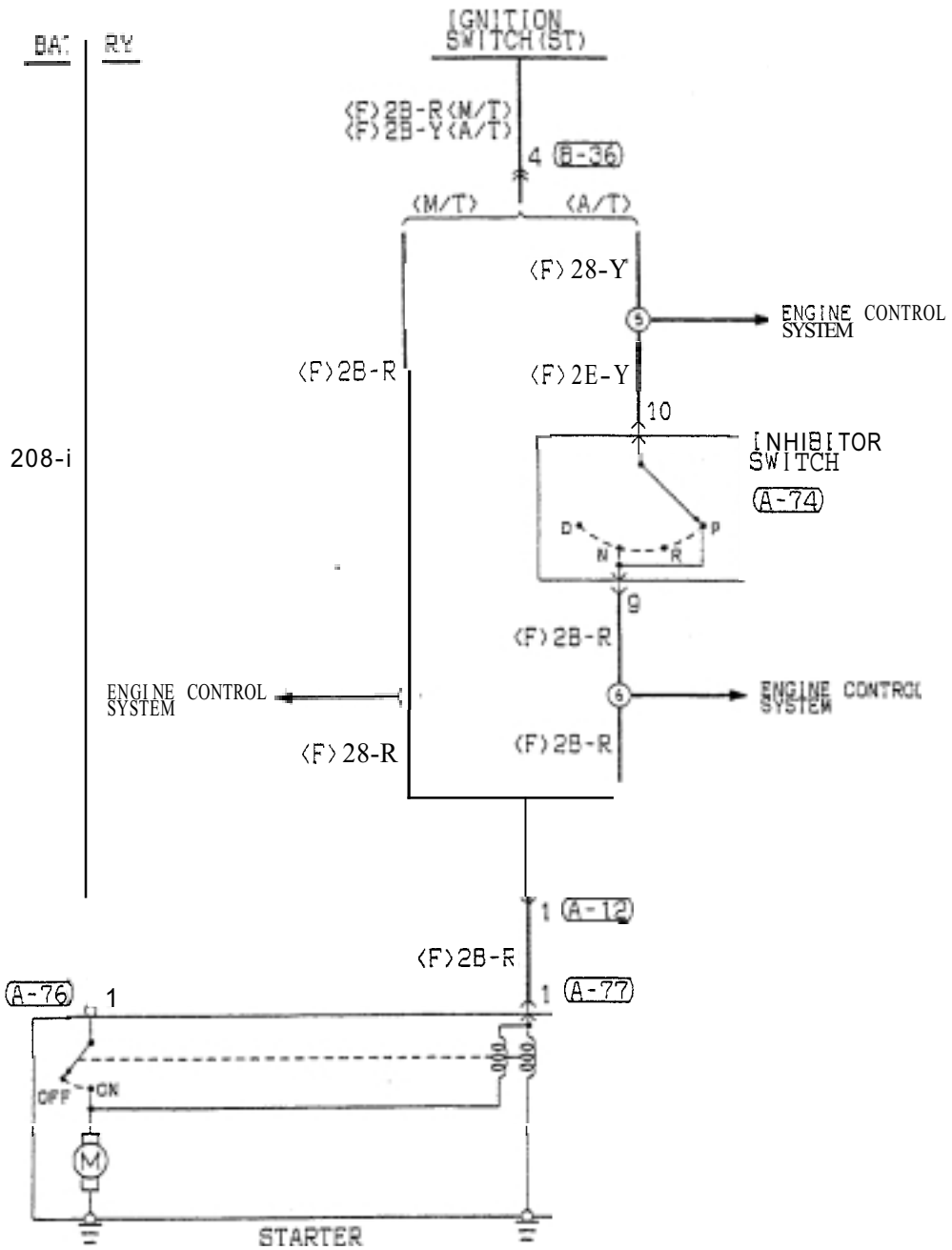

Wire colour code  
 BK:Black LG:Light green G:Green B:Blue W:White Y:Yellow SB:Sky blue  
 BR:Brown O:Orange GR:Gray R:Red P:Pink V:Violet

IGNITION SYSTEM

1

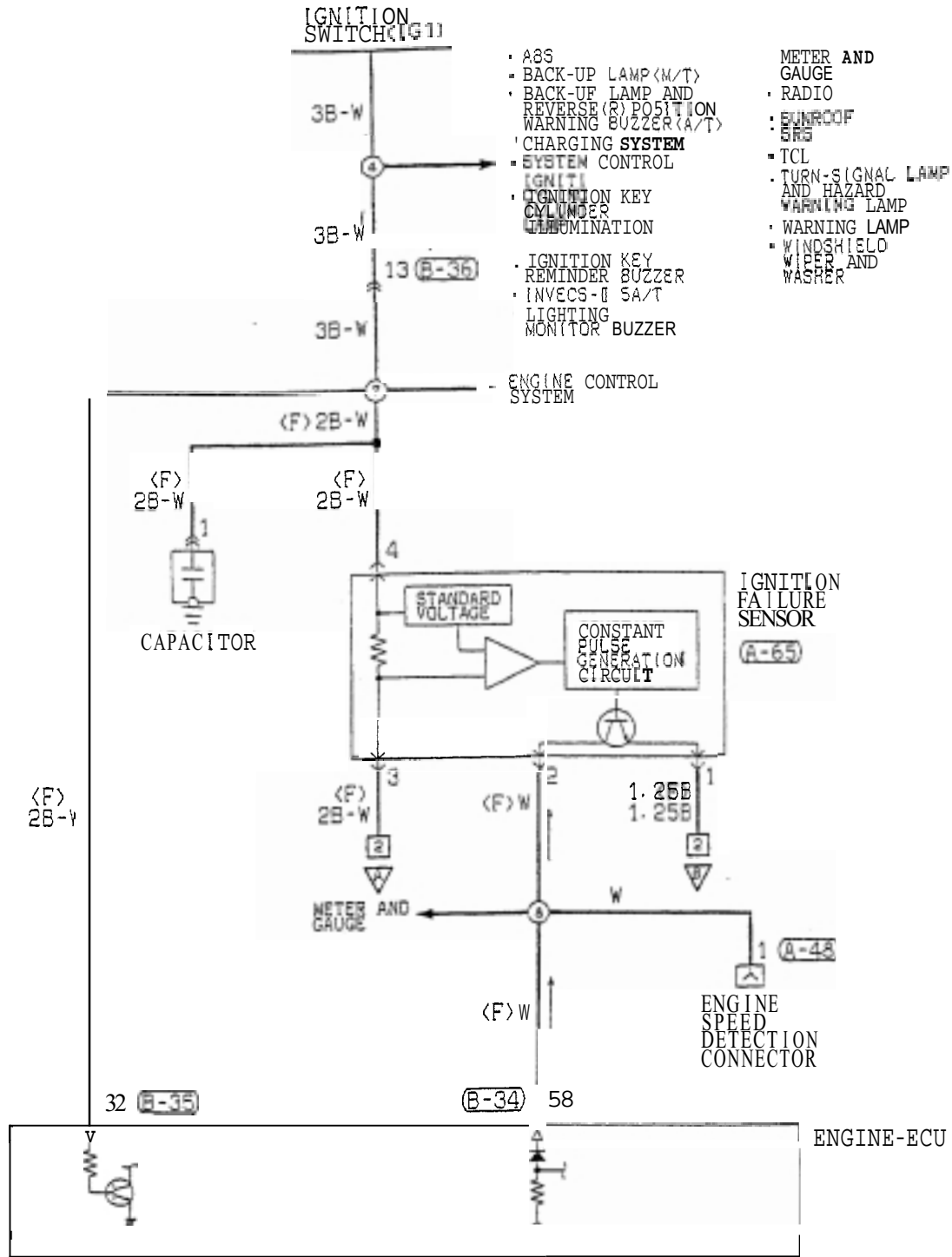

- ABS
- BACK-UP LAMP (M/T)
- BACK-UP LAMP AND REVERSE (R) POSITION WARNING BUZZER (A/T)
- CHARGING SYSTEM
- SYSTEM CONTROL (IGNITI)
- IGNITION KEY CYLINDER ILLUMINATION
- IGNITION KEY REMINDER BUZZER
- INVECS-III SA/T LIGHTING MONITOR BUZZER
- METER AND GAUGE
- RADIO
- SUNROOF
- SRS
- TCL
- TURN-SIGNAL LAMP AND HAZARD WARNING LAMP
- WARNING LAMP
- WINDSHIELD WIPER AND WASHER



2

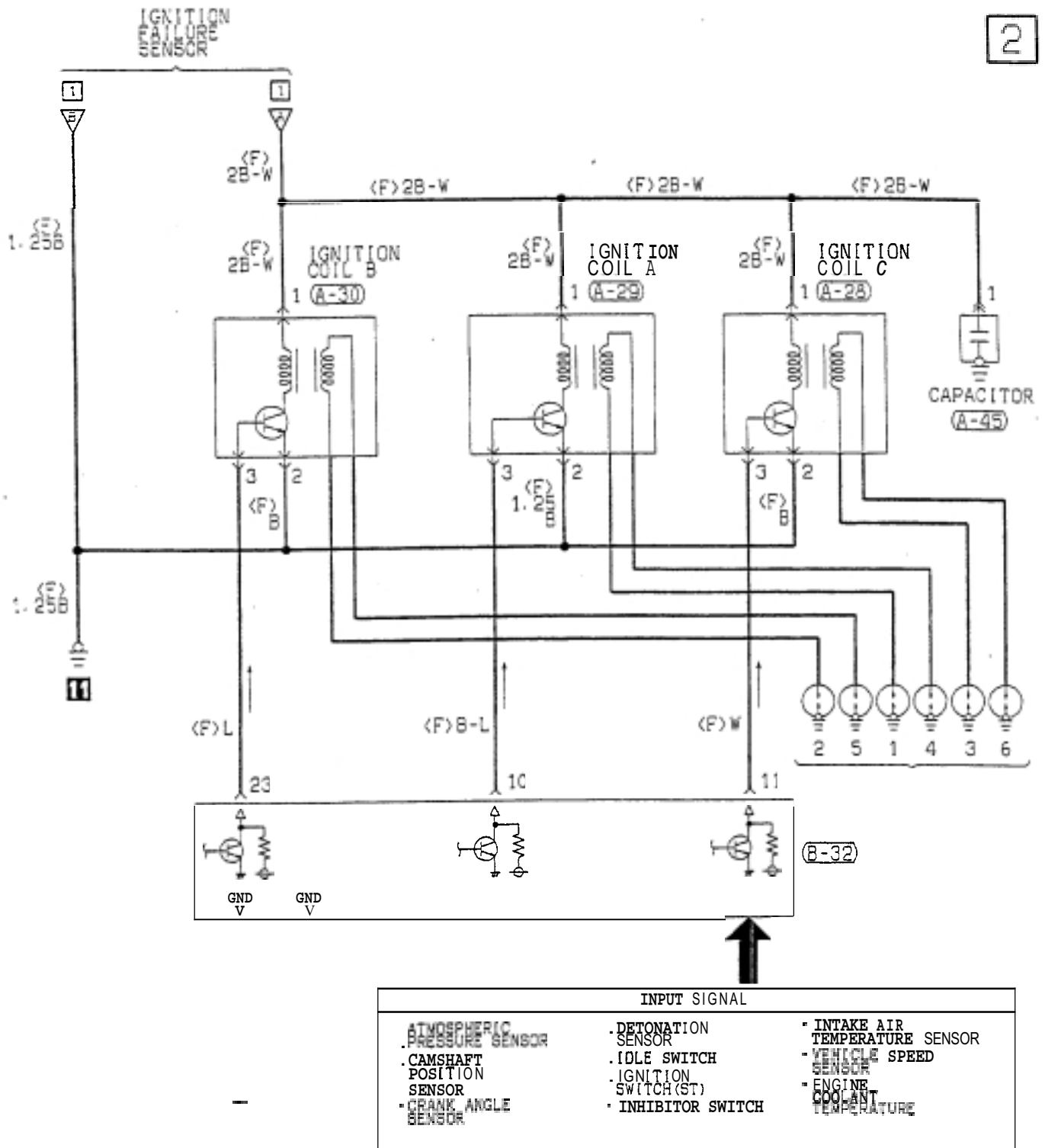

\* Colour code  
 B: Blue G: Green L: Light green R: Red W: White Y: Yellow GB: Sky blue  
 O: Orange GR: Gray P: Pink V: Violet

CHARGING SYSTEM

1

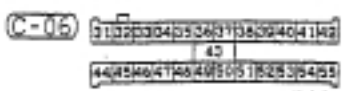
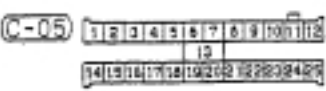
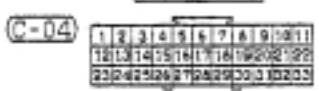
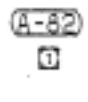
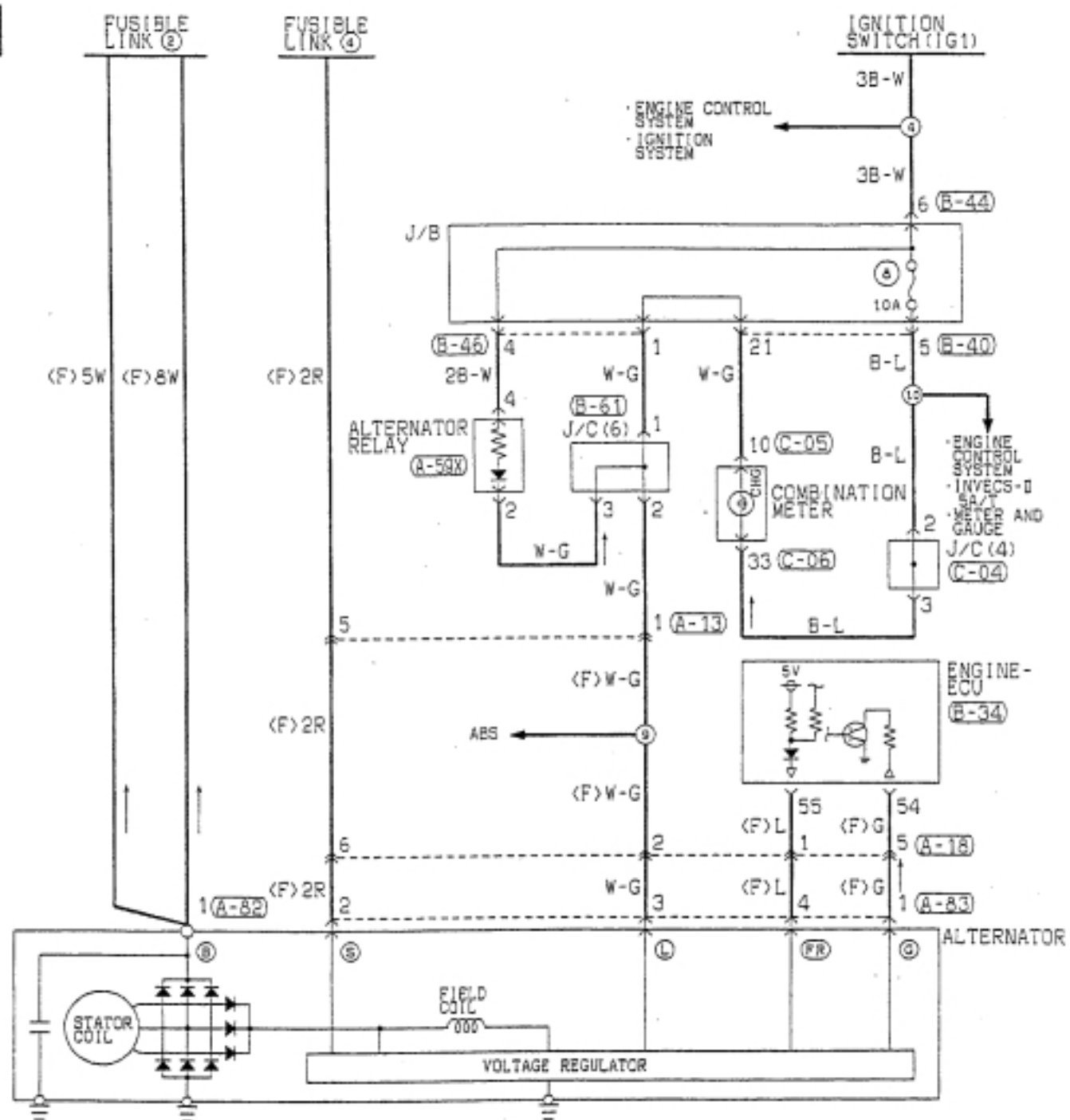

---

NOTES



## ENGINE CONTROL SYSTEM

Vehicles without TCL

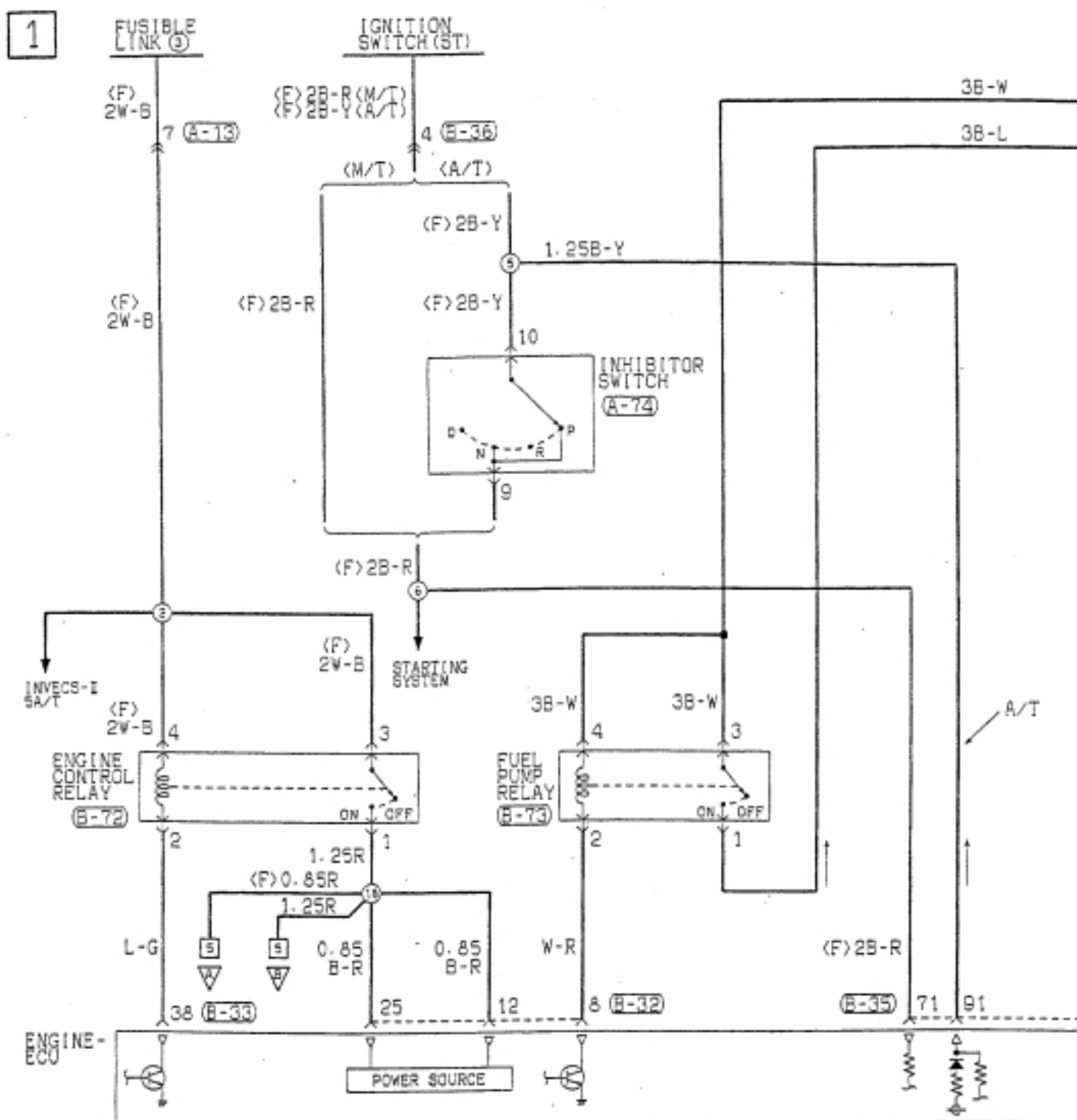

2

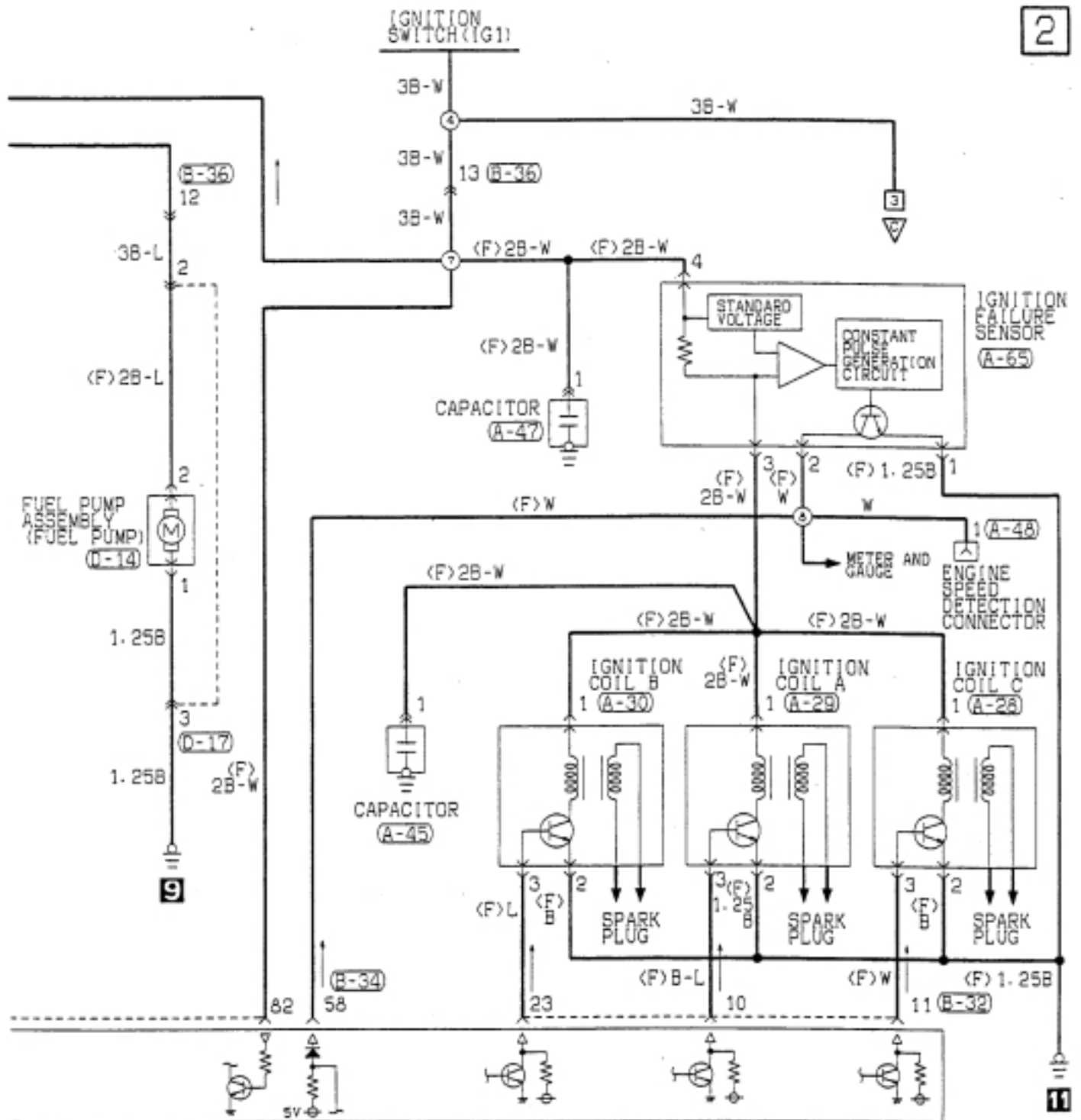

B-32

1	2	3	4	5	6	7	8	9	10	11	12	13
1	4	5	6	7	8	9	10	11	12	13	14	15

B-33

1	2	3	4	5	6	7	8	9	10	11	12	13	14	15
1	4	5	6	7	8	9	10	11	12	13	14	15	16	17

B-34

1	2	3	4	5	6	7	8	9	10	11	12	13	14	15
1	4	5	6	7	8	9	10	11	12	13	14	15	16	17

B-35

1	2	3	4	5	6	7	8	9	10	11	12	13	14	15	16	17	18	19	20
1	4	5	6	7	8	9	10	11	12	13	14	15	16	17	18	19	20	21	22

B-36

1	2	3	4	5	6	7	8	9	10	11	12	13	14	15	16	17	18	19	20
1	4	5	6	7	8	9	10	11	12	13	14	15	16	17	18	19	20	21	22

B-72

1	2	3	4
1	4	5	6

B-73

1	2	3	4
1	4	5	6

Wire colour code  
 LG: Light green G: Green L: Blue W: White Y: Yellow SB: Sky blue  
 BK: Black GR: Gray R: Red P: Pink V: Violet  
 OR: Orange

ENGINE CONTROL SYSTEM  
Vehicles without TCL (CONTINUED)

3

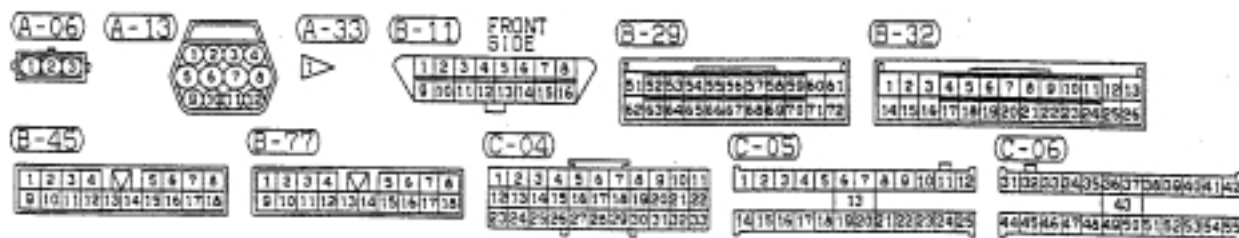
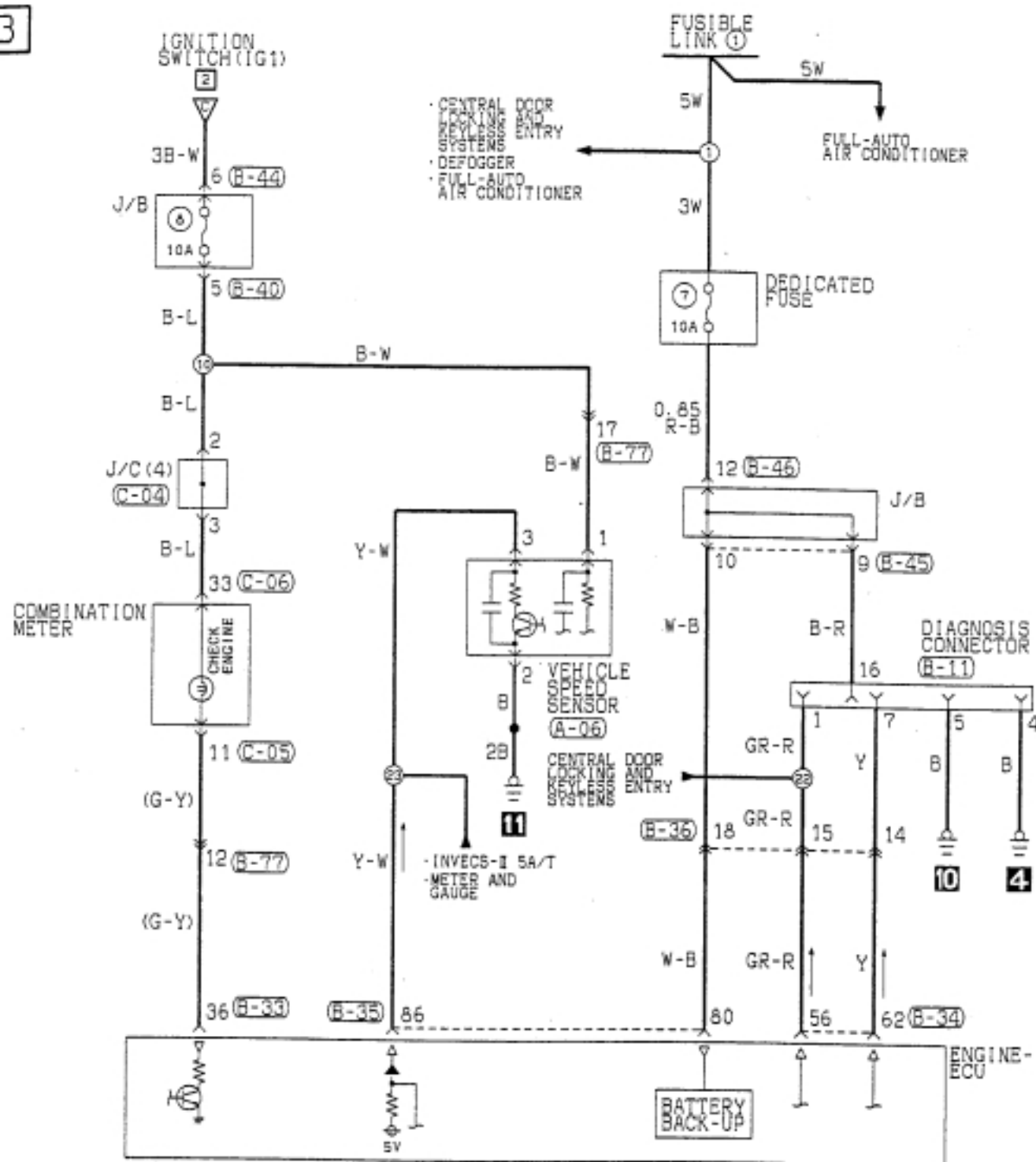

4

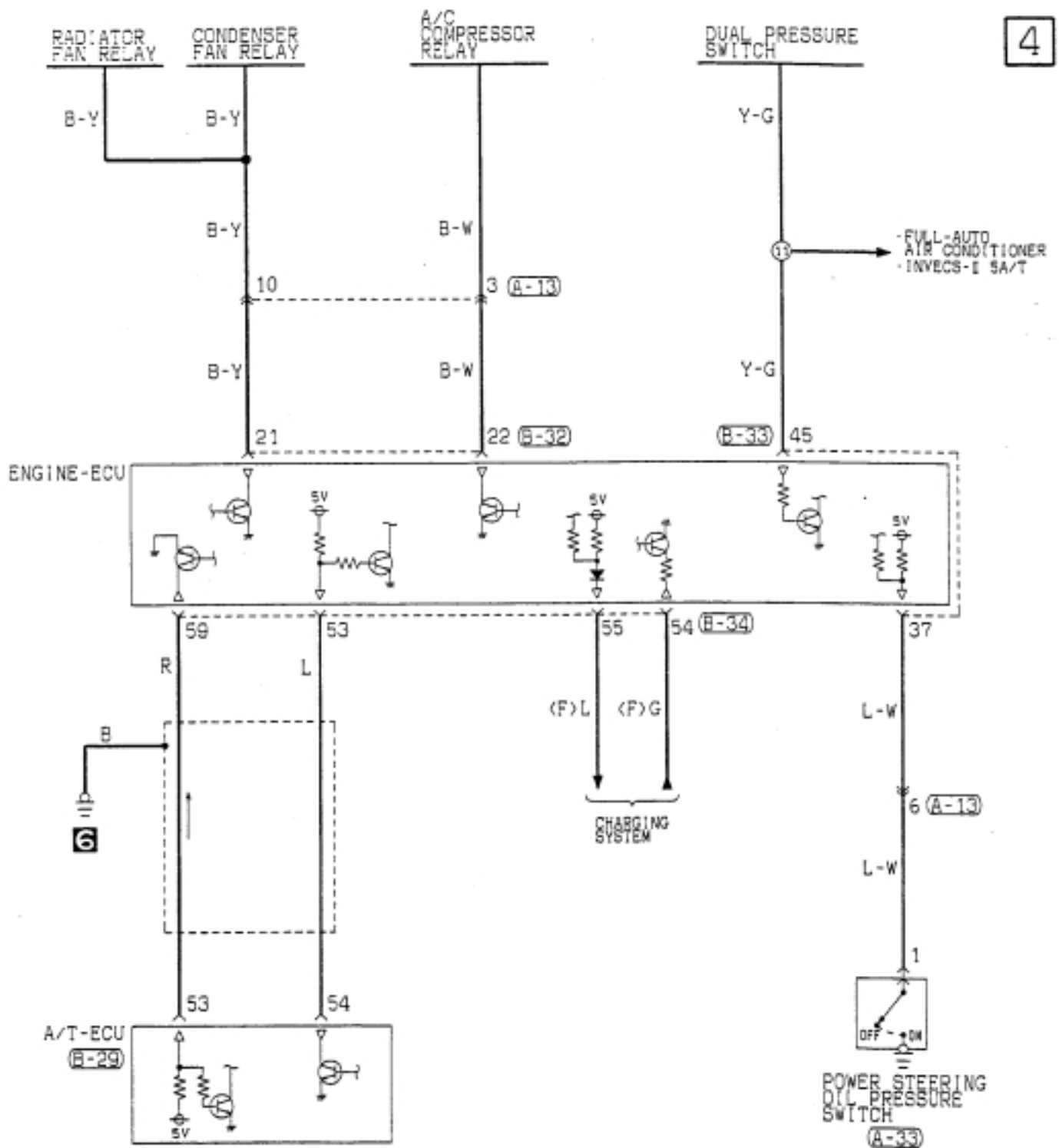

<b>E-33</b>	<b>H-34</b>	<b>B-35</b>	<b>B-36</b>	<b>B-40</b>	<b>B-44</b>
3 1 2 3 4 5 6 7 8 9 10 11 12 13 14 15 16 17 18	1 2 3 4 5 6 7 8 9 10 11 12 13 14 15 16	1 2 3 4 5 6 7 8 9 10 11 12 13 14 15 16 17 18 19 20 21 22 23 24 25 26 27 28 29 30 31 32 33 34 35 36 37 38 39 40 41 42 43 44 45 46 47 48 49 50 51 52 53 54 55 56 57 58 59 60 61 62 63 64 65 66 67 68 69 70 71 72 73 74 75 76 77 78 79 80 81 82 83 84 85 86 87 88 89 90 91 92 93 94 95 96 97 98 99 100	1 2 3 4 5 6 7 8 9 10 11 12 13 14 15 16 17 18	1 2 3 4 5 6 7 8 9 10 11 12 13 14 15 16 17 18 19 20 21 22	1 2 3 4 5 6 7 8 9 10

Wire colour code  
 G:Black LG:Light green G:Green L:Blue W:White Y:Yellow SB:Sky blue  
 BR:Brown O:Orange GR:Gray R:Red P:Pink V:Violet

**ENGINE CONTROL SYSTEM**  
**Vehicles without TCL (CONTINUED)**

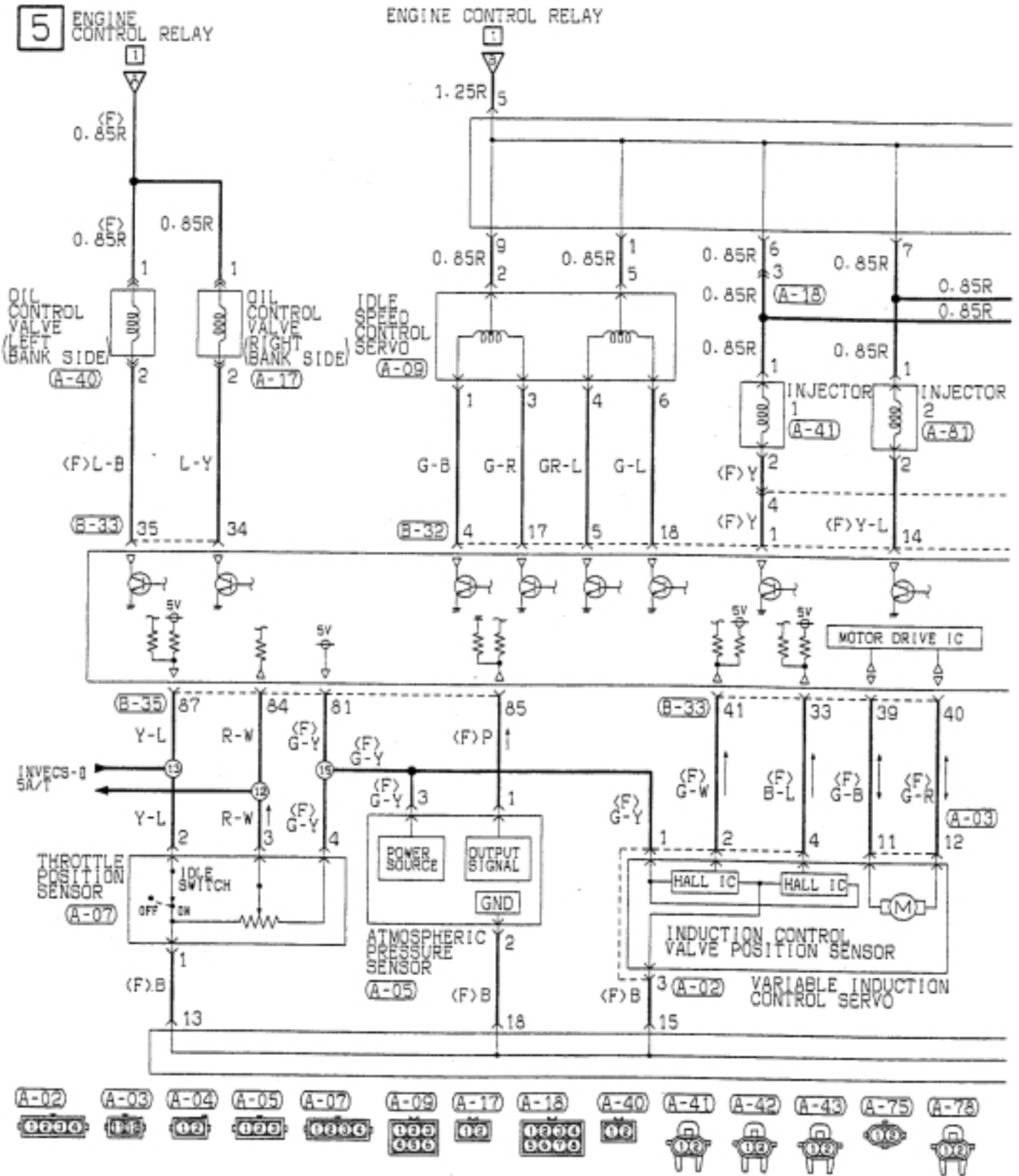

6

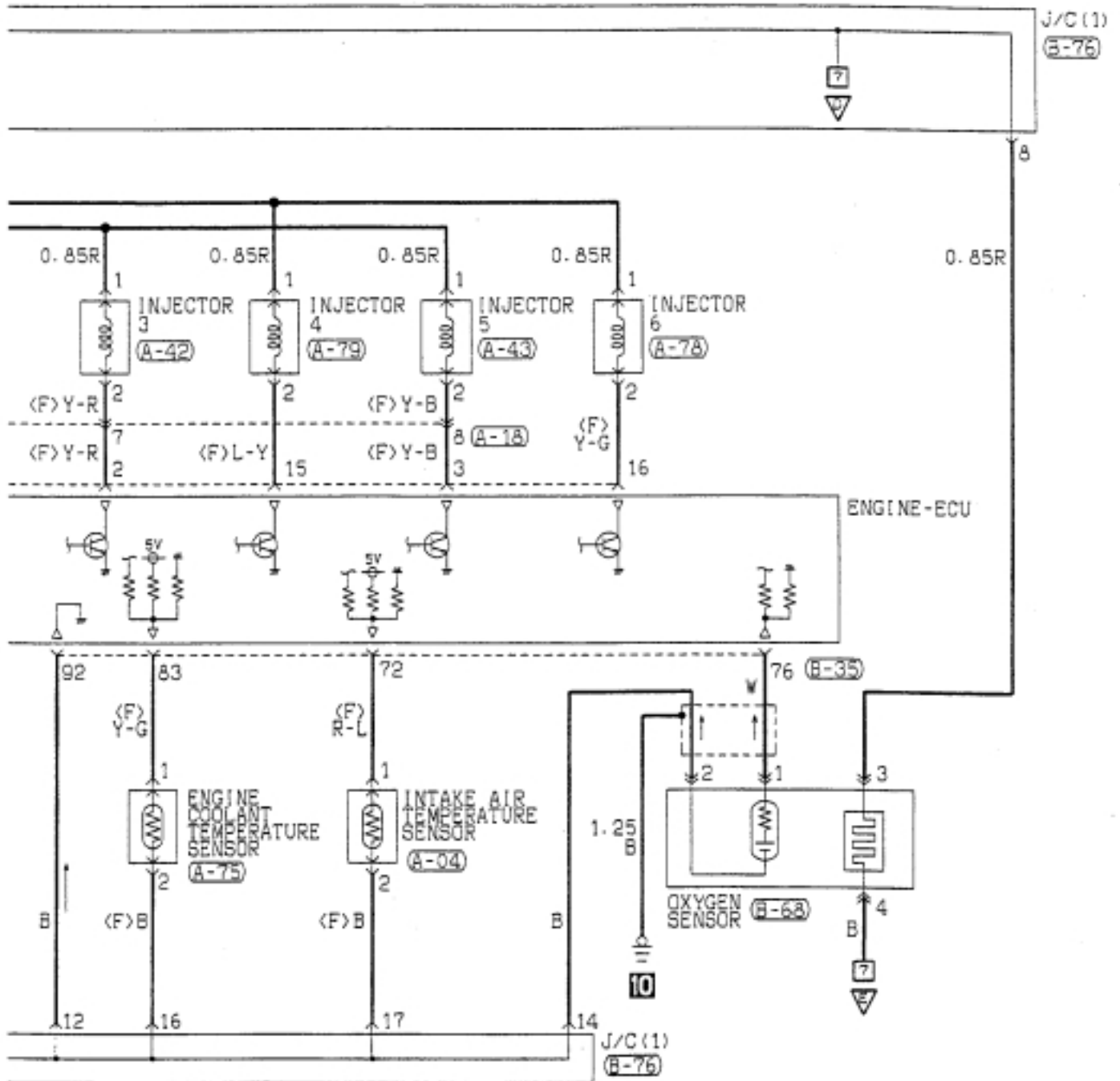

A-79

A-81

B-32

B-33

B-35

B-68

B-76

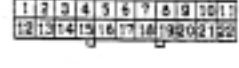

Wire colour code  
 BK:Black LG:Light green G:Green L:Blue W:White Y:Yellow SB:Sky blue  
 BR:Brown O:Orange GR:Gray R:Red P:Pink V:Violet

**ENGINE CONTROL SYSTEM**  
**Vehicles without TCL (CONTINUED)**

7

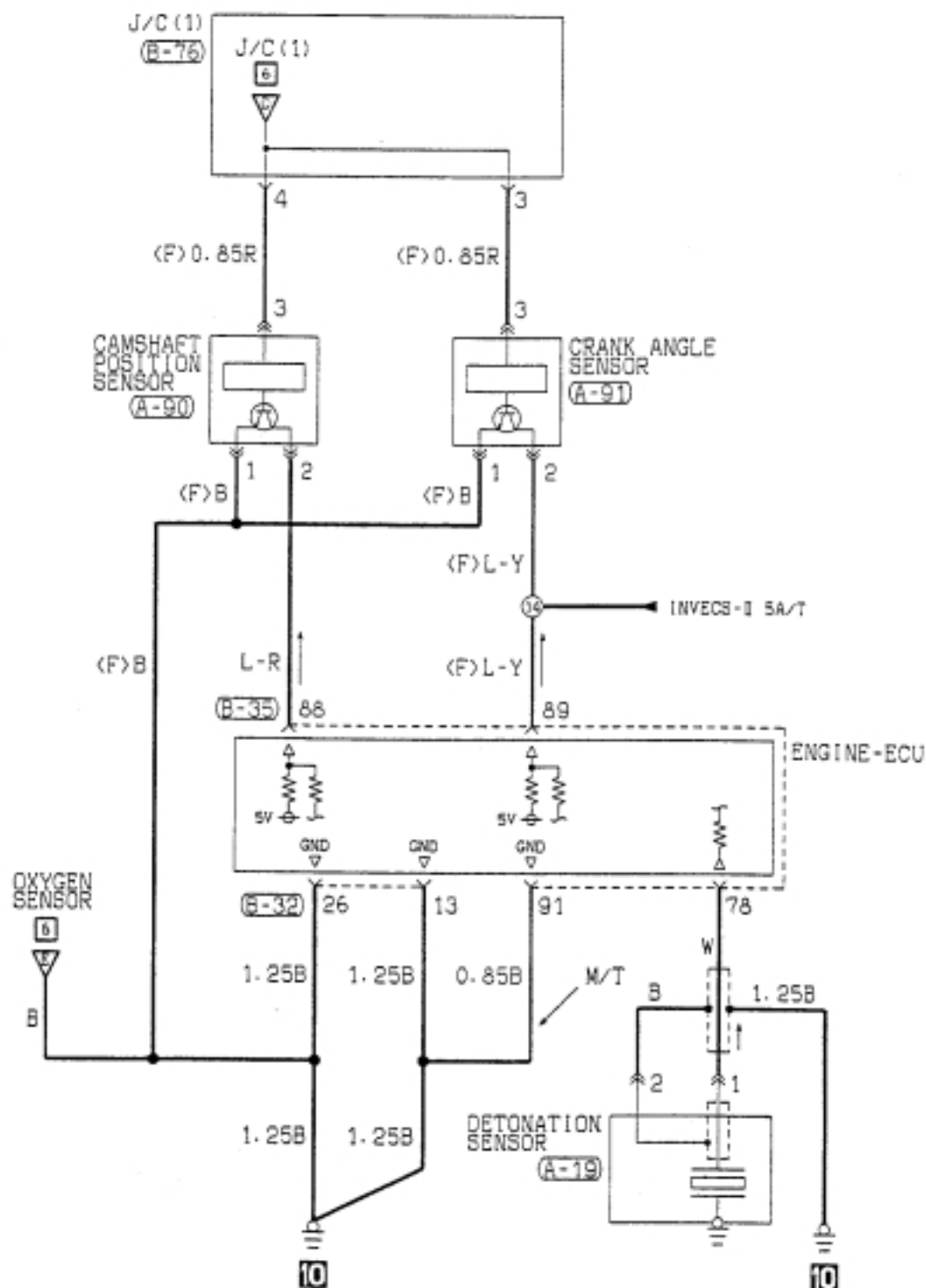
**A-19** **A-90** **A-91** **B-32**

1	2	3	4	5	6	7	8	9	10	11	12	13
14	15	16	17	18	19	20	21	22	23	24	25	26

1	2	3	4	5	6	7	8	9	10	11	12	13
14	15	16	17	18	19	20	21	22	23	24	25	26

**B-35**

1	2	3	4	5	6	7	8	9	10	11	12	13
14	15	16	17	18	19	20	21	22	23	24	25	26

**B-76**

1	2	3	4	5	6	7	8	9	10	11
12	13	14	15	16	17	18	19	20	21	22

Wire colour code

 B : Black    LG : Light green    G : Green    L : Blue    W : White    Y : Yellow    SB : Sky blue  
 BR : Brown    O : Orange    GR : Gray    R : Red    P : Pink    V : Violet

---

NOTES



# ENGINE CONTROL SYSTEM

Vehicles with TCL

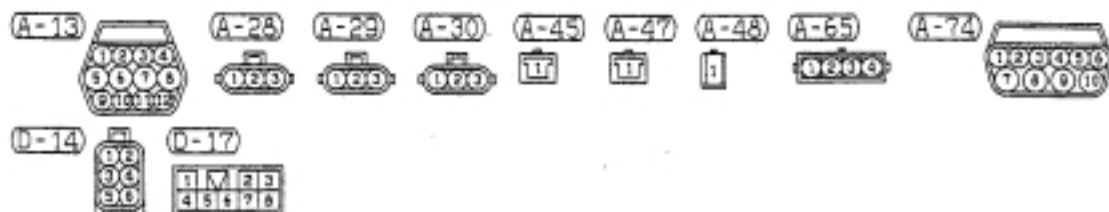
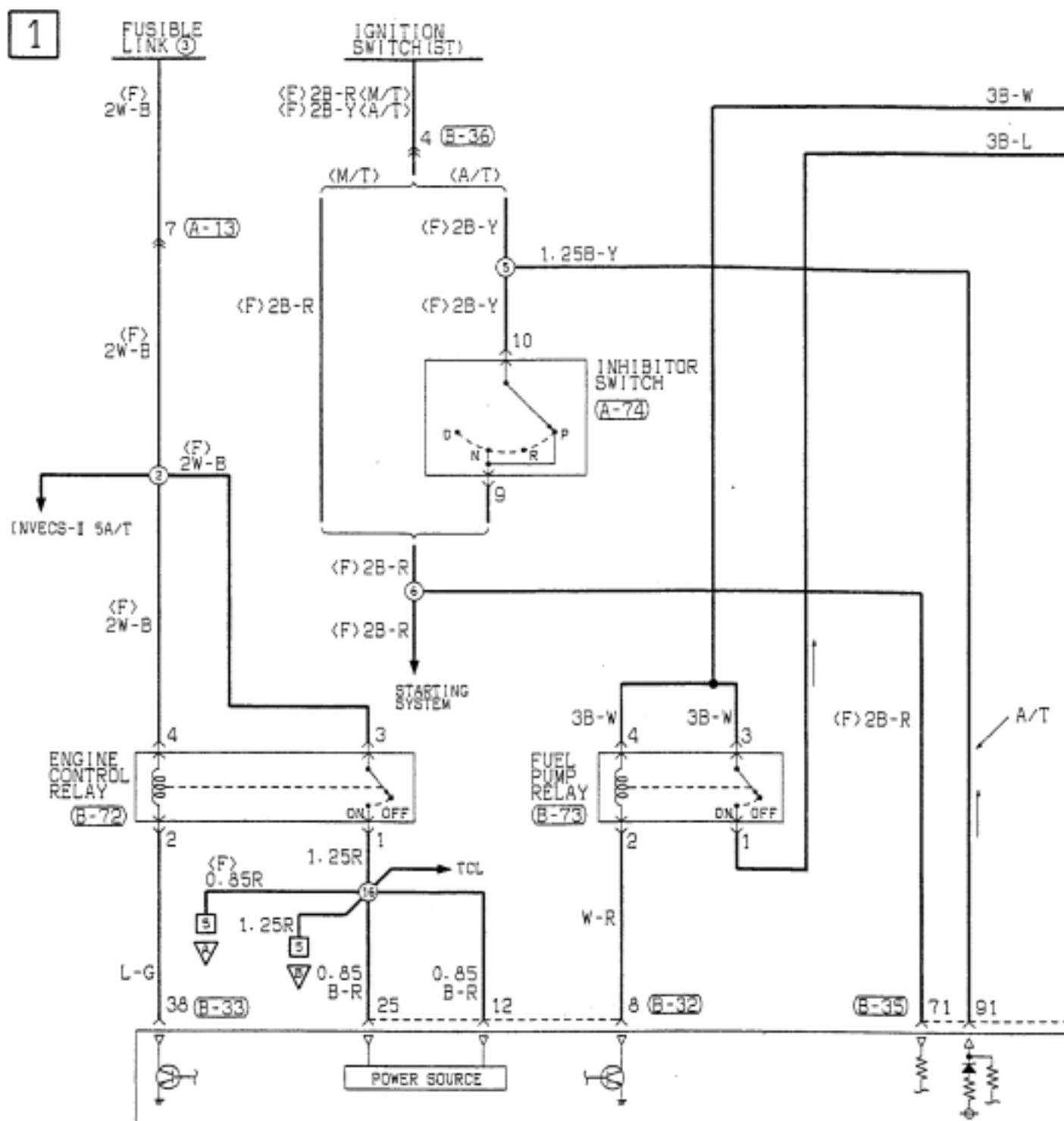

2

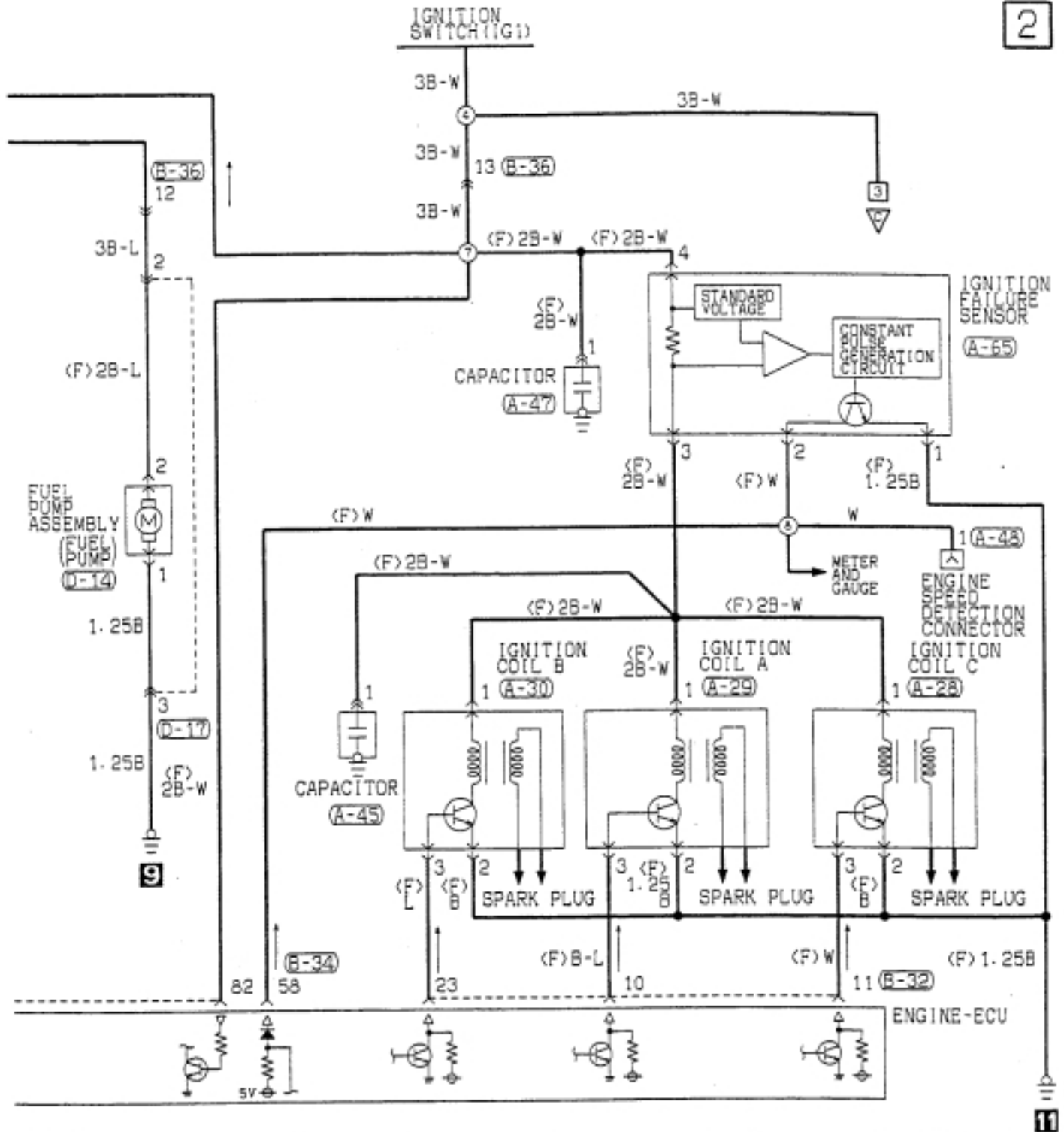

<b>(B-32)</b>	<b>(B-33)</b>	<b>(B-34)</b>	<b>(B-35)</b>	<b>(B-36)</b>	<b>(B-72)</b>	<b>(B-73)</b>
1 2 3 4 5 6 7 8 9 10 11 12 13 14 15 16 17 18 19 20 21 22 23 24 25 26	31 32 33 34 35 36 37 38 39 40 41 42 43 44 45 46	51 52 53 54 55 56 57 58 59 60 61 62	71 72 73 74 75 76 77 78 79 80 81 82 83 84 85 86 87 88 89 90	1 2 3 4 5 6 7 8 9 10 11 12 13 14 15 16 17 18	11 2 3 4	11 2 3 4

Wire colour code  
 BK: Black LG: Light green G: Green L: Blue W: White Y: Yellow SB: Sky blue  
 BR: Brown O: Orange GR: Gray R: Red P: Pink V: Violet

ENGINE CONTROL SYSTEM  
Vehicles with TCL (CONTINUED)

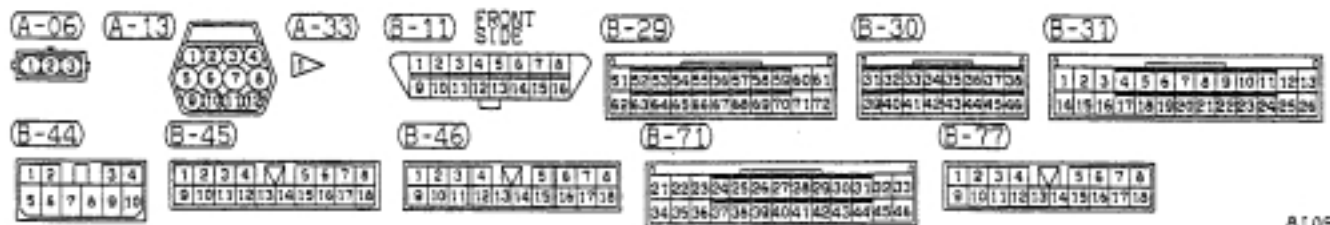
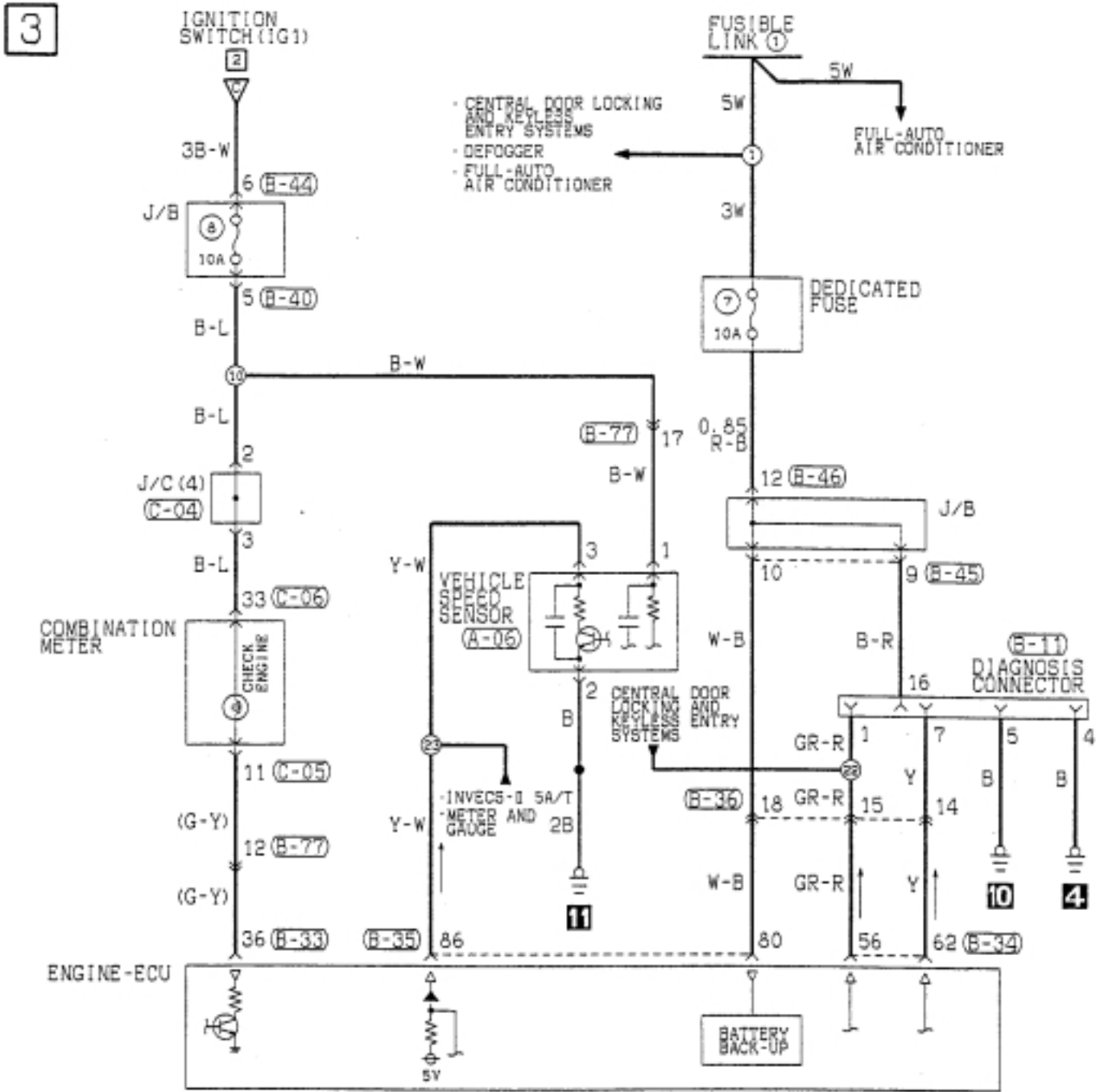

4

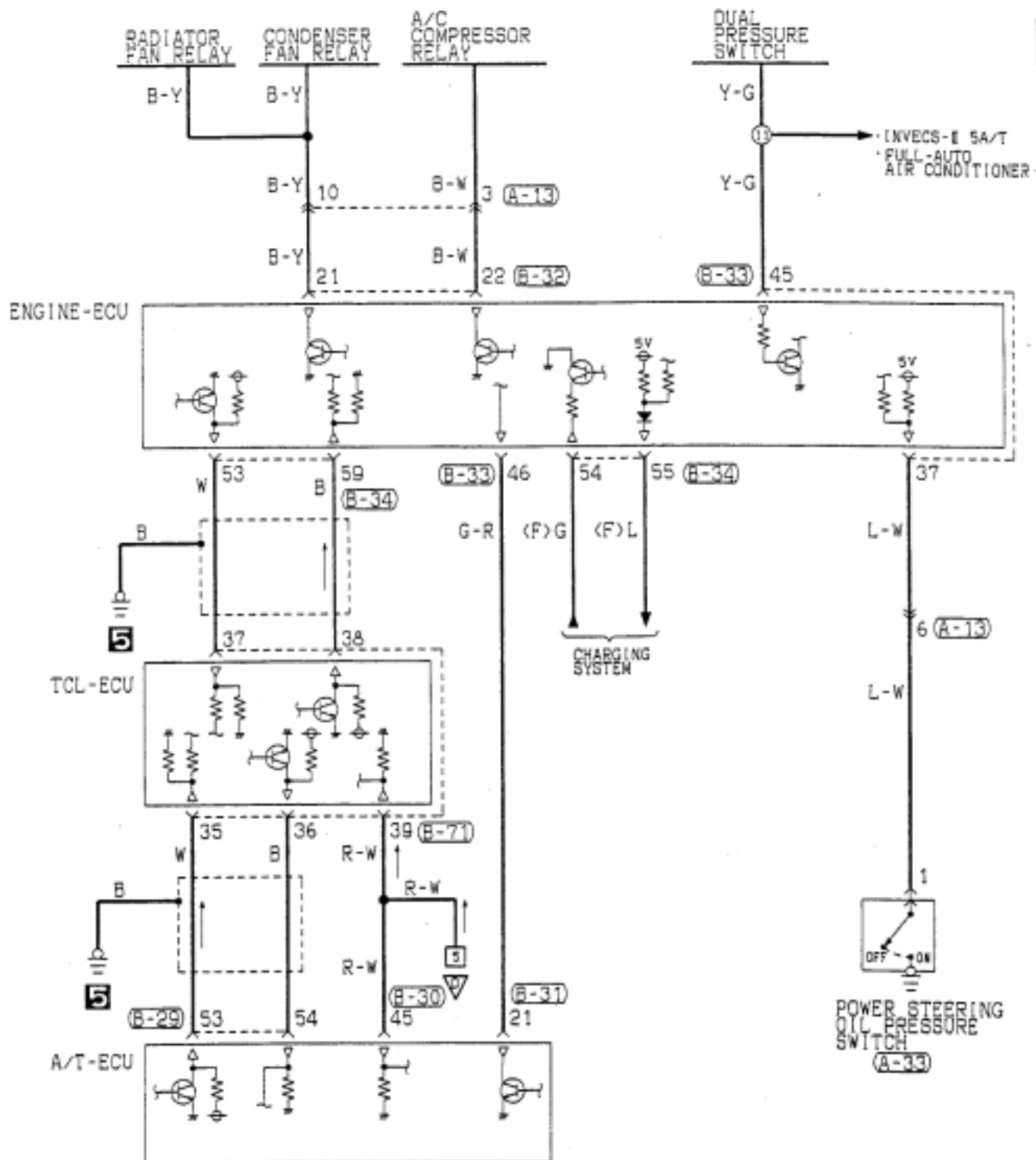

B-32

1	2	3	4	5	6	7	8	9	10	11	12	13
14	15	16	17	18	19	20	21	22	23	24	25	26

B-33

31	32	33	34	35	36	37	38
39	40	41	42	43	44	45	46

B-34

53	54	55	56	57	58
59	60	61	62	63	64

B-35

71	72	73	74	75	76	77	78	79	80	81
82	83	84	85	86	87	88	89	90	91	92

B-36

1	2	3	4	M	5	6	7	8	9	10
11	12	13	14	15	16	17	18	19	20	21

B-40

1	2	3	4	5	M	6	7	8	9	10
11	12	13	14	15	16	17	18	19	20	21

C-04

1	2	3	4	5	6	7	8	9	10	11	12
13	14	15	16	17	18	19	20	21	22	23	24
25	26	27	28	29	30	31	32	33	34	35	36

C-05

1	2	3	4	5	6	7	8	9	10	11	12
13	14	15	16	17	18	19	20	21	22	23	24

C-06

37	38	39	40	41	42	43	44	45	46	47	48	49	50
51	52	53	54	55	56	57	58	59	60	61	62	63	64

ENGINE CONTROL SYSTEM  
Vehicles with TCL (CONTINUED)

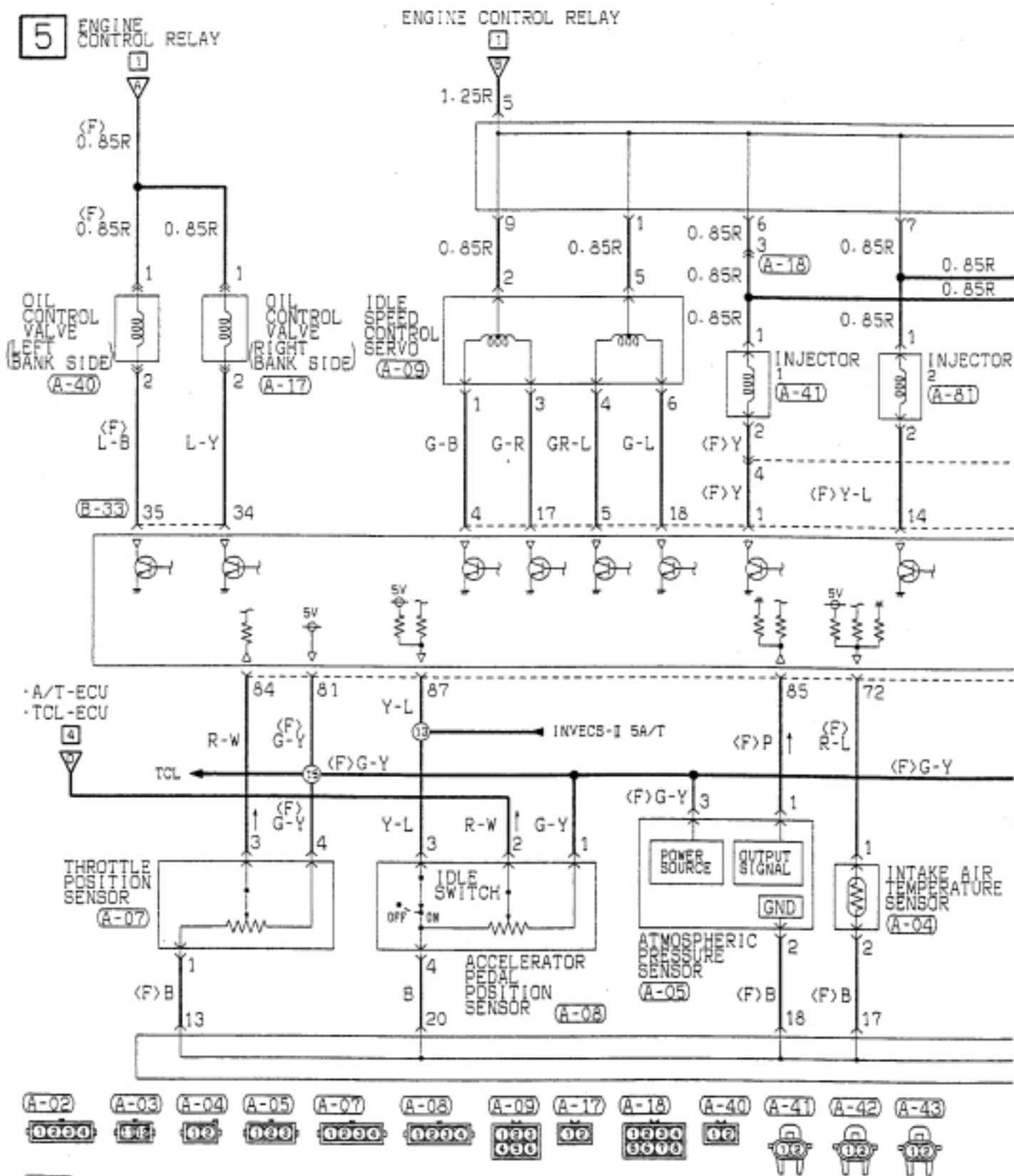

- (A-02)
- (A-03)
- (A-04)
- (A-05)
- (A-07)
- (A-08)
- (A-09)
- (A-17)
- (A-18)
- (A-40)
- (A-41)
- (A-42)
- (A-43)

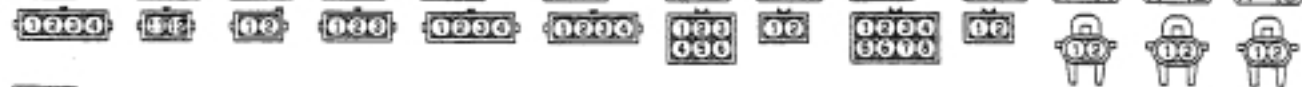

6

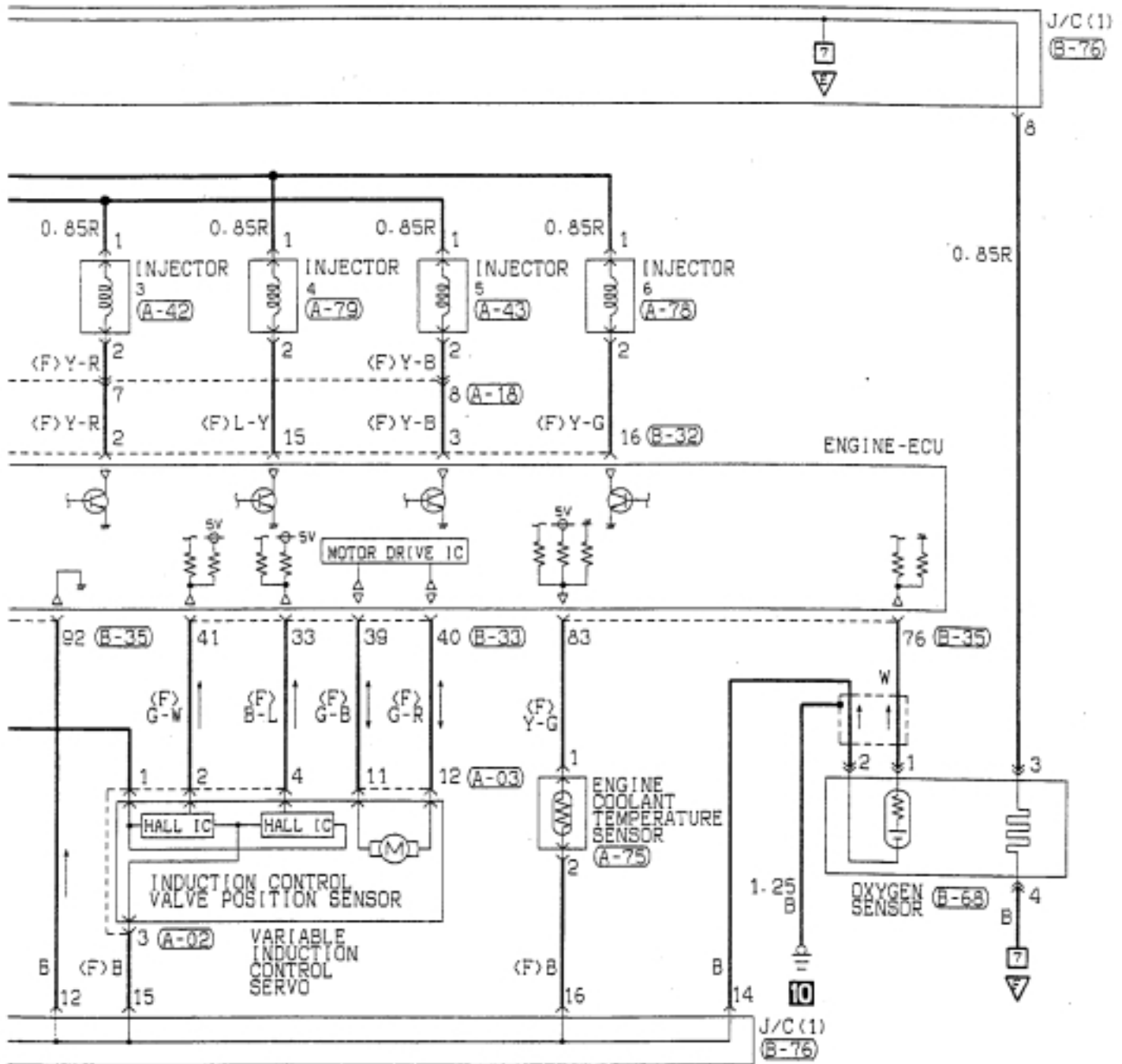

Wire colour code  
 BR: Brown    LG: Light green    G: Green    L: Blue    W: White    Y: Yellow    SB: Sky blue  
 BK: Black    O: Orange    GR: Gray    R: Red    P: Pink    V: Violet

ENGINE CONTROL SYSTEM  
Vehicles with TCL (CONTINUED)

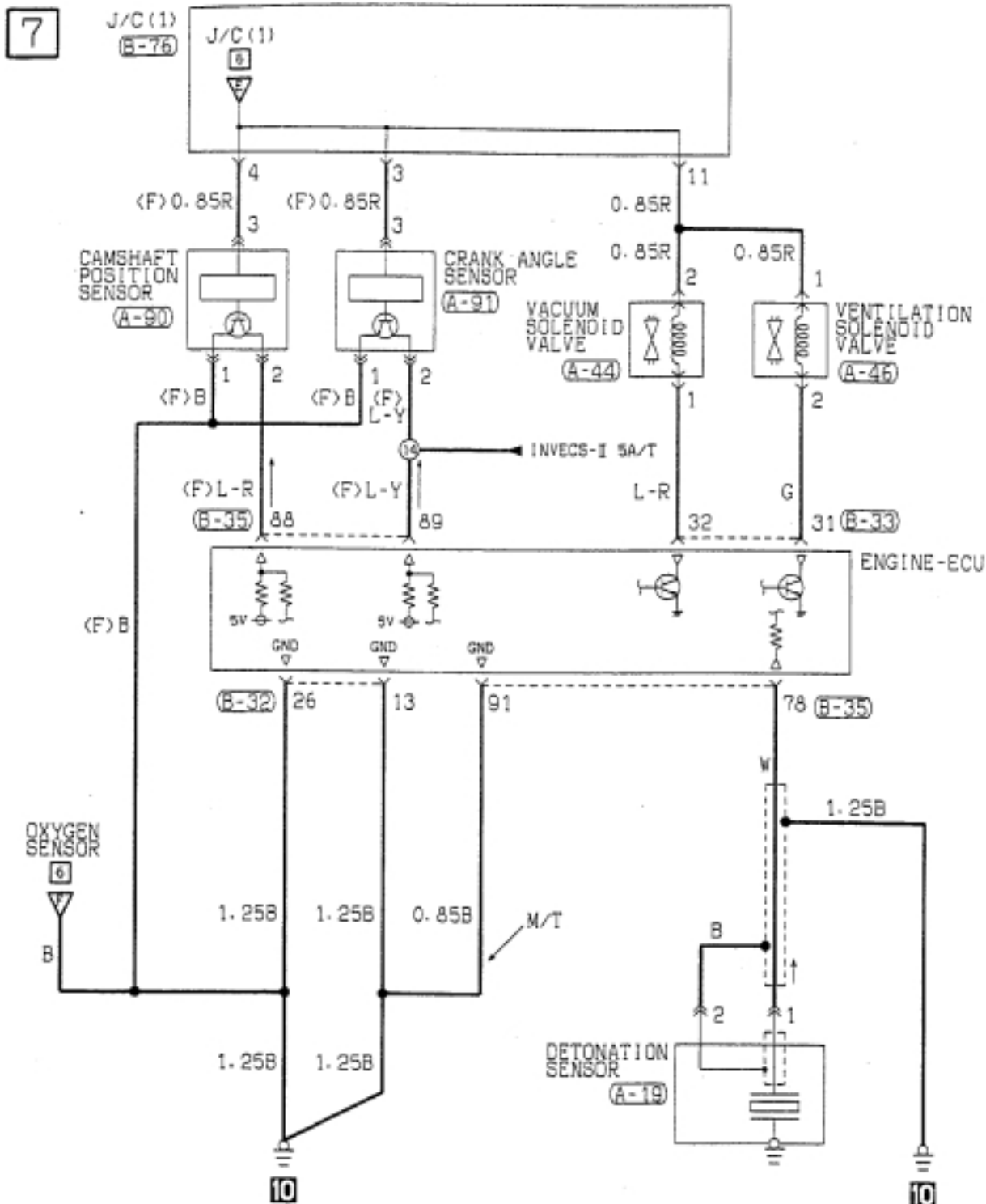

<b>A-19</b>	<b>A-44</b>	<b>A-46</b>	<b>A-90</b>	<b>A-91</b>	<b>B-32</b>	<b>B-33</b>	<b>B-35</b>
00	1	12	000	0	1 2 3 4 5 6 7 8 9 10 11 12 13	3 12 33 34 35 36 37 38	7 12 13 14 15 16 17 18 19 20 21 22
	2				14 15 16 17 18 19 20 21 22 23 24 25 26	33 34 35 36 37 38 39 40	23 24 25 26 27 28 29 30 31 32
<b>B-76</b>	Wire colour code B: Black LG: Light green G: Green L: Blue BR: Brown O: Orange GR: Gray R: Red W: White SB: Sky blue P: Pink Y: Yellow V: Violet						

COOLING SYSTEM

1

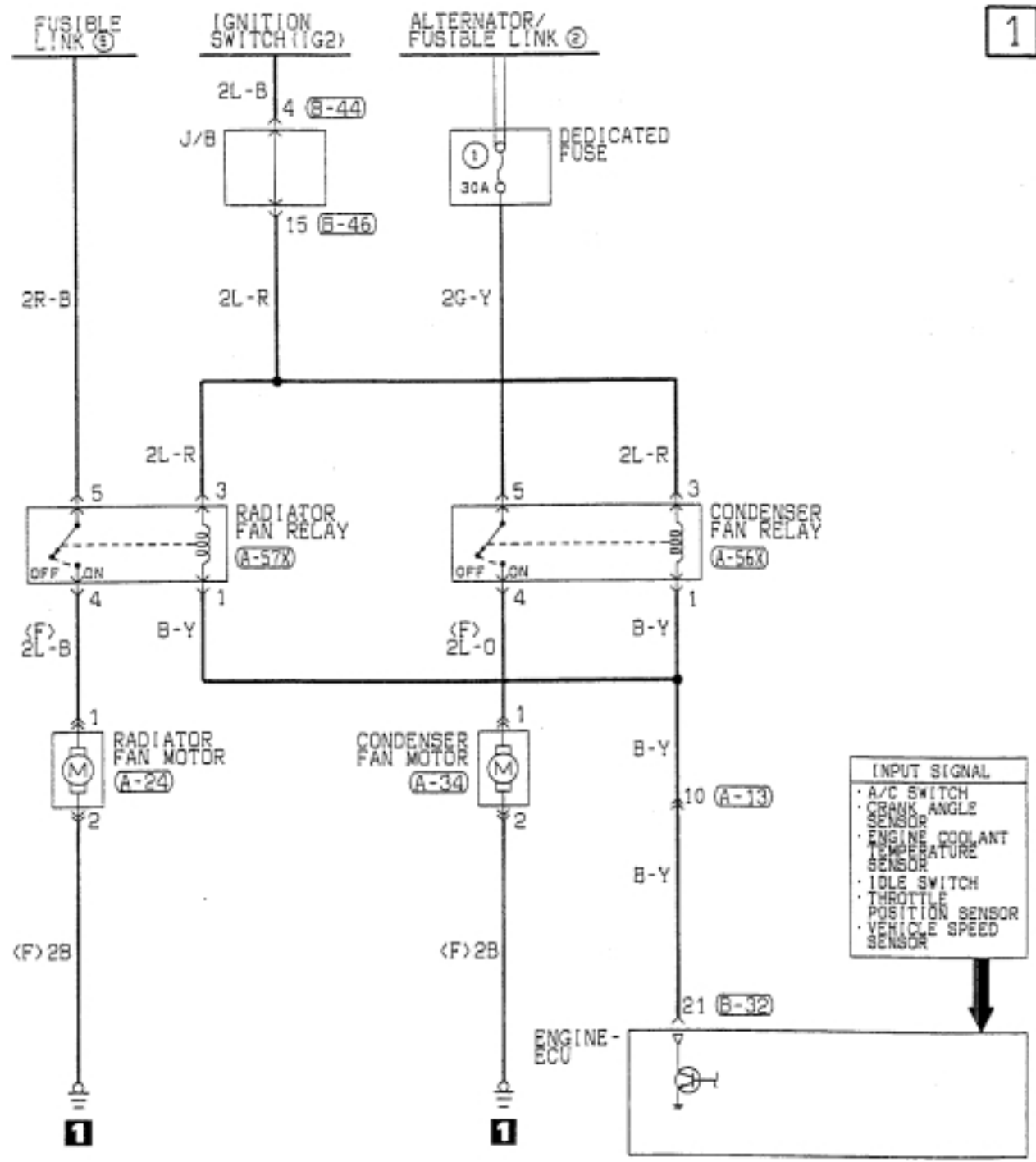



INVECS-II 5A/T

Vehicles without TCL

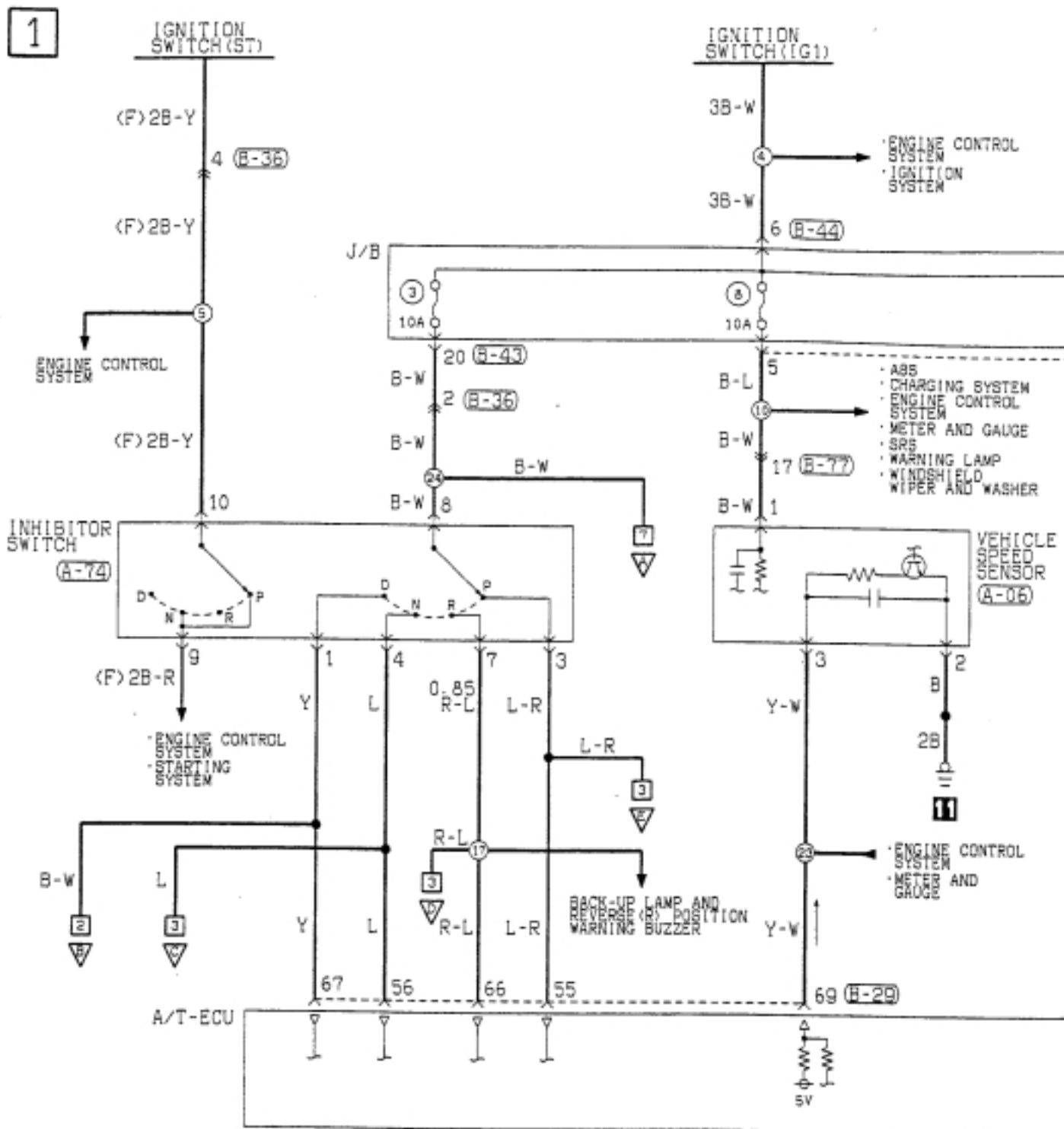

A-06	A-74	B-14	B-17	B-22	B-29	B-31
0 0 0	0 0 0 0 0 0 0 0 0 0	1 2 3 4 5 6 7 8 9 10 11 12 13 14 15 16 17 18 19 20 21 22 23 24 25 26 27 28 29 30 31 32 33	1 2 3 4 5 6 7 8 9 10 11 12 13 14 15 16 17 18	1 2	0 1 2 3 4 5 6 7 8 9 10 11 12 13 14 15 16 17 18 19 20 21 22 23 24 25 26 27 28 29 30 31 32 33 34 35 36 37 38 39 40 41 42 43 44 45 46 47 48 49 50 51 52 53 54 55 56 57 58 59 60 61 62 63 64 65 66 67 68 69 70 71 72	1 2 3 4 5 6 7 8 9 10 11 12 13 14 15 16 17 18 19 20 21 22 23 24 25 26 27 28 29 30 31 32 33 34 35 36 37 38 39 40 41 42 43 44 45 46 47 48 49 50 51 52 53 54 55 56 57 58 59 60 61 62 63 64 65 66 67 68 69 70 71 72
B-77	B-78	C-04				
0 1 2 3 4 5 6 7 8 9 10 11 12 13 14 15 16 17 18	0 1 2 3 4 5 6 7 8 9 10	1 2 3 4 5 6 7 8 9 10 11 12 13 14 15 16 17 18 19 20 21 22 23 24 25 26 27 28 29 30 31 32 33				

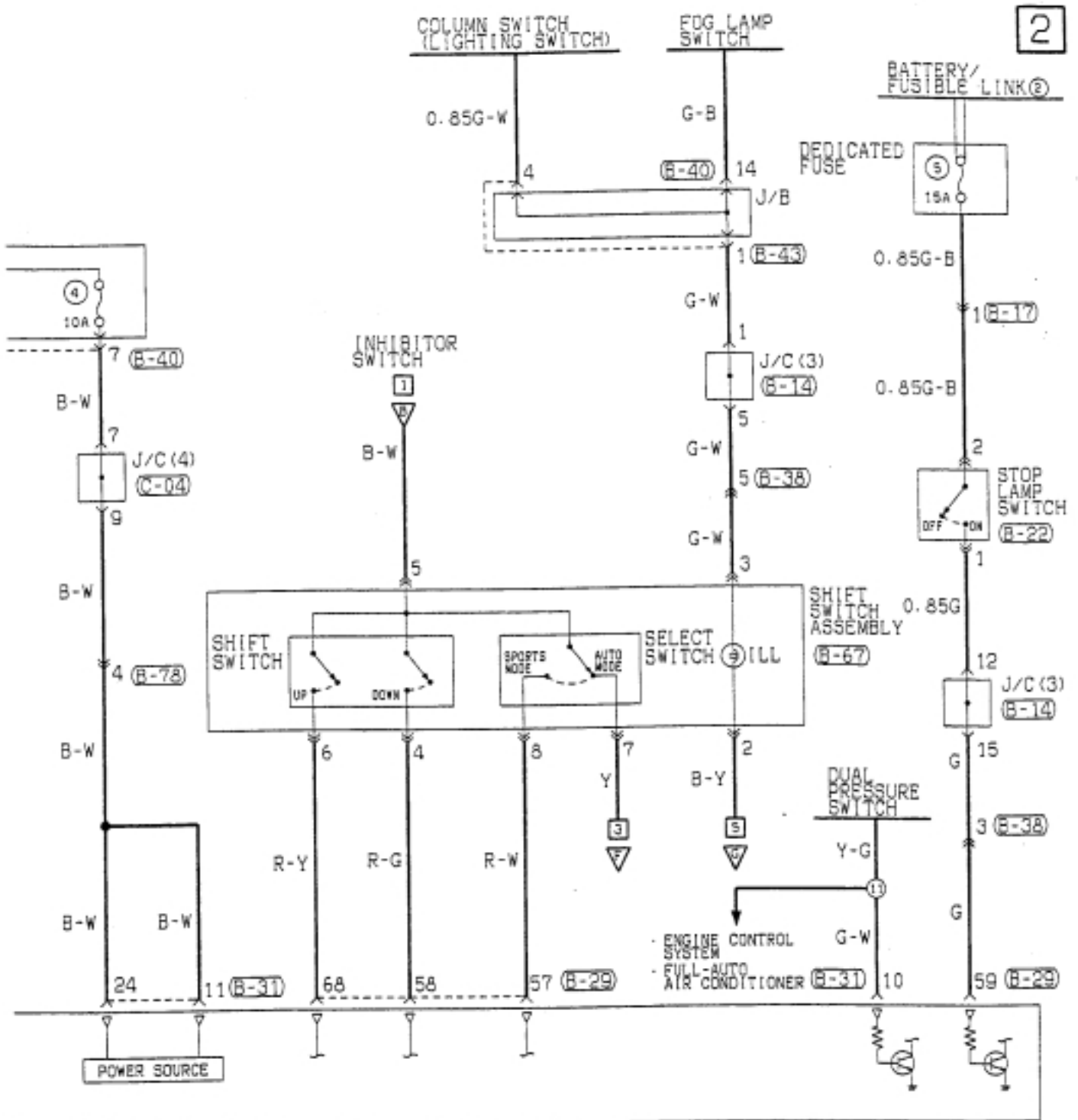

2

B-36

1	2	3	4	5	6	7	8	9	10	11	12	13	14	15	16	17	18
19	20	21	22	23	24	25	26	27	28	29	30	31	32	33	34	35	36

B-38

1	2	3	4	5	6	7	8
---	---	---	---	---	---	---	---

B-40

1	2	3	4	5	6	7	8	9	10	11	12	13	14	15	16	17	18	19	20	21	22
---	---	---	---	---	---	---	---	---	----	----	----	----	----	----	----	----	----	----	----	----	----

B-43

1	2	3	4	5	6	7	8	9	10	11	12	13	14	15	16	17	18	19	20	21	22
---	---	---	---	---	---	---	---	---	----	----	----	----	----	----	----	----	----	----	----	----	----

B-44

1	2	3	4	5	6	7	8	9	10
---	---	---	---	---	---	---	---	---	----

B-67

1	2	3	4	5	6	7	8
---	---	---	---	---	---	---	---

Wire colour code  
 BK: Black LG: Light green G: Green L: Blue W: White Y: Yellow SB: Sky blue  
 BR: Brown O: Orange GR: Gray R: Red P: Pink V: Violet

INVECS-II 5A/T  
Vehicles without TCL (CONTINUED)

3

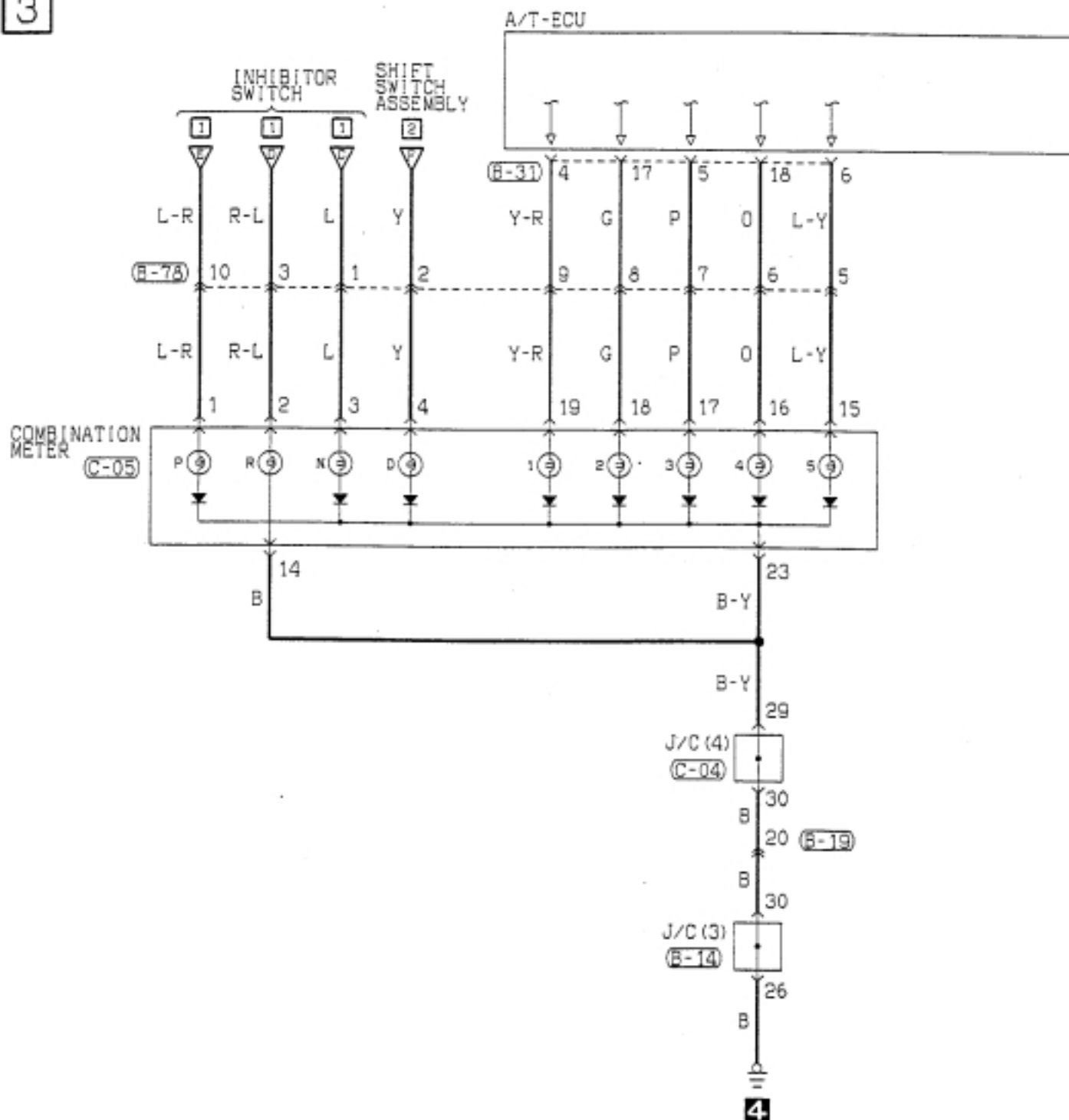

4



4

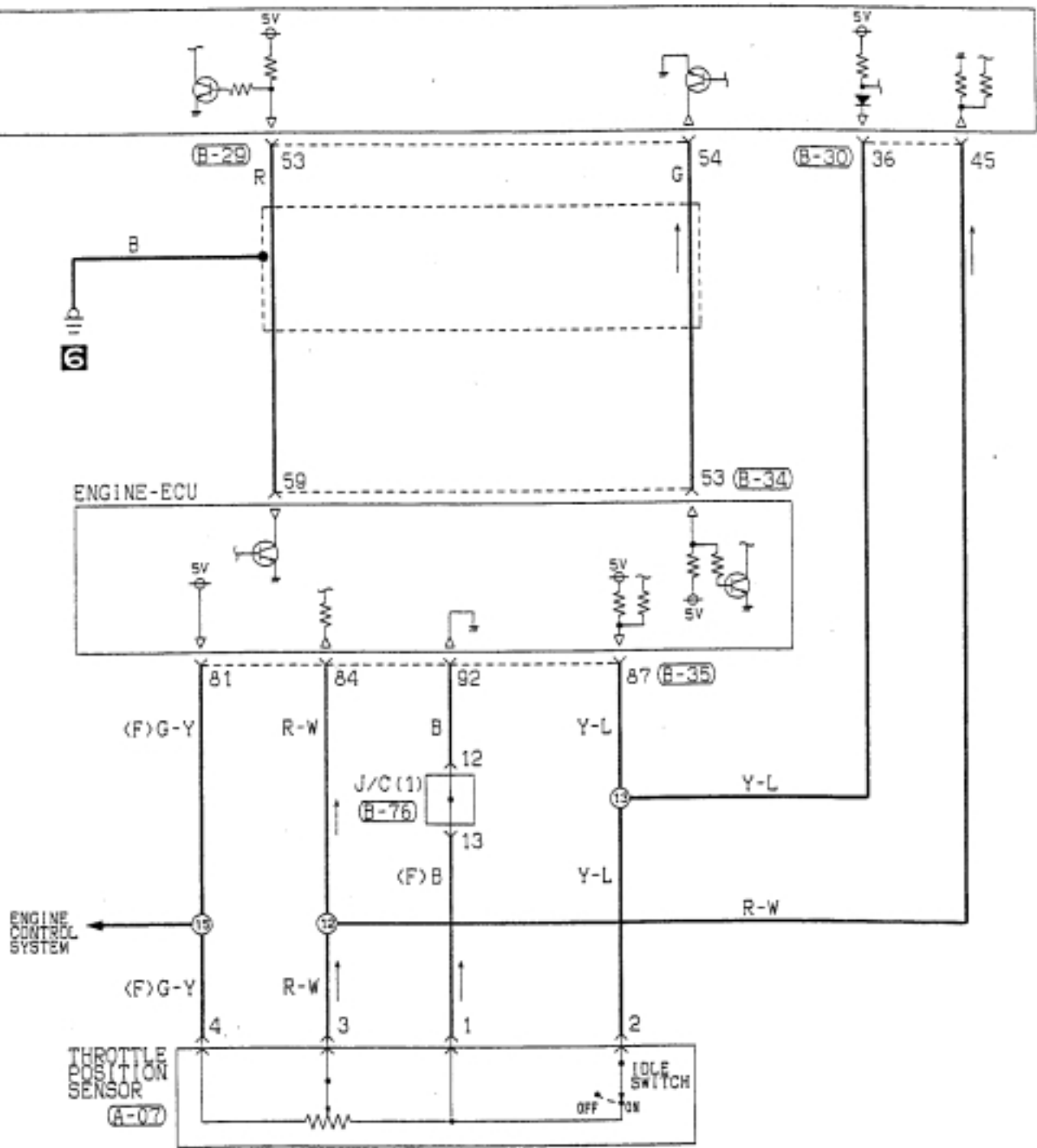

(B-34)

3	1	2	3	4	5	6	7	8	9	10	11
12	13	14	15	16	17	18	19	20	21	22	23

(B-35)

1	2	3	4	5	6	7	8	9	10	11	12	13	14	15	16	17	18	19	20	21	22	23	24	25	26	27	28	29	30	31	32	33	34	35	36	37	38	39	40	41	42	43	44	45	46	47	48	49	50	51	52	53	54	55	56	57	58	59	60	61	62	63	64	65	66	67	68	69	70	71	72	73	74	75	76	77	78	79	80	81	82	83	84	85	86	87	88	89	90	91	92	93	94	95	96	97	98	99	100
---	---	---	---	---	---	---	---	---	----	----	----	----	----	----	----	----	----	----	----	----	----	----	----	----	----	----	----	----	----	----	----	----	----	----	----	----	----	----	----	----	----	----	----	----	----	----	----	----	----	----	----	----	----	----	----	----	----	----	----	----	----	----	----	----	----	----	----	----	----	----	----	----	----	----	----	----	----	----	----	----	----	----	----	----	----	----	----	----	----	----	----	----	----	----	----	----	----	----	-----

(B-76)

1	2	3	4	5	6	7	8	9	10	11	12	13	14	15	16	17	18	19	20	21	22	23	24	25	26	27	28	29	30	31	32	33	34	35	36	37	38	39	40	41	42	43	44	45	46	47	48	49	50	51	52	53	54	55	56	57	58	59	60	61	62	63	64	65	66	67	68	69	70	71	72	73	74	75	76	77	78	79	80	81	82	83	84	85	86	87	88	89	90	91	92	93	94	95	96	97	98	99	100
---	---	---	---	---	---	---	---	---	----	----	----	----	----	----	----	----	----	----	----	----	----	----	----	----	----	----	----	----	----	----	----	----	----	----	----	----	----	----	----	----	----	----	----	----	----	----	----	----	----	----	----	----	----	----	----	----	----	----	----	----	----	----	----	----	----	----	----	----	----	----	----	----	----	----	----	----	----	----	----	----	----	----	----	----	----	----	----	----	----	----	----	----	----	----	----	----	----	----	-----

(B-78)

1	2	3	4	5	6	7	8	9	10	11	12	13	14	15	16	17	18	19	20	21	22	23	24	25	26	27	28	29	30	31	32	33	34	35	36	37	38	39	40	41	42	43	44	45	46	47	48	49	50	51	52	53	54	55	56	57	58	59	60	61	62	63	64	65	66	67	68	69	70	71	72	73	74	75	76	77	78	79	80	81	82	83	84	85	86	87	88	89	90	91	92	93	94	95	96	97	98	99	100
---	---	---	---	---	---	---	---	---	----	----	----	----	----	----	----	----	----	----	----	----	----	----	----	----	----	----	----	----	----	----	----	----	----	----	----	----	----	----	----	----	----	----	----	----	----	----	----	----	----	----	----	----	----	----	----	----	----	----	----	----	----	----	----	----	----	----	----	----	----	----	----	----	----	----	----	----	----	----	----	----	----	----	----	----	----	----	----	----	----	----	----	----	----	----	----	----	----	----	-----

(C-04)

1	2	3	4	5	6	7	8	9	10	11	12	13	14	15	16	17	18	19	20	21	22	23	24	25	26	27	28	29	30	31	32	33	34	35	36	37	38	39	40	41	42	43	44	45	46	47	48	49	50	51	52	53	54	55	56	57	58	59	60	61	62	63	64	65	66	67	68	69	70	71	72	73	74	75	76	77	78	79	80	81	82	83	84	85	86	87	88	89	90	91	92	93	94	95	96	97	98	99	100
---	---	---	---	---	---	---	---	---	----	----	----	----	----	----	----	----	----	----	----	----	----	----	----	----	----	----	----	----	----	----	----	----	----	----	----	----	----	----	----	----	----	----	----	----	----	----	----	----	----	----	----	----	----	----	----	----	----	----	----	----	----	----	----	----	----	----	----	----	----	----	----	----	----	----	----	----	----	----	----	----	----	----	----	----	----	----	----	----	----	----	----	----	----	----	----	----	----	----	-----

(C-05)

1	2	3	4	5	6	7	8	9	10	11	12	13	14	15	16	17	18	19	20	21	22	23	24	25	26	27	28	29	30	31	32	33	34	35	36	37	38	39	40	41	42	43	44	45	46	47	48	49	50	51	52	53	54	55	56	57	58	59	60	61	62	63	64	65	66	67	68	69	70	71	72	73	74	75	76	77	78	79	80	81	82	83	84	85	86	87	88	89	90	91	92	93	94	95	96	97	98	99	100
---	---	---	---	---	---	---	---	---	----	----	----	----	----	----	----	----	----	----	----	----	----	----	----	----	----	----	----	----	----	----	----	----	----	----	----	----	----	----	----	----	----	----	----	----	----	----	----	----	----	----	----	----	----	----	----	----	----	----	----	----	----	----	----	----	----	----	----	----	----	----	----	----	----	----	----	----	----	----	----	----	----	----	----	----	----	----	----	----	----	----	----	----	----	----	----	----	----	----	-----

Wire colour CODE  
 B : Black LG : Light Green G : Green L : Blue W : White Y : Yellow SB : Sky blue  
 BR : Brown O : Orange GR : Gray R : Red P : Pink V : Violet

INVECS-II 5A/T  
Vehicles without TCL (CONTINUED)

5

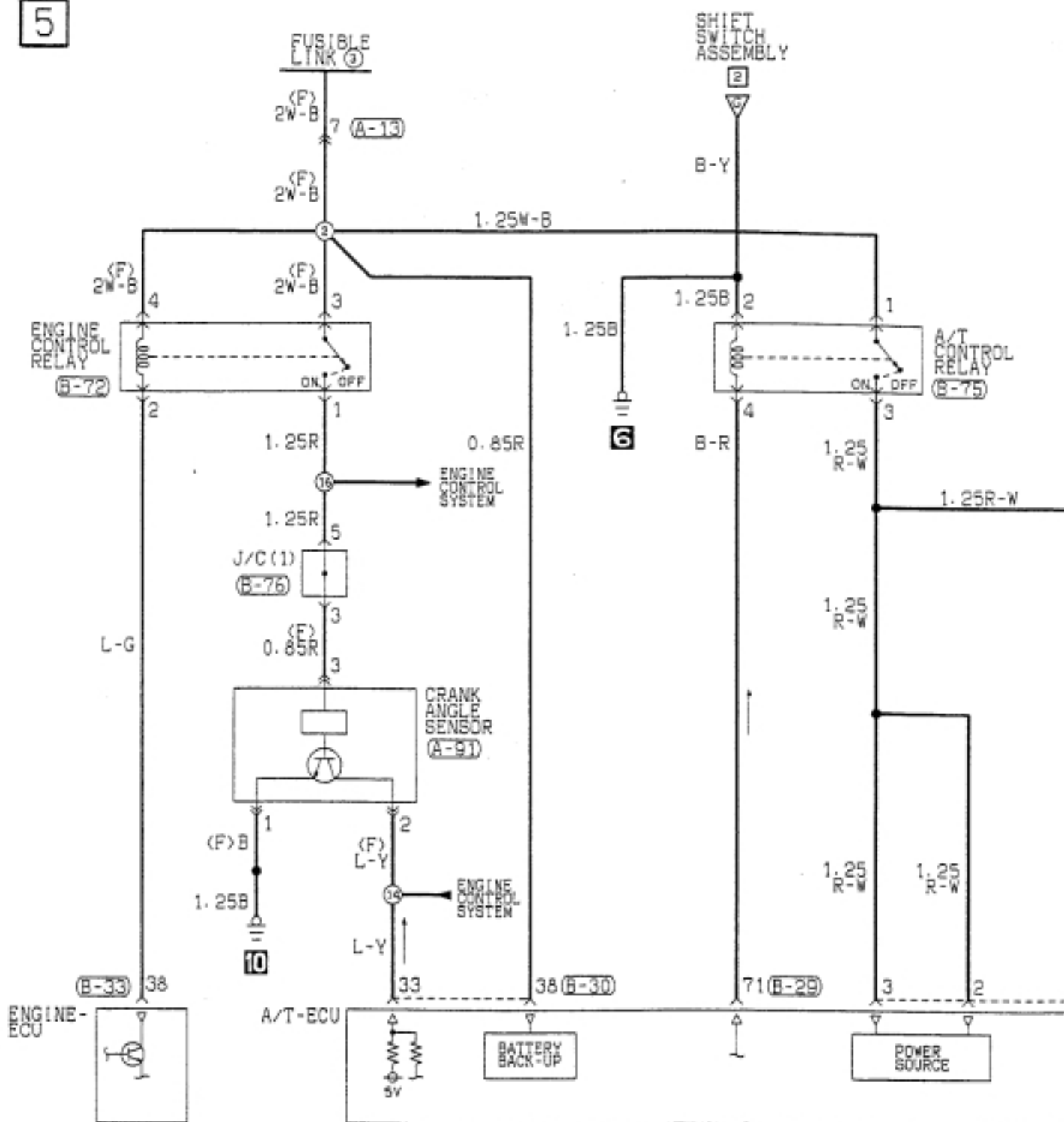

- A-13
- A-25
- A-91
- B-29
- B-30
- B-31
- B-33

6

- REMARK
- #1: UNDERDRIVE SOLENOID VALVE
  - #2: SECOND SOLENOID VALVE
  - #3: OVERDRIVE SOLENOID VALVE
  - #4: DAMPER CLUTCH CONTROL SOLENOID VALVE
  - #5: REDUCTION SOLENOID VALVE
  - #6: LOW AND REVERSE SOLENOID VALVE

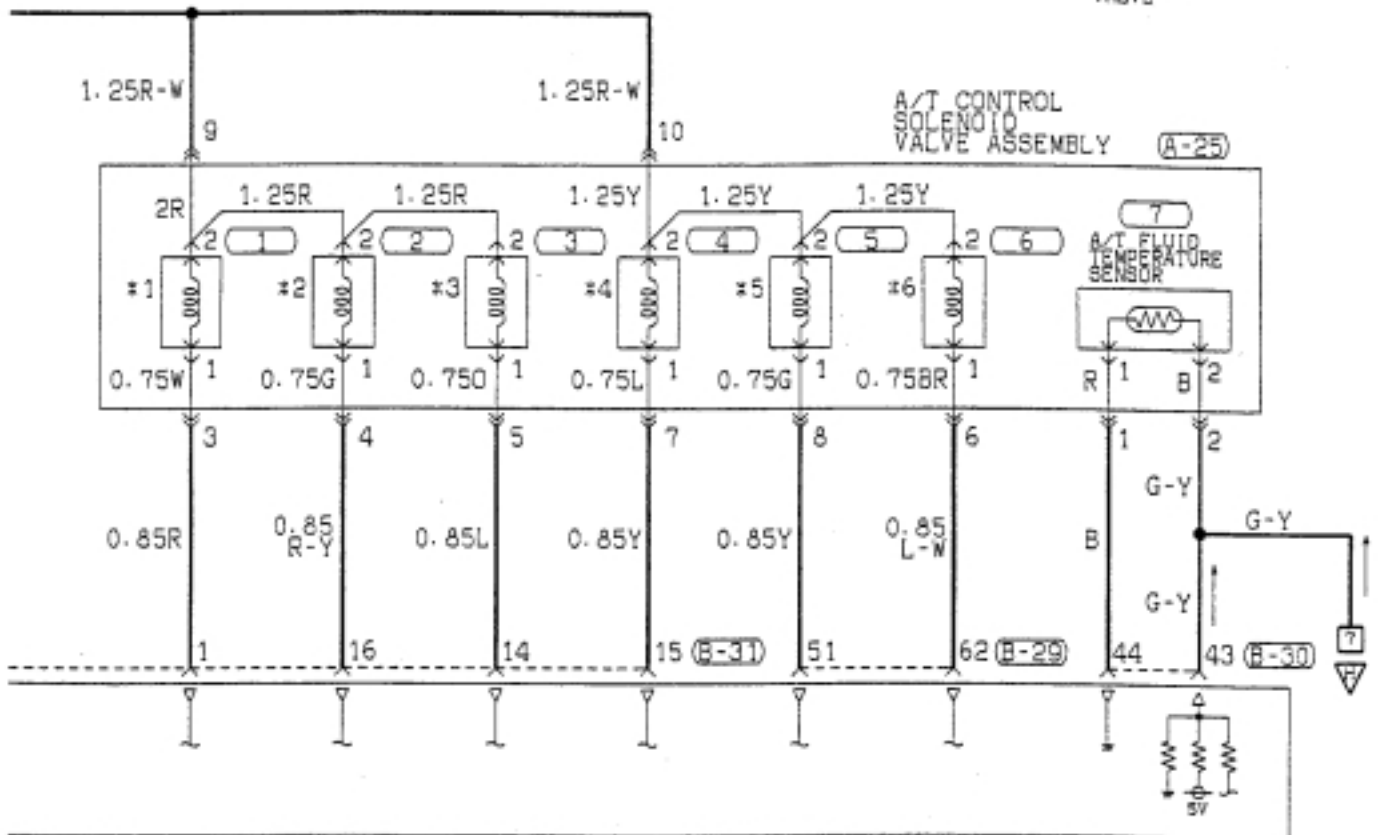

Mira colour code  
 B : Black LG : Light green G : Green L : Blue W : White Y : Yellow SB : Sky blue  
 BR : Brown O : Orange GR : Gray R : Red P : Pink V : Violet

INVECS-II 5A/T  
Vehicles without TCL (CONTINUED)

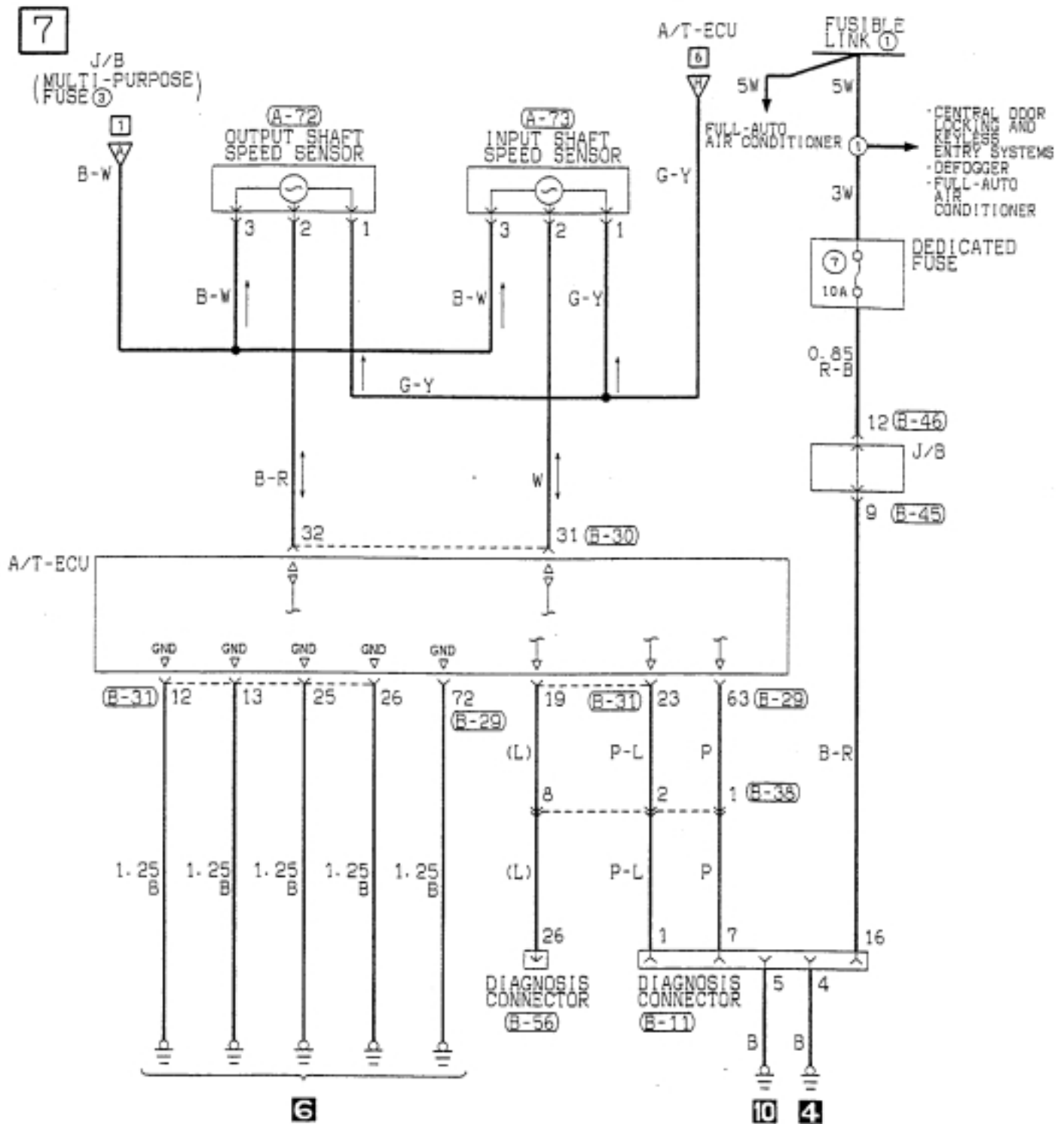

<b>A-72</b> 	<b>A-73</b> 	<b>B-11</b> FRONT SIDE 	<b>B-29</b> 	<b>B-30</b> 	<b>B-31</b> 	<b>B-38</b> 
<b>B-45</b> 	<b>B-46</b> 	<b>B-56</b> FRONT SIDE 	Wire colour code B : Black      LG : Light green      G : Green BR : Brown      O : Orange      GR : Gray W : White      SB : Sky blue      P : Pink V : Violet      Y : Yellow			

6107X00DA

---

NOTES



INVECS-II 5A/T

Vehicles with TCL

1

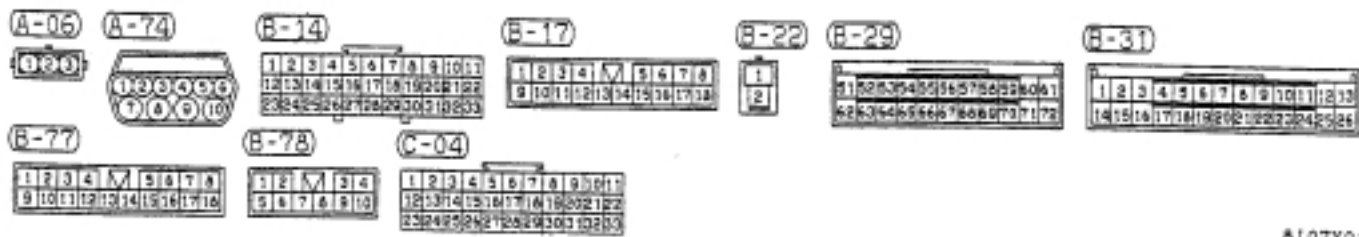
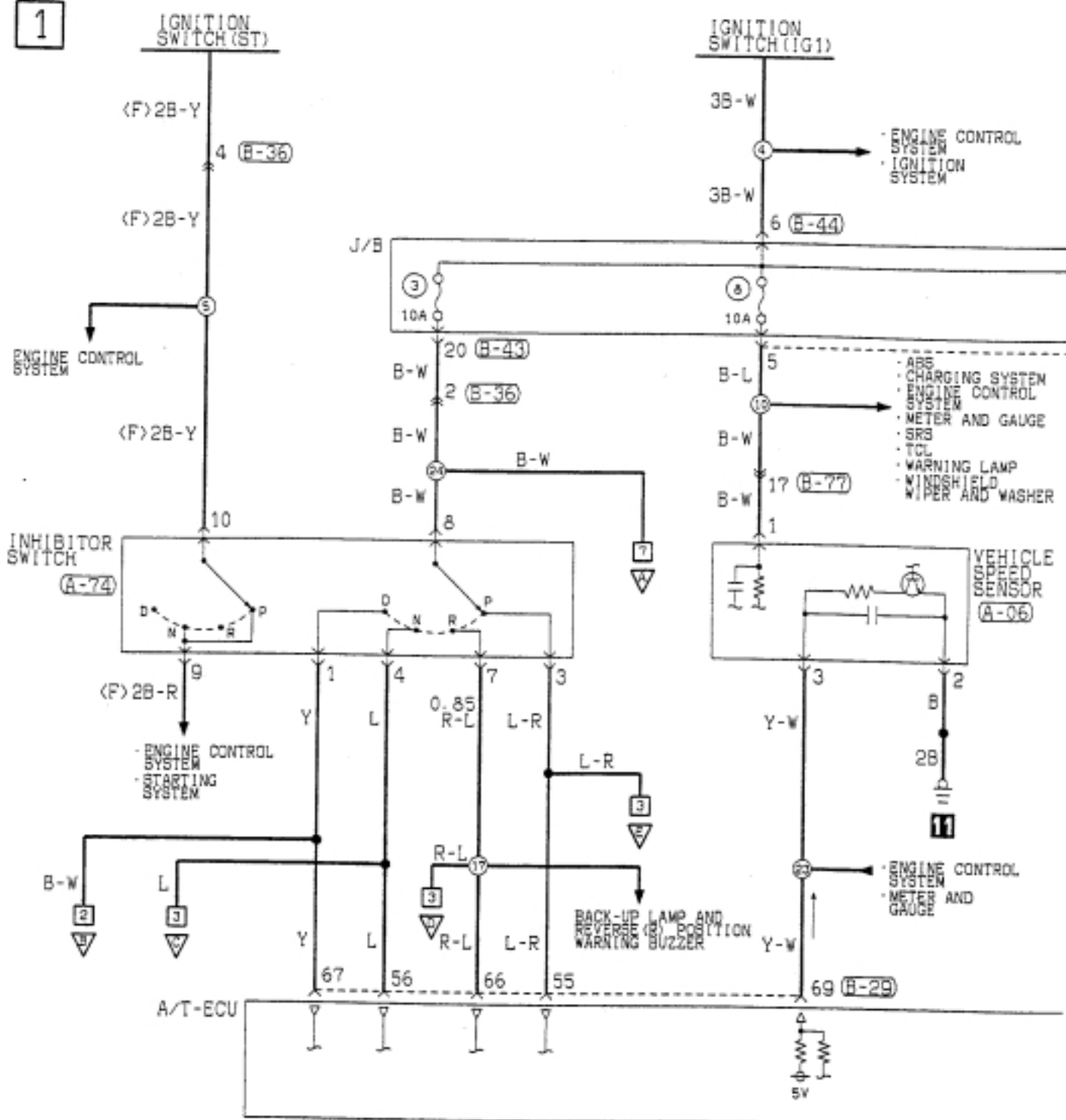

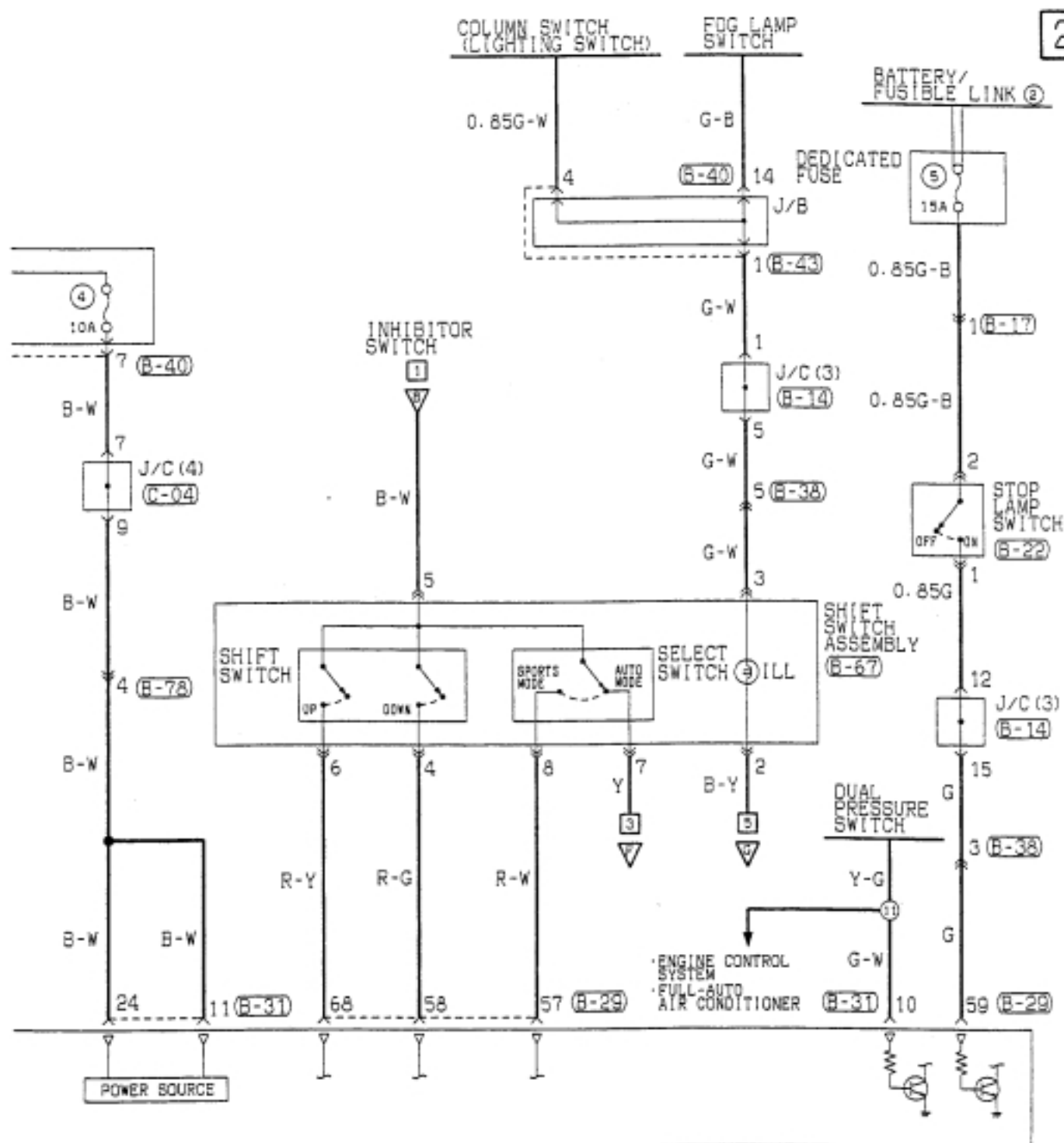

B-36

1	2	3	4	5	6	7	8	9	10	11	12	13	14	15	16
17	18	19	20	21	22	23	24	25	26	27	28	29	30	31	32

B-38

1	2	3	4	5	6	7	8
9	10	11	12	13	14	15	16

B-40

1	2	3	4	5	6	7	8	9	10	11	12	13	14	15	16	17	18	19	20	21	22
---	---	---	---	---	---	---	---	---	----	----	----	----	----	----	----	----	----	----	----	----	----

B-43

1	2	3	4	5	6	7	8	9	10	11	12	13	14	15	16	17	18	19	20
---	---	---	---	---	---	---	---	---	----	----	----	----	----	----	----	----	----	----	----

B-44

1	2	3	4
5	6	7	8

B-67

1	2	3	4
5	6	7	8

Wire colour code  
 BK:Black LG:Light green G:Green B:Blue W:White Y:Yellow SB:Sky blue  
 BR:Brown O:Orange GR:Gray R:Red P:Pink V:Violet

INVECS-II 5A/T  
Vehicles with TCL (CONTINUED)

3

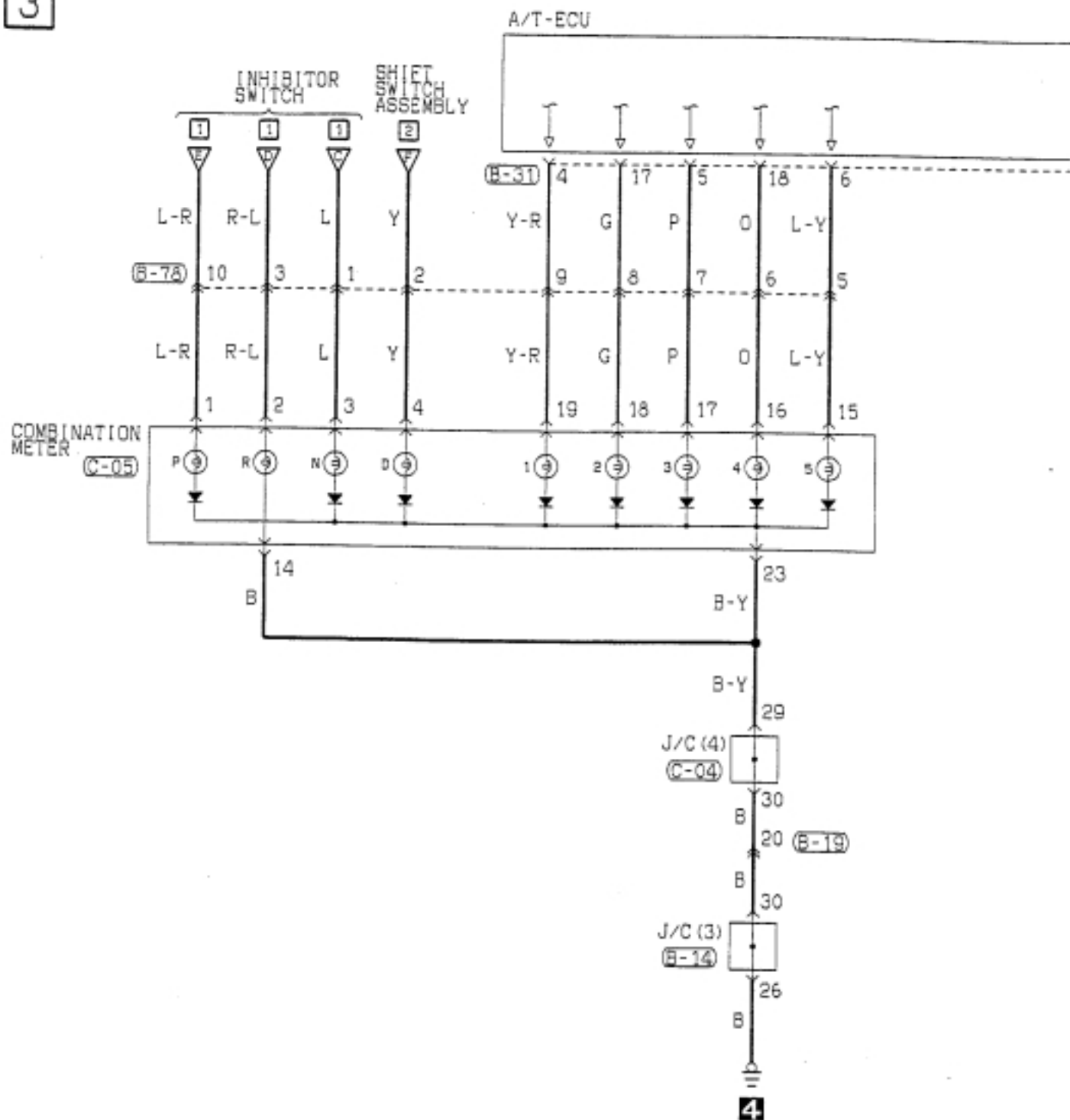

4

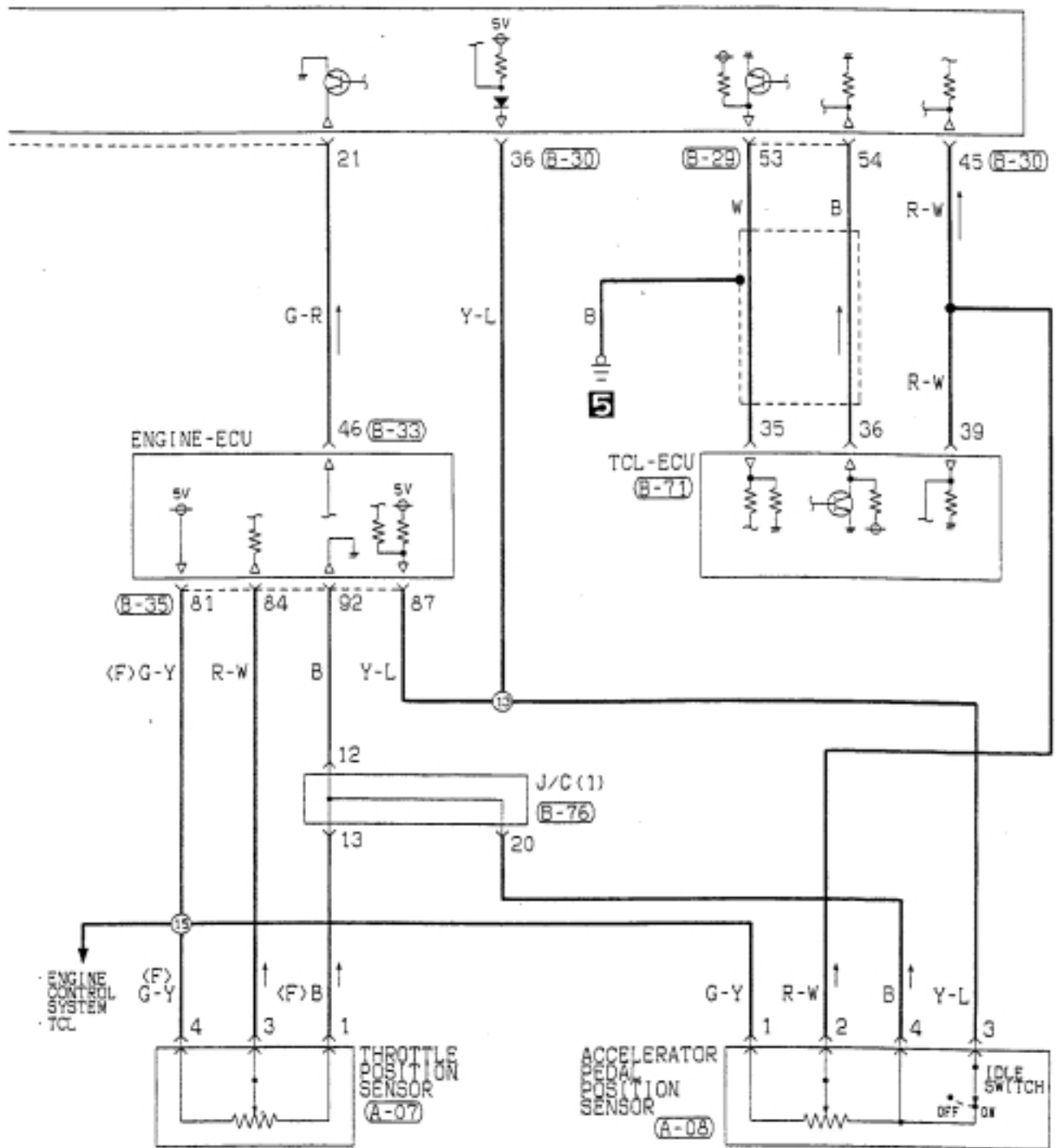

B-31

1	2	3	4	5	6	7	8	9	10	11	12	13
14	15	16	17	18	19	20	21	22	23	24	25	26

B-33

1	2	3	4	5	6	7	8	9	10	11	12	13	14	15	16	17	18	19	20	21	22	23	24	25	26	27	28	29	30	31	32	33	34	35	36	37	38	39	40	41	42	43	44	45	46	47	48	49	50
---	---	---	---	---	---	---	---	---	----	----	----	----	----	----	----	----	----	----	----	----	----	----	----	----	----	----	----	----	----	----	----	----	----	----	----	----	----	----	----	----	----	----	----	----	----	----	----	----	----

B-35

1	2	3	4	5	6	7	8	9	10	11	12	13	14	15	16	17	18	19	20	21	22	23	24	25	26	27	28	29	30	31	32	33	34	35	36	37	38	39	40	41	42	43	44	45	46	47	48	49	50
---	---	---	---	---	---	---	---	---	----	----	----	----	----	----	----	----	----	----	----	----	----	----	----	----	----	----	----	----	----	----	----	----	----	----	----	----	----	----	----	----	----	----	----	----	----	----	----	----	----

B-71

1	2	3	4	5	6	7	8	9	10	11	12	13	14	15	16	17	18	19	20	21	22	23	24	25	26	27	28	29	30	31	32	33	34	35	36	37	38	39	40	41	42	43	44	45	46	47	48	49	50
---	---	---	---	---	---	---	---	---	----	----	----	----	----	----	----	----	----	----	----	----	----	----	----	----	----	----	----	----	----	----	----	----	----	----	----	----	----	----	----	----	----	----	----	----	----	----	----	----	----

B-76

1	2	3	4	5	6	7	8	9	10	11	12	13	14	15	16	17	18	19	20	21	22	23	24	25	26	27	28	29	30	31	32	33	34	35	36	37	38	39	40	41	42	43	44	45	46	47	48	49	50
---	---	---	---	---	---	---	---	---	----	----	----	----	----	----	----	----	----	----	----	----	----	----	----	----	----	----	----	----	----	----	----	----	----	----	----	----	----	----	----	----	----	----	----	----	----	----	----	----	----

Wire colour code  
 BK:Black LG:Light green G:Green L:Blue W:White Y:Yellow SB:Sky blue  
 BR:Brown O:Orange GR:Gray R:Red P:Pink V:Violet

INVECS-II 5A/T  
Vehicles with TCL (CONTINUED)

5

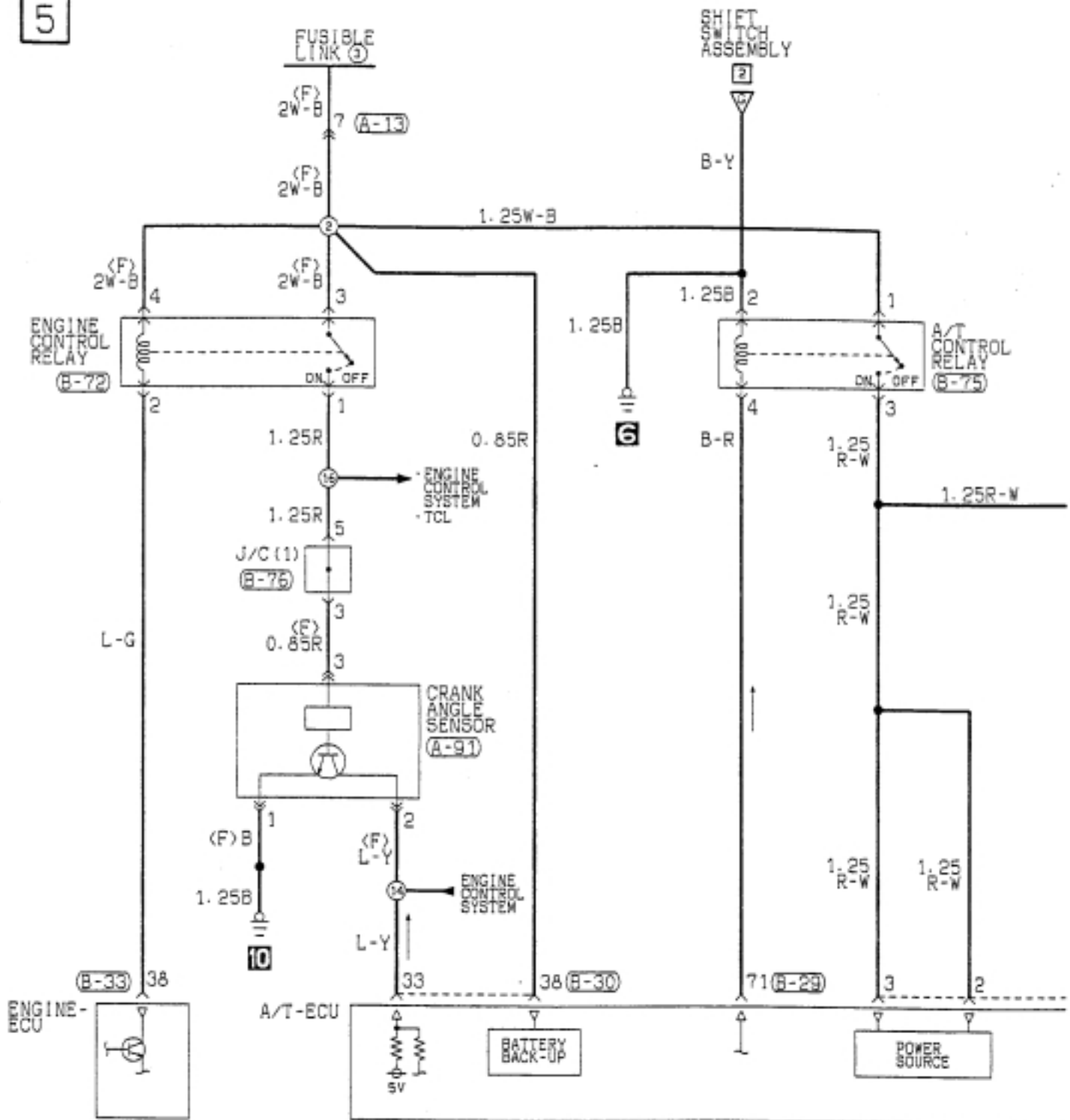

- (A-13)**
- (A-25)**
- (A-91)**
- (B-29)**
- (B-30)**
- (B-31)**
- (B-33)**

6

- REMARK
- #1: UNDERDRIVE SOLENOID VALVE
  - #2: SECOND SOLENOID VALVE
  - #3: OVERRIDE SOLENOID VALVE
  - #4: DAMPER CLUTCH CONTROL SOLENOID VALVE
  - #5: REDUCTION SOLENOID VALVE
  - #6: LOW AND REVERSE SOLENOID VALVE

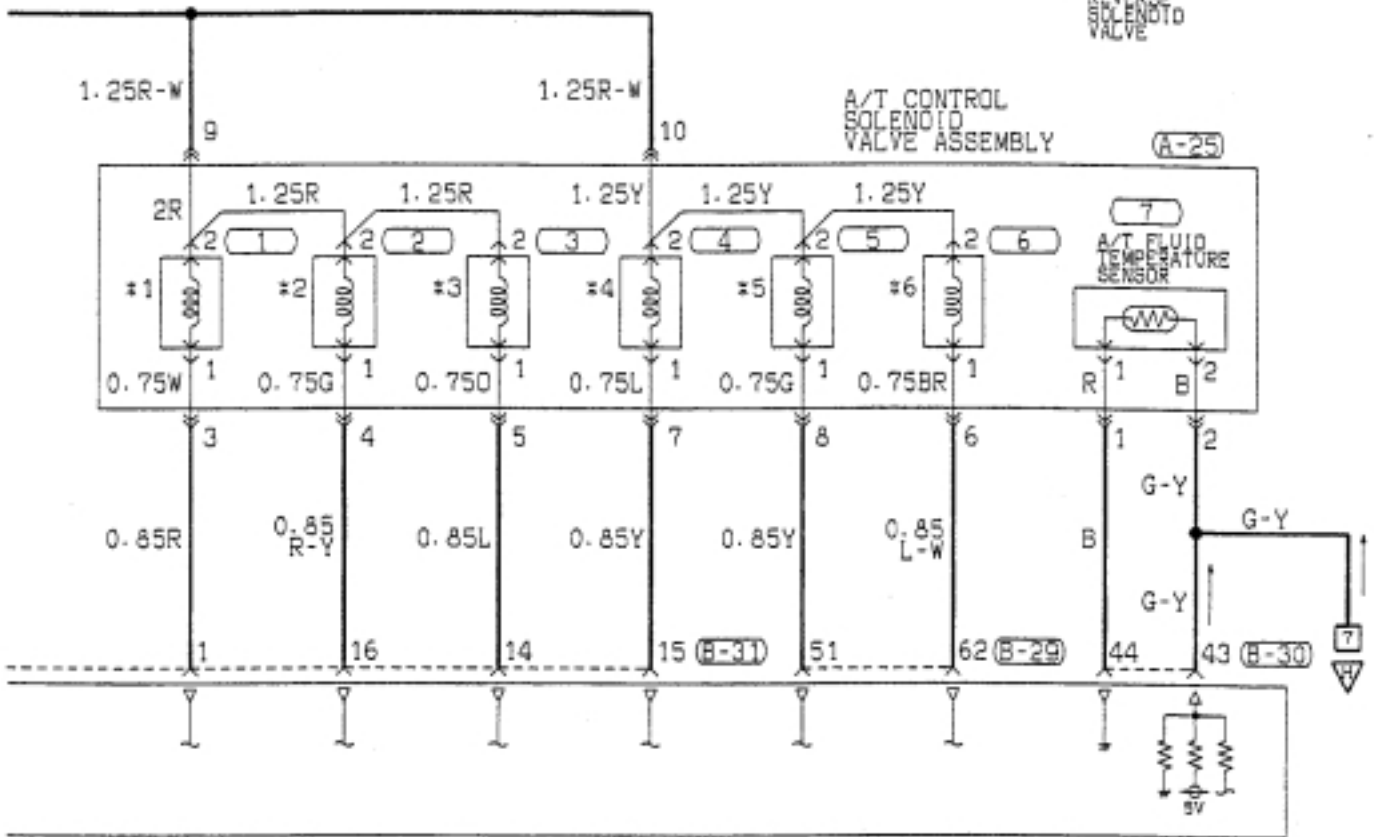

Wire colour code  
 BK:Black LG:Light green G:Green L:Blue W:White Y:Yellow SB:Sky blue  
 BR:Brown O:Orange GR:Gray R:Red P:Pink V:Violet

INVECS-II 5A/T  
Vehicles with TCL (CONTINUED)

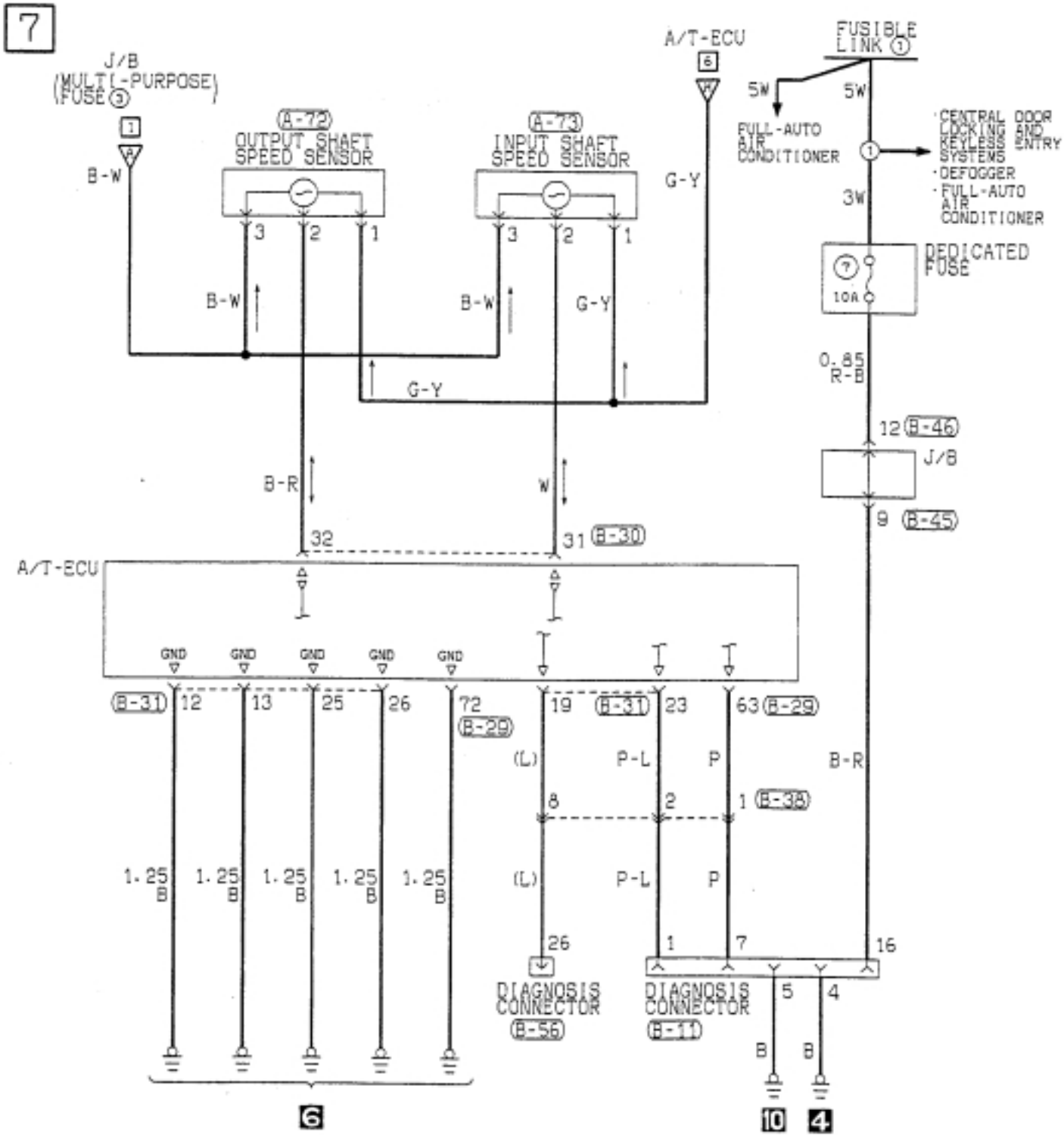

<b>A-72</b> 	<b>A-73</b> 	<b>B-11</b> FRONT SIDE 	<b>B-29</b> 	<b>B-30</b> 	<b>B-31</b> 	<b>B-38</b> 
<b>B-45</b> 	<b>B-46</b> 	<b>B-56</b> FRONT SIDE 	Wire colour code B : Black      LG : Light green      G : Green BR : Brown      O : Orange      GR : Gray W : White      SB : Sky blue      PGR : Pink V : Violet      Y : Yellow			

8107X010A

---

NOTES



# HEADLAMP

Except for discharge type

1

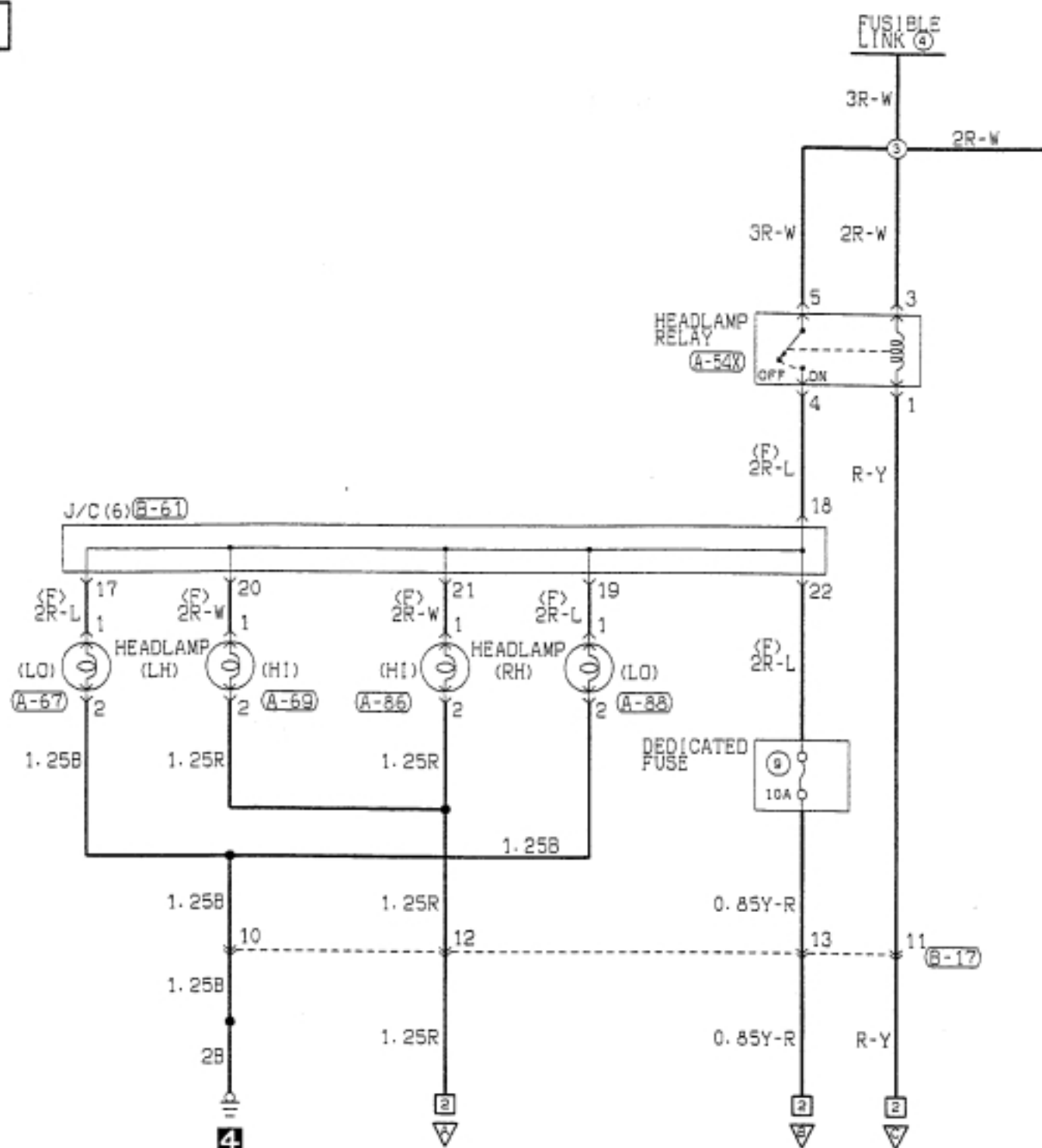

2

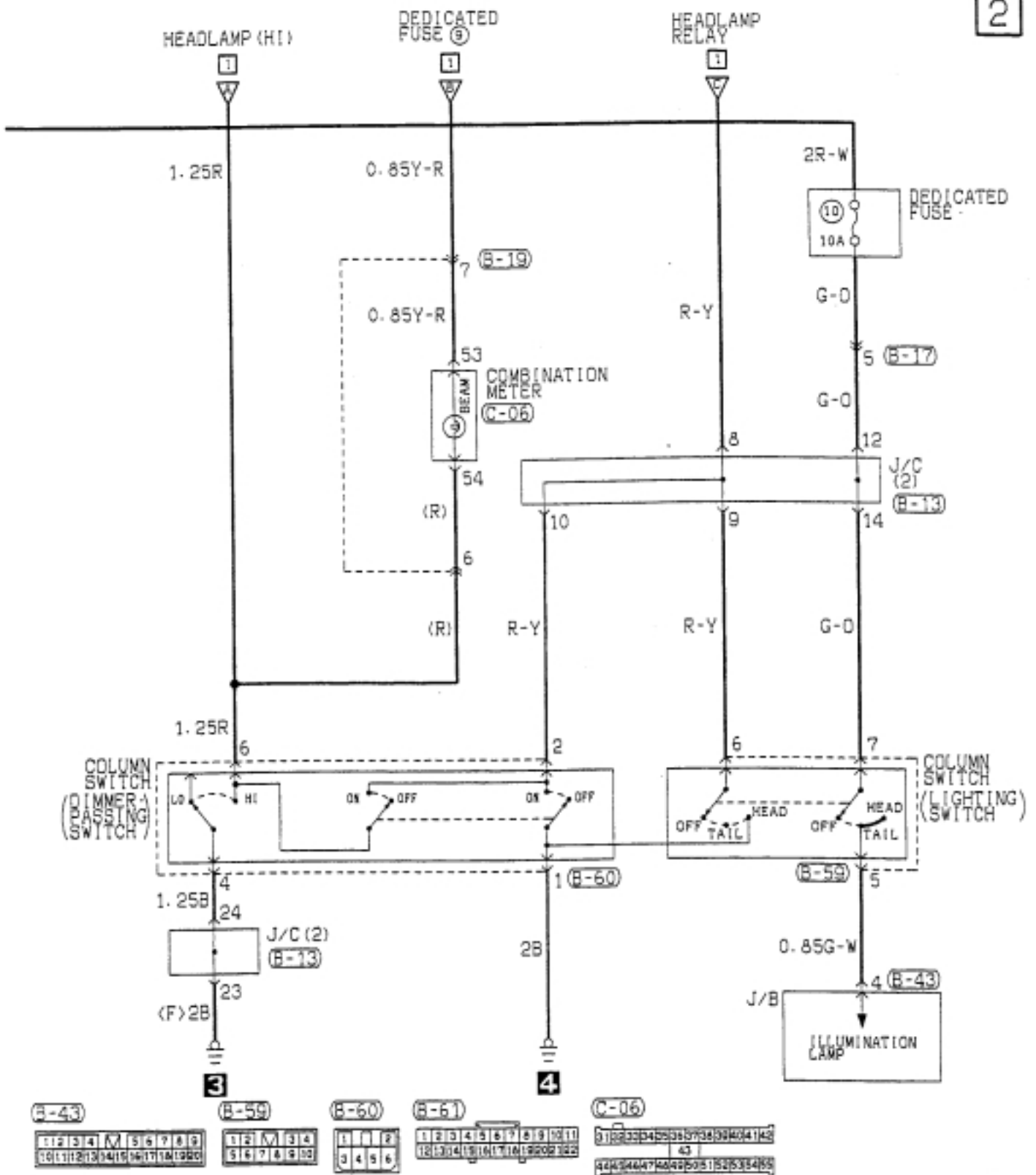

Wire colour code  
 B: Black LG: Light green G: Green L: Blue W: White Y: Yellow SB: Sky blue  
 BR: Brown O: Orange GR: Gray R: Red P: Pink V: Violet

# HEADLAMP

Discharge type

1

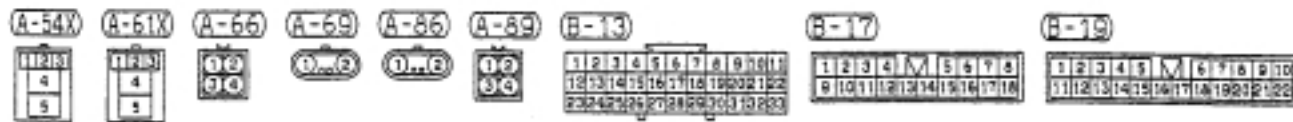
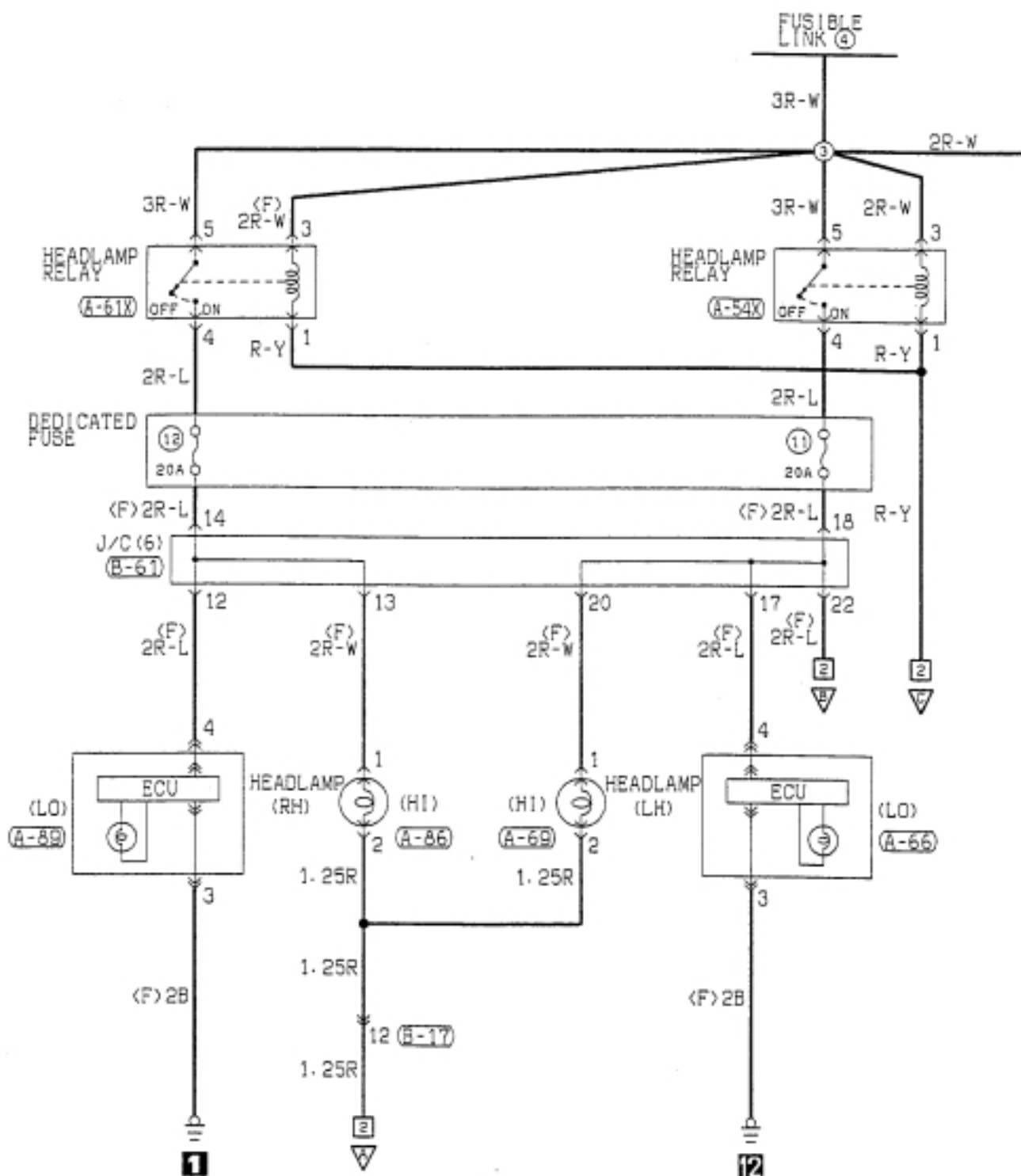

2

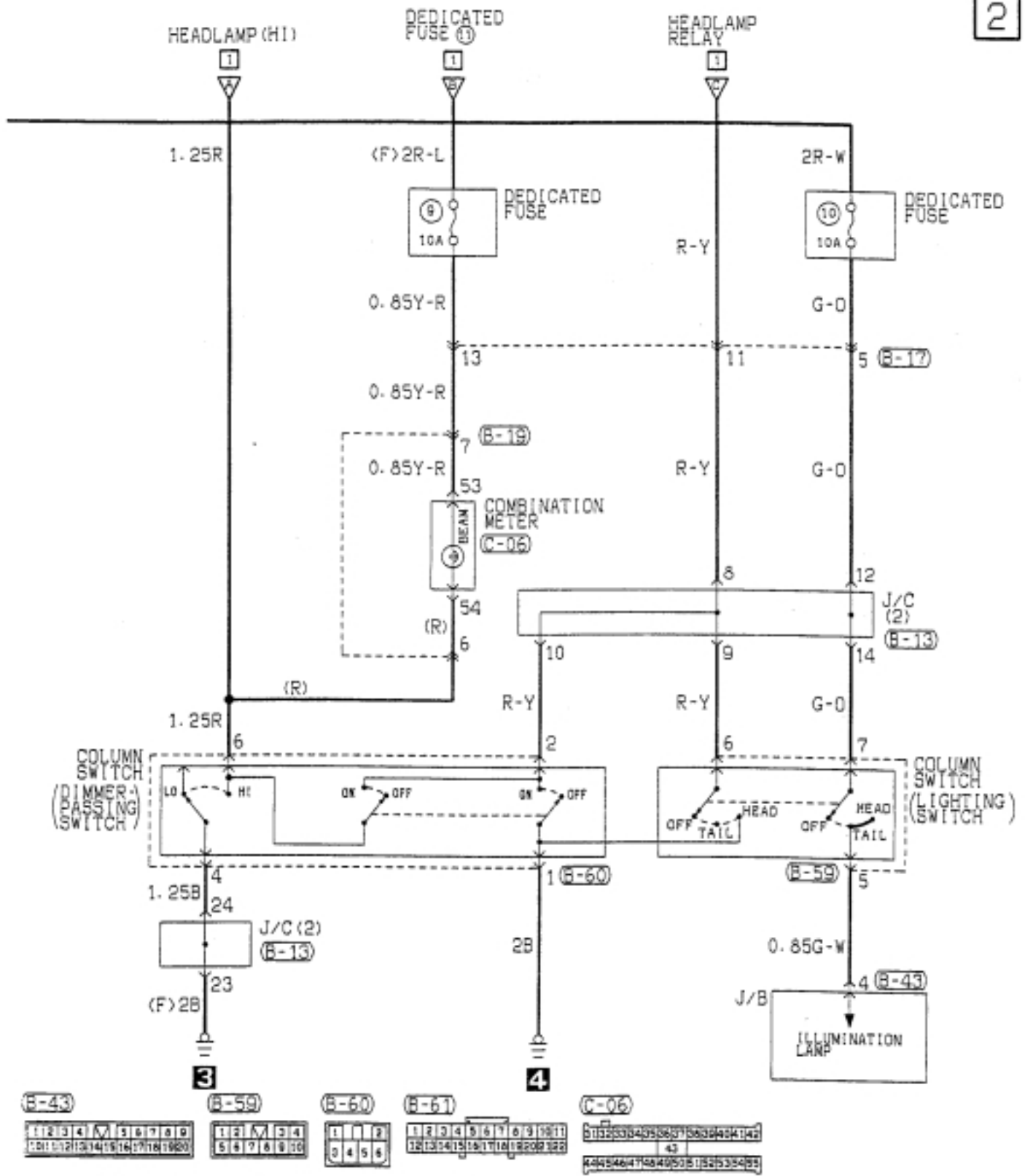

(B-43)	(B-59)	(B-60)	(B-61)	(C-06)
1 2 3 4 5 6 7 8 9 10 11 12 13 14 15 16 17 18 19 20	1 2 3 4 5 6 7 8 9 10	1 2 3 4 5 6	1 2 3 4 5 6 7 8 9 10 11 12 13 14 15 16 17 18 19 20 21 22	1 2 3 33 34 35 36 37 38 39 40 41 42
43				43
44 45 46 47 48 49 50 51 52 53 54 55				

Wire colour code  
 B:Black LG:Light green G:Green L:Blue W:White Y:Yellow SB:Sky blue  
 BR:Brown O:Orange GR:Gray R:Red P:Pink V:Violet

# TAIL LAMP, POSITION LAMP AND LICENSE PLATE LAMP

Vehicles without discharge type headlamp

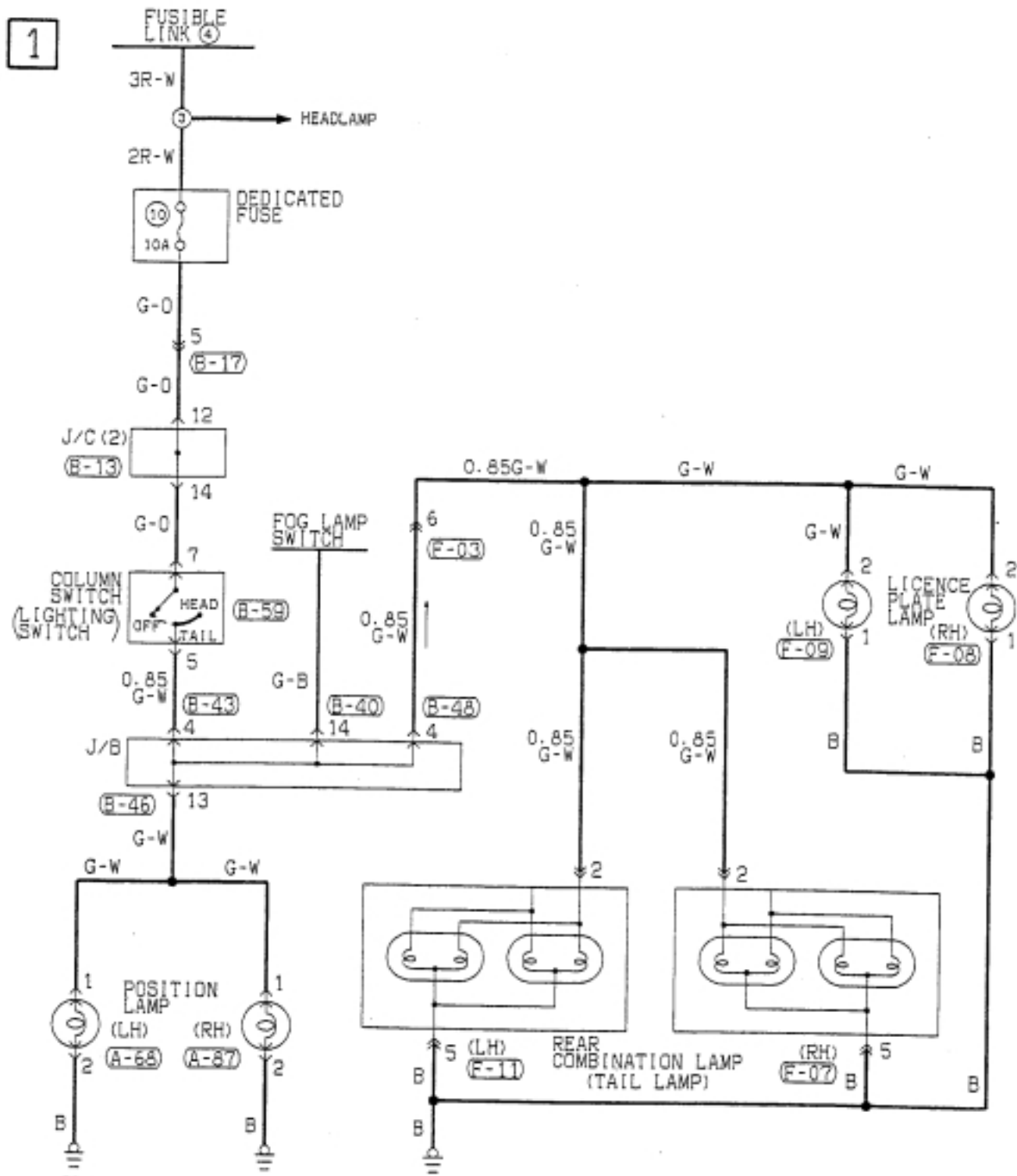

- A-68  
08
- A-87  
08
- B-13  
1 2 3 4 5 6 7 8 9 10  
11 12 13 14 15 16 17 18 19 20 21 22  
23 24 25 26 27 28 29 30 31 32 33
- B-17  
1 2 3 4 5 6 7 8 9  
10 11 12 13 14 15 16 17 18
- B-40  
1 2 3 4 5 6 7 8 9 10  
11 12 13 14 15 16 17 18 19 20 21 22
- B-43  
1 2 3 4 5 6 7 8 9  
10 11 12 13 14 15 16 17 18 19 20
- B-46  
1 2 3 4 5 6 7 8 9  
10 11 12 13 14 15 16 17 18
- B-48  
1 2 3 4 5 6 7 8 9  
10 11 12 13 14 15 16 17 18 19
- B-59  
1 2 3 4 5 6  
7 8 9 10 11
- F-03  
1 2 3 4 5 6 7 8 9 10  
11 12 13 14 15 16 17 18 19 20 21 22
- F-07  
1 2 3  
4 5 6
- F-08  
08
- F-09  
08
- F-11  
1 2 3  
4 5 6

# TAIL LAMP, POSITION LAMP AND LICENSE PLATE LAMP

Vehicles with discharge type headlamp

1

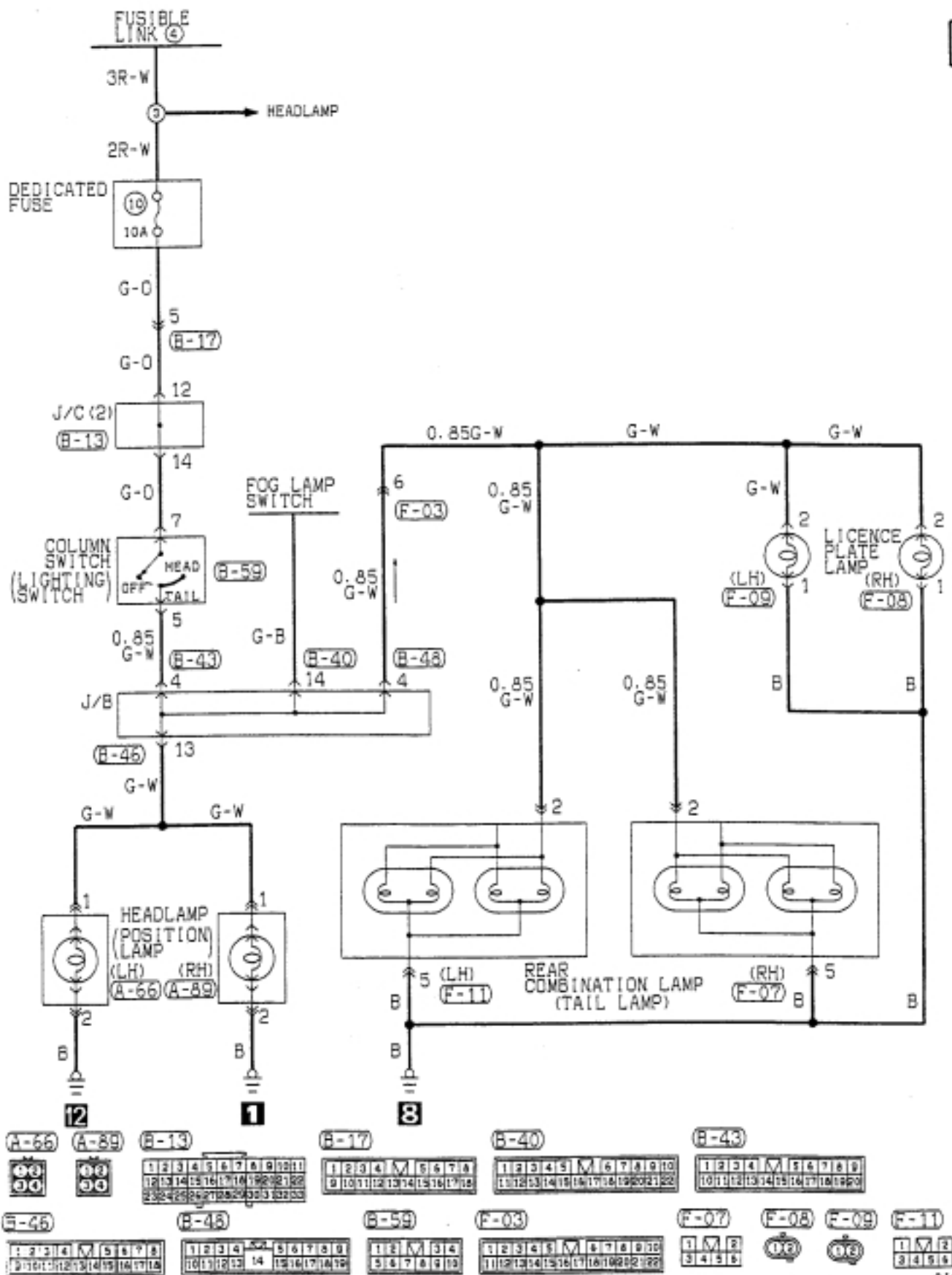

FOG LAMP

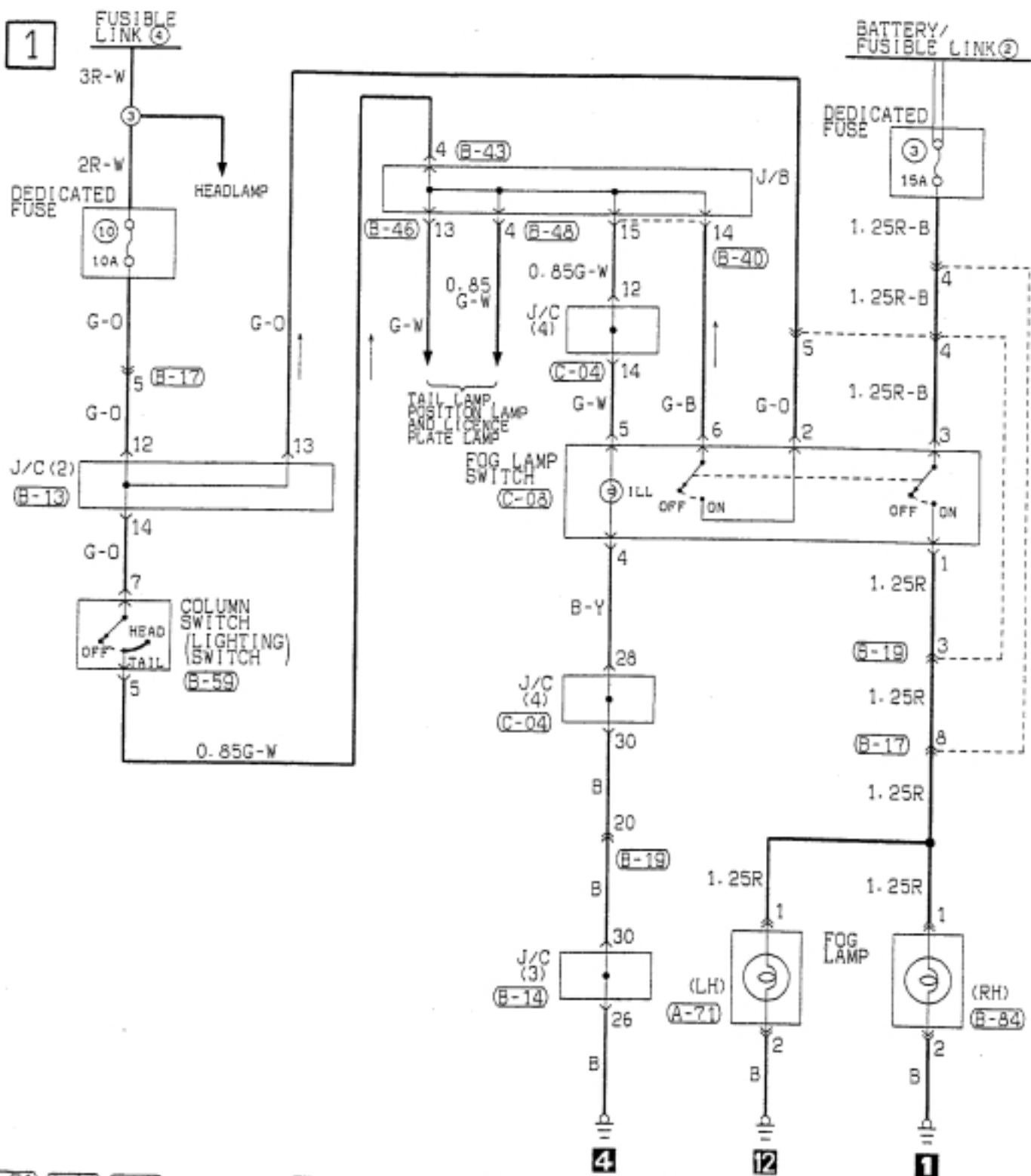

<b>A-71</b> 00	<b>A-84</b> 00	<b>B-13</b> 1 2 3 4 5 6 7 8 9 10 11 12 13 14 15 16 17 18 19 20 21 22 23 24 25 26 27 28 29 30 31 32 33	<b>B-14</b> 1 2 3 4 5 6 7 8 9 10 11 12 13 14 15 16 17 18 19 20 21 22 23 24 25 26 27 28 29 30 31 32 33	<b>B-17</b> 1 2 3 4 M 5 6 7 8 9 10 11 12 13 14 15 16 17 18	<b>B-19</b> 1 2 3 4 5 M 6 7 8 9 10 11 12 13 14 15 16 17 18 19 20 21 22	<b>B-40</b> 1 2 3 4 5 M 6 7 8 9 10 11 12 13 14 15 16 17 18 19 20 21 22
<b>B-43</b> 1 2 3 4 M 5 6 7 8 9 10 11 12 13 14 15 16 17 18 19 20	<b>B-46</b> 1 2 3 4 M 5 6 7 8 9 10 11 12 13 14 15 16 17 18	<b>B-48</b> 1 2 3 4 5 6 7 8 9 10 11 12 13 14 15 16 17 18 19	<b>B-59</b> 1 2 M 3 4 5 6 7 8 9 10	<b>C-04</b> 1 2 3 4 5 6 7 8 9 10 11 12 13 14 15 16 17 18 19 20 21 22 23 24 25 26 27 28 29 30 31 32 33	<b>C-08</b> 1 2 3 4 5 6	

# IGNITION KEY CYLINDER ILLUMINATION LAMP

1

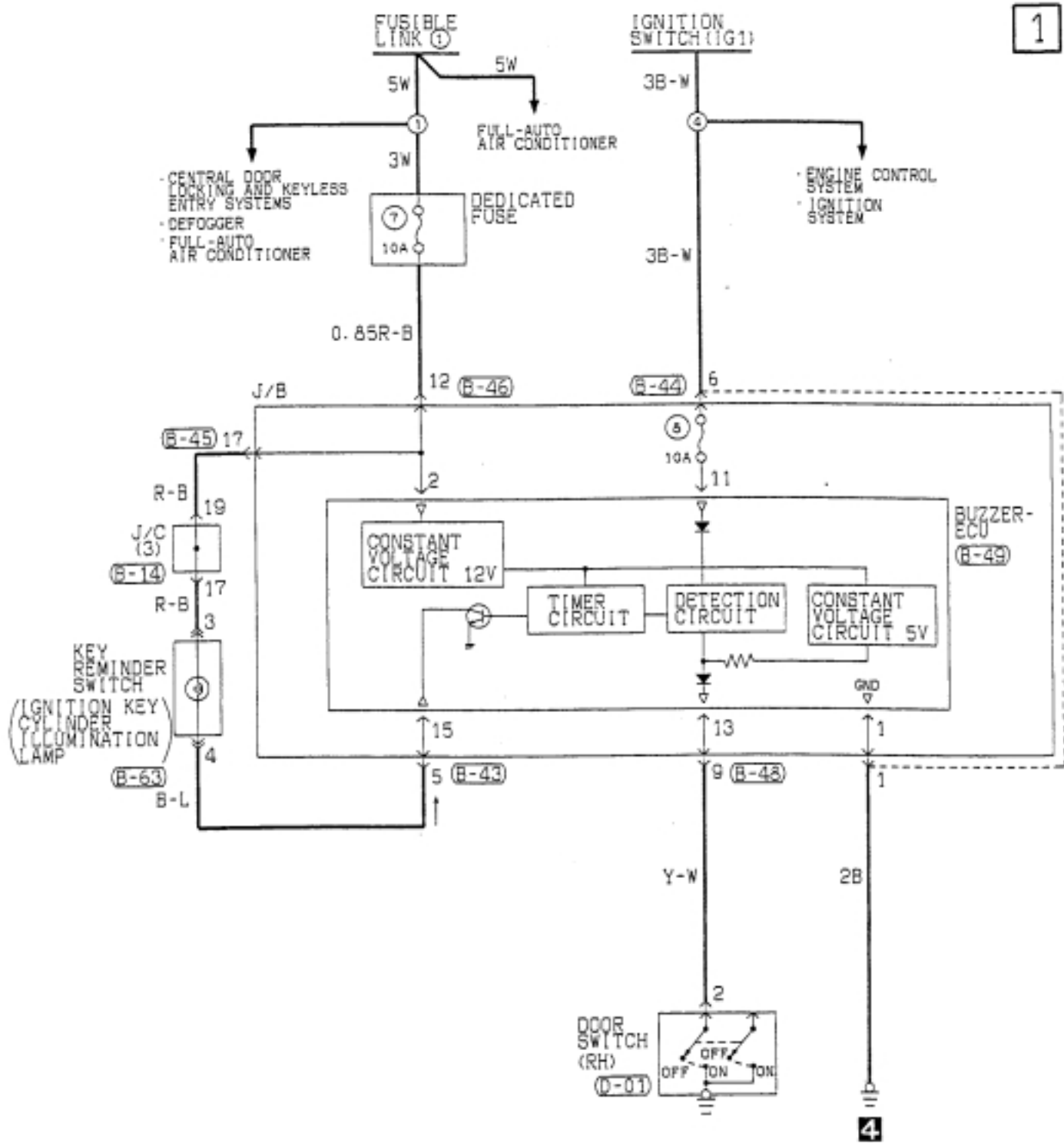

4

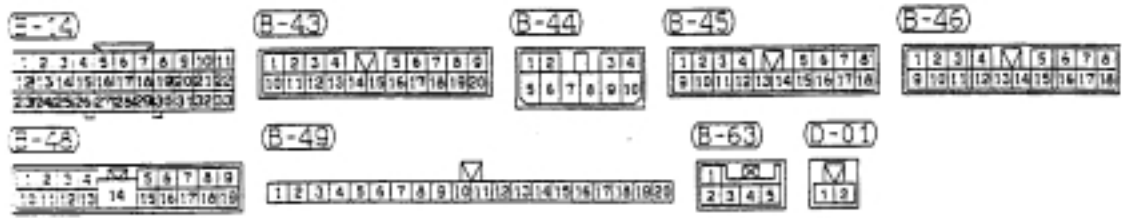



MAP LAMP AND LUGGAGE COMPARTMENT LAMP

1

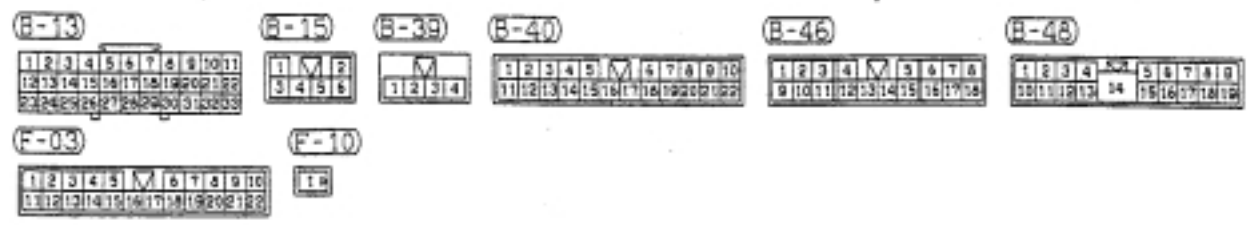
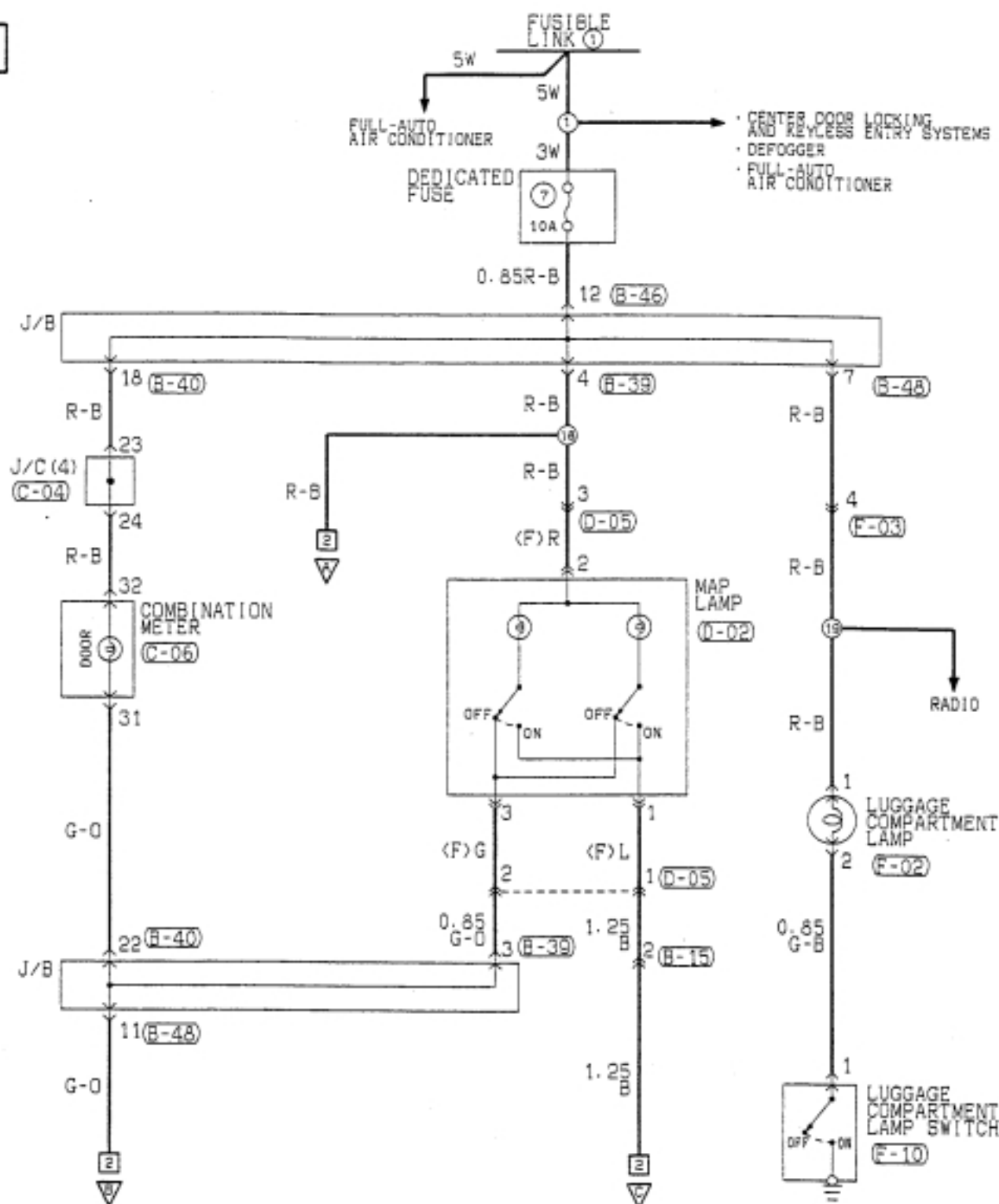

2

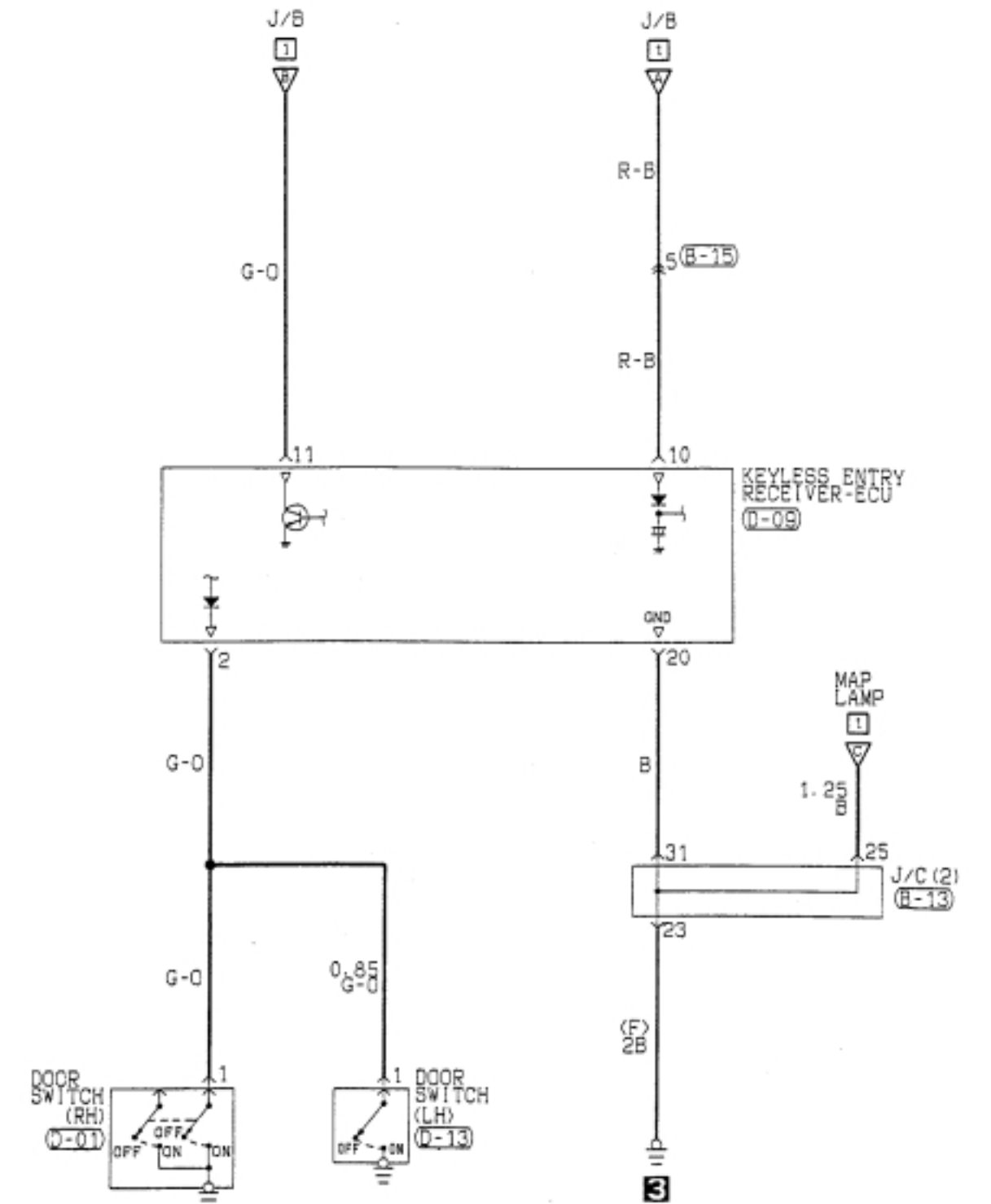

Wire colour code  
 BK: Black LG: Light green G: Green L: Blue W: White Y: Yellow SB: Sky blue  
 BR: Brown O: Orange GR: Gray R: Red P: Pink V: Violet

TURN-SIGNAL LAMP AND HAZARD WARNING LAMP

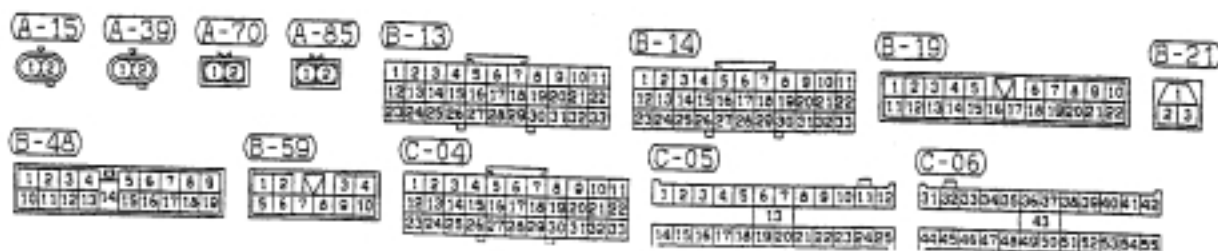
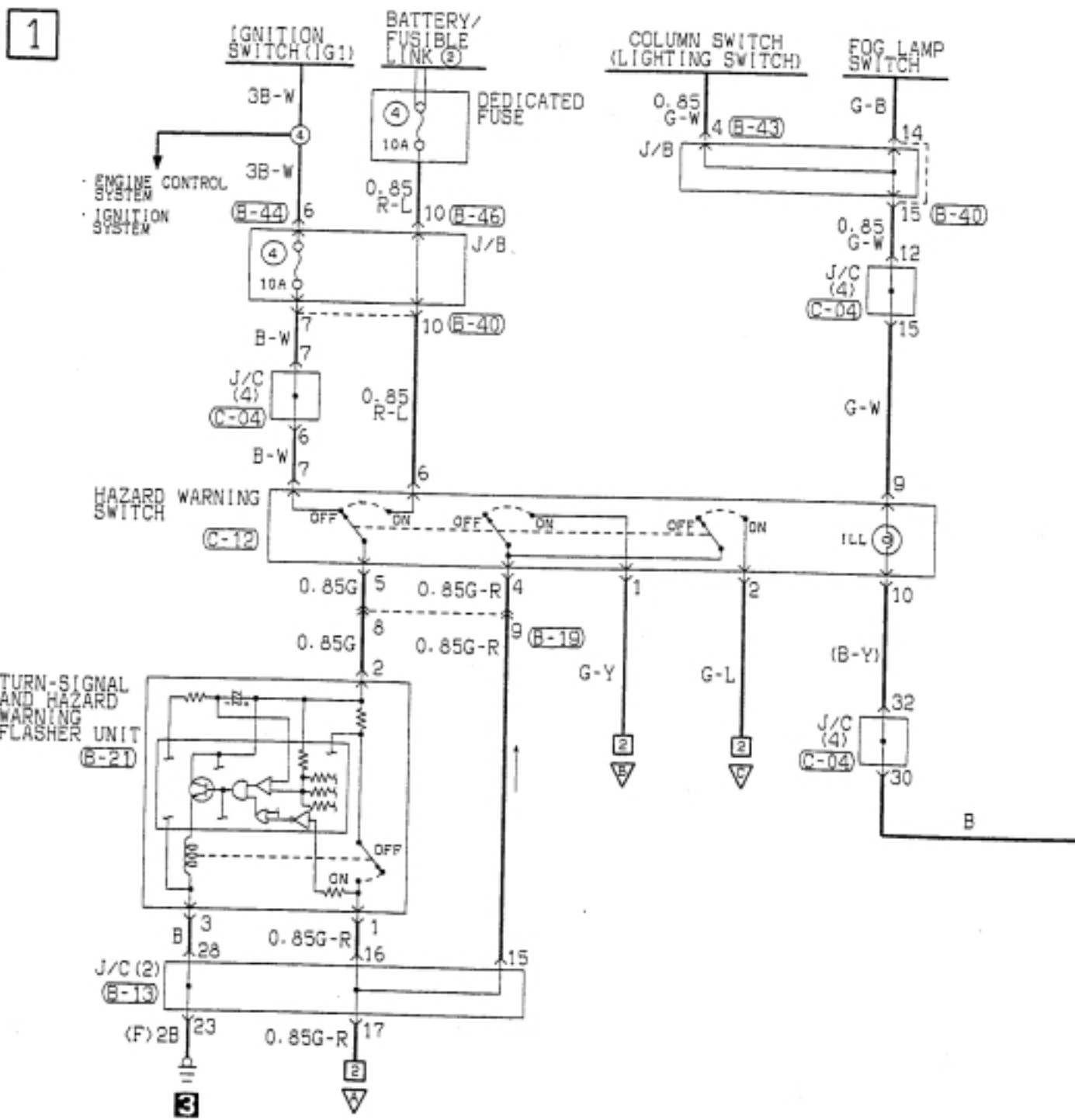

2

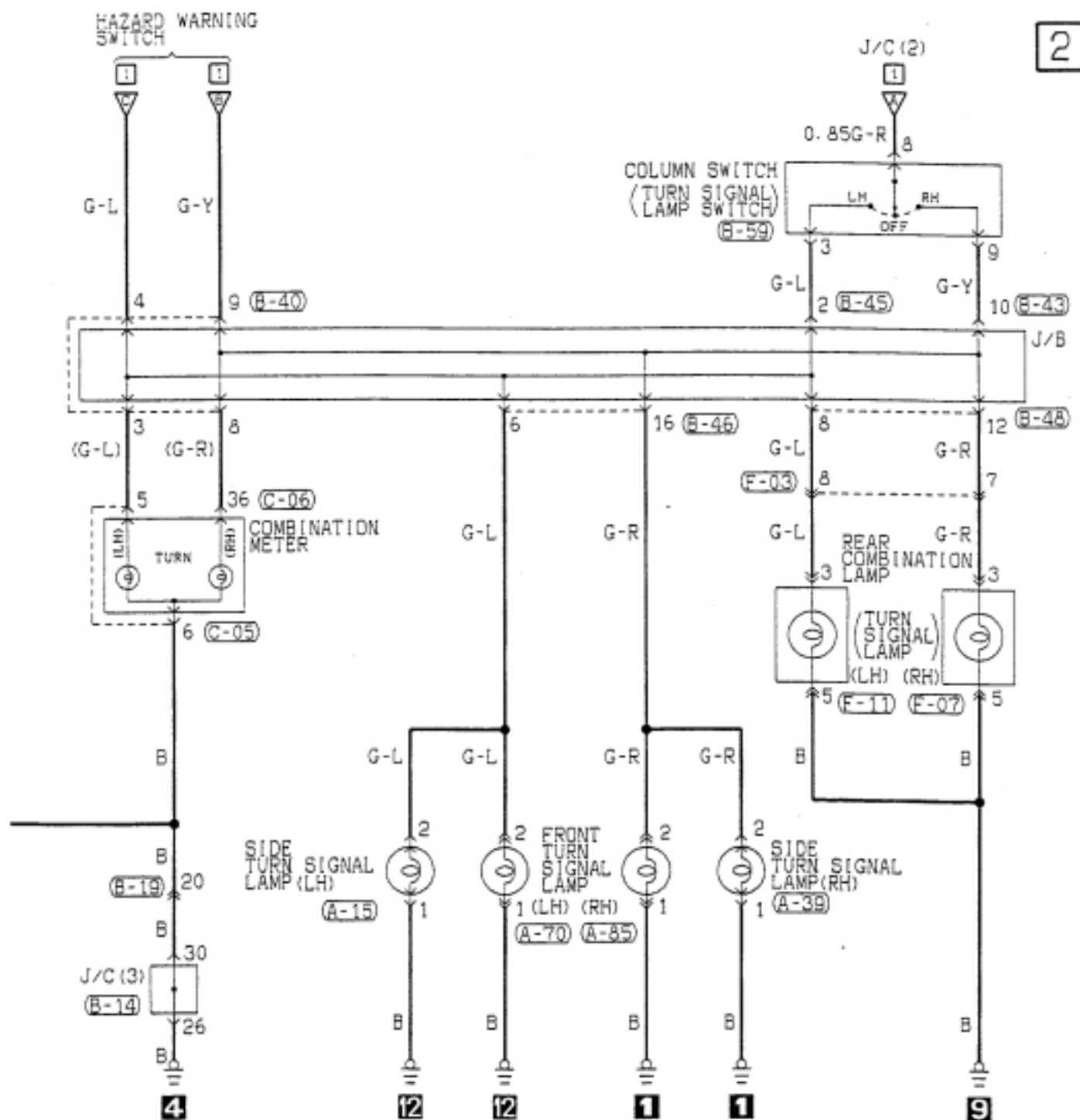

B-40

1	2	3	4	5	6	7	8	9	10
11	12	13	14	15	16	17	18	19	20

B-43

1	2	3	4	5	6	7	8	9	10
11	12	13	14	15	16	17	18	19	20

B-44

1	2	3	4
5	6	7	8

B-45

1	2	3	4	5	6	7	8
9	10	11	12	13	14	15	16

B-46

1	2	3	4	5	6	7	8
9	10	11	12	13	14	15	16

C-12

1	2	3	4
5	6	7	8

F-03

1	2	3	4	5	6	7	8	9	10
11	12	13	14	15	16	17	18	19	20

F-07

1	2	3
4	5	6

F-11

1	2	3
4	5	6

Wire colour code  
 B: Black  
 BR: Brown  
 W: White  
 V: Violet  
 CG: Light green  
 O: Orange  
 SB: Sky blue

G: Green  
 GR: Gray  
 P: Pink

L: Blue  
 R: Red  
 Y: Yellow

STOP LAMP

1

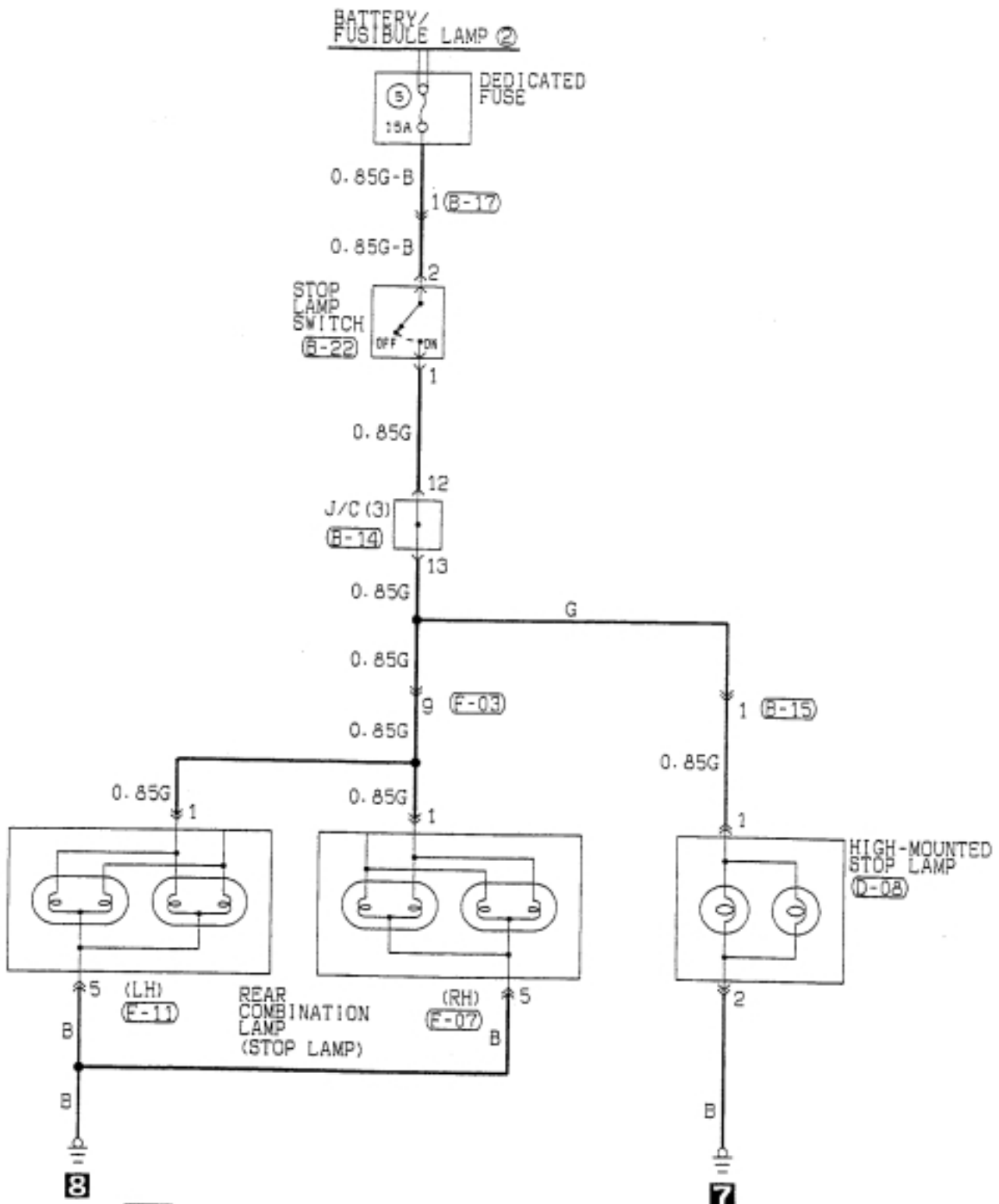

(B-14)	(B-15)	(B-17)	(B-22)	(D-08)	(F-03)	(F-07)	(F-11)
1 2 3 4 5 6 7 8 9 10 11 12 13 14 15 16 17 18 19 20 21 22 23 24 25 26 27 28 29 30 31 32 33	1 1 1 2 3 4 5 6	1 2 3 4 5 6 7 8 9 10 11 12 13 14 15 16 17 18	1 2	1 2	3 2 3 4 5 6 7 8 9 10 11 12 13 14 15 16 17 18 19 20 21 22	1 1 1 2 3 4 5 6	1 1 1 2 3 4 5 6

Wire colour code  
 BK: Black LG: Light green G: Green L: Blue W: White Y: Yellow SB: Sky blue  
 BR: Brown O: Orange GR: Gray R: Red P: Pink V: Violet

BACK-UP LAMP <M/T>

1

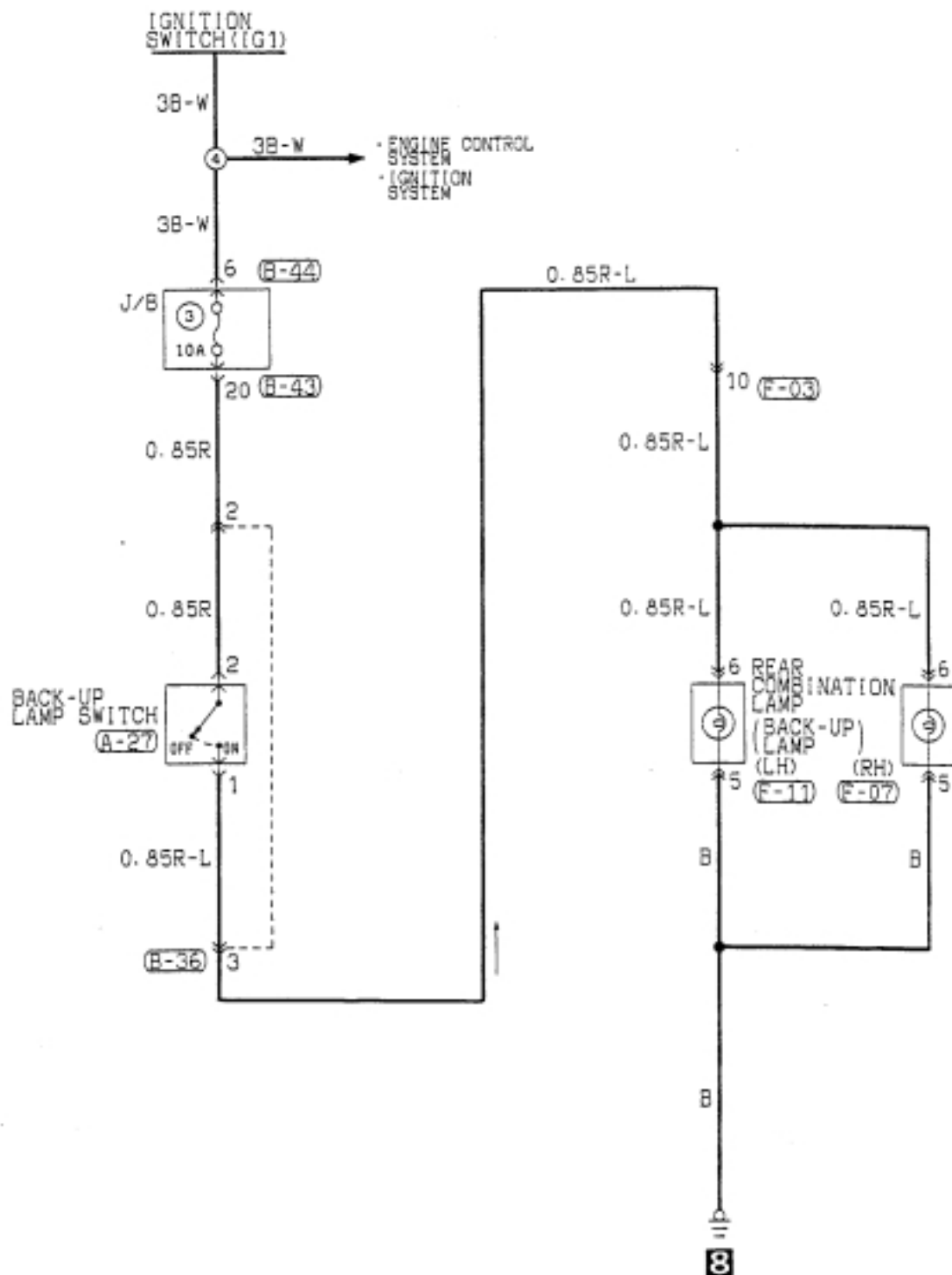

<b>A-27</b>	<b>B-36</b>	<b>B-43</b>	<b>B-44</b>	<b>F-03</b>	<b>E-07</b>	<b>E-11</b>
1 2 3 4 5 6 7 8 9 10 11 12 13 14 15 16 17 18	1 2 3 4 5 6 7 8 9 10 11 12 13 14 15 16 17 18 19 20	1 2 3 4 5 6 7 8 9 10 11 12 13 14 15 16 17 18 19 20	1 2 3 4 5 6 7 8 9 10	1 2 3 4 5 6 7 8 9 10 11 12 13 14 15 16 17 18 19 20 21 22	1 2 3 4 5 6	1 2 3 4 5 6

Wire colour code  
 BK: Black LG: Light green G: Green L: Blue W: White Y: Yellow SB: Sky blue  
 BR: Brown O: Orange GR: Gray R: Red P: Pink V: Violet

**BACK-UP LAMP AND REVERSE (R) POSITION WARNING BUZZER <AT>**

1

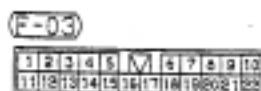
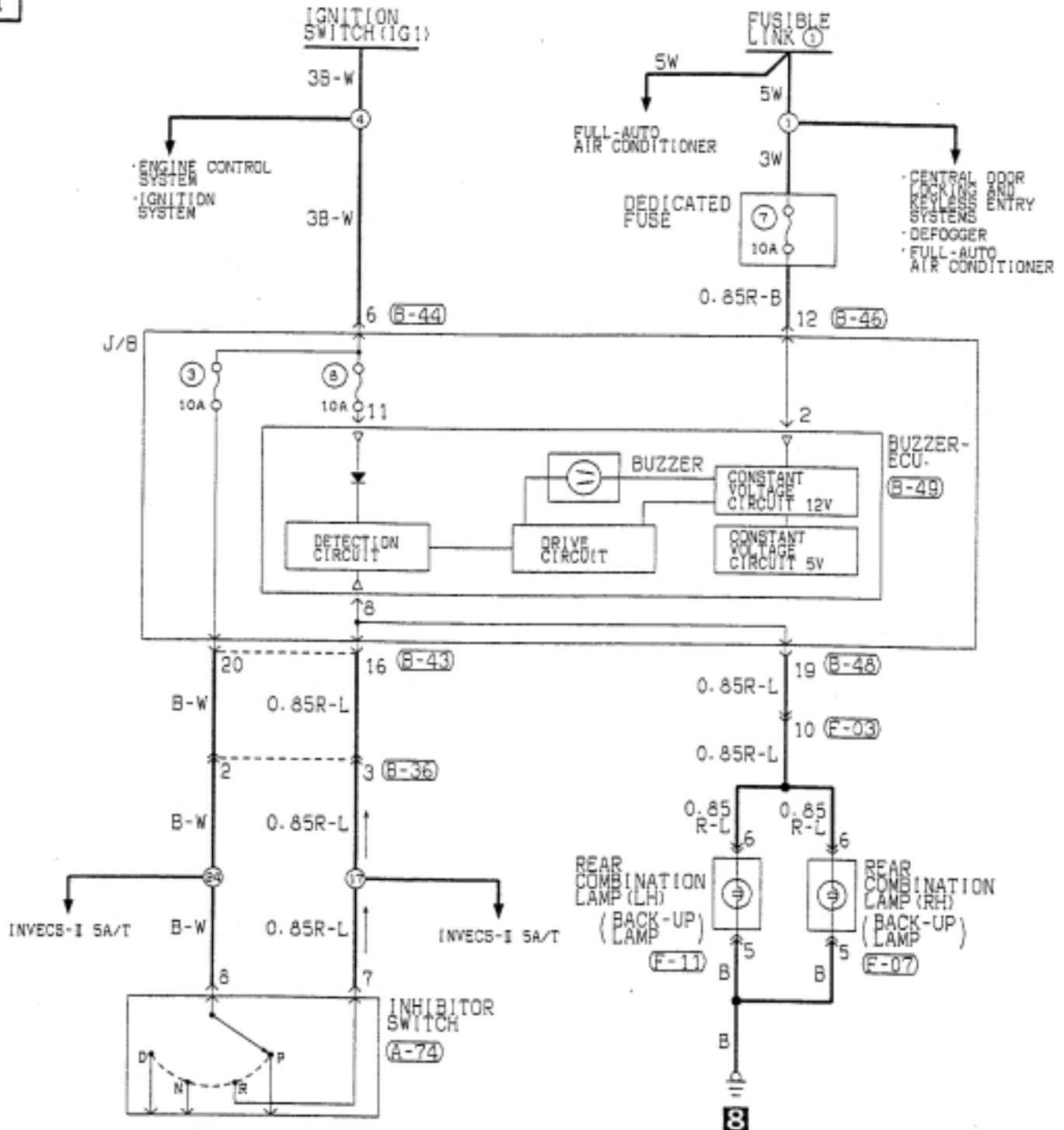

HORN

1

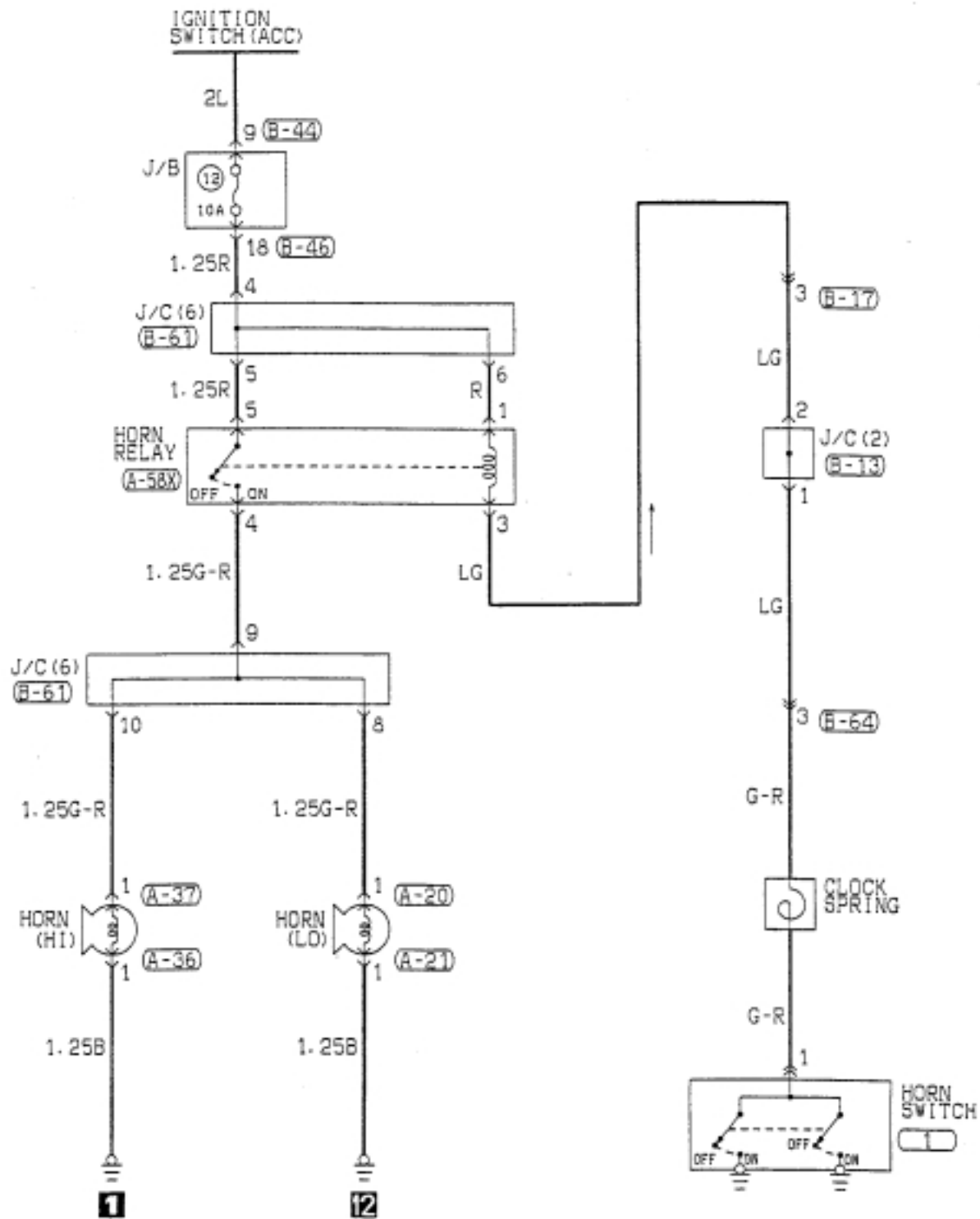

<b>A-20</b> 1 2 3 4 5 6 7 8 9 10 11 12 13 14 15 16 17 18 19 20 21 22 23 24 25 26 27 28 29 30 31 32 33	<b>A-21</b> 1 2 3 4 5 6 7 8 9 10 11 12 13 14 15 16 17 18 19 20 21 22 23 24 25 26 27 28 29 30 31 32 33	<b>A-36</b> 1 2 3 4 5 6 7 8 9 10 11 12 13 14 15 16 17 18 19 20 21 22 23 24 25 26 27 28 29 30 31 32 33	<b>A-37</b> 1 2 3 4 5 6 7 8 9 10 11 12 13 14 15 16 17 18 19 20 21 22 23 24 25 26 27 28 29 30 31 32 33	<b>A-58X</b> 1 2 3 4 5 6 7 8 9 10 11 12 13 14 15 16 17 18 19 20 21 22 23 24 25 26 27 28 29 30 31 32 33	<b>B-13</b> 1 2 3 4 5 6 7 8 9 10 11 12 13 14 15 16 17 18 19 20 21 22 23 24 25 26 27 28 29 30 31 32 33	<b>B-17</b> 1 2 3 4 5 6 7 8 9 10 11 12 13 14 15 16 17 18 19 20 21 22 23 24 25 26 27 28 29 30 31 32 33	<b>B-44</b> 1 2 3 4 5 6 7 8 9 10 11 12 13 14 15 16 17 18 19 20 21 22 23 24 25 26 27 28 29 30 31 32 33	<b>B-46</b> 1 2 3 4 5 6 7 8 9 10 11 12 13 14 15 16 17 18 19 20 21 22 23 24 25 26 27 28 29 30 31 32 33	<b>B-61</b> 1 2 3 4 5 6 7 8 9 10 11 12 13 14 15 16 17 18 19 20 21 22 23 24 25 26 27 28 29 30 31 32 33	<b>B-64</b> 1 2 3 4 5 6 7 8 9 10 11 12 13 14 15 16 17 18 19 20 21 22 23 24 25 26 27 28 29 30 31 32 33
--	--	--	--	---	--	--	--	--	--	--

Wire colour code  
 B: Black LG: Light green G: Green L: Blue  
 BR: Brown O: Orange GR: Gray R: Red  
 W: White SB: Sky blue P: Pink Y: Yellow  
 V: Violet



METER AND GAUGE

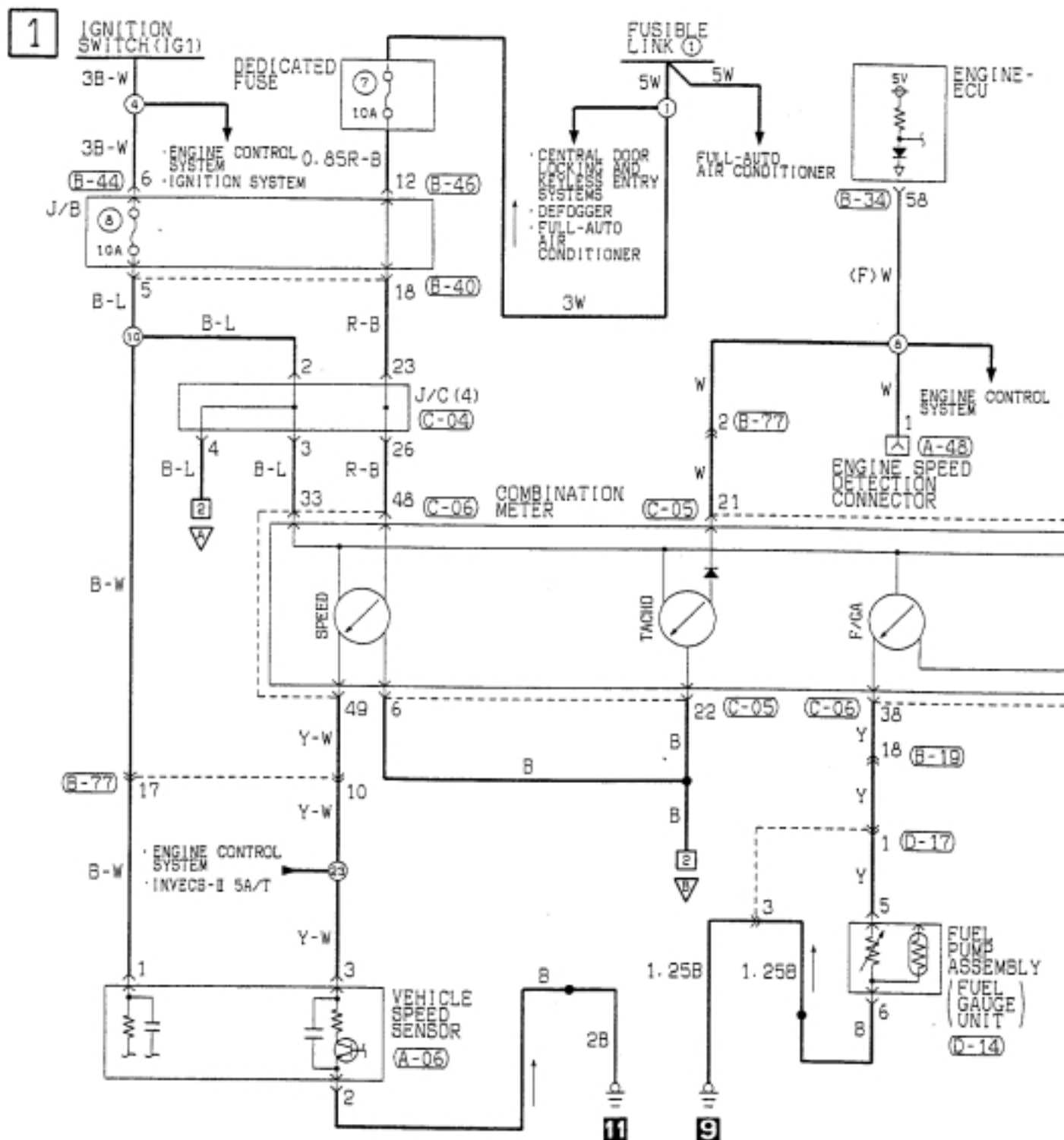

- A-06 

1	2	3	4	5	6	7	8	9	10	11	12
13	14	15	16	17	18	19	20	21	22	23	24
25	26	27	28	29	30	31	32	33	34	35	36
- A-26 

1
---
- A-48 

1
---
- B-14 

1	2	3	4	5	6	7	8	9	10	11	12
13	14	15	16	17	18	19	20	21	22	23	24
25	26	27	28	29	30	31	32	33	34	35	36
- B-19 

1	2	3	4	5	6	7	8	9	10
11	12	13	14	15	16	17	18	19	20
21	22	23	24	25	26	27	28	29	30
- B-34 

1	2	3	4	5	6	7	8	9	10
11	12	13	14	15	16	17	18	19	20
21	22	23	24	25	26	27	28	29	30
- B-40 

1	2	3	4	5	6	7	8	9	10
11	12	13	14	15	16	17	18	19	20
21	22	23	24	25	26	27	28	29	30
- C-05 

1	2	3	4	5	6	7	8	9	10	11	12
13	14	15	16	17	18	19	20	21	22	23	24
25	26	27	28	29	30	31	32	33	34	35	36
- C-06 

1	2	3	4	5	6	7	8	9	10	11	12
13	14	15	16	17	18	19	20	21	22	23	24
25	26	27	28	29	30	31	32	33	34	35	36
- D-14 

1	2	3	4	5	6	7	8	9	10
11	12	13	14	15	16	17	18	19	20
21	22	23	24	25	26	27	28	29	30
- D-17 

1	2	3	4	5	6	7	8	9	10
11	12	13	14	15	16	17	18	19	20
21	22	23	24	25	26	27	28	29	30

2

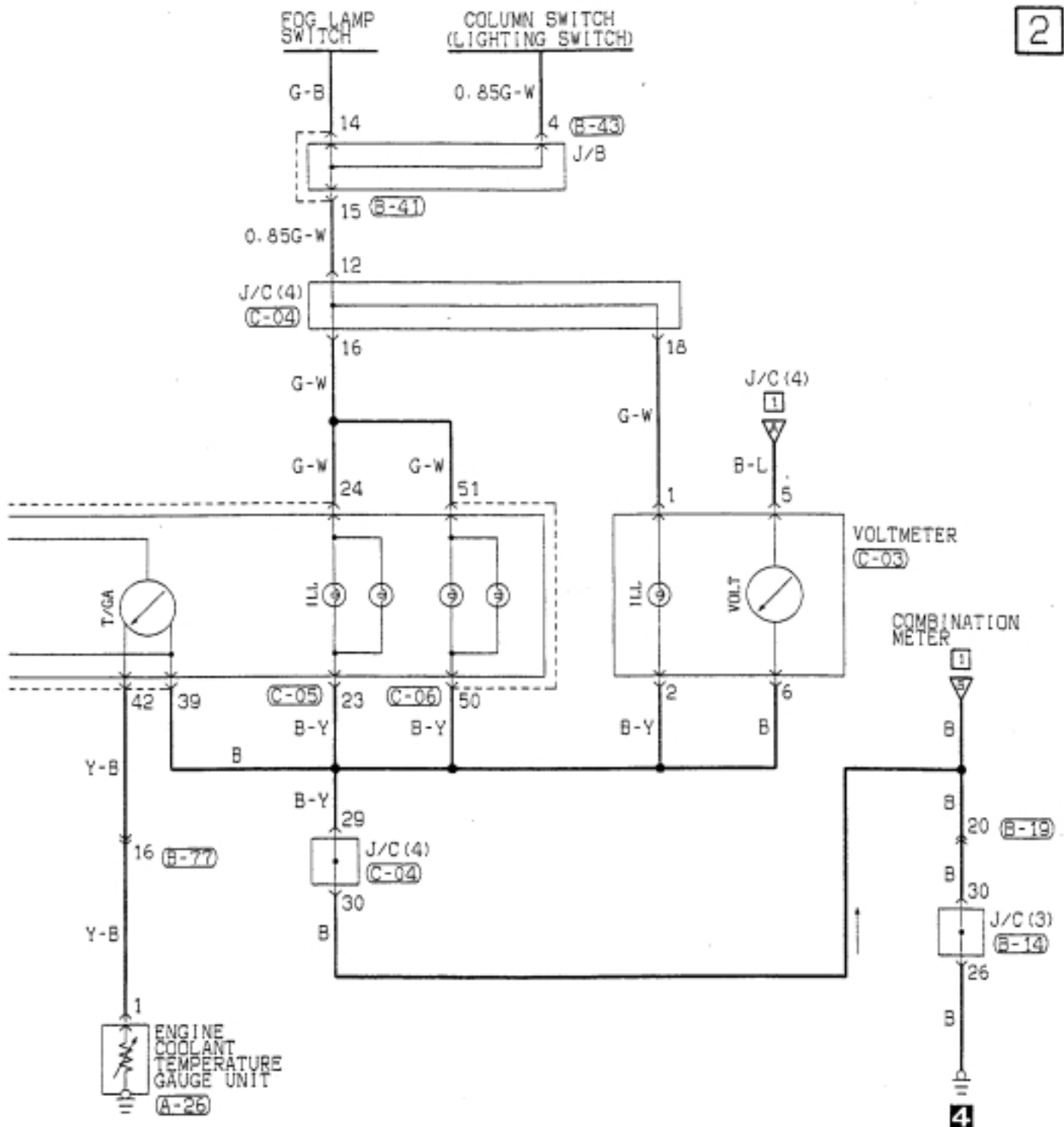

B-43

B-44

B-46

B-77

C-03

C-04

1	2	3	4	5	6	7	8	9
10	11	12	13	14	15	16	17	18
19	20	21	22	23	24	25	26	27

1	2	3	4	5	6	7	8	9
10	11	12	13	14	15	16	17	18
19	20	21	22	23	24	25	26	27

1	2	3	4	5	6	7	8	9
10	11	12	13	14	15	16	17	18
19	20	21	22	23	24	25	26	27

1	2	3	4	5	6	7	8	9
10	11	12	13	14	15	16	17	18
19	20	21	22	23	24	25	26	27

1	2	3	4	5	6	7	8	9
10	11	12	13	14	15	16	17	18
19	20	21	22	23	24	25	26	27

1	2	3	4	5	6	7	8	9	10	11	12	13	14	15	16	17	18	19	20	21	22	23	24	25	26	27	28	29	30	31	32	33	34	35	36	37	38	39	40	41	42	43	44	45	46	47	48	49	50	51	52	53	54	55	56	57	58	59	60	61	62	63	64	65	66	67	68	69	70	71	72	73	74	75	76	77	78	79	80	81	82	83	84	85	86	87	88	89	90	91	92	93	94	95	96	97	98	99	100
---	---	---	---	---	---	---	---	---	----	----	----	----	----	----	----	----	----	----	----	----	----	----	----	----	----	----	----	----	----	----	----	----	----	----	----	----	----	----	----	----	----	----	----	----	----	----	----	----	----	----	----	----	----	----	----	----	----	----	----	----	----	----	----	----	----	----	----	----	----	----	----	----	----	----	----	----	----	----	----	----	----	----	----	----	----	----	----	----	----	----	----	----	----	----	----	----	----	----	-----

Wire colour code  
 BK:Black LG:Light green G:Green L:Blue W:White Y:Yellow SB:Sky blue  
 BR:Brown O:Orange GR:Gray R:Red P:Pink V:Violet

OIL PRESSURE WARNING LAMP  
FUEL WARNING LAMP

1

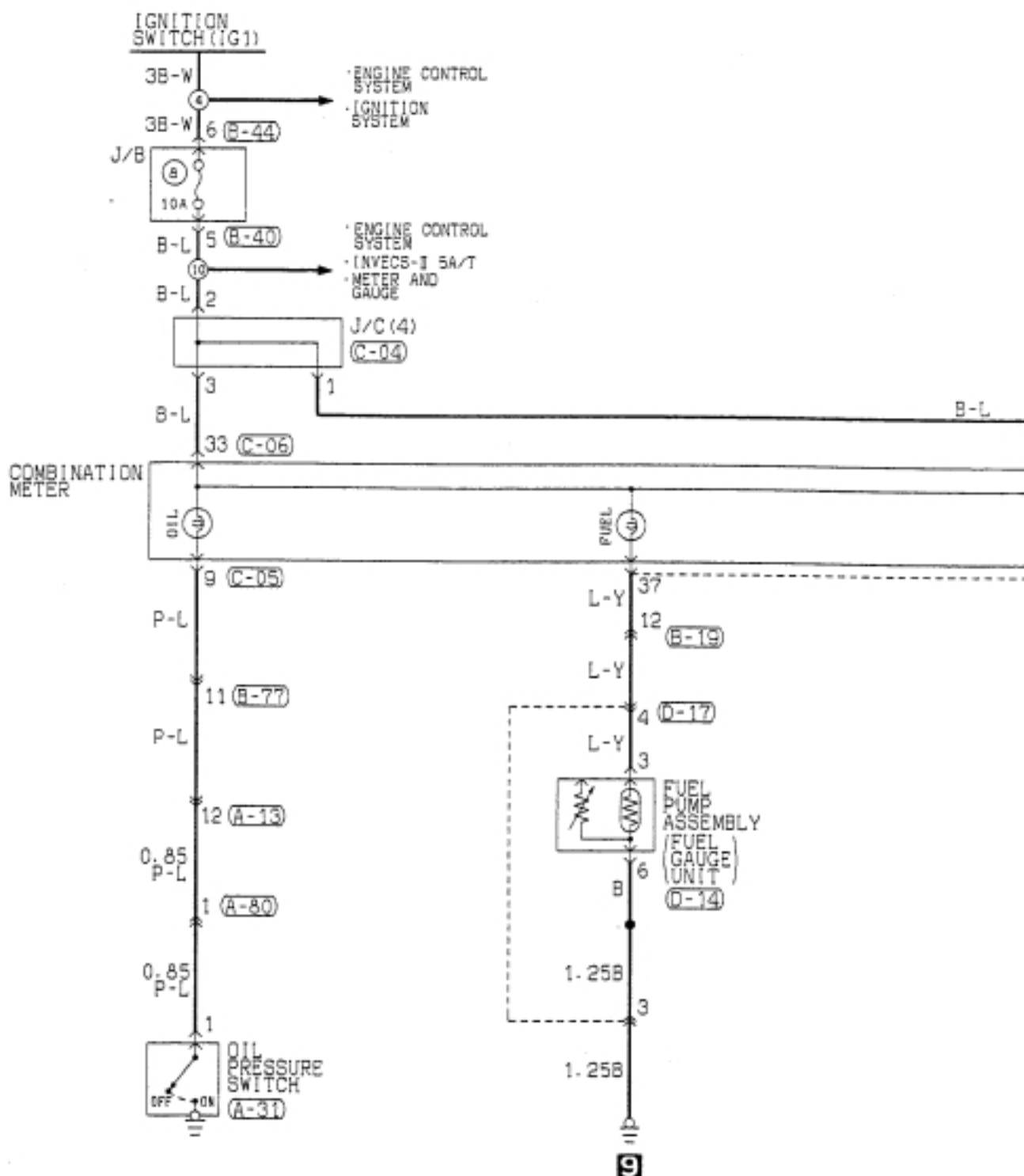

**BRAKE WARNING LAMP  
SEAT BELT WARNING LAMP**

2

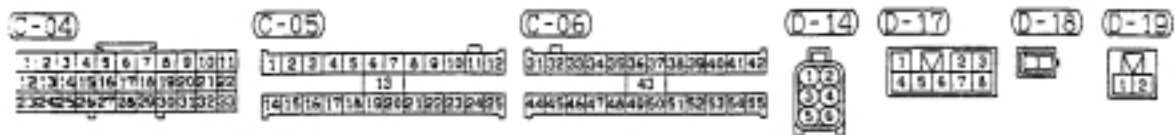
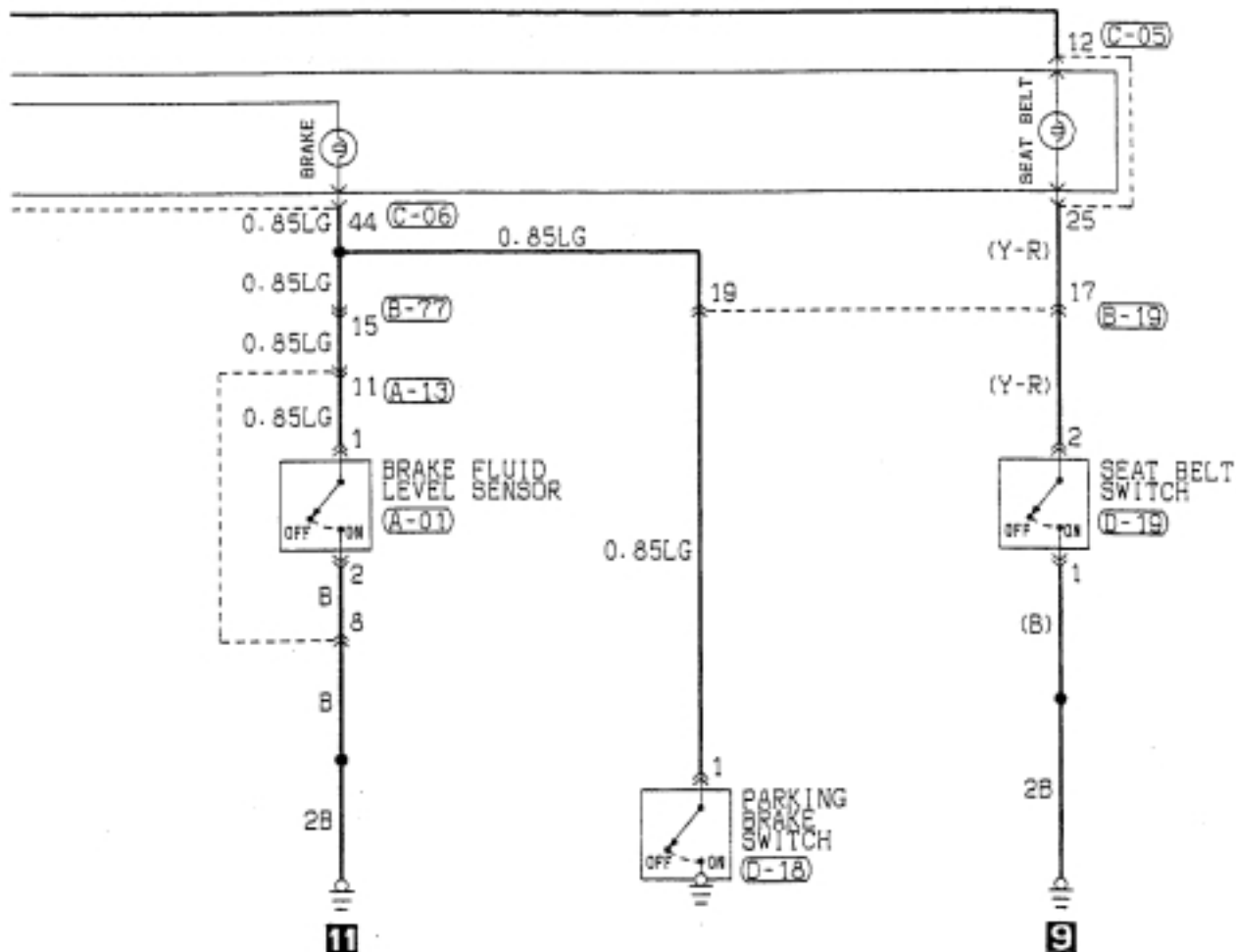

Wire colour code  
 BK:Black LG:Light green G:Green L:Blue W:White Y:Yellow SB:Sky blue  
 BR:Brown O:Orange GR:Gray R:Red P:Pink V:Violet

## POWER WINDOWS

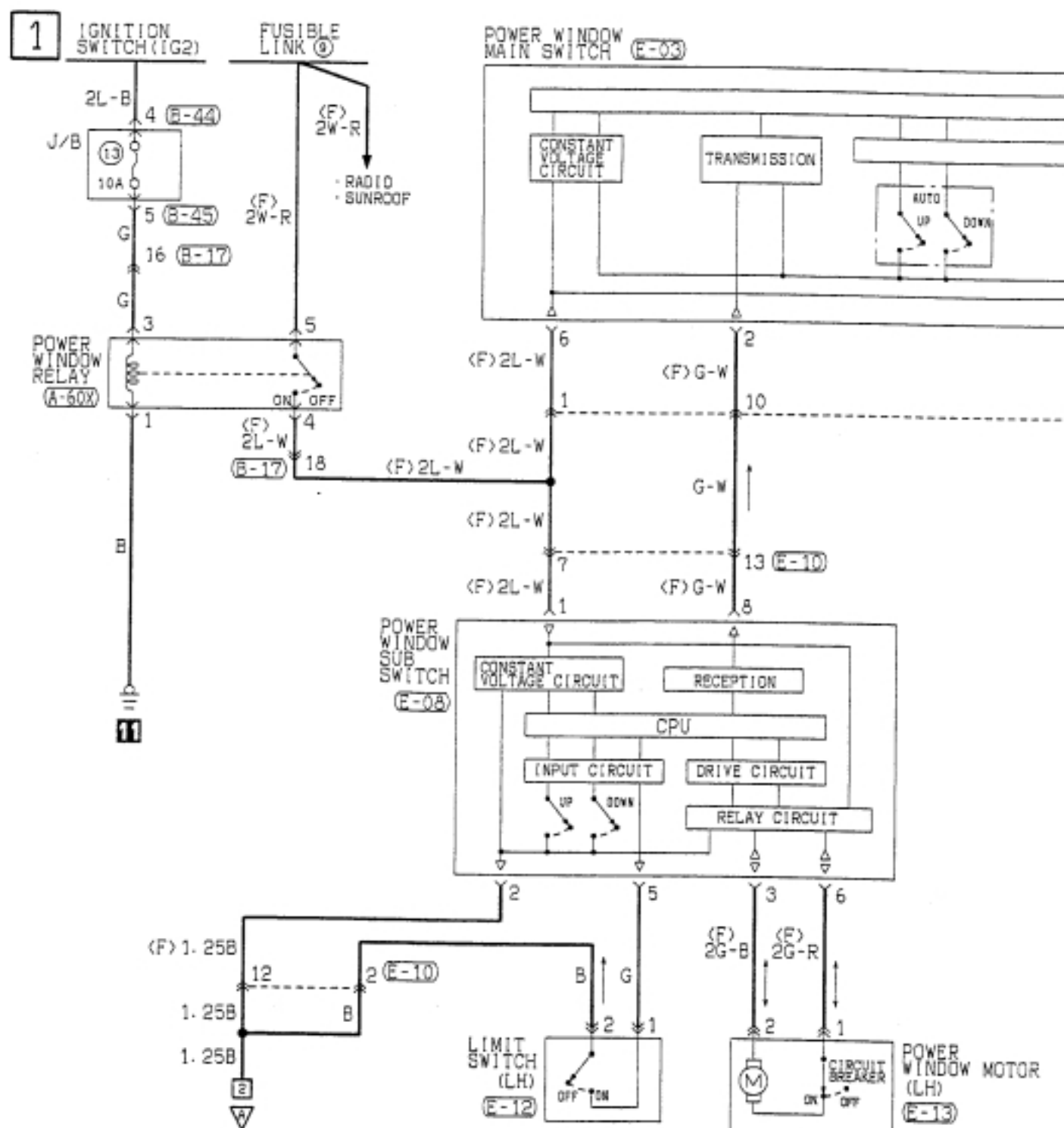

2

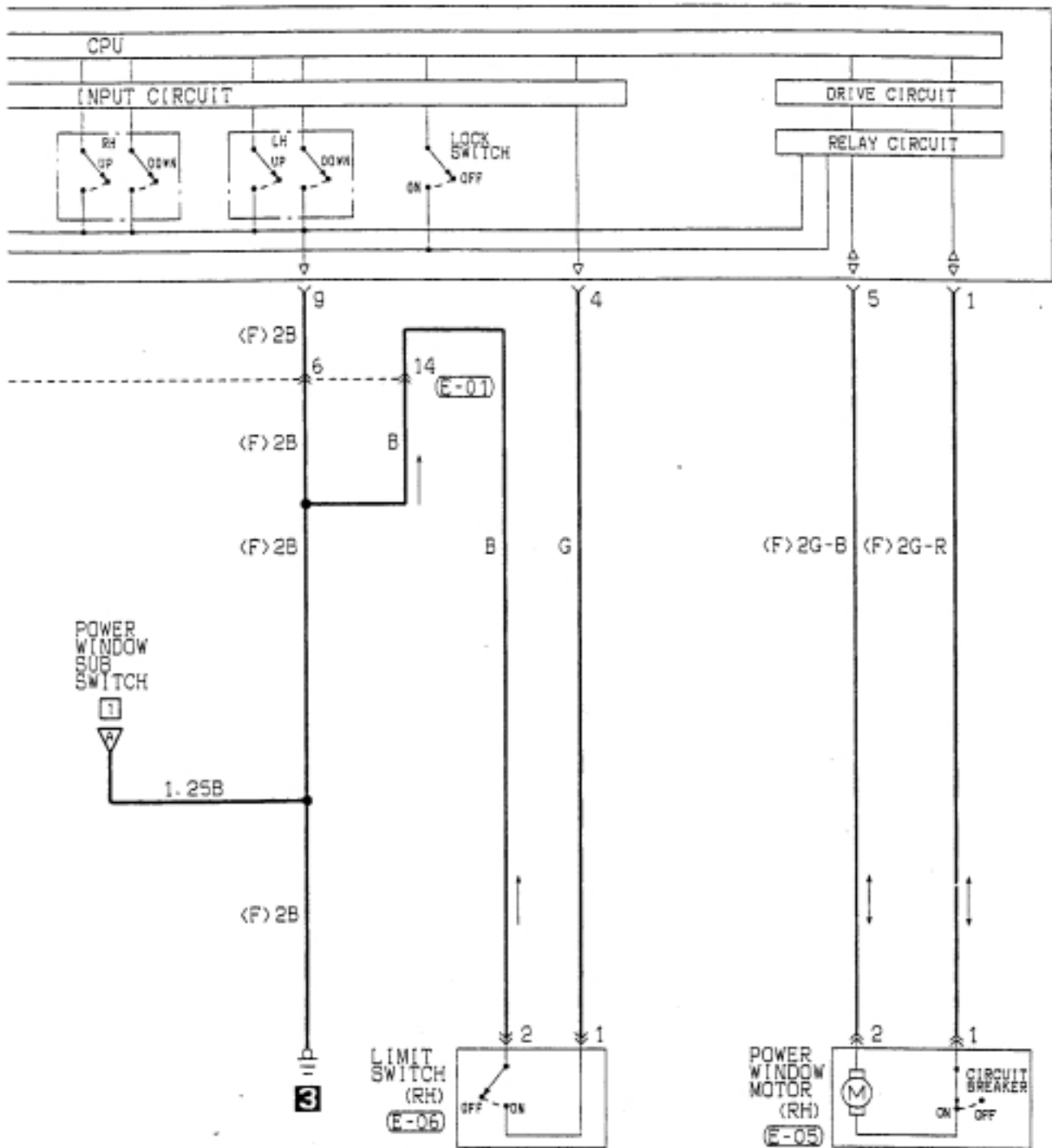

E-08 E-10 E-12 E-13



Wire colour code  
 BK:Black LG:Light green G:Green L:Blue W:White Y:Yellow SB:Sky blue  
 BR:Brown O:Orange GR:Gray R:Red P:Pink V:Violet

CENTRAL DOOR LOCKING AND KEYLESS ENTRY SYSTEMS

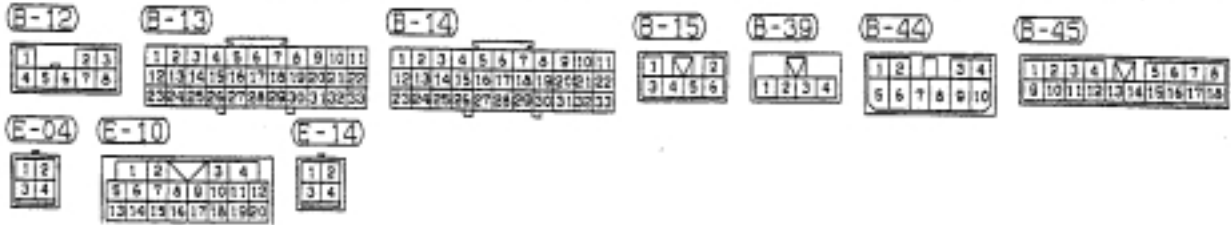
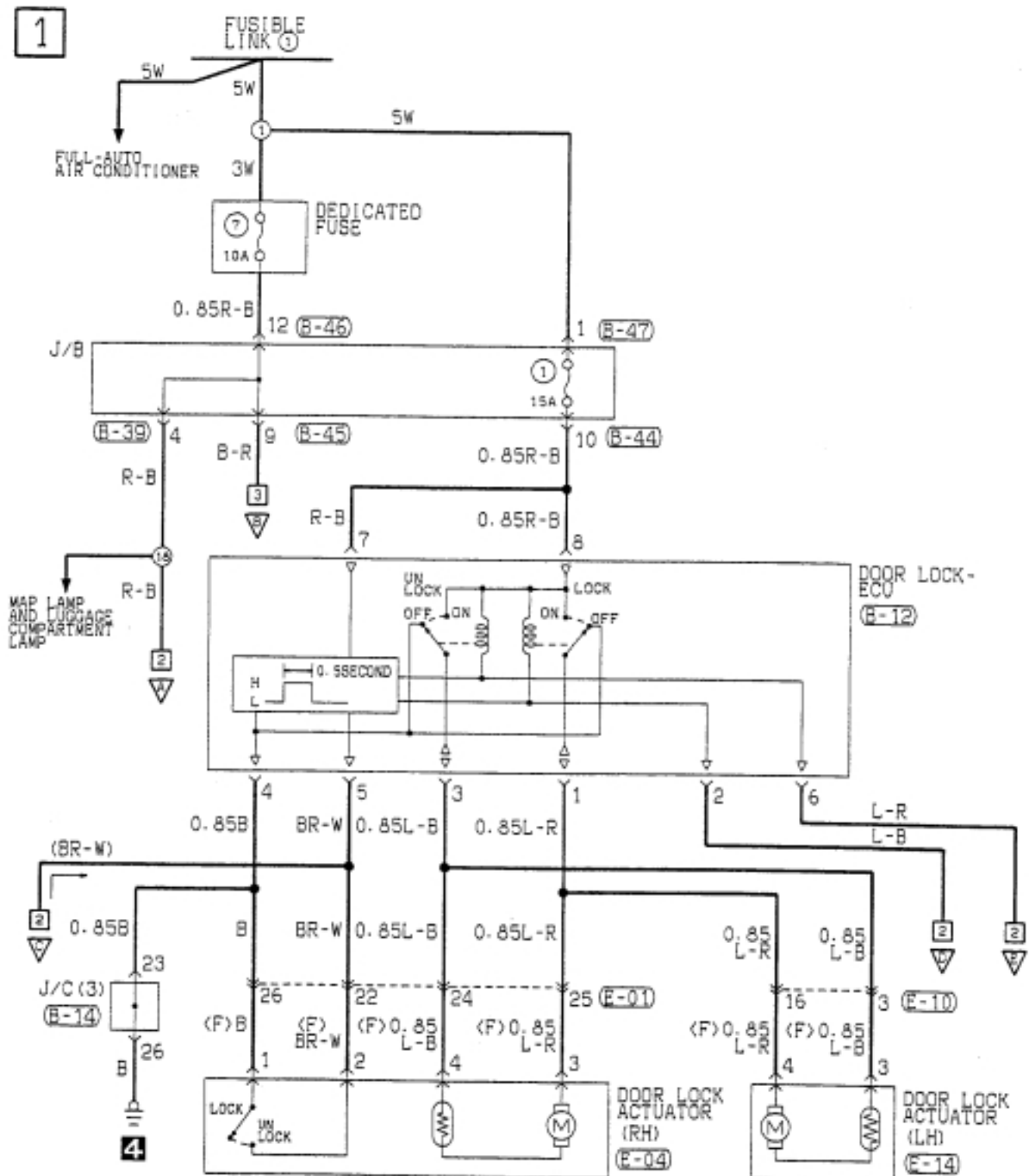

2

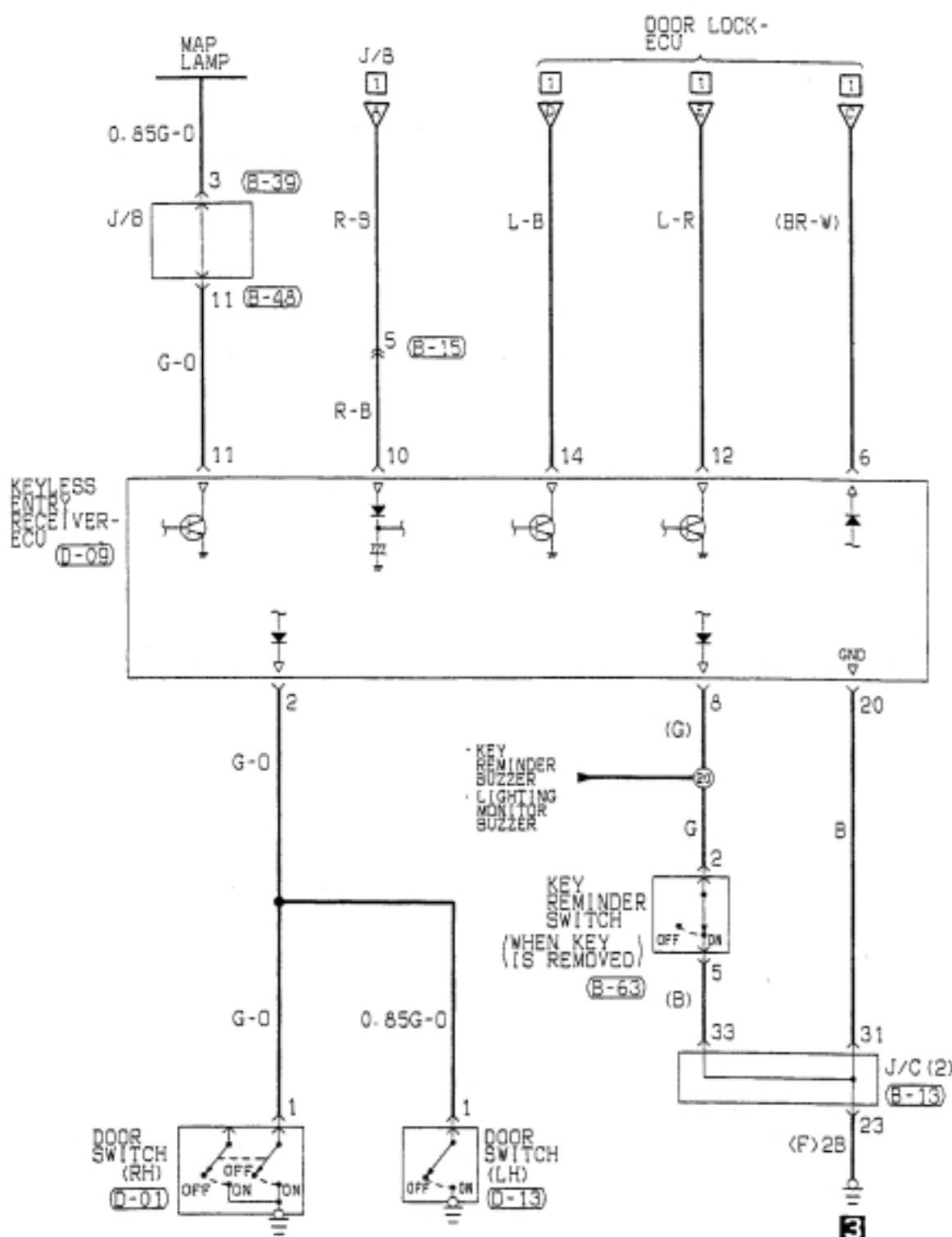

3



Wire colour code  
 B : Black    LG : Light green    G : Green    L : Blue    W : White    Y : Yellow    SB : Sky blue  
 BR : Brown    O : Orange    GR : Gray    R : Red    P : Pink    V : Violet



CENTRAL DOOR LOCKING AND KEYLESS ENTRY SYSTEMS (CONTINUED)

3

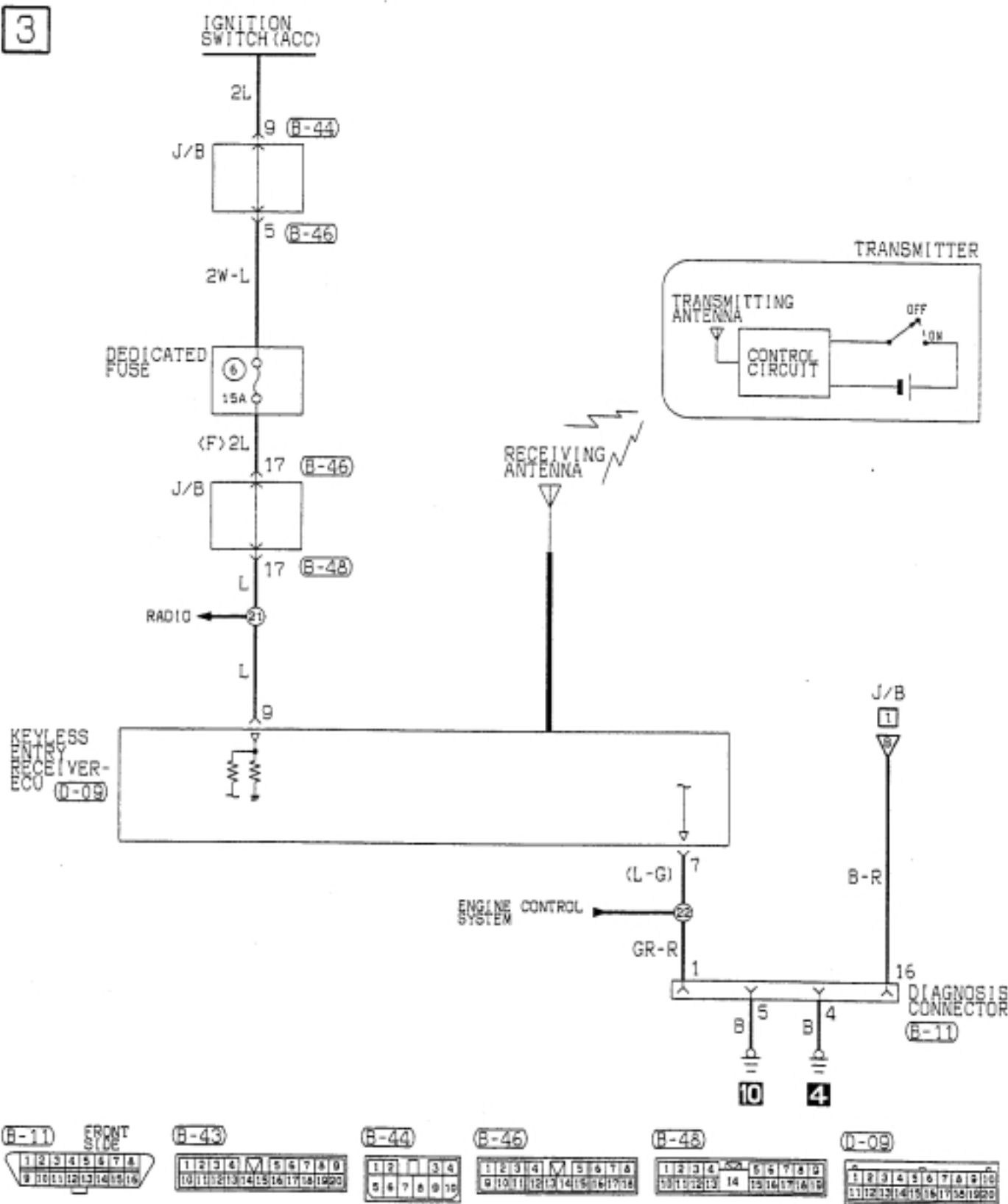

Wire colour code  
 B:Black LG:Light green G:Green L:Blue W:White Y:Yellow SB:Sky blue  
 BR:Brown O:Orange GR:Gray R:Red P:Pink V:Violet

---

NOTES

FULL-AUTO AIR CONDITIONER

1

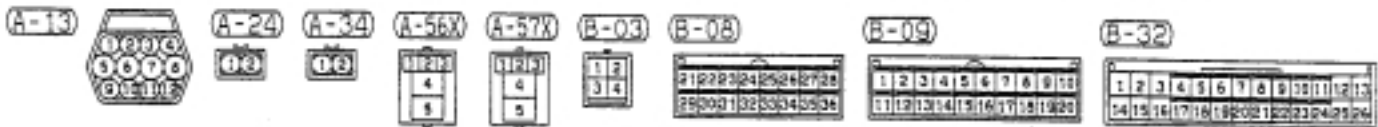
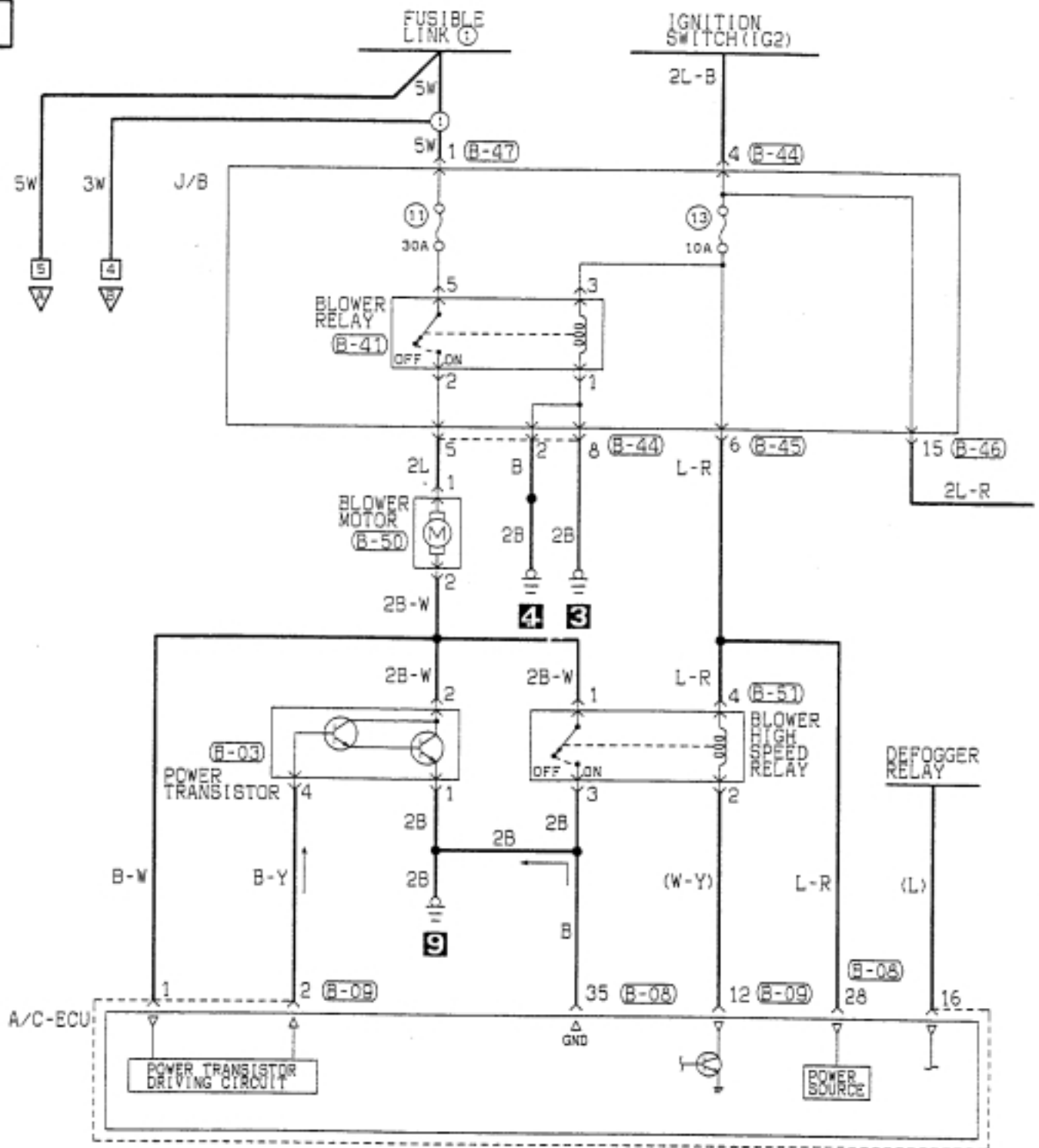

2

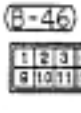
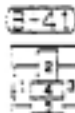
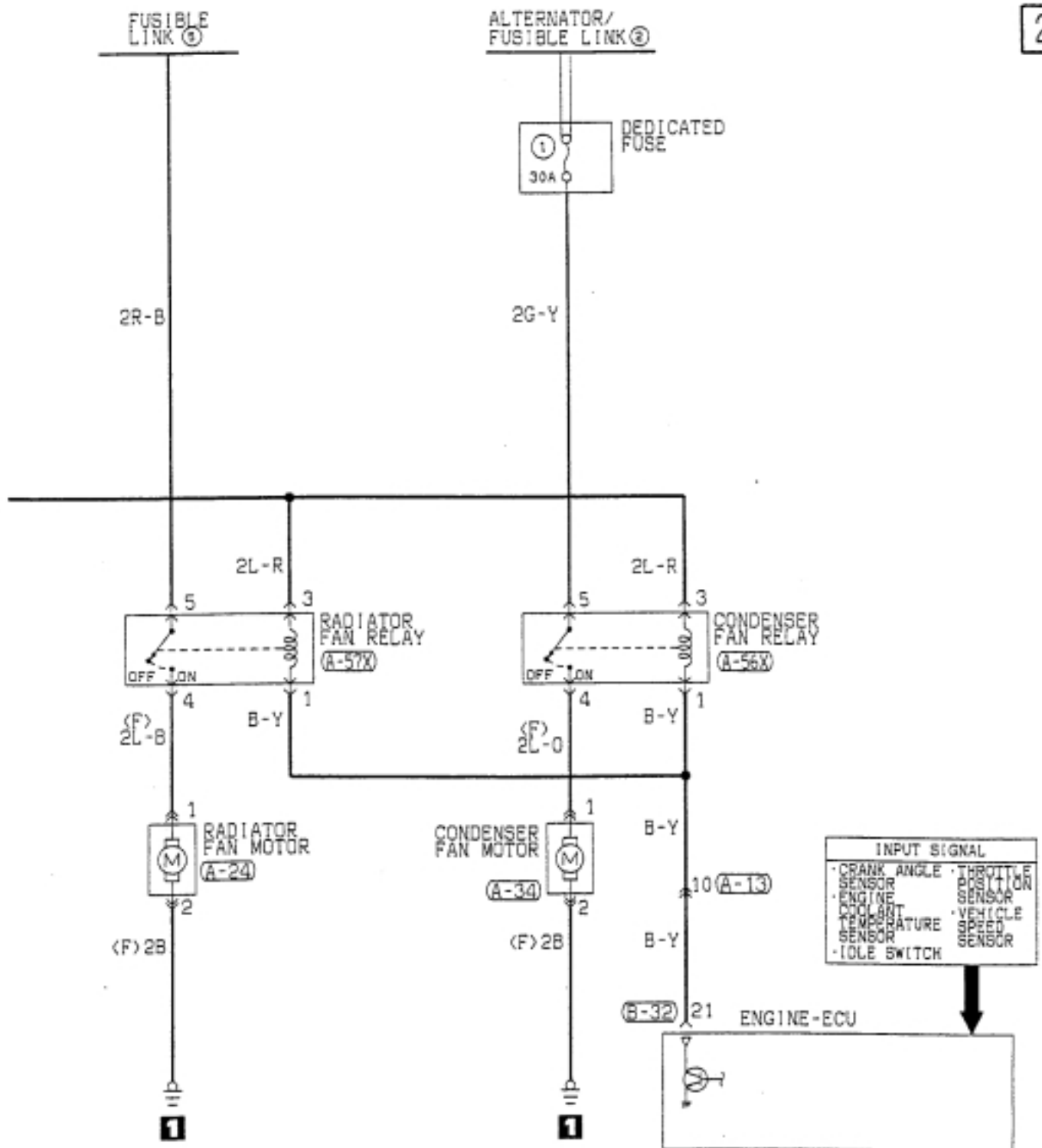

Wire colour code  
 BK:Black LG:Light green G:Green L:Blue W:White Y:Yellow SB:Sky blue  
 BR:Brown O:Orange GR:Gray R:Red P:Pink V:Violet

FULL-AUTO AIR CONDITIONER (CONTINUED)

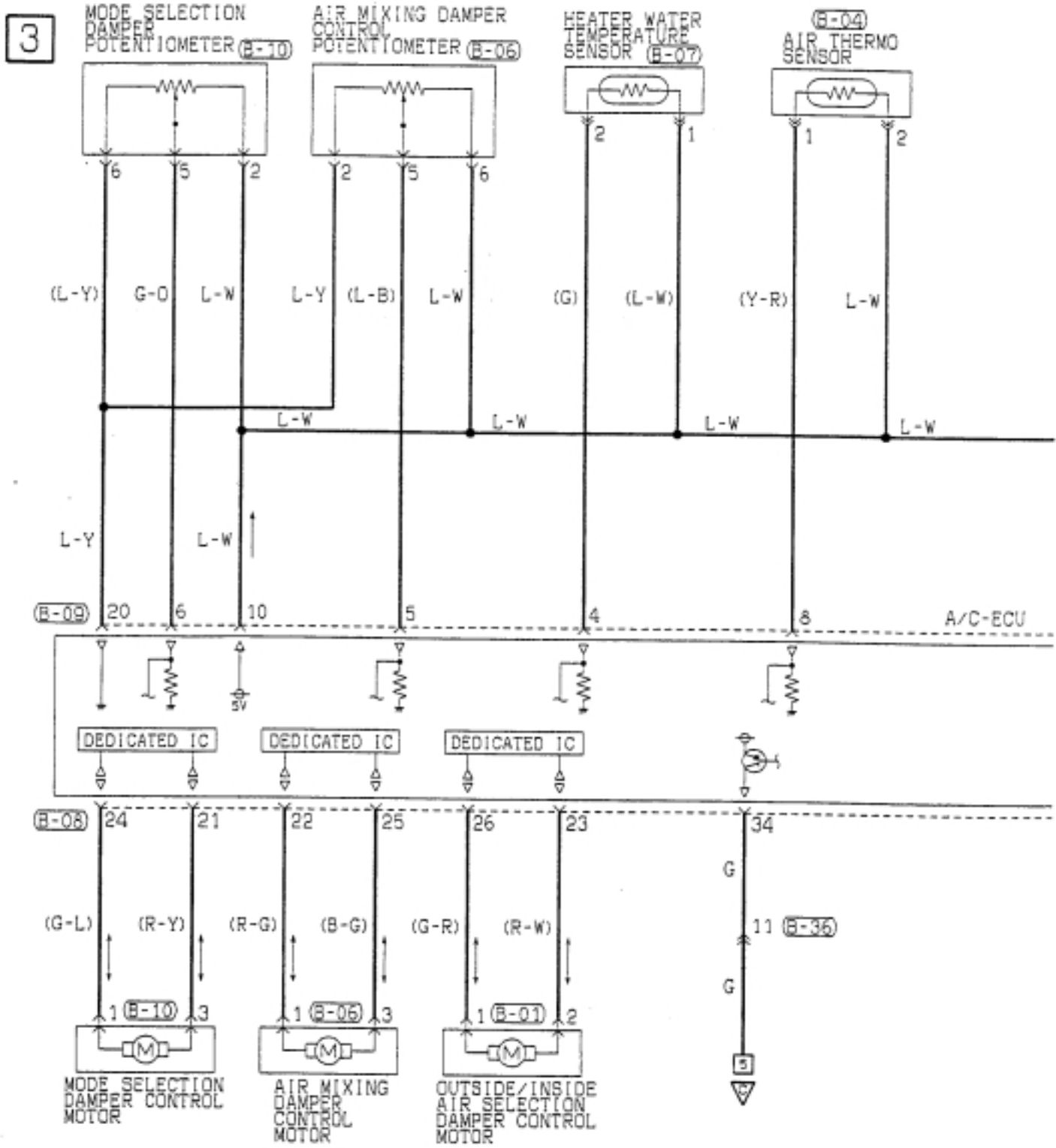

- (A-35) (B-01) (B-04) (B-05) (B-06) (B-07) (B-08) (B-09) (B-10) (B-11) FRONT SIDE
- |   |   |   |         |       |                    |                          |                        |                        |                        |
|---|---|---|---------|-------|--------------------|--------------------------|------------------------|------------------------|------------------------|
| 1 | 1 | 1 | 1 2     | 1 1 2 | 1 1 2              | 1 2 3 4 5 6 7 8 9 10     | 1 1 2 3 4 5 6 7 8 9 10 | 1 1 2                  | 1 2 3 4 5 6 7 8        |
| 2 | 2 | 2 | 3 4 5 6 | 1 1 2 | 2 3 4 5 6 7 8 9 10 | 1 1 1 2 3 4 5 6 7 8 9 10 | 3 4 5 6                | 9 10 11 12 13 14 15 16 | 9 10 11 12 13 14 15 16 |
- (B-45) (B-46)
- |                        |                           |
|------------------------|---------------------------|
| 1 2 3 4 5 6 7 8        | 1 2 3 4 5 6 7 8           |
| 9 10 11 12 13 14 15 16 | 9 10 11 12 13 14 15 16 17 |

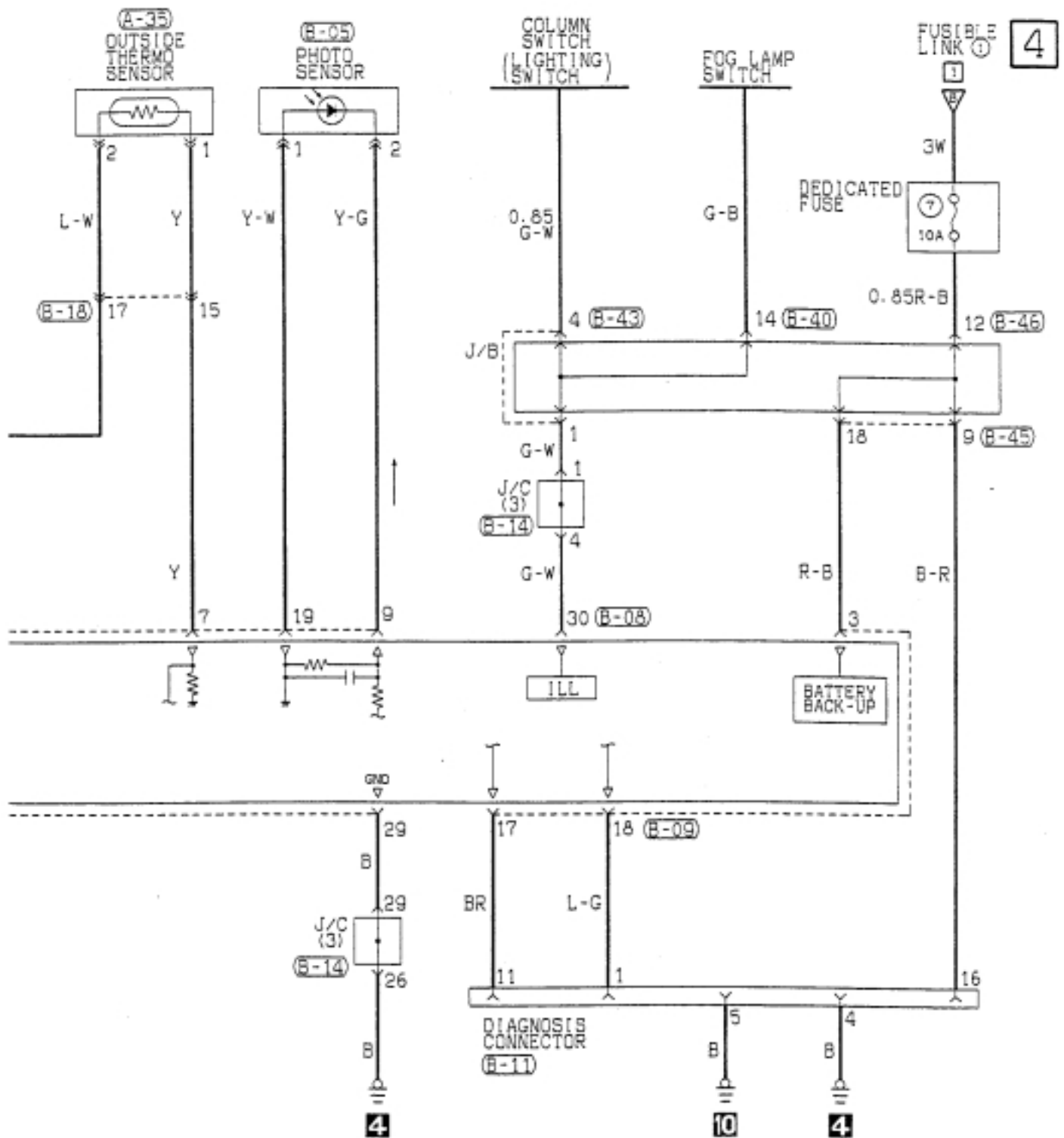

**(B-14)**

1	2	3	4	5	6	7	8	9	10	11
12	13	14	15	16	17	18	19	20	21	22
23	24	25	26	27	28	29	30	31	32	33

**(B-17)**

1	2	3	4	M	6	7	8		
9	10	11	12	13	14	15	16	17	18

**(B-36)**

1	2	3	4	M	6	7	8		
9	10	11	12	13	14	15	16	17	18

**(B-40)**

1	2	3	4	5	M	7	8	9	10		
11	12	13	14	15	16	17	18	19	20	21	22

**(B-43)**

1	2	3	4	M	6	7	8	9		
10	11	12	13	14	15	16	17	18	19	20

Wire colour code  
 BK: Black LG: Light green G: Green L: Blue W: White Y: Yellow SB: Sky blue  
 BR: Brown O: Orange GR: Gray R: Red P: Pink V: Violet

FULL-AUTO AIR CONDITIONER (CONTINUED)

5

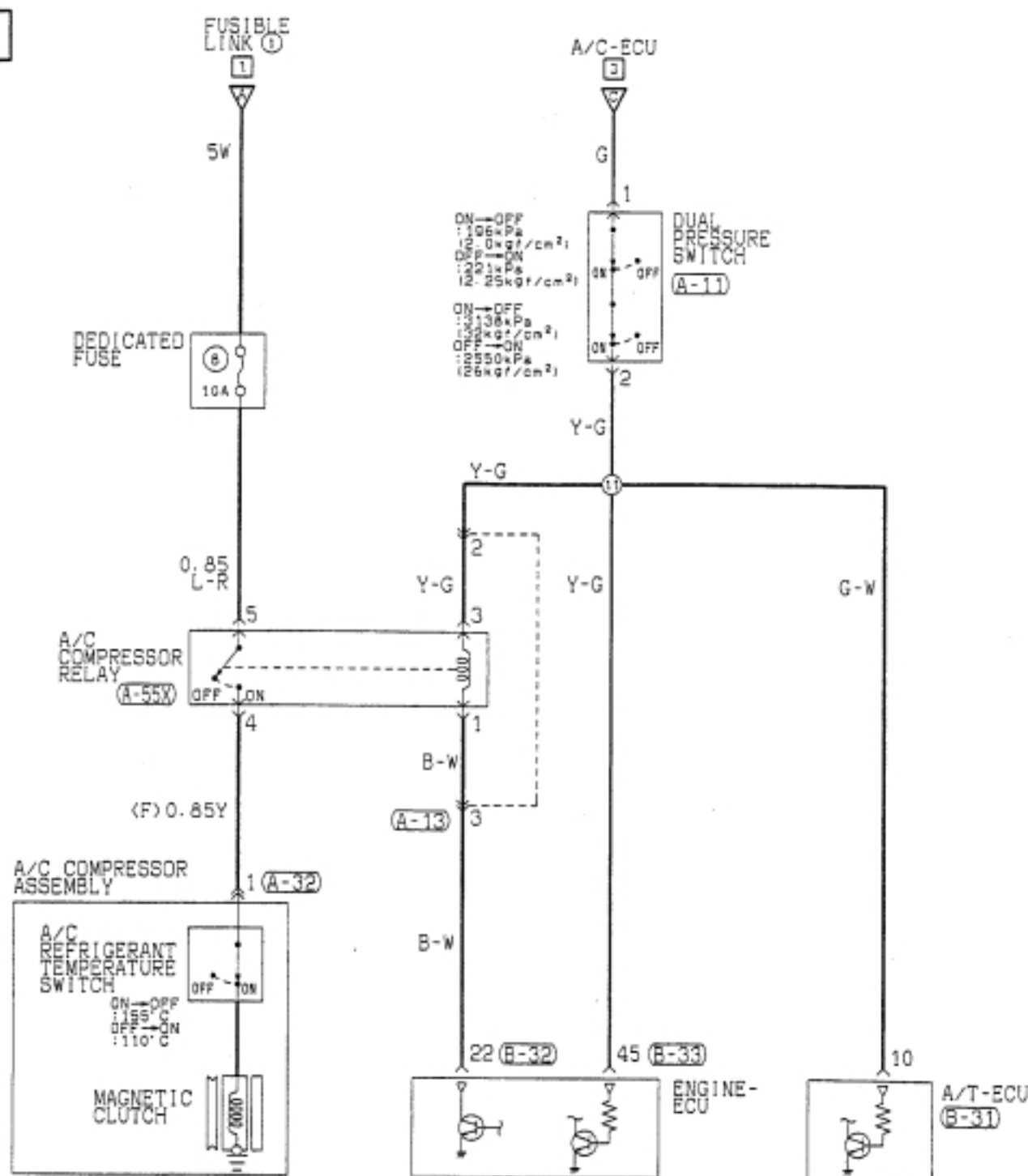

Wire colour code  
 B:Black LG:Light green G:Green L:Blue W:White Y:Yellow SB:Sky blue  
 BR:Brown O:Orange GR:Gray R:Red P:Pink V:Violet

---

NOTES



WINDSHIELD WIPER AND WASHER

1

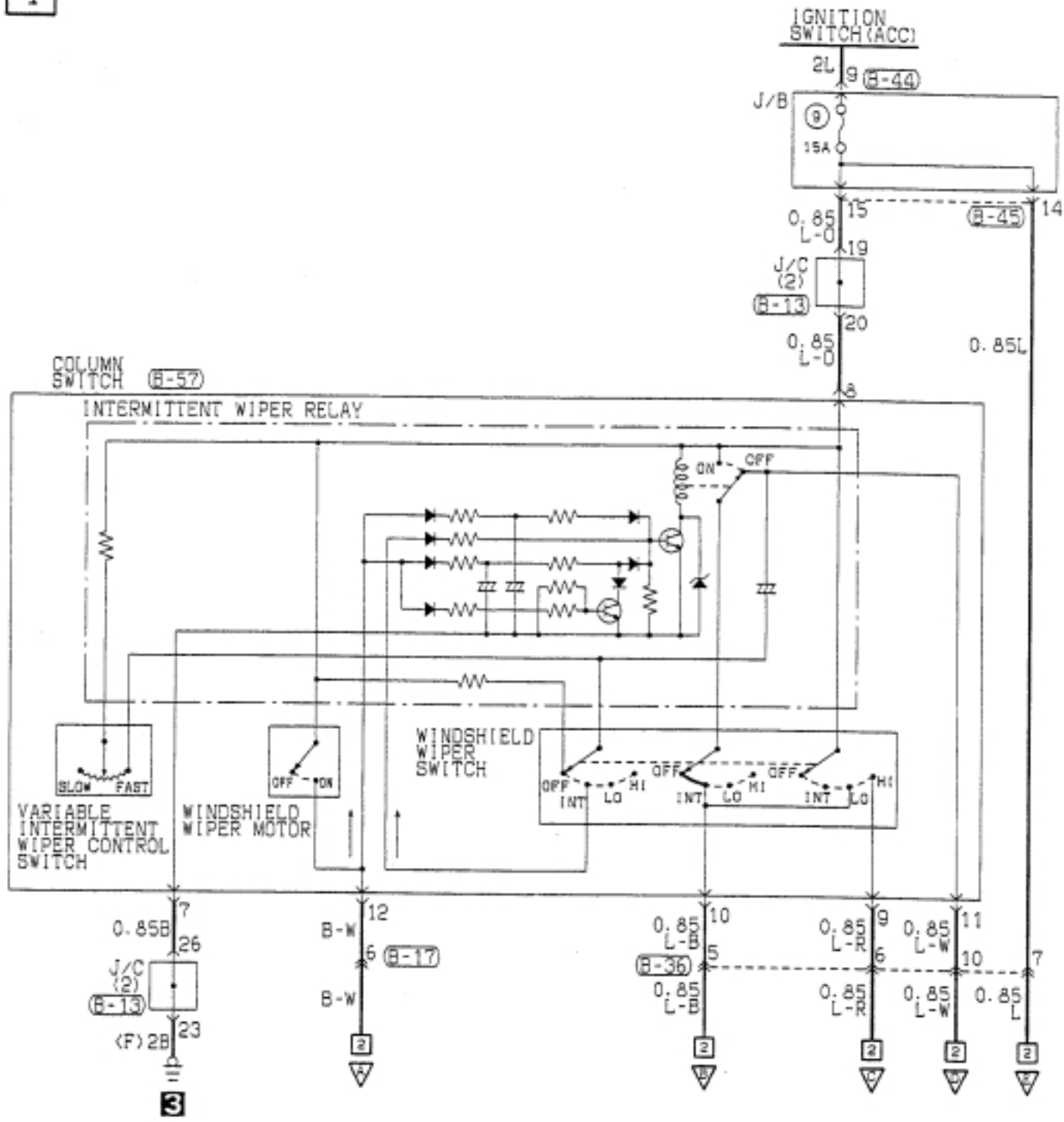

3

A-10

1	2
3	4

A-22

0	2
3	4

B-13

1	2	3	4	5	6	7	8	9	10	11
12	13	14	15	16	17	18	19	20	21	22
23	24	25	26	27	28	29	30	31	32	33

B-17

1	2	3	4	5	6	7	8	9	10	11	12	13	14	15	16	17	18
---	---	---	---	---	---	---	---	---	----	----	----	----	----	----	----	----	----

B-19

1	2	3	4	5	6	7	8	9	10	11	12	13	14	15	16	17	18	19	20	21	22
---	---	---	---	---	---	---	---	---	----	----	----	----	----	----	----	----	----	----	----	----	----

B-36

1	2	3	4	5	6	7	8	9	10	11	12	13	14	15	16	17	18
---	---	---	---	---	---	---	---	---	----	----	----	----	----	----	----	----	----

2

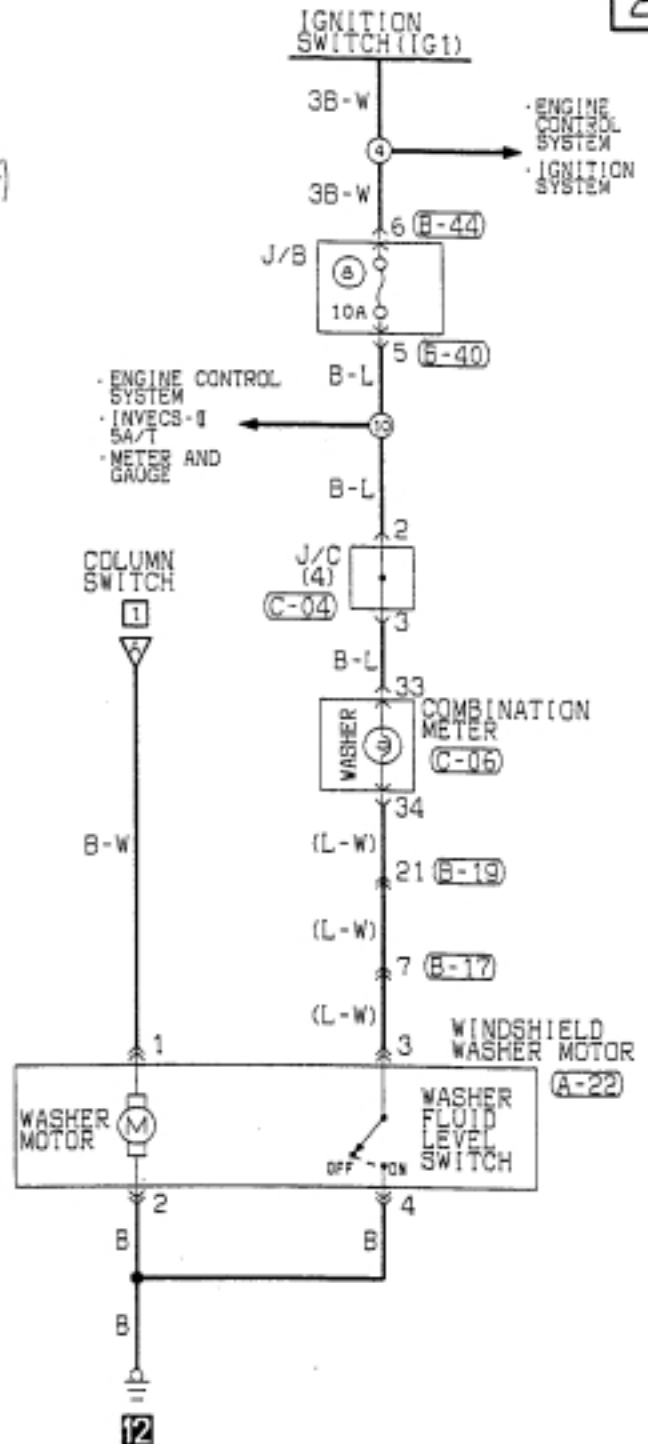
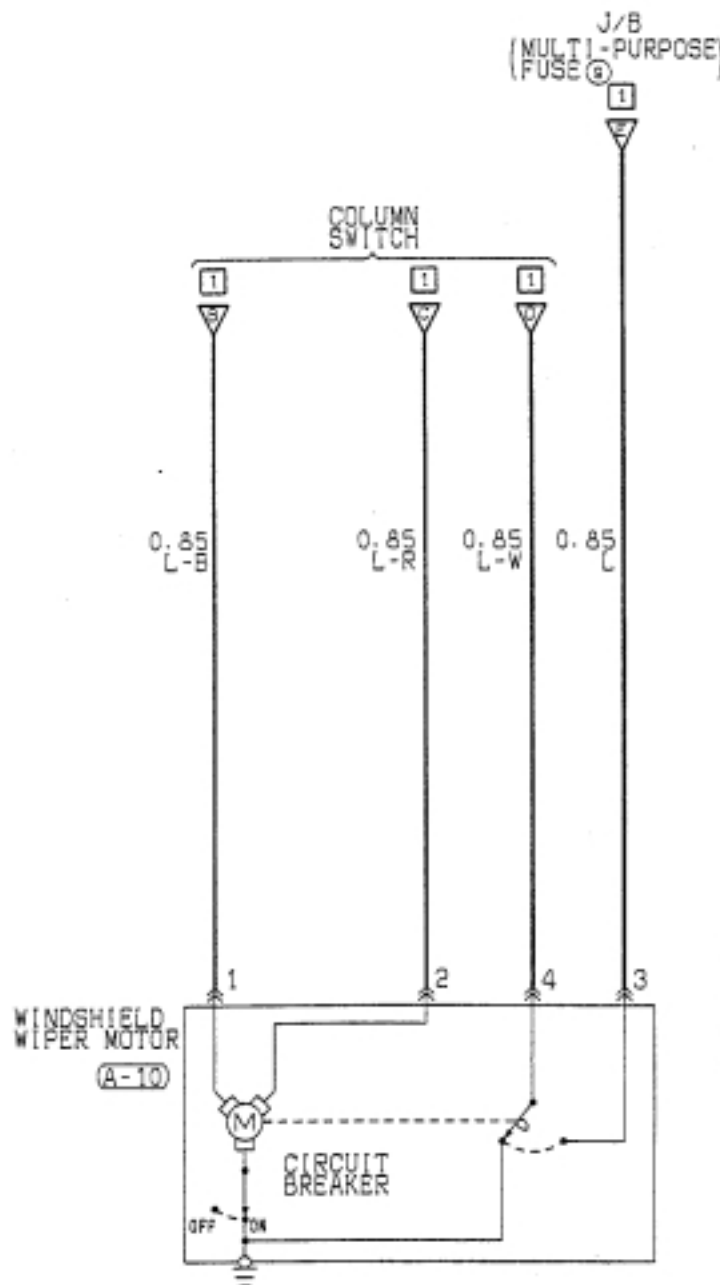

E-40

1	2	3	4	5	M	6	7	8	9	10
11	12	13	14	15	16	17	18	19	20	21

E-44

1	2	1	3	4
5	6	7	8	10

E-45

1	2	3	4	M	5	6	7	8
9	10	11	12	13	14	15	16	17

E-57

1	2	M	3	4	5
6	7	8	9	10	11

C-04

1	2	3	4	5	6	7	8	9	10	11
12	13	14	15	16	17	18	19	20	21	22
23	24	25	26	27	28	29	30	31	32	33

C-05

1	2	3	4	5	6	7	8	9	10	11	12
13	14	15	16	17	18	19	20	21	22	23	24
25	26	27	28	29	30	31	32	33	34	35	36
37	38	39	40	41	42	43	44	45	46	47	48
49	50	51	52	53	54	55	56	57	58	59	60

Wire colour code  
 BB: Black LG: Light green G: Green L: Blue W: White Y: Yellow SB: Sky blue  
 BR: Brown O: Orange GR: Gray R: Red P: Pink V: Violet

REAR WIPER AND WASHER

1

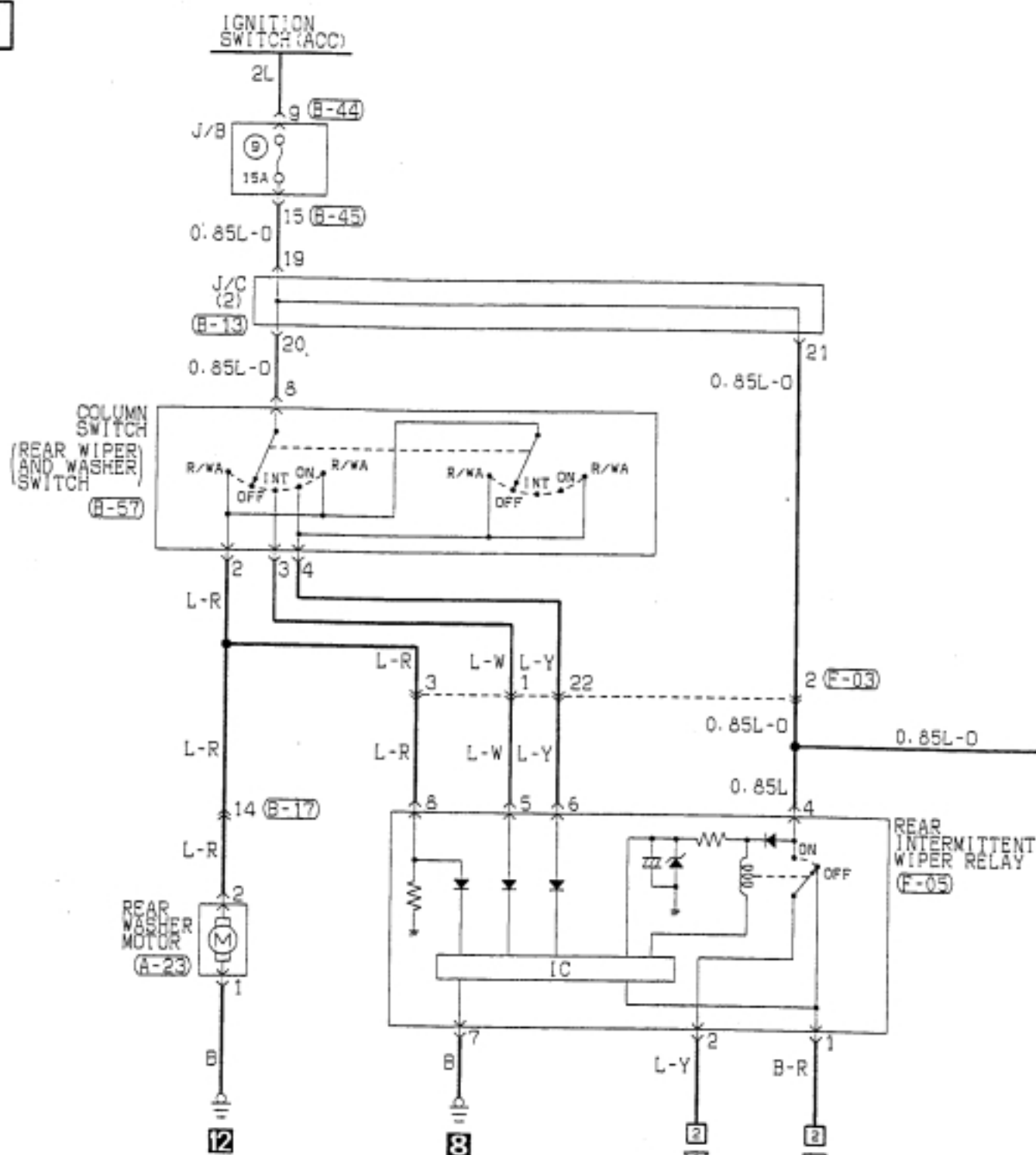

A-23	B-13	B-17	B-44	B-45	B-57
1 2	12 13 14 15 16 17 18 19 20 21 22 23 24 25 26 27 28 29 30 31 32 33	1 2 3 4 5 6 7 8 9 10 11 12 13 14 15 16 17 18	1 2 3 4 5 6 7 8 9 10	1 2 3 4 5 6 7 8 9 10 11 12 13 14 15 16 17 18	1 2 3 4 5 6 7 8 9 10 11 12

2

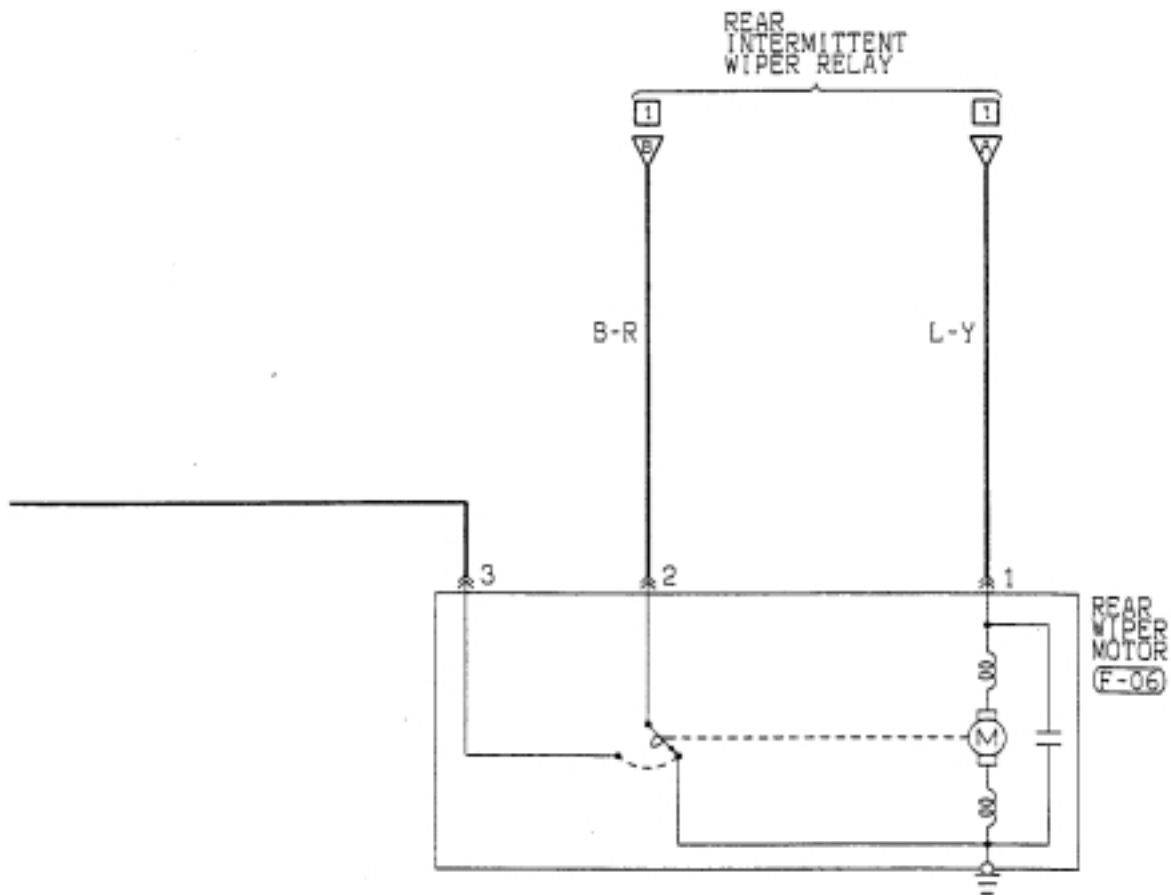

F-00

1	2	3	4	5	6	7	8	9	10
11	12	13	14	15	16	17	18	19	20

F-05

1	2	3
4	5	6

F-06

M		
1	2	3

Wire colour code  
 BK:Black LG:Light green G:Green L:Blue W:White Y:Yellow SB:Sky blue  
 BR:Brown O:Orange GR:Gray R:Red P:Pink V:Violet

DEFOGGER

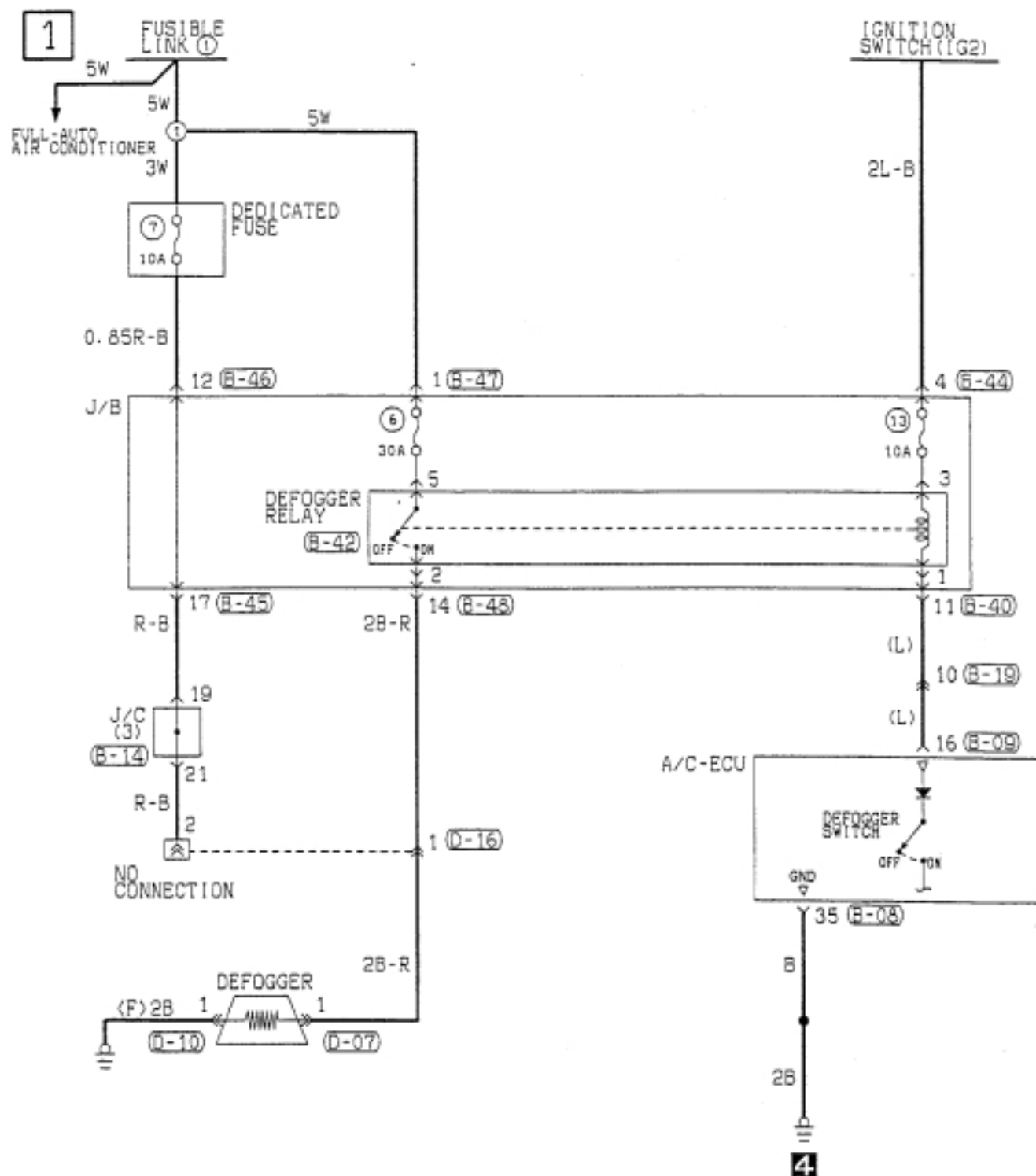

---

NOTES

ELECTRIC RETRACTABLE REMOTE-CONTROLLED MIRROR

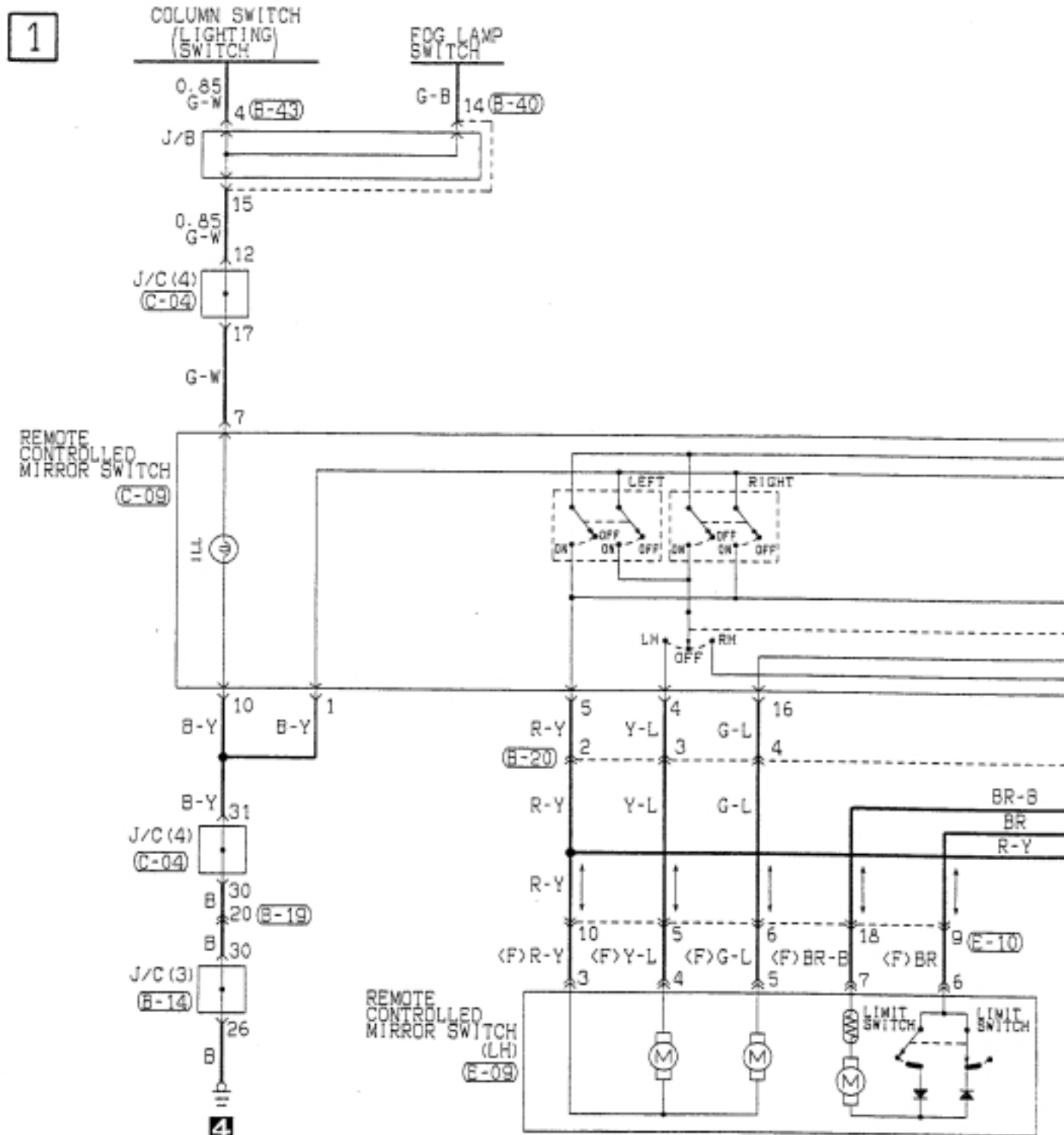

B-13

1	2	3	4	5	6	7	8	9	10	11
12	13	14	15	16	17	18	19	20	21	22
23	24	25	26	27	28	29	30	31	32	33

B-14

1	2	3	4	5	6	7	8	9	10	11
12	13	14	15	16	17	18	19	20	21	22
23	24	25	26	27	28	29	30	31	32	33

B-19

1	2	3	4	5	6	7	8	9	10	11
12	13	14	15	16	17	18	19	20	21	22
23	24	25	26	27	28	29	30	31	32	33

B-20

1	2	3	4	5	6	7	8	9	10	11
12	13	14	15	16	17	18	19	20	21	22
23	24	25	26	27	28	29	30	31	32	33

B-40

1	2	3	4	5	6	7	8	9	10	11
12	13	14	15	16	17	18	19	20	21	22
23	24	25	26	27	28	29	30	31	32	33

E-02

0	1	2	3	4	5	6	7	8	9
---	---	---	---	---	---	---	---	---	---

E-09

0	1	2	3	4	5	6	7	8	9
---	---	---	---	---	---	---	---	---	---

E-10

1	2	3	4
5	6	7	8
9	10	11	12
13	14	15	16
17	18	19	20

2

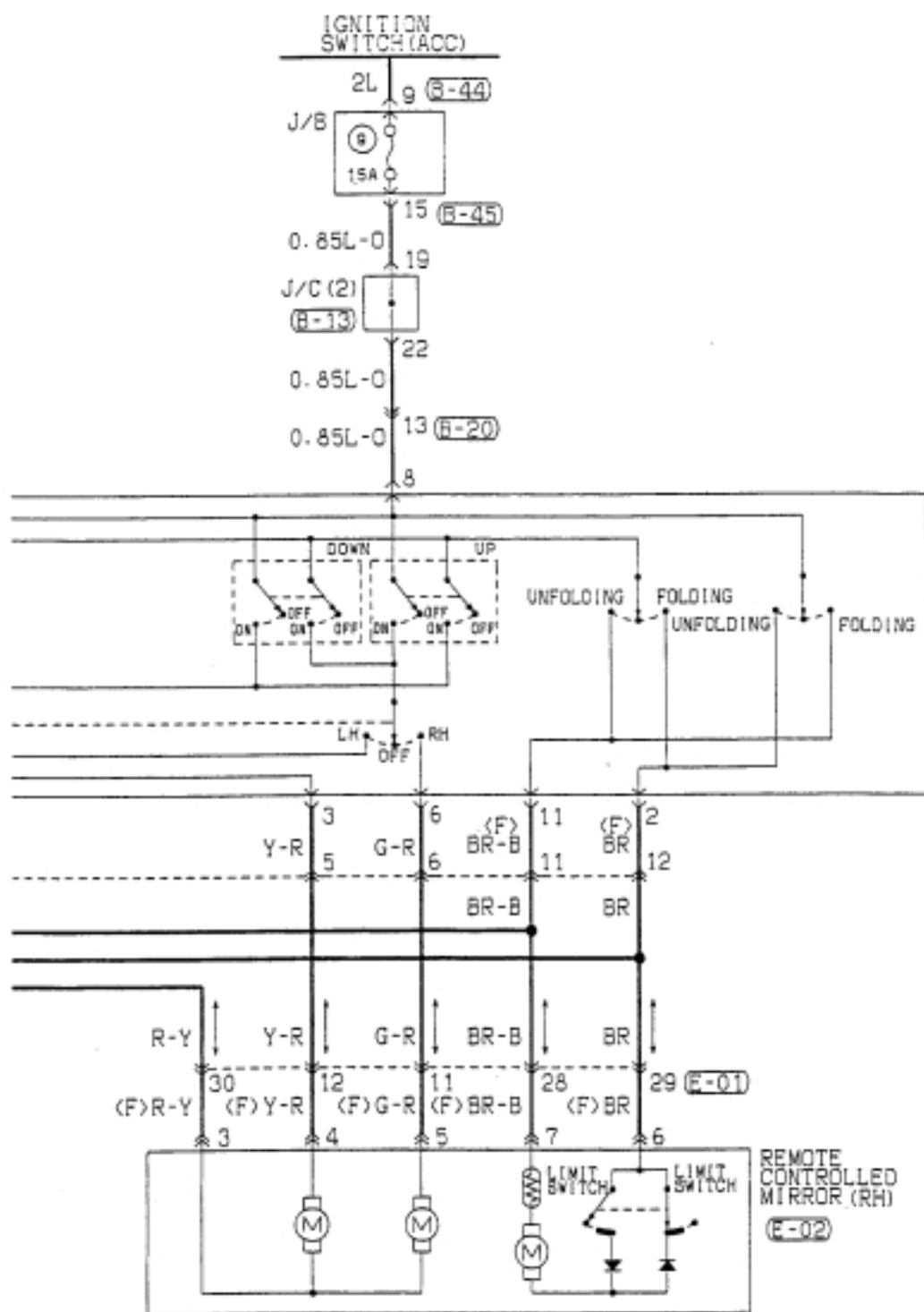

B-43

1	2	3	4	5	6	7	8	9		
10	11	12	13	14	15	16	17	18	19	20

B-44

1	2	3	4		
5	6	7	8	9	10

B-45

1	2	3	4	5	6	7	8	9	10
11	12	13	14	15	16	17	18	19	20

C-04

1	2	3	4	5	6	7	8	9	10	11
12	13	14	15	16	17	18	19	20	21	22
23	24	25	26	27	28	29	30	31	32	33

C-09

1	2	3	4	5	6	7	8
9	10	11	12	13	14	15	16

E-01

1	2	3	4	5	6	7	8	9			
10	11	12	13	14	15	16	17	18	19	20	
21	22	23	24	25	26	27	28	29	30	31	32

Wire colour code  
 B : Black    LG : Light green    G : Green    L : Blue    W : White    Y : Yellow    SB : Sky blue  
 BR : Brown    O : Orange    GR : Gray    R : Red    P : Pink    V : Violet



RADIO

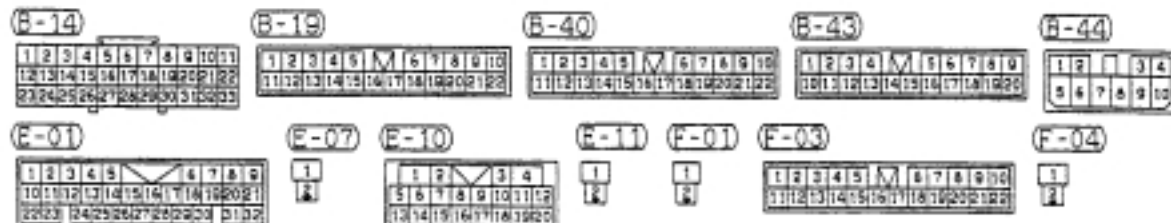
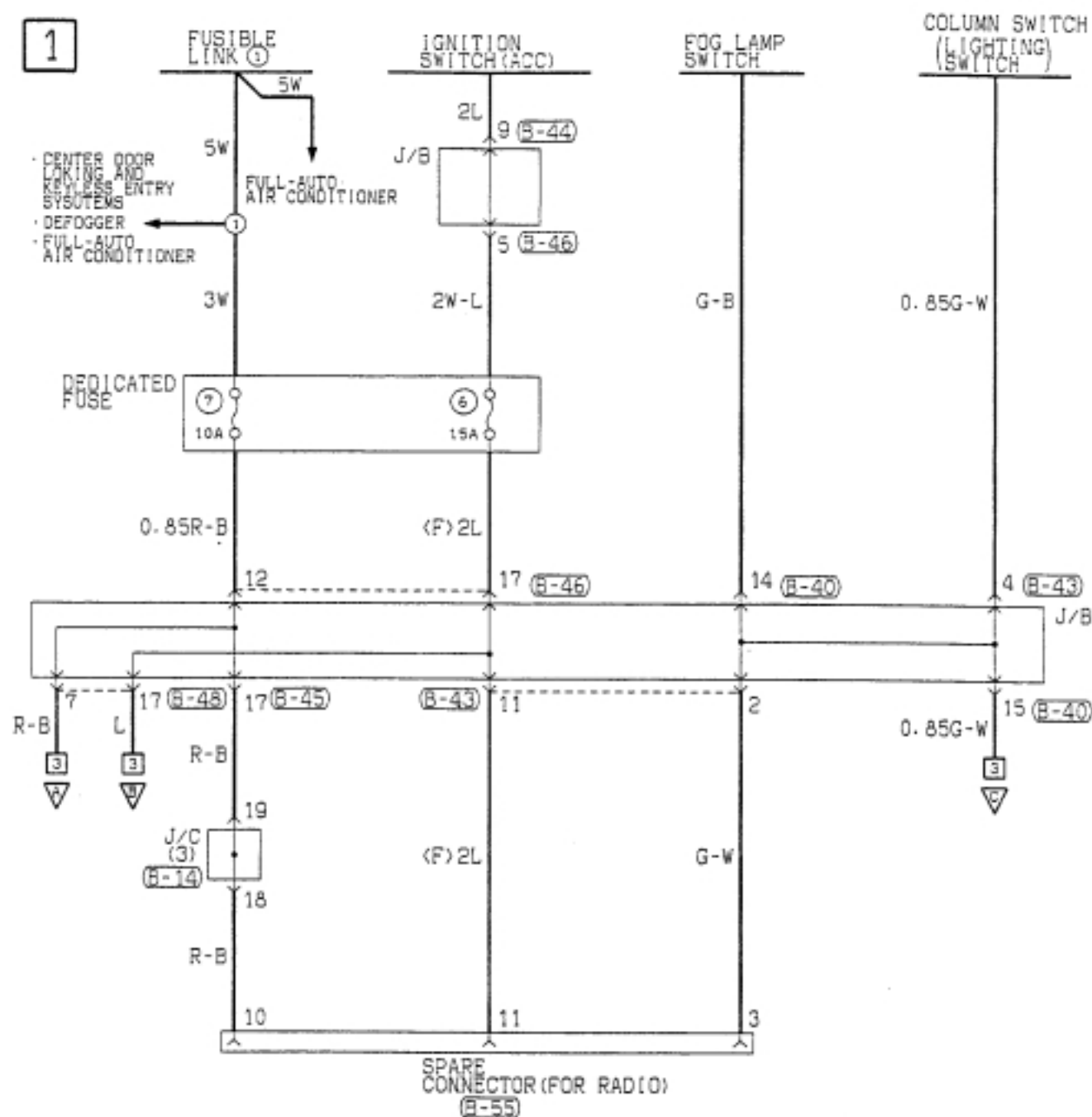

2

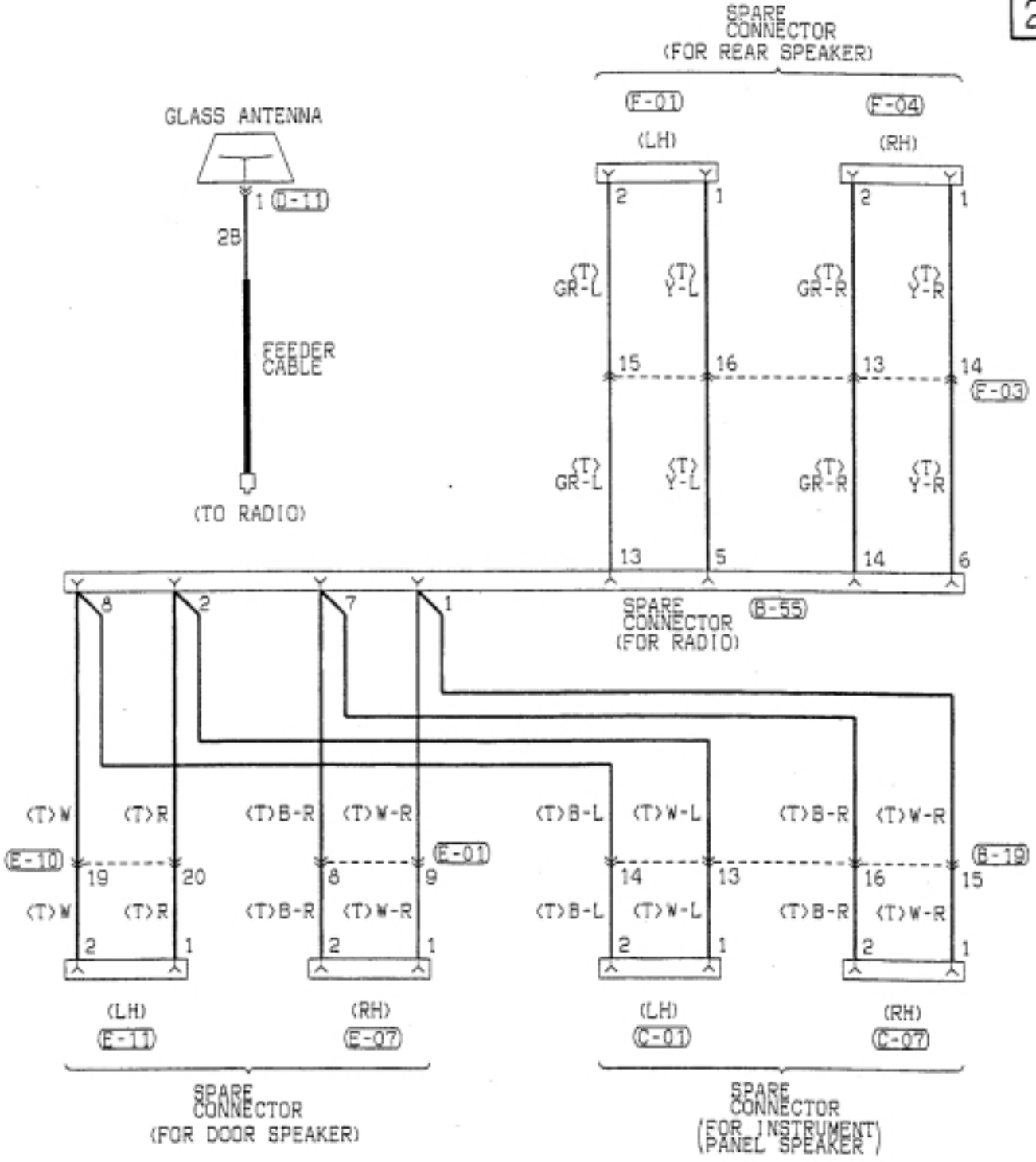

<b>E-45</b>	<b>B-46</b>	<b>B-48</b>	<b>B-55</b>	<b>C-01</b>	<b>C-07</b>	<b>D-11</b>
1 2 3 4 5 6 7 8 9 10 11 12 13 14 15 16 17 18	1 2 3 4 5 6 7 8 9 10 11 12 13 14 15 16 17 18	1 2 3 4 5 6 7 8 9 10 11 12 13 14 15 16 17 18	1 2 3 4 5 6 7 8 9 10 11 12 13 14	1 2 3 4 5 6 7 8	1 2 3 4 5 6 7 8	1 2 3 4 5 6 7 8 9 10 11 12 13 14 15 16 17 18

Wire colour code  
 B : Black    LG : Light green    G : Green    L : Blue    W : White    Y : Yellow    SB : Sky blue  
 BR : Brown    O : Orange    GR : Gray    R : Red    P : Pink    V : Violet



CLOCK

1

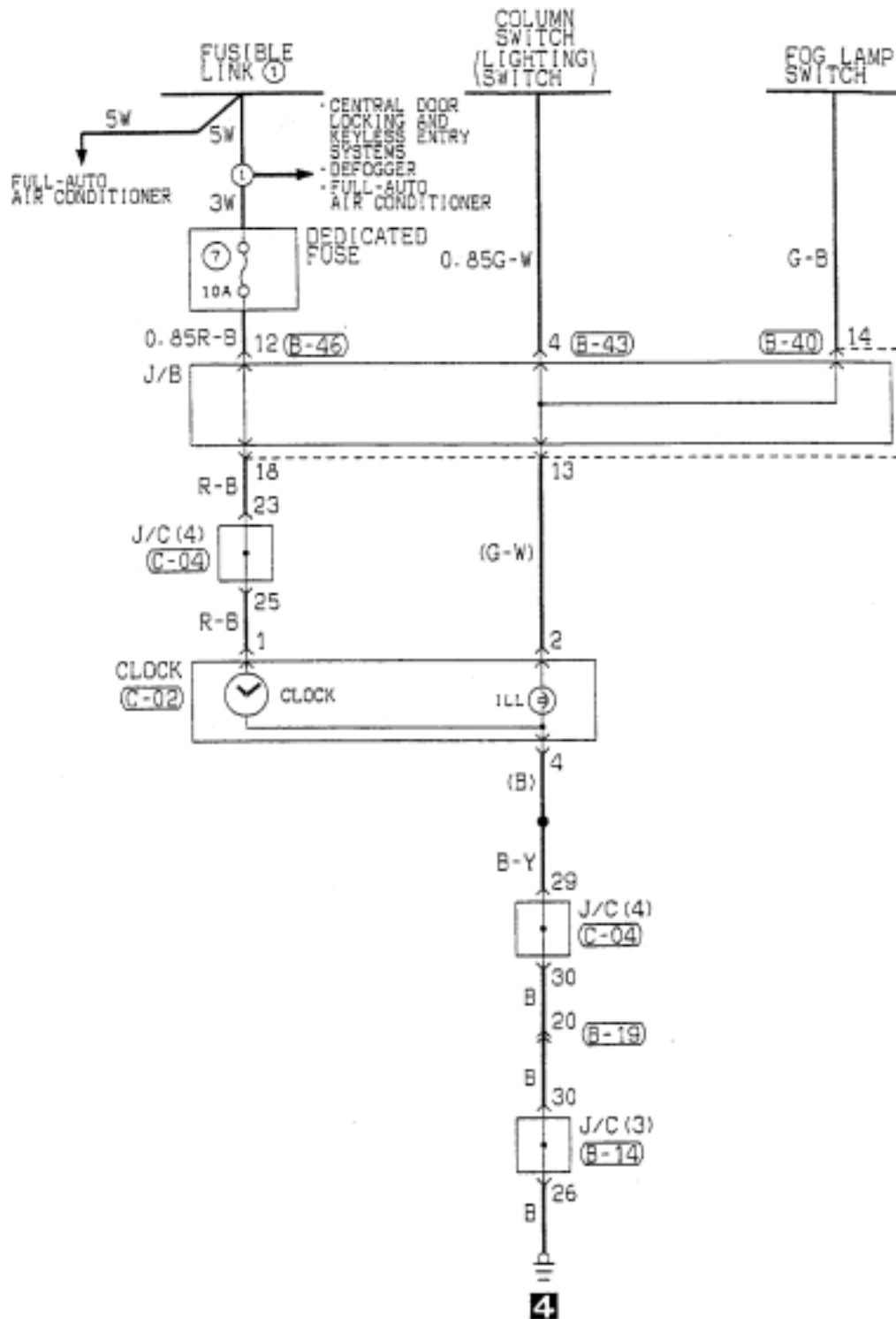

B-14

1	2	3	4	5	6	7	8	9	10	11
12	13	14	15	16	17	18	19	20	21	22
23	24	25	26	27	28	29	30	31	32	33

B-19

1	2	3	4	5	6	7	8	9	10
11	12	13	14	15	16	17	18	19	20
21	22	23	24	25	26	27	28	29	30

B-40

1	2	3	4	5	6	7	8	9	10
11	12	13	14	15	16	17	18	19	20
21	22	23	24	25	26	27	28	29	30

B-43

1	2	3	4	5	6	7	8	9	10
11	12	13	14	15	16	17	18	19	20
21	22	23	24	25	26	27	28	29	30

B-46

1	2	3	4	5	6	7	8	9	10
11	12	13	14	15	16	17	18	19	20
21	22	23	24	25	26	27	28	29	30

C-02

1	2	3	4
---	---	---	---

C-04

1	2	3	4	5	6	7	8	9	10	11
12	13	14	15	16	17	18	19	20	21	22
23	24	25	26	27	28	29	30	31	32	33

Wire colour code

B : Black LG : Light green G : Green L : Blue W : White Y : Yellow SB : Sky blue  
 BR : Brown O : Orange GR : Gray R : Red P : Pink V : Violet

CIGARETTE LIGHTER AND ASHTRAY ILLUMINATION LAMP

1

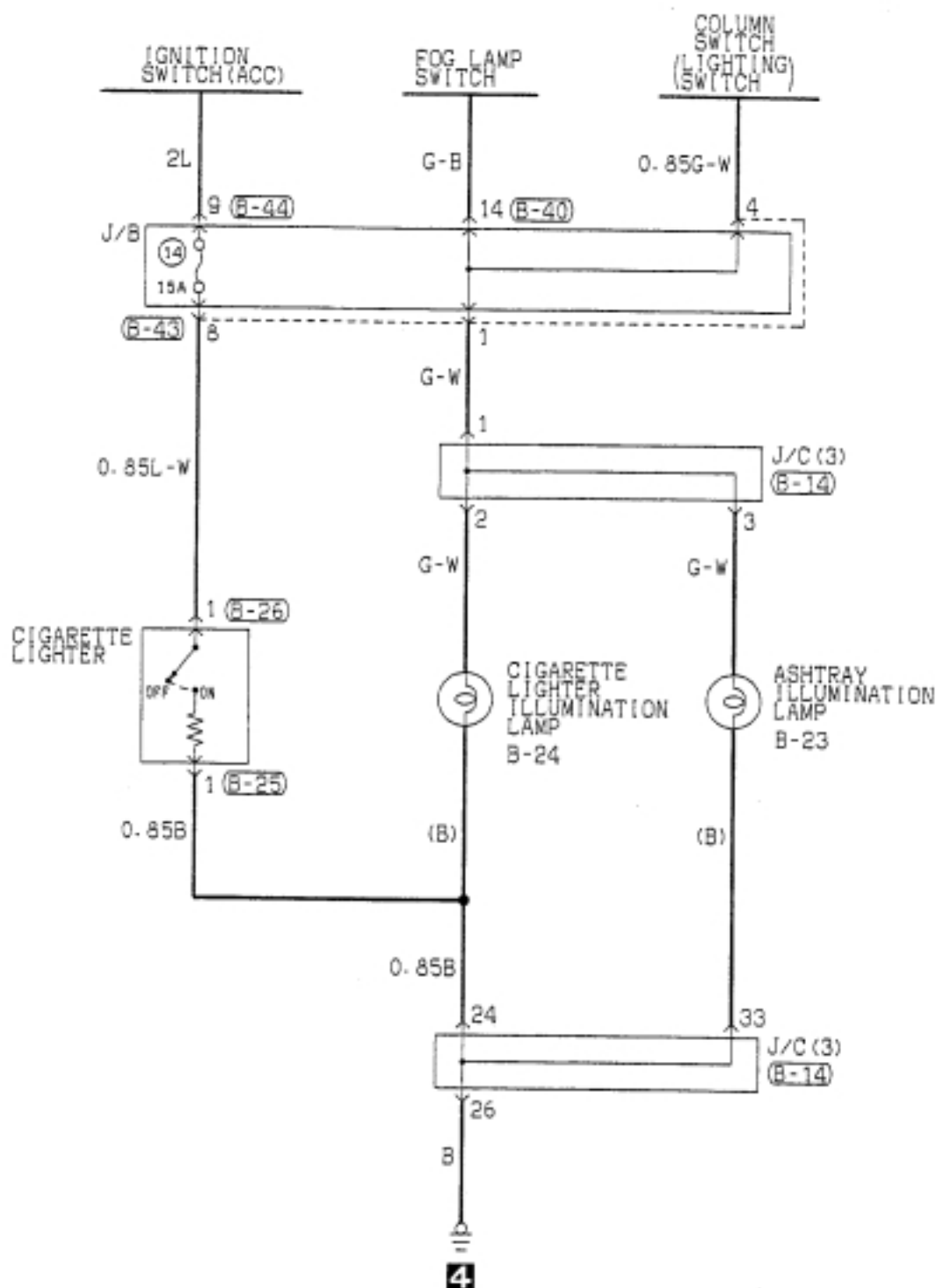

(B-14)

1	2	3	4	5	6	7	8	9	10	11
12	13	14	15	16	17	18	19	20	21	22
23	24	25	26	27	28	29	30	31	32	33

(B-25)

1
---

(B-26)

1
---

(B-40)

1	2	3	4	5	6	7	8	9	10	11
12	13	14	15	16	17	18	19	20	21	22

(B-43)

1	2	3	4	5	6	7	8	9	10	11
12	13	14	15	16	17	18	19	20	21	22

(B-44)

1	2	3	4
5	6	7	8
9	10	11	12

Wire colour code  
 B : Black LG : Light green G : Green L : Blue W : White Y : Yellow SB : Sky blue  
 BR : Brown O : Orange GR : Gray R : Red P : Pink V : Violet

LIGHTING MONITOR BUZZER

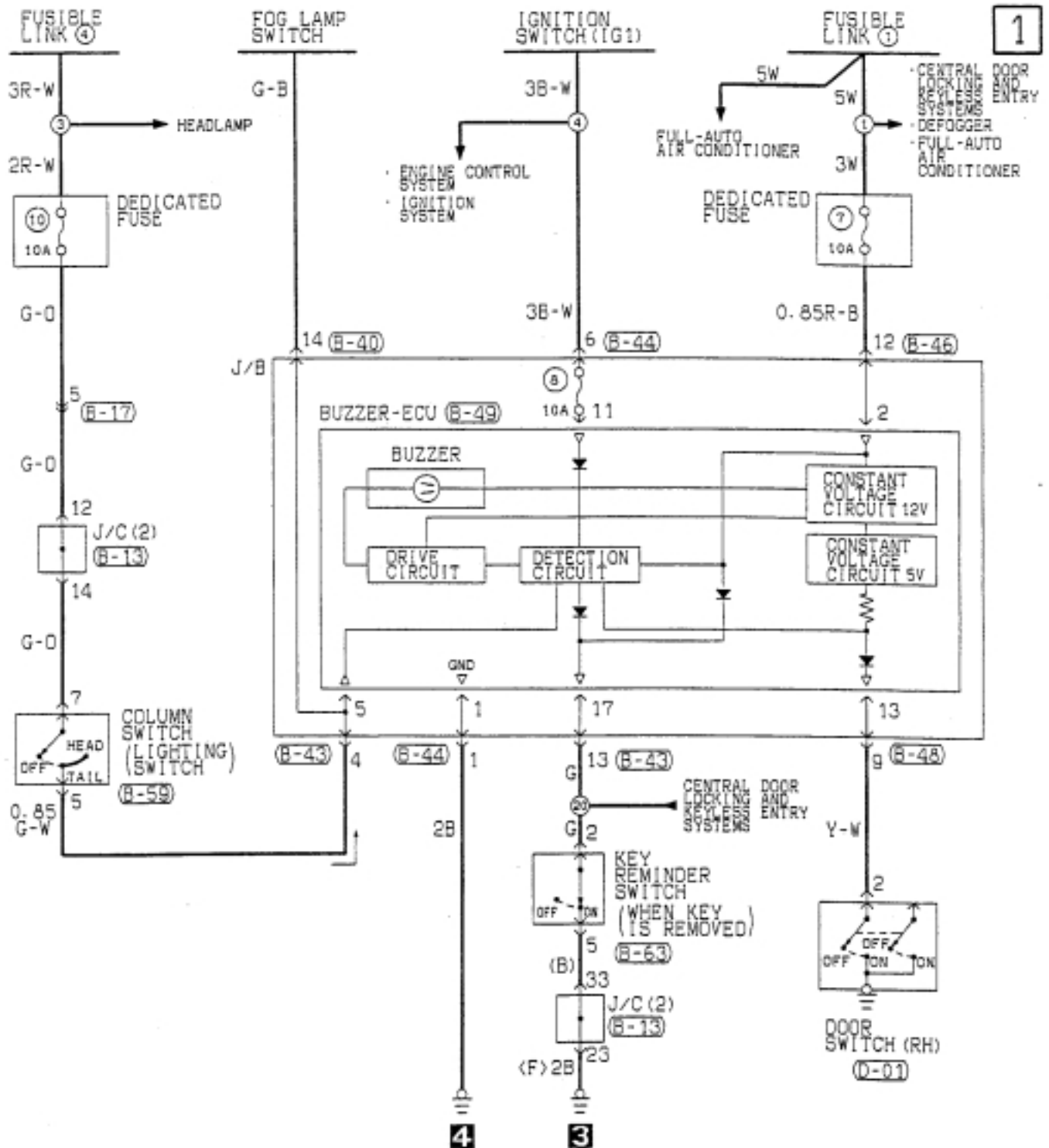

**B-13**

1	2	3	4	5	6	7	8	9	10	11
12	13	14	15	16	17	18	19	20	21	22
23	24	25	26	27	28	29	30	31	32	33

**B-17**

1	2	3	4	M	6	7	8
9	10	11	12	13	14	15	16

**B-40**

1	2	3	4	5	M	7	8	9	10
11	12	13	14	15	16	17	18	19	20
21	22	23	24	25	26	27	28	29	30

**B-43**

1	2	3	4	M	6	7	8	9
10	11	12	13	14	15	16	17	18
19	20	21	22	23	24	25	26	27

**B-44**

1	2	3	4
5	6	7	8
9	10	11	12

**B-46**

1	2	3	4	M	6	7	8
9	10	11	12	13	14	15	16
17	18	19	20	21	22	23	24

**B-48**

1	2	3	4	M	6	7	8	9
10	11	12	13	14	15	16	17	18
19	20	21	22	23	24	25	26	27

**B-49**

1	2	3	4	5	6	7	8	9	10	M	12	13	14	15	16	17	18	19	20
---	---	---	---	---	---	---	---	---	----	---	----	----	----	----	----	----	----	----	----

**B-59**

1	2	M	3	4
5	6	7	8	9
10	11	12	13	14

**B-63**

1	2	M	3	4
5	6	7	8	9
10	11	12	13	14

**D-01**

M	
1	2

KEY REMINDER BUZZER

1

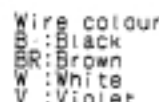
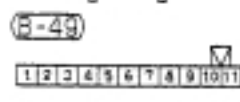
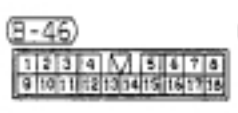
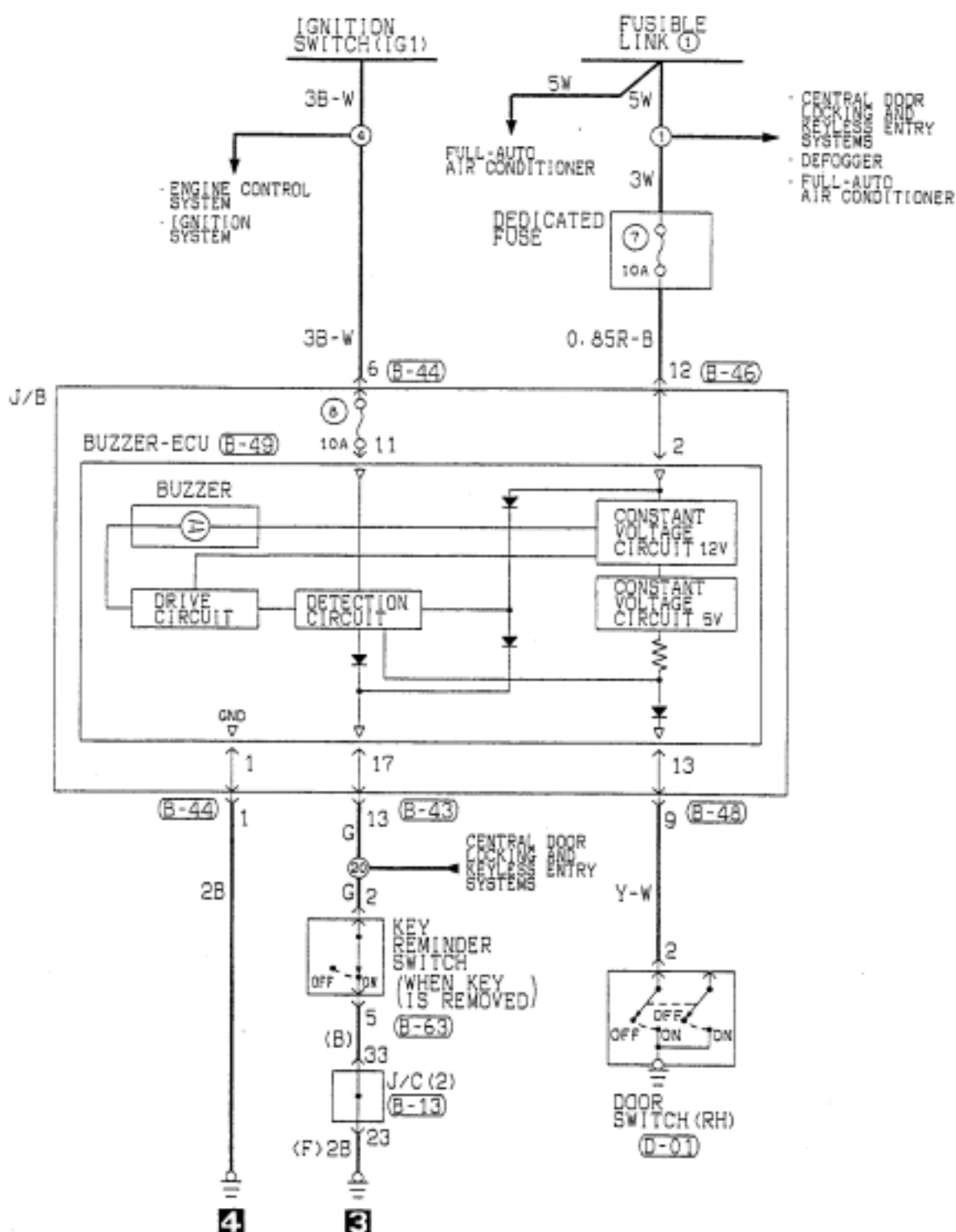

Wire colour code  
 BB: Black LG: Light green G: Green  
 BR: Brown O: Orange GR: Gray  
 W: White SB: Sky blue PR: Pink  
 V: Violet Y-CRL: Blue  
 Y: Yellow

SUNROOF

1

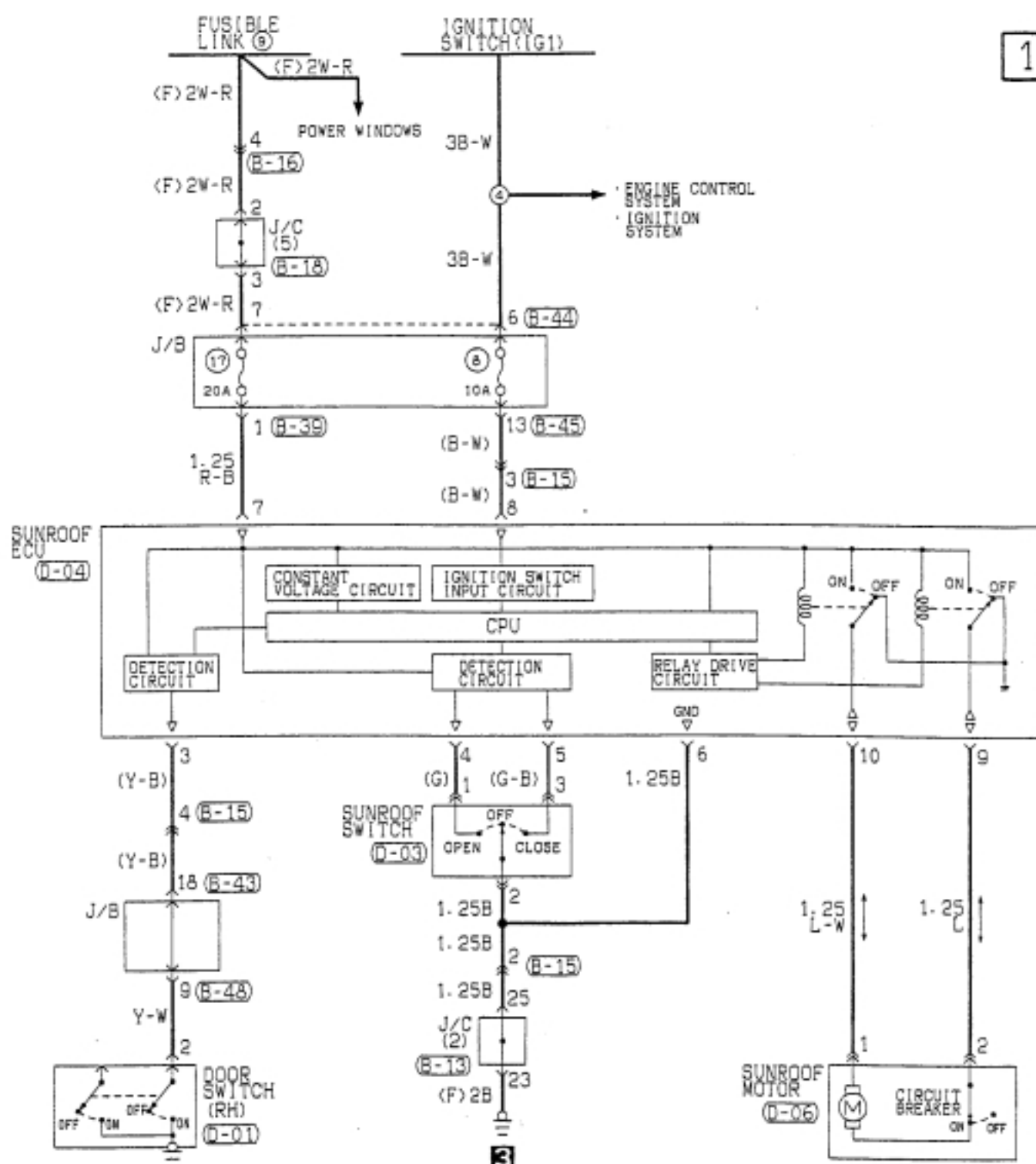

3

<b>B-13</b> 1 2 3 4 5 6 7 8 9 10 11 12 13 14 15 16 17 18 19 20 21 22 23 24 25 26 27 28 29 30 31 32 33	<b>B-15</b> 1 2 3 4 5 6 7 8	<b>B-16</b> 1 2 3 4	<b>B-18</b> 1 2 3 4	<b>B-39</b> M 1 2 3 4	<b>B-43</b> 1 2 3 4 5 6 7 8 9 10 11 12 13 14 15 16 17 18 19 20	<b>B-44</b> 1 2 3 4 5 6 7 8 9 10	<b>B-45</b> 1 2 3 4 5 6 7 8 9 10 11 12 13 14 15 16 17 18
<b>B-48</b> 1 2 3 4 5 6 7 8 9 10 11 12 13 14 15 16 17 18 19	<b>D-01</b> M 1 2	<b>D-03</b> L 1 2 3	<b>D-04</b> A 1 2 3 4 5 6 7 8 9 10	<b>D-06</b> M 1 2			



ANTI-SKID BRAKING SYSTEM (ABS)

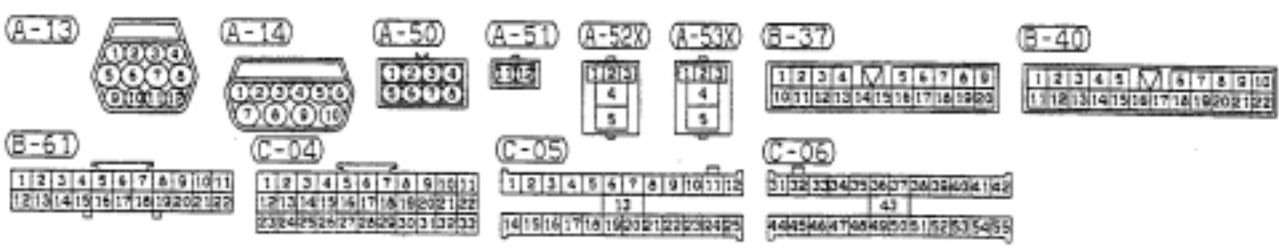
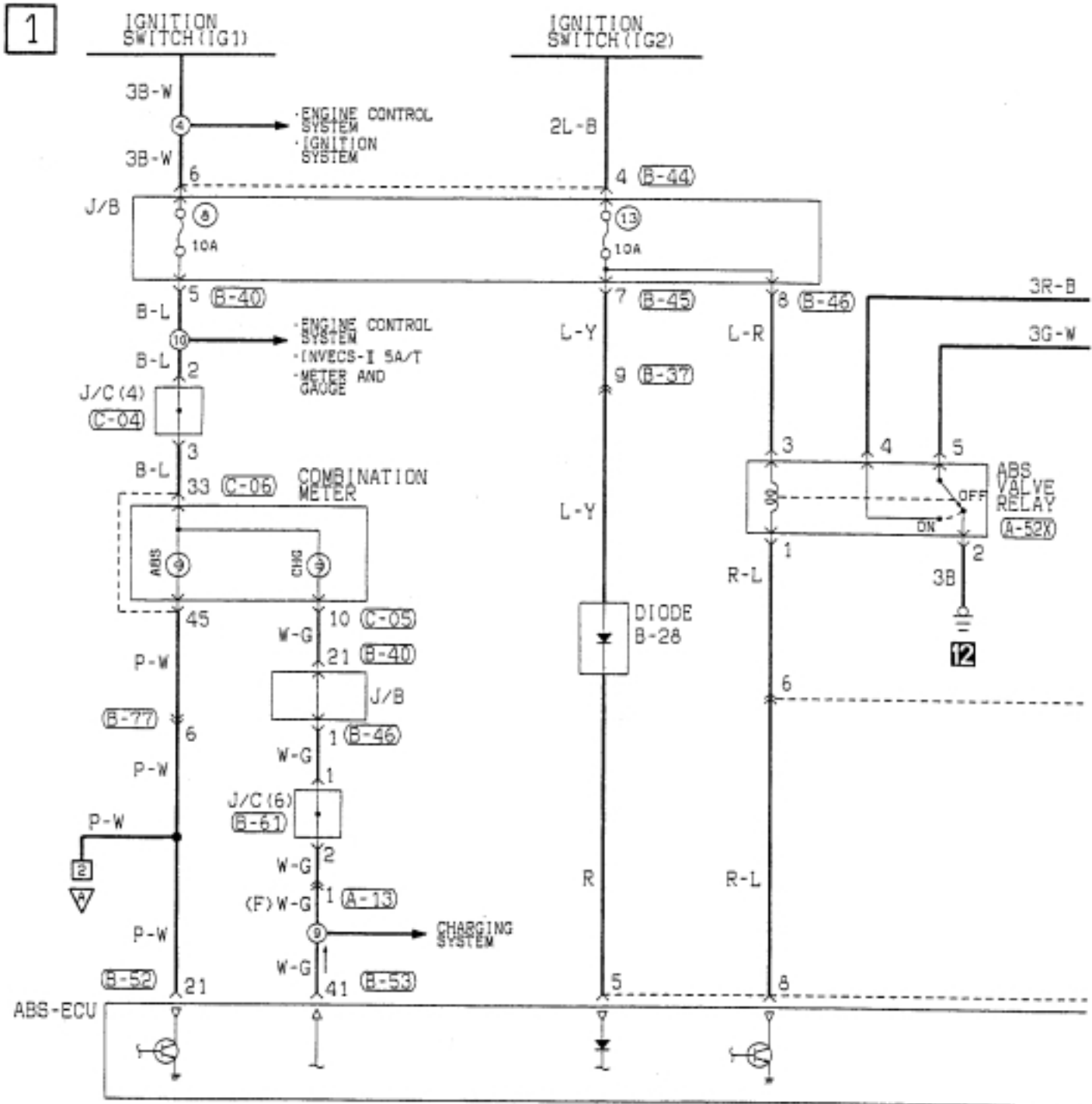

2

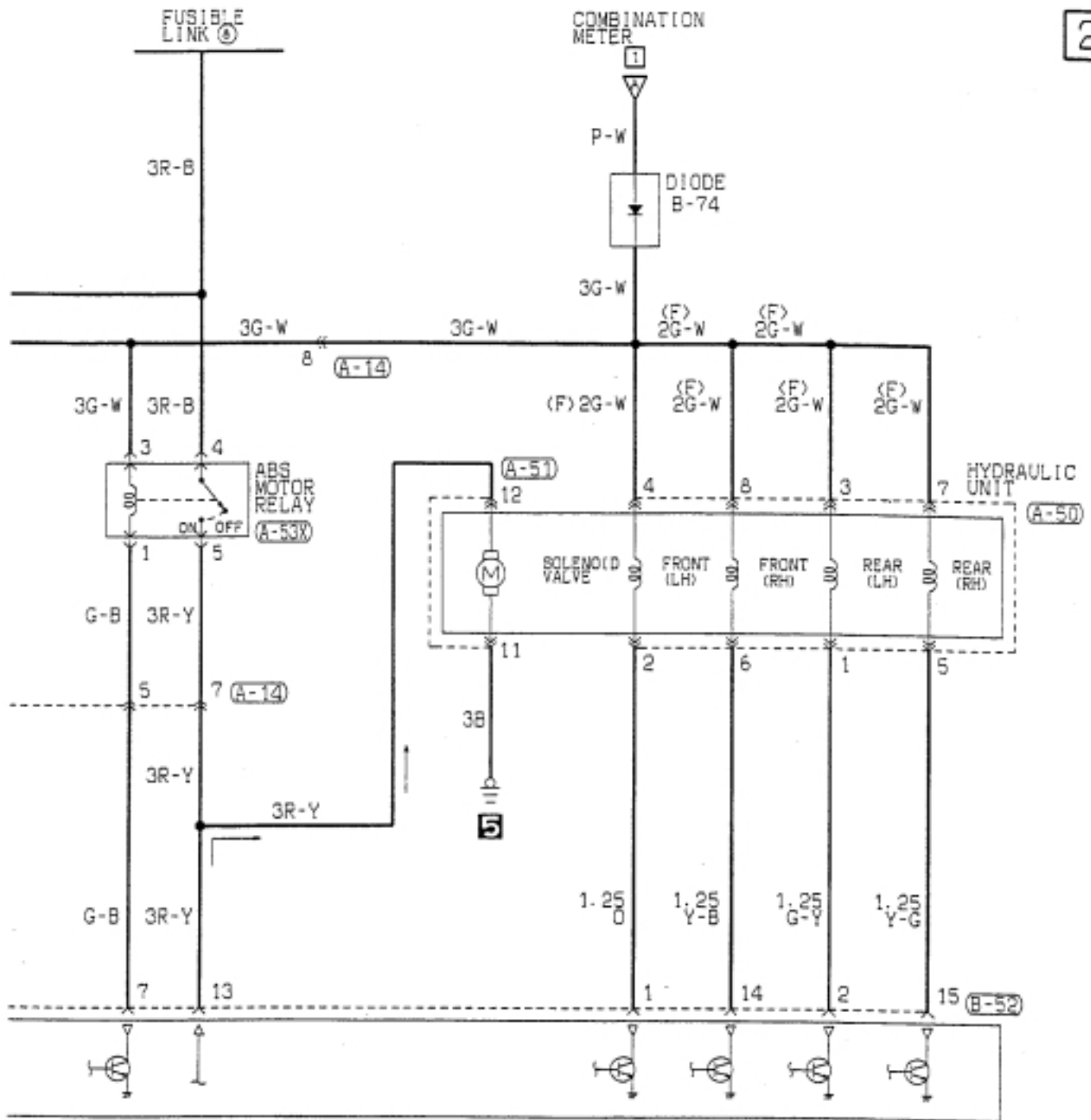

(B-44)

1	2	3	4
5	6	7	8

(B-45)

1	2	3	4	M	5	6	7	8
9	10	11	12	13	14	15	16	17

(B-46)

1	2	3	4	M	5	6	7	8
9	10	11	12	13	14	15	16	17

(B-52)

1	2	3	4	5	6	7	8	9	10	11	12	13
14	15	16	17	18	19	20	21	22	23	24	25	26

(B-53)

3	10	23	30	40	50	56	61	68
78	84	102	104	105	106	107	108	109

(B-77)

1	2	3	4	M	5	6	7	8
9	10	11	12	13	14	15	16	17

Wire colour code

BB:Black LG:Light green G:Green L:Blue W:White Y:Yellow SB:Sky blue  
 BR:Brown O:Orange GR:Gray R:Red P:Pink V:Violet

ANTI-SKID BRAKING SYSTEM (ABS) (CONTINUED)

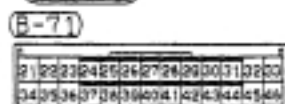
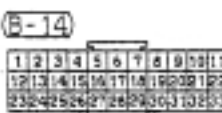
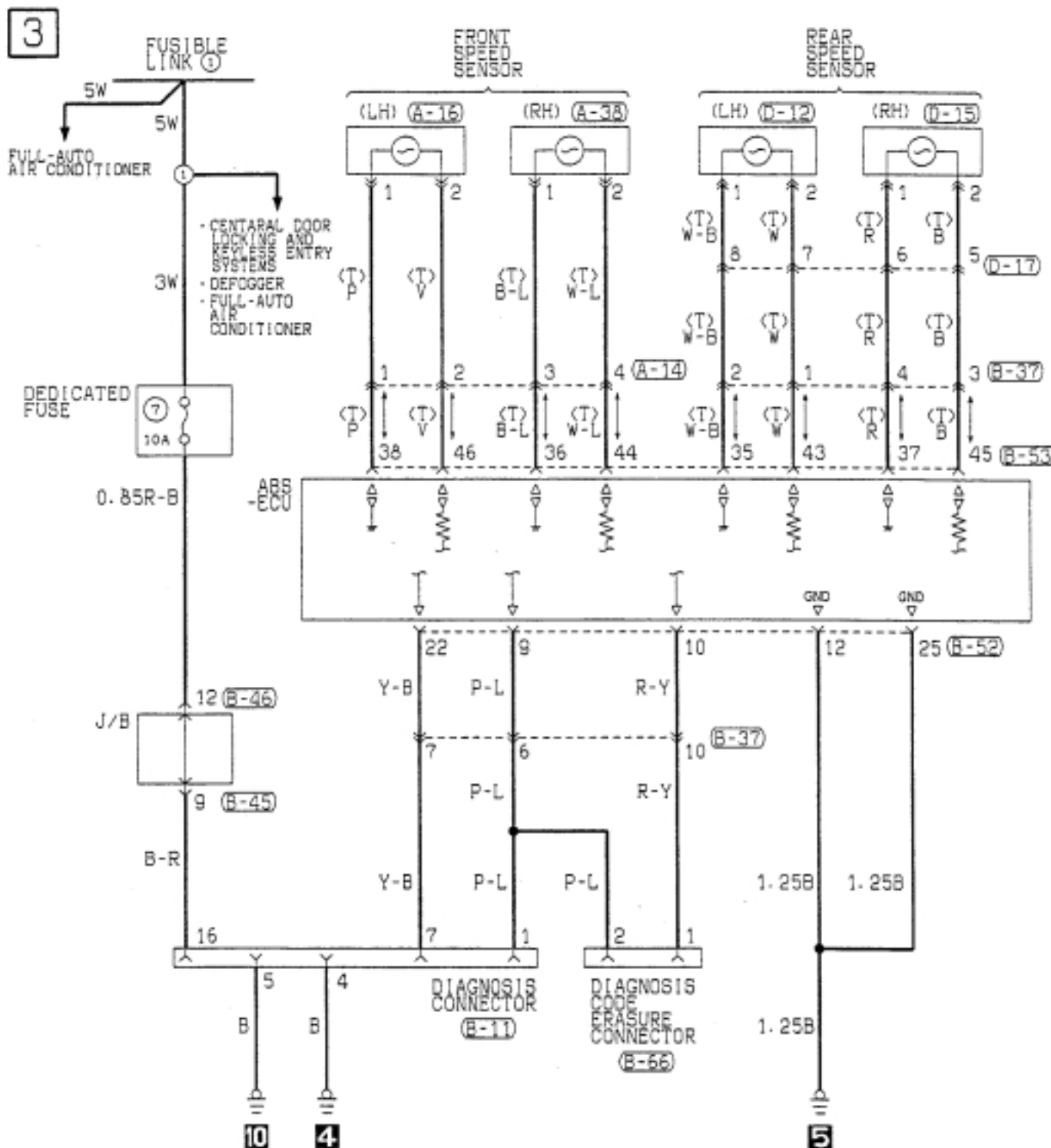

4

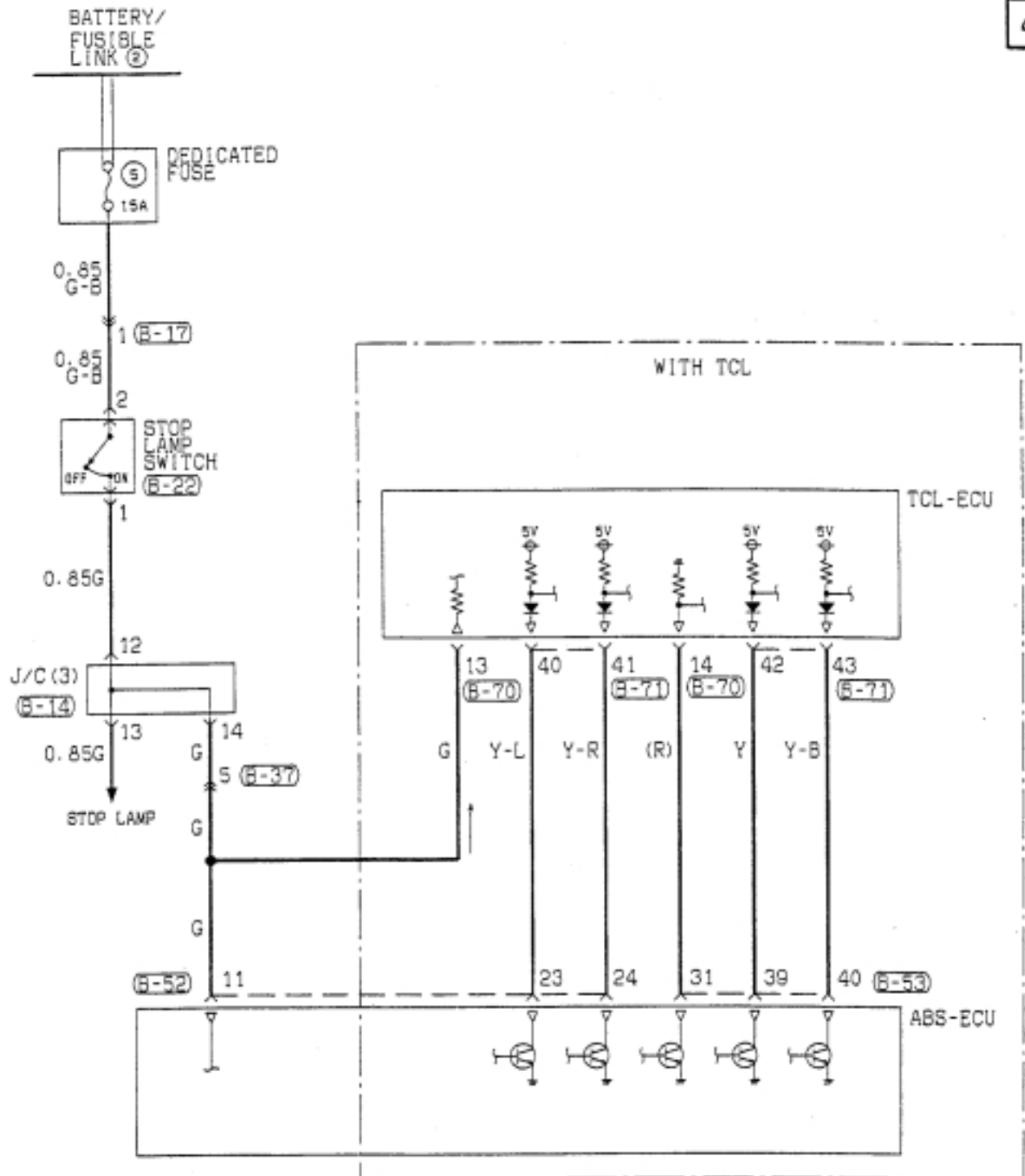

B-45

1	2	3	4	M	5	6	7	8	
9	10	11	12	13	14	15	16	17	18

B-46

1	2	3	4	M	5	6	7	8	
9	10	11	12	13	14	15	16	17	18

B-52

1	2	3	4	5	6	7	8	9	10	11	12	13
14	15	16	17	18	19	20	21	22	23	24	25	26

B-53

1	2	3	4	5	6	7	8
9	10	11	12	13	14	15	16

B-66

1
2

B-70

1	2	3	4	5	6	7	8
9	10	11	12	13	14	15	16

Wire colour code  
 BK:Black LG:Light green G:Green L:Blue W:White Y:Yellow SB:Sky blue  
 BR:Brown O:Orange GR:Gray R:Red P:Pink V:Violet

TRACTION CONTROL SYSTEM (TCL)

1

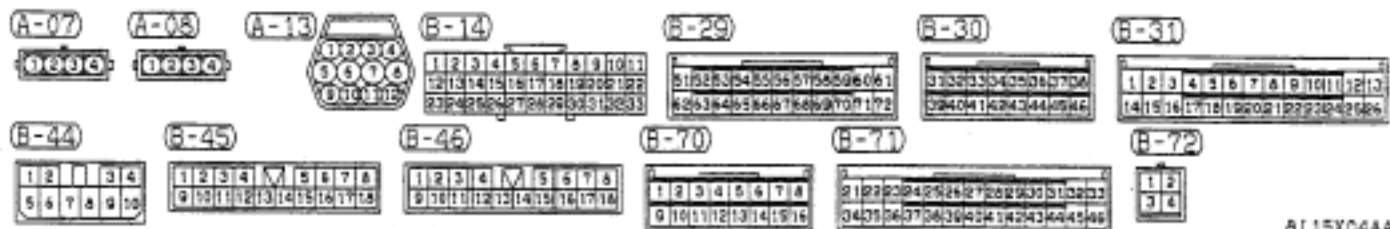
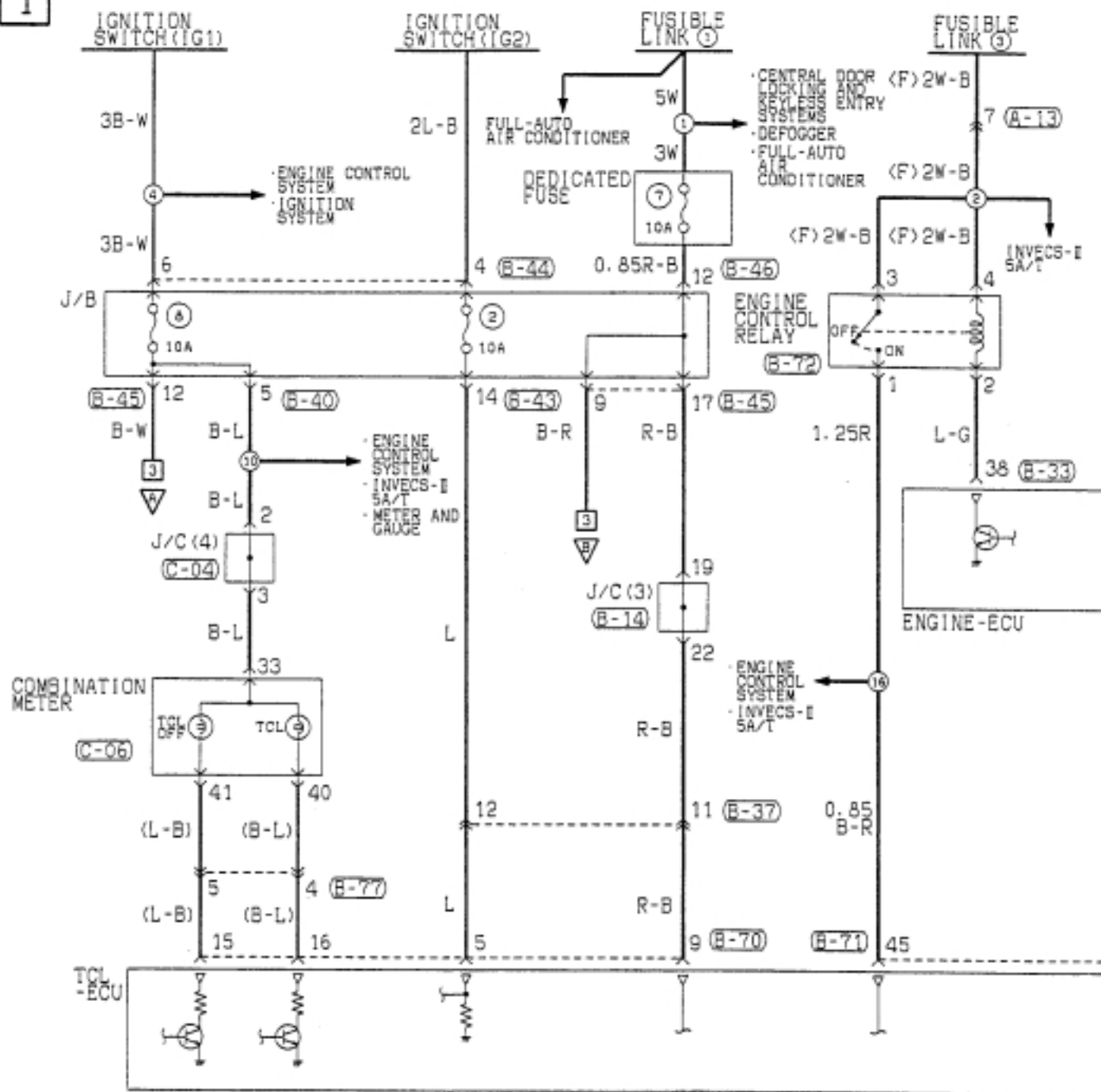

2

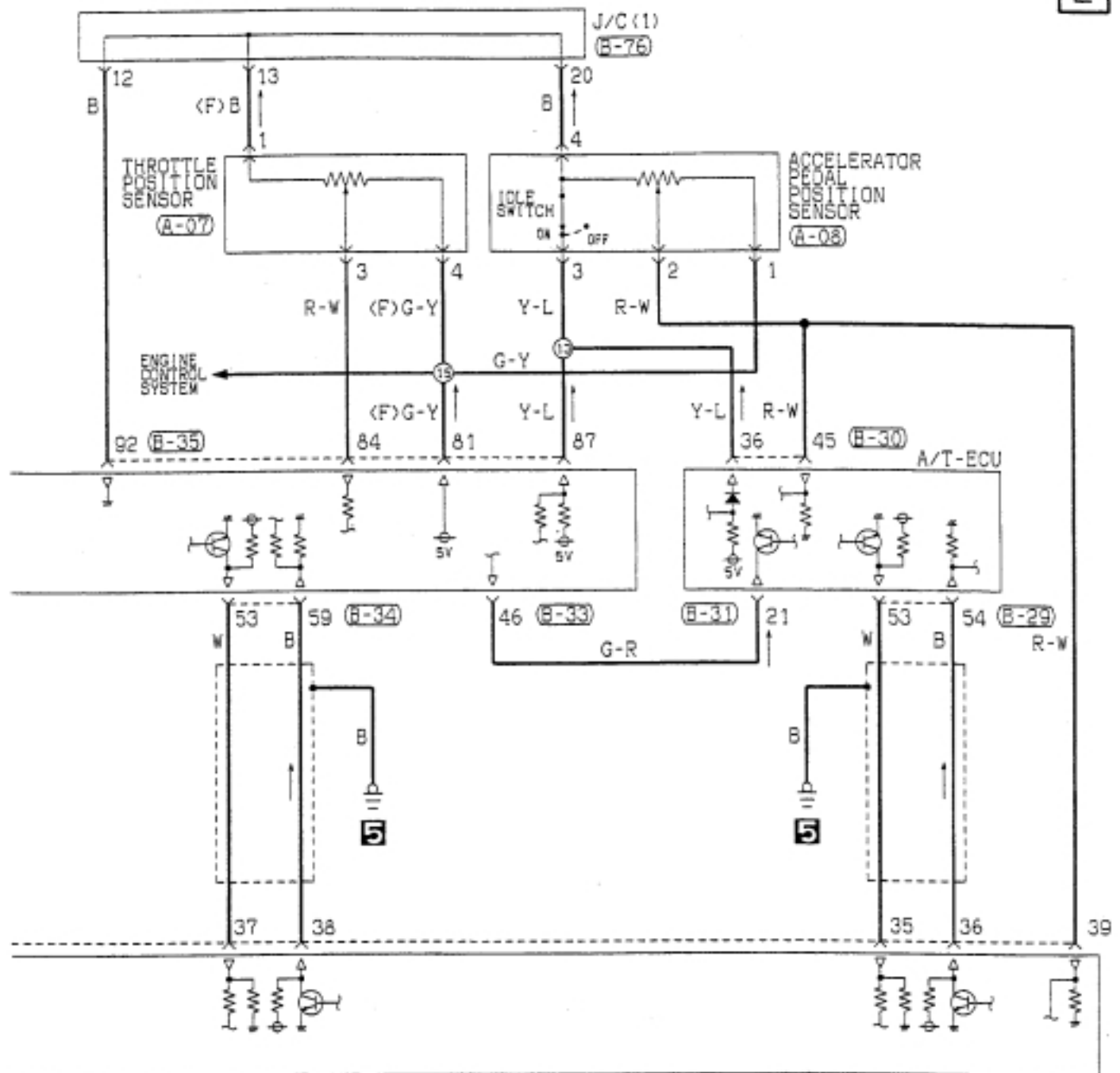

B-32

1	2	3	4	5	6	7	8	9	10
31	32	33	34	35	36	37	38	39	40
41	42	43	44	45	46	47	48	49	50

B-34

1	2	3	4	5	6	7	8	9	10
51	52	53	54	55	56	57	58	59	60
61	62	63	64	65	66	67	68	69	70

B-35

1	2	3	4	5	6	7	8	9	10
71	72	73	74	75	76	77	78	79	80
81	82	83	84	85	86	87	88	89	90

B-37

1	2	3	4	M	6	7	8	9	10
10	11	12	13	14	15	16	17	18	19
20	21	22	23	24	25	26	27	28	29

B-40

1	2	3	4	M	7	8	9	10	11
12	13	14	15	16	17	18	19	20	21
22	23	24	25	26	27	28	29	30	31

B-43

1	2	3	4	M	6	7	8	9	10
11	12	13	14	15	16	17	18	19	20
21	22	23	24	25	26	27	28	29	30

B-76

1	2	3	4	5	6	7	8	9	10
11	12	13	14	15	16	17	18	19	20
21	22	23	24	25	26	27	28	29	30

B-77

1	2	3	4	M	6	7	8	9	10
11	12	13	14	15	16	17	18	19	20
21	22	23	24	25	26	27	28	29	30

C-04

1	2	3	4	5	6	7	8	9	10
11	12	13	14	15	16	17	18	19	20
21	22	23	24	25	26	27	28	29	30

C-06

0	1	2	3	4	5	6	7	8	9	10	11	12	13	14	15	16	17	18	19	20
21	22	23	24	25	26	27	28	29	30	31	32	33	34	35	36	37	38	39	40	41
42	43	44	45	46	47	48	49	50	51	52	53	54	55	56	57	58	59	60	61	62

TRACTION CONTROL SYSTEM (TCL) (CONTINUED)

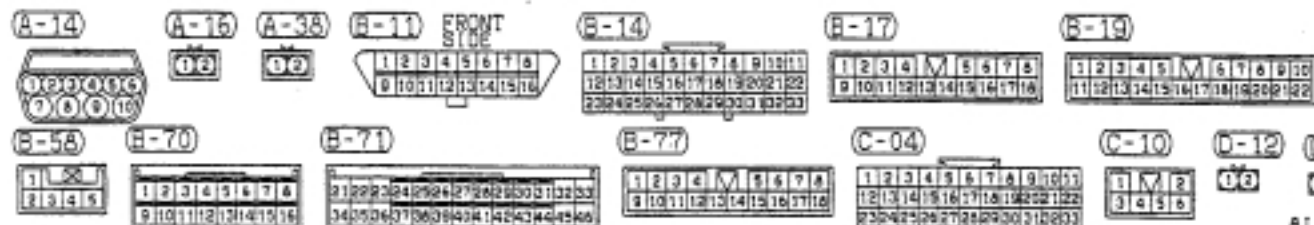
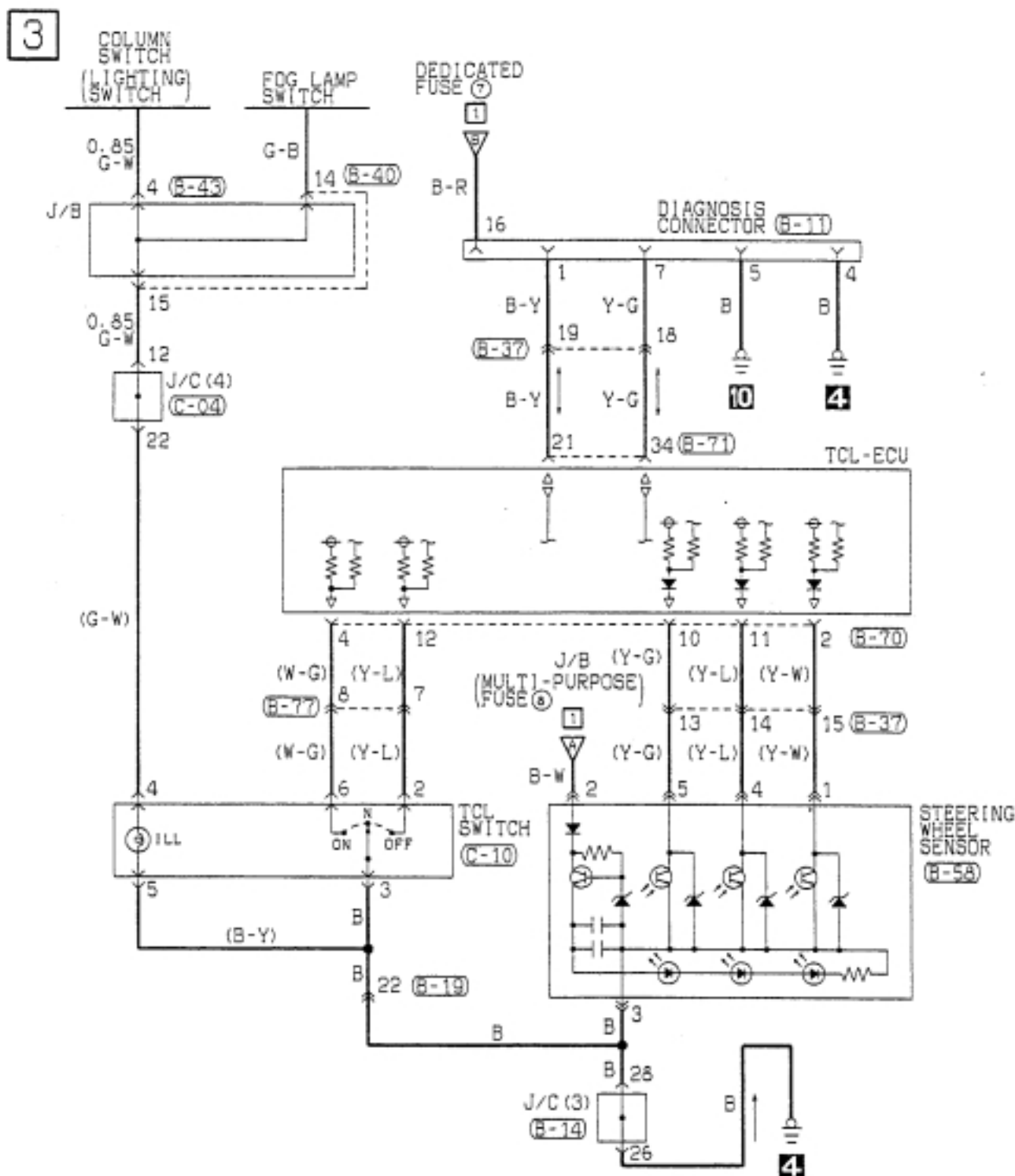

4

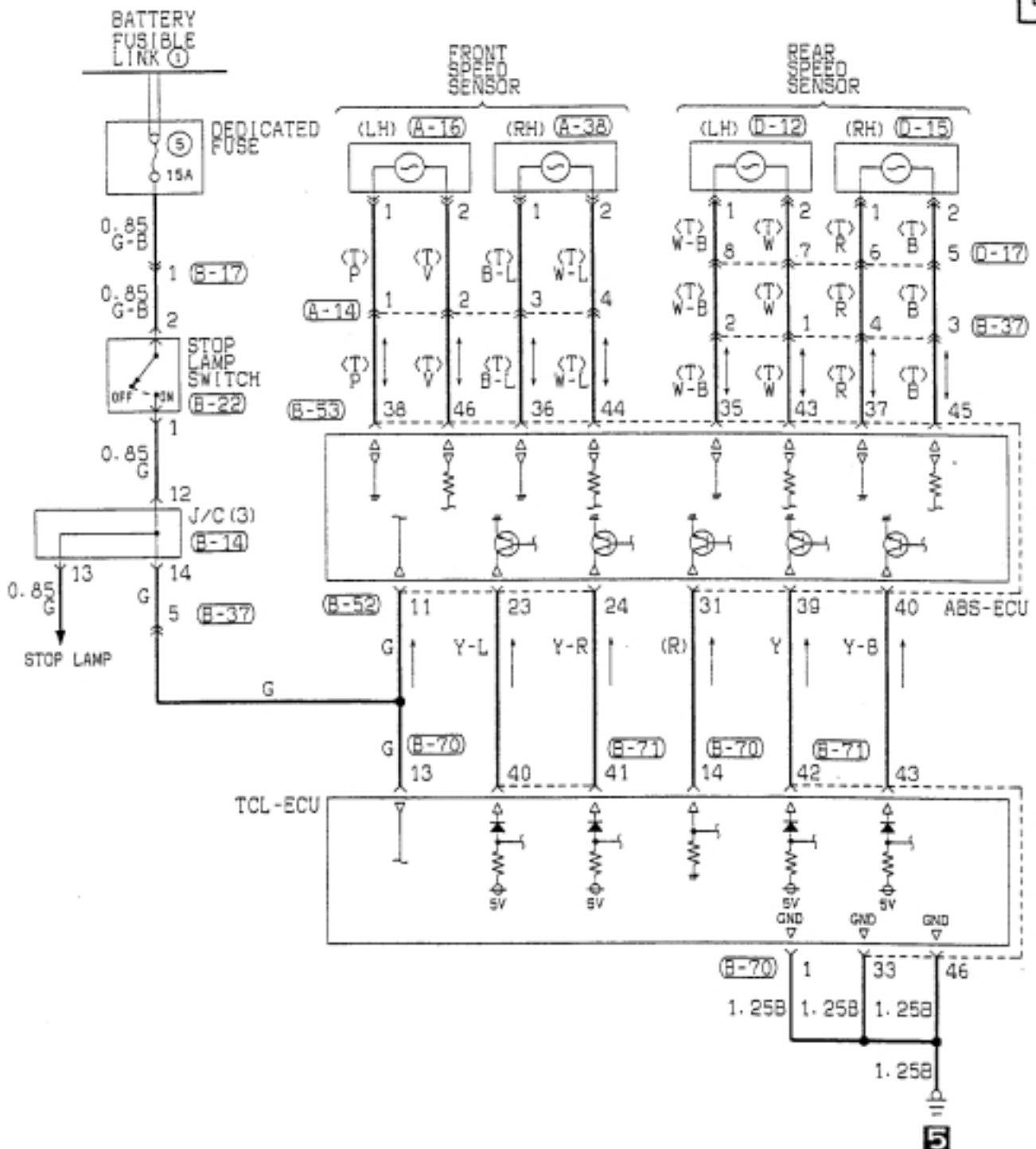

B-22

1
2

B-37

1	2	3	4	5	6	7	8	9		
10	11	12	13	14	15	16	17	18	19	20

B-40

1	2	3	4	5	6	7	8	9	10		
11	12	13	14	15	16	17	18	19	20	21	22

B-43

1	2	3	4	5	6	7	8	9		
10	11	12	13	14	15	16	17	18	19	20

B-52

1	2	3	4	5	6	7	8	9	10	11	12	13
14	15	16	17	18	19	20	21	22	23	24	25	26

B-53

1	2	3	4	5	6	7	8
9	10	11	12	13	14	15	16

D-17

1	2	3
4	5	6

Wire colour code

B : Black LG : Light green G : Green L : Blue W : White Y : Yellow SB : Sky blue  
 BR : Brown O : Orange GR : Gray R : Red P : Pink V : Violet



SUPPLEMENTAL RESTRAINT SYSTEM (SRS)

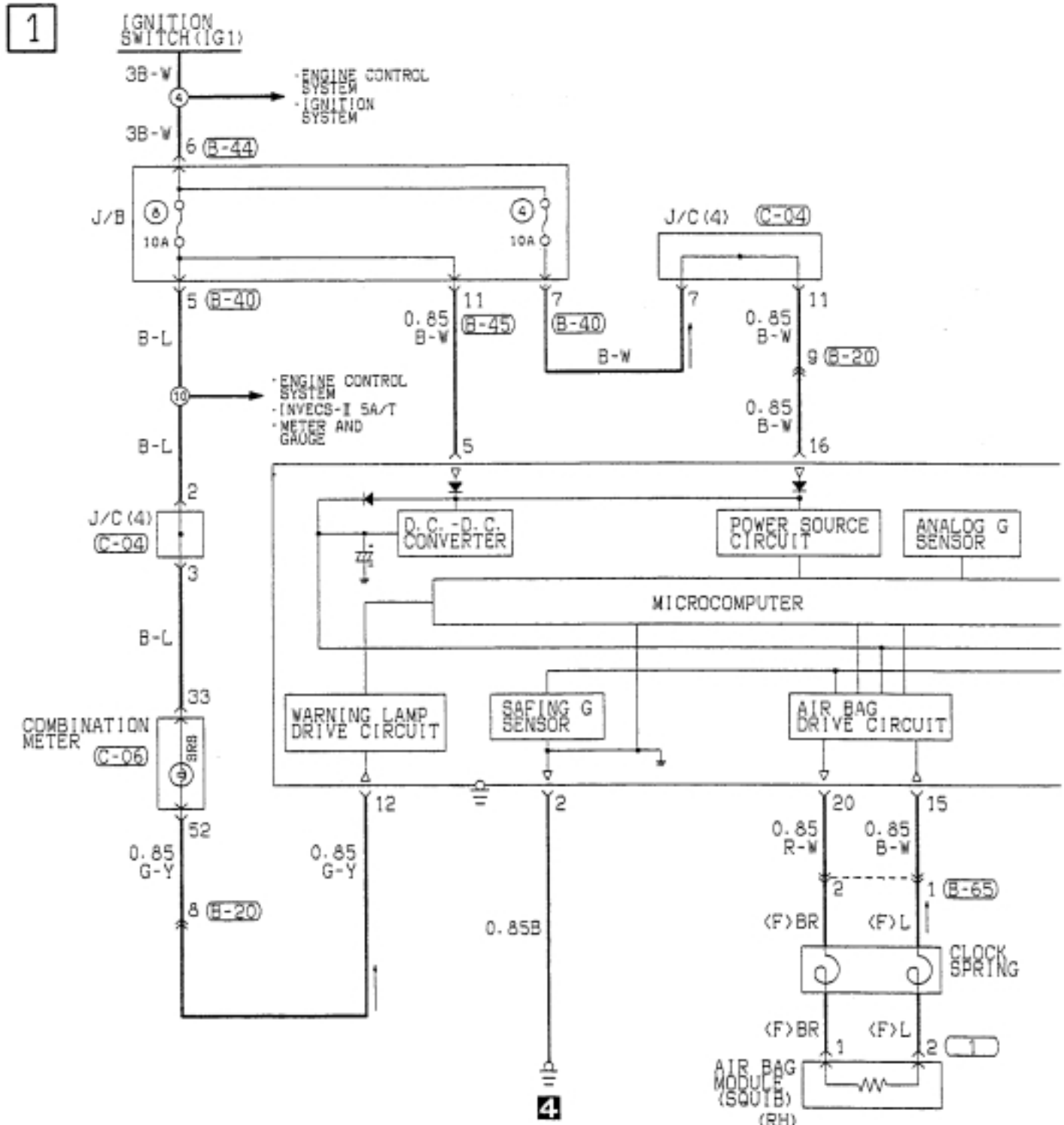

- (B-02) 

1	2	3	4	5	6	7	8
9	10	11	12	13	14	15	16
- (B-13) FRONT SIDE 

1	2	3	4	5	6	7	8
9	10	11	12	13	14	15	16
- (B-14) 

1	2	3	4	5	6	7	8	9	10	11
12	13	14	15	16	17	18	19	20	21	22
23	24	25	26	27	28	29	30	31	32	33
- (B-20) 

1	2	3	M	4	5	6	
7	8	9	10	11	12	13	14
- (B-27) 

1	2	3	4	5	6	7	8	9	10	11	12
13	14	15	16	17	18	19	20	21	22	23	24
- (B-40) 

1	2	3	4	5	M	6	7	8	9	10	
11	12	13	14	15	16	17	18	19	20	21	22

2

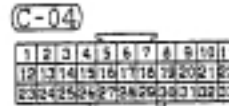
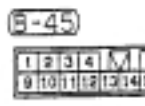
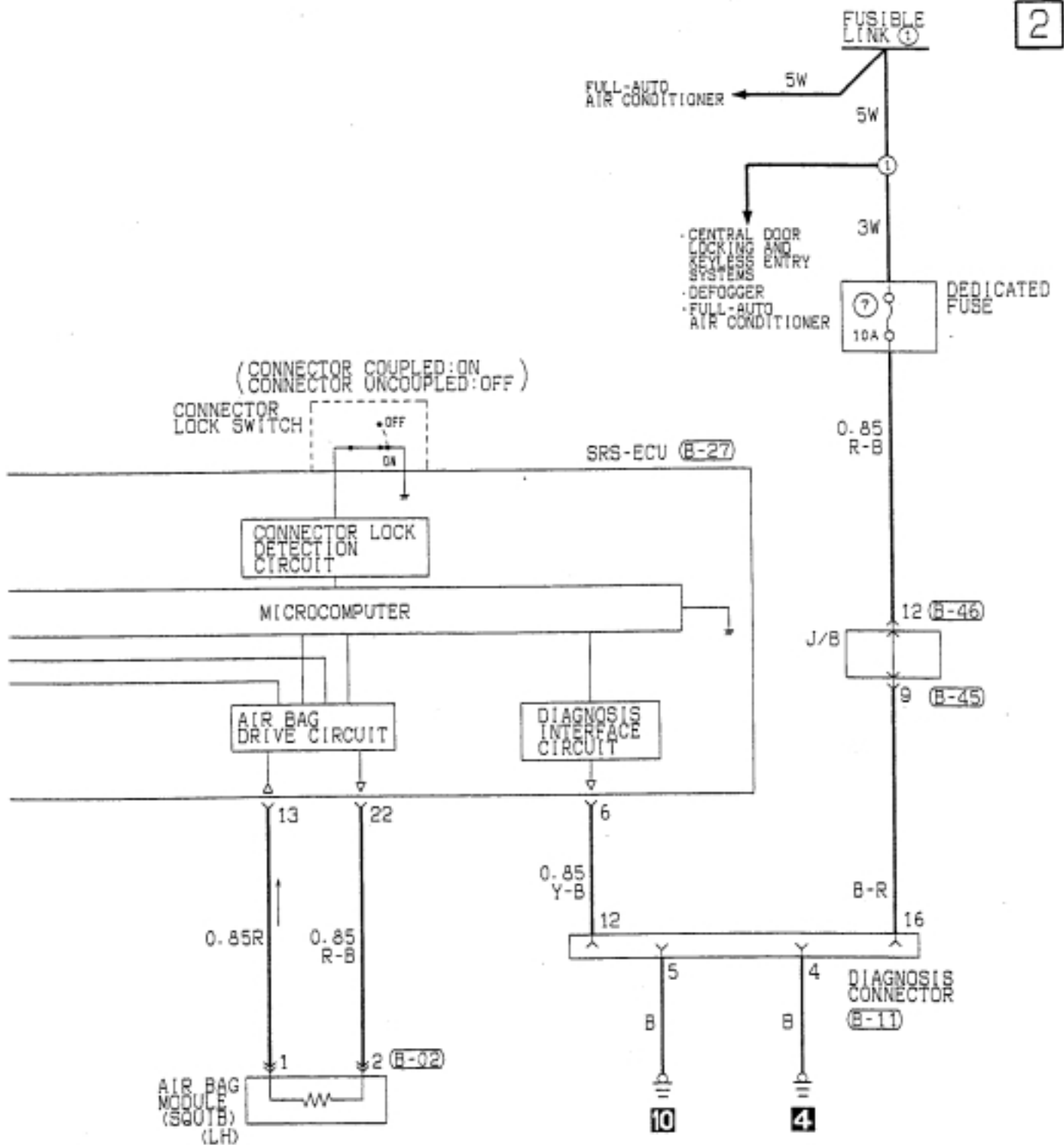

Wire colour code  
 B: Black LG: Light green G: Green L: Blue W: White Y: Yellow SB: Sky blue  
 BR: Brown O: Orange GR: Gray R: Red P: Pink V: Violet

---

NOTES

## INDEX (In order of connector No.)

	Connector No.	Parts name	Circuit diagram page	Wiring diagram page
A	A-01	Brake fluid level sensor	4-75	2-4
	A-02	Variable induction control servo	4-28, 37	2-4
	A-03	Variable induction control servo	4-28, 37	2-4
	A-04	Intake air temperature sensor	4-29, 36	2-4
	A-05	Atmospheric pressure sensor	4-28, 36	2-4
	A-06	Vehicle speed sensor	4-26, 34, 40, 48, 72	2-4
	A-07	Throttle position sensor	4-28, 36, 43, 51, 109	2-5
	A-08	Accelerator pedal position sensor	4-36, 51, 109	2-5
	A-09	Idle speed control servo	4-28, 36	2-5
	A-10	Windshield wiper motor	4-89	2-5
	A-11	Dual pressure switch	4-86	2-5
	A-12	Control wiring harness and battery cable combination	4-19	2-5
	A-13	Control wiring harness and front wiring harness combination	4-22, 24, 27, 32, 35, 39, 44, 52, 74, 75, 83, 86, 104, 108	2-5
	A-14	Control wiring harness and front wiring harness combination <ABS>	4-104, 105, 106, 111	2-5
	A-15	Side turn signal lamp (LH)	4-67	2-5
	A-16	Front speed sensor (LH) <ABS>	4-106, 111	2-5
	A-17	Oil control valve (right bank side)	4-28, 36	2-5
	A-18	Control wiring harness and injector wiring harness combination	4-22, 28, 29, 36, 37	2-5
	A-19	Detonation sensor	4-30, 38	2-5
	A-20	Horn (LO)	4-71	2-5
	A-21	Horn (LO)	4-71	2-5
	A-22	Windshield washer motor	4-89	2-5
	A-23	Rear washer motor	4-90	2-5
	A-24	Radiator fan motor	4-39, 83	2-5
	A-25	A/T control solenoid valve assembly	4-45, 53	2-5
	A-26	Engine coolant temperature gauge unit	4-73	2-5
	A-27	Back-up lamp switch <M/T>	4-69	2-5
	A-28	Ignition coil C	4-21, 25, 33	2-5
	A-29	Ignition coil A	4-21, 25, 33	2-4

	Connector No.	Parts name	Circuit diagram page	Wiring diagram page
A	A-30	Ignition coil B	4-21, 25, 33	2-4
	A-31	Oil pressure switch	4-74	2-4
	A-32	A/C compressor assembly	4-86	2-4
	A-33	Power steering oil pressure switch	4-27, 35	2-4
	A-34	Condenser fan motor	4-39, 83	2-4
	A-35	Outside thermo sensor <A/C>	4-85	2-4
	A-36	Horn (HI)	4-71	2-4
	A-37	Horn (HI)	4-71	2-4
	A-38	Front speed sensor (RH) <ABS>	4-106, 111	2-4
	A-39	Side turn signal lamp (RH)	4-67	2-4
	A-40	Oil control valve (left bank side)	4-28, 36	2-6
	A-41	Injector No.1	4-28, 36	2-6
	A-42	Injector No.3	4-29, 37	2-6
	A-43	Injector No.5	4-29, 37	2-6
	A-44	Vacuum solenoid valve <TCL>	4-38	2-7
	A-45	Capacitor	4-21, 25, 33	2-7
	A-46	Ventilation solenoid valve <TCL>	4-38	2-7
	A-47	Capacitor	4-20, 25, 33	2-7
	A-48	Engine speed detection connector	4-20, 25, 33, 72	2-7
	A-50	Hydraulic unit <ABS>	4-105	2-7
	A-51	Hydraulic unit <ABS>	4-105	2-7
	A-52X	ABS valve relay	4-13, 104	2-7
	A-53X	ABS motor relay	4-13, 105	2-7
	A-54X	Headlamp relay	4-13, 18, 56, 58	2-7
	A-55X	A/C compressor relay	4-13, 86	2-7
	A-56X	Condenser fan relay	4-13, 39, 83	2-7
	A-57X	Radiator fan relay	4-13, 39, 83	2-7
	A-58X	Horn relay	4-13, 71	2-7
	A-59X	Alternator relay	4-13, 22	2-7
	A-60X	Power window relay	4-13, 76	2-7
	A-61X	Headlamp relay <vehicles with discharge type headlamp>	4-13, 18, 58	2-7

	Connector No.	Parts name	Circuit diagram page	Wiring diagram page
A	A-62X	No connection	4-13	2-7
	A-63X	No connection	4-13	2-7
	A-64X	No connection	4-13	2-7
	A-65	Ignition failure sensor	4-20, 25, 33	2-7
	A-66	Headlamp (LH) <discharge type>	4-58, 61	2-7
	A-67	Headlamp (LH) <except discharge type>	4-56	2-7
	A-68	Position lamp (LH) <vehicles without discharge type headlamp>	4-60	2-7
	A-69	Headlamp (LH)	4-56, 58	2-7
	A-70	Front turn signal lamp (LH)	4-67	2-7
	A-71	Fog lamp (LH)	4-62	2-7
	A-72	Output shaft speed sensor <A/T>	4-46, 54	2-7
	A-73	Input shaft speed sensor <A/T>	4-46, 54	2-7
	A-74	Inhibitor switch <A/T>	4-19, 24, 32, 40, 48, 70	2-7
	A-75	Engine coolant temperature sensor	4-29, 37	2-7
	A-76	Starter	4-19	2-6
	A-77	Starter	4-19	2-6
	A-78	Injector No.6	4-29, 37	2-6
	A-79	Injector No.4	4-29, 37	2-6
	A-80	Front wiring harness and oil pressure wiring harness combination	4-74	2-6
	A-81	Injector No.2	4-28, 36	2-6
	A-82	Alternator	4-22	2-6
	A-83	Alternator	4-22	2-6
	A-84	Fog lamp (RH)	4-62	2-6
	A-85	Front turn signal lamp (RH)	4-67	2-6
	A-86	Headlamp (RH)	4-56, 58	2-6
	A-87	Position lamp (RH) <vehicles without discharge type headlamp>	4-60	2-6
	A-88	Headlamp (RH) <except discharge type>	4-56	2-6
	A-89	Headlamp (RH) <discharge type>	4-58, 61	2-6
	A-90	Camshaft position sensor	4-30, 38	2-6
	A-91	Crank angle sensor	4-30, 38, 44, 52	2-6

	Connector No.	Parts name	Circuit diagram page	Wiring diagram page
B	B-01	Outside/inside air selection damper control motor <A/C>	4-84	2-8
	B-02	Air bag module (LH)	4-113	2-8
	B-03	Power transistor <A/C>	4-82	2-8
	B-04	Air thermo sensor <A/C>	4-84	2-8
	B-05	Photo sensor <A/C>	4-85	2-8
	B-06	Air mixing damper control motor and potentiometer <A/C>	4-84	2-8
	B-07	Heater water temperature sensor <A/C>	4-84	2-8
	B-08	A/C-ECU	4-82, 84, 85, 92	2-8
	B-09	A/C-ECU	4-82, 84, 85, 92	2-8
	B-10	Mode selection damper control motor and potentiometer <A/C>	4-84	2-8
	B-11	Diagnosis connector	4-26, 34, 46, 54, 80, 85, 106, 110, 113	2-8
	B-12	Door lock-ECU	4-78	2-9
	B-13	J/C (2)	4-6, 57, 59, 60, 61, 62, 65, 66, 71, 79, 88, 90, 95, 101, 102, 103	2-9
	B-14	J/C (3)	4-7, 41, 42, 49, 50, 62, 63, 67, 68, 73, 78, 85, 92, 94, 96, 98, 99, 100, 107, 108, 110, 111	2-9
	B-15	Body wiring harness and roof wiring harness combination	4-64, 65, 68, 79, 103	2-9
	B-16	Front wiring harness and body wiring harness combination	4-14, 15, 103	2-9
	B-17	Front wiring harness and body wiring harness combination	4-41, 49, 56, 57, 58, 59, 60, 61, 62, 68, 71, 76, 88, 89, 90, 101, 107, 111	2-9
	B-18	J/C (5)	4-8, 14, 85, 103	2-9
	B-19	Body wiring harness and instrument panel wiring harness combination	4-42, 50, 57, 59, 62, 66, 67, 72, 73, 74, 75, 89, 92, 94, 97, 98, 99	2-9
	B-20	Body wiring harness and instrument panel wiring harness combination	4-94, 95, 112	2-9
	B-21	Turn-signal and hazard warning flasher unit	4-66	2-9
	B-22	Stop lamp switch	4-41, 49, 68, 107, 111	2-9
	B-23	Ashtray illumination lamp	4-100	2-8
	B-24	Cigarette lighter illumination lamp	4-100	2-8
	B-25	Cigarette lighter	4-100	2-8

	Connector No.	Parts name	Circuit diagram page	Wiring diagram page
B	B-26	Cigarette lighter	4-100	2-8
	B-27	SRS-ECU	4-112, 113	2-8
	B-28	Diode (for ABS circuit)	4-104	2-8
	B-29	A/T-ECU	4-27, 35, 40, 41, 43, 44, 45, 46, 48, 49, 51, 52, 53, 54, 109	2-8
	B-30	A/T-ECU	4-35, 43, 44, 45, 46, 51, 52, 53, 54, 109	2-8
	B-31	A/T-ECU	4-35, 41, 42, 44, 45, 46, 49, 50, 51, 52, 53, 54, 86, 109	2-8
	B-32	Engine-ECU	4-21, 24, 25, 27, 28, 29, 30, 32, 33, 35, 36, 37, 38, 39, 83, 86	2-8
	B-33	Engine-ECU	4-24, 26, 27, 28, 32, 34, 35, 36, 37, 38, 44, 51, 52, 86, 108, 109	2-8
	B-34	Engine-ECU	4-20, 22, 25, 26, 27, 33, 34, 35, 43, 72, 109	2-8
	B-35	Engine-ECU	4-20, 24, 25, 26, 28, 29, 30, 32, 33, 34, 36, 37, 38, 43, 51, 109	2-8
	B-36	Body wiring harness and control wiring harness combination	4-19, 20, 24, 25, 26, 32, 33, 34, 40, 48, 69, 70, 84, 88	2-8
	B-37	Body wiring harness and control wiring harness combination <ABS>	4-104, 106, 107, 108, 110, 111	2-8
	B-38	Body wiring harness and control wiring harness combination <A/T>	4-41, 46, 49, 54	2-8
	B-39	J/B and roof wiring harness combination	4-4, 5, 64, 78, 79, 103	2-9
	B-40	J/B and instrument panel wiring harness combination	4-4, 5, 22, 26, 34, 40, 41, 48, 49, 60, 61, 62, 64, 66, 67, 72, 74, 85, 89, 92, 94, 96, 99, 100, 101, 104, 108, 110, 112	2-9
	B-41	Blower relay	4-73, 82	2-9
	B-42	Defogger relay	4-92	2-9
	B-43	J/B and body wiring harness combination	4-4, 5, 40, 41, 48, 49, 57, 59, 60, 61, 62, 63, 66, 67, 69, 70, 73, 85, 94, 96, 99, 100, 101, 102, 103, 108, 110	2-9
	B-44	J/B and body wiring harness combination	4-4, 5, 16, 17, 22, 26, 34, 39, 40, 48, 63, 66, 69, 70, 71, 72, 74, 76, 78, 80, 82, 88, 89, 90, 92, 95, 96, 98, 100, 101, 102, 103, 104, 108, 112	2-9
	B-45	J/B and body wiring harness combination	4-4, 5, 26, 34, 46, 54, 63, 67, 76, 78, 82, 85, 88, 90, 92, 95, 96, 103, 104, 106, 108, 112, 113	2-9



	Connector No.	Parts name	Circuit diagram page	Wiring diagram page
B	B-46	J/B and front wiring harness combination	4-4, 5, 17, 22, 26, 34, 39, 46, 54, 60, 61, 62, 63, 64, 66, 67, 70, 71, 72, 78, 80, 82, 85, 92, 96, 99, 101, 102, 104, 106, 108, 113	2-9
	B-47	J/B and front wiring harness combination	4-4, 5, 17, 78, 82, 92	2-9
	B-48	J/B and body wiring harness combination	4-4, 5, 60, 61, 62, 63, 64, 67, 70, 79, 80, 92, 96, 98, 101, 102, 103	2-9
	B-49	Buzzer-ECU	4-4, 5, 63, 70, 101, 102	2-9
	B-50	Blower motor	4-82	2-10
	B-51	Blower high speed relay	4-82	2-10
	B-52	ABS-ECU	4-104, 105, 106, 107, 111	2-10
	B-53	ABS-ECU	4-104, 106, 107, 111	2-10
	B-54	No connection	4-98	2-10
	B-55	Radio	4-96, 97, 98	2-10
	B-56	Diagnosis connector	4-46, 54	2-10
	B-57	Column switch	4-88, 90	2-11
	B-58	Steering wheel sensor <TCL>	4-110	2-11
	B-59	Column switch	4-57, 59, 60, 61, 62, 67, 101	2-11
	B-60	Column switch	4-57, 59	2-11
	B-61	J/C (6)	4-8, 18, 22, 56, 58, 71, 104	2-11
	B-62	Ignition switch	4-16	2-11
	B-63	Key reminder switch	4-63, 79, 101, 102	2-11
	B-64	Clock spring <SRS>	4-71	2-11
	B-65	Clock spring <SRS>	4-112	2-11
	B-66	Diagnosis code erasure connector <ABS>	4-106	2-10
	B-67	Shift switch assembly <A/T>	4-41, 49	2-10
	B-68	Oxygen sensor	4-29, 37	2-10
	B-69	No connection	-	2-10
	B-70	TCL-ECU	4-107, 108, 110, 111	2-10
	B-71	TCL-ECU	4-35, 51, 107, 108, 109, 110, 111	2-10
	B-72	Engine control relay	4-24, 32, 44, 52, 108	2-10
	B-73	Fuel pump relay	4-24, 32	2-10
	B-74	Diode (for ABS circuit)	4-105	2-10
	B-75	A/T control relay	4-44, 52	2-10

	Connector No.	Parts name	Circuit diagram page	Wiring diagram page
B	B-76	J/C (1)	4-6, 28, 29, 30, 36, 37, 38, 43, 44, 51, 52, 109	2-10
	B-77	Control wiring harness and instrument panel wiring harness combination	4-26, 34, 40, 48, 72, 73, 74, 75, 104, 108, 110	2-10
	B-78	Control wiring harness and instrument panel wiring harness combination <A/T>	4-41, 42, 49, 50	2-10
C	C-01	Instrument panel speaker (LH)	4-97	2-12
	C-02	Clock	4-99	2-12
	C-03	Voltmeter	4-73	2-12
	C-04	J/C (4)	4-7, 22, 26, 34, 41, 42, 49, 50, 62, 64, 66, 72, 73, 74, 89, 94, 98, 99, 104, 108, 110, 112	2-12
	C-05	Combination meter	4-22, 26, 34, 42, 50, 67, 72, 73, 74, 75, 104	2-12
	C-06	Combination meter	4-22, 26, 34, 57, 59, 64, 67, 72, 73, 74, 75, 89, 104, 108, 112	2-12
	C-07	Instrument panel speaker (RH)	4-97	2-12
	C-08	Fog lamp switch	4-62	2-12
	C-09	Remote controlled mirror switch	4-94, 95	2-12
	C-10	TCL switch	4-110	2-12
	C-11	Motor antenna switch	4-98	2-12
	C-12	Hazard warning switch	4-66	2-12
D	D-01	Door switch (RH)	4-63, 65, 79, 101, 102, 103	2-13
	D-02	Map lamp	4-64	2-13
	D-03	Sunroof switch	4-103	2-13
	D-04	Sunroof ECU	4-103	2-13
	D-05	Roof wiring harness and map lamp sub wiring harness combination	4-64	2-13
	D-06	Sunroof motor	4-103	2-13
	D-07	Defogger (+)	4-92	2-13
	D-08	High-mounted stop lamp	4-68	2-13
	D-09	Keyless entry receiver-ECU	4-65, 79, 80	2-13
	D-10	Defogger (-)	4-92	2-13
	D-11	Glass antenna	4-97	2-13
	D-12	Rear speed sensor (LH) <ABS>	4-106, 111	2-13
	D-13	Door switch (LH)	4-65, 79	2-13

	Connector No.	Parts name	Circuit diagram page	Wiring diagram page
D	D-14	Fuel pump assembly	4-25, 33, 72, 74	2-13
	D-15	Rear speed sensor (RH) <ABS>	4-106, 111	2-13
	D-16	Body wiring harness and defogger cable combination	4-92	2-13
	D-17	Body wiring harness and fuel wiring harness combination	4-25, 33, 72, 74, 106, 111	2-13
	D-18	Parking brake switch	4-75	2-13
	D-19	Seat belt switch	4-75	2-13
	D-20	No connection	-	2-13
E	E-01	Body wiring harness and door wiring harness (RH) combination	4-76, 77, 78, 95, 97	2-14
	E-02	Remote controlled mirror (RH)	4-95	2-14
	E-03	Power window main switch	4-76, 77	2-14
	E-04	Door lock actuator (RH)	4-78	2-14
	E-05	Power window motor (RH)	4-77	2-14
	E-06	Limit switch (RH)	4-77	2-14
	E-07	Door speaker (RH)	4-97	2-14
	E-08	Power window sub switch	4-76	2-14
	E-09	Remote controlled mirror (LH)	4-94	2-14
	E-10	Body wiring harness and door wiring harness (LH) combination	4-76, 78, 94, 97	2-14
	E-11	Door speaker (LH)	4-97	2-14
	E-12	Limit switch (LH)	4-76	2-14
	E-13	Power window motor (LH)	4-76	2-14
	E-14	Door lock actuator (LH)	4-78	2-14
F	F-01	Rear speaker (LH)	4-97	2-15
	F-02	Luggage compartment lamp	4-64	2-15
	F-03	Body wiring harness and rear wiring harness combination	4-60, 61, 64, 67, 68, 69, 70, 90, 97, 98	2-15
	F-04	Rear speaker (RH)	4-97	2-15
	F-05	Rear intermittent wiper relay	4-90	2-15
	F-06	Rear wiper motor	4-91	2-15
	F-07	Rear combination lamp (RH)	4-60, 61, 67, 68, 69, 70	2-15
	F-08	License plate lamp (RH)	4-60, 61	2-15

	Connector No.	Parts name	Circuit diagram page	Wiring diagram page
F	F-09	License plate lamp (LH)	4-60, 61	2-15
	F-10	Luggage compartment lamp switch	4-64	2-15
	F-11	Rear combination lamp (LH)	4-60, 61, 67, 68, 69, 70	2-15
	F-12	Motor antenna assembly	4-98	2-15

## INDEX (In order of parts name)

	Parts name	Connector No.	Circuit diagram page	Wiring diagram page
A	A/C compressor assembly	A-32	4-86	2-4
	A/C compressor relay	A-55X	4-13, 86	2-7
	A/C-ECU	B-08	4-82, 84, 85, 92	2-8
	A/C-ECU	B-09	4-82, 84, 85, 92	2-8
	A/T control relay	B-75	4-44, 52	2-10
	A/T control solenoid valve assembly	A-25	4-45, 53	2-5
	A/T-ECU	B-29	4-27, 35, 40, 41, 43, 44, 45, 46, 48, 49, 51, 52, 53, 54, 109	2-8
	A/T-ECU	B-30	4-35, 43, 44, 45, 46, 51, 52, 53, 54, 109	2-8
	A/T-ECU	B-31	4-35, 41, 42, 44, 45, 46, 49, 50, 51, 52, 53, 54, 86, 109	2-8
	ABS motor relay	A-53X	4-13, 105	2-7
	ABS valve relay	A-52X	4-13, 104	2-7
	ABS-ECU	B-52	4-104, 105, 106, 107, 111	2-10
	ABS-ECU	B-53	4-104, 106, 107, 111	2-10
	Accelerator pedal position sensor	A-08	4-36, 51, 109	2-5
	Air bag module (LH)	B-02	4-113	2-8
	Air mixing damper control motor and potentiometer <A/C>	B-06	4-84	2-8
	Air thermo sensor <A/C>	B-04	4-84	2-8
	Alternator	A-82	4-22	2-6
	Alternator	A-83	4-22	2-6
	Alternator relay	A-59X	4-13, 22	2-7
Ashtray illumination lamp	B-23	4-100	2-8	
Atmospheric pressure sensor	A-05	4-28, 36	2-4	
B	Back-up lamp switch <M/T>	A-27	4-69	2-5
	Blower high speed relay	B-51	4-82	2-10
	Blower motor	B-50	4-82	2-10
	Blower relay	B-41	4-73, 82	2-9
	Body wiring harness and control wiring harness combination	B-36	4-19, 20, 24, 25, 26, 32, 33, 34, 40, 48, 69, 70, 84, 88	2-8
	Body wiring harness and control wiring harness combination <A/T>	B-38	4-41, 46, 49, 54	2-8

	Parts name	Connector No.	Circuit diagram page	Wiring diagram page
B	Body wiring harness and control wiring harness combination <ABS>	B-37	4-104, 106, 107, 108, 110, 111	2-8
	Body wiring harness and defogger cable combination	D-16	4-92	2-13
	Body wiring harness and door wiring harness (LH) combination	E-10	4-76, 78, 94, 97	2-14
	Body wiring harness and door wiring harness (RH) combination	E-01	4-76, 77, 78, 95, 97	2-14
	Body wiring harness and fuel wiring harness combination	D-17	4-25, 33, 72, 74, 106, 111	2-13
	Body wiring harness and instrument panel wiring harness combination	B-19	4-42, 50, 57, 59, 62, 66, 67, 72, 73, 74, 75, 89, 92, 94, 97, 98, 99	2-9
	Body wiring harness and instrument panel wiring harness combination	B-20	4-94, 95, 112	2-9
	Body wiring harness and rear wiring harness combination	F-03	4-60, 61, 64, 67, 68, 69, 70, 90, 97, 98	2-15
	Body wiring harness and roof wiring harness combination	B-15	4-64, 65, 68, 79, 103	2-9
	Brake fluid level sensor	A-01	4-75	2-4
	Buzzer-ECU	B-49	4-4, 5, 63, 70, 101, 102	2-9
C	Camshaft position sensor	A-90	4-30, 38	2-6
	Capacitor	A-45	4-21, 25, 33	2-7
	Capacitor	A-47	4-20, 25, 33	2-7
	Cigarette lighter	B-25	4-100	2-8
	Cigarette lighter	B-26	4-100	2-8
	Cigarette lighter illumination lamp	B-24	4-100	2-8
	Clock	C-02	4-99	2-12
	Clock spring <SRS>	B-64	4-71	2-11
	Clock spring <SRS>	B-65	4-112	2-11
	Column switch	B-57	4-88, 90	2-11
	Column switch	B-59	4-57, 59, 60, 61, 62, 67, 101	2-11
	Column switch	B-60	4-57, 59	2-11
	Combination meter	C-05	4-22, 26, 34, 42, 50, 67, 72, 73, 74, 75, 104	2-12
	Combination meter	C-06	4-22, 26, 34, 57, 59, 64, 67, 72, 73, 74, 75, 89, 104, 108, 112	2-12
	Condenser fan motor	A-34	4-39, 83	2-4

	Parts name	Connector No.	Circuit diagram page	Wiring diagram page
C	Condenser fan relay	A-56X	4-13, 39, 83	2-7
	Control wiring harness and battery cable combination	A-12	4-19	2-5
	Control wiring harness and front wiring harness combination	A-13	4-22, 24, 27, 32, 35, 39, 44, 52, 74, 75, 83, 86, 104, 108	2-5
	Control wiring harness and front wiring harness combination <ABS>	A-14	4-104, 105, 106, 111	2-5
	Control wiring harness and injector wiring harness combination	A-18	4-22, 28, 29, 36, 37	2-5
	Control wiring harness and instrument panel wiring harness combination	B-77	4-26, 34, 40, 48, 72, 73, 74, 75, 104, 108, 110	2-10
	Control wiring harness and instrument panel wiring harness combination <A/T>	B-78	4-41, 42, 49, 50	2-10
	Crank angle sensor	A-91	4-30, 38, 44, 52	2-6
D	Defogger (+)	D-07	4-92	2-13
	Defogger (-)	D-10	4-92	2-13
	Defogger relay	B-42	4-92	2-9
	Detonation sensor	A-19	4-30, 38	2-5
	Diagnosis code erasure connector <ABS>	B-66	4-106	2-10
	Diagnosis connector	B-11	4-26, 34, 46, 54, 80, 85, 106, 110, 113	2-8
	Diagnosis connector	B-56	4-46, 54	2-10
	Diode (for ABS circuit)	B-28	4-104	2-8
	Diode (for ABS circuit)	B-74	4-105	2-10
	Door lock actuator (LH)	E-14	4-78	2-14
	Door lock actuator (RH)	E-04	4-78	2-14
	Door lock-ECU	B-12	4-78	2-9
	Door speaker (LH)	E-11	4-97	2-14
	Door speaker (RH)	E-07	4-97	2-14
	Door switch (LH)	D-13	4-65, 79	2-13
	Door switch (RH)	D-01	4-63, 65, 79, 101, 102, 103	2-13
Dual pressure switch	A-11	4-86	2-5	
E	Engine control relay	B-72	4-24, 32, 44, 52, 108	2-10
	Engine coolant temperature gauge unit	A-26	4-73	2-5
	Engine coolant temperature sensor	A-75	4-29, 37	2-7

	Parts name	Connector No.	Circuit diagram page	Wiring diagram page
E	Engine speed detection connector	A-48	4-20, 25, 33, 72	2-7
	Engine-ECU	B-32	4-21, 24, 25, 27, 28, 29, 30, 32, 33, 35, 36, 37, 38, 39, 83, 86	2-8
	Engine-ECU	B-33	4-24, 26, 27, 28, 32, 34, 35, 36, 37, 38, 44, 51, 52, 86, 108, 109	2-8
	Engine-ECU	B-34	4-20, 22, 25, 26, 27, 33, 34, 35, 43, 72, 109	2-8
	Engine-ECU	B-35	4-20, 24, 25, 26, 28, 29, 30, 32, 33, 34, 36, 37, 38, 43, 51, 109	2-8
F	Fog lamp (LH)	A-71	4-62	2-7
	Fog lamp (RH)	A-84	4-62	2-6
	Fog lamp switch	C-08	4-62	2-12
	Front speed sensor (LH) <ABS>	A-16	4-106, 111	2-5
	Front speed sensor (RH) <ABS>	A-38	4-106, 111	2-4
	Front turn signal lamp (LH)	A-70	4-67	2-7
	Front turn signal lamp (RH)	A-85	4-67	2-6
	Front wiring harness and body wiring harness combination	B-16	4-14, 15, 103	2-9
	Front wiring harness and body wiring harness combination	B-17	4-41, 49, 56, 57, 58, 59, 60, 61, 62, 68, 71, 76, 88, 89, 90, 101, 107, 111	2-9
	Front wiring harness and oil pressure wiring harness combination	A-80	4-74	2-6
	Fuel pump assembly	D-14	4-25, 33, 72, 74	2-13
Fuel pump relay	B-73	4-24, 32	2-10	
G	Glass antenna	D-11	4-97	2-13
H	Hazard warning switch	C-12	4-66	2-12
	Headlamp (LH)	A-69	4-56, 58	2-7
	Headlamp (LH) <discharge type>	A-66	4-58, 61	2-7
	Headlamp (LH) <except discharge type>	A-67	4-56	2-7
	Headlamp (RH)	A-86	4-56, 58	2-6
	Headlamp (RH) <discharge type>	A-89	4-58, 61	2-6
	Headlamp (RH) <except discharge type>	A-88	4-56	2-6
	Headlamp relay	A-54X	4-13, 18, 56, 58	2-7
	Headlamp relay <vehicles with discharge type headlamp>	A-61X	4-13, 18, 58	2-7



	Parts name	Connector No.	Circuit diagram page	Wiring diagram page
H	Heater water temperature sensor <A/C>	B-07	4-84	2-8
	High-mounted stop lamp	D-08	4-68	2-13
	Horn (HI)	A-36	4-71	2-4
	Horn (HI)	A-37	4-71	2-4
	Horn (LO)	A-20	4-71	2-5
	Horn (LO)	A-21	4-71	2-5
	Horn relay	A-58X	4-13, 71	2-7
	Hydraulic unit <ABS>	A-50	4-105	2-7
	Hydraulic unit <ABS>	A-51	4-105	2-7
I	Idle speed control servo	A-09	4-28, 36	2-5
	Ignition coil A	A-29	4-21, 25, 33	2-4
	Ignition coil B	A-30	4-21, 25, 33	2-4
	Ignition coil C	A-28	4-21, 25, 33	2-5
	Ignition failure sensor	A-65	4-20, 25, 33	2-7
	Ignition switch	B-62	4-16	2-11
	Inhibitor switch <A/T>	A-74	4-19, 24, 32, 40, 48, 70	2-7
	Injector No.1	A-41	4-28, 36	2-6
	Injector No.2	A-81	4-28, 36	2-6
	Injector No.3	A-42	4-29, 37	2-6
	Injector No.4	A-79	4-29, 37	2-6
	Injector No.5	A-43	4-29, 37	2-6
	Injector No.6	A-78	4-29, 37	2-6
	Input shaft speed sensor <A/T>	A-73	4-46, 54	2-7
	Instrument panel speaker (LH)	C-01	4-97	2-12
	Instrument panel speaker (RH)	C-07	4-97	2-12
	Intake air temperature sensor	A-04	4-29, 36	2-4
J	J/B and body wiring harness combination	B-43	4-4, 5, 40, 41, 48, 49, 57, 59, 60, 61, 62, 63, 66, 67, 69, 70, 73, 85, 94, 96, 99, 100, 101, 102, 103, 108, 110	2-9
	J/B and body wiring harness combination	B-44	4-4, 5, 16, 17, 22, 26, 34, 39, 40, 48, 63, 66, 69, 70, 71, 72, 74, 76, 78, 80, 82, 88, 89, 90, 92, 95, 96, 98, 100, 101, 102, 103, 104, 108, 112	2-9

	Parts name	Connector No.	Circuit diagram page	Wiring diagram page
J	J/B and body wiring harness combination	B-45	4-4, 5, 26, 34, 46, 54, 63, 67, 76, 78, 82, 85, 88, 90, 92, 95, 96, 103, 104, 106, 108, 112, 113	2-9
	J/B and body wiring harness combination	B-48	4-4, 5, 60, 61, 62, 63, 64, 67, 70, 79, 80, 92, 96, 98, 101, 102, 103	2-9
	J/B and front wiring harness combination	B-46	4-4, 5, 17, 22, 26, 34, 39, 46, 54, 60, 61, 62, 63, 64, 66, 67, 70, 71, 72, 78, 80, 82, 85, 92, 96, 99, 101, 102, 104, 106, 108, 113	2-9
	J/B and front wiring harness combination	B-47	4-4, 5, 17, 78, 82, 92	2-9
	J/B and instrument panel wiring harness combination	B-40	4-4, 5, 22, 26, 34, 40, 41, 48, 49, 60, 61, 62, 64, 66, 67, 72, 74, 85, 89, 92, 94, 96, 99, 100, 101, 104, 108, 110, 112	2-9
	J/B and roof wiring harness combination	B-39	4-4, 5, 64, 78, 79, 103	2-9
	J/C (1)	B-76	4-6, 28, 29, 30, 36, 37, 38, 43, 44, 51, 52, 109	2-10
	J/C (2)	B-13	4-6, 57, 59, 60, 61, 62, 65, 66, 71, 79, 88, 90, 95, 101, 102, 103	2-9
	J/C (3)	B-14	4-7, 41, 42, 49, 50, 62, 63, 67, 68, 73, 78, 85, 92, 94, 96, 98, 99, 100, 107, 108, 110, 111	2-9
	J/C (4)	C-04	4-7, 22, 26, 34, 41, 42, 49, 50, 62, 64, 66, 72, 73, 74, 89, 94, 98, 99, 104, 108, 110, 112	2-12
	J/C (5)	B-18	4-8, 14, 85, 103	2-9
	J/C (6)	B-61	4-8, 18, 22, 56, 58, 71, 104	2-11
K	Key reminder switch	B-63	4-63, 79, 101, 102	2-11
	Keyless entry receiver-ECU	D-09	4-65, 79, 80	2-13
L	License plate lamp (LH)	F-09	4-60, 61	2-15
	License plate lamp (RH)	F-08	4-60, 61	2-15
	Limit switch (LH)	E-12	4-76	2-14
	Limit switch (RH)	E-06	4-77	2-14
	Luggage compartment lamp	F-02	4-64	2-15
	Luggage compartment lamp switch	F-10	4-64	2-15
M	Map lamp	D-02	4-64	2-13
	Mode selection damper control motor and potentiometer <A/C>	B-10	4-84	2-8
	Motor antenna assembly	F-12	4-98	2-15

	Parts name	Connector No.	Circuit diagram page	Wiring diagram page
M	Motor antenna switch	C-11	4-98	2-12
N	No connection	A-62X	4-13	2-7
	No connection	A-63X	4-13	2-7
	No connection	A-64X	4-13	2-7
	No connection	B-54	4-98	2-10
	No connection	B-69	-	2-10
	No connection	D-20	-	2-13
O	Oil control valve (left bank side)	A-40	4-28, 36	2-6
	Oil control valve (right bank side)	A-17	4-28, 36	2-5
	Oil pressure switch	A-31	4-74	2-4
	Output shaft speed sensor <A/T>	A-72	4-46, 54	2-7
	Outside thermo sensor <A/C>	A-35	4-85	2-4
	Outside/inside air selection damper control motor <A/C>	B-01	4-84	2-8
	Oxygen sensor	B-68	4-29, 37	2-10
P	Parking brake switch	D-18	4-75	2-13
	Photo sensor <A/C>	B-05	4-85	2-8
	Position lamp (LH) <vehicles without discharge type headlamp>	A-68	4-60	2-7
	Position lamp (RH) <vehicles without discharge type headlamp>	A-87	4-60	2-6
	Power steering oil pressure switch	A-33	4-27, 35	2-4
	Power transistor <A/C>	B-03	4-82	2-8
	Power window main switch	E-03	4-76, 77	2-14
	Power window motor (LH)	E-13	4-76	2-14
	Power window motor (RH)	E-05	4-77	2-14
	Power window relay	A-60X	4-13, 76	2-7
	Power window sub switch	E-08	4-76	2-14
R	Radiator fan motor	A-24	4-39, 83	2-5
	Radiator fan relay	A-57X	4-13, 39, 83	2-7
	Radio	B-55	4-96, 97, 98	2-10
	Rear combination lamp (LH)	F-11	4-60, 61, 67, 68, 69, 70	2-15
	Rear combination lamp (RH)	F-07	4-60, 61, 67, 68, 69, 70	2-15

	Parts name	Connector No.	Circuit diagram page	Wiring diagram page
R	Rear intermittent wiper relay	F-05	4-90	2-15
	Rear speaker (LH)	F-01	4-97	2-15
	Rear speaker (RH)	F-04	4-97	2-15
	Rear speed sensor (LH) <ABS>	D-12	4-106, 111	2-13
	Rear speed sensor (RH) <ABS>	D-15	4-106, 111	2-13
	Rear washer motor	A-23	4-90	2-5
	Rear wiper motor	F-06	4-91	2-15
	Remote controlled mirror (LH)	E-09	4-94	2-14
	Remote controlled mirror (RH)	E-02	4-95	2-14
	Remote controlled mirror switch	C-09	4-94, 95	2-12
	Roof wiring harness and map lamp sub wiring harness combination	D-05	4-64	2-13
S	Seat belt switch	D-19	4-75	2-13
	Shift switch assembly <A/T>	B-67	4-41, 49	2-10
	Side turn signal lamp (LH)	A-15	4-67	2-5
	Side turn signal lamp (RH)	A-39	4-67	2-4
	SRS-ECU	B-27	4-112, 113	2-8
	Starter	A-76	4-19	2-6
	Starter	A-77	4-19	2-6
	Steering wheel sensor <TCL>	B-58	4-110	2-11
	Stop lamp switch	B-22	4-41, 49, 68, 107, 111	2-9
	Sunroof ECU	D-04	4-103	2-13
	Sunroof motor	D-06	4-103	2-13
	Sunroof switch	D-03	4-103	2-13
	T	TCL switch	C-10	4-110
TCL-ECU		B-70	4-107, 108, 110, 111	2-10
TCL-ECU		B-71	4-35, 51, 107, 108, 109, 110, 111	2-10
Throttle position sensor		A-07	4-28, 36, 43, 51, 109	2-5
Turn-signal and hazard warning flasher unit		B-21	4-66	2-9
V	Vacuum solenoid valve <TCL>	A-44	4-38	2-7
	Variable induction control servo	A-02	4-28, 37	2-4
	Variable induction control servo	A-03	4-28, 37	2-4

	Parts name	Connector No.	Circuit diagram page	Wiring diagram page
V	Vehicle speed sensor	A-06	4-26, 34, 40, 48, 72	2-4
	Ventilation solenoid valve <TCL>	A-46	4-38	2-7
	Voltmeter	C-03	4-73	2-12
W	Windshield washer motor	A-22	4-89	2-5
	Windshield wiper motor	A-10	4-89	2-5