

WIRING DIAGRAMS

Article Text

1990 Mitsubishi Galant

For (095) 723-1791 Kirill

Copyright © 1998 Mitchell Repair Information Company, LLC

Thursday, December 16, 1999 01:10PM

ARTICLE BEGINNING

1990 Wiring Diagrams
Mitsubishi

Galant

COMPONENT LOCATION MENU

COMPONENT LOCATIONS TABLE

AA

Component	(Figure No.)	Location
A/C SYSTEM	10	(A-B 36-39)
ABS CONTROL UNIT (2WD)	7	(A-B 24)
ABS CONTROL UNIT (4WD)	7	(D-E 24)
ABS HYDRAULIC UNIT (2WD)	7	(A-B 27)
ABS HYDRAULIC UNIT (4WD)	7	(D-E 27)
ABS POWER RELAY (2WD)	7	(C 27)
ABS POWER RELAY (4WD)	7	(D 27)
ABS PRES SW (4WD)	7	(D 27)
ALTERNATOR	1	(D 3)
ALTERNATOR RELAY	1	(E 3)
ANTENNA RELAY	12	(A 46)
AUTO SEAT BELTS	8	(D-E 28-31)
BACK-UP LT SW (M/T)	9	(D 32)
BATTERY	1	(A 2)
CIG LIGHTER	8	(C 28)
CLOCK	11	(D 40)
COLUMN SW	10	(E 36-39)
COMP RELAY	6	(A 21)
CONDENSER FAN RLY (HI)	4	(A 14)
CONDENSER FAN RLY (LO)	4	(A 14)
CRUISE CONTROL DIODE	9	(A 33)
CRUISE CONTROL SW (COLUMN SW)	9	(A 33-34)
CRUISE CONTROL UNIT	9	(B 32)
DEFOG RELAY	11	(E 41)
DEFOG SW	11	(E 41)
DIAG CONN (2.0L DOHC)	3	(E 6)
DIAG CONN (2.0L SOHC)	3	(E 11)
DIR/HAZ FLASHER	10	(B 37)
DOME LT	8	(C 28)
DOME LT & SUNROOF SW	8	(A 28)
DOOR SWS & LTS	8	(B-C 29-31)
ECS CONTROL UNIT	6	(B-E 20)
ECS INDICATORS	6	(C-E 23)
ECS POWER RELAY	6	(B 23)
ELECT A/T CONTROL SYS	9	(A-B 35)
ELECT POWER STEERING	9	(A-B 35)
ENGINE COOLANT TEMP SW (2.0L DOHC)	2	(A 7)
ENGINE FUSE/RELAY (F/R) BOX	4	(B-E 13, 15)
ETACS CONTROL UNIT	10	(B-C 36)

WIRING DIAGRAMS

Article Text (p. 2)

1990 Mitsubishi Galant

For (095) 723-1791 Kirill

Copyright © 1998 Mitchell Repair Information Company, LLC

Thursday, December 16, 1999 01:10PM

FUEL PUMP GAUGE UNIT (4WD)	11 (B 43)
FUS LINK BOX	1 (B 3)
HAZARD SW	10 (C 38)
HEATER CONTROL ILLUM LIGHT	8 (C 30)
IGNITION COIL (2.0L DOHC)	2 (D 4)
IGNITION COIL (2.0L SOHC)	3 (D 8)
ILLUM LTS	8 (D 28)
INHIBITOR SW A/T)	9 (D 32)
INSTRUMENT CLUSTER	11 (A-C 40-43)
JUNCTION BLOCK (J/B)	5 (A-C 16-18)
JUNCTION CONNS	11 (D 42-43)
MPI CONTROL RLY 2.0L DOHC)	2 (B 4)
MPI CONTROL RLY (2.0L SOHC)	3 (E 8)
MPI CTRL UNIT (DOHC)	2 (A 4-7)
MPI CTRL UNIT SOHC)	3 (A 8-11)
POWER DOOR LOCKS	12 (A-B 44-45)
POWER MIRROR	12 (C 44-45)
POWER TRANSISTOR (2.0L DOHC)	2 (E 4)
POWER WINDOWS	12 (D-E 44-46)
STARTER MOTOR	1 (C 3)
STARTER RELAY (M/T)	1 (D 3)
STOP LT SW (W/CRUISE CONTROL)	8 (A 32)
STOP LT SW (W/O CRUISE CONTROL)	12 (C 47)
SUNROOF POWER RELAY	8 (B 28)
THROTTLE POSITION SENSOR	
2.0L DOHC	3 (C 7)
2.0L SOHC	3 (B 11)
VANITY MIRROR LT	8 (A 30)
WIPER SYSTEM	10 (C-E 39)
AA	

WIRING DIAGRAMS

WIRING DIAGRAMS

Article Text (p. 3)

1990 Mitsubishi Galant

For (095) 723-1791 Kirill

Copyright © 1998 Mitchell Repair Information Company, LLC

Thursday, December 16, 1999 01:10PM

COMPONENT LOCATOR:

A/C SYSTEM	A-B 36-39
ABS CONTROL UNIT (2WD)	A-3 24
ABS CONTROL UNIT (4WD)	D-E 24
ABS HYDRAULIC UNIT (2WD)	A-B 27
ABS HYDRAULIC UNIT (4WD)	D-E 27
ABS POWER RELAY (2WD)	C 27
ABS POWER RELAY (4WD)	D 27
ABS PRES SW (4WD)	D 26
ALTERNATOR	D 3
ALTERNATOR RELAY	E 3
ANTENNA RELAY	A 46
AUTO SEAT BELTS	D-E 28-31
BACK-UP LT SW (M/T)	D 32
BATTERY	A 2
CIG LIGHTER	C 28
CLOCK	D 40
CLUTCH SW (M/T)	A 32
COLUMN SW	D-E 36-39
COMP RELAY	A 21
CONDENSER FAN RELAY (HI)	A 14
CONDENSER FAN RELAY (LO)	A 14
CRUISE CONTROL SW (COLUMN SW)	A 33-34
CRUISE CONTROL UNIT	B 32
DEFOG RELAY	E 41
DEFOG SW	E 41
DIAG CONN (2.0L DOHC)	E 11
DIAG CONN (2.0L SOHC)	E 11
DIR/HAZ FLASHER	B 37
DOVE LT	C 23
DOVE LT & SUNROOF SW	A 28
DOOR SWs & LTS	B-C 29-31
ECS CONTROL UNIT	B-E 20
ECS INDICATORS	O-E 23
ECS POWER RELAY	B 23
ELECT POWER STEERING (EPS) SYS	A-B 35
ELECTRONIC A/T CONTROL SYS	C-E 32-35
ENGINE COOLANT TEMP SW (2.0L DOHC)	A 7
ENGINE FUSE/RELAY BOX (ENG F/R BOX)	B-E 13-15
ETACS CONTROL UNIT	B-C 36
FUEL PUMP GAUGE UNIT (4WD)	B 43
FUS LINK BOX	B 3
HAZARD SW	C 38
HEATER CONTROL ILLUM LT	C 30
IGNITION COIL (2.0L DOHC)	D 4
IGNITION COIL (2.0L SOHC)	D 9
ILLUM LTS	D 28
INHIBITOR SW (A/T)	D 32
INST CLSTR	A-E 40-43
JUNCTION BLOCK (J/B)	A-D 16-18
JUNCTION CONNS	D 42-43
MPI CONTROL RELAY (2.0L DOHC)	B 4
MPI CONTROL RELAY (2.0L SOHC)	E 9
MPI CONTROL UNIT (2.0L DOHC)	A 4-7
MPI CONTROL UNIT (2.0L SOHC)	A 8-11
POWER DOOR LOCKS	A-B 44-45
POWER MIRRORS	C 44-45
POWER TRANSISTOR (2.0L DOHC)	E 4
POWER WINDOWS	D-F 44-46
STARTER MOTOR	C 3
STARTER RELAY (M/T)	D 3
STOP LT SW (W/ CRUISE CONTROL)	A 32
STOP LT SW (W/O CRUISE CONTROL)	C 47
SUNROOF POWER RELAY	B 28
THROTTLE POSITION SENS (2.0L DOHC)	C 7
THROTTLE POSITION SENS (2.0L SOHC)	B 11
VANITY MIRROR LT	A 30
WIPER SYSTEM	C-E 39

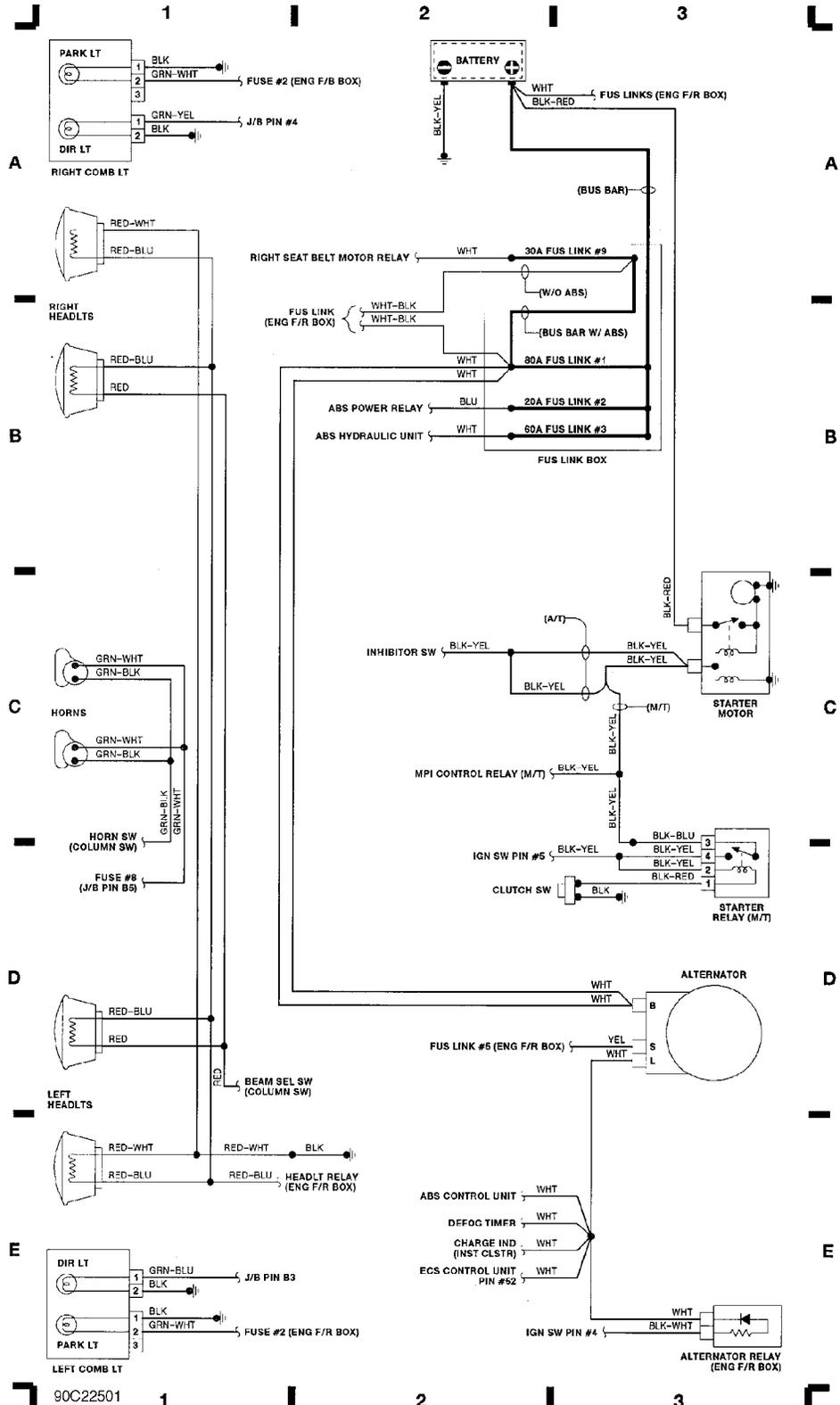

Fig. 1: Engine Compartment & Headlights (Grid 1-3)

WIRING DIAGRAMS
Article Text (p. 4)
 1990 Mitsubishi Galant
 For (095) 723-1791 Kirill
 Copyright © 1998 Mitchell Repair Information Company, LLC
 Thursday, December 16, 1999 01:10PM

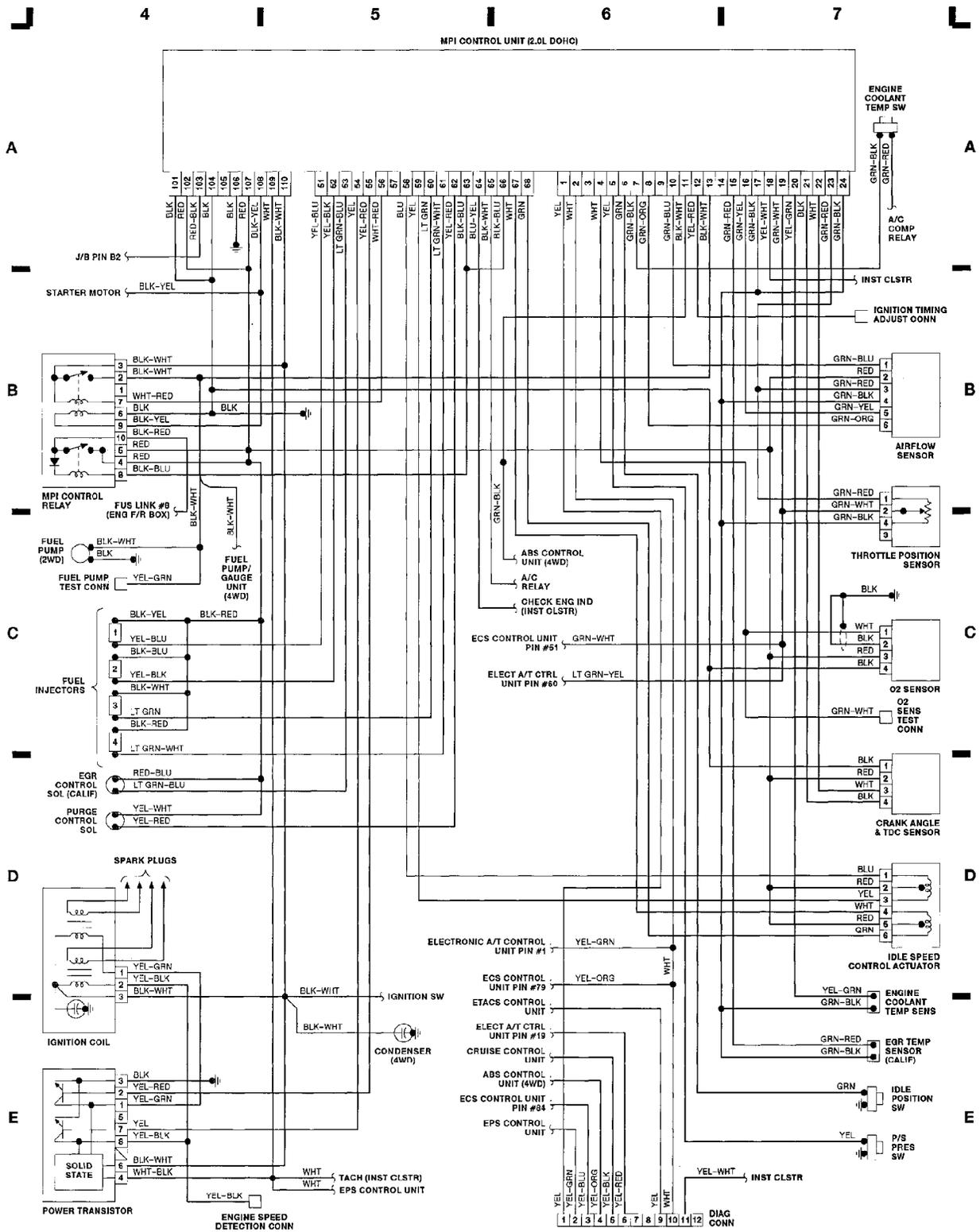

Fig. 2: Computer Engine Control (2.0L DOHC) (Grid 4-7)

WIRING DIAGRAMS

Article Text (p. 5)

1990 Mitsubishi Galant

For (095) 723-1791 Kirill

Copyright © 1998 Mitchell Repair Information Company, LLC

Thursday, December 16, 1999 01:10PM

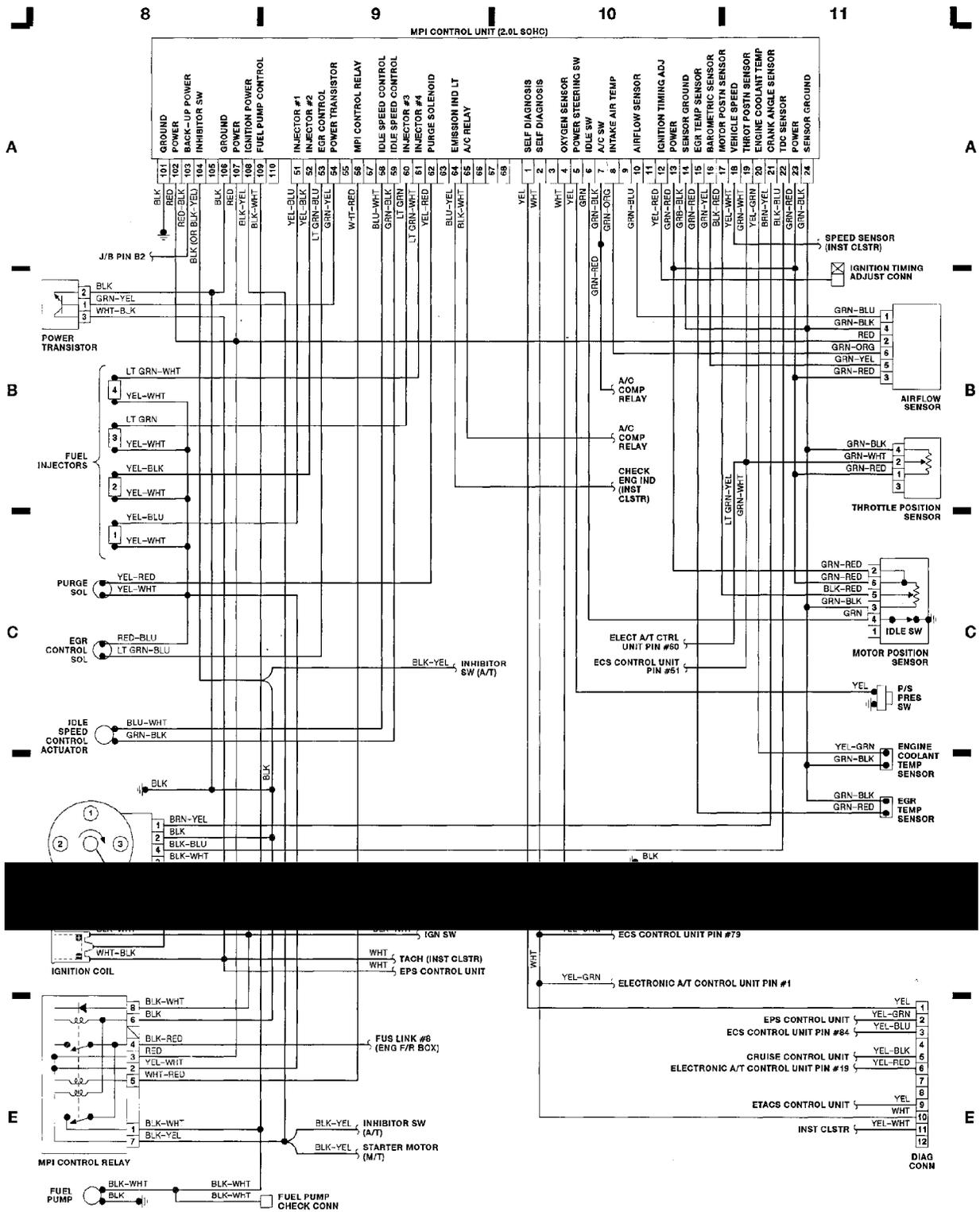

Fig. 3: Computer Engine Control (2.0L SOHC) (Grid 8-11)

WIRING DIAGRAMS

Article Text (p. 6)

1990 Mitsubishi Galant

For (095) 723-1791 Kirill

Copyright © 1998 Mitchell Repair Information Company, LLC

Thursday, December 16, 1999 01:10PM

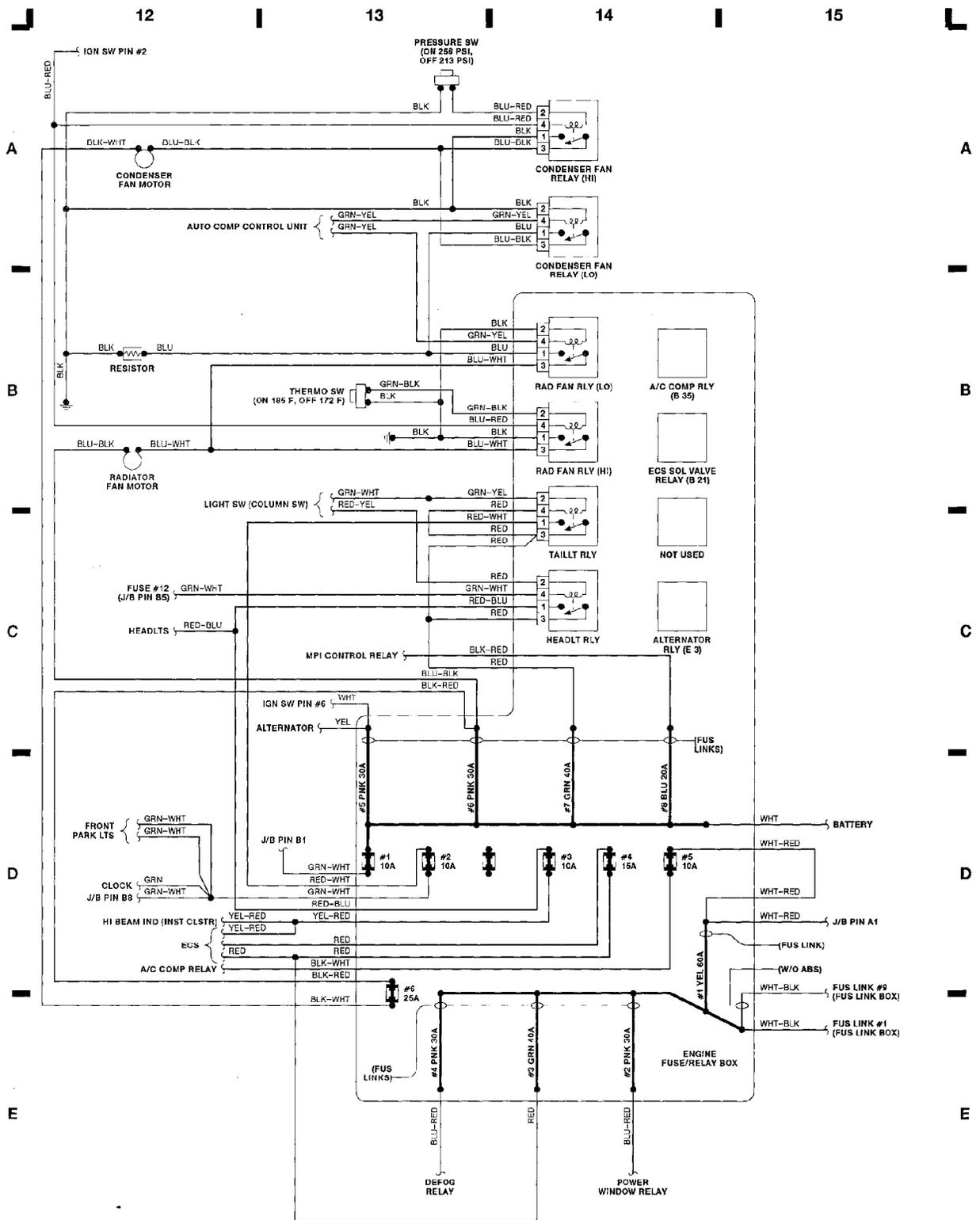

Fig. 4: Fuse Block and Relays (Grid 12-15)

WIRING DIAGRAMS
Article Text (p. 7)
 1990 Mitsubishi Galant
 For (095) 723-1791 Kirill
 Copyright © 1998 Mitchell Repair Information Company, LLC
 Thursday, December 16, 1999 01:10PM

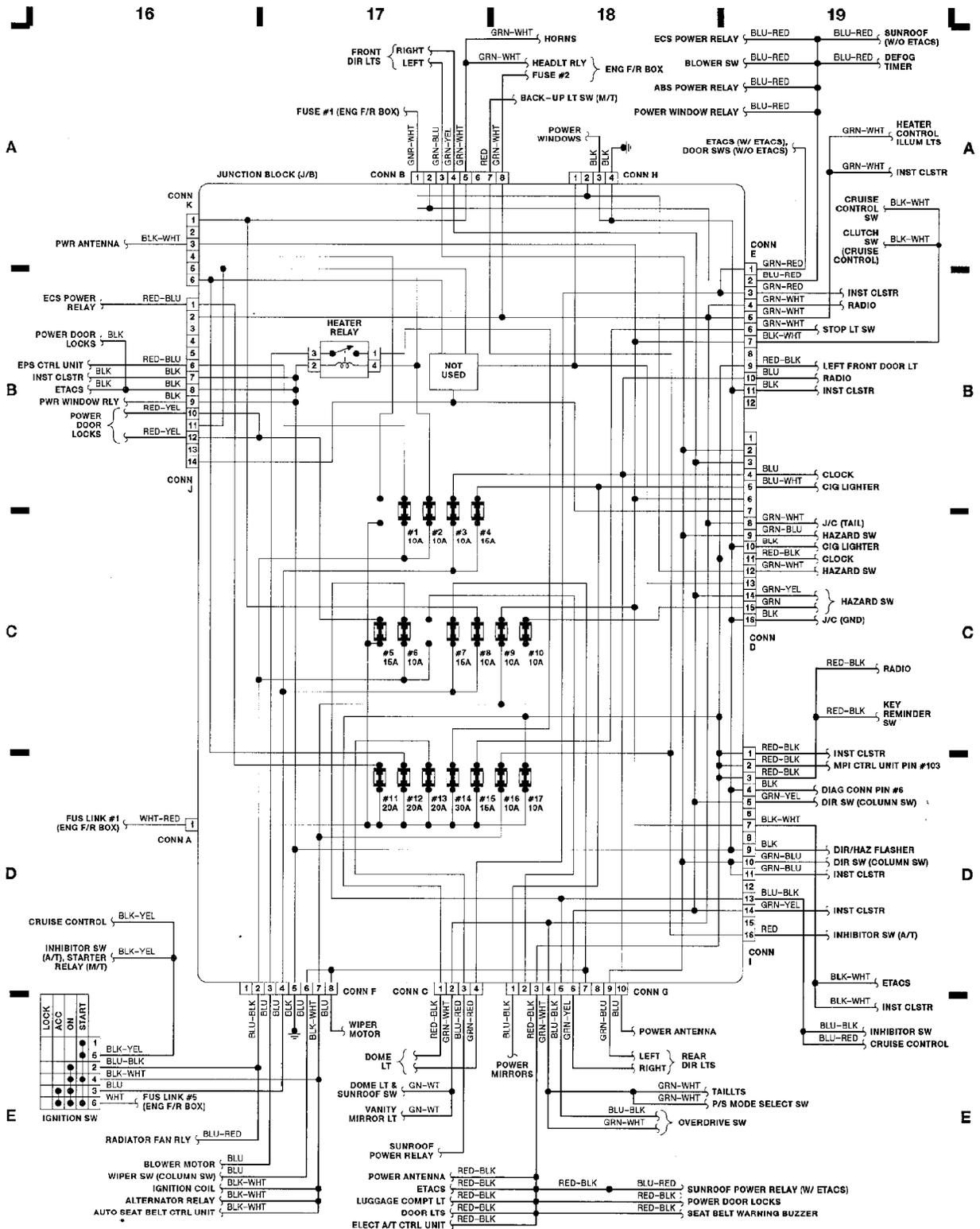

Fig. 5: Fuse Block (Continued) (Grid 16-19)

WIRING DIAGRAMS
Article Text (p. 8)
 1990 Mitsubishi Galant
 For (095) 723-1791 Kirill
 Copyright © 1998 Mitchell Repair Information Company, LLC
 Thursday, December 16, 1999 01:10PM

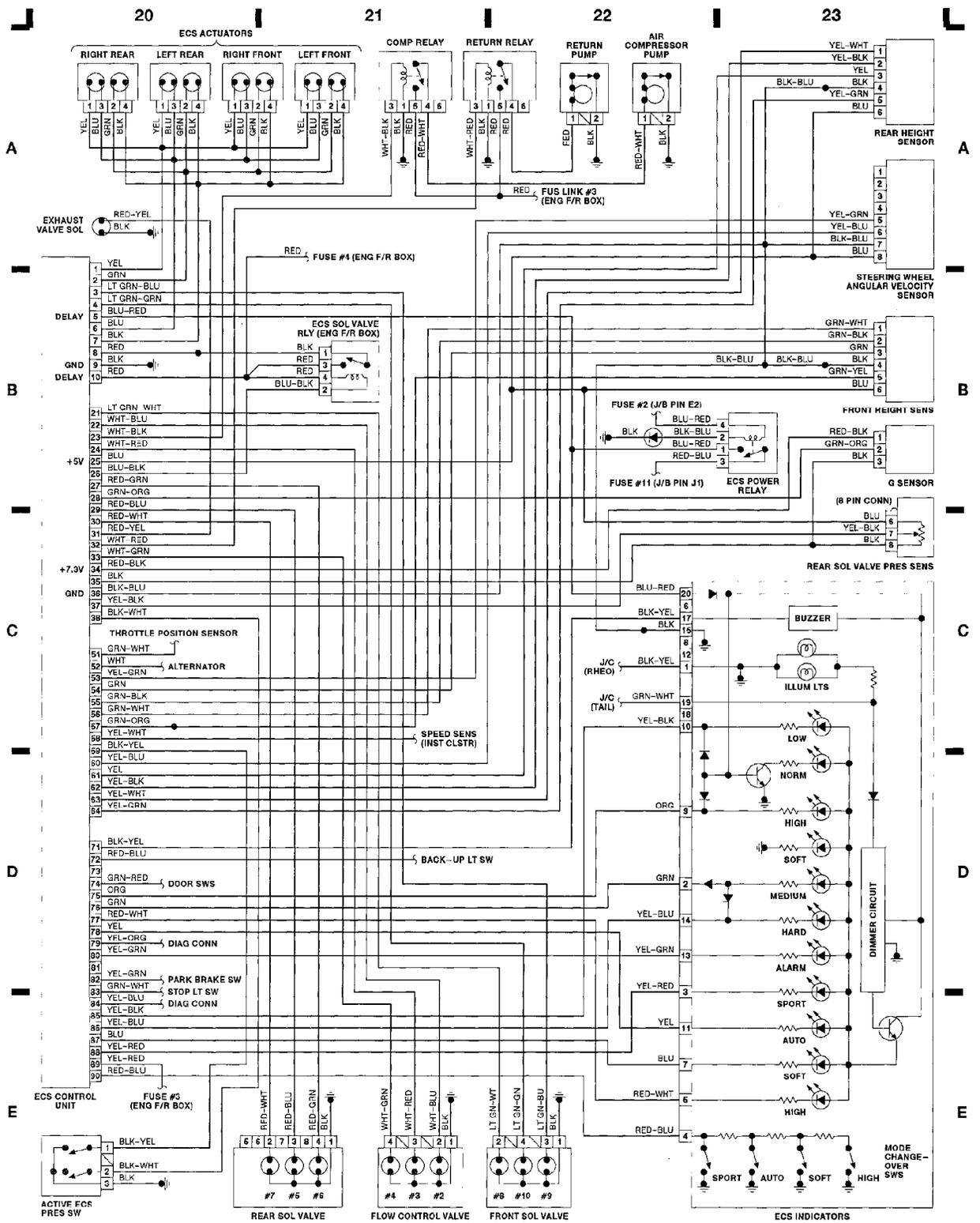

Fig. 6: Electronic Control Suspension System (ECS) (Grid 20-23)

WIRING DIAGRAMS
Article Text (p. 9)
 1990 Mitsubishi Galant
 For (095) 723-1791 Kirill
 Copyright © 1998 Mitchell Repair Information Company, LLC
 Thursday, December 16, 1999 01:10PM

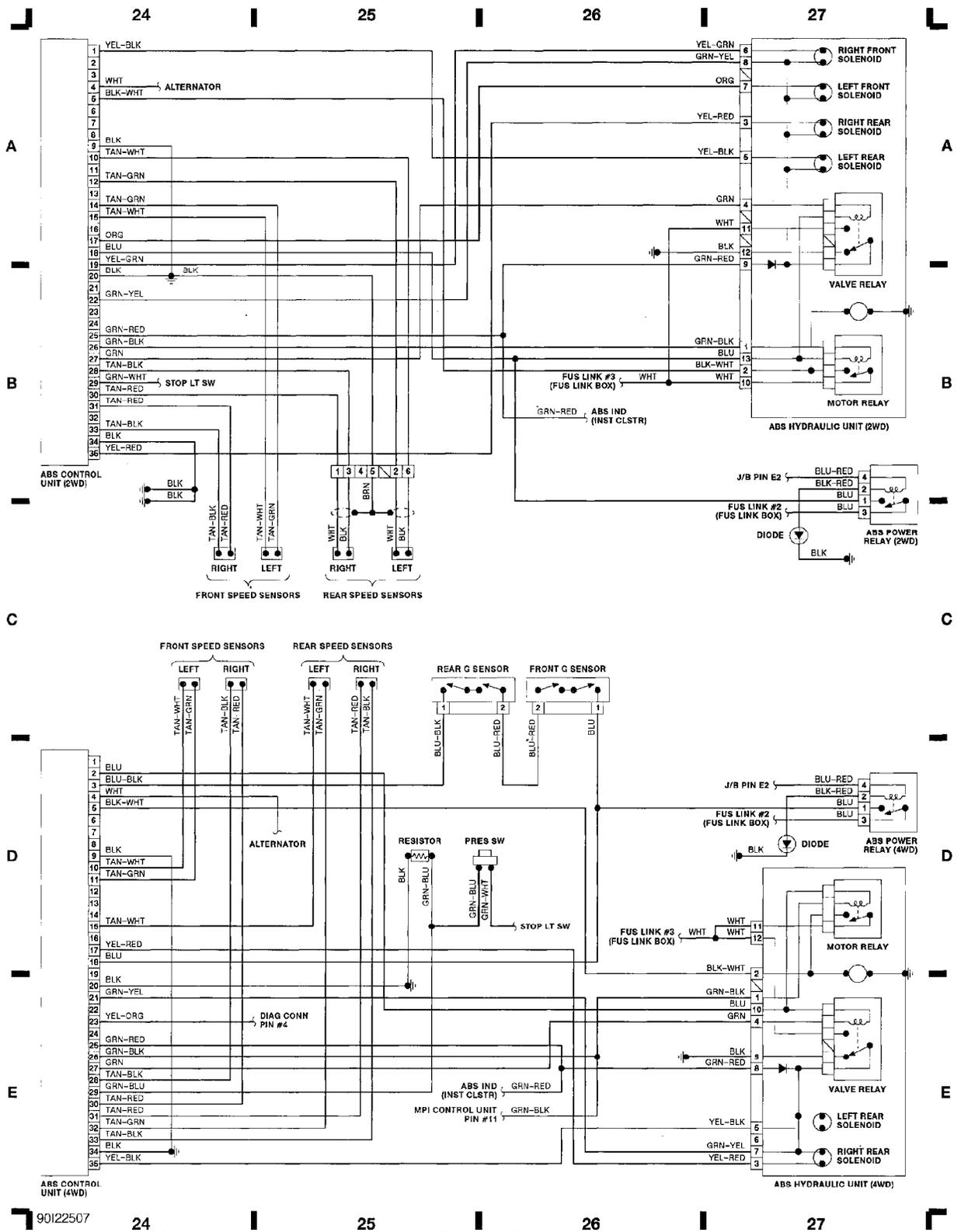
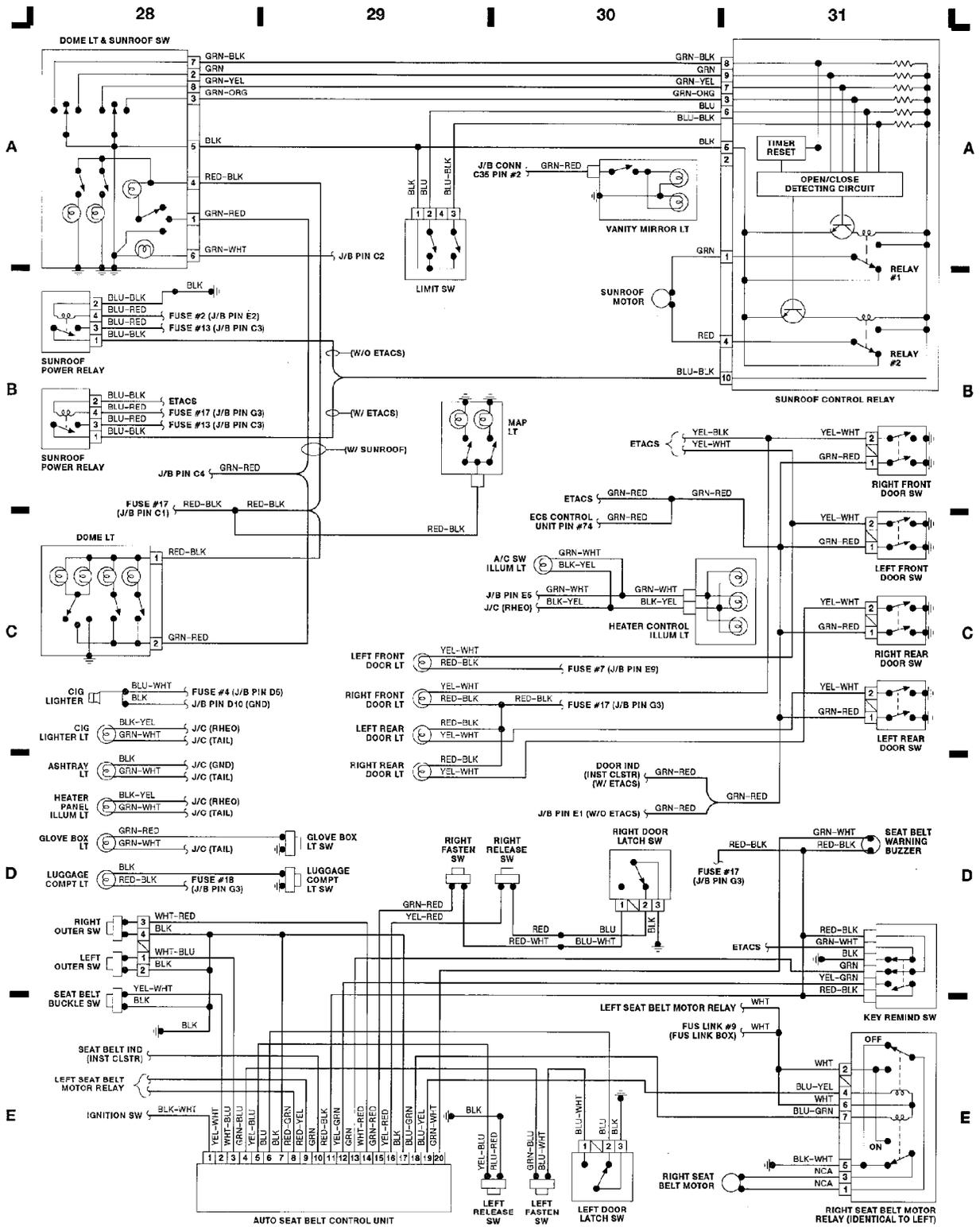

Fig. 7: Anti-Lock Brake System (ABS) (Grid 24-27)

WIRING DIAGRAMS
Article Text (p. 10)
 1990 Mitsubishi Galant
 For (095) 723-1791 Kirill
 Copyright © 1998 Mitchell Repair Information Company, LLC
 Thursday, December 16, 1999 01:10PM



90J22508
 Fig. 8: Auto Seat Belt, Sunroof, Interior Lights (Grid 28-31)

WIRING DIAGRAMS

Article Text (p. 11)

1990 Mitsubishi Galant

For (095) 723-1791 Kirill

Copyright © 1998 Mitchell Repair Information Company, LLC

Thursday, December 16, 1999 01:10PM

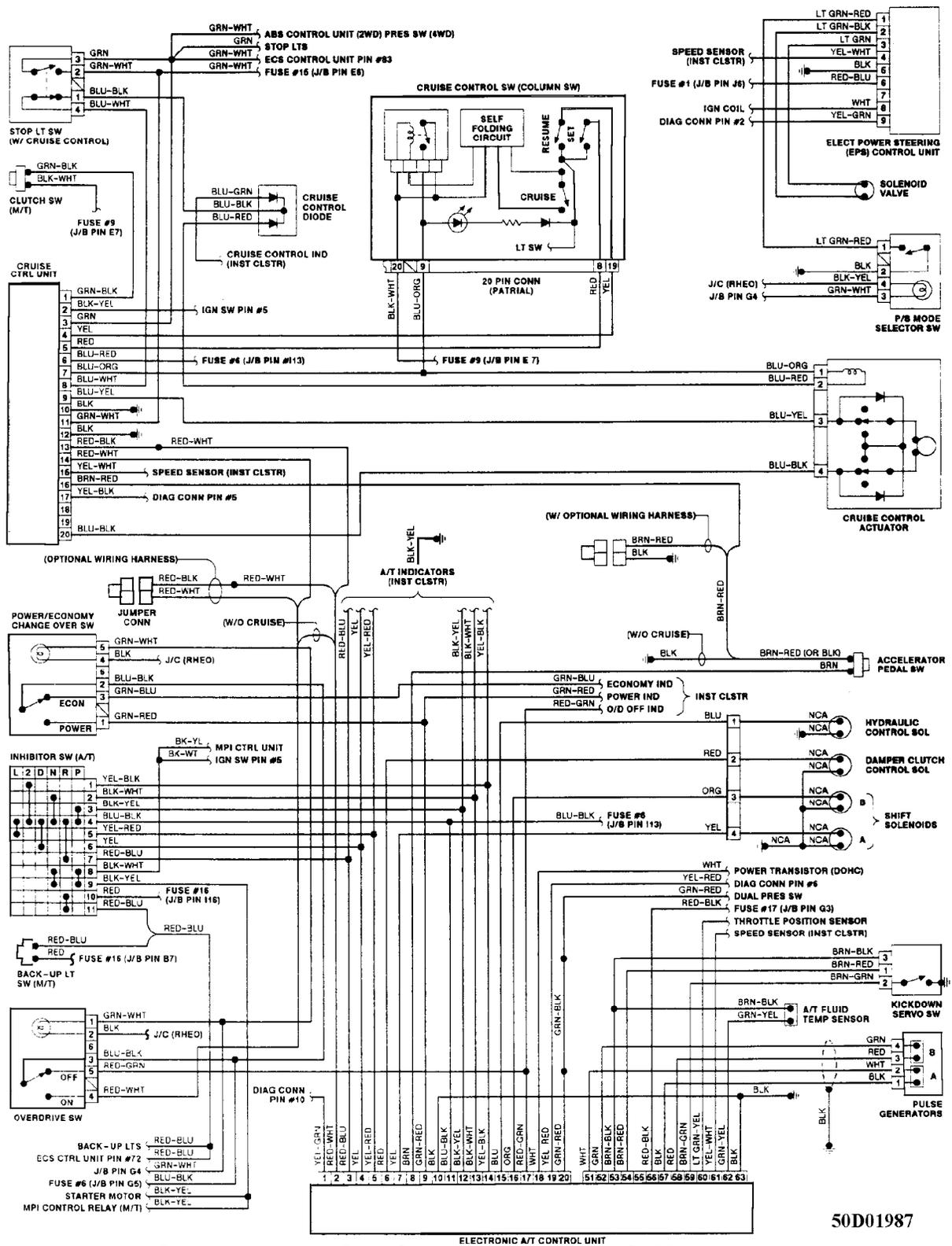

50D01987

Fig. 9: Cruise Control, A/T Control, Electric P/S (Grid 32-35)

WIRING DIAGRAMS

Article Text (p. 12)

1990 Mitsubishi Galant

For (095) 723-1791 Kirill

Copyright © 1998 Mitchell Repair Information Company, LLC

Thursday, December 16, 1999 01:10PM

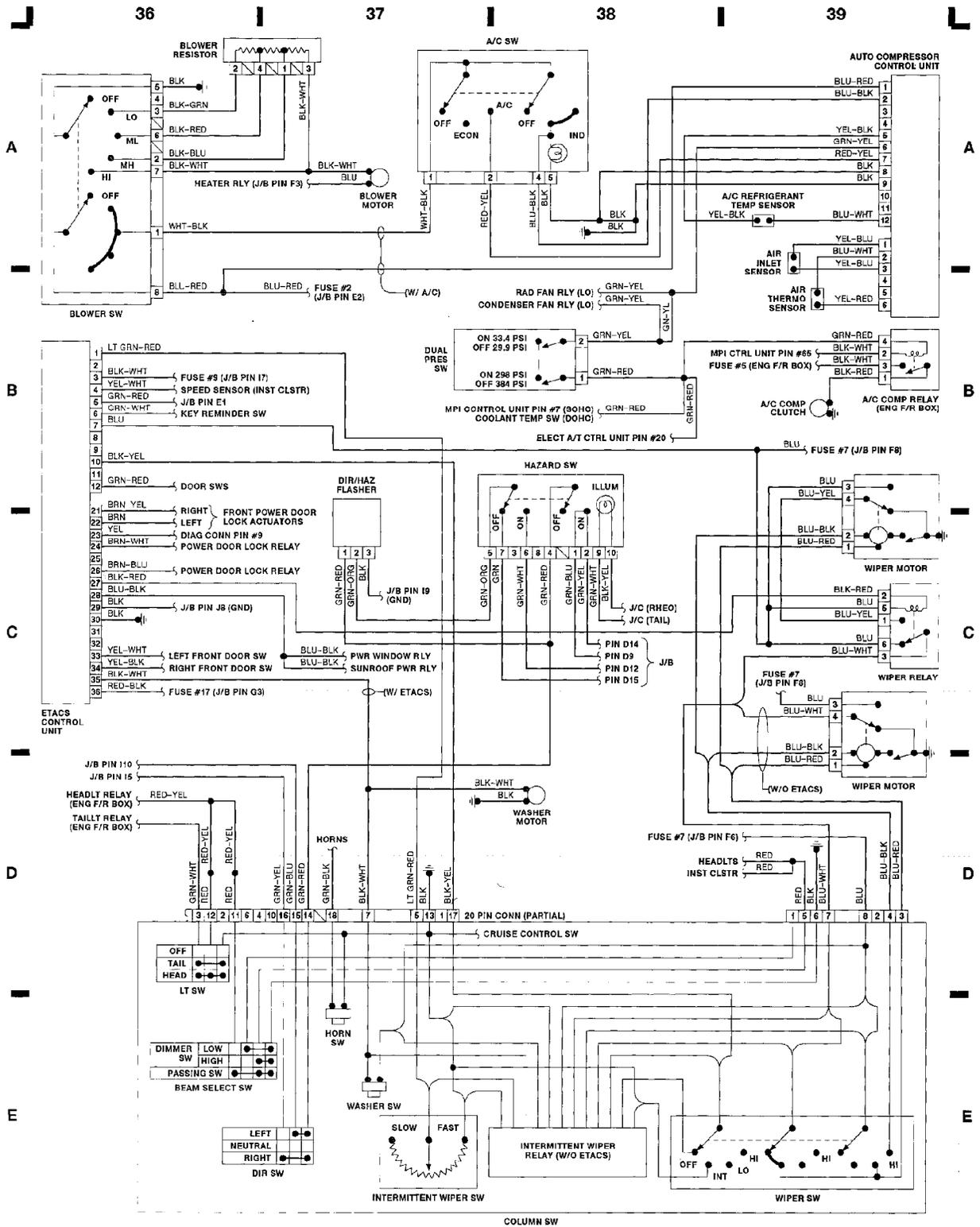

Fig. 10: ETACS Ctrl, Column Sw, Wiper/Washer, A/C Ctrl (Grid 36-39)

WIRING DIAGRAMS
Article Text (p. 13)
 1990 Mitsubishi Galant
 For (095) 723-1791 Kirill
 Copyright © 1998 Mitchell Repair Information Company, LLC
 Thursday, December 16, 1999 01:10PM

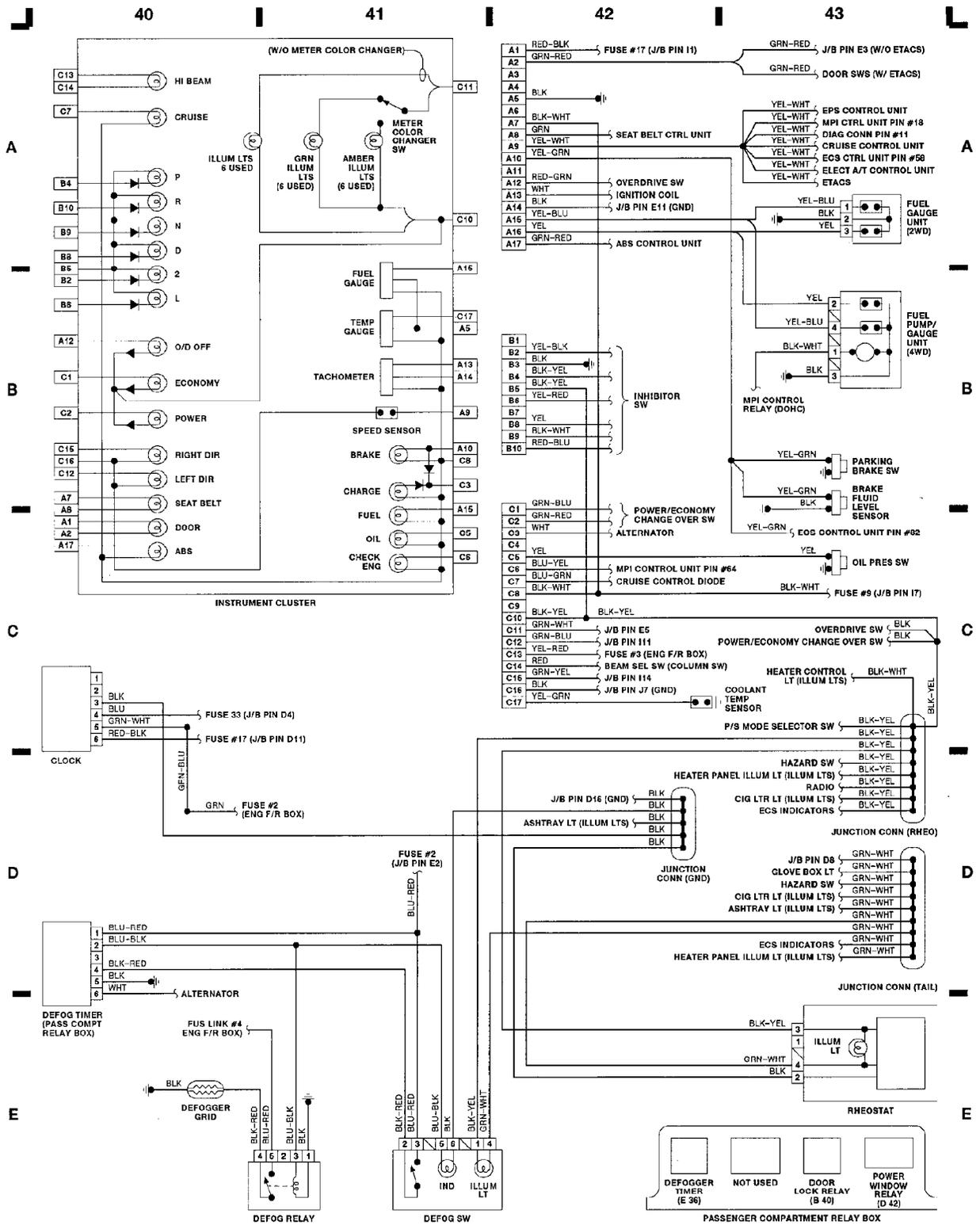

Fig. 11: Defog Sys, Junction Conns, Instrument Cluster (Grid 40-43)

WIRING DIAGRAMS
Article Text (p. 14)
 1990 Mitsubishi Galant
 For (095) 723-1791 Kirill
 Copyright © 1998 Mitchell Repair Information Company, LLC
 Thursday, December 16, 1999 01:10PM

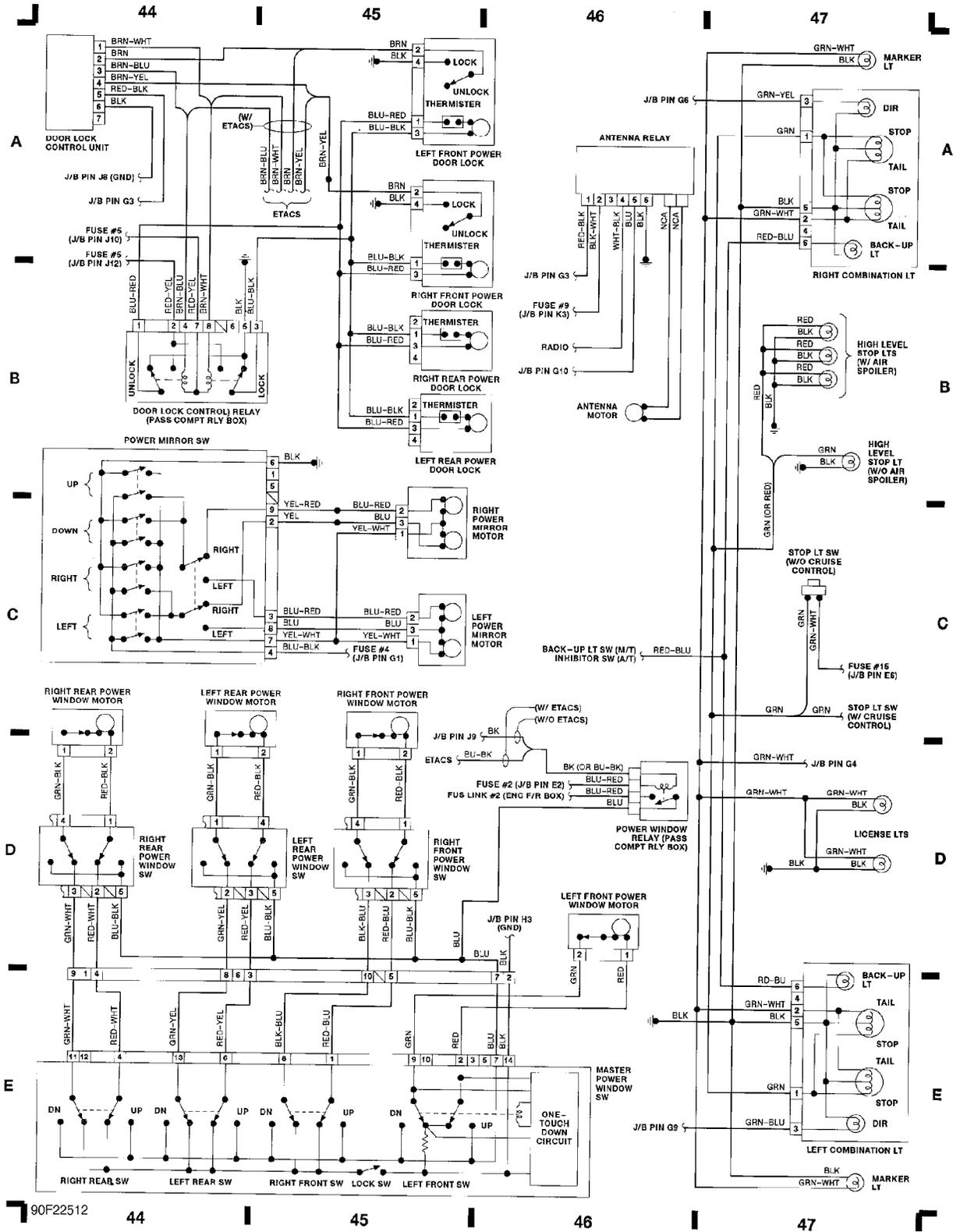

Fig. 12: Power Window/Mirrors/Door Locks & Taillights (Grid 44-47)

END OF ARTICLE