

4 CORROSION PROTECTION

BODY SEALING LOCATIONS	4-2
[SEDAN]	
FLOOR	4-2
UPPER BODY	4-2
SIDE BODY	4-2
[HATCHBACK]	
FLOOR	4-4
UPPER BODY	4-4
SIDE BODY	4-4
WAX INJECTION LOCATIONS	4-6
ANTICORROSION PRIMER LOCATIONS	4-11
UNDERCOAT APPLICATION LOCATIONS	4-11
UNDERBODY ANTICORROSION	
AGENT LOCATIONS	4-12

BODY SEALING LOCATIONS

NOTES WITH REGARD TO REPAIR WORK

In places where the sealant can be directly seen on surfaces such as the drip rails, pillars or clinch, and where the appearance of the paint surface is important, apply sealant or wipe away sealant after application to make the amount of sealant even. Be careful not to cover the drain hole.

[SEDAN]

FLOOR

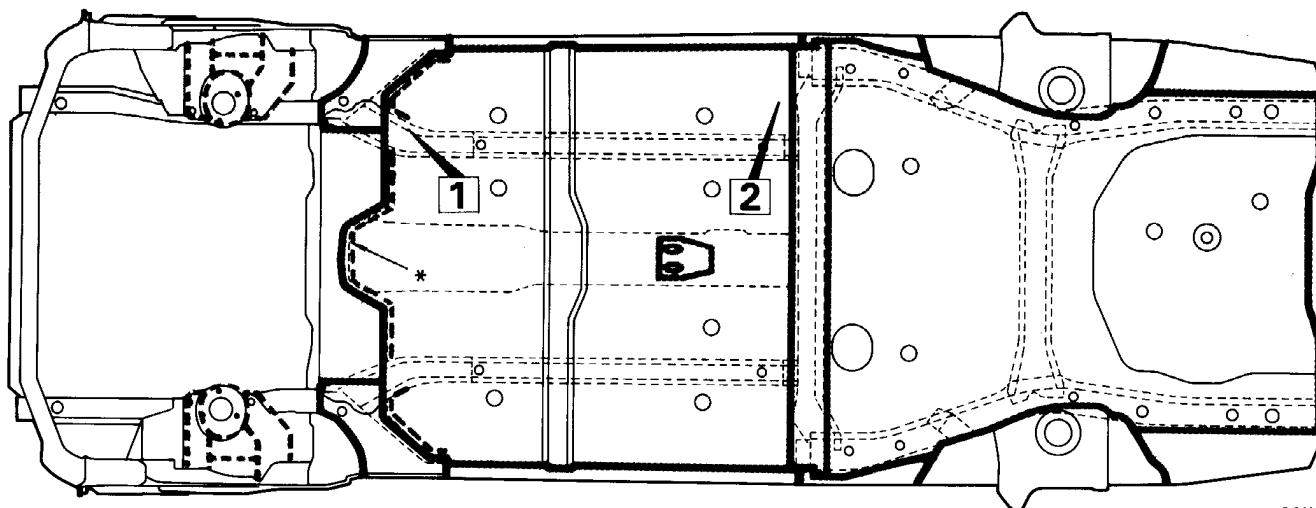

30X0089

UPPER BODY

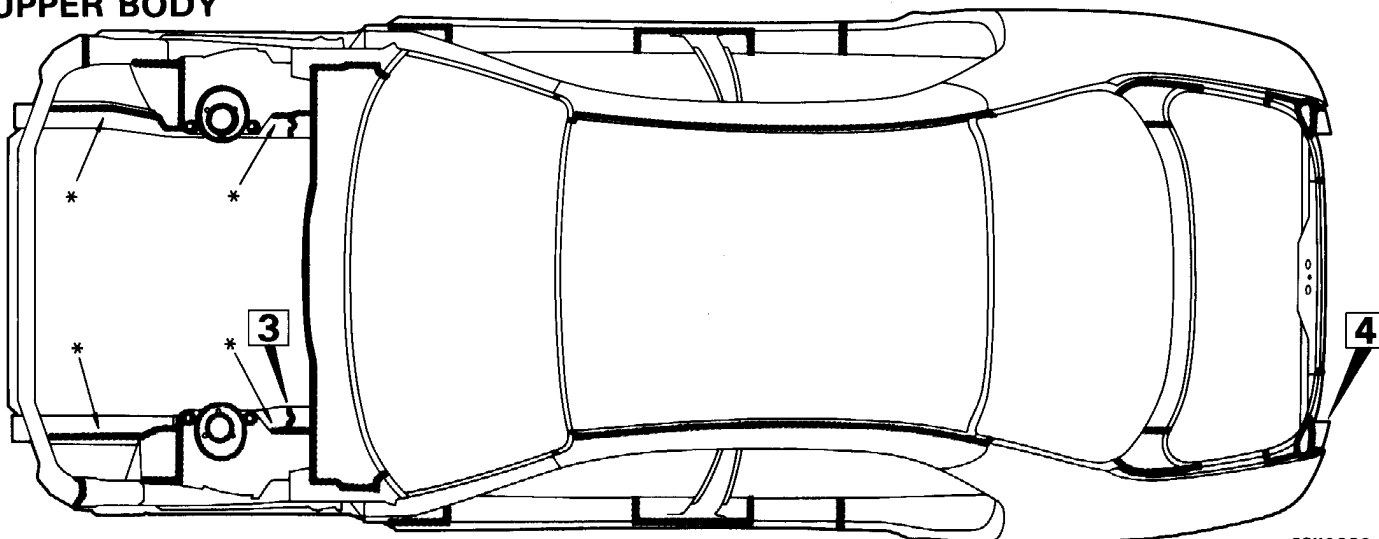

30X0090

SIDE BODY

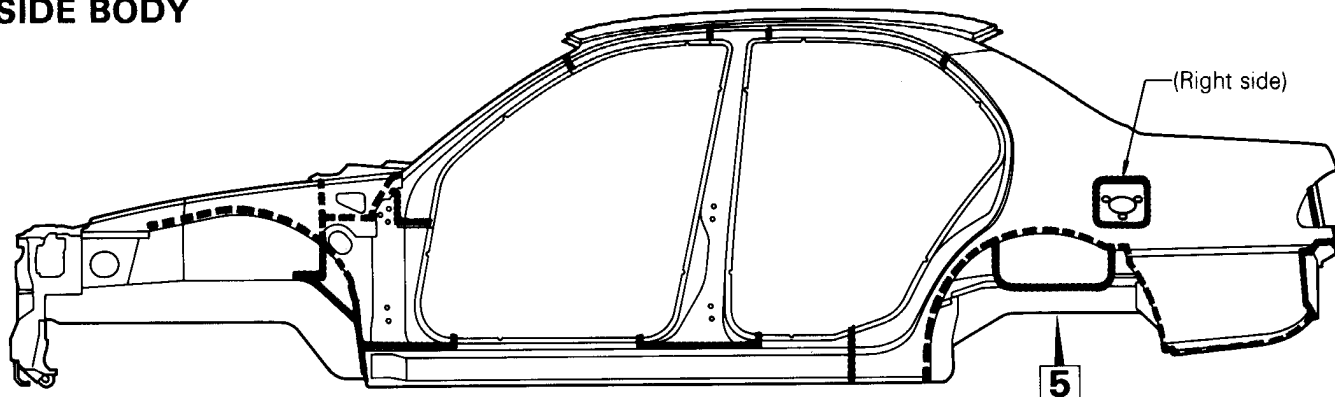

NOTE
* : Vehicles for Europe

30X0007

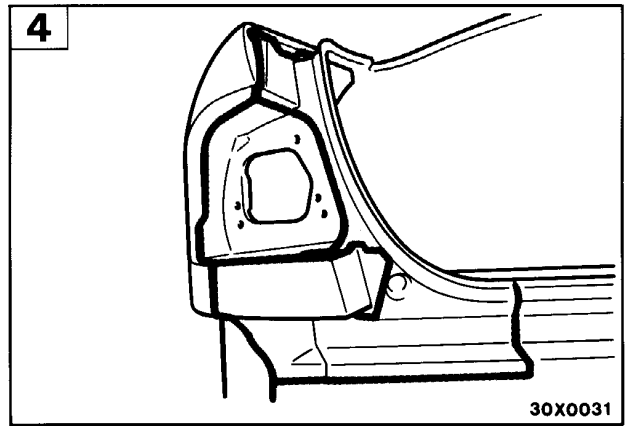
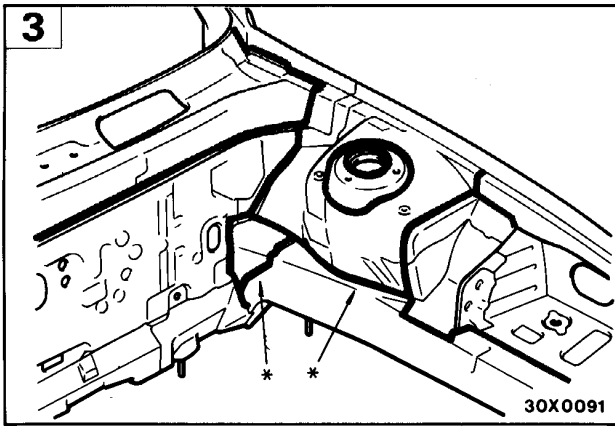
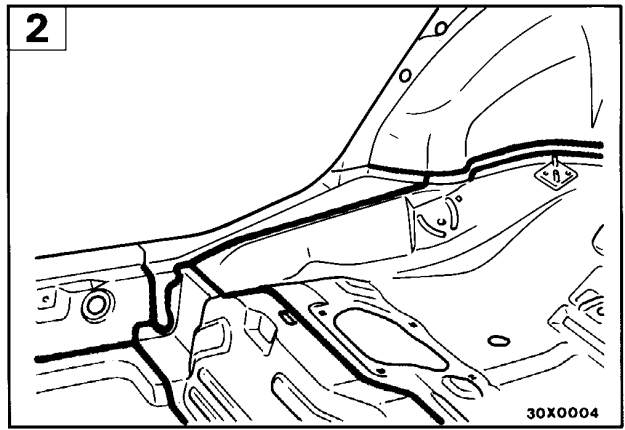
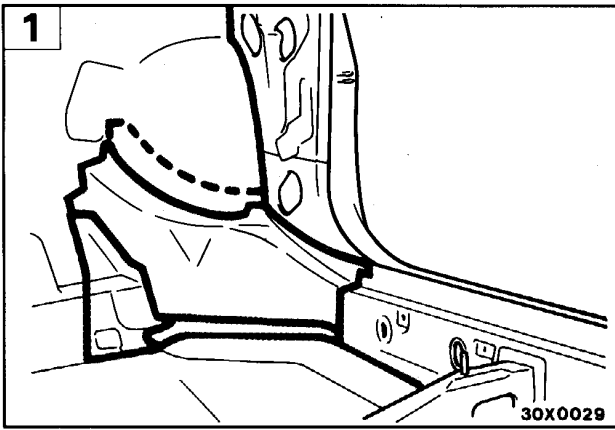

4

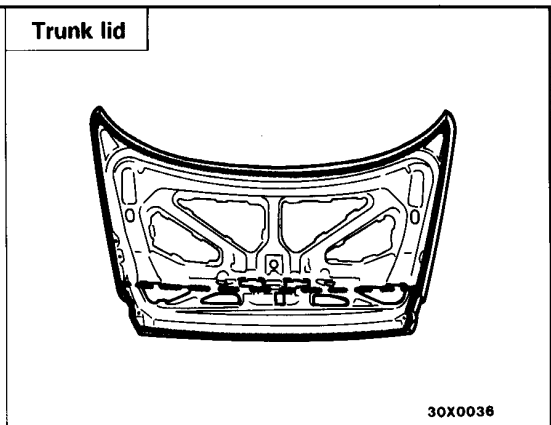
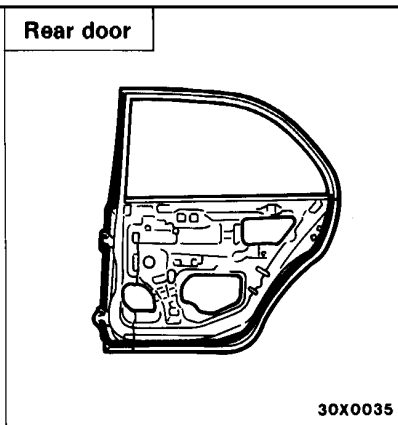
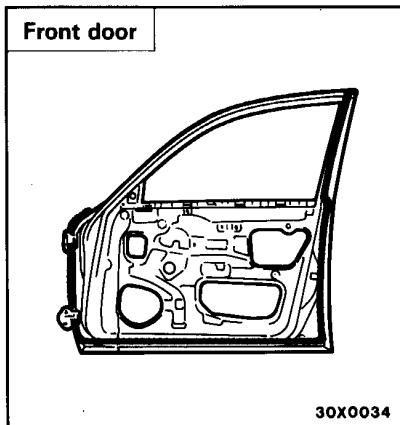
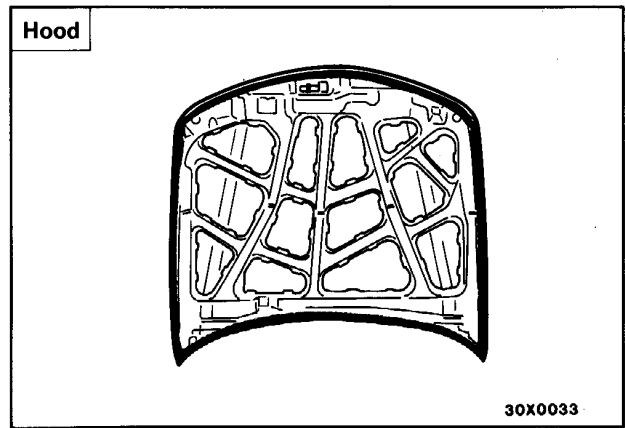
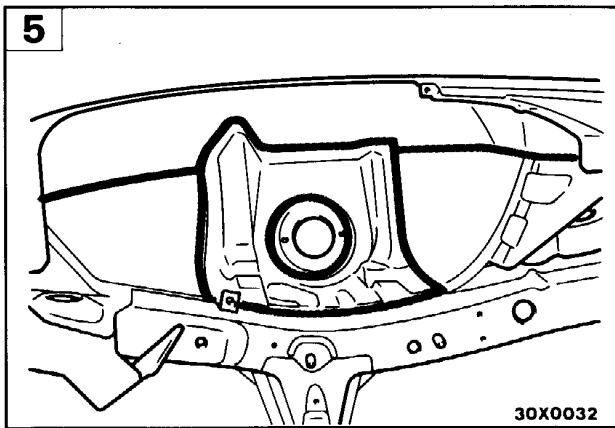

NOTE *: Vehicles for Europe

4-4 CORROSION PROTECTION – Body Sealing Locations [HATCHBACK]

[HATCHBACK]

FLOOR

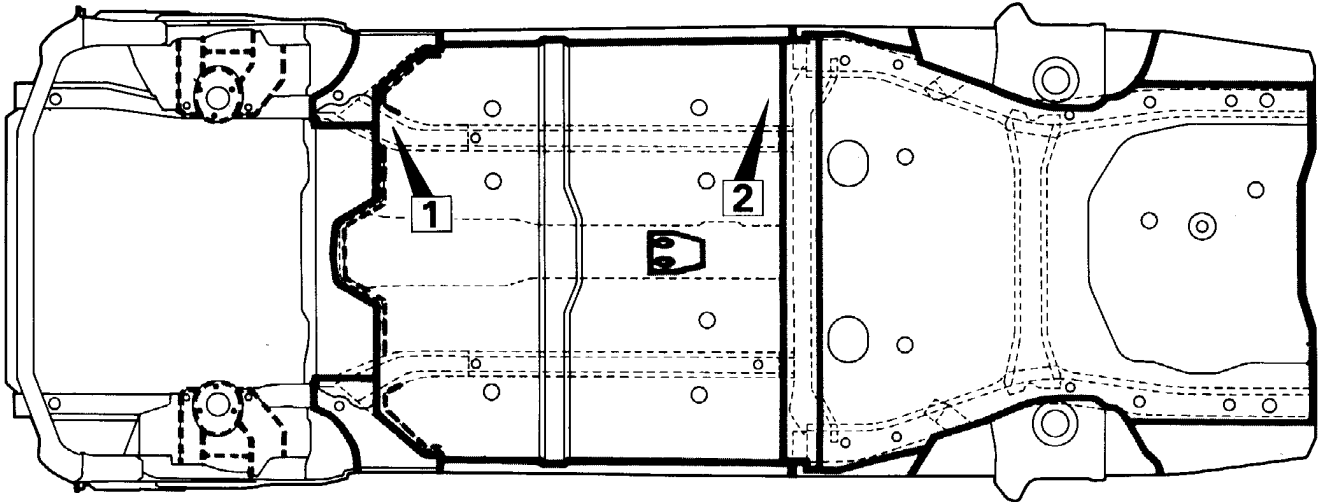

30X0089

UPPER BODY

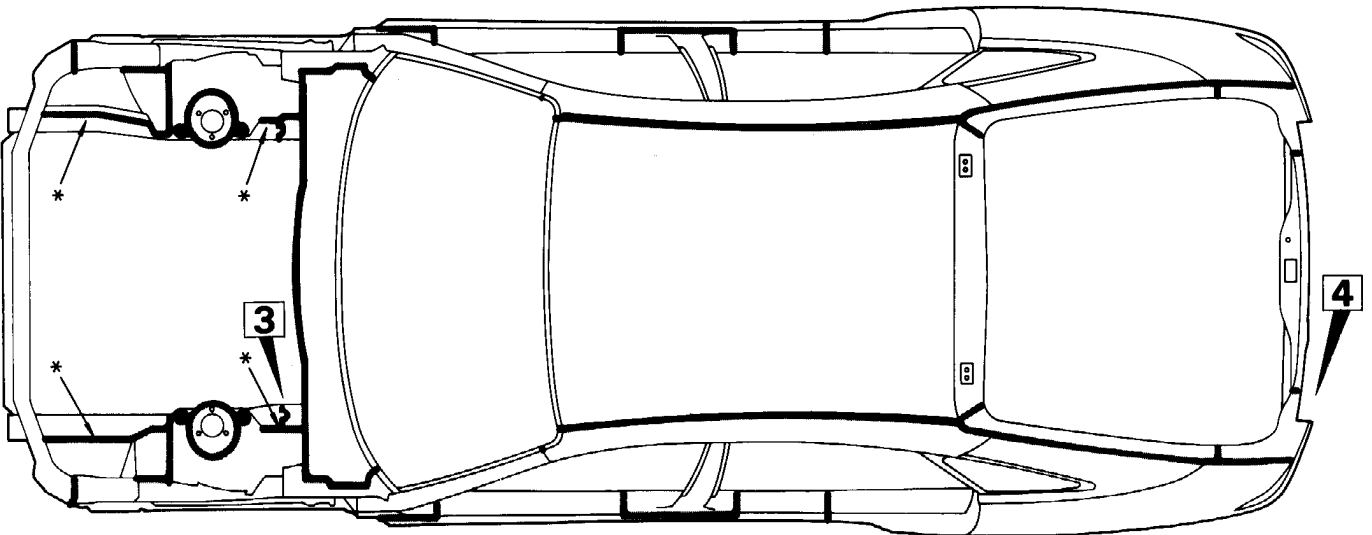

30X0096

SIDE BODY

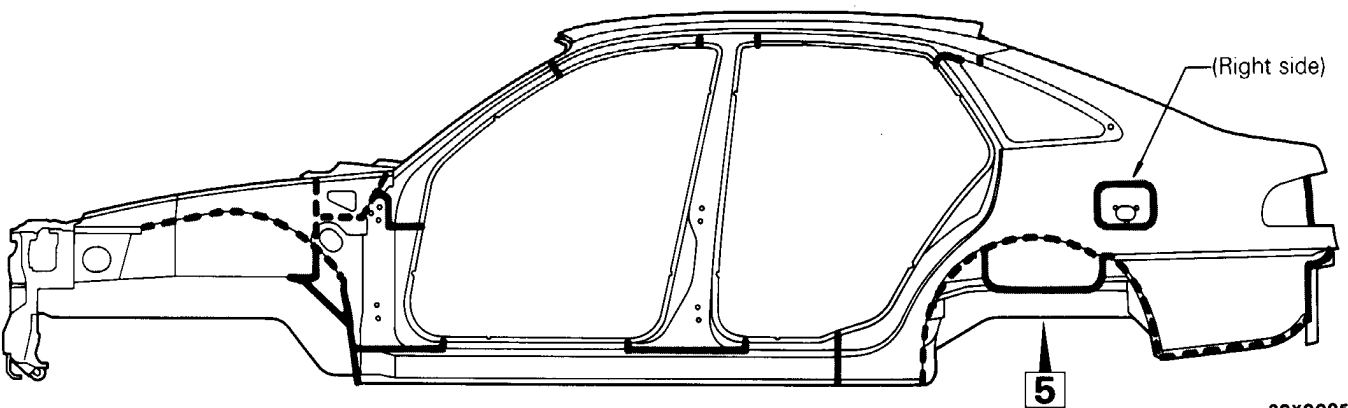

30X0095

NOTE
* : Vehicles for Europe

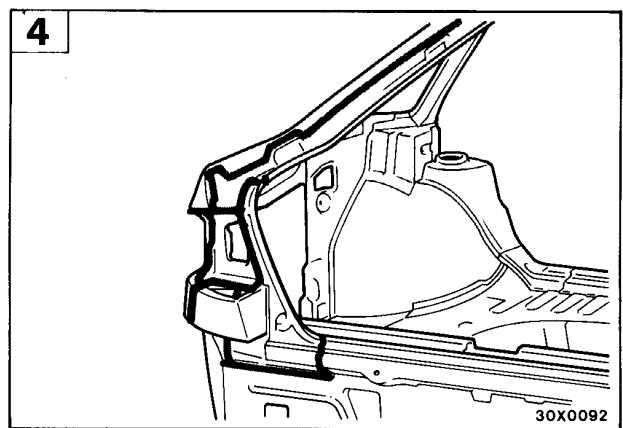
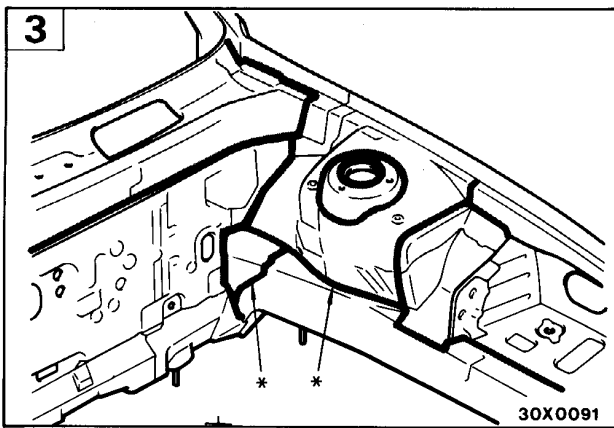
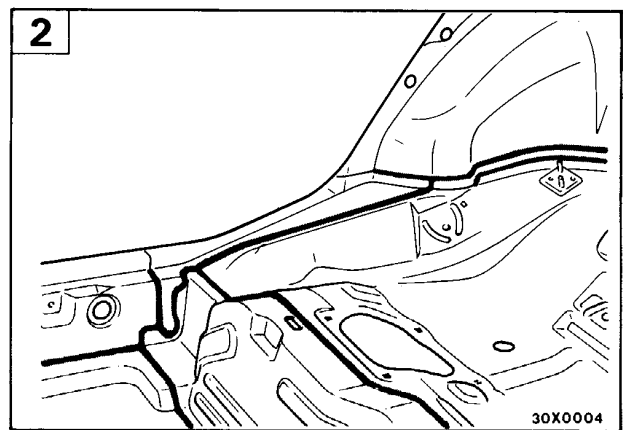
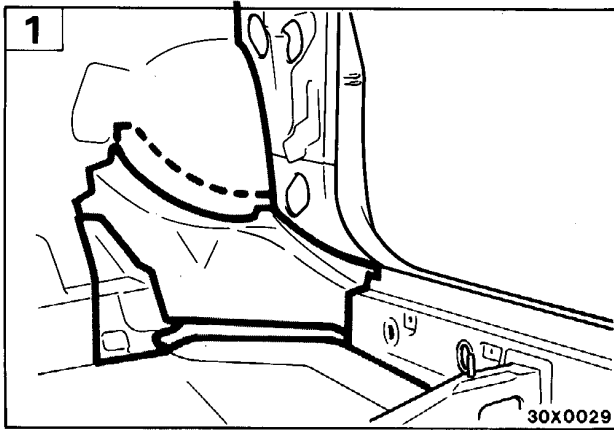

4

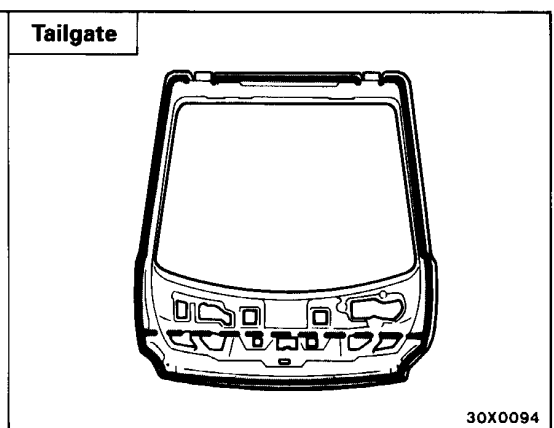
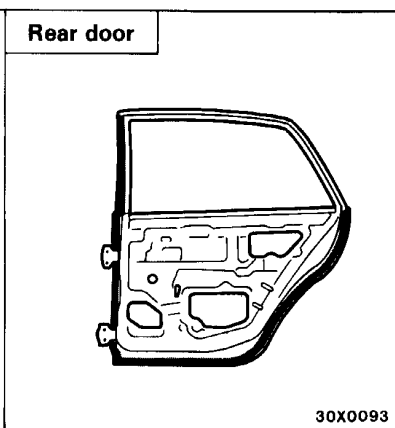
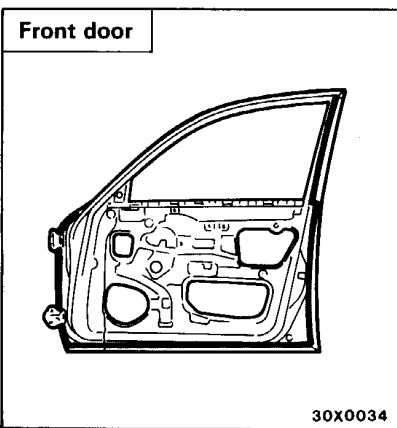
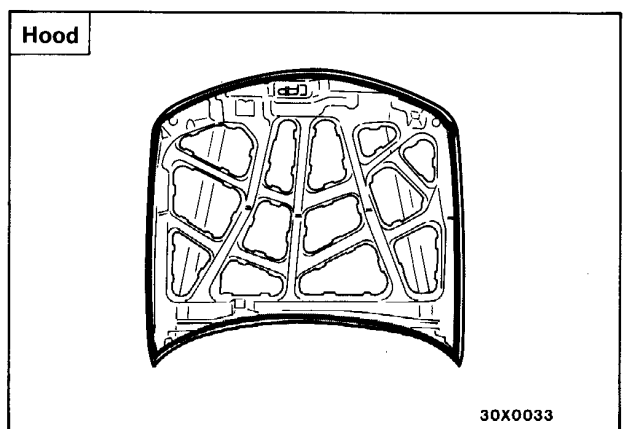
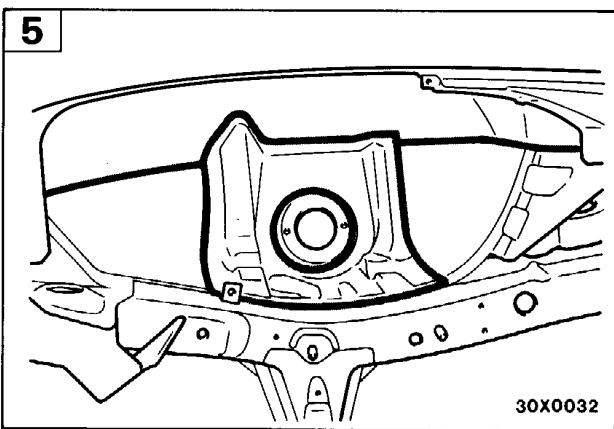

NOTE * : Vehicles for Europe

WAX INJECTION LOCATIONS

[Vehicles for Europe]

In order to provide greater corrosion resistance, wax injection has been performed for the lower areas of the vehicle, such as the frame, the side sill, and other panels which are a hollow-construction. If any of these panels are replaced, wax injection must be performed for the new parts.

Recommended wax:

- Tectyl 506, 506T or ML
- Waxoyl
- Dinitrol 3122 or 3654-1
- Mercasol 831-ML
- Terotex
- HV200PLUS or HV300

[SEDAN]

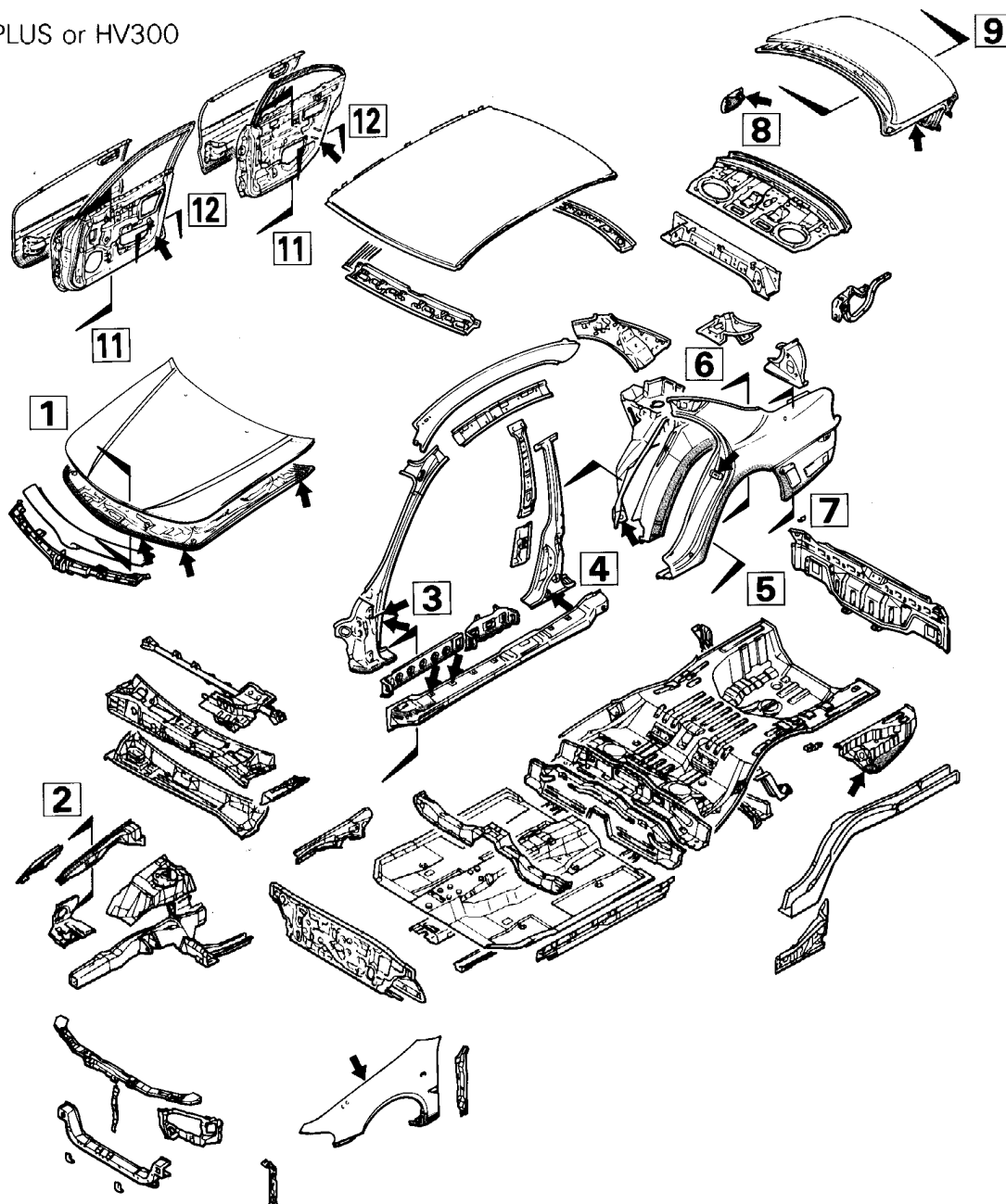

NOTES REGARDING WAX INJECTION WORK

- Be careful that the wax does not get onto other parts. Especially if wax is to be injected into the lower part of the center pillar and into the side sill, first remove the seat belt retractor and the door switch.
- For wax injection locations which have a rubber plug, do not forget to reinstall the rubber plug after the wax injection is completed.

NOTES

- (1) → : Nozzle insertion openings
 (2) For the numbers shown in the figure, refer to detailed illustrations with the same numbers on later pages.

[HATCHBACK]

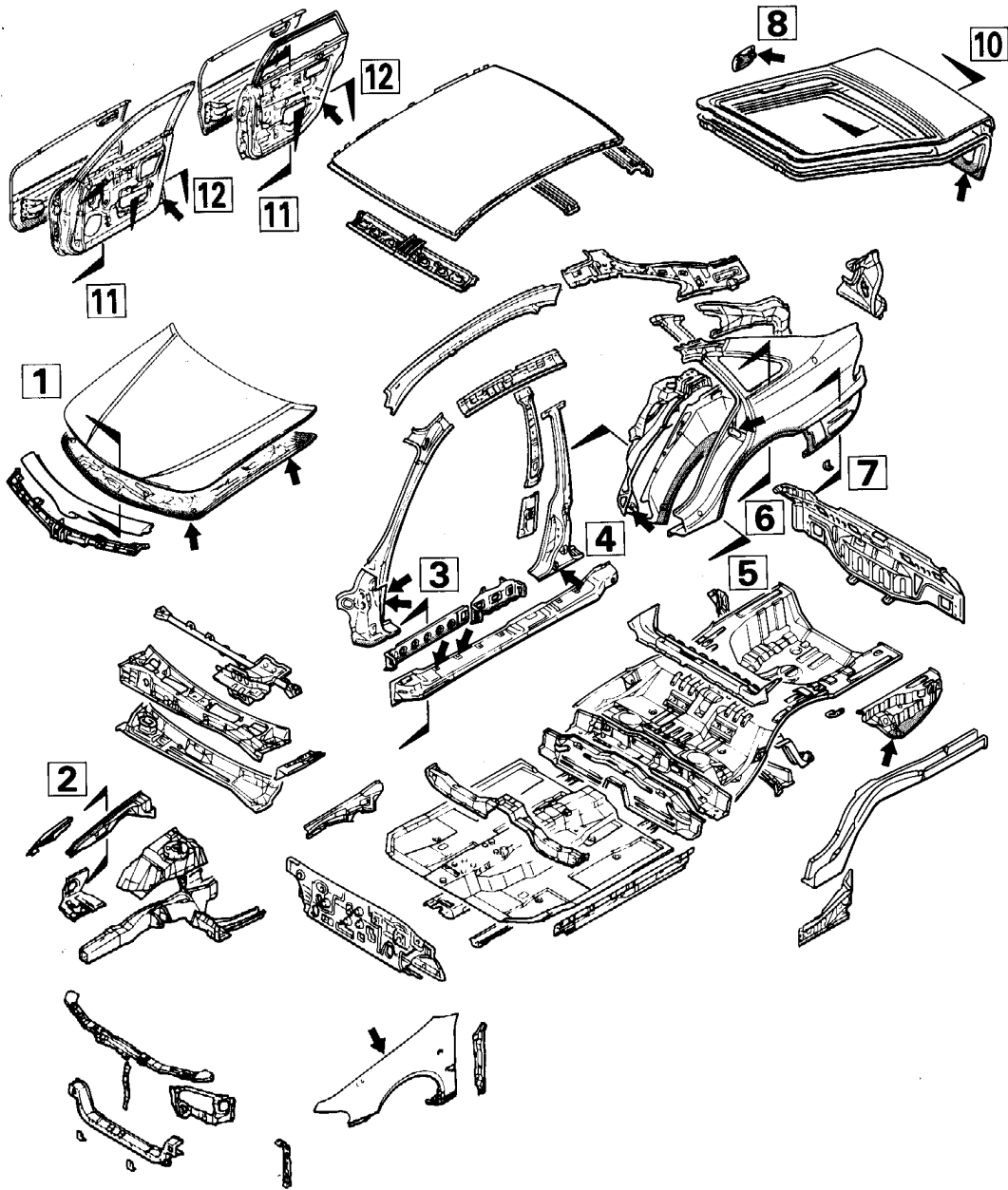

31X0180

NOTES

- (1) ➔ : Nozzle insertion openings
(2) For the numbers shown in the figure, refer to detailed illustrations with the same numbers on later pages.

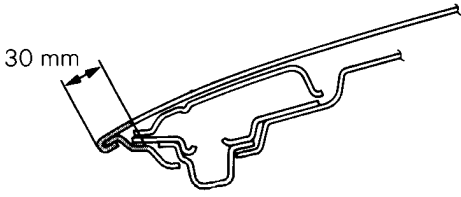
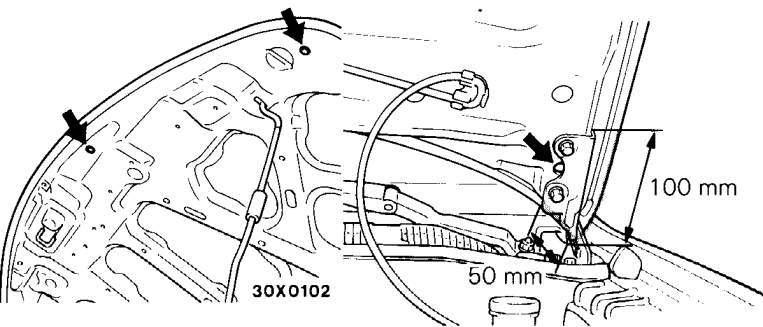
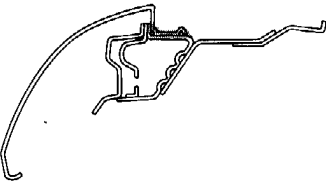
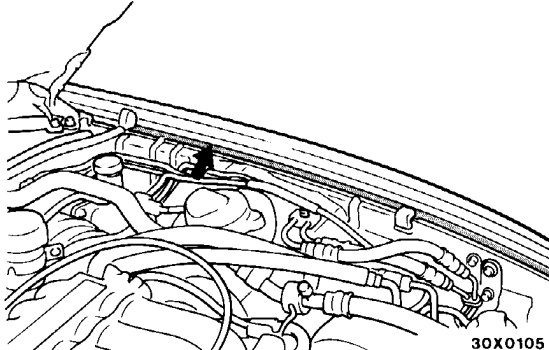
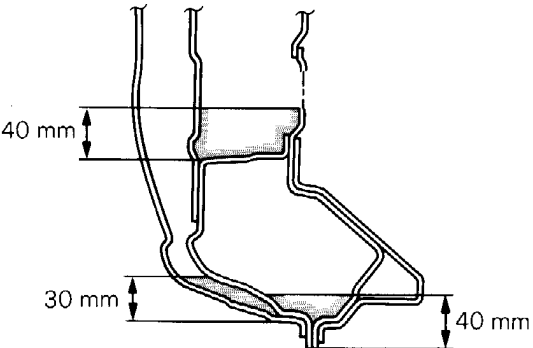
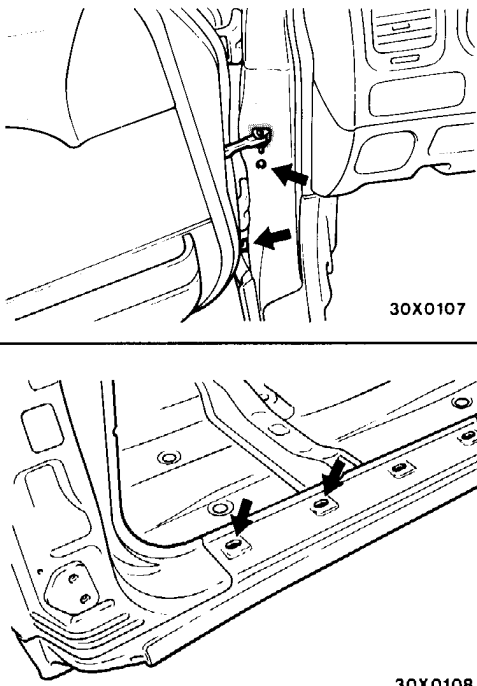
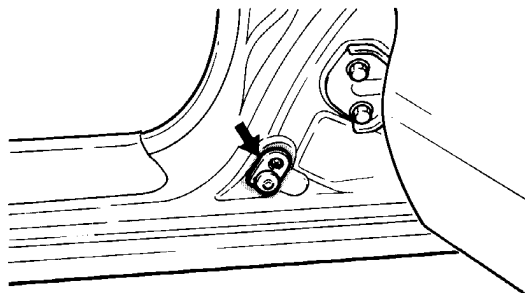
Application surfaces	← : Nozzle insertion openings
<p>1</p>  <p>30 mm</p> <p>30X0101</p>	 <p>30X0102</p> <p>50 mm</p> <p>100 mm</p> <p>30X0103</p>
<p>2</p>  <p>30X0104</p>	 <p>30X0105</p>
<p>3</p>  <p>40 mm</p> <p>30 mm</p> <p>40 mm</p> <p>30X0106</p>	 <p>30X0107</p> <p>30X0108</p>
<p>4</p>  <p>30X0109</p>	

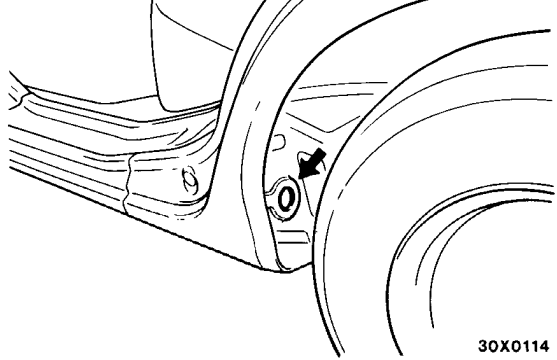
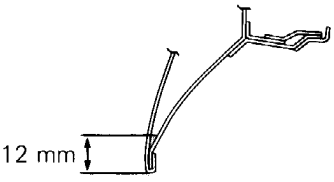
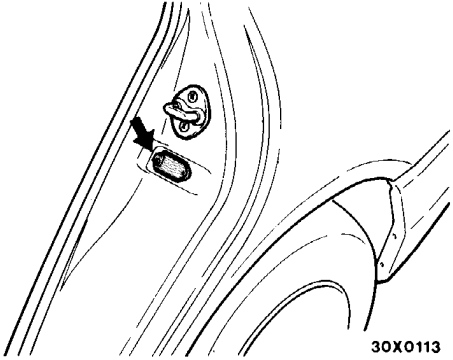
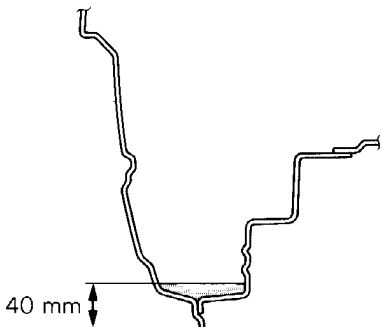
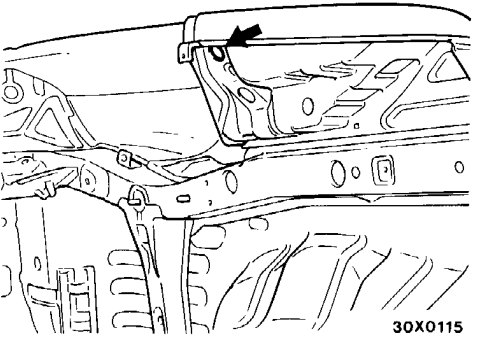
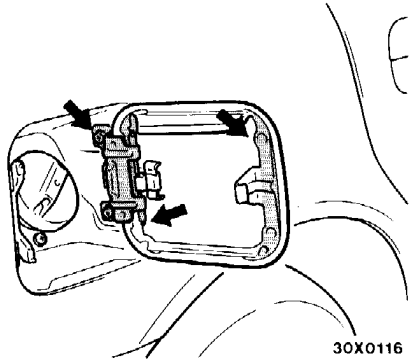
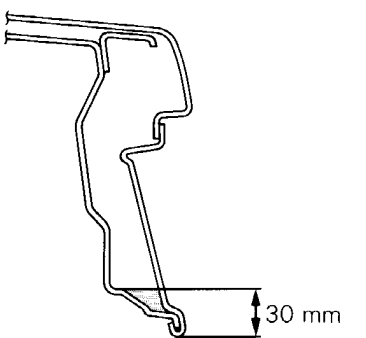
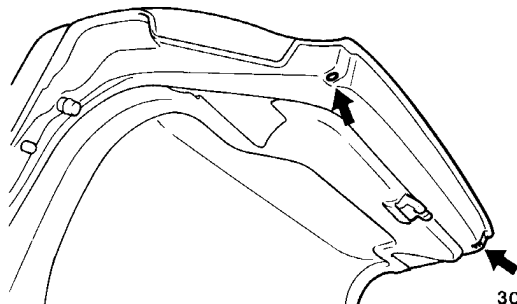
Application surfaces	← : Nozzle insertion openings
<p>5</p>  <p>30X0110</p>	 <p>30X0114</p>
<p>6</p>  <p>12 mm</p> <p>30X0111</p>	 <p>30X0113</p>
<p>7</p>  <p>40 mm</p> <p>30X0112</p>	 <p>30X0115</p>
<p>8</p>  <p>30X0116</p>	
<p>9 [SEDAN]</p>  <p>30 mm</p> <p>30X0117</p>	 <p>30X0118</p>

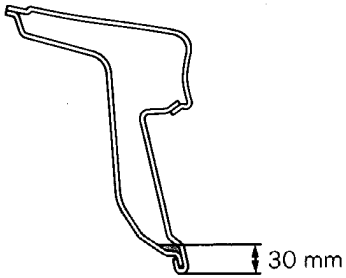
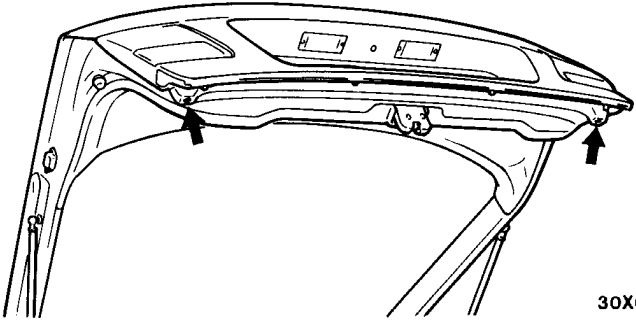
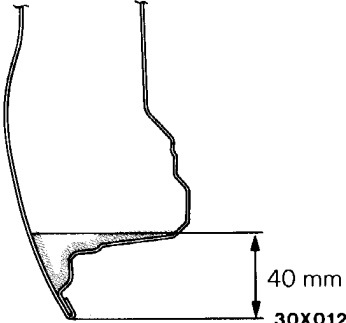
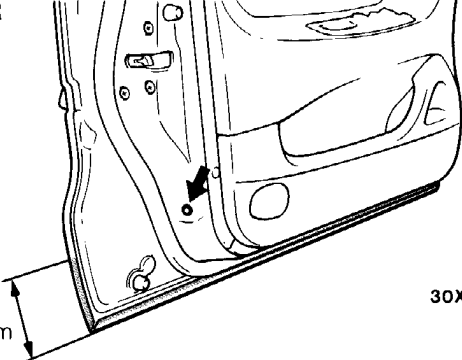
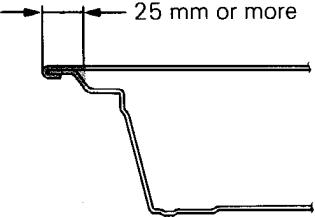
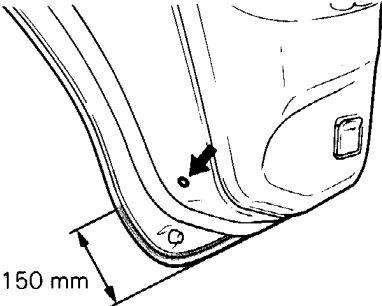
Application surfaces		← : Nozzle insertion openings	
<p>10 [HATCHBACK]</p>  <p>30 mm</p> <p>30X0119</p>	 <p>30X0122</p>		
<p>11</p>  <p>40 mm</p> <p>30X0120</p>	<p>FRONT DOOR</p>  <p>150 mm</p> <p>30X0123</p>		
<p>12</p>  <p>25 mm or more</p> <p>30X0121</p>	<p>REAR DOOR</p>  <p>150 mm</p> <p>30X0124</p>		

ANTICORROSION PRIMER LOCATIONS

An anticorrosion primer has been applied to the side sill outer panel; the lower edge of the front fender and the lower edge of the outer quarter panel for the purposes of corrosion prevention

and abrasion protection. If any of these panels are replaced, apply an anticorrosion primer between the under coat and the second coat, as shown in the following illustrations.

Primer name	Recommended primer	Coating thickness
Rocker panel primer	Glasurit FX89-7330 (polyester basis) or FT90-7103 (water basis) or equivalent	400 μ or more.

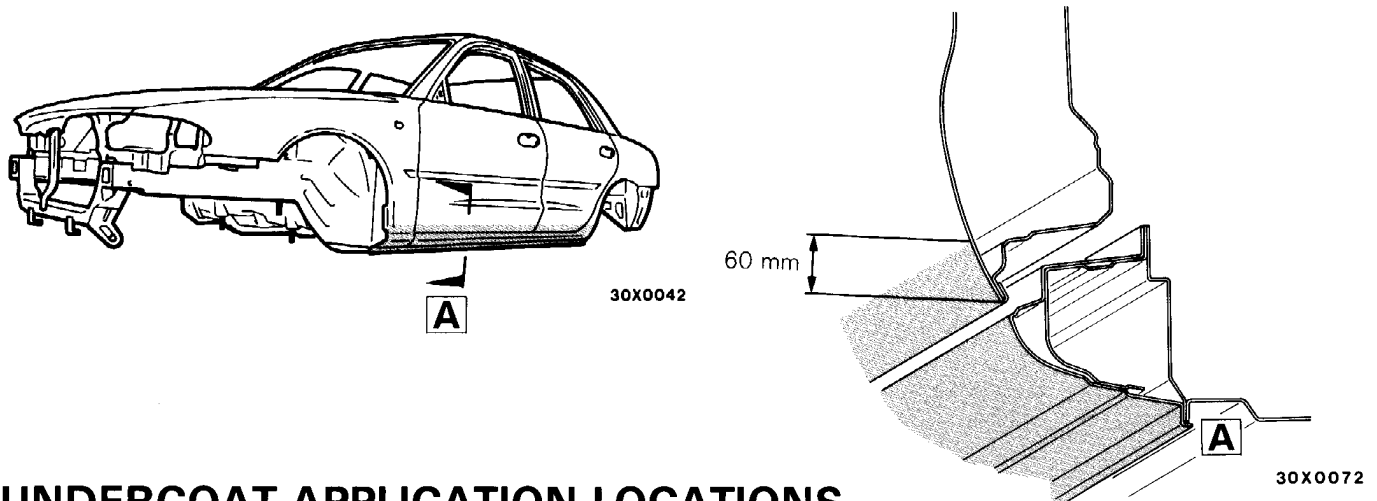

UNDERCOAT APPLICATION LOCATIONS

In order to provide rust, corrosion, chipping, and vibration resistance, an undercoat is applied to certain areas of the underbody. After completing body repairs, restore this undercoat if necessary.

<Vehicles for Europe>

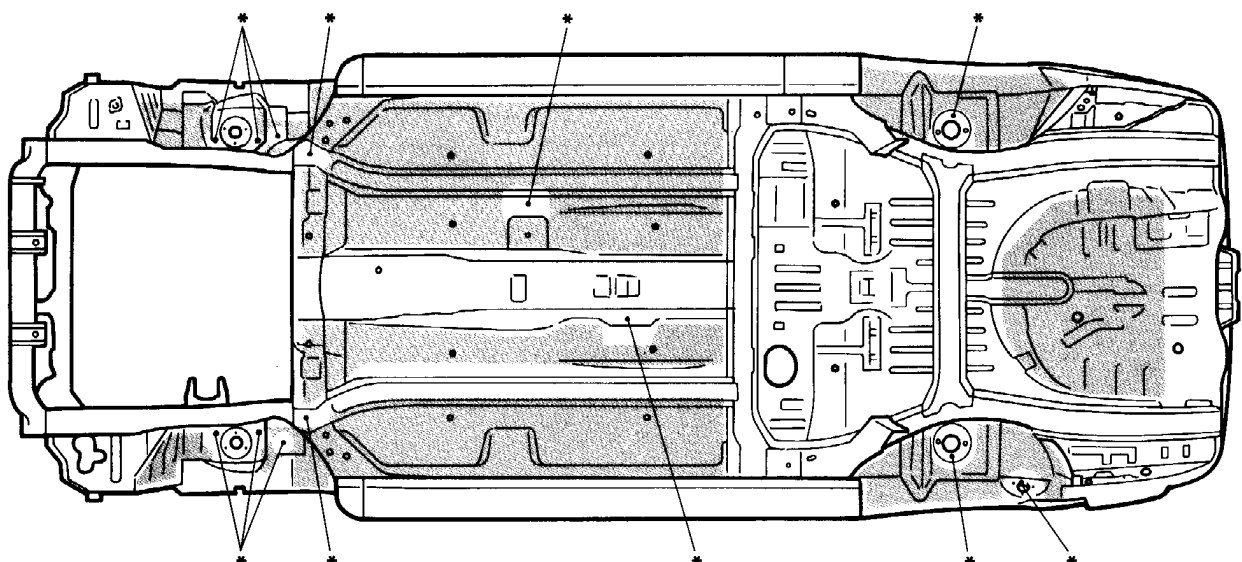

NOTE
 * Because parts are to be mounted in these locations mask the location before applying the undercoat.
 ■ : polyvinyl chloride base undercoating (film thickness of at least 0.8 mm)

30X0127

<Vehicles for General Export, GCC and Australia>

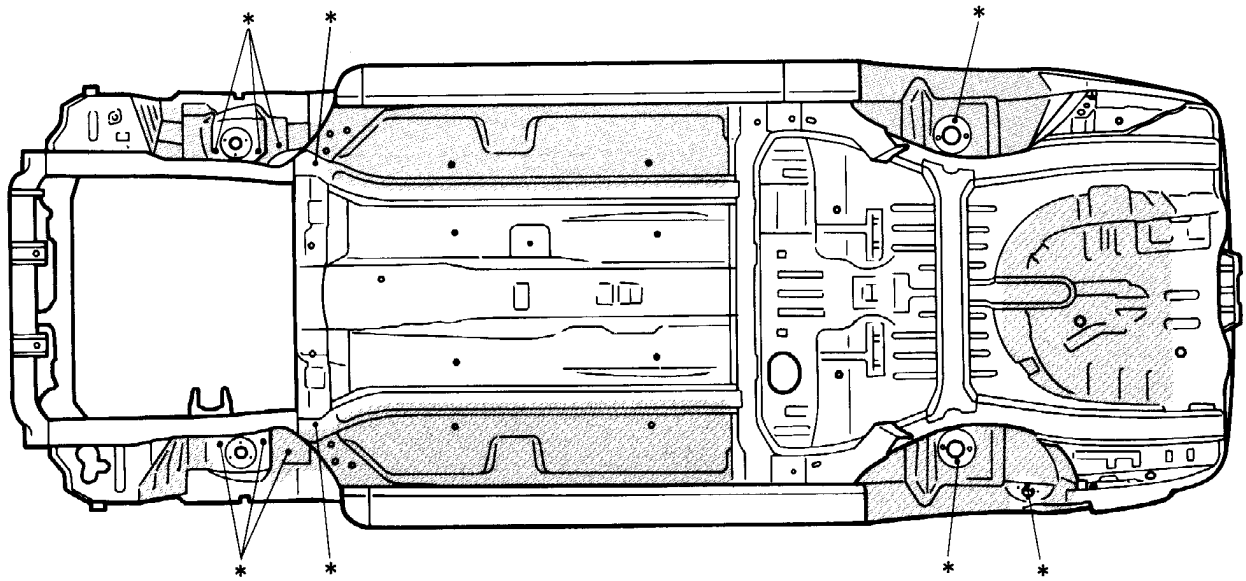

30X0043

NOTE

* Because parts are to be mounted in these locations, mask the location before applying the undercoat.

☐ : Polyvinyl chloride base undercoating
(film thickness of at least 0.6 mm)

UNDERBODY ANTICORROSION AGENT LOCATIONS

In order to provide a greater corrosion resistance, underbody corrosion prevention treatment should be performed after undercoat application. After completing body repairs, restore this underbody corrosion prevention treatment as indicated in the illustration if necessary.

Recommended agent:

- Tectyl 506T, 506 or S
- Waxoly
- Dinitrol 4954
- Terotex WAX
- Mercasol NON-DRIP

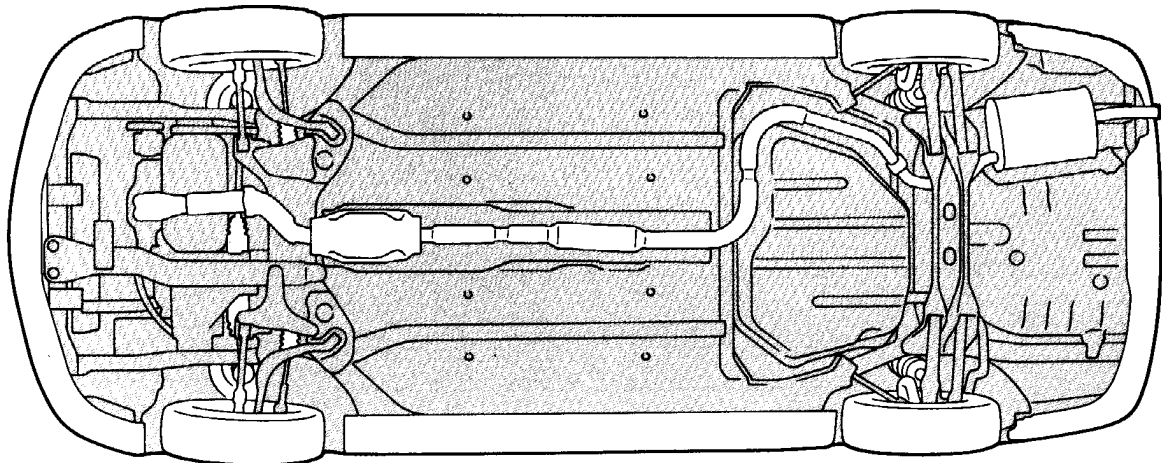

00X0002

NOTE

Take care not to permit the anticorrosion agent to come in contact with body painting, brake parts, exhaust pipes, bearing seals for rear axle and rubber parts (such as tyres and drive shaft boots).

☐ : 100 μ or more