

TRANSMISSION SERVICING - AT

1998 Mitsubishi Galant

1997-98 TRANSMISSION SERVICING
Mitsubishi Automatic Transmission

Diamante, Eclipse, Galant, Mirage, Montero, 3000GT

IDENTIFICATION

AUTOMATIC TRANSMISSION APPLICATIONS

Model	Transmission/Transaxle
Diamante	Model F4A51 Transaxle
Eclipse	
AWD	Model W4A33 Transaxle
FWD	
2.0L Non-Turbo	Model F4AC1 Transaxle
2.0L Turbo	Model F4A33 Transaxle
2.4L	Model F4A23 Transaxle
Galant	Model F4A23 Transaxle
Mirage	
1.5L	Model F4A41 Transaxle
1.8L	Model F4A42 Transaxle
Montero	
2WD	Model R4AW3 Transmission
4WD	Model V4AW3 Transmission
3000GT	Model F4A33 Transaxle

LUBRICATION

SERVICE INTERVALS

Transaxle/Transmission

Check fluid level every 12 months or 15,000 miles. Change fluid and filter every 30,000 miles. If vehicle is operated under severe conditions, change fluid more often. If severe darkening of fluid and strong odor are noted, bands should also be adjusted.

Transfer Case

On 4WD and AWD models, change transfer case fluid every 30,000 miles.

CHECKING FLUID LEVEL

Transaxle/Transmission

1) Park vehicle on level area. Ensure oil is at normal operating temperature, parking brake is engaged, and engine is at idle. Move gear selector through each position, stopping briefly at each selection.

2) Place gear selector in Neutral, and clean area around dipstick tube. Ensure fluid level is between lower and upper marks, but never over upper mark, in HOT range. Add or drain fluid if necessary.

CAUTION: If severe darkening of fluid and strong odor are noted, change fluid and filter, and adjust bands.

Transfer Case (All Others)

Lubricant level should be to bottom of fill hole on side of transfer case.

RECOMMENDED FLUID

Transaxle/Transmission

Except Montero, use Diamond ATF SP-II. On Montero, use Dexron-II ATF.

Transfer Cases

Use SAE 75W-85 gear oil with API GL-4 rating or higher.

FLUID CAPACITIES

TRANSAXLE/TRANSMISSION REFILL CAPACITIES

Application	Qts. (L)
Diamante	9.0 (8.5)
Eclipse	
2.0L Non-Turbo	9.1 (8.6)
2.0L Turbo	7.1 (6.7)
2.4L	6.4 (6.1)
Galant	6.3 (6.0)
Mirage	8.2 (7.8)
Montero	10.4 (9.8)
3000GT	7.9 (7.5)

TRANSFER CASE REFILL CAPACITIES

Application	Pts. (L)
Eclipse AWD	1.0 (.5)
Montero	5.3 (2.5)
Montero Sport	4.9 (2.3)
3000GT6 (.3)

DRAINING & REFILLING

NOTE: Although manufacturer recommends changing only fluid, the oil filter/screen may also require replacement. If replacing oil filter/screen, note length and location of all bolts.

Transaxle (Except Montero)

1) Remove drain plug(s), and drain fluid. Some models may contain a drain plug located in housing below axle shaft, in oil pan. Remove oil pan. Remove oil filter/screen if necessary.

2) If oil filter/screen is replaced, tighten bolts to specification. See TORQUE SPECIFICATIONS. Clean oil pan, replace gasket, and install oil pan. Tighten oil pan bolts and drain plug to specification. See TORQUE SPECIFICATIONS. Ensure dipstick hole area is clean. Fill transmission with Diamond ATF SP-II, through filler tube, until COLD level is reached on dipstick.

3) Start engine and allow to idle for 2 minutes. Shift transaxle to each position, ending in Neutral. Add sufficient fluid to reach lower mark. After reaching normal operating temperature, fluid should be between upper and lower marks of HOT range on dipstick.

Transmission (Montero)

1) Remove drain plug (if equipped) from transmission pan, and allow fluid to drain. On models without drain plug, oil pan must be

removed to drain fluid. Remove oil filter/screen if necessary.

2) If oil filter/screen is replaced, tighten bolts to specification. See TORQUE SPECIFICATIONS. Clean oil pan, replace gasket, and install oil pan. Tighten oil pan bolts and drain plug to specification. See TORQUE SPECIFICATIONS. Ensure dipstick hole area is clean. Fill transmission with Dexron-II ATF, through filler tube, until COLD level is reached on dipstick. Start engine, and allow to idle for 2 minutes.

3) Shift transmission into each position, ending in Neutral. Check fluid level with engine running at idle. If necessary, add sufficient fluid to bring level to lower mark of dipstick. Recheck fluid level after transmission is at normal operating temperature.

Transfer Case

Drain plug is located on bottom of transfer case. Change drain plug gasket whenever fluid is changed. Lubricant level should be at bottom of fill hole on side of transfer case.

ADJUSTMENTS

KICKDOWN SERVO

Eclipse, Galant & 3000 GT

1) Remove all dirt and grease around kickdown servo switch. Remove snap ring and kickdown servo switch.

2) To prevent servo piston from turning, install Adapter (MD998915) and Kickdown Servo Wrench (MD998918) so tab of wrench engages with notch of piston. See Fig. 1.

CAUTION: DO NOT push servo piston inward while installing adapter and servo wrench. Install adapter in brake pressure port by hand ONLY. DO NOT use wrench to tighten adapter.

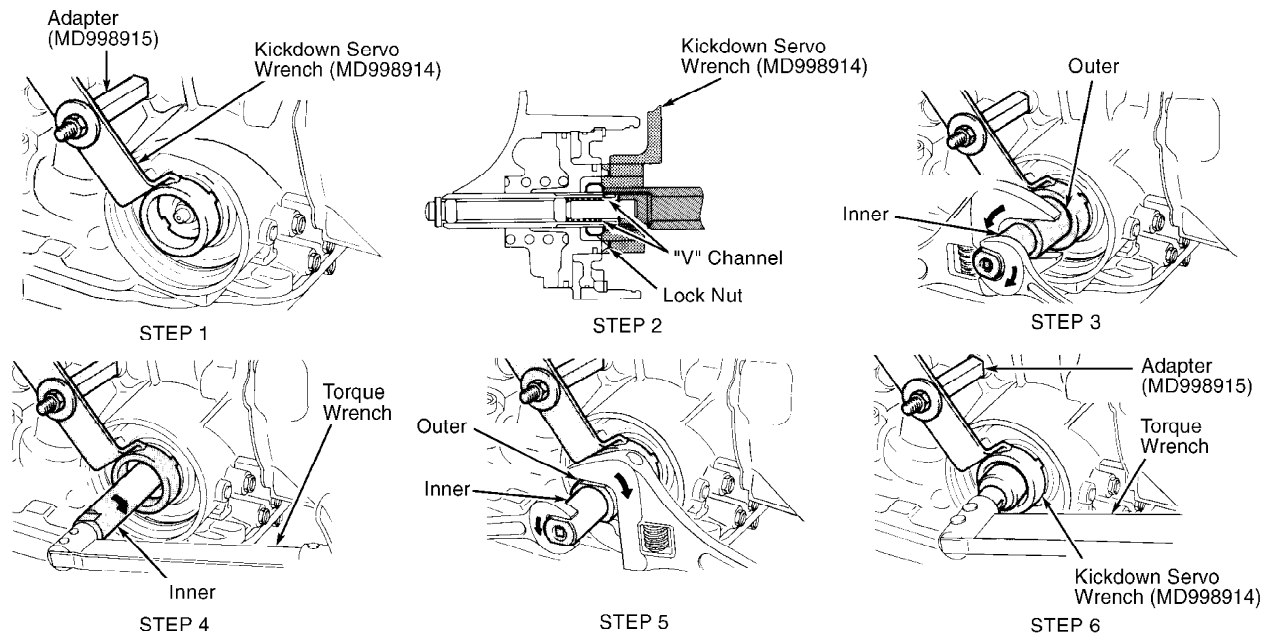

90H02446
Fig. 1: Adjusting Kickdown Servo (Eclipse, Galant & 3000 GT)
Courtesy of Mitsubishi Motor Sales of America.

3) Loosen lock nut to "V" channel of adjuster rod. Tighten inner section of Kickdown Service Adjustment Assembly (MD998916) until

it contacts lock nut. See Fig. 1.

4) Install outer section of kickdown service adjustment assembly on lock nut. Rotate outer section to left and inner section to right to contact lock nut with inner section.

5) Using an INCH-lb. torque wrench on inner section, tighten inner section to 89 INCH lbs. (10 N.m), and then loosen inner section. Tighten inner section to 44 INCH lbs. (5 N.m).

CAUTION: Before tightening lock nut with torque wrench, tighten it by hand until it contacts piston. If torque wrench is used initially, lock nut and adjustment rod may rotate together.

6) Back off outer section 2-2 1/4 turns. Rotate outer section to right and inner section to left until inner section is free of lock nut. Tighten lock nut by hand until it contacts piston. Using torque wrench, tighten lock nut to 18-23 ft. lbs. (25-32 N.m).

7) Remove adapter and kickdown servo wrench. Install new "O" ring in groove around switch. Install switch and snap ring.

SHIFT LINKAGE

Except Montero

1) Ensure shift and transaxle/transmission levers are both in Neutral position. Loosen adjusting nut on control cable. See Fig. 2. Loosen park/neutral position switch body bolts. Rotate park/neutral position switch until hole in end of transmission manual control lever is aligned with hole (cross section A-A) in flange of park/neutral position switch body. Tighten park/neutral position switch body bolts. Ensure holes in park/neutral position switch flange and transmission manual control lever stay aligned.

2) Gently pull control cable from dust cover. Make sure shift lever is still in Neutral. Tighten adjusting nut. Check transaxle/transmission operation through all ranges. Readjust control cable if necessary.

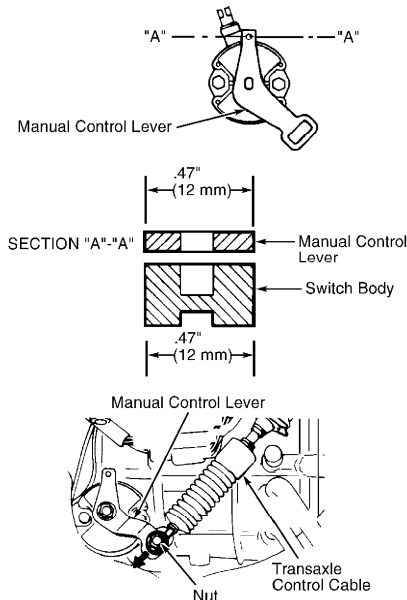

91102927
Fig. 2: Adjusting Shift Cable (Except Montero)
Courtesy of Mitsubishi Motor Sales of America.

Montero

Ensure shift and transmission levers are both in Neutral

position. Loosen adjusting nut on control cable. See Fig. 3. Gently pull control cable from dust cover. Make sure shift lever is still in Neutral. Tighten adjusting nut. Check transmission operation through all ranges. Readjust control cable if necessary.

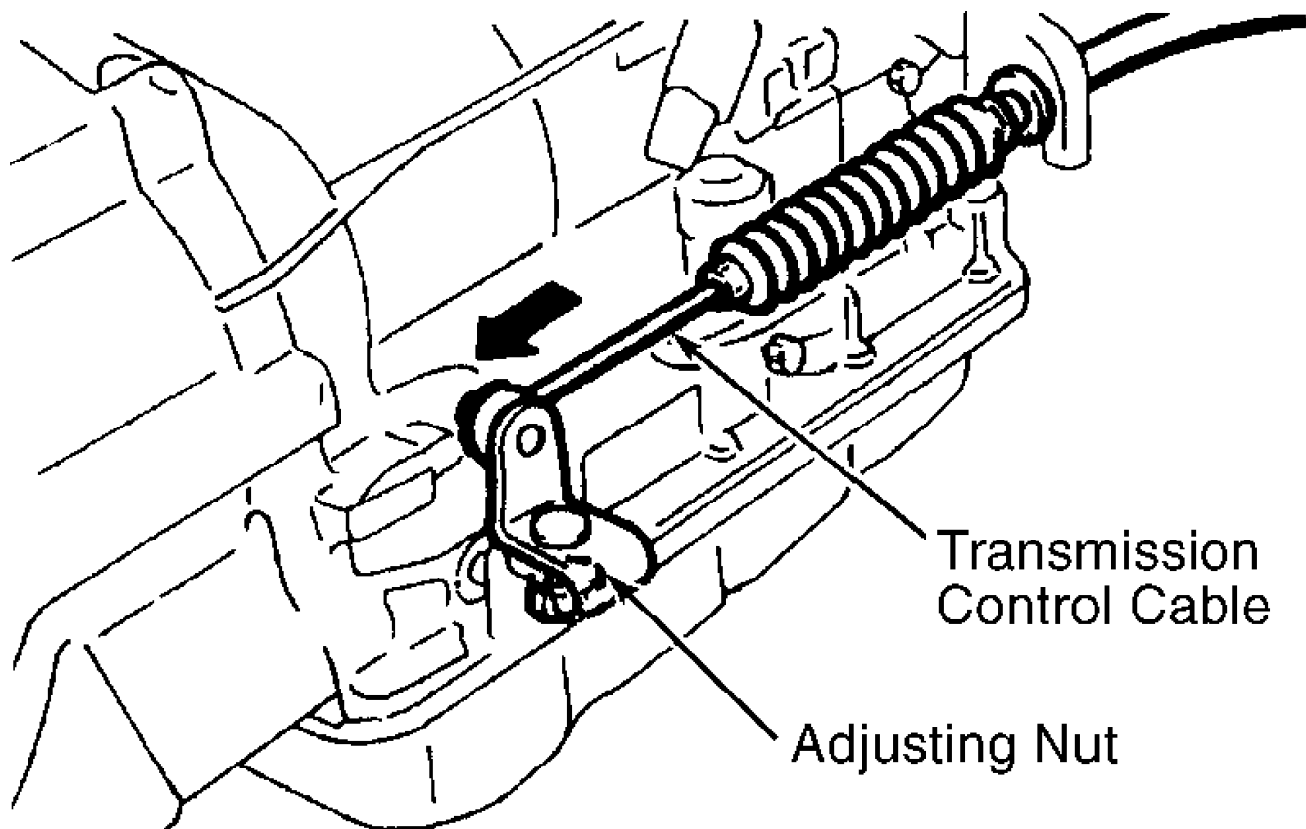

96A18580

Fig. 3: Adjusting Shift Linkage (Montero)
 Courtesy of Mitsubishi Motor Sales of America.

SHIFT LEVER SLEEVE

Eclipse & Galant

To adjust shift lever sleeve, remove shift handle on top of shift lever. With lever in Neutral, turn sleeve so distance between sleeve and lever end is within specification. See SHIFT LEVER SLEEVE CLEARANCE SPECIFICATION table. See Fig. 4. Ensure beveled side of sleeve faces toward push button (if equipped).

SHIFT LEVER SLEEVE CLEARANCE SPECIFICATION

Application	Clearance In. (mm)
Eclipse & Galant62-.64 (15.7-16.3)

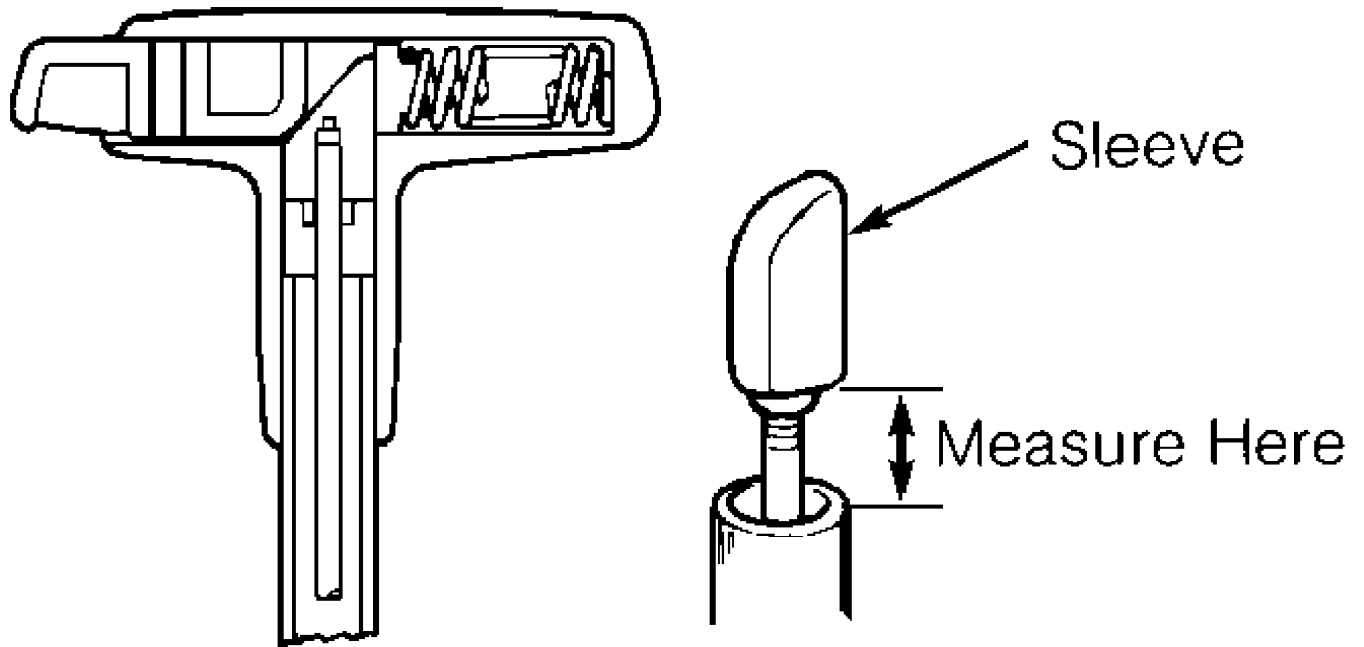

96H19247

Fig. 4: Adjusting Shift Lever Sleeve (Eclipse & Galant)
 Courtesy of Mitsubishi Motor Sales of America.

NEUTRAL SAFETY SWITCH

All Models

Neutral safety switch is adjusted along with shift linkage.

See SHIFT LINKAGE.

TORQUE SPECIFICATIONS

TORQUE SPECIFICATIONS

Application	Ft. Lbs. (N.m)
Drain Plug	
Transaxle/Transmission	
Except Montero	22-25 (30-35)
Montero	13-17 (18-24)
Transfer Case	24 (32)
Rear Cover	17 (23)
	INCH Lbs. (N.m)
Kickdown Servo Lock Nut	121 (29)
Oil Filter/Screen Bolt	
Except Montero	48-60 (5.4-6.8)
Montero	61 (6.9)
Oil Pan Bolt	
Except Montero	84-108 (9.5-12.2)
Montero	69 (7.8)
Park/Neutral Switch Mounting Bolt (Except Montero)	97 (11)
Park/Neutral Switch Mounting Bolt (Montero)	115 (13)
Transmission Control Cable Adjusting Nut	115 (13)
Valve Body Cover	97 (11)
