

# WHEEL ALIGNMENT SPECIFICATIONS & PROCEDURES

## 1998 Mitsubishi Galant

1997-98 WHEEL ALIGNMENT  
Mitsubishi - Specifications & Procedures

Diamante, Eclipse, Galant, Mirage,  
Montero, Montero Sport, 3000GT

### RIDING HEIGHT ADJUSTMENT

NOTE: Prior to performing wheel alignment, perform preliminary visual and mechanical inspection of wheels, tires and suspension components. See PRE-ALIGNMENT INSTRUCTIONS in WHEEL ALIGNMENT THEORY & OPERATION article in GENERAL INFORMATION.

NOTE: On vehicles with electronic chassis controls, ensure all systems are functional before attempting to adjust riding height or wheel alignment. See appropriate ELECTRONIC article under SUSPENSION.

1) Before adjusting wheel alignment, visually inspect vehicle. Remove any heavy items from passenger and luggage compartments. Ensure tires are properly inflated and vehicle is level. Bounce vehicle several times, and allow suspension to settle.

2) Check riding height from front to rear and from side to side. If riding height is not as specified on Montero and Montero Sport, adjust torsion bar anchor arm nut until correct height is obtained. See RIDING HEIGHT SPECIFICATIONS (FRONT) table. On all other models, riding height for left and right sides of vehicle should not vary more than 1.0" (25.4 mm). If riding height is not within specification, check and repair suspension before adjusting alignment.

#### RIDING HEIGHT SPECIFICATIONS (FRONT)

Application	(1) In. (mm)
Montero .....	.83-.91 (21.0-23.0)
Montero Sport .....	2.7 (68)

(1) - Distance between lower control bumper stop and bracket.  
See Fig. 1.

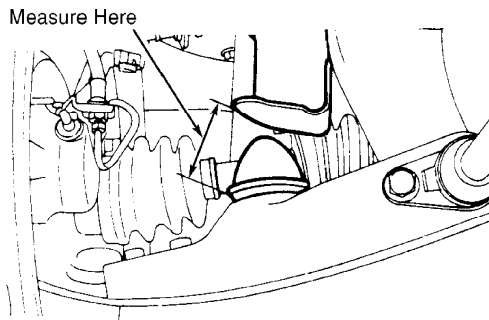

92E00228

Fig. 1: Measuring Riding Height (Montero & Montero Sport)  
Courtesy of Mitsubishi Motor Sales of America.

### JACKING & HOISTING

**\* PLEASE READ FIRST \***

NOTE: Following illustrations are given to provide reference points only. Illustrations do not represent exact structure of vehicle frame, underbody or body outline.

**EMERGENCY JACKING**

Points on outline of body were designated to be used specifically with vehicle jack. See Fig. 2. If using floor jack or hoist at these points, use extreme care to avoid damaging outer body shell.

**FLOOR JACK & HOIST**

Following illustrations indicate points for jacking and hoisting vehicle. These points are indicated by shaded areas on frame and underbody. See Figs. 3-5.

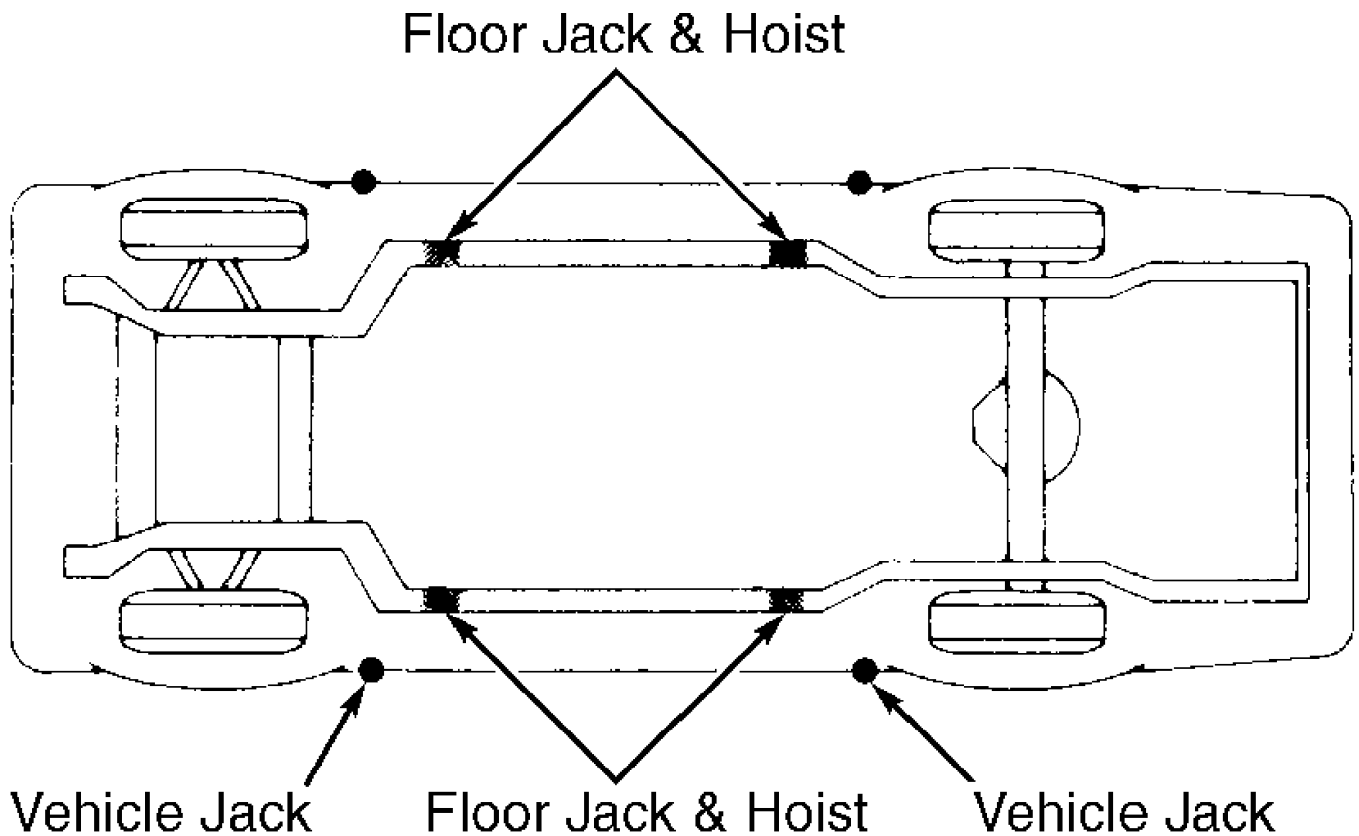

90C00325

Fig. 2: Identifying Jacking & Hoisting Points (Typical)

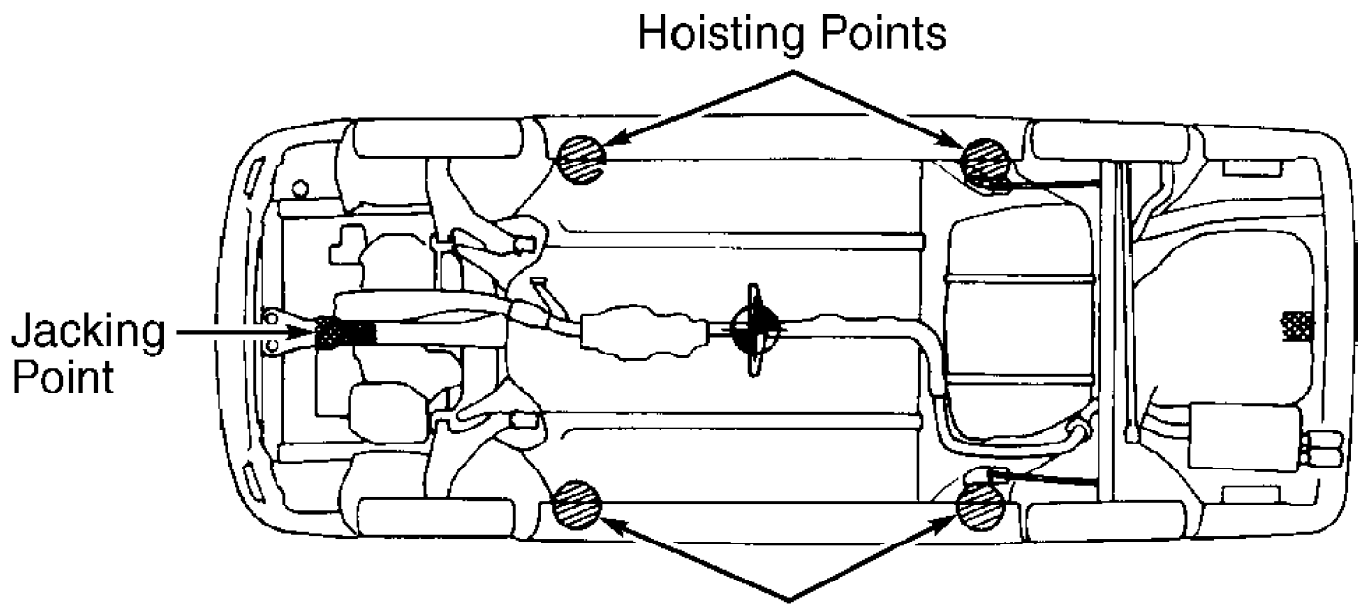

Hoisting Points  
2WD

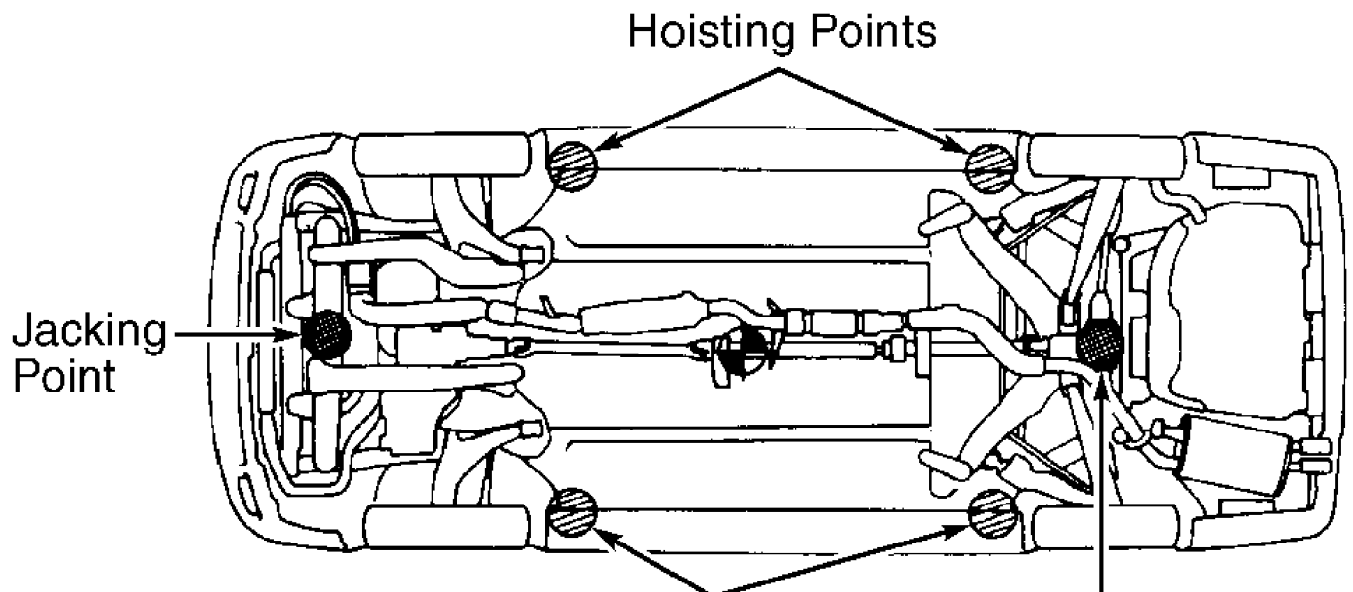

Hoisting Points  
Jacking Point  
4WD

91B01929

Fig. 3: Identifying Jacking & Hoisting Points (Except Montero, Montero Sport & 3000GT)  
Courtesy of Mitsubishi Motor Sales of America.

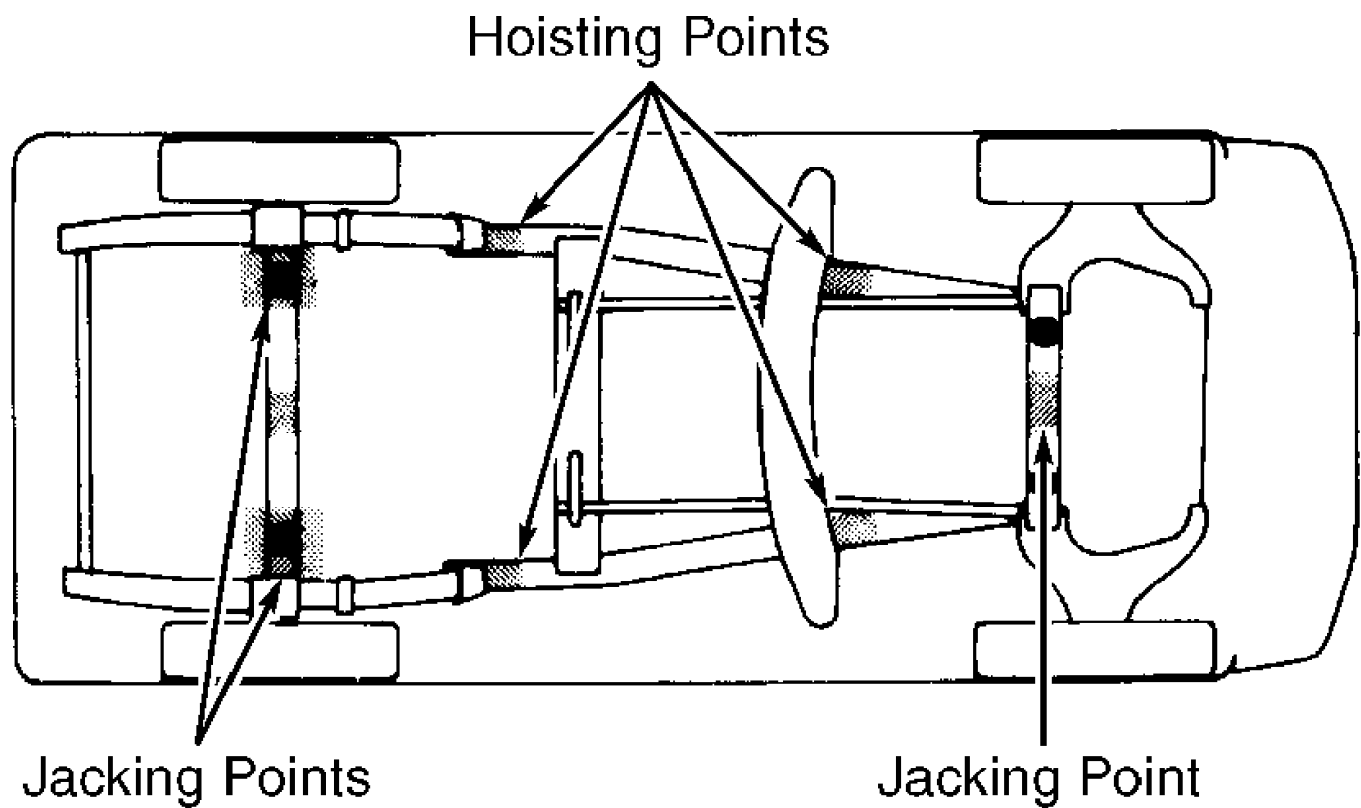

90G00329

Fig. 4: Identifying Jacking & Hoisting Points (Montero & Montero Sport)  
 Courtesy of Mitsubishi Motor Sales of America.

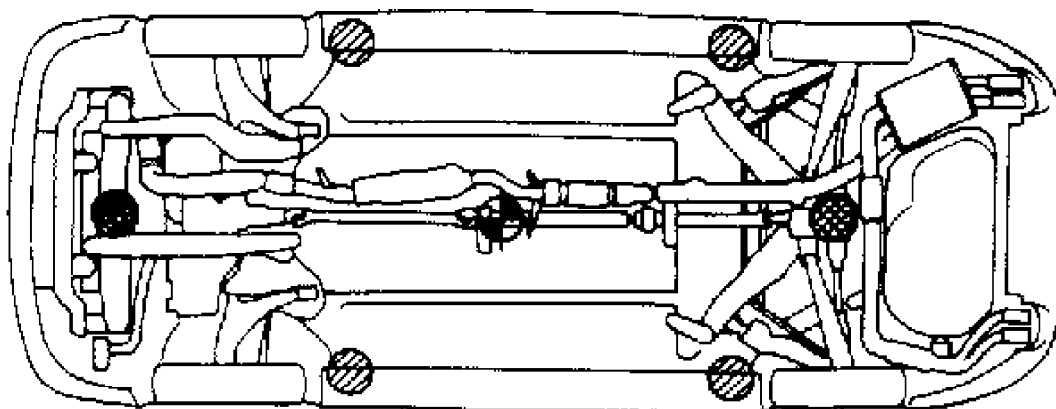

93J82064

Fig. 5: Identifying Jacking & Hoisting Points (3000GT AWD Shown; FWD Is Similar)  
 Courtesy of Mitsubishi Motor Sales of America.

## WHEEL ALIGNMENT PROCEDURES

### CAMBER ADJUSTMENT

Except Montero, Montero Sport & 3000GT

Camber is preset and cannot be adjusted. Check camber. See appropriate table under WHEEL ALIGNMENT SPECIFICATIONS. If camber is not within specification, replace damaged or bent parts.

Montero & Montero Sport

1) Check camber. See appropriate table under WHEEL ALIGNMENT SPECIFICATIONS. If camber is not within specification, remove shock absorber mounting nut and lock nut.

CAUTION: Difference in shim thickness between front and rear must not exceed 0.16" (4.0 mm). DO NOT use more than 3 shims at one location.

2) Compress shock absorber, and loosen upper arm mounting bolts and nuts. Adjust camber by increasing or decreasing shims between upper arm shaft and crossmember. See Fig. 6.

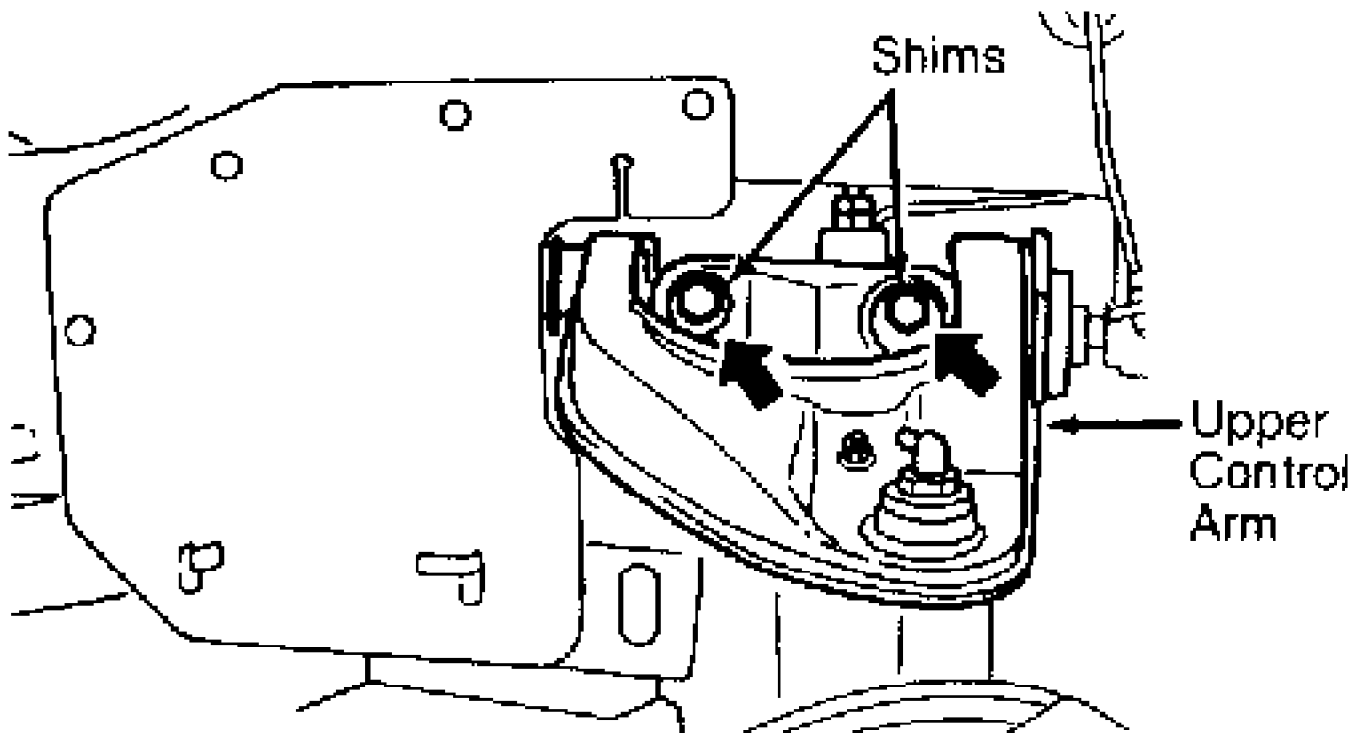
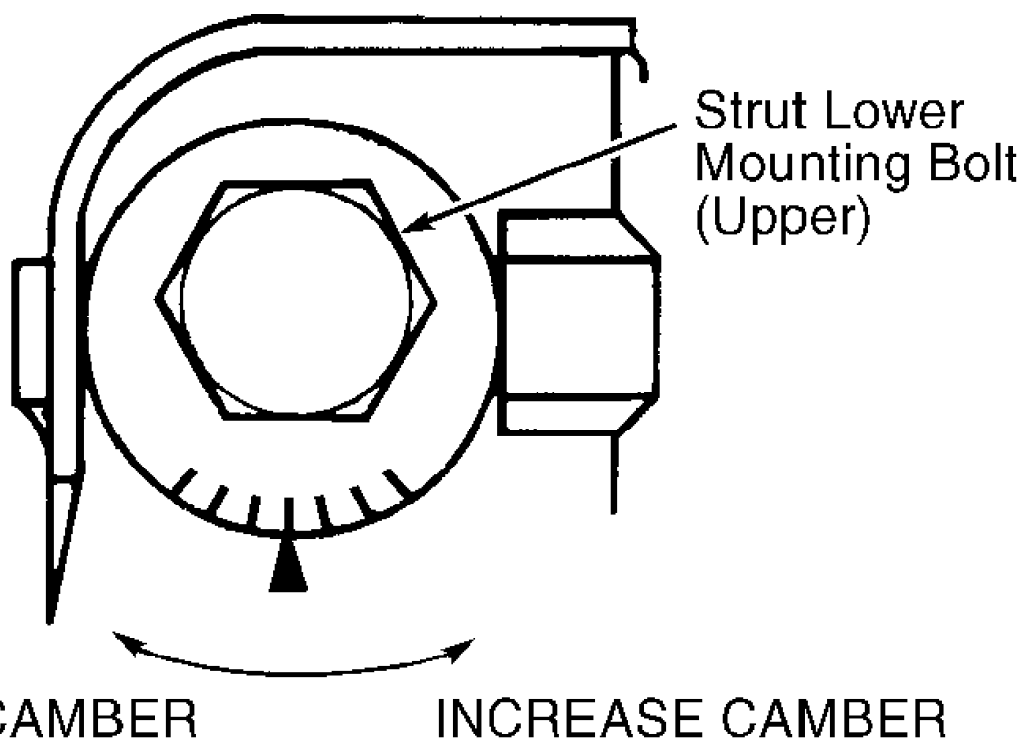

Fig. 6: Adjusting Camber & Caster (Montero Sport Shown; Montero Is Similar)

Courtesy of Mitsubishi Motor Sales of America.

3000GT

Check camber. See WHEEL ALIGNMENT SPECIFICATIONS (3000GT) table. If camber is not within specification, loosen eccentric cam nut. Rotate eccentric cam bolt to obtain correct camber. See Fig. 7. Each marking represents a change of .12-.25 degree of camber.



92100230

Fig. 7: Adjusting Camber (3000GT)  
 Courtesy of Mitsubishi Motor Sales of America.

### CASTER ADJUSTMENT

Except Montero & Montero Sport

Check caster. See appropriate table under WHEEL ALIGNMENT SPECIFICATIONS. If caster is not within specification, replace damaged or bent parts.

Montero & Montero Sport

1) Check caster. See appropriate table under WHEEL ALIGNMENT SPECIFICATIONS. If caster is not within specification, remove shock absorber mounting nut and lock nut.

CAUTION: Difference in shim thickness between front and rear must not exceed .16" (4.0 mm). DO NOT use more than 3 shims at one location.

2) Compress shock absorber, and loosen upper arm mounting bolts and nuts. Adjust caster by increasing or decreasing shims between upper arm shaft and crossmember. See Fig. 6.

### TOE-IN ADJUSTMENT

Front

Check front toe-in. See appropriate table under WHEEL ALIGNMENT SPECIFICATIONS. If front toe-in is not within specification, remove clips. Turn tie rods or turnbuckles same amount, but in opposite directions. Recheck front toe-in.

Rear (Montero & Montero Sport)

Check rear toe-in. See appropriate table under

WHEEL ALIGNMENT SPECIFICATIONS. If rear toe-in is not within specification, replace damaged or bent parts.

Rear (3000GT AWD)

Check rear toe-in. See appropriate table under WHEEL ALIGNMENT SPECIFICATIONS. If rear toe-in is not within specification, loosen both trailing arm eccentric cam nuts. Turn trailing arm eccentric cam bolts equal amount to obtain correct rear toe-in. See Fig. 8.

Rear (Except Montero, Montero Sport & 3000GT AWD)

Check rear toe-in. See appropriate table under WHEEL ALIGNMENT SPECIFICATIONS. If rear toe-in is not within specification, loosen both assist link eccentric cam nuts. Turn assist link eccentric cam bolts equal amount to obtain correct rear toe-in. See Fig. 9.

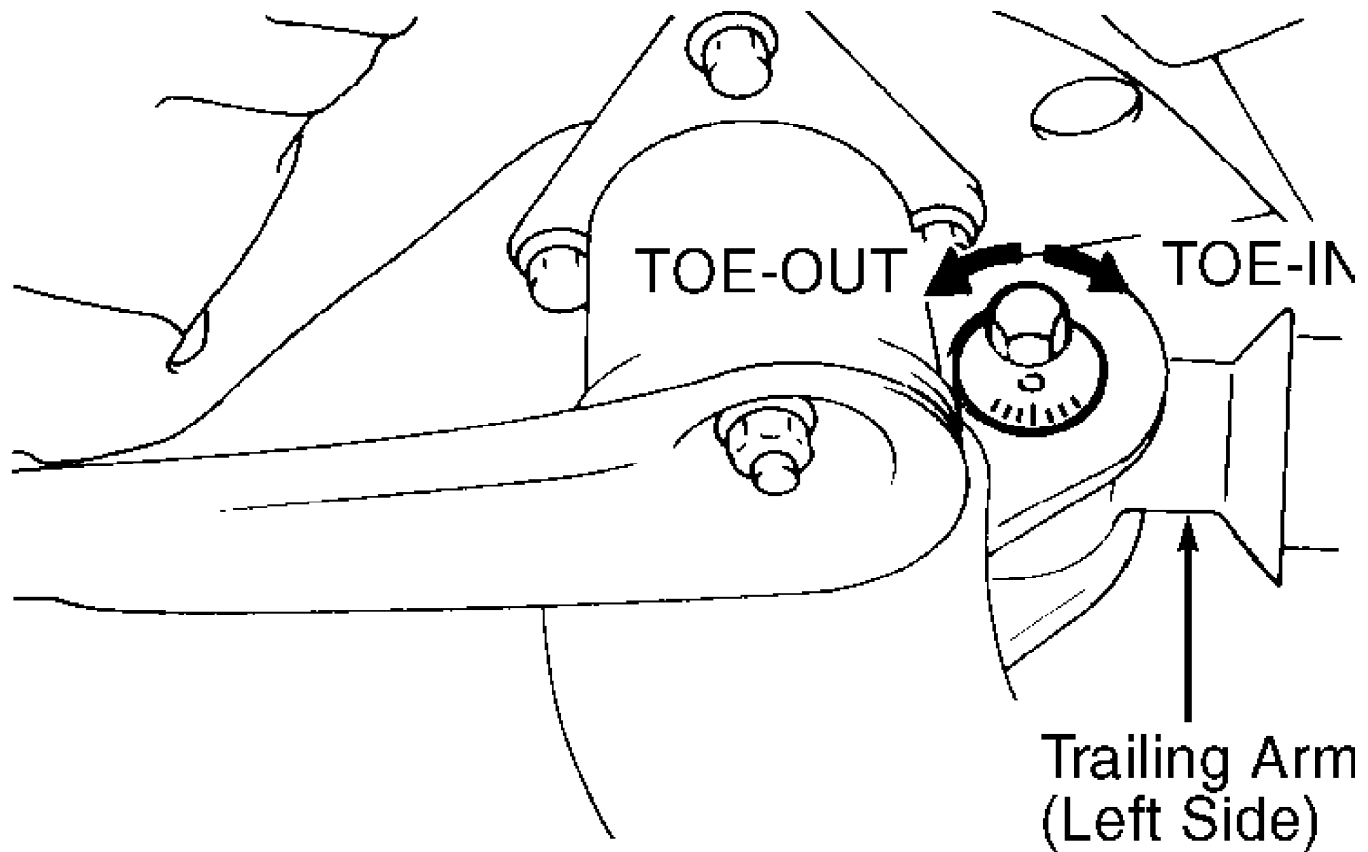

**93B00324**

Fig. 8: Adjusting Rear Toe-In (3000GT AWD)  
Courtesy of Mitsubishi Motor Sales of America.

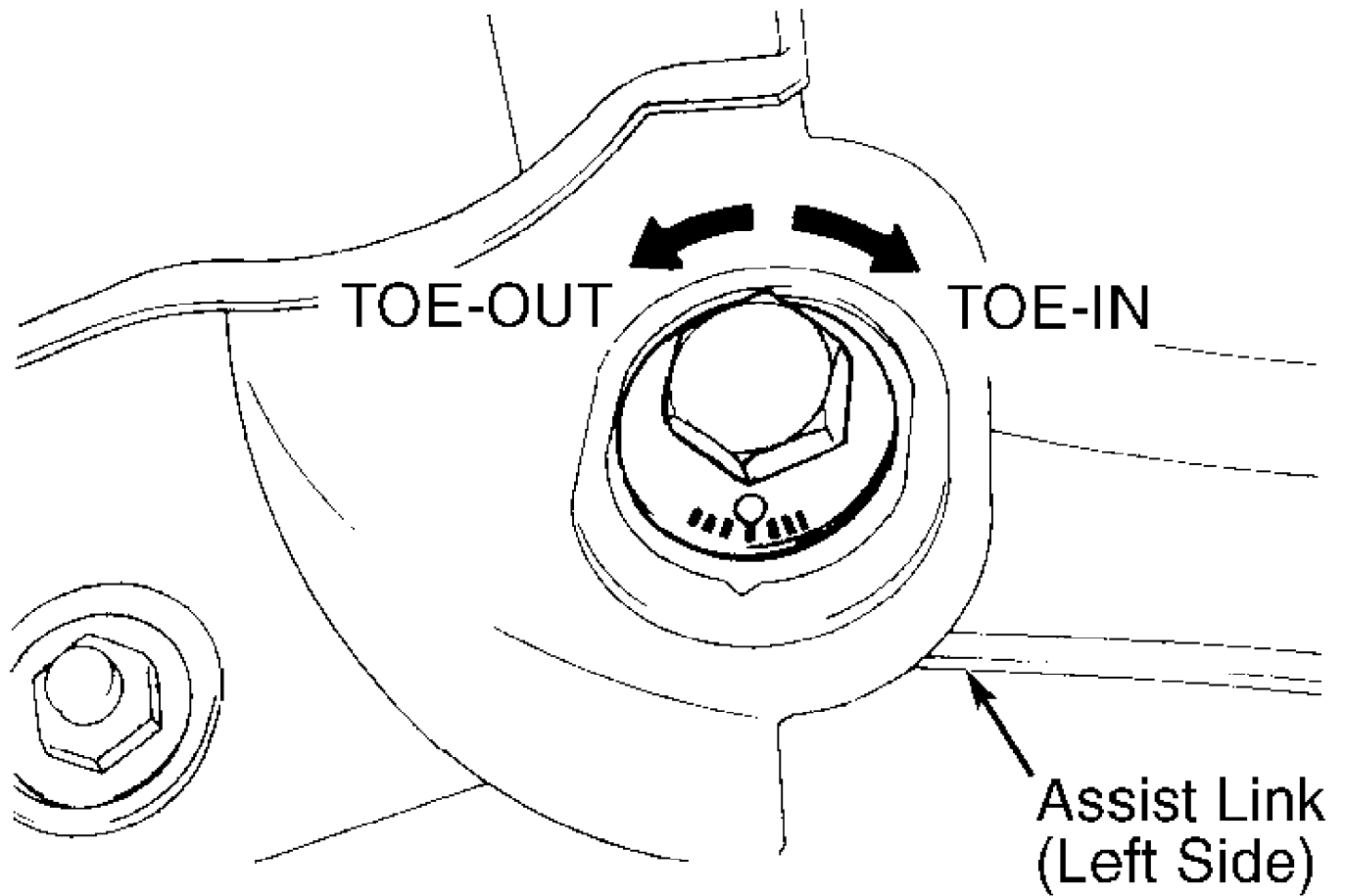

**93A00323**

Fig. 9: Adjusting Rear Toe-In (Typical)  
 Courtesy of Mitsubishi Motor Sales of America.

**TORQUE SPECIFICATIONS**

TORQUE SPECIFICATIONS

Application	Ft. Lbs. (N.m)
Shock Absorber-To-Lower Control Arm Bolt	
Montero .....	65-76 (88-103)
Montero Sport .....	(1)
Upper Arm Shaft To Crossmember Nut	
Montero .....	80 (108)
Montero Sport .....	72-87 (98-118)
Wheel Lug Nut	
Diamante, Galant & Mirage .....	65-80 (88-108)
Eclipse & 3000GT .....	87-101 (118-137)
Montero .....	72-87 (98-118)
Montero Sport	
With 6" Wide Wheel (6JJ) .....	87-101 (118-137)
With 7" Wide Wheel (7JJ) .....	73-86 (99-117)
	INCH Lbs. (N.m)
Shock Absorber-To-Crossmember Nut	
Montero .....	133 (15)



Montero Sport ..... 106-159 (12-18)

(1) - 80-124 INCH Lbs. (9-14 N.m).

### WHEEL ALIGNMENT SPECIFICATIONS

#### WHEEL ALIGNMENT SPECIFICATIONS (DIAMANTE)

Application	Preferred	Range
Camber (1)		
Front .....	0 .....	-0.5 To 0.5
Rear		
15" Wheel .....	-.67 .....	-1.17 To -.17
16" Wheel .....	-.83 .....	-1.33 To -.33
Caster (Front) (1) .....	3 .....	2.5 To 3.5
Toe-In (1)		
Front .....	0 .....	-0.24 To 0.24
Rear .....	0 .....	-0.24 To 0.24
Toe-In (2)		
Front .....	0 (0) .....	-0.12 To 0.12 (-3 To 3)
Rear .....	0 (0) .....	-0.12 To 0.12 (-3 To 3)

(1) - Measurement in degrees.  
(2) - Measurement in inches (mm).

#### WHEEL ALIGNMENT SPECIFICATIONS (ECLIPSE)

Application	Preferred	Range
2WD		
14" & 17" Wheels		
Camber (1)		
Front .....	-0.33 .....	-0.83 To 0.17
Rear .....	-1.33 .....	-1.83 To -0.83
Caster (1) .....	4.67 .....	3.67 To 5.67
Toe-In (1)		
Front .....	0 .....	-0.24 To 0.24
Rear .....	0.24 .....	0 To 0.48
Toe-In (2)		
Front .....	0 (0) .....	-0.12 To 0.12 (-3 To 3)
Rear .....	0.12 (3) .....	0 To 0.24 (0 To 6)
Toe-Out On Turns (1)		
Inner .....	32.5 .....	N/A
Outer .....	27 .....	N/A
16" Wheel		
Camber (1)		
Front .....	-0.33 .....	-0.83 To 0.17
Rear .....	-1.67 .....	-2.17 To -1.17
Caster (1) .....	4.67 .....	3.67 To 5.67
Toe-In (1)		
Front .....	0 .....	-0.24 To 0.24
Rear .....	0.24 .....	0 To 0.48
Toe-In (2)		
Front .....	0 (0) .....	-0.12 To 0.12 (-3 To 3)
Rear .....	0.12 (3) .....	0 To 0.24 (0 To 6)
Toe-Out On Turns (1)		
Inner .....	32.5 .....	N/A
Outer .....	27 .....	N/A

AWD

Camber (1)			
Front	.....	-0.33	..... -0.83 To 0.17
Rear	.....	-1.33	..... -1.83 To -0.83
Caster (1)			
	.....	4.67	..... 3.67 To 5.67
Toe-In (1)			
Front	.....	0 (0)	..... -0.12 To 0.12 (-3 To 3)
Rear	.....	0.12 (3)	..... 0 To 0.24 (0 To 6)
Toe-In (2)			
Front	.....	0	..... -0.24 To 0.24
Rear	.....	0.24	..... 0 To 0.48
Toe-Out On Turns (1)			
Inner	.....	32.5	..... N/A
Outer	.....	27	..... N/A

(1) - Measurement in degrees.  
(2) - Measurement in inches (mm).

WHEEL ALIGNMENT SPECIFICATIONS (GALANT)

Application	Preferred	Range
Camber (1)		
Front	..... 0	..... -0.50 To 0.50
Rear	..... -1.33	..... -1.83 To -0.83
Caster (1)		
	..... 4.33	..... 3.83 To 4.83
Toe-In (1)		
Front	..... 0	..... -0.24 To 0.24
Rear	..... 0.24	..... 0 To 0.48
Toe-In (2)		
Front	..... 0 (0)	..... -0.12 To 0.12 (-3 To 3)
Rear	..... .12 (3)	..... 0 To .24 (0 To 6)
Toe-Out On Turns (1)		
Inner	..... 39	..... N/A
Outer	..... 30.5	..... N/A

(1) - Measurement in degrees.  
(2) - Measurement in inches (mm).

WHEEL ALIGNMENT SPECIFICATIONS (MIRAGE)

Application	Preferred	Range
Camber (1)		
Front	..... 0	..... -0.5 To 0.5
Rear	..... -0.67	..... -1.17 To -0.17
Caster (1)		
	..... 2.85	..... 2.35 To 3.35
Toe-In (1)		
Front	..... 0	..... -0.24 To 0.24
Rear	..... 0.24	..... 0.08 To 0.40
Toe-In (2)		
Front	..... 0 (0)	..... -0.12 To 0.12 (-3 To 3)
Rear	..... 0.12 (3)	..... 0.04 To 0.20 (1 To 5)
Toe-Out On Turns (1)		
Inner	..... 37.3	..... N/A
Outer	..... 31	..... N/A

(1) - Measurement in degrees.  
(2) - Measurement in inches (mm).

WHEEL ALIGNMENT SPECIFICATIONS (MONTERO)

---

Application	Preferred	Range
Camber (1)		
Front .....	0.67 .....	0.17 To 1.17
Caster (1) .....	3 .....	2 To 4
Toe-In (1)		
Front .....	0.28 .....	0 To 0.56
Toe-In (2)		
Front .....	0.14 (3.5) .....	0 To 0.28 (0 To 7)
Toe-Out On Turns (1)		
Inner .....	21.93 .....	N/A
Outer .....	20 .....	N/A

(1) - Measurement in degrees.  
(2) - Measurement in inches (mm).

---

WHEEL ALIGNMENT SPECIFICATIONS (MONTERO SPORT)

---

Application	Preferred	Range
Camber		
Front (1) .....	0.67 .....	0.17 To 1.17
Caster (1) .....	2.67 .....	1.67 To 3.67
Toe-In (1)		
Front .....	0.28 .....	0 To 0.56
Toe-In (2)		
Front .....	0.14 (3.5) .....	0 To 0.28 (0 To 7)

(1) - Measurement in degrees.  
(2) - Measurement in inches (mm).

---

WHEEL ALIGNMENT SPECIFICATIONS (3000GT)

---

Application	Preferred	Range
Camber (1)		
Front .....	0 .....	-0.5 To 0.5
Rear		
FWD .....	0 .....	-0.5 To 0.5
AWD .....	-0.17 .....	-0.67 To 0.33
Caster (1) .....	3.92 .....	3.42 To 4.42
Toe-In (1)		
Front .....	0 .....	-0.24 To 0.24
Rear .....	-0.02 .....	-0.16 To 0.20
Toe-In (2)		
Front .....	0 (0) .....	-0.12 To 0.12 (-3 To 3)
Rear .....	0.01 (0.5) .....	-0.08 To 0.10 (-2 To 3)
Toe-Out On Turns (1)		
Inner .....	33.75 .....	N/A
Outer .....	28.35 .....	N/A

(1) - Measurement in degrees.  
(2) - Measurement in inches (mm).

---