GROUP 11**ENGINE****CONTENTS**

ENGINE MECHANICAL <2.4L>	11A
ENGINE OVERHAUL <2.4L>	11B
ENGINE MECHANICAL <3.0L>	11C
ENGINE OVERHAUL <3.0L>	11D

GROUP 11A

ENGINE MECHANICAL

<2.4L>

CONTENTS

GENERAL DESCRIPTION	11A-3	OIL PAN	11A-20
ENGINE DIAGNOSIS	11A-3	REMOVAL AND INSTALLATION	11A-20
SPECIAL TOOLS	11A-4	INSPECTION.....	11A-22
ON VEHICLE SERVICE	11A-6	CRANKSHAFT FRONT OIL SEAL	11A-22
DRIVE BELT TENSION CHECK AND ADJUSTMENT	11A-6	REMOVAL AND INSTALLATION	11A-22
IGNITION TIMING CHECK.....	11A-6	CRANKSHAFT REAR OIL SEAL	11A-24
IDLE MIXTURE CHECK.....	11A-7	REMOVAL AND INSTALLATION	11A-24
CURB IDLE SPEED CHECK	11A-8	CYLINDER HEAD GASKET	11A-25
COMPRESSION PRESSURE CHECK....	11A-8	REMOVAL AND INSTALLATION	11A-25
MANIFOLD VACUUM CHECK.....	11A-9	TIMING BELT	11A-30
LASH ADJUSTER CHECK.....	11A-10	REMOVAL AND INSTALLATION	11A-30
ENGINE ASSEMBLY	11A-13	TIMING BELT B	11A-34
REMOVAL AND INSTALLATION	11A-13	REMOVAL AND INSTALLATION	11A-34
CAMSHAFT AND CAMSHAFT OIL SEAL	11A-17	SPECIFICATIONS	11A-36
REMOVAL AND INSTALLATION	11A-17	FASTENER TIGHTENING SPECIFICATIONS	11A-36
		SERVICE SPECIFICATIONS	11A-37
		SEALANTS AND ADHESIVES	11A-38

GENERAL DESCRIPTION

M1111000100152

The 4G64 (2.4L) engine is an in-line four cylinder engine. The cylinder numbers are assigned as 1-2-3-4 from the front of the engine (timing belt side). This engine is fired in the order of the 1, 3, 4 and 2 cylinders.

ITEMS		SPECIFICATIONS	
Type		In-line SOHC	
Number of cylinders		4	
Bore mm (in)		86.5 (3.41)	
Stroke mm (in)		100.0 (3.94)	
Piston displacement cm ³ (cu in)		2,351 (143.4)	
Compression ratio		9.0	
Firing order		1-3-4-2	
Counterbalance shaft		Equipped	
Valve timing	Intake valve	Opens (BTDC)	16°
		Closes (ABDC)	53°
	Exhaust valve	Opens (BBDC)	50°
		Closes (ATDC)	16°
Lubrication		Pressure feed-full flow filtration	
Oil pump type		Involute gear type	

ENGINE DIAGNOSIS

M1111000700110



SYMPTOMS	PROBABLE CAUSE	REMEDY
Compression is too low	Blown cylinder head gasket	Replace the gasket
	Worn or damaged piston rings	Replace the rings
	Worn piston or cylinder	Repair or replace the piston and/or the cylinder block
	Worn or damaged valve seat	Repair or replace the valve and/or the seat ring
Drop in oil pressure	Engine oil level is too low	Check the engine oil level
	Malfunction of oil pressure switch	Replace the oil pressure switch
	Clogged oil filter	Install a new filter
	Worn oil pump gears or cover	Replace the gears and/or the cover
	Thin or diluted engine oil	Change the engine oil to correct viscosity
	Stuck (opened) oil relief valve	Repair the relief valve
	Excessive bearing clearance	Replace the bearings
Oil pressure too high	Stuck (closed) oil relief valve	Repair the relief valve

SYMPTOMS	PROBABLE CAUSE	REMEDY
Noisy valves	Malfunction of lash adjuster (including entry of air into high pressure chamber)	Check the lash adjuster
	Thin or diluted engine oil (low oil pressure)	Change the engine oil
	Worn or damaged valve stem or valve guide	Replace the valve and/or the guide
Connecting rod noise/ main bearing noise	Insufficient oil supply	Check the engine oil level
	Thin or diluted engine oil	Change the engine oil
	Excessive bearing clearance	Replace the bearings

SPECIAL TOOLS

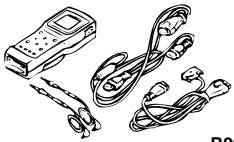
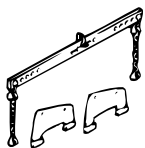
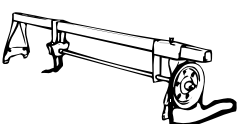
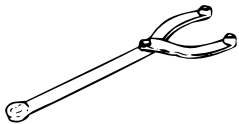
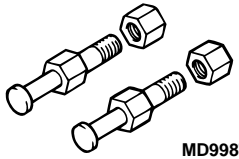
M1111000600113

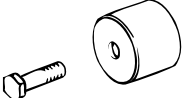
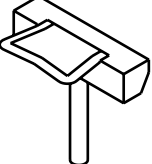
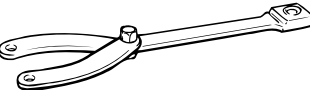
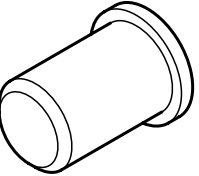
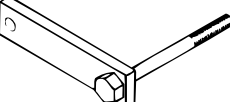
TOOL	TOOL NUMBER AND NAME	SUPERSESSION	APPLICATION
 <p>B991502</p>	MB991502 Scan tool (MUT-II)	MB991496-OD	<ul style="list-style-type: none"> Ignition timing check Idle speed check
 <p>MB991453</p>	MB991453 Engine hanger assembly	MZ203827-01	Supporting the engine assembly during remove and installation of the transaxle
 <p>MZ203827</p>	GENERAL SERVICE TOOL MZ203827 Engine lifter	MZ203827-01	
 <p>MB990767</p>	MB990767 End yoke holder	MB990767-01	
 <p>MD998719</p>	MD998719 Crankshaft pulley holder pin	MT308239	

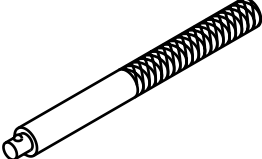
TOOL	TOOL NUMBER AND NAME	SUPERSESSION	APPLICATION
 <p align="right">D998443</p>	MD998443 Lash adjuster holder (8)	MD998443-01	Supporting of the auto-lash adjuster to prevent it from falling when rocker shaft assembly is removed or installed
 <p align="right">D998713</p>	MD998713 Camshaft oil seal installer	MD998713-01	Camshaft oil seal installation
	MD998727 Oil pan remover	MD998727-01	Oil pan removal
 <p align="right">B991367</p>	MB991367 Special spanner	MB991367-01	Holding the crankshaft sprocket
	MD998375 Crankshaft oil seal installer	MD998375-01	Crankshaft front oil seal installation
 <p align="right">D998781</p>	MD998781 Flywheel stopper	General service tool	Drive plate supporting
	MD998776 Crankshaft rear oil seal installer	MD998776-01	Crankshaft rear oil seal installation
	MB990938 Handle	MB990938-01	

TOOL	TOOL NUMBER AND NAME	SUPERSESSION	APPLICATION
	MB991654 Cylinder head bolt wrench (12)	General service tool	Removal and installation of cylinder head bolt
	MD998738 Adjusting screw	General service tool	<ul style="list-style-type: none"> • Holding the auto-tensioner • Timing belt tension adjustment
	MD998767 Tensioner pulley socket wrench	MD998752-01	Timing belt tension adjustment

ON VEHICLE SERVICE

DRIVE BELT TENSION CHECK AND ADJUSTMENT

M1111003100117

Refer to GROUP 00, Maintenance Service – Drive Belts (Check Condition) [P.00-39](#).

IGNITION TIMING CHECK

M1111001700094

Required Special Tool:

MB991502: Scan Tool (MUT-II)

1. Before inspection, set vehicles in the following condition:
 - Engine coolant temperature: 80 – 95°C (176 - 203° F)
 - Lights and all accessories: OFF
 - Transaxle: "P" range

CAUTION

To prevent damage to scan tool MB991502, always turn the ignition switch to the "LOCK" (OFF) position before connecting or disconnecting scan tool MB991502.

2. Connect scan tool MB991502 to the data link connector.
3. Set up a timing light.
4. Start the engine and run it at idle.
5. Check that the idle speed is approximately 700 r/min.
6. Select scan tool MB991502 actuator test "item number 17."
7. Check that basic ignition timing is within the standard value.

Standard value: 5° BTDC ± 3°

8. If the basic ignition timing is not within the standard value, check the following items:

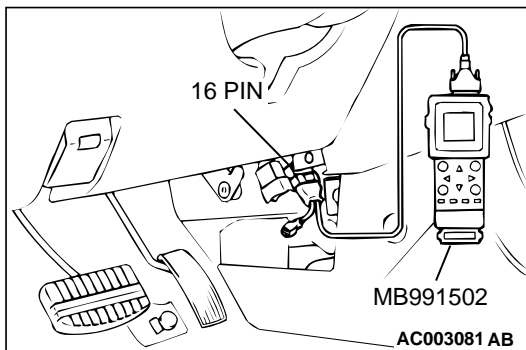

- Diagnosis output
- Timing belt cover and crankshaft position sensor installation conditions
- Crankshaft sensing blade condition

⚠ CAUTION

If the actuator test is not canceled, the forced drive will continue for 27 minutes. Driving in this state could lead to engine failure.

9. Press the clear key on scan tool MB991502 (select forced drive stop mode), and cancel the actuator test.
10. Check that the actual ignition timing is at the standard value.

Standard value: Approximately 10° BTDC

NOTE: Ignition timing fluctuates about ± 7° Before Top Dead Center, even under normal operating condition.

NOTE: It is automatically further advanced by about 5° to 10° Before Top Dead Center at higher altitudes.

IDLE MIXTURE CHECK

M1111002100095

Required Special Tool:

MB991502: Scan Tool (MUT-II)

1. Before inspection, set vehicles in the following condition:
 - Engine coolant temperature: 80 – 95°C (176 - 203°F)
 - Lights and all accessories: OFF
 - Transaxle: "P" range

⚠ CAUTION

To prevent damage to scan tool MB991502, always turn the ignition switch to the "LOCK" (OFF) position before connecting or disconnecting scan tool MB991502.

2. Connect scan tool MB991502 to the data link connector.
3. Check that the basic ignition timing is within the standard value.

Standard value: 5° BTDC ± 3°

4. Start the engine and increase the engine speed to 2,500 r/min for 2 minutes.
5. Set the CO, HC tester.
6. Check the CO contents and the HC contents at idle.

Standard value:

CO contents: 0.5% or less

HC contents: 100 ppm or less

7. If the CO and HC contents do not remain inside the standard value, check the following items:

NOTE: Replace the catalytic converter when the CO and HC contents do not remain inside the standard value, even though the result of the inspection is normal for all items.

- Diagnosis output
- Closed-loop control (When the closed-loop control is carried out normally, the output signal of the heated oxygen sensor changes between 0 – 400 mV and 600 – 1,000 mV at idle.)
- Fuel pressures

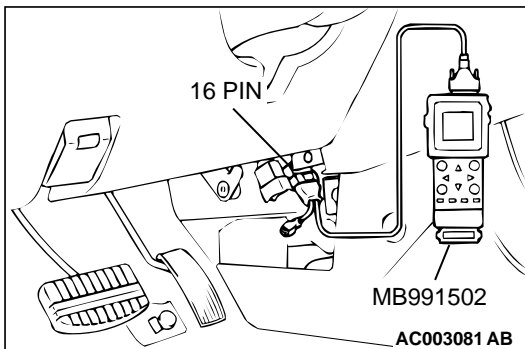

- Injector
- Ignition coil, spark plug cable, spark plug
- EGR system and EGR valve leak
- Evaporative emission control system
- Compression pressure

CURB IDLE SPEED CHECK

M1111003500104

Required Special Tool:

MB991502: Scan Tool (MUT-II)

1. Before inspection and adjustment set vehicles in the following condition.
 - Engine coolant temperature: 80 – 95°C (176 - 203°F)
 - Lights and all accessories: OFF
 - Transaxle: "P" range

⚠ CAUTION

To prevent damage to scan tool MB991502, always turn the ignition switch to the "LOCK" (OFF) position before connecting or disconnecting scan tool MB991502.

2. Connect scan tool MB991502 to the data link connector.
3. Check the basic ignition timing.

Standard value: 5° BTDC ± 3°

4. Start the engine.
5. Run the engine at idle for 2 minutes.
6. Check the idle speed. Select item number 22 and take a reading of the idle speed.

Curb idle speed: 700 ± 100 r/min

NOTE: The idle speed is controlled automatically by the idle air control system.

7. If the idle speed is outside the standard value, refer to GROUP 13A, Diagnosis – Symptom Chart [P.13A-22](#).

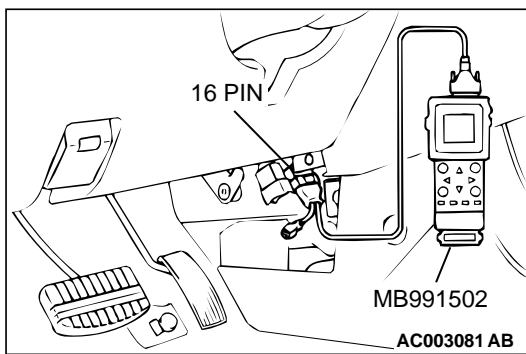

COMPRESSION PRESSURE CHECK

M1111002600089

1. Before inspection, check that the engine oil, starter and battery are normal. Also, set the vehicle in the following condition:
 - Engine coolant temperature: 80 – 95°C (176 - 203°F)
 - Lights, and all accessories: OFF
 - Transaxle: "P" range
2. Disconnect the spark plug cables.
3. Remove all of the spark plugs.
4. Disconnect the crankshaft position sensor connector.

NOTE: Doing this will prevent the engine control module from carrying out ignition and fuel injection.

⚠ WARNING

Keep your distance from the spark plug hole when cranking. Oil, fuel, etc., may spray out from the spark plug hole and may cause serious injury.

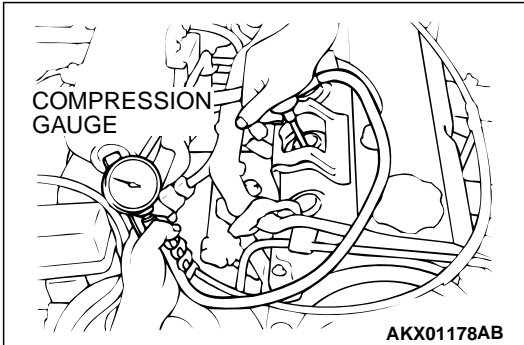

5. Cover the spark plug hole with a shop towel etc., during cranking. After the engine has been cranked, check for foreign material adhering to the shop towel.
6. Set compression gauge to one of the spark plug holes.
7. Crank the engine with the throttle valve fully open and measure the compression pressure.

**Standard value (at engine speed of 250 – 400 r/min):
1,275 kPa (185 psi)**

**Minimum limit (at engine speed of 250 – 400 r/min):
959 kPa (139 psi)**

8. Measure the compression pressure for all the cylinders, and check that the pressure differences of the cylinders are below the limit.

Limit: 98 kPa (14 psi)

9. If there is a cylinder with compression or a compression difference that is outside the limit, pour a small amount of engine oil through the spark plug hole, and repeat the operations in steps 6 to 8.
 - (1) If the compression increases after oil is added, the cause of the malfunction is a worn or damaged piston ring and/or cylinder inner surface.
 - (2) If the compression does not rise after oil is added, the cause is a burnt or defective valve seat, or pressure is leaking from the gasket.

10. Connect the crankshaft position sensor connector.

11. Install the spark plugs and spark plug cables.

12. Use the scan tool to erase the diagnostic trouble codes.

NOTE: This will erase the diagnostic trouble code resulting from the crankshaft position sensor connector being disconnected.

MANIFOLD VACUUM CHECK

M1111002700097

1. Before inspection, set vehicles in the following condition:
 - Engine coolant temperature: 80 – 95°C (176 - 203°F)
 - Lights and all accessories: OFF
 - Transmission: P range
2. Connect a tachometer.

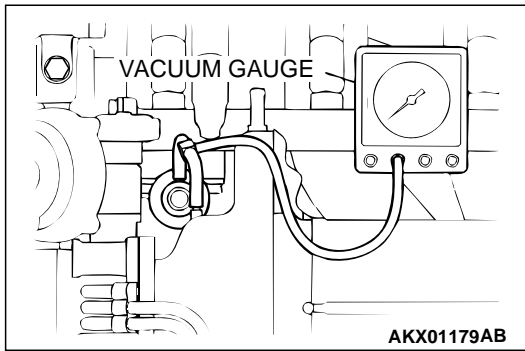

3. Attach a Tee-fitting union to the vacuum hose between the fuel pressure regulator and the intake manifold plenum, and connect a vacuum gauge.
4. Start the engine and check that idle speed is within specification. Then check the vacuum gauge reading.

Idle speed: 700 ± 100 r/min

Minimum limit: 60 kPa (18 in Hg)

LASH ADJUSTER CHECK

M1111002900109

If an abnormal noise (chattering noise) suspected to be caused by malfunction of the lash adjuster is produced immediately after starting the engine and does not disappear, perform the following check.

NOTE: An abnormal noise due to malfunction of the lash adjuster is produced immediately after starting the engine and changes with the engine speed, irrespective of the engine load. If, the abnormal noise is not produced immediately after starting the engine or does not change with the engine speed, or it changes with the engine load, the lash adjuster is not the cause for the abnormal noise.

NOTE: When the lash adjuster is malfunctioning, the abnormal noise is rarely eliminated by continuing the warming-up of the engine at idle speed.

However, the abnormal noise may disappear only when seizure is caused by oil sludge in the engine whose oil is not maintained properly.

1. Start the engine.
2. Check if the abnormal noise produced immediately after starting the engine, changes with the change in the engine speed.

If the abnormal noise is not produced immediately after starting the engine or it does not change with the engine speed, the lash adjuster is not the cause for the noise. Therefore, investigate other causes. The abnormal noise is probably caused by some other parts than the engine proper if it does not change with the engine speed. (In this case, the lash adjuster is in good condition.)
3. With the engine idling, change the engine load (shift from N to D range, for example) to make sure that there is no change in the level of abnormal noise.

If there is a change in the level of abnormal noise, suspect a tapping noise due to worn crankshaft bearing or connecting rod bearing. (In this case, the lash adjuster is in good condition.)
4. After completion of warm-up, run the engine at idle to check for abnormal noise.

If the noise is reduced or disappears, clean the lash adjuster (Refer to GROUP 11B-Engine overhaul – Rocker Arms and Camshaft – Inspection P.11B-28.) As it is suspected that the noise is due to seizure of the lash adjuster. If there is no change in the level of the abnormal noise, proceed to step 5.

5. Run the engine to bleed the lash adjuster system. (Refer to P.11A-11.)
6. If the abnormal noise does not disappear after air bleeding operation, clean the lash adjuster (Refer to GROUP 11B-Engine overhaul – Rocker Arms and Camshaft – Inspection P.11B-28.)

Bleeding lash adjuster system

NOTE: Parking the vehicle on a grade for a long time may decrease oil in the lash adjuster, causing air to enter the high pressure chamber when starting the engine.

NOTE: After parking for many hours, oil may run out from the oil passage and take time before oil is supplied to the lash adjuster, causing air to enter the high pressure chamber.

NOTE: In the above cases, abnormal noise can be eliminated by bleeding the lash adjuster system.

1. Check engine oil and add or change oil if required.

NOTE: If the engine oil level is low, air is sucked from the oil screen, causing air to enter the oil passage.

NOTE: If the engine oil level is higher than specification, oil may be stirred by the crankshaft, causing oil to be mixed with a large quantity of air.

NOTE: If oil is deteriorated, air is not easily separated from oil, increasing the quantity of air contained in oil.

NOTE: If air mixed with oil enters the high pressure chamber inside the lash adjuster from the above causes, air in the high pressure chamber is compressed excessively while the valve is opened, resulting in an abnormal noise when the valve closes.

This is the same phenomenon as that observed when the valve clearance has become excessive. The lash adjuster can resume normal function when air entered the lash adjuster is removed.

2. Idle the engine for one to three minutes to warm it up.

3. Repeat the operation pattern, shown in left figure, at no load to check for abnormal noise. (Usually the abnormal noise is eliminated after repetition of the operation 10 to 30 times. If, however, no change is observed in the level of abnormal noise after repeating the operation more than 30 times, suspect that the abnormal noise is due to some other factors.)

4. After elimination of abnormal noise, repeat the operation shown in left figure five more times.

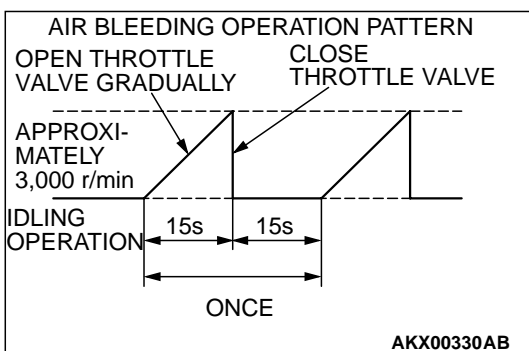
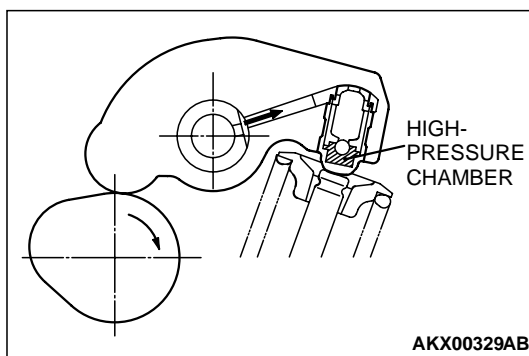
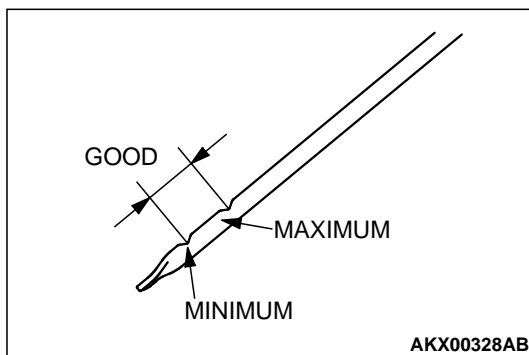

5. Run the engine at idle for one to three minutes to make sure that the abnormal noise has been eliminated.

ENGINE ASSEMBLY

REMOVAL AND INSTALLATION

M1112001000140

CAUTION

*: Indicates parts which should be temporarily tightened, and then fully tightened after placing the vehicle horizontally and loading the full weight of the engine on the vehicle body.

Pre-removal Operation

- Hood Removal (Refer to GROUP 42, Hood P.42-5.)
- Fuel Line Pressure Reduction [Refer to GROUP 13A, On-vehicle Service – Fuel Pump Relay Disconnection (How to Reduce Pressurized Fuel Lines)P.13A-442.]
- Engine Oil Draining (Refer to GROUP 12, On-vehicle Service – Engine Oil ReplacementP.12-3.)
- Engine Coolant Draining [Refer to GROUP 00, Maintenance Service – Engine Coolant (Change)P.00-50.]
- Air Cleaner Removal (Refer to GROUP 15, Air Cleaner P.15-4.)
- Thermostat Case Assembly Removal (Refer to GROUP 14, Water Hose and Water Pipe P.14-23.)
- Reserve Tank and Radiator Removal (Refer to GROUP 14, Radiator P.14-15.)
- Front Exhaust Pipe Removal (Refer to GROUP 15, Exhaust Pipe and Main Muffler P.15-18.)

Post-installation Operation

- Front Exhaust Pipe Installation (Refer to GROUP 15, Exhaust Pipe and Main Muffler P.15-18.)
- Reserve Tank and Radiator Installation (Refer to GROUP 14, Radiator P.14-15.)
- Thermostat Case Assembly Installation (Refer to GROUP 14, Water Hose and Water Pipe P.14-23.)
- Air Cleaner Installation (Refer to GROUP 15, Air Cleaner P.15-4.)
- Drive Belt Tension Adjustment [Refer to GROUP 00, Maintenance Service – Drive Belts (Check Condition)P.00-39.]
- Engine Oil Refilling (Refer to GROUP 12, On-vehicle Service – Engine Oil ReplacementP.12-3.)
- Engine Coolant Refilling [Refer to GROUP 00, Maintenance Service – Engine Coolant (Change)P.00-50.]
- Accelerator Cable Adjustment (Refer to GROUP 17, On-vehicle Service – Accelerator Cable Check and Adjustment P.17-4.)
- Hood Installation (Refer to GROUP 42, Hood P.42-5.)

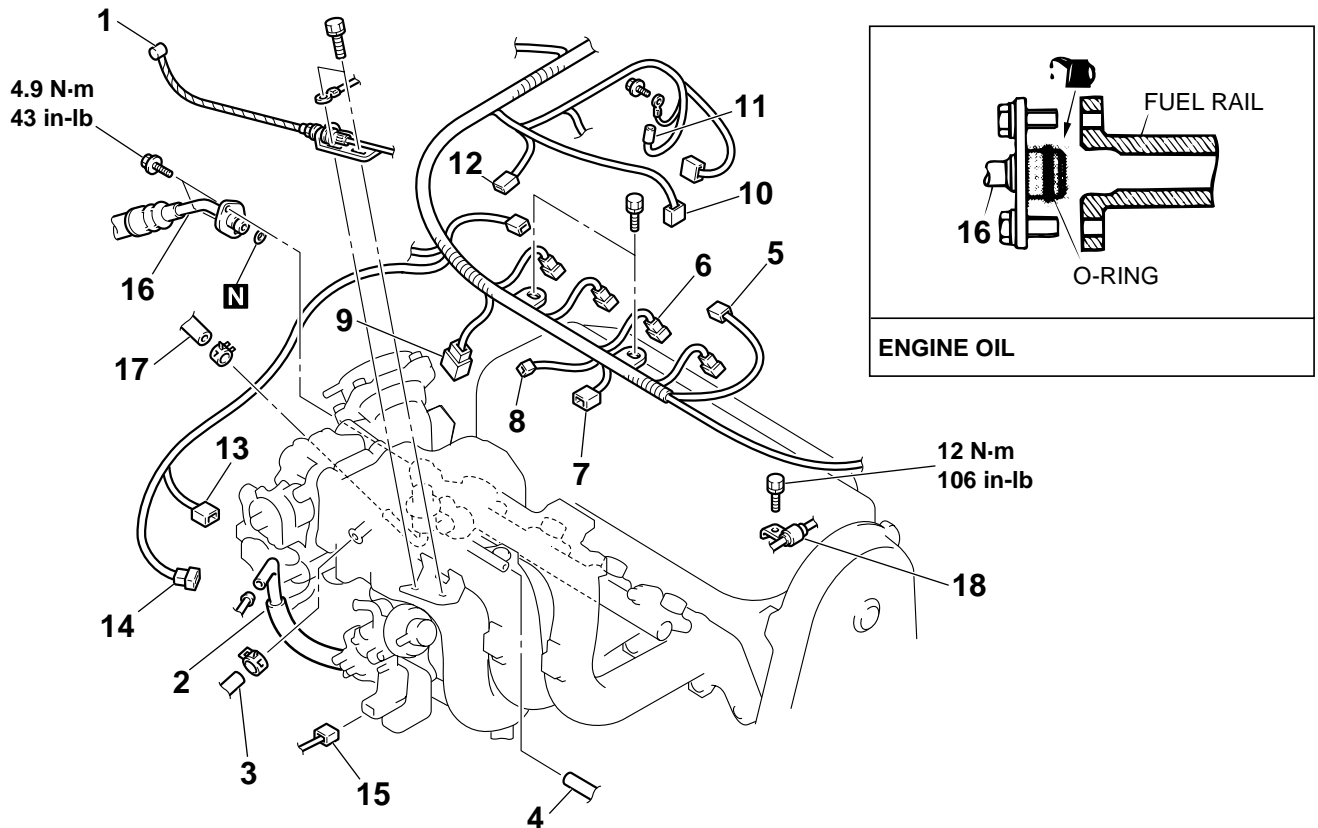

AC004548AB

TSB Revision

REMOVAL STEPS

1. ACCELERATOR CABLE CONNECTION
2. PURGE HOSE CONNECTION
3. BRAKE BOOSTER VACUUM HOSE CONNECTION
4. VACUUM HOSE CONNECTION <VEHICLES WITH AUTO-CRUISE CONTROL SYSTEM>
5. IGNITION COIL CONNECTOR
6. INJECTOR CONNECTOR
7. IGNITION FAILURE SENSOR CONNECTOR
8. MANIFOLD DIFFERENTIAL PRESSURE SENSOR CONNECTOR
9. THROTTLE POSITION SENSOR CONNECTOR

REMOVAL STEPS (Continued)

10. HEATED OXYGEN SENSOR (FRONT) CONNECTOR
11. CAPACITOR CONNECTOR
12. CAMSHAFT POSITION SENSOR CONNECTOR
13. IDLE AIR CONTROL MOTOR CONNECTOR
14. EVAPORATIVE EMISSION PURGE SOLENOID VALVE CONNECTOR
15. EGR SOLENOID VALVE CONNECTOR
16. HIGH-PRESSURE FUEL HOSE CONNECTION
17. FUEL RETURN HOSE CONNECTION
18. PRESSURE HOSE CONNECTION

>>D<<

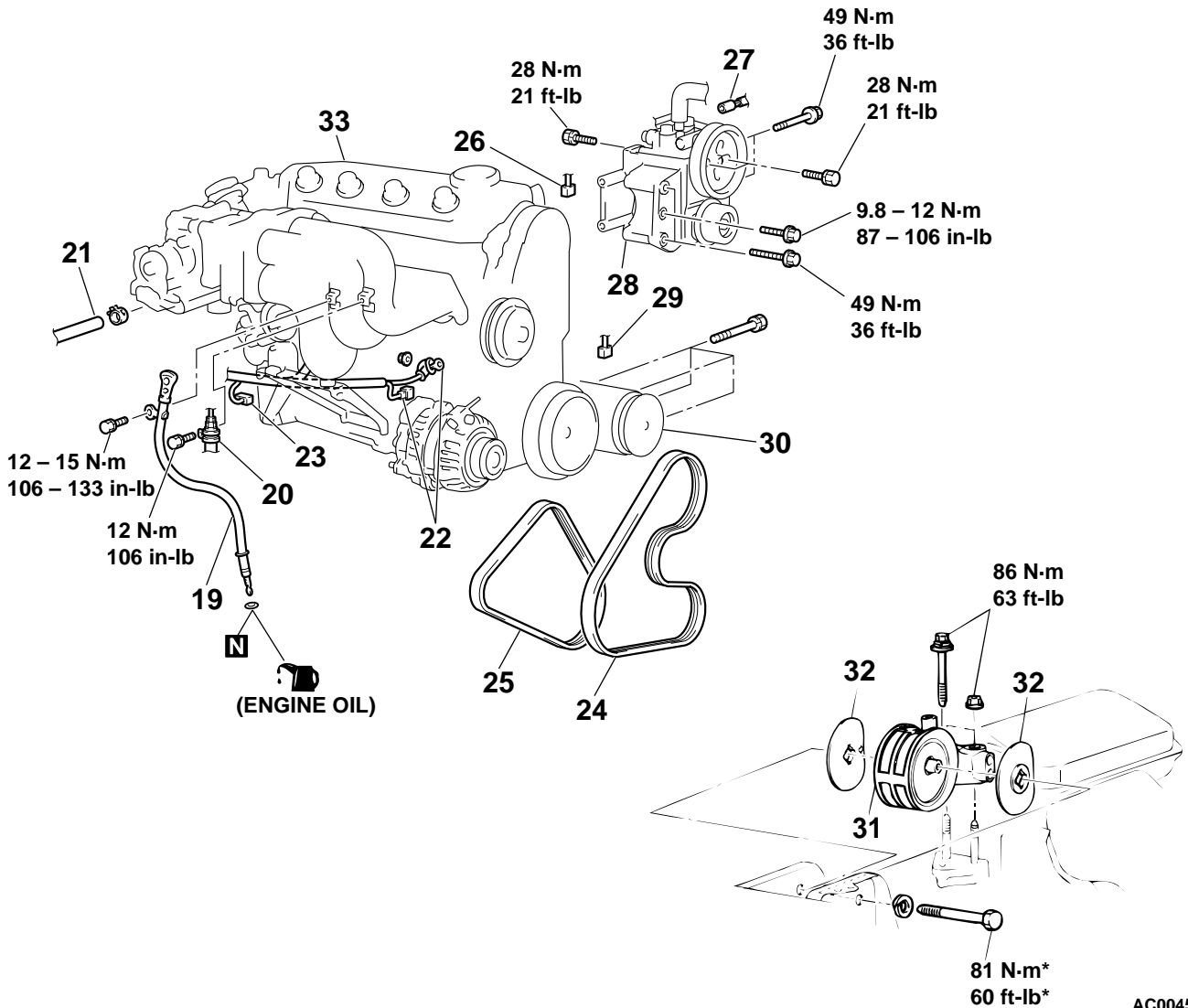

19. OIL DIPSTICK AND DIPSTICK GUIDE
20. PRESSURE HOSE CONNECTION

21. HEATER HOSE CONNECTION
22. GENERATOR CONNECTOR

AC004549AB

TSB Revision

- 23. OIL PRESSURE SWITCH CONNECTOR
- 24. DRIVE BELT (POWER STEERING OIL PUMP AND A/C COMPRESSOR)
- 25. DRIVE BELT (GENERATOR)
- 26. CRANKSHAFT POSITION SENSOR CONNECTOR
- 27. POWER STEERING PRESSURE SWITCH CONNECTOR
- <<A>> 28. POWER STEERING OIL PUMP AND BRACKET ASSEMBLY
- 29. A/C COMPRESSOR ASSEMBLY CONNECTOR
- <> 30. A/C COMPRESSOR
 - TRANSAXLE ASSEMBLY (REFER TO GROUP 23A, TRANSAXLE ASSEMBLY P.23A-290.)
- <<C>> >>C<<< 31. ENGINE MOUNT BRACKET
- >>B<<< 32. ENGINE MOUNT STOPPER
- <<D>> >>A<<< 33. ENGINE ASSEMBLY

Required Special Tools:

- MB991453: Engine Hanger Assembly
- MZ203827: Engine Lifter

REMOVAL SERVICE POINTS

<<A>> POWER STEERING OIL PUMP AND BRACKET ASSEMBLY REMOVAL

Remove the power steering oil pump and bracket assembly from the engine with the hose attached.

NOTE: Place the removed power steering oil pump in a place where it will not be a hindrance when removing and installing the engine assembly, and secure it with a cord or wire.

<> A/C COMPRESSOR REMOVAL

Remove the compressor from the compressor bracket with the hose still attached.

NOTE: Place the removed A/C compressor where it will not be a hindrance when removing and installing the engine assembly, and secure it with a cord or wire.

<<C>> ENGINE MOUNT BRACKET REMOVAL

1. Support the engine with a garage jack.
2. Remove special tools MB991453 and MZ203827 which was attached when the transaxle assembly was removed.
3. Hold the engine assembly with a chain block or similar tool.
4. Place a garage jack against the engine oil pan with a piece of wood in between, jack up the engine so that the weight of the engine is no longer being applied to the engine mount bracket, and then remove the engine mount bracket.

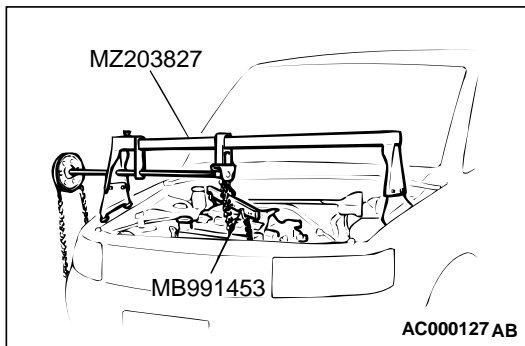

<<D>> ENGINE ASSEMBLY REMOVAL

After checking that all cables, hoses and harness connectors, etc., are disconnected from the engine, lift the chain block slowly to remove the engine assembly upward from the engine compartment.

INSTALLATION SERVICE POINTS

>>A<< ENGINE ASSEMBLY INSTALLATION

Install the engine assembly, checking that the cables, hoses, and harness connectors are not clamped.

>>B<< ENGINE MOUNT STOPPER INSTALLATION

Clamp the engine mount stopper so that the arrow points in the direction as shown in the diagram.

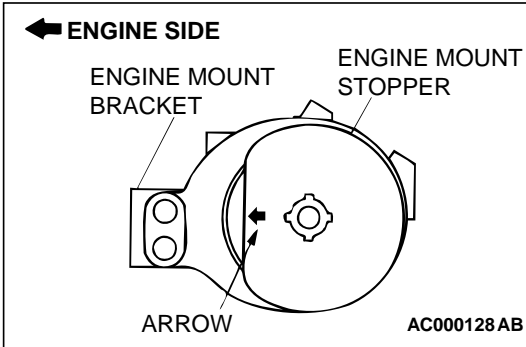

>>C<< ENGINE MOUNT BRACKET INSTALLATION

1. Place a garage jack against the engine oil pan with a piece of wood in between, and install the engine mount bracket while adjusting the position of the engine.
2. Support the engine with the garage jack.
3. Remove the chain block and support the engine assembly with special tools MB991453 and MZ203827.

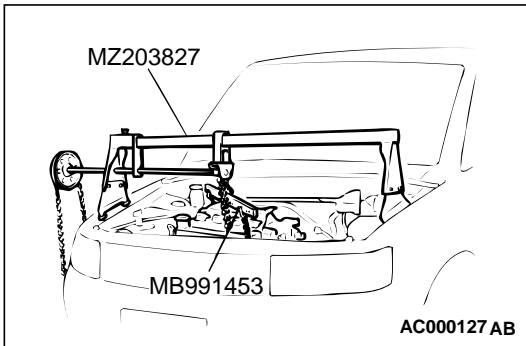

>>D<< HIGH-PRESSURE FUEL HOSE INSTALLATION

⚠ CAUTION

Do not allow any engine oil to enter the fuel rail.

1. Apply a small amount of new engine oil to the O-ring.
2. While turning the high-pressure fuel hose to the right and left, install it to the fuel rail, while being careful not to damage the O-ring. After installing, check that the hose turns smoothly.
3. If the hose does not turn smoothly, the O-ring is probably being clamped. Disconnect the high-pressure fuel hose and check the O-ring for damage. Replace if necessary.
4. Re-insert the fuel rail and confirm the hose turns smoothly.

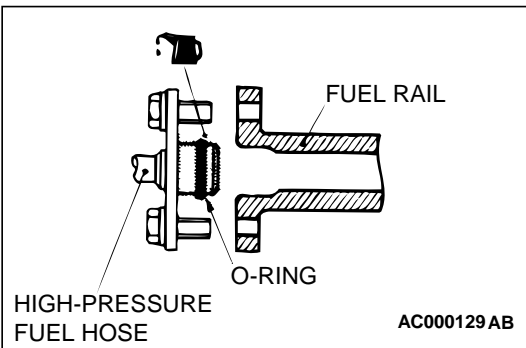

CAMSHAFT AND CAMSHAFT OIL SEAL

REMOVAL AND INSTALLATION

M1112001900110

Pre-removal and Post-installation Operation

- Air Cleaner Removal and Installation (Refer to GROUP 15, Air Cleaner P.15-4.)
- Timing Belt Removal and Installation (Refer to P.11A-30.)

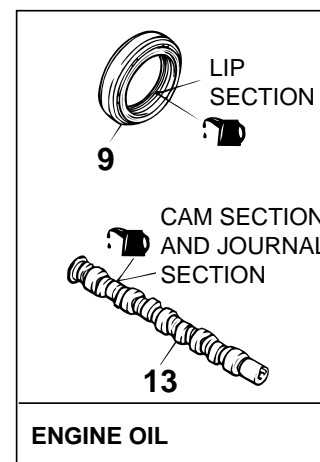
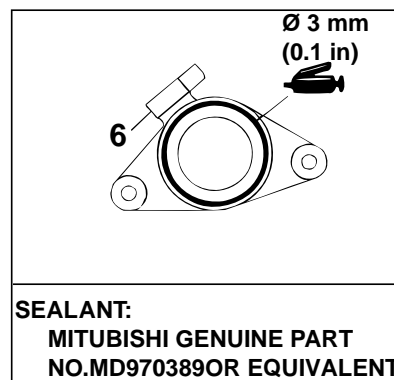
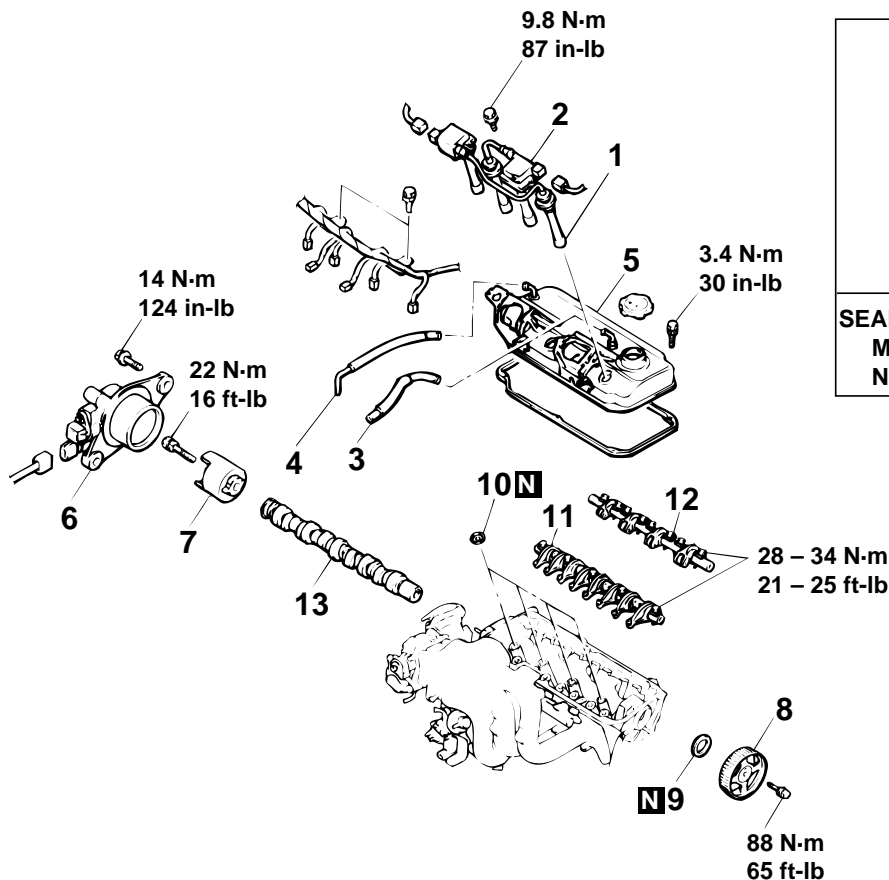

AC000130 AC

CAMSHAFT REMOVAL STEPS

1. SPARK PLUG CABLE
 2. IGNITION COIL
 3. PCV HOSE
 4. BREATHER HOSE
 5. ROCKER COVER
 6. CAMSHAFT POSITION SENSOR SUPPORT
 7. CAMSHAFT POSITION SENSING CYLINDER
 8. CAMSHAFT SPROCKET
- <<A>> >>C<<

<> >>A<<

<> >>A<<

<<A>> >>C<<

CAMSHAFT REMOVAL STEPS

10. SPARK PLUG GUIDE OIL SEAL
 11. ROCKER ARM AND SHAFT ASSEMBLY (INTAKE SIDE)
 12. ROCKER ARM AND SHAFT ASSEMBLY (EXHAUST SIDE)
 13. CAMSHAFT
- ### CAMSHAFT OIL SEAL REMOVAL STEPS
8. CAMSHAFT SPROCKET
 9. CAMSHAFT OIL SEAL

Required Special Tools:

- MB990767: End Yoke Holder
- MB998713: Crankshaft Oil Seal Installer

- MD998443: Auto-lash Adjuster Holder
- MD998719: Crankshaft Pulley Holder Pin

REMOVAL SERVICE POINTS

<<A>> CAMSHAFT SPROCKET REMOVAL

1. Use special tools MB990767 and MD998719 to loosen the camshaft sprocket securing bolt.
2. Remove the camshaft sprocket.

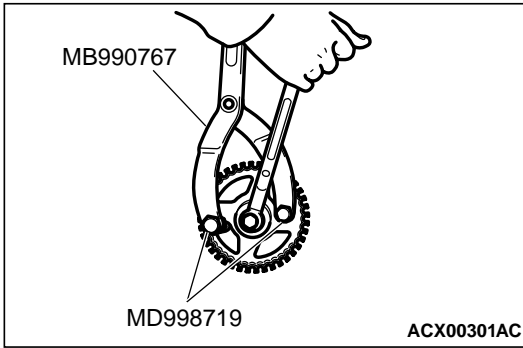

<> ROCKER ARM AND SHAFT ASSEMBLY REMOVA

1. Install special tool MD998443 as shown in the illustration so that the lash adjusters will not fall out.

⚠ CAUTION

Never disassemble the rocker arm and shaft assembly.

2. Loosen the rocker arm and shaft assembly mounting bolt, and then remove the rocker arm and shaft assembly with the bolt still attached.

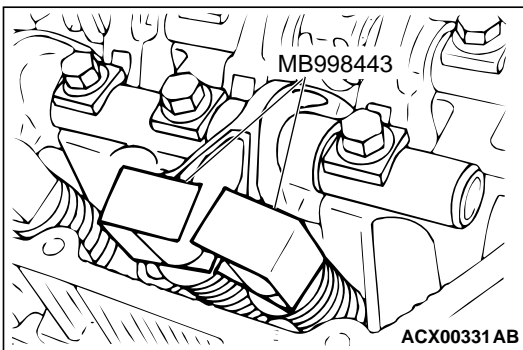

INSTALLATION SERVICE POINTS

>>A<< ROCKER ARM AND SHAFT ASSEMBLY INSTALLATION

1. Temporarily tighten the rocker shaft with the bolt so that all rocker arms do not push the valves.
2. Fit the rocker shaft spring from the above and position it so that it is right angles to the plug guide.

NOTE: Install the rocker shaft spring before installing the rocker arm and rocker arm shaft on the exhaust side.

3. Tighten the rocker arm and shaft assembly mounting bolt to the specified torque.

Tightening torque: 28 – 34 N·m (21 – 25 ft·lb)

4. Remove special tool MD998443.

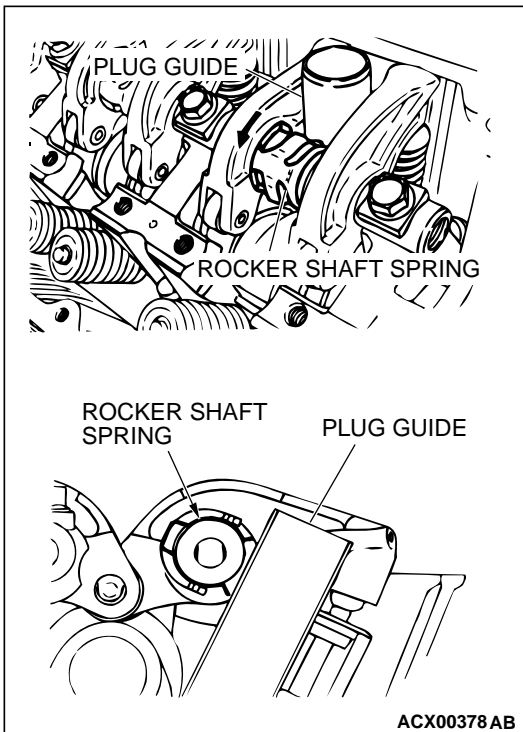

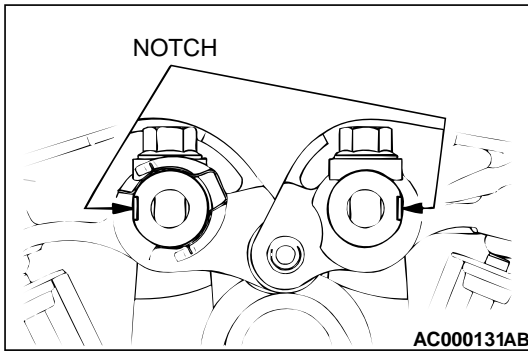

5. Make sure that the notch in the end of the rocker arm shaft is facing the direction shown.

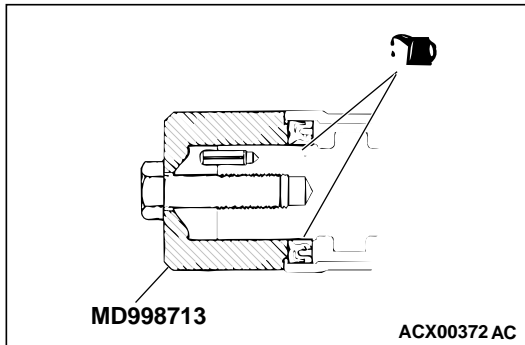

>>B<< CAMSHAFT OIL SEAL INSTALLATION

1. Apply engine oil to the camshaft oil seal lip.
2. Use special tool MD998713 to press-fit the camshaft oil seal.

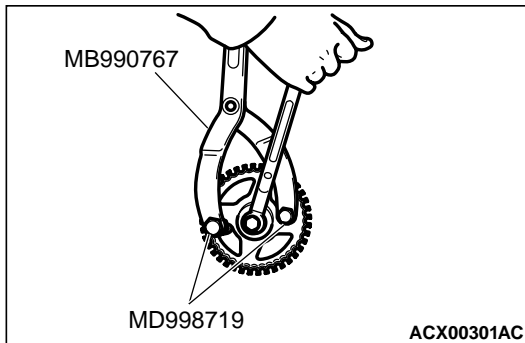

>>C<< CAMSHAFT SPROCKET INSTALLATION

1. Install the camshaft sprocket.
2. Use special tools MB990767 and MD998719 to tighten the camshaft sprocket securing bolt to the specified torque.

Tightening torque: 88 N·m (65 ft·lb)

OIL PAN

REMOVAL AND INSTALLATION

M1112002800127

- Pre-removal and Post-installation Operation**
- Engine Oil Draining and Refilling (Refer to GROUP 12, On-vehicle Service – Engine Oil Replacement P.12-3.)
 - Oil Dipstick Removal and Installation
 - Front Exhaust Pipe Removal and Installation (Refer to GROUP 15, Exhaust Pipe and Main Muffler P.15-18.)

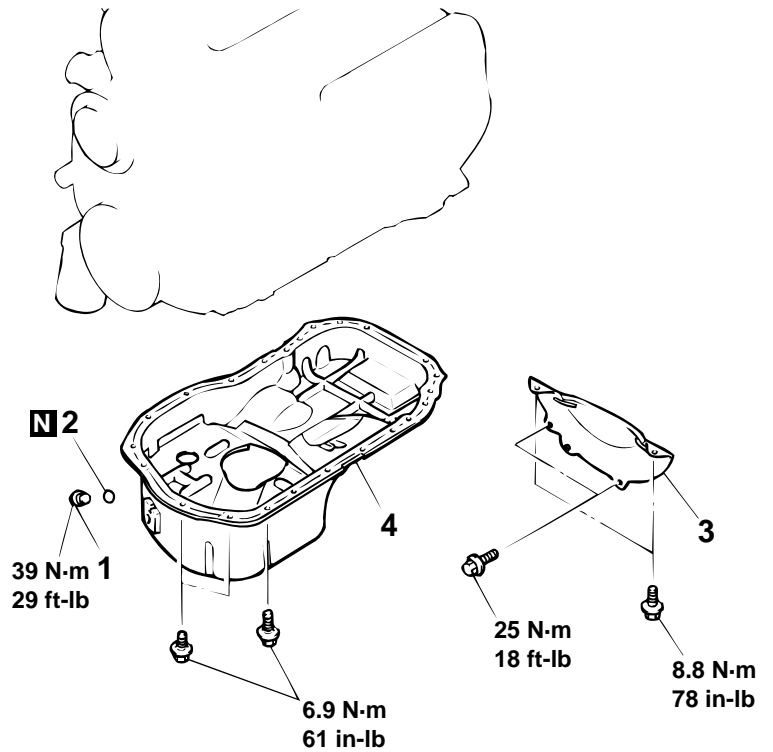
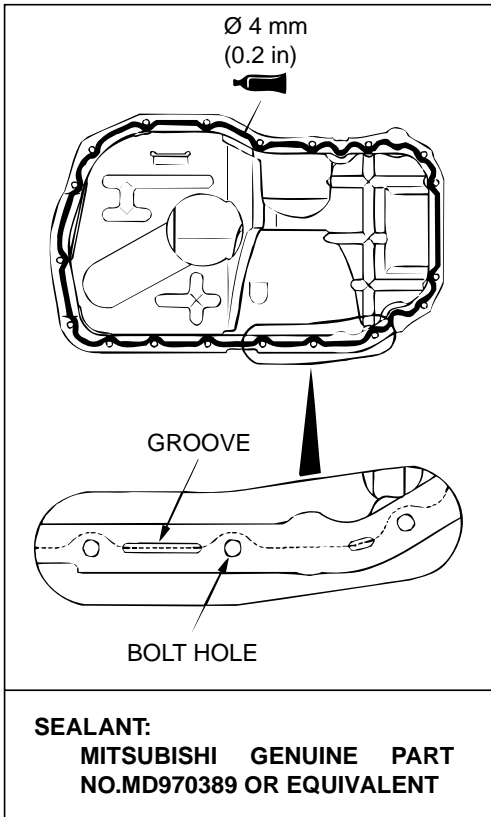

AC000132AC

REMOVAL STEPS

- >>B<< 1. DRAIN PLUG
2. DRAIN PLUG GASKET

REMOVAL STEPS (Continued)

- <<A>> >>A<< 3. BELL HOUSING COVER
4. OIL PAN

Required Special Tool:

- MD998727: Oil Pan Remover

REMOVAL SERVICE POINT

<<A>> OIL PAN REMOVAL

⚠ CAUTION

Perform this slowly to avoid deformation of the oil pan flange.

After removing the oil pan mounting bolts, remove the oil pan with special tool MD998727 and a brass bar.

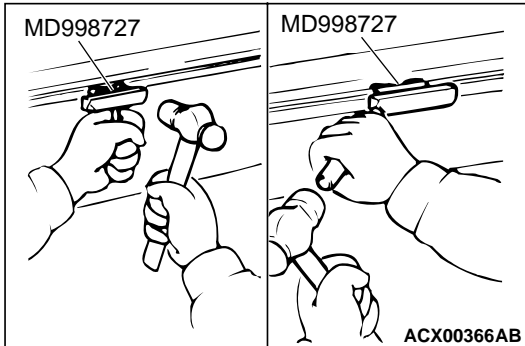

INSTALLATION SERVICE POINTS

>>A<< OIL PAN INSTALLATION

1. Remove sealant from the oil pan and cylinder block mating surfaces.
2. Degrease the sealant-coated surface and the engine mating surface.
3. Apply MITSUBISHI GENUINE PART number MD970389 or equivalent around the gasket surface of the oil pan.

NOTE: The sealant should be applied in a continuous bead approximately 4 mm (0.2 inch) in diameter.

⚠ CAUTION

After installing the oil pan, wait at least one hour before starting the engine.

4. Assemble the oil pan to the cylinder block within 15 minutes after applying the sealant.

Be careful when installing the oil pan. The bolts indicated in the illustration have different lengths from the other bolts.

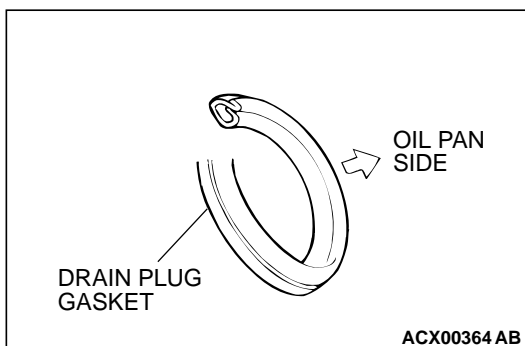
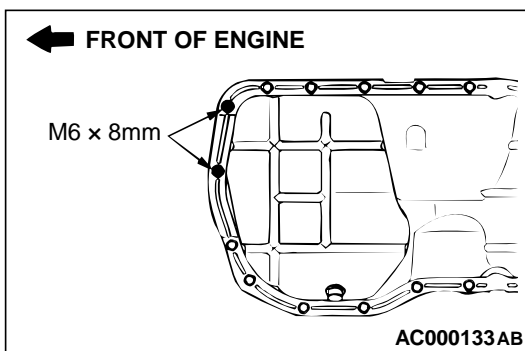

>>B<< DRAIN PLUG GASKET INSTALLATION

Install the drain plug gasket in the direction shown in the illustration.

INSPECTION

M1112002900072

- Check the oil pan for cracks.
- Check the oil pan sealant-coated surface for damage and deformation.

CRANKSHAFT FRONT OIL SEAL

REMOVAL AND INSTALLATION

M1112003400100

Pre-removal and Post-installation Operation

- Timing Belt Removal and Installation (Refer to [P.11A-30.](#))
- Crankshaft Position Sensor Removal and Installation (Refer to GROUP 16, Ignition System – Crankshaft Position Sensor <2.4L Engine> [P.16-49.](#))

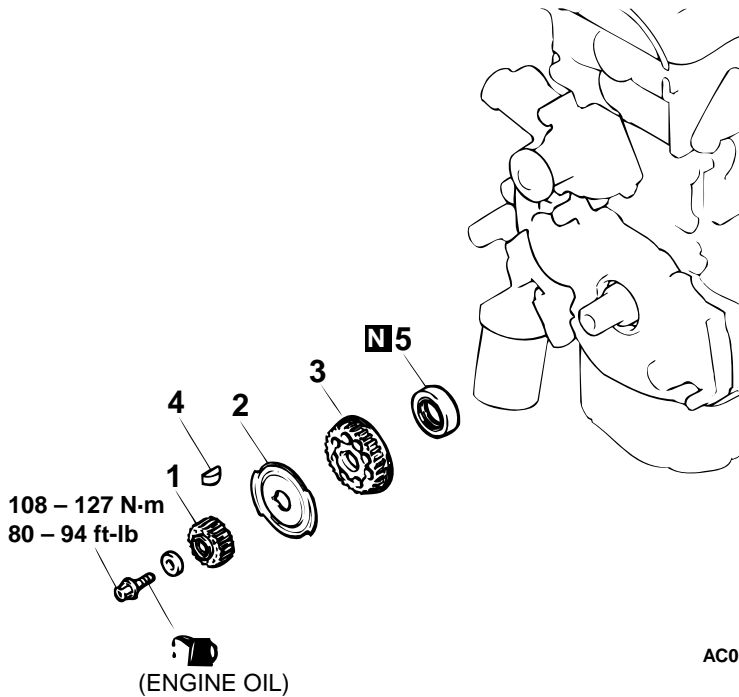
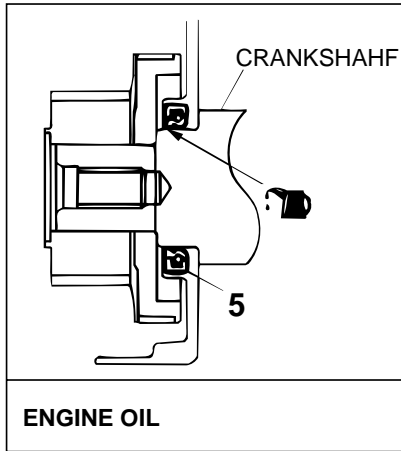

- REMOVAL STEPS**
- <<A>> >>B<< 1. CRANKSHAFT SPROCKET
- >>B<< 2. CRANKSHAFT SENSING BLADE
- TIMING BELT B (REFER TO [P.11A-34.](#))

- REMOVAL STEPS (Continued)**
- >>B<< 3. CRANKSHAFT SPROCKET B
4. KEY
- >>A<< 5. CRANKSHAFT FRONT OIL SEAL

Required Special Tools:

- MB991367: Special Spanner

- MB998375: Crankshaft Front Oil Seal Installation

TSB Revision

REMOVAL SERVICE POINT

<<A>> CRANKSHAFT SPROCKET REMOVAL

1. Use the crankshaft pulley mounting bolt to secure special tool MB991367.
2. Loosen the crankshaft sprocket mounting bolt, and remove the sprocket.

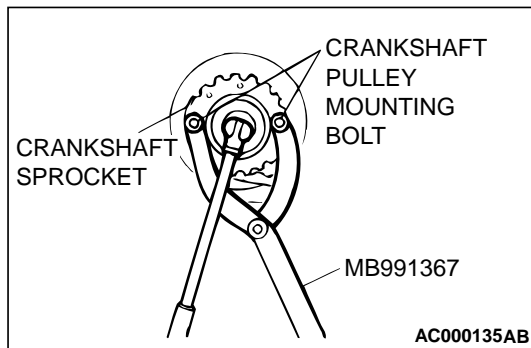

INSTALLATION SERVICE POINTS

>>A<< CRANKSHAFT FRONT OIL SEAL INSTALLATION

1. Apply engine oil to the entire inside diameter of the oil seal lip.
2. Use special tool MD998375 to press-fit the oil seal until it is flush with the front case.

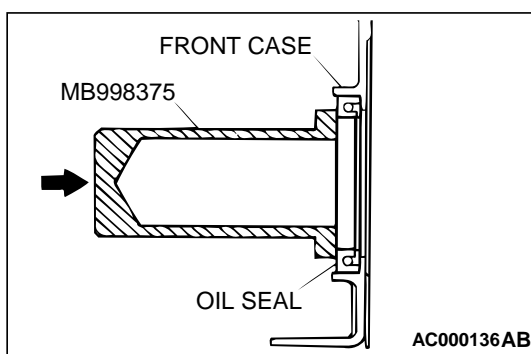

>>B<< CRANKSHAFT SPROCKET B/CRANKSHAFT SENSING BLADE/CRANKSHAFT SPROCKET INSTALLATION

1. To prevent the crankshaft bolt from loosening, degrease or clean the seating surfaces of the crankshaft, crankshaft sprocket B, crankshaft sensing blade and crankshaft at the shown positions.
2. Install the crankshaft sensing blade so that they face as shown in the illustration.
3. Apply the minimum amount of engine oil to the seat surface and thread of the crankshaft bolt.

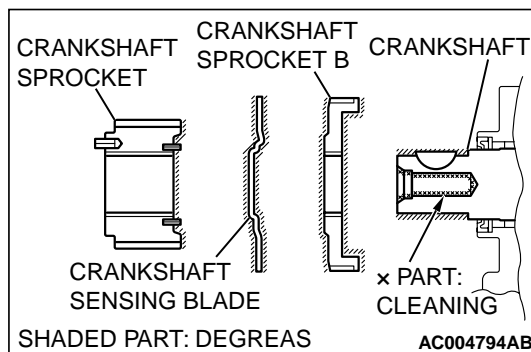

4. Use the crankshaft pulley mounting bolt to secure special tool MB991367.
5. Tighten the crankshaft sprocket bolt to the specified torque.

Tightening torque: 108 – 127 N·m (80 – 94 ft·lb)

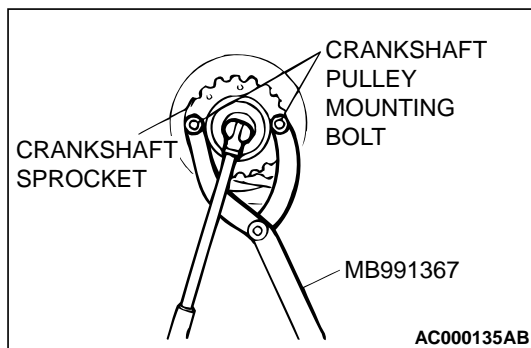

CRANKSHAFT REAR OIL SEAL

REMOVAL AND INSTALLATION

M1112003700101

- Pre-removal and Post-installation Operation**
- Oil Pan Removal and Installation (Refer to P.11A-20.)
 - Transaxle Assembly Removal and Installation (Refer to GROUP 23A, Transaxle Assembly P.23A-290.)

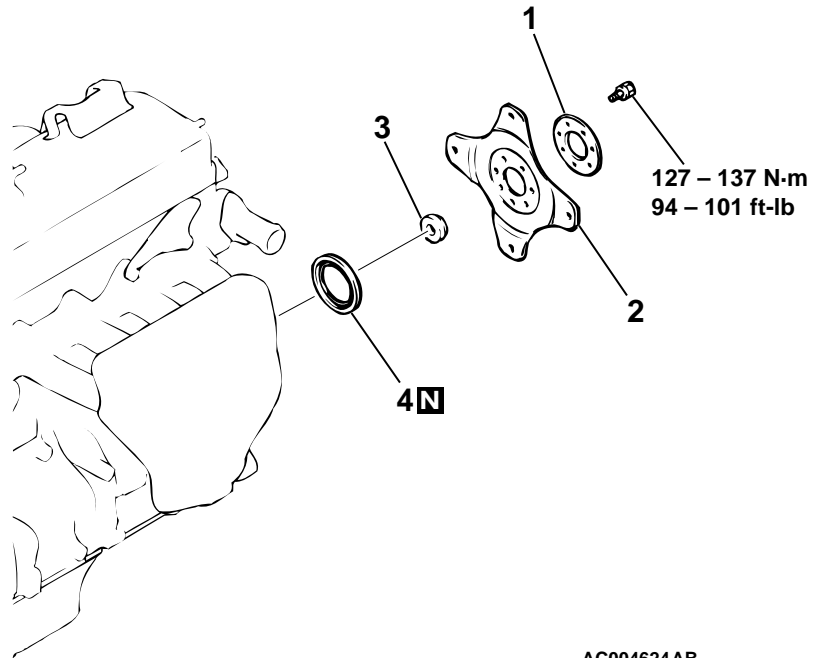
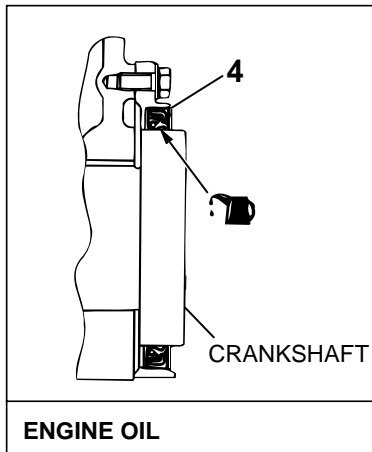

AC004624AB

- REMOVAL STEPS**
- <<A>> >>B<< 1. ADAPTER PLATE
<<A>> >>B<< 2. DRIVE PLATE

- REMOVAL STEPS (Continued)**
- >>A<< 3. CRANKSHAFT BUSHING
>>A<< 4. CRANKSHAFT REAR OIL SEAL

Required Special Tools:

- MB990938: Handle

- MD998776: Crankshaft Rear Oil Seal Installer
- MD998781: Flywheel Stopper

REMOVAL SERVICE POINT

<<A>> ADAPTER PLATE/DRIVE PLATE REMOVAL

Use special tool MD998781 to secure the drive plate, and remove the bolt.

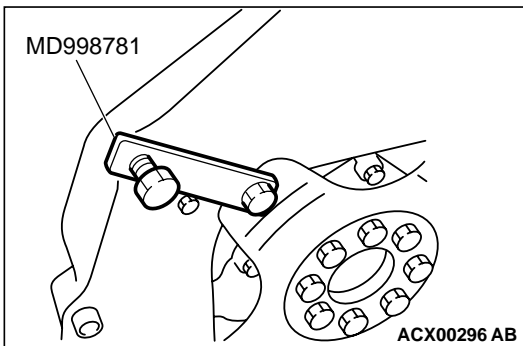

TSB Revision

INSTALLATION SERVICE POINTS

>>A<< CRANKSHAFT REAR OIL SEAL INSTALLATION

1. Apply a small amount of engine oil to the entire inside diameter of the oil seal lip.
2. Use special tools MB990938 and MD998776 to tap in the oil seal as shown in the illustration.

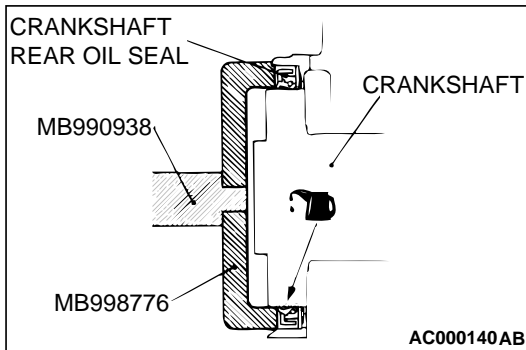

>>B<< DRIVE PLATE/ADAPTER PLATE INSTALLATION

Use special tool MD998781 to hold the drive plate in the same manner as removal, and install the bolt.

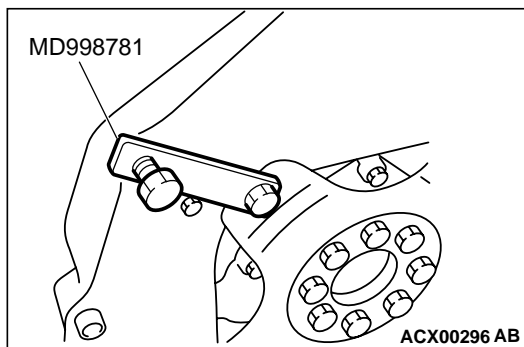

CYLINDER HEAD GASKET

REMOVAL AND INSTALLATION

M1112004000105

Pre-removal Operation

- Fuel Line Pressure Reduction [Refer to GROUP 13A, On-vehicle Service – Fuel Pump Relay Disconnection (How to Reduce Pressurized Fuel Lines)P.13A-442.]
- Engine Oil Draining (Refer to GROUP 12, On-vehicle Service – Engine Oil ReplacementP.12-3.)
- Engine Coolant Draining [Refer to GROUP 00, Maintenance Service – Engine Coolant (Change)P.00-50.]
- Air Cleaner Removal (Refer to GROUP 15, Air CleanerP.15-4.)
- Thermostat Case Assembly Removal (Refer to GROUP 14, Water Hose and Water PipeP.14-23.)
- Front Exhaust Pipe Removal (Refer to GROUP 15, Exhaust Pipe and Main MufflerP.15-18.)

Post-installation Operation

- Front Exhaust Pipe Installation (Refer to GROUP 15, Exhaust Pipe and Main MufflerP.15-18.)
- Thermostat Case Assembly Installation (Refer to GROUP 14, Water Hose and Water PipeP.14-23.)
- Air Cleaner Installation (Refer to GROUP 15, Air CleanerP.15-4.)
- Engine Oil Refilling (Refer to GROUP 12, On-vehicle Service – Engine Oil ReplacementP.12-3.)
- Engine Coolant Refilling [Refer to GROUP 00, Maintenance Service – Engine Coolant (Change)P.00-50.]
- Accelerator Cable Adjustment (Refer to GROUP 17, On-vehicle Service – Accelerator Cable Check and AdjustmentP.17-4.)

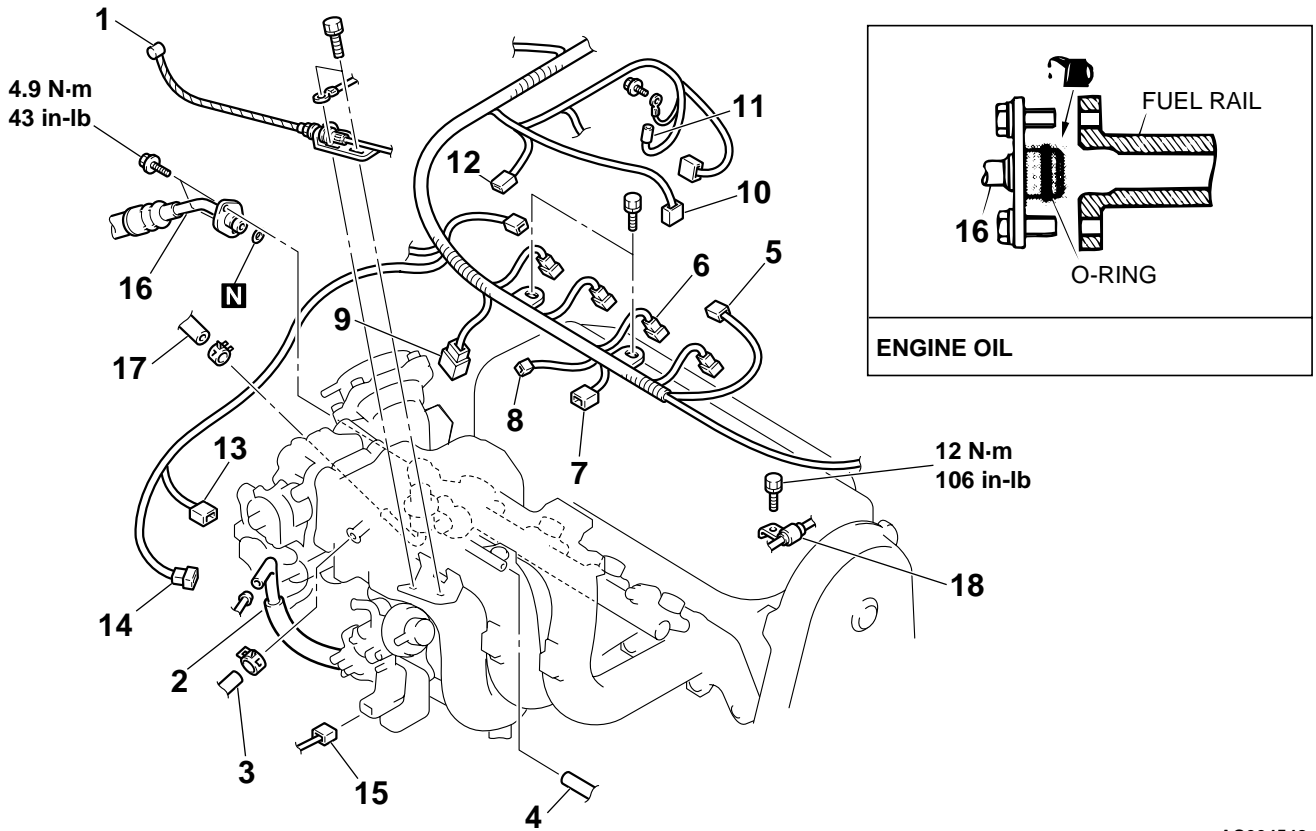

AC004548AB

REMOVAL STEPS

1. ACCELERATOR CABLE CONNECTION
2. PURGE HOSE CONNECTION
3. BRAKE BOOSTER VACUUM HOSE CONNECTION
4. VACUUM HOSE CONNECTION <VEHICLES WITH AUTO-CRUISE CONTROL SYSTEM>
5. IGNITION COIL CONNECTOR
6. INJECTOR CONNECTOR
7. IGNITION FAILURE SENSOR CONNECTOR
8. MANIFOLD DIFFERENTIAL PRESSURE SENSOR CONNECTOR
9. THROTTLE POSITION SENSOR CONNECTOR

>>C<<

REMOVAL STEPS (Continued)

10. HEATED OXYGEN SENSOR (FRONT) CONNECTOR
11. CAPACITOR CONNECTOR
12. CAMSHAFT POSITION SENSOR CONNECTOR
13. IDLE AIR CONTROL MOTOR CONNECTOR
14. EVAPORATIVE EMISSION PURGE SOLENOID VALVE CONNECTOR
15. EGR SOLENOID VALVE CONNECTOR
16. HIGH-PRESSURE FUEL HOSE CONNECTION
17. FUEL RETURN HOSE CONNECTION
18. PRESSURE HOSE CONNECTION

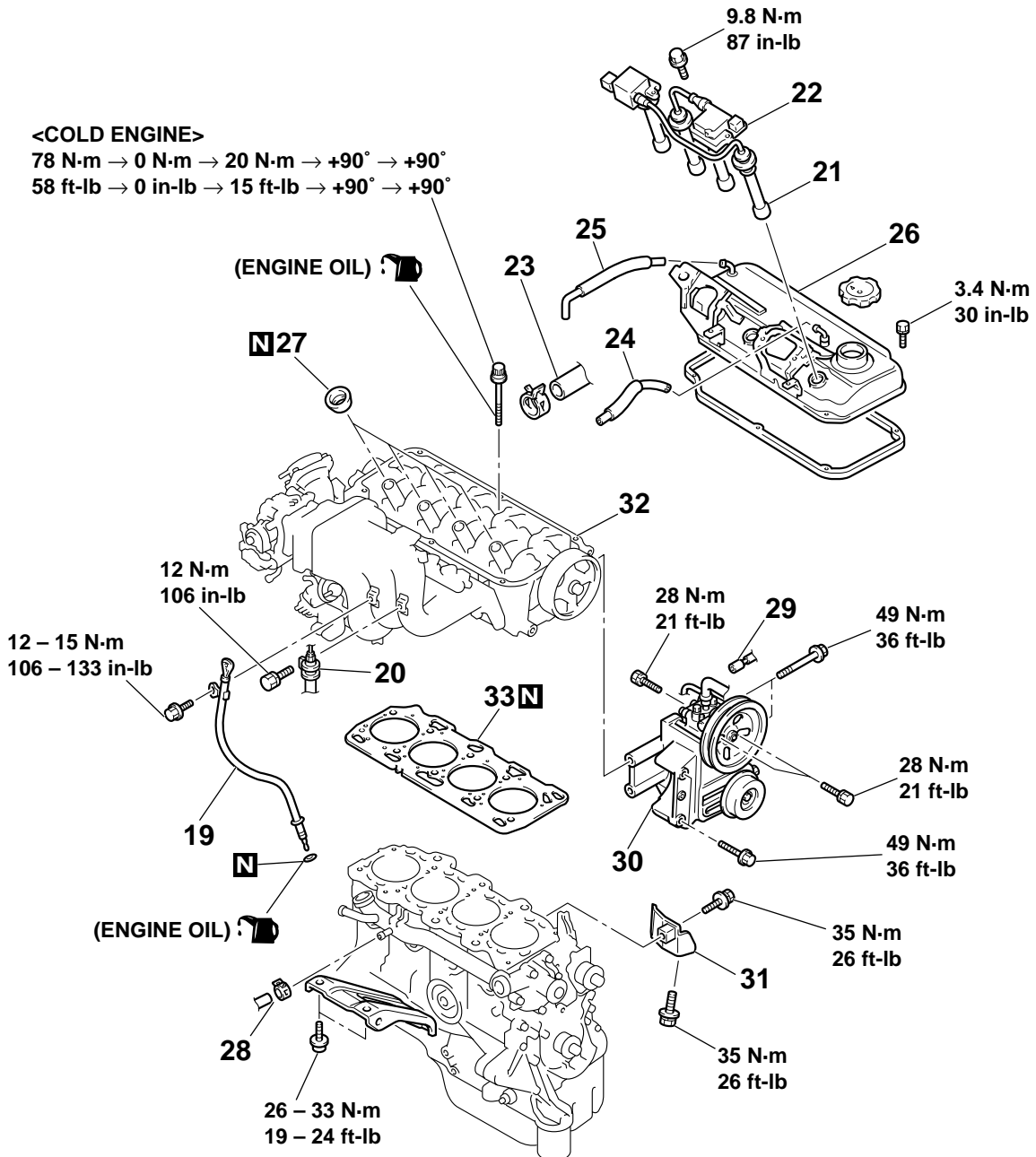

AC001695AC

REMOVAL STEPS

19. OIL DIPSTICK AND DIPSTICK GUIDE
20. PRESSURE HOSE CONNECTION
21. SPARK PLUG CABLE
22. IGNITION COIL
23. RADIATOR UPPER HOSE CONNECTION
24. PCV HOSE CONNECTION
25. BREATHER HOSE CONNECTION
26. ROCKER COVER

<<A>>

<>

>>B<<

>>A<<

REMOVAL STEPS (Continued)

27. SPARK PLUG GUIDE OIL SEAL
28. WATER HOSE CONNECTION
 - TIMING BELT (REFER TO P.11A-30.)
29. POWER STEERING PRESSURE SWITCH
30. POWER STEERING OIL PUMP AND BRACKET ASSEMBLY
31. EXHAUST MANIFOLD BRACKET
32. CYLINDER HEAD ASSEMBLY
33. CYLINDER HEAD GASKET

Required Special Tool:

- MB991654: Cylinder Head Bolt Wrench (12)

TSB Revision

REMOVAL SERVICE POINTS

<<A>> POWER STEERING OIL PUMP AND BRACKET ASSEMBLY REMOVAL

Remove the power steering oil pump and bracket assembly from the engine with the hose attached.

NOTE: Place the removed power steering oil pump in a place where it will not be a hindrance when removing and installing the cylinder head assembly, and secure it with a cord or wire.

<> CYLINDER HEAD ASSEMBLY REMOVAL

⚠ CAUTION

Be careful not to damage or deform the plug guides when removing the cylinder head bolts. Plug guides cannot be replaced separately.

Using special tool MB991654, loosen the bolts in two or three steps in the order of the numbers shown in the illustration, then remove the cylinder head assembly.

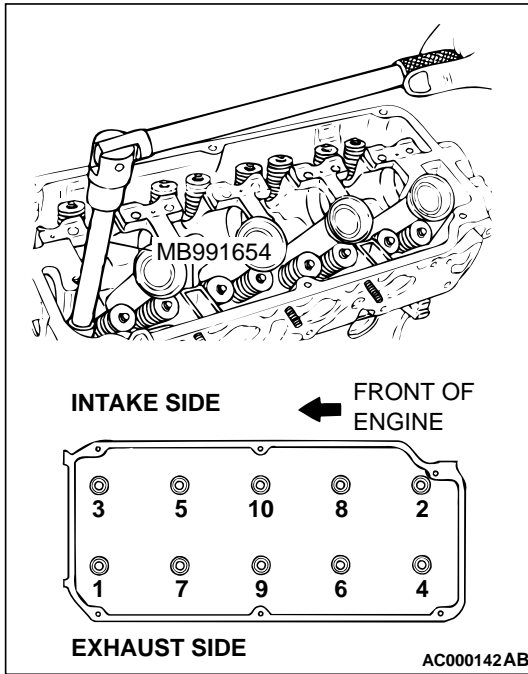

INSTALLATION SERVICE POINTS

>>A<< CYLINDER HEAD GASKET INSTALLATION

1. Wipe off all oil and grease from the gasket mounting surface.
2. Match the shapes of the cylinder head holes with their respective cylinder head gasket holes.

>>B<< CYLINDER HEAD ASSEMBLY INSTALLATION

1. When installing the cylinder head bolts, the length below the head of the bolts should be within the limit. If it is outside the limit, replace the bolts.

Limit (A): 99.4 mm (3.91 inches)

2. Apply a small amount of engine oil to the thread section and the washer of the cylinder head bolt.

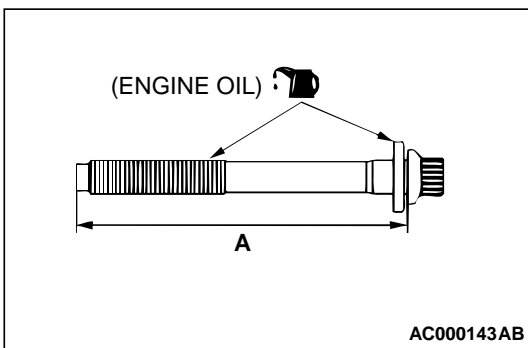

⚠ CAUTION

- Always tighten cylinder head bolts at a 90 degree angle. If it is less than 90 degree angle, the bolt will loosen.
- If it is more than 90 degree angle, remove the head bolt and repeat the procedure from step 1.

3. Using special tool MB991654, tighten the bolts by the following procedure.

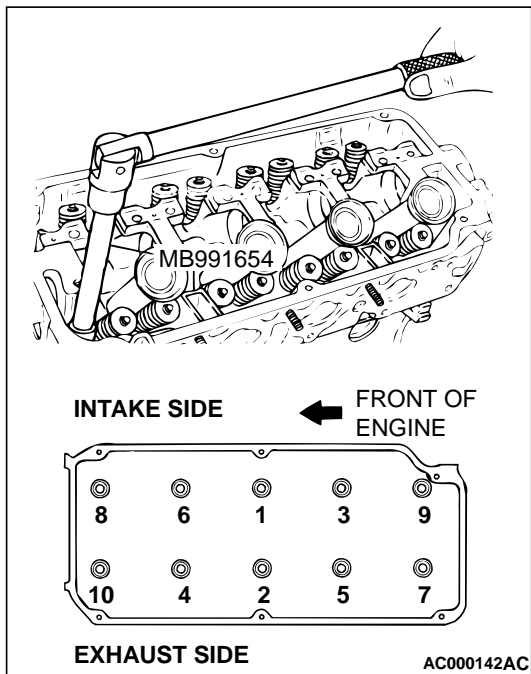

STEP	OPERATION	REMARKS
(1)	Tighten to 78 N·m (58 ft-lb)	Tighten in the order shown in the illustration.
(2)	Fully loosen.	Tighten in the reverse order of that shown in the illustration.
(3)	Tighten to 20 N·m (15 ft-lb)	Tighten in the order shown in the illustration.
(4)	Tighten 90° of a turn.	Tighten in the order shown in the illustration. Mark the head of the cylinder head bolt and cylinder head with a paint mark.
(5)	Tighten 90° of a turn.	Tighten in the order shown in the illustration. Check that the painted mark of the head bolt is aligned with that of the cylinder head.

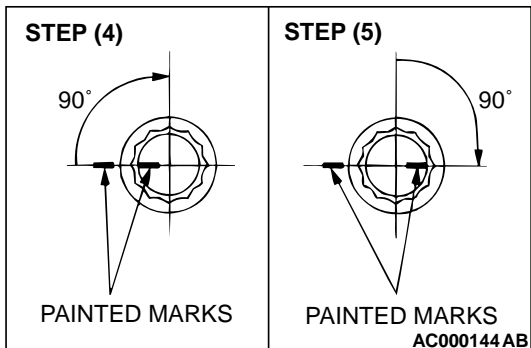

>>C<< HIGH-PRESSURE FUEL HOSE INSTALLATION

⚠ CAUTION

Do not allow engine oil to enter the fuel rail.

1. Apply a small amount of new engine oil to the O-ring.
2. While turning the high-pressure fuel hose to the right and left, install the fuel rail, while being careful not to damage the O-ring. After installing, check that the hose turns smoothly.
3. If the hose does not turn smoothly, the O-ring is probably being clamped. Disconnect the high-pressure fuel hose and check the O-ring for damage.
4. Re-insert the fuel rail and confirm the hose turns smoothly.

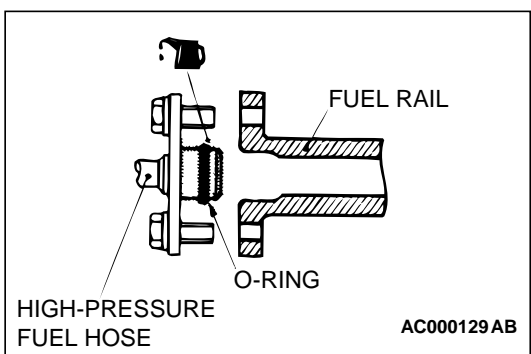

TIMING BELT

REMOVAL AND INSTALLATION

M1112004300106

<p>Pre-removal Operation</p> <ul style="list-style-type: none"> Engine Mount Bracket Removal (Refer to GROUP 32, Engine Mounting P.32-5.) 	<p>Post-installation Operation</p> <ul style="list-style-type: none"> Engine Mount Bracket Installation (Refer to GROUP 32, Engine Mounting P.32-5.) Drive Belt Tension Adjustment [Refer to GROUP 00, Maintenance Service – Drive Belts (Check Condition) P.00-39.]
---	---

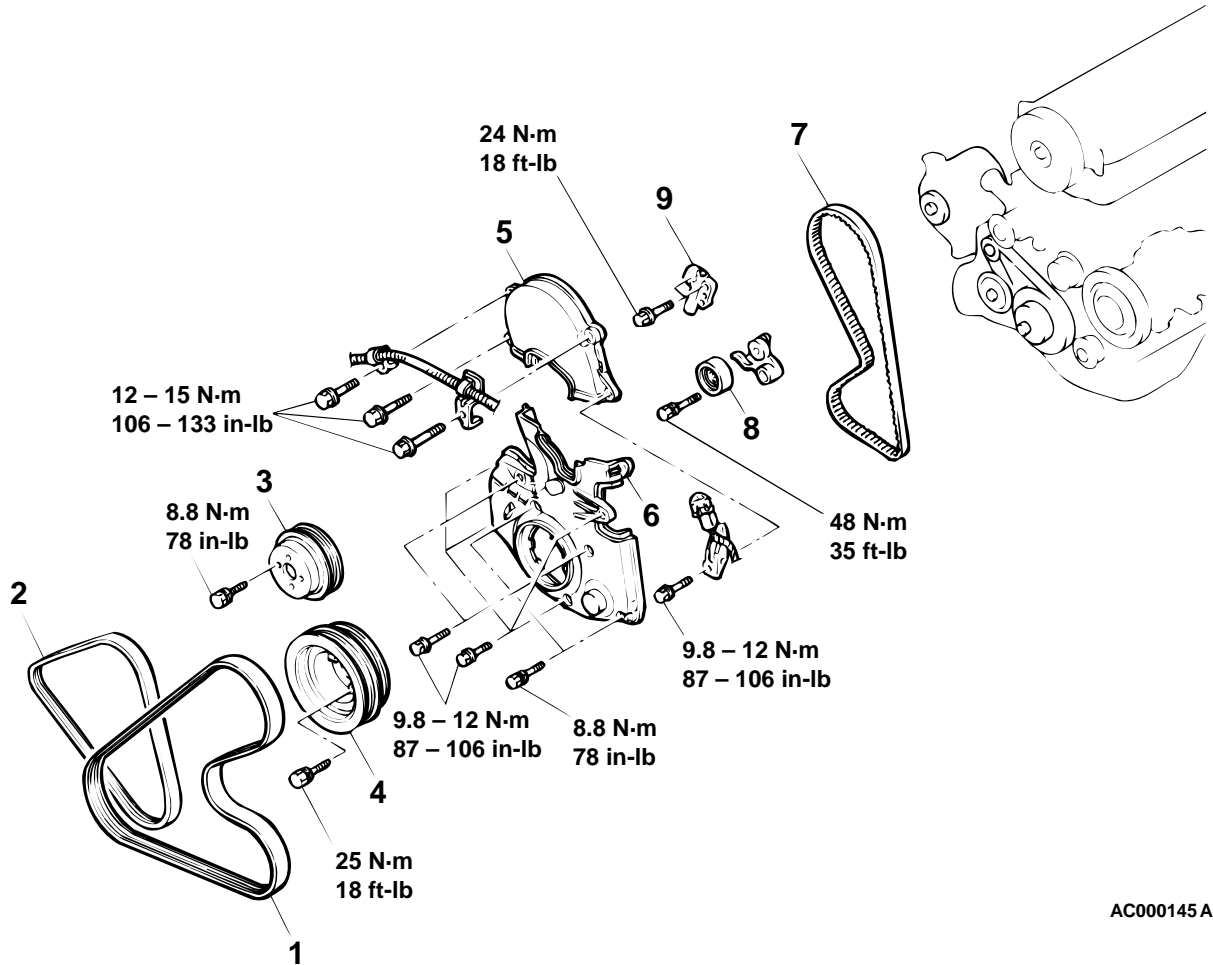

AC000145AC

REMOVAL STEPS

1. DRIVE BELT (POWER STEERING OIL PUMP AND A/C COMPRESSOR)
2. DRIVE BELT (GENERATOR)
3. WATER PUMP PULLEY
4. CRANKSHAFT PULLEY
5. TIMING BELT UPPER COVER ASSEMBLY

REMOVAL STEPS (Continued)

6. TIMING BELT LOWER COVER ASSEMBLY
 7. TIMING BELT
 8. TENSIONER PULLEY
 9. AUTO-TENSIONER
- >>C<<
- <<A>> >>B<<
- >>A<<

Required Special Tools:

- MD998738: Adjusting Screw

- MD998767: Tensioner Wrench

TSB Revision

REMOVAL SERVICE POINT

<<A>> TIMING BELT REMOVAL

⚠ CAUTION

The crankshaft should always be turned in the forward direction only.

1. Turn the crankshaft in the forward direction (to the right) to align the camshaft sprocket timing marks.

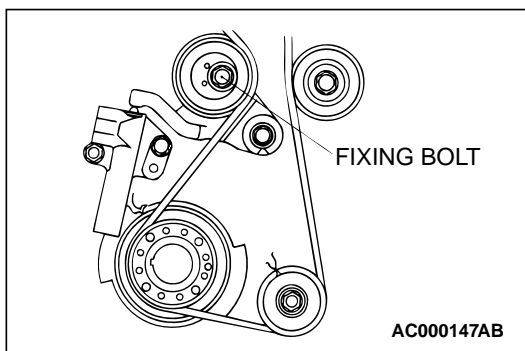
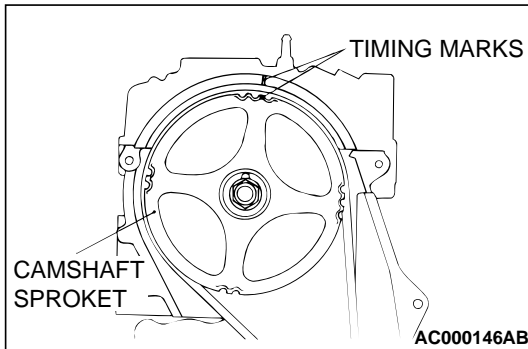

2. Loosen the tension pulley fixing bolt.

⚠ CAUTION

If the timing belt is to be re-used, use chalk to mark (on its flat side) an arrow indicating the clockwise direction.

3. Move the tension pulley to the water pump side, and then remove the timing belt.

INSTALLATION SERVICE POINTS

>>A<< AUTO-TENSIONER INSTALLATION

1. Apply 98 – 196 N (22 – 44 pound) force to the pushrod of the auto-tensioner by pressing it against a metal object (such as the engine block) and measure the movement of the pushrod.

Standard value: Within 1 mm (0.04 inch)

A: Length when it is free (not pressed)

B: Length when it is pressed

A – B: Movement

2. If it is outside the standard value, replace the auto-tensioner.

⚠ CAUTION

Never compress the pushrod too fast, or it may be damaged.

3. Use a press or vise to gently compress the auto-tensioner pushrod until pin hole A of the pushrod and pin hole B of the tensioner cylinder are aligned.

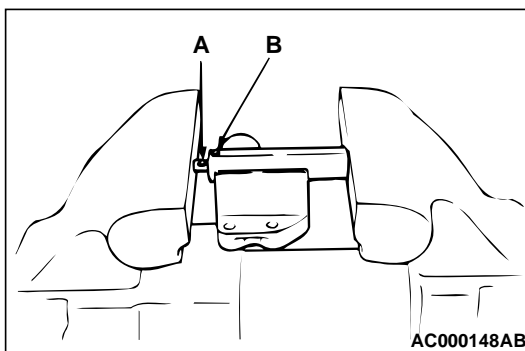
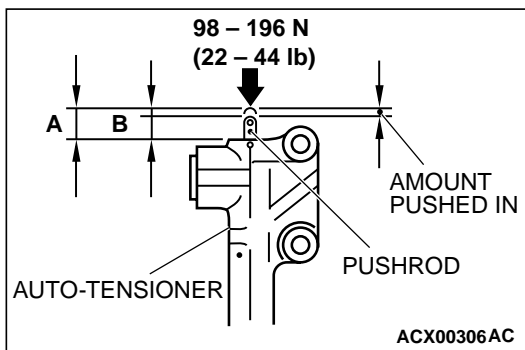

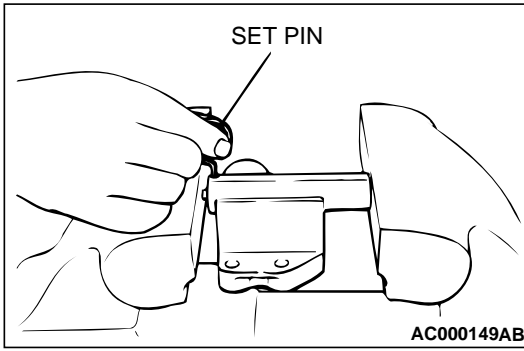

4. When the holes are aligned, insert the set pin.
NOTE: When replacing the auto-tensioner with a new part, the pin will be in the auto-tensioner.
5. Install the auto-tensioner to the engine.

>>B<< TIMING BELT INSTALLATION

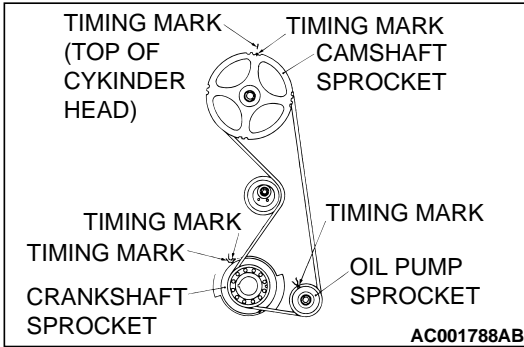

1. Align the timing marks on the camshaft sprocket, crankshaft sprocket and oil pump sprocket.

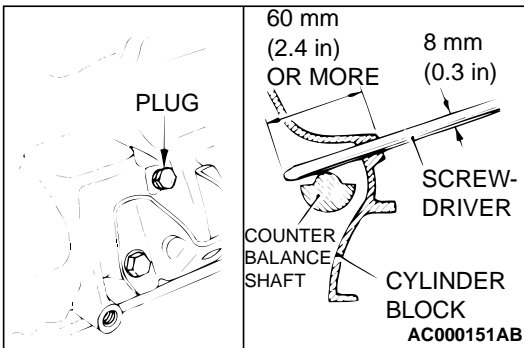

2. After aligning the timing mark on the oil pump sprocket, remove the cylinder block plug and insert a Phillips head 8 mm (0.3 inch) screwdriver. Check to be sure that the screwdriver goes in 60 mm (2.4 inches) or more. If the screwdriver will only go in 20 – 25 mm (0.8 – 1.0 inch) before striking the counterbalance shaft, turn the sprocket once, realign the timing marks and check that the screwdriver goes in 60 mm (2.4 inches) or more. The screwdriver should not be taken out until the timing belt is installed.

CAUTION

If the timing belt is re-used, install so that the arrow marked on it at time of removal is pointing in the clockwise direction.

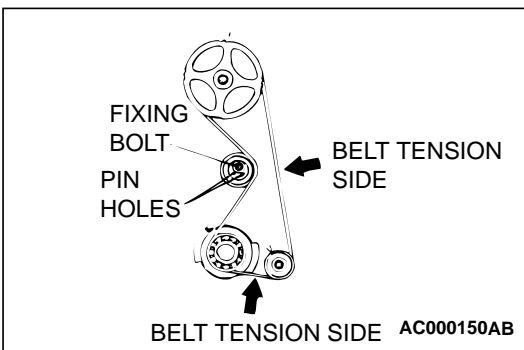

3. Install the belt to the crankshaft sprocket, oil pump sprocket and camshaft sprocket in that order, so that there is no slackness in the belt tension.
4. Set the tension pulley so that the pin holes are at the bottom, press the tension pulley lightly against the timing belt, and then provisionally tighten the fixing bolt.
5. Adjust the timing belt tension.

>>C<< TIMING BELT TENSION ADJUSTMENT

⚠ CAUTION

Do not use a spanner or the similar tool to turn special tool MD998738. Otherwise, the auto-tensioner set pin may be broken. Turn special tool MD998738 by hand only.

1. Remove the rubber plug from the rear of the timing belt cover assembly. Then screw in special tool MD998738 by hand until the tensioner arm is touching the auto-tensioner pushrod.
2. After turning the crankshaft 1/4 of a revolution in the anticlockwise direction, turn it in the clockwise direction until the timing marks are aligned.

⚠ CAUTION

When tightening the fixing bolt, make sure that the tension pulley does not turn with the bolt.

3. Loosen the tension pulley fixing bolt, and then use special tool MD998767 and a torque wrench to tighten the fixing bolt to the specified torque while applying tension to the timing belt.

Timing belt tension torque: 3.5 N·m (31 in·lb)

Tightening torque: 48 N·m (35 ft·lb)

4. Remove the set pin that has been inserted into the auto-tensioner, and then remove special tool MD998767.

5. Turn the crankshaft two revolutions clockwise so that the timing marks are aligned. After leaving it for 15 minutes, measure the amount of protrusion of the auto-tensioner.

Standard value (A): 3.8 – 4.5 mm (0.15 – 0.18 inch)

6. If the amount of protrusion is outside the standard value, repeat steps (1) through (5).

7. Check again to be sure that the timing marks of each sprocket are aligned.

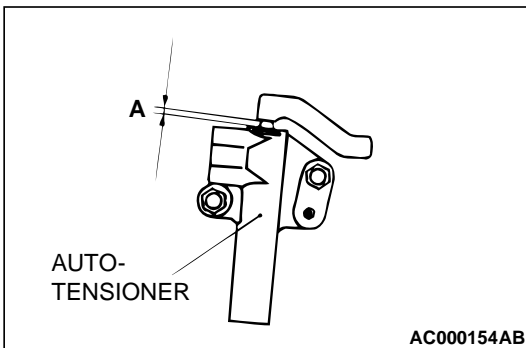
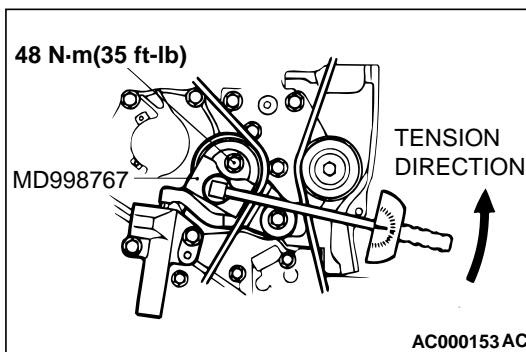
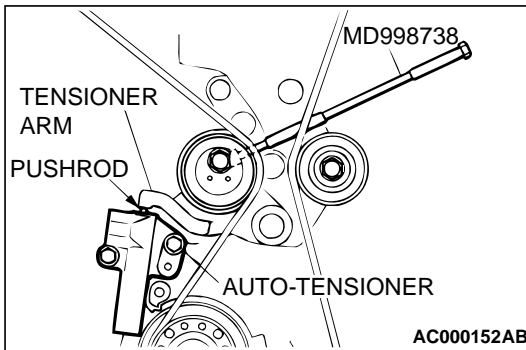

TIMING BELT B

REMOVAL AND INSTALLATION

M1112004600044

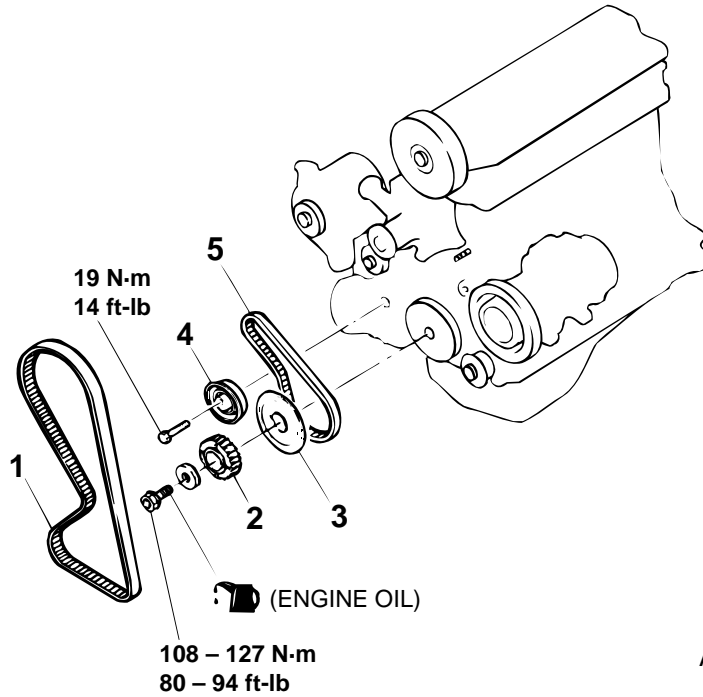

AC000155 AC

REMOVAL STEPS

1. TIMING BELT (REFER TO P.11A-30.)
- >>C<< • TIMING BELT B TENSION ADJUSTMENT

<<A>> >>B<<
>>B<<
<> >>A<<

REMOVAL STEPS (Continued)

2. CRANKSHAFT SPROCKET
3. CRANKSHAFT SENSING BLADE
4. TIMING BELT B TENSIONER
5. TIMING BELT B

Required Special Tool:

- MB991367: Special Spanner

REMOVAL SERVICE POINTS

<<A>> CRANKSHAFT SPROCKET REMOVAL

1. Use the crankshaft pulley mounting bolt to hold special tool MB991367.
2. Loosen the crankshaft sprocket mounting bolt, and remove the sprocket.

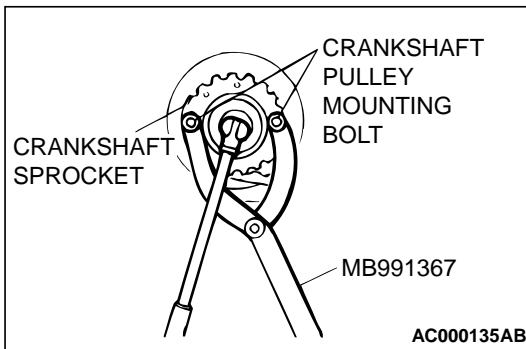

<> TIMING BELT B REMOVAL

⚠ CAUTION

If the belt is to be re-used, mark an arrow on the belt with chalk indicating the clockwise direction of rotation.

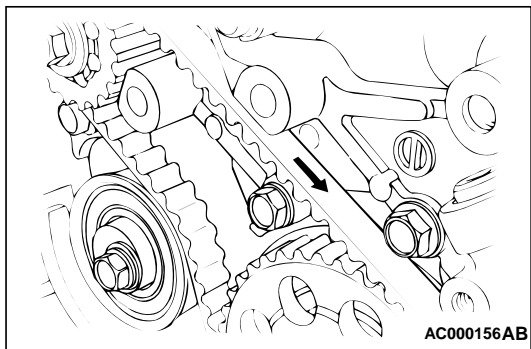

INSTALLATION SERVICE POINTS

>>A<< TIMING BELT B INSTALLATION

1. Ensure that crankshaft sprocket B timing marks and the counterbalance shaft sprocket timing marks are aligned.
2. Fit timing belt B over crankshaft sprocket B and the counterbalance shaft sprocket. Ensure that there is no slack in the belt.

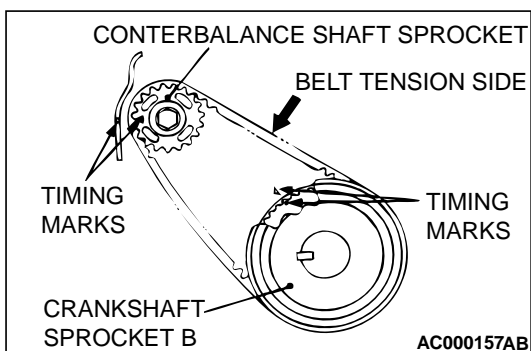

>>B<< CRANKSHAFT SENSING BLADE/CRANKSHAFT SPROCKET INSTALLATION

1. To prevent the crankshaft bolt from loosening, degrease or clean the seating surfaces of the crankshaft, crankshaft sprocket B, crankshaft sensing blade and crankshaft at the shown positions.
2. Install the crankshaft sensing blade so that they face as shown in the illustration.
3. Apply the minimum amount of engine oil to the seat surface and thread of the crankshaft bolt.

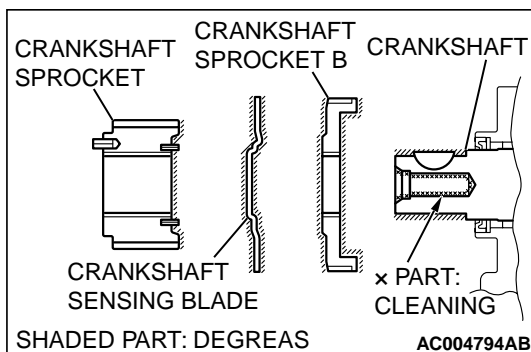

4. Use the crankshaft pulley mounting bolt to secure special tool MB991367.
5. Tighten the crankshaft sprocket bolt to the specified torque.

Tightening torque: 108 – 127 N·m (80 – 94 ft-lb)

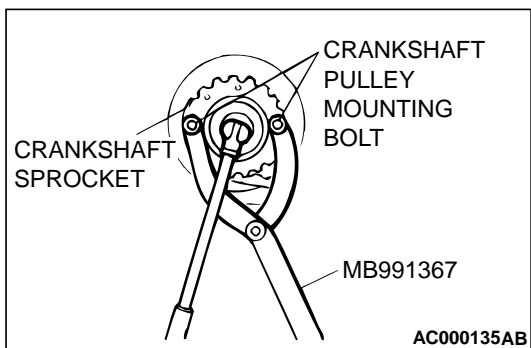

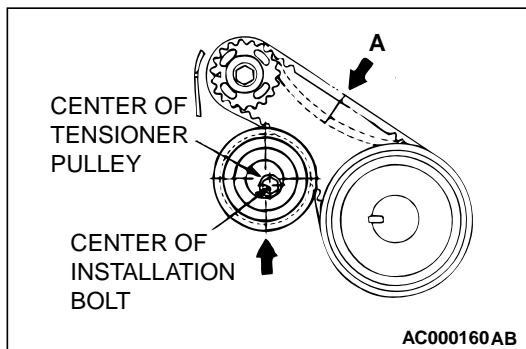
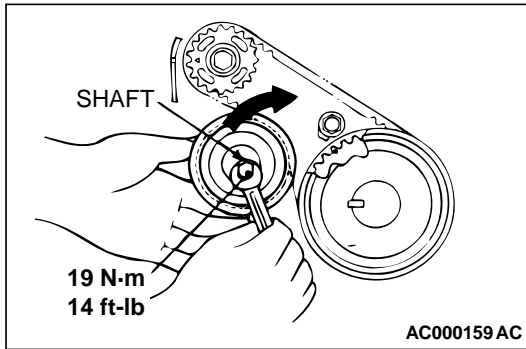
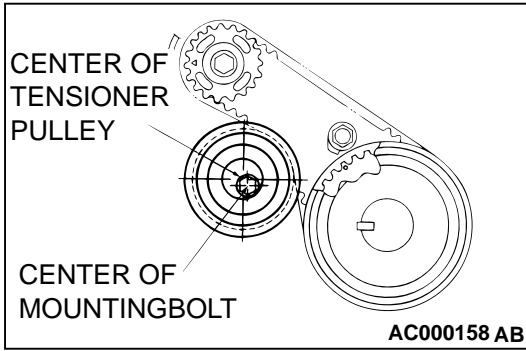

>>C<< TIMING BELT B TENSION ADJUSTMENT

1. Temporarily fix the timing belt B tensioner so the center of the tensioner pulley is to the left and above the center of the mounting bolt. Temporarily attach the tensioner pulley so the flange is toward the front of the engine.

CAUTION

When tightening the bolt, ensure that the tensioner pulley shaft does not rotate with the bolt. Allowing it to rotate with the bolt can cause excessive tension of the bolt.

2. Holding the timing belt B tensioner up with your finger in the direction of the arrow, apply pressure on the timing belt so the tension side of the belt is taut. Now tighten the bolt to fix the tensioner.

Tightening torque: 19 N·m (14 ft·lb)

3. To ensure that the tension is correct, depress the belt (point A) with a finger. Adjust the belt tension if it is incorrect.

Standard value: 5 – 7 mm (0.2 – 0.3 inch)

SPECIFICATIONS

FASTENER TIGHTENING SPECIFICATIONS

M1111003800116

ITEMS	SPECIFICATIONS
Auto-tensioner attaching bolt	24 N·m (18 ft·lb)
Bell housing cover attaching bolt (bolt, flange)	25 N·m (18 ft·lb)
Bell housing cover attaching bolt (bolt, washer assembled))	8.8 N·m (78 in·lb)
Camshaft position sensor sensing cylinder attaching bolt	22 N·m (16 ft·lb)
Camshaft position sensor support attaching bolt	14 N·m (124 in·lb)
Camshaft sprocket attaching bolt	88 N·m (65 ft·lb)
Crankshaft pulley attaching bolt	25 N·m (18 ft·lb)
Crankshaft sprocket attaching bolt	108 – 127 N·m (80 – 94 ft·lb)

TSB Revision

ITEMS		SPECIFICATIONS
Cylinder head attaching bolt		78 N·m → 0 N·m → 20 N·m → +90° → +90° (58 ft-lb → 0 ft-lb → 15 ft-lb → +90° → +90°)
Drive plate attaching bolt		127 – 137 N·m (94 – 101 ft-lb)
Engine mount bracket attaching bolt	M12 × 74	86 N·m (63 ft-lb)
	M12 × 108	81 N·m (60 ft-lb)
Engine mount bracket attaching nut		86 N·m (63 ft-lb)
Exhaust manifold bracket attaching bolt		35 N·m (26 ft-lb)
High-pressure fuel hose attaching bolt		4.9 N·m (43 in-lb)
Ignition coil attaching bolt		9.8 N·m (87 in-lb)
Intake manifold stay attaching bolt		26 – 33 N·m (19 – 24 ft-lb)
Oil dipstick guide attaching bolt		12 – 15 N·m (106 – 133 in-lb)
Oil pan attaching bolt		6.9 N·m (61 in-lb)
Oil pan drain plug		39 N·m (29 ft-lb)
Power steering oil pump attaching bolt		28 N·m (21 ft-lb)
Power steering oil pump bracket attaching bolt		49 N·m (36 ft-lb)
Pressure hose attaching bolt		12 N·m (106 in-lb)
Pressure tube attaching bolt		12 N·m (106 in-lb)
Rocker arm and shaft assembly attaching bolt		28 – 34 N·m (21 – 25 ft-lb)
Rocker cover attaching bolt		3.4 N·m (30 in-lb)
Tensioner pulley attaching bolt		48 N·m (35 ft-lb)
Timing belt B tensioner attaching bolt		19 N·m (14 ft-lb)
Timing belt lower cover attaching bolt (bolt, flange)		9.8 – 12 N·m (87 – 106 in-lb)
Timing belt lower cover attaching bolt (bolt, washer assembly)		8.8 N·m (78 in-lb)
Timing belt upper cover attaching bolt	M6	9.8 – 12 N·m (87 – 106 in-lb)
	M8	12 – 15 N·m (106 – 133 in-lb)
Water pump pulley attaching bolt		8.8 N·m (78 in-lb)

SERVICE SPECIFICATIONS

M1111000300134

ITEMS	STANDARD VALUE	LIMIT
Basic ignition timing at idle	5° BTDC ± 3°	–
Actual ignition timing at idle	Approximately 10° BTDC	–
CO content%	0.5 or less	–
HC contents ppm	100 or less	–
Curb idle speed r/min	700 ± 100	–
Compression pressure (250 – 400 r/min) kPa (psi)	1,275 (185)	Minimum 959 (139)
Compression pressure difference of all cylinder kPa (psi)	–	98 (14)
Intake manifold vacuum at curb idle kPa (in Hg)	–	Minimum 60 (18)
Cylinder head bolt shank length mm (in)	–	99.4 (3.91)

TSB Revision

11A-38

ENGINE MECHANICAL <2.4L> SPECIFICATIONS

ITEMS	STANDARD VALUE	LIMIT
Auto-tensioner pushrod movement mm (in)	Within 1 (0.04)	–
Auto-tensioner rod protrusion mm (in)	3.8 – 4.5 (0.15 – 0.18)	–
Timing belt B tension mm (in)	5 – 7 (0.2 – 0.3)	–

SEALANTS AND ADHESIVES

M1111000500116

ITEM	SPECIFIED SEALANT
Camshaft position sensor support and oil pan	mitsubishi GENUINE Sealant Part No. MD970389 or equivalent

TSB Revision