

GROUP 11D

ENGINE OVERHAUL







<3.0L>

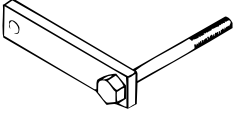
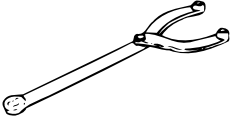
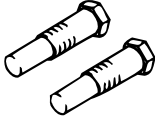

CONTENTS

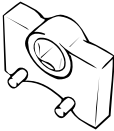
SPECIAL TOOLS	11D-2	REMOVAL AND INSTALLATION	11D-22
		INSPECTION	11D-25
GENERATOR AND DRIVE BELT ...	11D-4	CYLINDER HEAD AND VALVES	11D-28
REMOVAL AND INSTALLATION	11D-4	REMOVAL AND INSTALLATION	11D-28
INTAKE MANIFOLD PLENUM AND THROTTLE BODY ASSEMBLY	11D-6	INSPECTION	11D-31
REMOVAL AND INSTALLATION	11D-6	OIL PAN AND OIL PUMP	11D-35
IGNITION SYSTEM	11D-8	REMOVAL AND INSTALLATION	11D-35
REMOVAL AND INSTALLATION	11D-8	INSPECTION	11D-41
TIMING BELT	11D-10	PISTON AND CONNECTING ROD ..	11D-42
REMOVAL AND INSTALLATION	11D-10	REMOVAL AND INSTALLATION	11D-42
INSPECTION	11D-15	INSPECTION	11D-48
INTAKE MANIFOLD AND FUEL PARTS		CRANKSHAFT AND CYLINDER BLOCK	
.....	11D-17	11D-50
REMOVAL AND INSTALLATION	11D-17	REMOVAL AND INSTALLATION	11D-50
WATER PUMP & WATER HOSE ...	11D-19	INSPECTION	11D-54
REMOVAL AND INSTALLATION	11D-19	SPECIFICATIONS	11D-56
EXHAUST MANIFOLD	11D-21	FASTENER TIGHTENING SPECIFICATIONS	
REMOVAL AND INSTALLATION	11D-21	11D-56
ROCKER ARMS AND CAMSHAFT ..	11D-22	GENERAL SPECIFICATIONS	11D-58
		SERVICE SPECIFICATIONS	11D-58
		SEALANTS AND ADHESIVES	11D-60

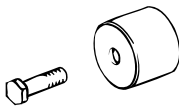
SPECIAL TOOLS

M1113000600045

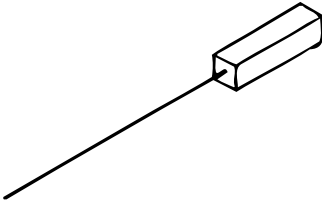
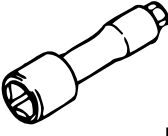
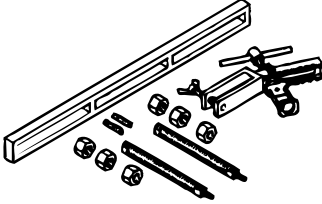
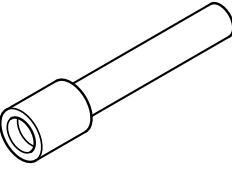
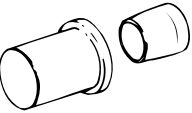
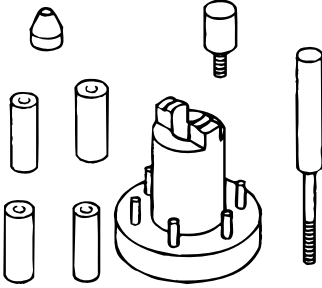
TOOL	TOOL NUMBER AND NAME	SUPERSESSION	APPLICATION
 D998781	MD998781 Flywheel stopper	General service tool	Loosening and tightening crankshaft bolts
 MB990767	MB990767 End yoke holder	MB990767-01	Holding camshaft sprocket when loosening or torquing bolt.
 D998715	MD998715 Pins	MIT308239	
 D998769	MD998769 Crankshaft spacer	General service tool	Rotation of crankshaft when installing piston and timing belt
 D998767	MD998767 Tension pulley wrench	MD998752-01	Adjustment of timing belt tension
 D998443	MD998443 Lash adjuster holder (8)	MD998443-01	Supporting lash adjuster to prevent it from falling when rocker shaft assembly is removed or installed
 D998713	MD998713 Camshaft oil seal installer	MD998713-01	Installation of camshaft oil seal
 B991559	MB991559 Camshaft oil seal installer adaptor<left bank side>	General service tool	

TOOL	TOOL NUMBER AND NAME	SUPERSESION	APPLICATION
	MD998442 Air bleed wire	General service tool	Air bleeding of lash adjuster
 <p align="center">D998051</p>	MD998051 Cylinder head bolt wrench	MD998051-01 or General service tool	Loosening and tightening cylinder head bolts
	MD998772 Valve spring compressor	General service tool	Compression of valve spring
	MD998774 Valve stem seal installer	MD998774-01	Installation of valve stem seal
 <p align="center">D998717</p>	MD998717 Crankshaft front oil seal installer	MD998717-01	Installation of crankshaft front oil seal
	MD998780 Piston pin setting tool	MIT216941	Removal and installation of piston pin
 <p align="center">D998718</p>	MD998718 Crankshaft rear oil seal installer	MD998718-01 Use with MB990938-01	Installation of crankshaft rear oil seal

GENERATOR AND DRIVE BELT

REMOVAL AND INSTALLATION

M1113001300092

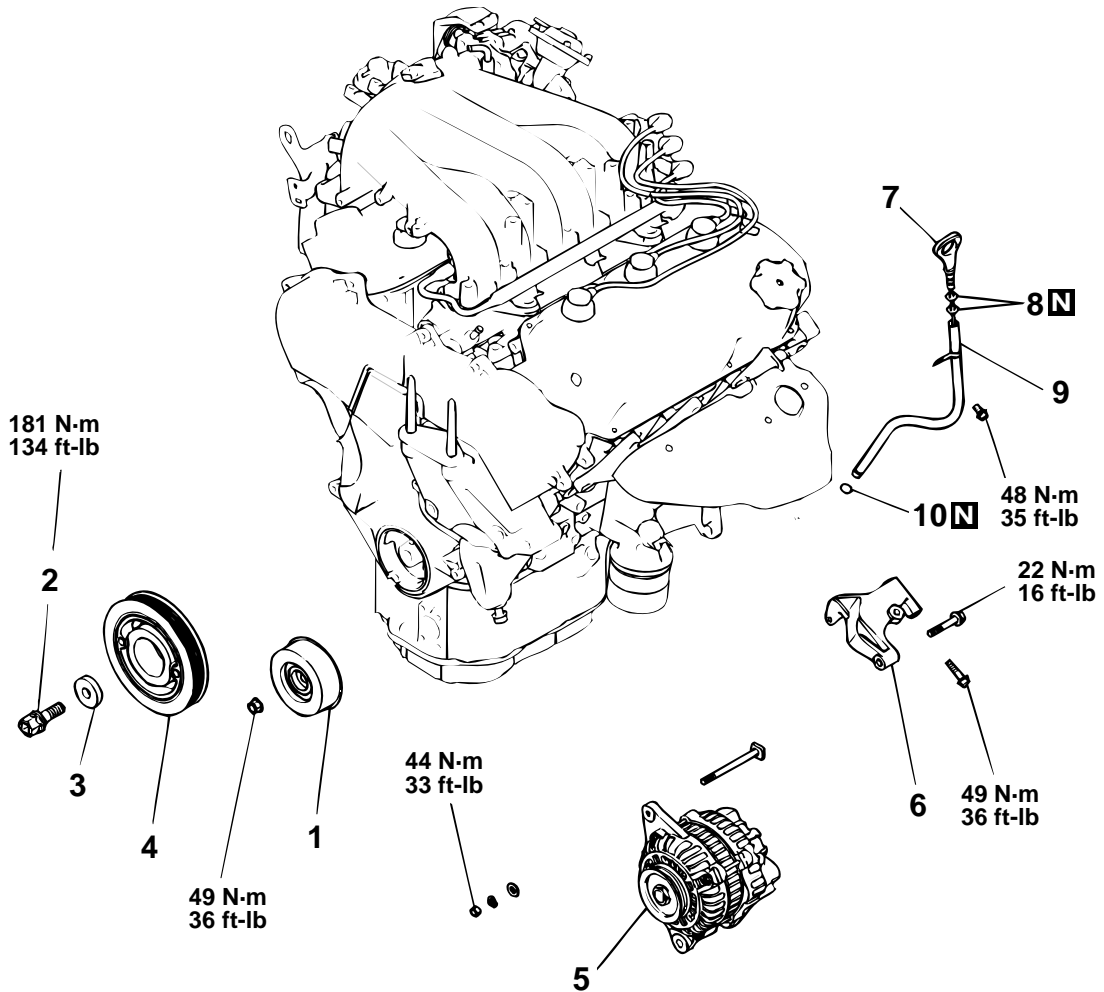

AKX00661AD

REMOVAL STEPS

<<A>> >>A<<

1. DRIVE BELT TENSIONER
2. CRANKSHAFT BOLT
3. CRANKSHAFT PULLEY WASHER
4. DAMPER PULLEY
5. GENERATOR

REMOVAL STEPS (Continued)

6. GENERATOR BRACKET
7. OIL DIPSTICK
8. O-RING
9. OIL DIPSTICK GUIDE
10. O-RING

Required Special Tool:

MD998781: Flywheel Stopper

REMOVAL SERVICE POINT

<<A>> CRANKSHAFT BOLT LOOSENING

1. Install special tool MD998781 to hold the drive plate.
2. Loosen and remove the crankshaft bolt and washer.

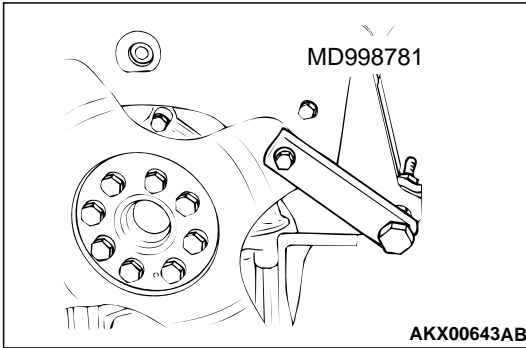

INSTALLATION SERVICE POINT

>>A<< CRANKSHAFT BOLT TIGHTENING

1. Install special tool MD998781 to hold the drive plate.
2. Install the washer and crankshaft bolt, and then tighten the bolt.

Tightening torque: 181 N·m (134 ft-lb)

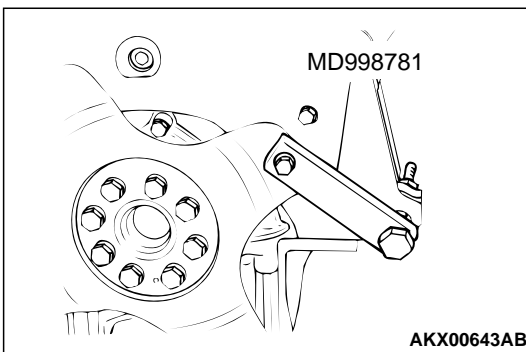

INTAKE MANIFOLD PLENUM AND THROTTLE BODY ASSEMBLY

REMOVAL AND INSTALLATION

M1113003300087

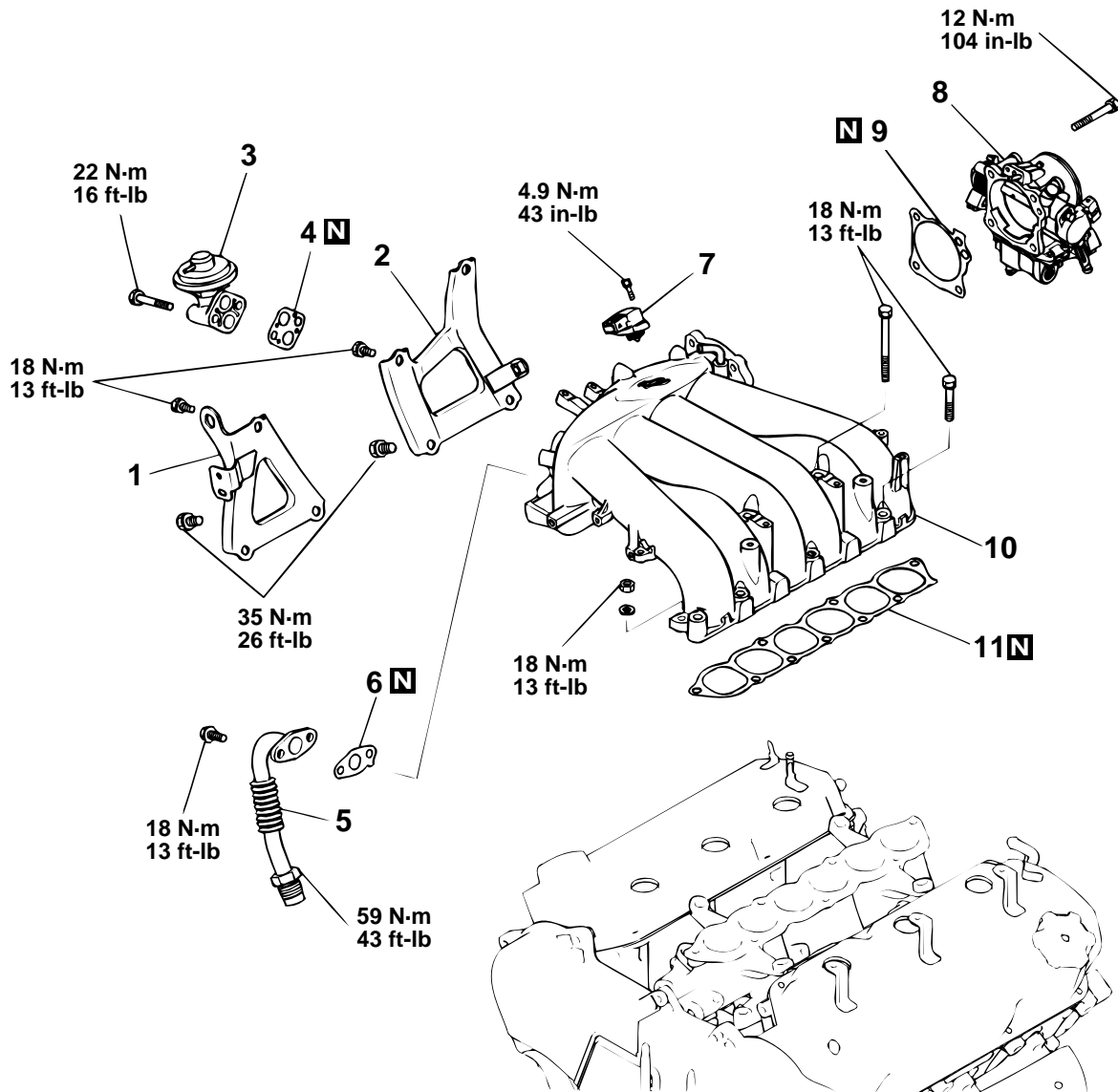

AKX00662AD

REMOVAL STEPS

1. INTAKE MANIFOLD PLENUM STAY, FRONT
2. INTAKE MANIFOLD PLENUM STAY, REAR
3. EGR VALVE
4. EGR VALVE GASKET
5. EGR PIPE

REMOVAL STEPS (Continued)

6. EGR PIPE GASKET
7. MANIFOLD DIFFERENTIAL PRESSURE SENSOR
8. THROTTLE BODY
- >>A<< 9. THROTTLE BODY GASKET
10. INTAKE MANIFOLD PLENUM
11. INTAKE MANIFOLD PLENUM GASKET

TSB Revision

INSTALLATION SERVICE POINT

>>A<< THROTTLE BODY GASKET INSTALLATION

Install the gasket so that the tab is positioned as shown in the illustration.

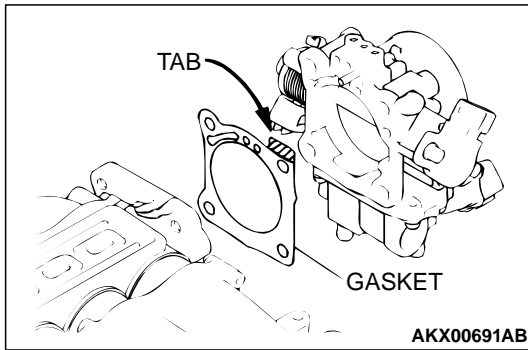

IGNITION SYSTEM

REMOVAL AND INSTALLATION

M1113001600071

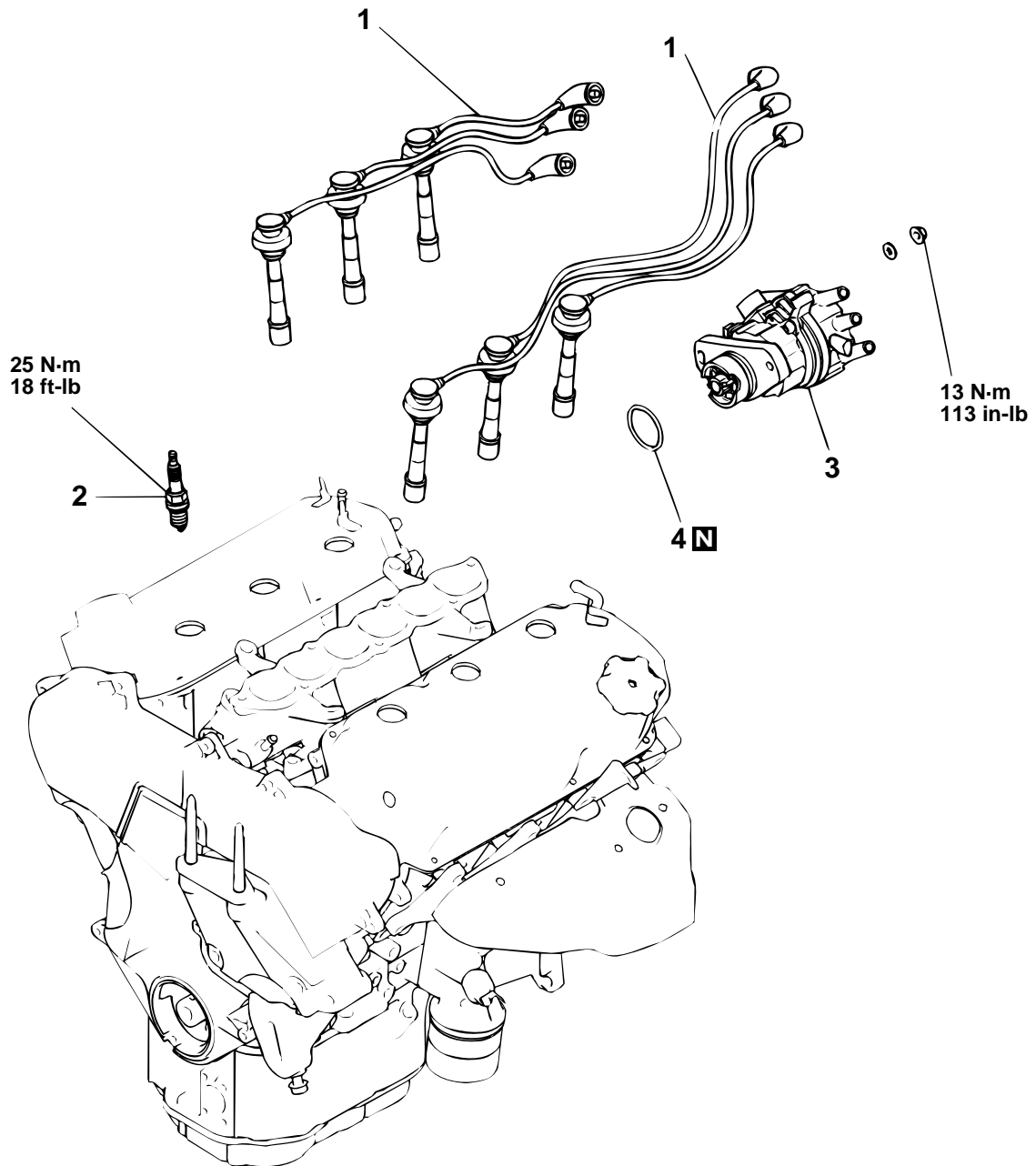

AKX00663AD

REMOVAL STEPS

1. SPARK PLUG CABLES
2. SPARK PLUGS
3. DISTRIBUTOR
4. O-RING

>>A<<

INSTALLATION SERVICE POINT**>>A<< DISTRIBUTOR INSTALLATION**

1. Turn the crankshaft to bring the piston in No.1 cylinder to the top dead center on the compression stroke.

TSB Revision

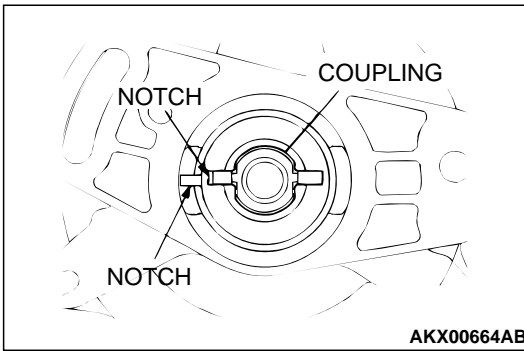

2. Rotate the distributor shaft coupling until its notch (mating mark) is lined up with the notch (mating mark) in the housing.

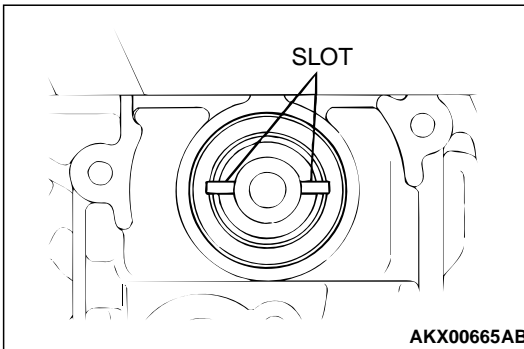

3. Fit the distributor coupling in the slot at the rear end of the camshaft to install the distributor.

TIMING BELT

REMOVAL AND INSTALLATION

M1113001900135

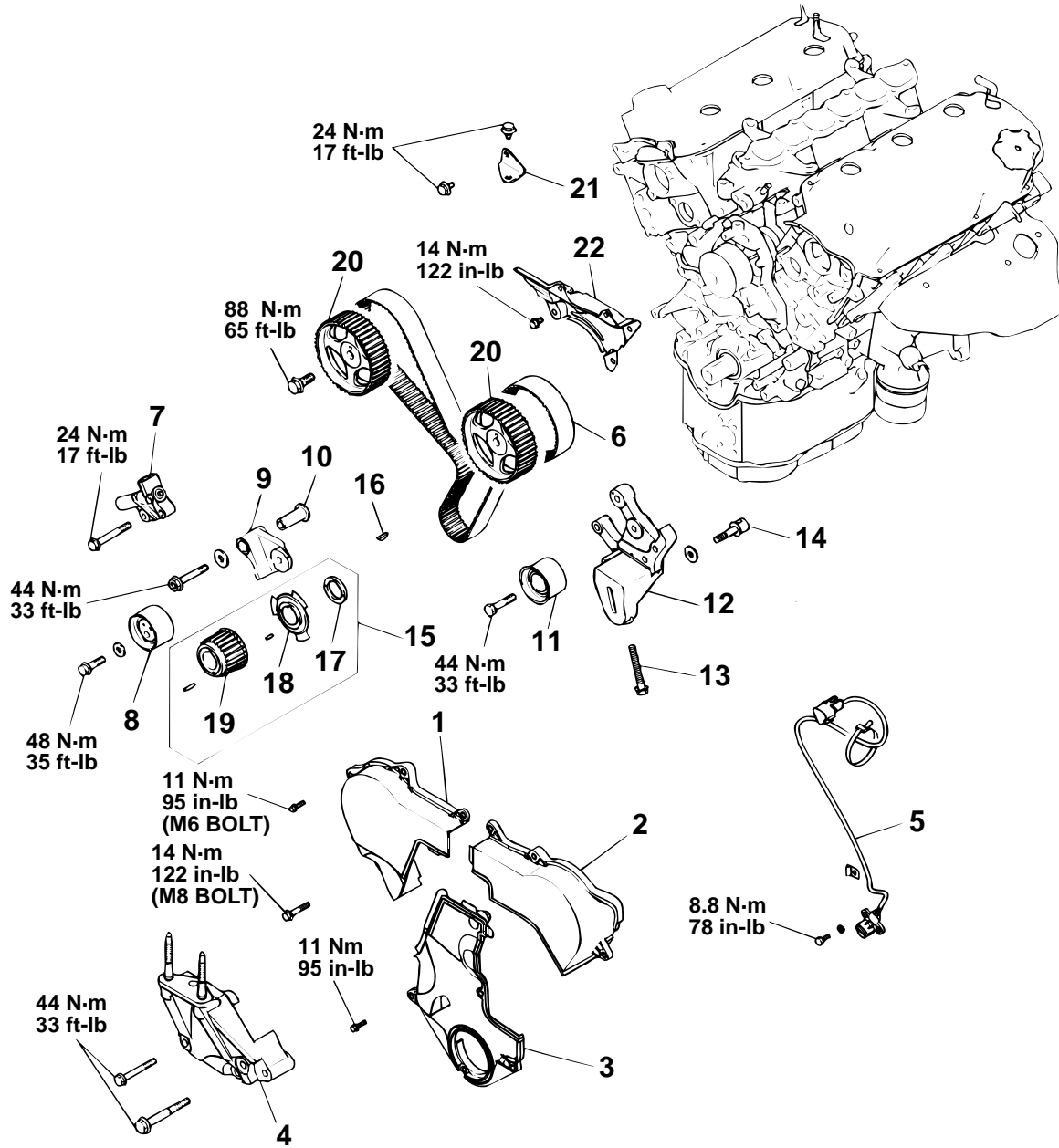

AKX00666AC

REMOVAL STEPS

- 1. TIMING BELT FRONT UPPER COVER, RIGHT
- 2. TIMING BELT FRONT UPPER COVER, LEFT
- 3. TIMING BELT FRONT LOWER COVER
- >>D<< 4. ENGINE SUPPORT BRACKET, RIGHT
- 5. CRANKSHAFT POSITION SENSOR
- <<A>> >>C<< 6. TIMING BELT

REMOVAL STEPS (Continued)

- >>B<< 7. AUTO-TENSIONER
- 8. TENSIONER PULLEY
- 9. TENSIONER ARM
- 10. SHAFT
- 11. IDLER PULLEY
- 12. TENSIONER BRACKET
- 13. ADJUSTING BOLT
- 14. ADJUSTING STUD
- 15. CRANKSHAFT SPROCKET AND SENSING BLADE
- 16. KEY

TSB Revision

REMOVAL STEPS (Continued)

- 17. CRANKSHAFT SPACER
- 18. CRANKSHAFT SENSING BLADE
- 19. CRANKSHAFT SPROCKET
- <> >>B<< 20. CAMSHAFT SPROCKET
- 21. BRACKET
- 22. TIMING BELT REAR COVER

Required Special Tools:

- MB990767: End Yoke Holder
- MD998715: Pins

MD998767: Tensioner Pulley Wrench

MD998769: Crankshaft Spacer

REMOVAL SERVICE POINTS

<<A>> TIMING BELT REMOVAL

CAUTION

Water or oil on the belt shortens its life drastically, so the removed timing belt, sprocket, and tensioner must be kept free from oil and water. These parts should not be washed or immersed in solvent. Replace parts if contaminated. If there is oil or water on any part, check the front case oil seal, camshaft oil seal, and water pump for leaks.

1. 1. Mark the belt running direction for reinstallation.
2. Loosen the tensioner pulley bolt, and then remove the timing belt.

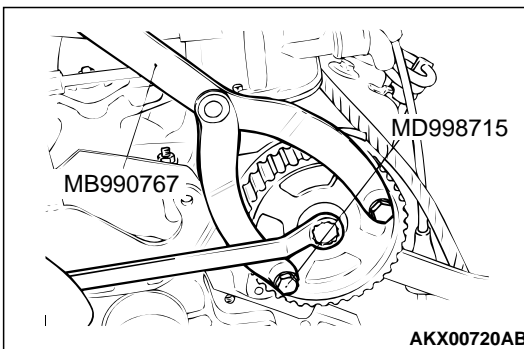
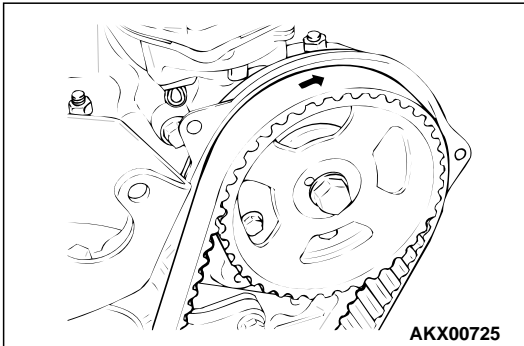

<> CAMSHAFT SPROCKET REMOVAL

1. While holding the camshaft sprocket with special tools MB990767 and MD998715, loosen the camshaft sprocket bolt.
2. Remove the camshaft sprocket.

INSTALLATION SERVICE POINT

>>A<< CAMSHAFT SPROCKET INSTALLATION

1. Fit the camshaft sprocket to the front end of the camshaft.
2. While holding the camshaft sprocket with special tools MB990767 and MD998715, tighten the camshaft sprocket bolt.

Tightening torque: 88 N·m (65 ft·lb)

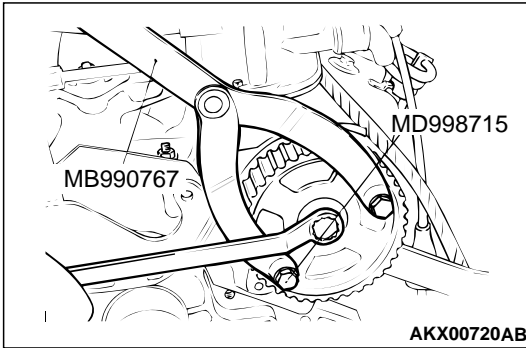

>>B<< AUTO-TENSIONER INSTALLATION

If the auto-tensioner rod is fully extended, reset it as follows:

1. Clamp the auto-tensioner in the vise with soft jaws.
2. Push in the rod little by little with the vise until the set hole A in the rod is aligned with the hole B in the cylinder.
3. Insert a wire [1.4 mm (0.055 inch) in diameter] into the set holes. This auto-tensioner setting wire will be used during timing belt alignment.
4. Unclamp the auto-tensioner from the vise.

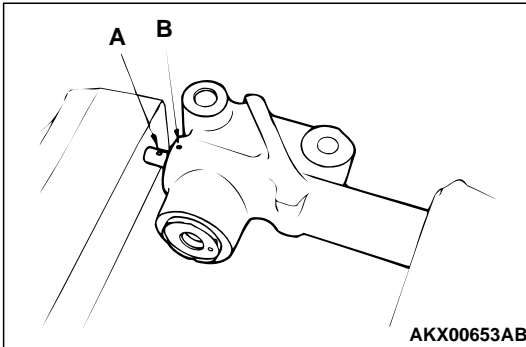

>>C<< TIMING BELT INSTALLATION

⚠ CAUTION

Do not turn the camshaft when the piston in No.1 cylinder is at the top dead center on the compression stroke. Doing so can cause the lifted valve to hit against the piston, resulting in damaging parts.

1. Install special tool MD998769 and the crankshaft pulley washer, and then tighten the crankshaft bolt.
2. Align the timing mark on the crankshaft sprocket with the timing mark on the oil pump case, and then rotate the sprocket three teeth counterclockwise.
3. Align the timing mark on the left bank camshaft sprocket with the timing mark on the rocker cover.
4. Align the timing mark on the right bank camshaft sprocket with the timing mark on the rocker cover.

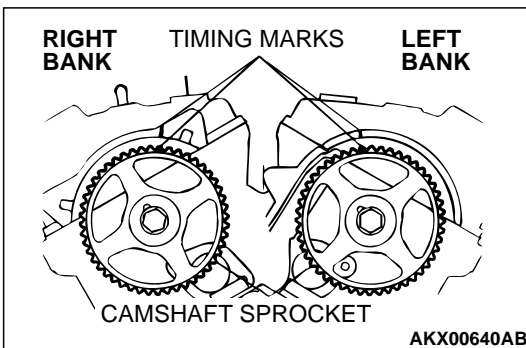
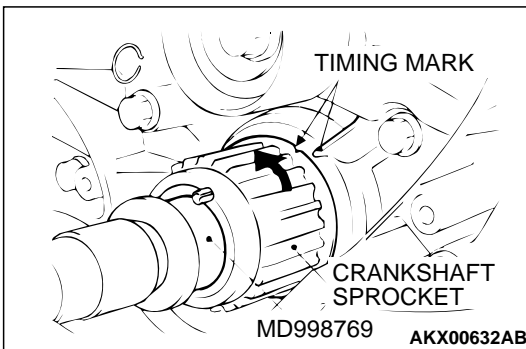

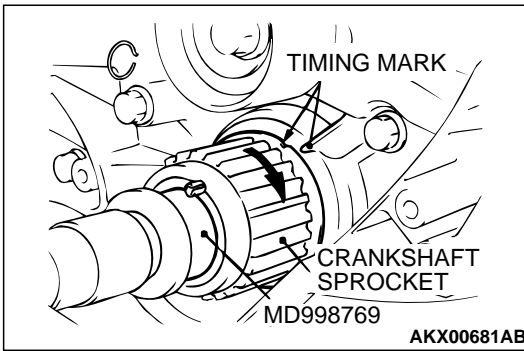

5. Align the timing mark on the crankshaft sprocket with the timing mark on the oil pump case.
6. Install the timing belt on each sprocket and pulley in the following sequence. Do not leave the belt slack between each sprocket and pulley.
 - (1) Crankshaft sprocket
 - (2) Idler pulley
 - (3) Left bank camshaft sprocket
 - (4) Water pump pulley
 - (5) Right bank camshaft sprocket
 - (6) Tensioner pulley
7. Install special tool MD998767 to the tensioner pulley. While pushing the pulley lightly against the belt using the special tool, tighten the flange bolt.

Tightening torque: 48 N·m (35 ft·lb)

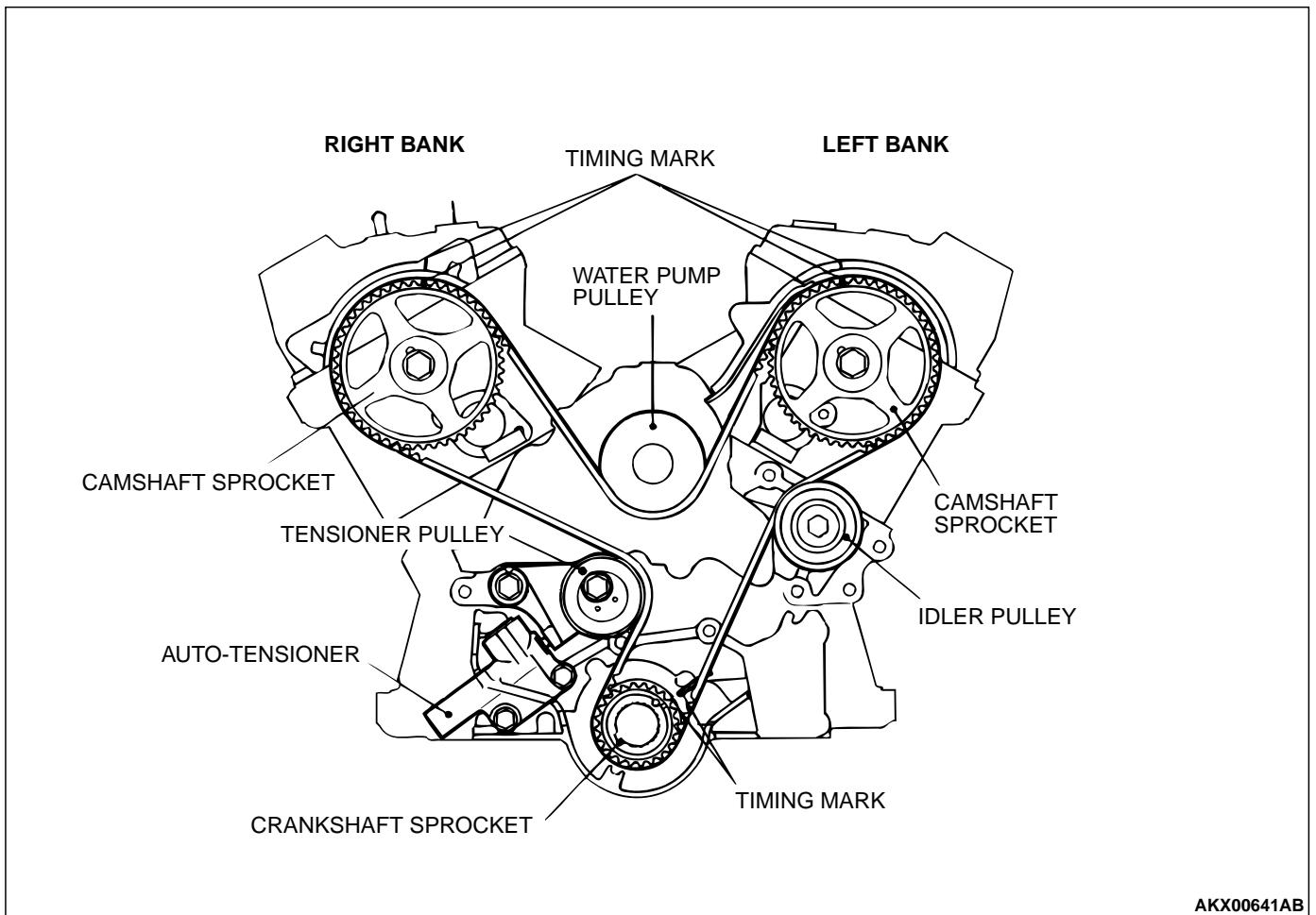
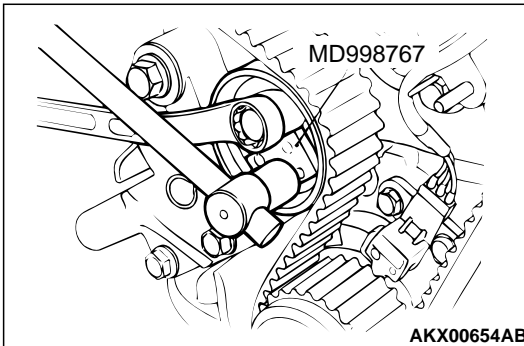

8. Check to see that the timing marks of all the sprockets are in a alignment.

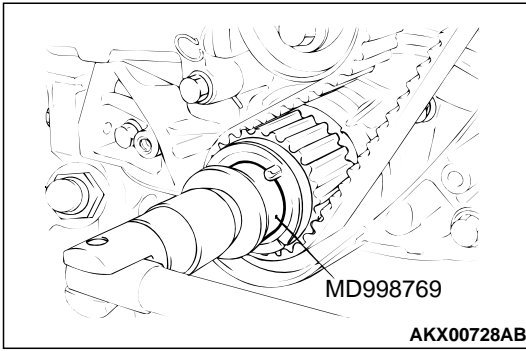

9. Rotate the crankshaft a quarter turn counterclockwise. Then rotate it back clockwise to verify that all the timing marks are aligned.

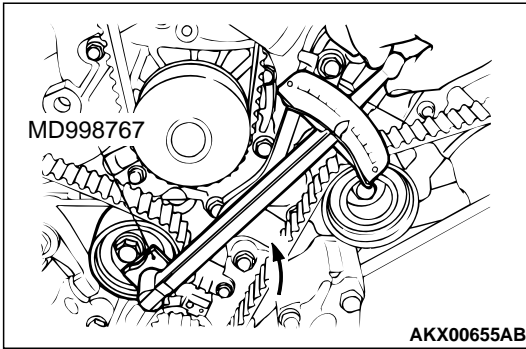

10. Loosen the flange bolt securing the tensioner pulley, and then mount special tool MD998767 and a torque wrench on the tensioner pulley.
11. Torque it to 4.4 N·m (39 in-lb) with the torque wrench.
12. While holding the tensioner pulley in position, tighten the flange bolt to the specified torque.

Tightening torque: 48 N·m (35 ft-lb)

13. Rotate the crankshaft two turns clockwise and leave it alone for approximately five minutes.

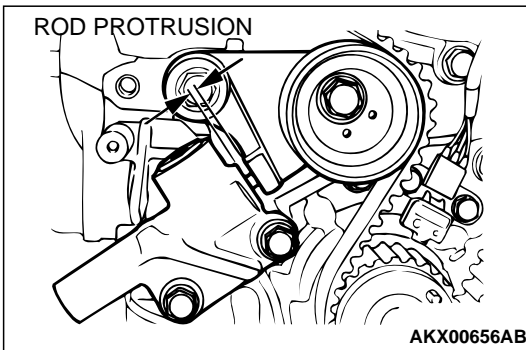

14. Check to see whether the metal wire inserted when the auto-tensioner was installed can be removed without any resistance. If the metal wire can be removed without any resistance, it means that the belt has a proper tension. Therefore, remove the metal wire. In this condition, check that the rod protrusion of the auto-tensioner is within the standard value.

Standard value: 3.8 – 5.0 mm (0.15 – 0.20 inch)

15. If the metal wire offers resistance when removed, repeat the previous steps (10) through (13) until proper belt tension is obtained.

>>D<< ENGINE SUPPORT BRACKET, RIGHT INSTALLATION

The mounting bolts of the right engine support bracket must be tightened in the order shown in the illustration.

Tightening torque: 44 N·m (33 ft-lb)

Bolt length

85 mm (3.35 inch) -- Bolt 3

95 mm (3.74 inch)-- Other bolts

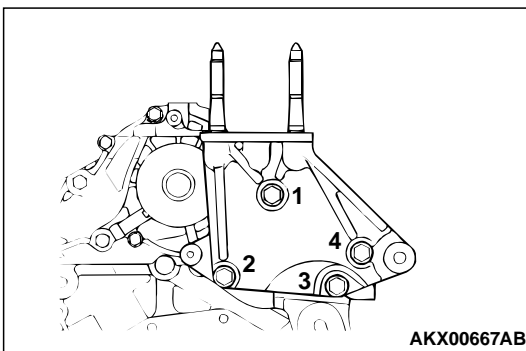

INSPECTION

TIMING BELT

Replace the belt if any of the following conditions exist.

1. Hardening of rubber backing.
Back side is glossy without resilience and leaves no indent when pressed with fingernail.

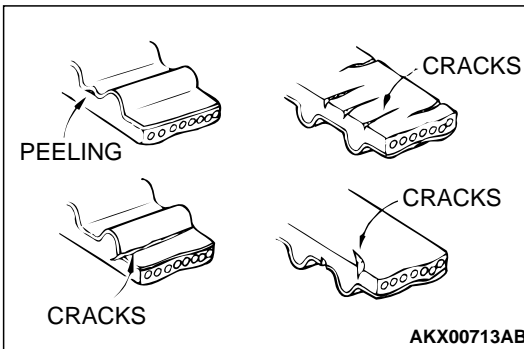
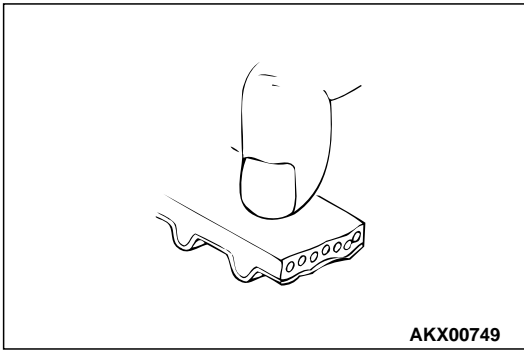

2. Cracks on rubber back
3. Cracks or peeling of canvas
4. Cracks on tooth bottom
5. Cracks on belt

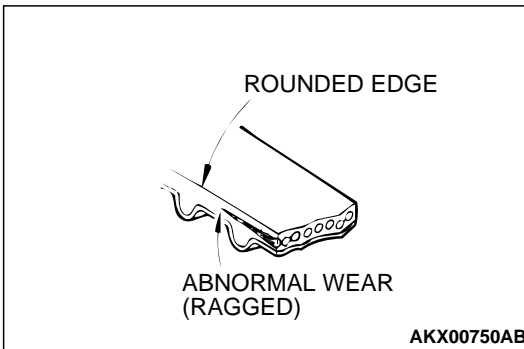

6. Abnormal wear of belt sides. Normal wear is indicated if the sides are sharp as if cut by a knife. Abnormal wear is indicated if the sides are ragged.

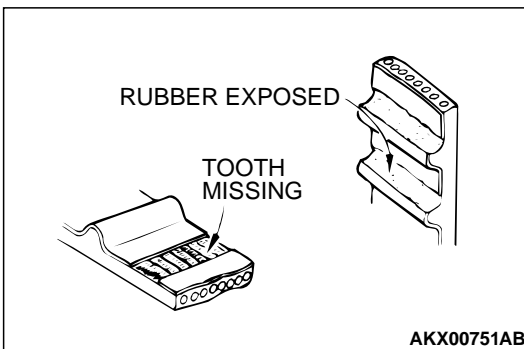

7. Abnormal wear on teeth.
8. Missing tooth.

TENSIONER PULLEY AND IDLER PULLEY

Turn the pulley. If it does not rotate smoothly, or develops noise or excessive play, replace the pulley.

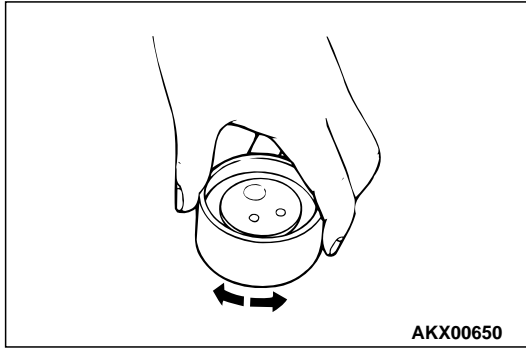
**AUTO-TENSIONER**

1. Check for oil leaks. If oil leaks are evident, replace the auto-tensioner.
2. Check the rod end for wear or damage and replace the auto-tensioner if necessary.
3. Measure the rod protrusion. If it is out of specification, replace the auto-tensioner.

Standard value: 12 mm (0.5 inch)

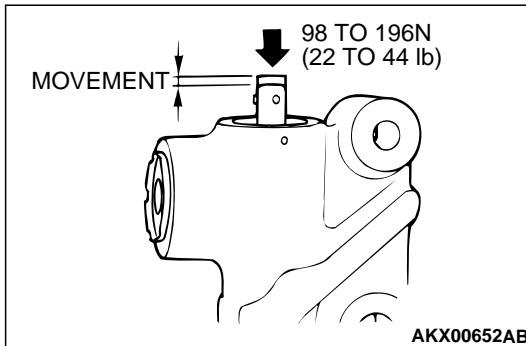
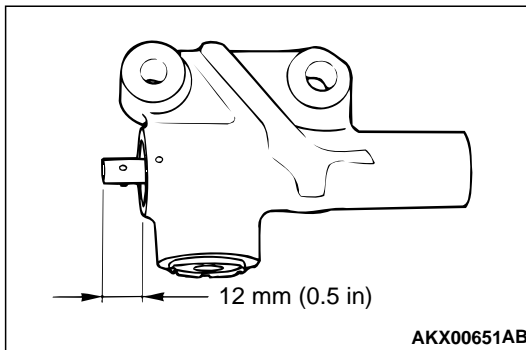

4. Press the rod with a force of 98 to 196 N (22 to 44 pounds) and measure the movement of the rod.

If the measured value is out of the standard value, replace the auto-tensioner.

Standard value: 1.0 mm (0.03 inch) or less

INTAKE MANIFOLD AND FUEL PARTS

REMOVAL AND INSTALLATION

M1113004300080

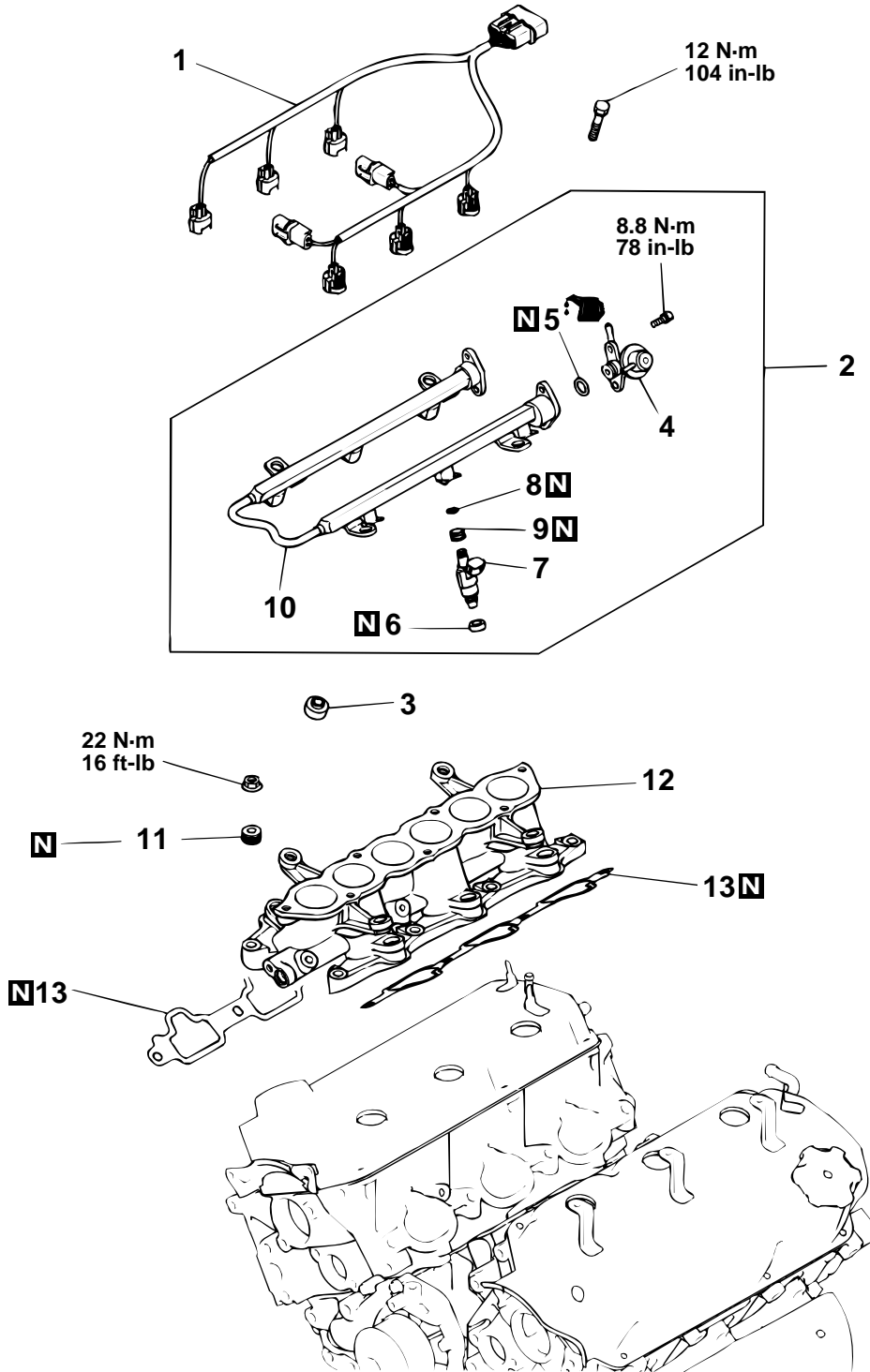

AKX00668AC

REMOVAL STEPS

- >>C<<
1. INJECTOR HARNESS
 2. INJECTOR AND FUEL RAIL
 3. INSULATOR
 4. FUEL PRESSURE REGULATOR
 5. O-RING

REMOVAL STEPS (Continued)

- >>B<<
6. INSULATOR
 7. INJECTOR
 8. O-RING
 9. GROMMET
 10. FUEL RAIL

TSB Revision

REMOVAL STEPS (Continued)

- >>A<<
 11. CONED DISC SPRING
 12. INTAKE MANIFOLD
 13. INTAKE MANIFOLD GASKET

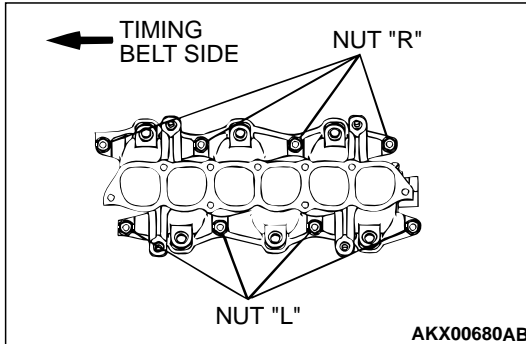
**INSTALLATION SERVICE POINTS****>>A<< INTAKE MANIFOLD INSTALLATION**

1. Tighten the nuts "R" to 6.4 N·m (57 in-lb).
2. Tighten the nuts "L" to the specified torque.

Tightening torque: 22 N·m (16 ft-lb)

3. Tighten the nuts "R" to the specified torque.

Tightening torque: 22 N·m (16 ft-lb)

4. Tighten the nuts "L" to the specified torque.

Tightening torque: 22 N·m (16 ft-lb)

5. Tighten the nuts "R" to the specified torque.

Tightening torque: 22 N·m (16 ft-lb)

>>B<< INJECTOR INSTALLATION**⚠ CAUTION**

Use care not to let engine oil enter the fuel rail.

1. Apply clean engine oil to the O-ring.
2. Insert the injector into the fuel rail.
3. Make sure the injector rotates smoothly. If not, remove the injector to check the O-ring for damage, and replace the O-ring if necessary. Then reinsert the injector and check that it rotates smoothly.

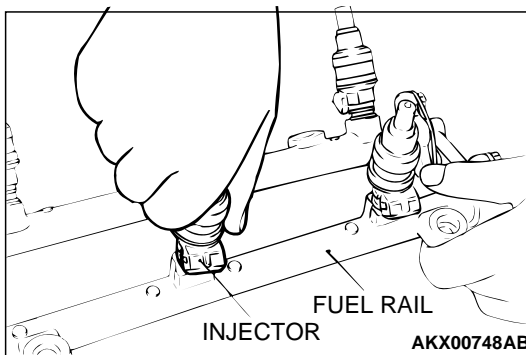

4. Align the projection on the injector connector with the mating mark on the fuel rail.

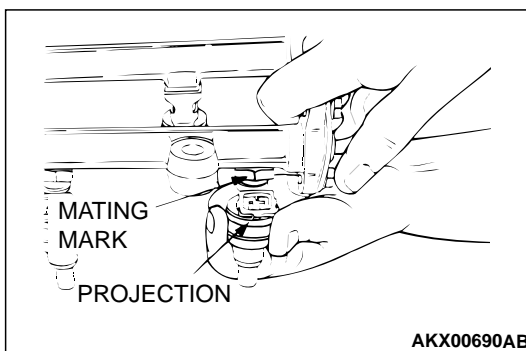
**>>C<< FUEL PRESSURE REGULATOR INSTALLATION****⚠ CAUTION**

Do not let engine oil enter the fuel rail.

1. Apply clean engine oil to the O-ring.
2. Insert the fuel pressure regulator into the fuel rail.
3. Make sure the regulator rotates smoothly. If not, remove the fuel pressure regulator to check the O-ring for damage, and replace the O-ring if necessary. Then reinsert the fuel pressure regulator and check that it rotates smoothly.
4. Tighten the two bolts to the specified torque.

REMOVAL STEPS (Continued)

- 10. GASKET
- 11. WATER INLET FITTING
- >>B<< 12. THERMOSTAT
- 13. THERMOSTAT HOUSING
- 14. GASKET
- >>A<< 15. O-RING
- >>A<< 16. WATER INLET PIPE
- >>A<< 17. O-RING
- 18. WATER PUMP
- 19. WATER PUMP GASKET

INSTALLATION SERVICE POINTS

>>A<< O-RING AND WATER INLET PIPE INSTALLATION

⚠ CAUTION

Keep the O-ring free of oil or grease.

1. Attach a new O-ring to each end of the water inlet pipe.
2. Wet the O-ring with water.
3. Insert the front end of the pipe into the water pump.

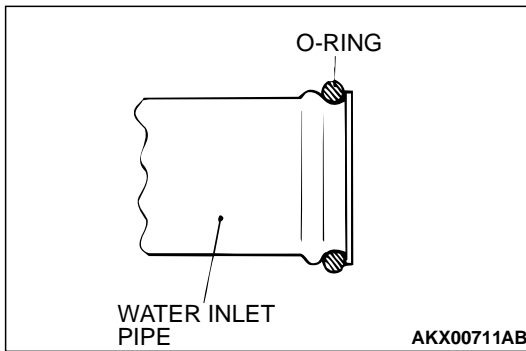

>>B<< THERMOSTAT INSTALLATION

1. Check that the rubber ring is free from damage and seated correctly in the thermostat flange.
2. Install the thermostat as shown in the illustration. The jiggle valve must be at the uppermost position.

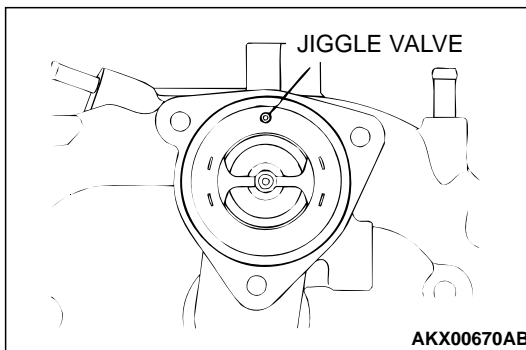

>>C<< SEALANT APPLICATION TO ENGINE COOLANT TEMPERATURE SENSOR

Apply 3M™ AAD Part number 8731 or equivalent to the engine coolant temperature sensor.

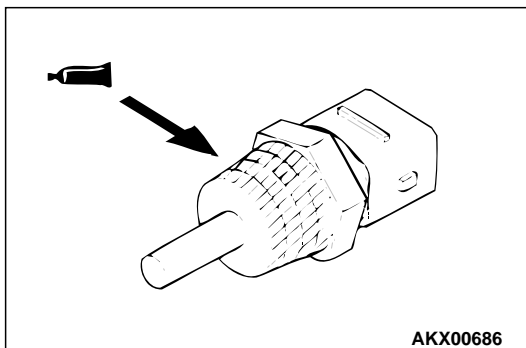

REMOVAL STEPS

1. HEAT PROTECTOR, UPPER RIGHT
2. HEAT PROTECTOR, FRONT RIGHT
3. HEAT PROTECTOR, RIGHT
4. HEAT PROTECTOR, LOWER RIGHT
5. EXHAUST MANIFOLD, RIGHT
6. EXHAUST MANIFOLD GASKET
7. HEAT PROTECTOR, UPPER LEFT

REMOVAL STEPS (Continued)

8. HEAT PROTECTOR, LEFT
9. HEAT PROTECTOR, LOWER LEFT
10. OXYGEN SENSOR
11. EXHAUST MANIFOLD, LEFT
12. EXHAUST MANIFOLD GASKET
13. ENGINE HANGER

ROCKER ARMS AND CAMSHAFT

REMOVAL AND INSTALLATION

M1113005400110

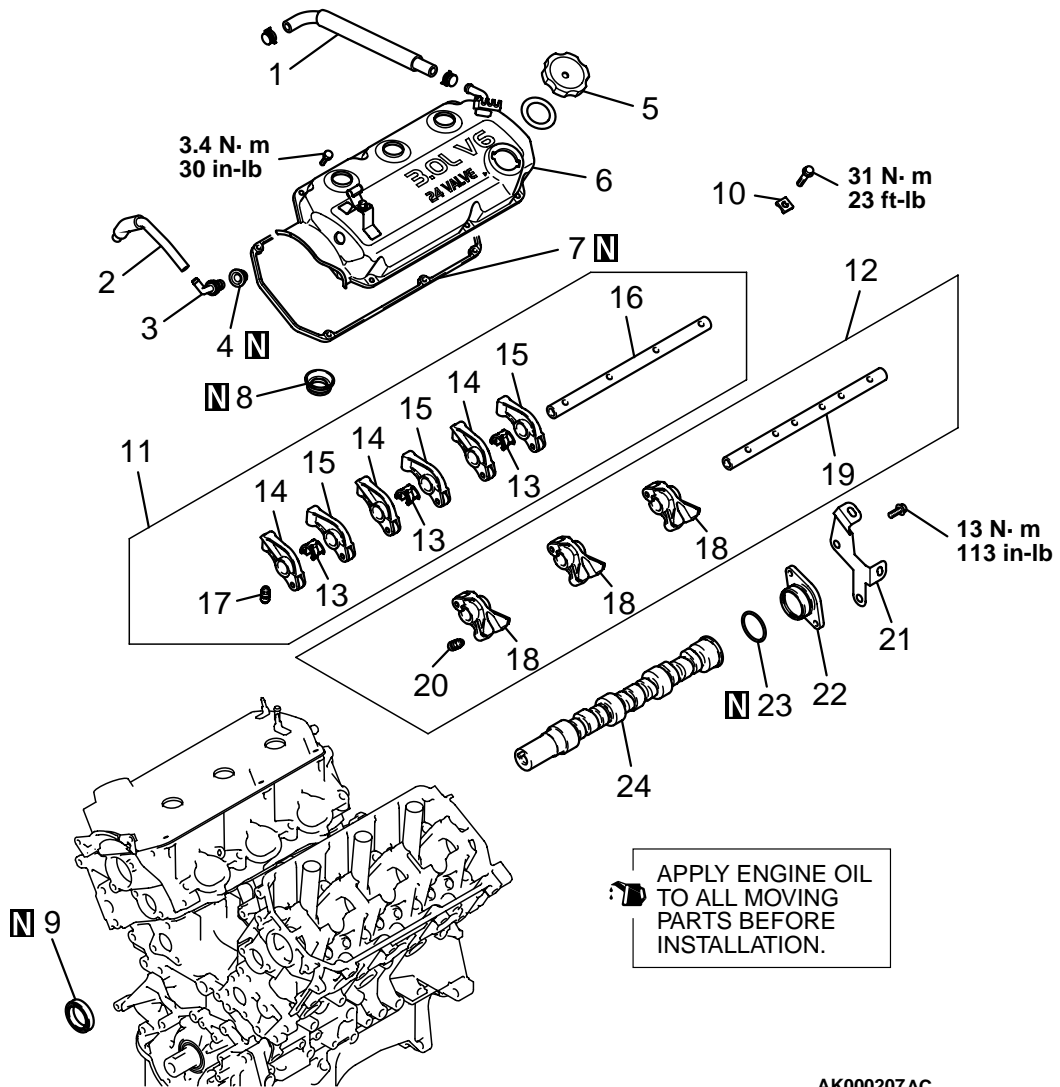

APPLY ENGINE OIL TO ALL MOVING PARTS BEFORE INSTALLATION.

AK000207 AC

REMOVAL STEPS

1. BREATHER HOSE
2. PCV HOSE
3. PCV VALVE
4. PCV VALVE GASKET
5. OIL FILLER CAP
6. ROCKER COVER

REMOVAL STEPS (Continued)

7. ROCKER COVER GASKET
8. OIL SEAL
- >>D<< 9. CAMSHAFT OIL SEAL
- <<A>> >>C<< 10.ROCKER SHAFT CAP
- <<A>> >>C<< 11.ROCKER ARMS AND SHAFT
- <<A>> >>C<< 12.ROCKER ARMS AND SHAFT

TSB Revision

REMOVAL STEPS (Continued)

- >>C<< 13.ROCKER SHAFT SPRING
- 14.ROCKER ARM A
- 15.ROCKER ARM B
- 16.ROCKER ARM SHAFT
- >>B<< 17.LASH ADJUSTER
- 18.ROCKER ARM C
- 19.ROCKER ARM SHAFT
- >>B<< 20.LASH ADJUSTER
- 21.HARNES BRACKET
- 22.THRUST CASE <LEFT BANK ONLY>
- 23.O-RING <LEFT BANK ONLY>
- >>A<< 24.CAMSHAFT

Required Special Tools:

MB991559: Camshaft Oil Seal Installer Adaptor
MD998442: Air Bleed Wire

MD998443: Lash Adjuster Holder

MD998713: Camshaft Oil Seal Installer

REMOVAL SERVICE POINT

<<A>> ROCKER ARMS AND SHAFT REMOVAL

⚠ CAUTION

If the lash adjuster is re-used, clean the lash adjuster.
(Refer to P.11D-25.)

Set special tool MD998443 to prevent the lash adjuster coming free and falling to the floor.

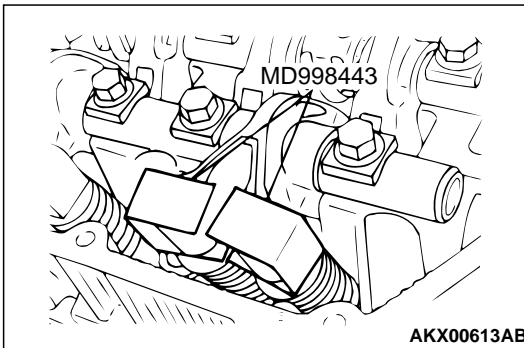

INSTALLATION SERVICE POINTS

>>A<< CAMSHAFT INSTALLATION

1. Apply engine oil to the camshaft journals and cams.
2. The camshaft for the right bank has a slit for driving the distributor at the rear end. The camshaft for the left bank has no slit. Be careful to install the correct camshaft in the correct position.

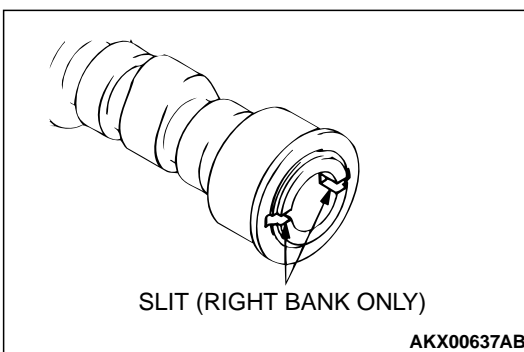

>>B<< LASH ADJUSTER INSTALLATION

⚠ CAUTION

If the lash adjuster is re-used, clean the lash adjuster. (Refer to P.11D-25.)

1. Fit the lash adjuster onto the rocker arm without allowing diesel fuel to spill out. Fit special tool MD998443 to prevent the lash adjuster coming free and falling to the floor.

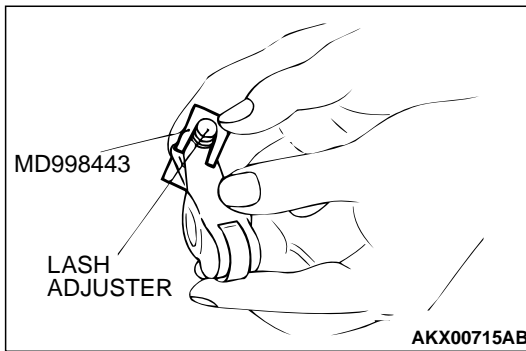

>>C<< ROCKER ARM, ROCKER ARM SHAFT AND ROCKER SHAFT SPRING INSTALLATION

1. Rotate the camshaft until the dowel pin on its front end is located as shown in the illustration.

NOTE: Placing the camshaft in the illustrated position minimizes the amount of cam lift, making it easier to install the rocker arm and shaft assemblies.

2. Install the exhaust side rocker arm "C" and shaft assembly to the cylinder head.
3. Install the inlet side rocker arms "A" and "B" and shaft assembly to the cylinder head.
4. Insert the rocker shaft spring to the intake side rocker arm shaft as illustrated.

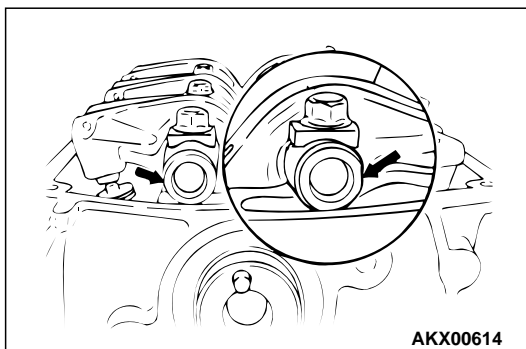
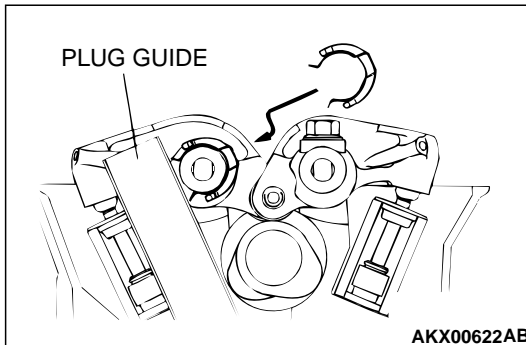
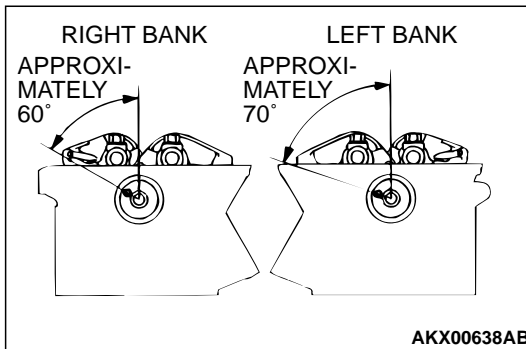

5. Make sure that the notch in the end of the rocker arm shaft is facing the direction as shown.

>>D<< CAMSHAFT OIL SEAL INSTALLATION

1. Apply engine oil to the lip area of the oil seal and the front end outside diameter of the camshaft.
2. Using special tools MD998713 and MB991559 (for the left bank only), install the camshaft oil seals.

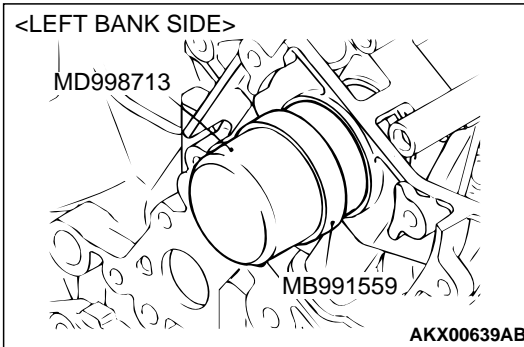
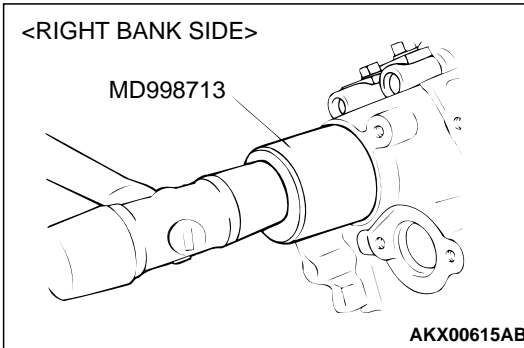

INSPECTION

M1113005500043

CAMSHAFT

Measure the cam height. If it is below the limit, replace the camshaft.

Standard value:

Intake 37.58 mm (1.480 inches)

Exhaust 36.95 mm (1.455 inches)

Minimum limit:

Intake 37.08 mm (1.460 inches)

Exhaust 36.45 mm (1.435 inches)

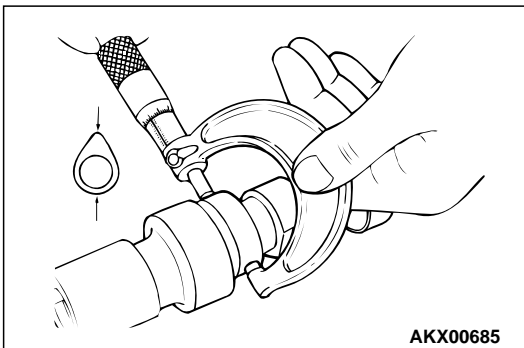

ROCKER ARM

1. Check the roller surface. If any dents, damage or seizure is evident, replace the rocker arm.
2. Check rotation of the roller. If it does not rotate smoothly or if looseness is evident, replace the rocker arm.
3. Check the inside diameter. If damage or seizure is evident, replace the rocker arm.

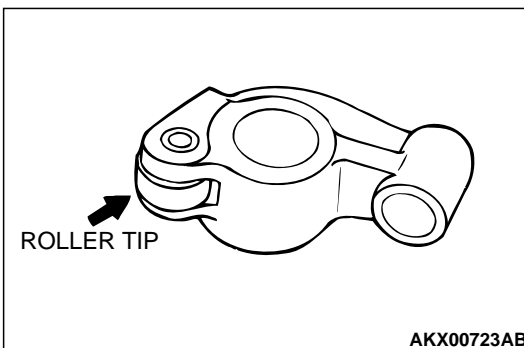

LASH ADJUSTERS

⚠ CAUTION

- The lash adjusters are precision-engineered mechanisms. Do not allow them to become contaminated by dirt or other foreign substances.
- Do not attempt to disassemble the lash adjusters.
- Use only fresh diesel fuel to clean the lash adjusters.

1. Prepare three containers and approximately 5 dm³ (30.5 quart) of diesel fuel. Into each container, pour enough diesel fuel to completely cover a lash adjuster when it is standing upright. Then, perform the following steps with each lash adjuster.

2. Place the lash adjuster in container A and clean its outside surface.

NOTE: Use a nylon brush if deposits are hard to remove.

⚠ CAUTION

The steel ball spring is extremely weak, so the lash adjuster's functionality may be lost if the air bleed wire is pushed in hard.

3. While gently pushing down the internal steel ball using wire [0.5 mm (0.020 inch) indiameter] or special tool MD998442, move the plunger through five to ten strokes until it slides smoothly. In addition to eliminating stiffness in the plunger, this operation will remove dirty oil.

NOTE: If the plunger remains stiff or the mechanism appears otherwise abnormal, replace the lash adjuster.

4. Remove the lash adjuster from the container. Then, push down the steel ball gently and push the plunger to eliminate diesel fuel from the pressure chamber.

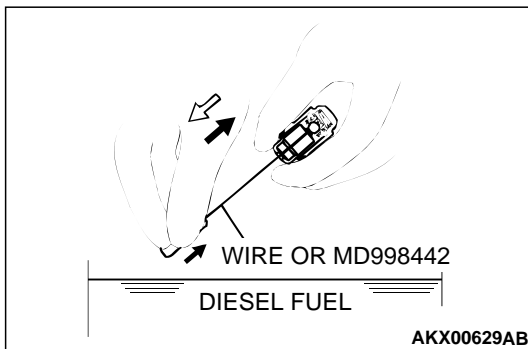
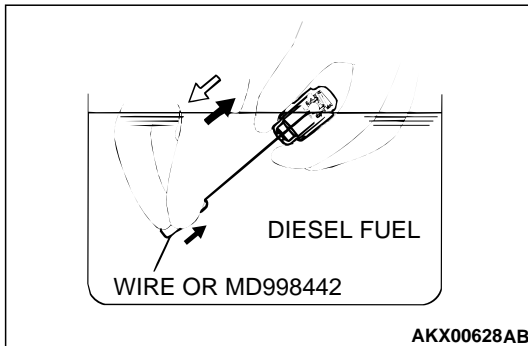
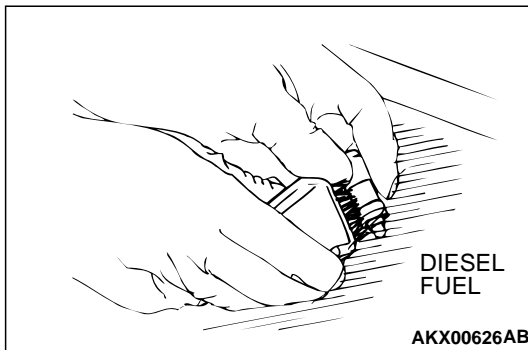
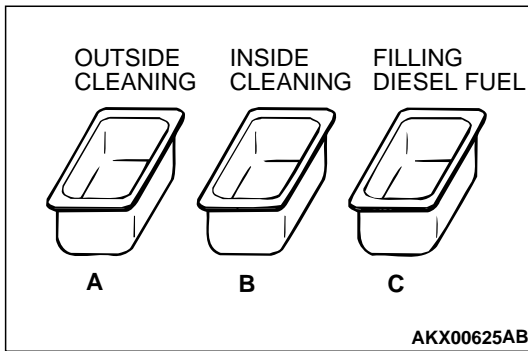

⚠ CAUTION

The steel ball spring is extremely weak, so the lash adjuster's functionality may be lost if the air bleed wire is pushed in hard.

- Place the lash adjuster in container B. Then, gently push down the internal steel ball using wire [0.5 mm (0.020 inch) indiameter] or special tool MD998442 and move the plunger through five to ten strokes until it slides smoothly. This operation will clean the lash adjuster's pressure chamber.

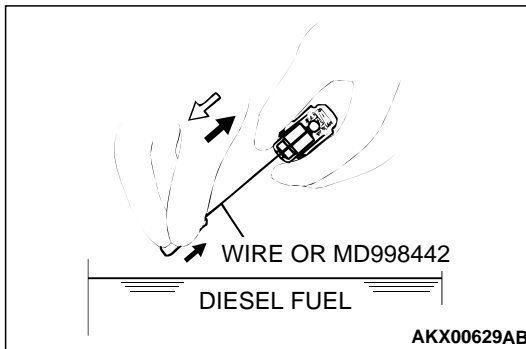
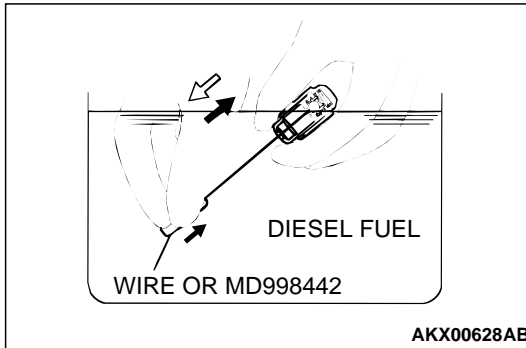

- Remove the lash adjuster from the container. Then, push down the steel ball gently and push the plunger to eliminate diesel fuel from the pressure chamber.

⚠ CAUTION

Do not use container C for cleaning. If cleaning is performed in container C, foreign matter could enter the pressure chamber when the chamber is filled with diesel fuel.

- Place the lash adjuster in container C. Then, gently push down the internal steel ball using wire [0.5 mm (0.020 inch) indiameter] or special tool MD998442.

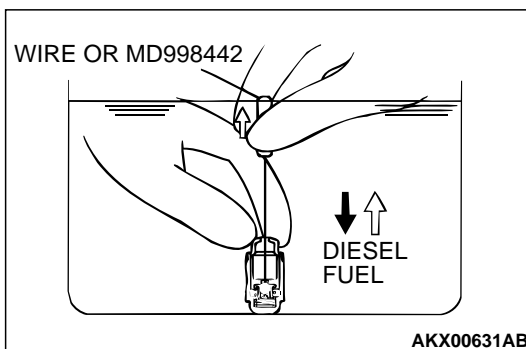
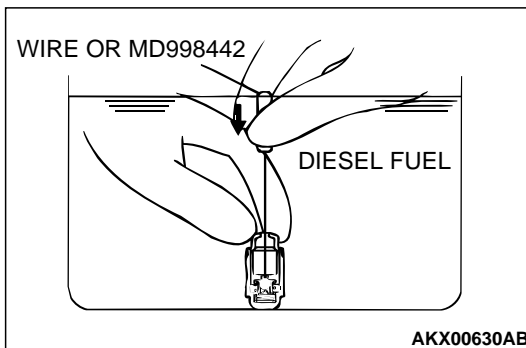

- Stand the lash adjuster with its plunger at the top, then push the plunger downward firmly until it moves through its greatest possible stroke. Return the plunger slowly, then release the steel ball and allow the pressure chamber to fill with diesel fuel.

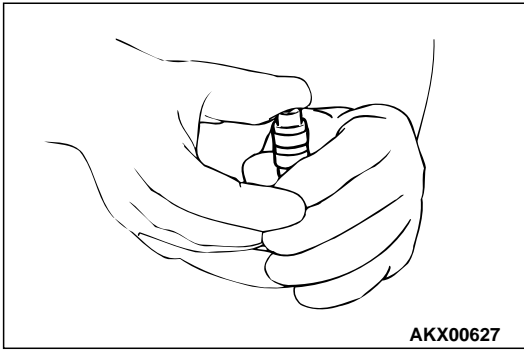

AKX00627

- Remove the lash adjuster from the container, then stand the lash adjuster with its plunger at the top. Push the plunger firmly and check that it does not move. Also, check that the lash adjuster's height matches that of a new lash adjuster.

NOTE: . If the lash adjuster contracts or moves, perform the operations (7) through (9) again to fill it with diesel fuel completely. Replace the lash adjuster if it still contracts or moves after performing these steps.

- Stand the lash adjuster upright to prevent diesel fuel from spilling out. Do not allow the lash adjuster to become contaminated by dirt or other foreign matter. Fit the lash adjuster onto the engine as soon as possible.

CYLINDER HEAD AND VALVES

REMOVAL AND INSTALLATION

M1113006900099

 APPLY ENGINE OIL TO ALL MOVING PARTS BEFORE INSTALLTION.

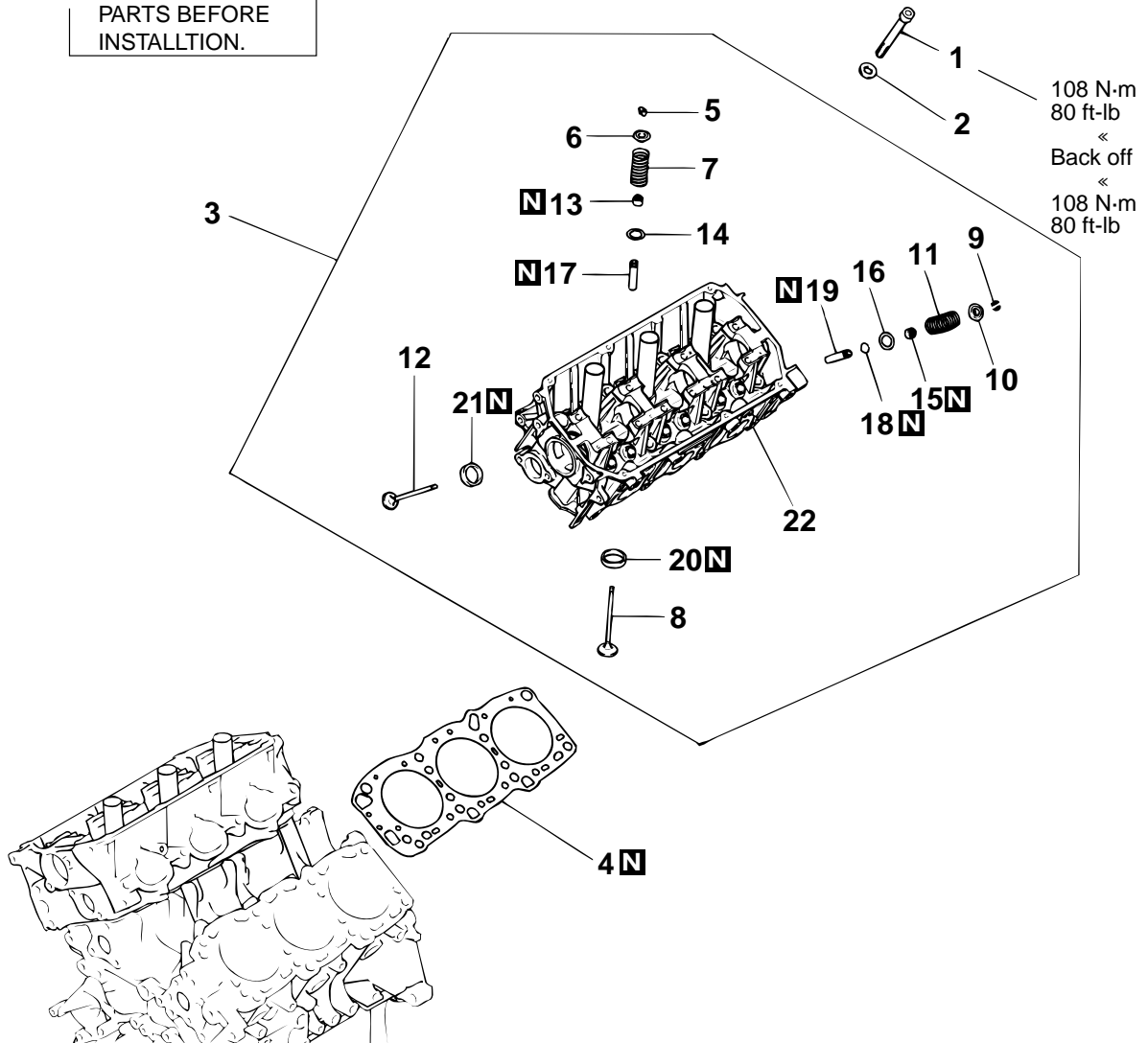

AKX00644AC

TSB Revision

- REMOVAL STEPS**
- <<A>> >>D<<
>>D<<
1. CYLINDER HEAD BOLT
 2. WASHER
 3. CYLINDER HEAD ASSEMBLY
 4. CYLINDER HEAD GASKET
- <> >>C<<
>>B<<
5. RETAINER LOCK
 6. VALVE SPRING RETAINER
 7. VALVE SPRING
 8. INLET VALVE
- <> >>C<<
>>B<<
9. RETAINER LOCK
 10. VALVE SPRING RETAINER
 11. VALVE SPRING

- REMOVAL STEPS (Continued)**
- >>A<<
>>A<<
12. EXHAUST VALVE
 13. VALVE STEM SEAL
 14. VALVE SPRING SEAT
 15. VALVE STEM SEAL
 16. VALVE SPRING SEAT
 17. INLET VALVE GUIDE
 18. SNAP RING
 19. EXHAUST VALVE GUIDE
 20. INLET VALVE SEAT
 21. EXHAUST VALVE SEAT
 22. CYLINDER HEAD

Required Special Tools:
MD998051: Cylinder Head Bolt Wrench

MD998772: Valve Spring Compressor
MD998774: Valve Stem Seal Installer

REMOVAL SERVICE POINTS

<<A>> CYLINDER HEAD BOLT REMOVAL

Using special tool MD998051, loosen the cylinder head bolts. Loosen each bolt evenly, little by little, by two or three steps.

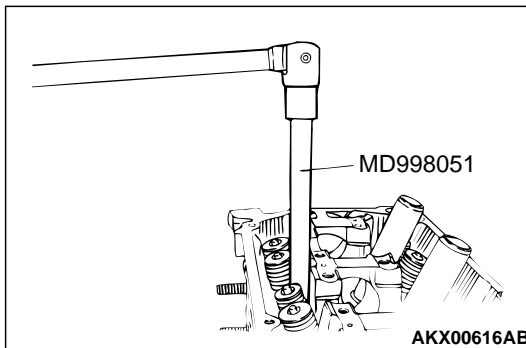

<> RETAINER LOCK REMOVAL

1. Set special tool MD998772 as illustrated to compress the valve spring. Remove the retainer locks.
 2. Relieve the spring tension and remove the valve, retainer, spring, etc.
- Store removed valves, springs and other parts, tagged to indicate their cylinder number and location for assembly.

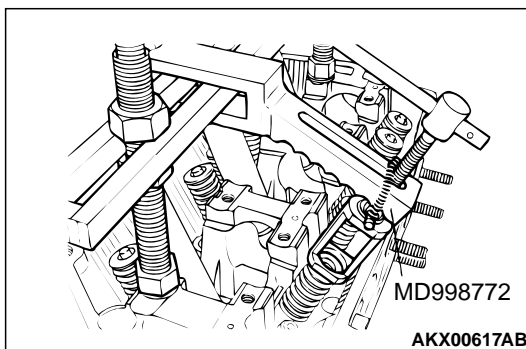

INSTALLATION SERVICE POINTS

>>A<< VALVE STEM SEAL INSTALLATION

1. Install the valve spring seat.

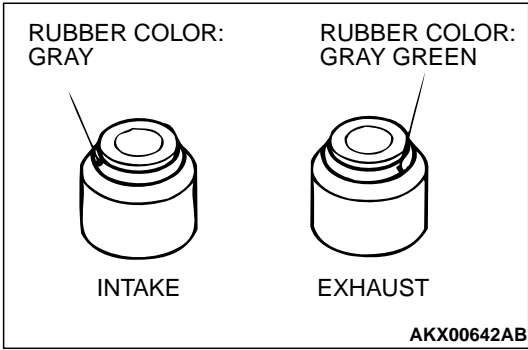

⚠ CAUTION

The valve stem seal for the exhaust side is different than the intake side. They are identified by their respective rubber colors. When installing, do not confuse them.

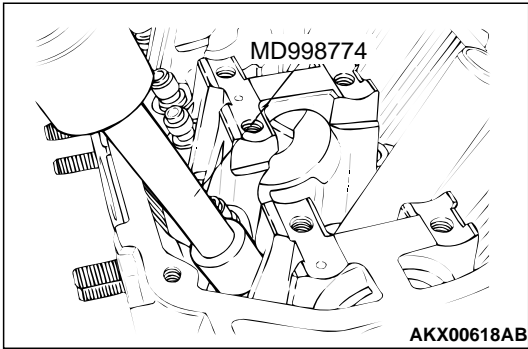

⚠ CAUTION

The special tool must be used to install the valve stem seal. Improper installation could result in oil leaking past the valve guide.

2. Using special tool MD998774, install a new stem seal to the valve guide.

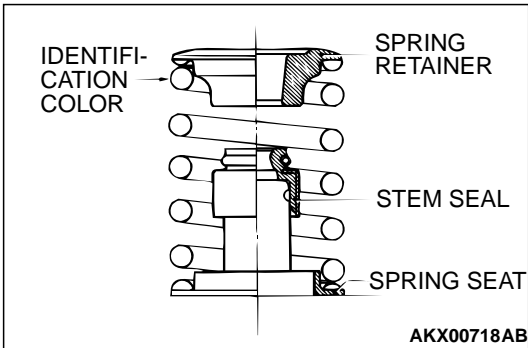

>>B<< VALVE SPRING INSTALLATION

Install the valve spring with its ID color painted end (larger pitch side) upward (toward the valve spring retainer).

>>C<< RETAINER LOCK INSTALLATION

⚠ CAUTION

Do not compress the valve spring excessively. It can damage the stem seal.

1. Set special tool MD998772 as illustrated to compress the valve spring. Install the retainer locks.
2. Relieve the spring tension and check that the retainer locks are seated correctly.

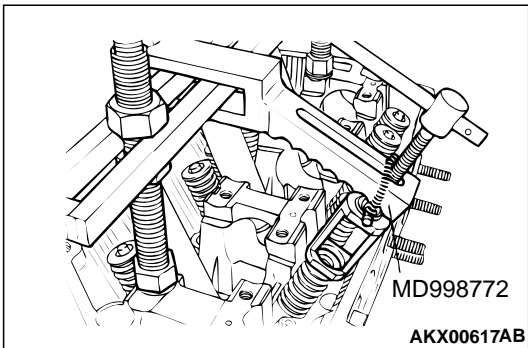

>>D<< CYLINDER HEAD BOLT INSTALLATION

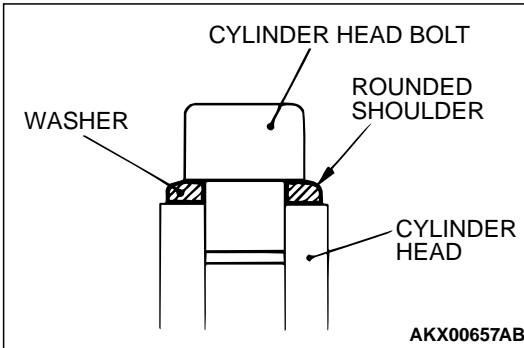

1. Insert the cylinder head bolt with a washer attached into the bolt hole in the cylinder head. The washer must be set with the "rounded shoulder" side upward.

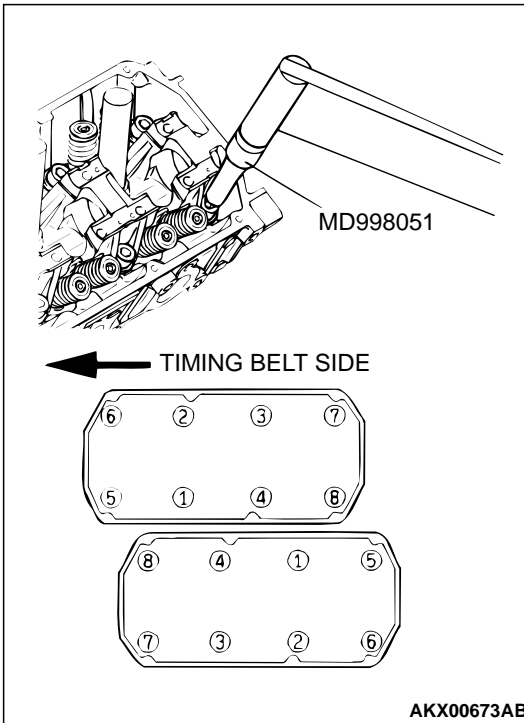

2. Tighten the cylinder head bolts to the specified torque in the sequence shown.

Tightening torque: 108 N·m (80 ft-lb)

3. Loosen all bolts fully.
4. Retighten the cylinder head bolts to the specified torque in the sequence shown.

Tightening torque: 108 N·m (80 ft-lb)

INSPECTION

M1113007000044

CYLINDER HEAD

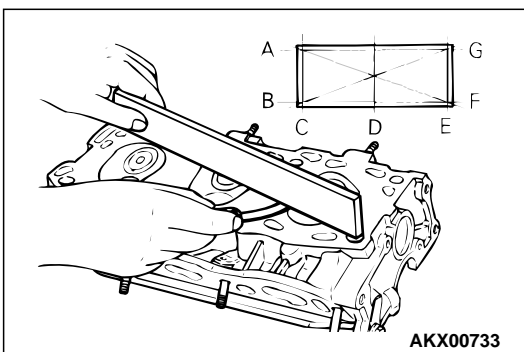

1. Check the cylinder head gasket surface for flatness by using a straightedge and feeler gauge in the directions of A through G shown in the illustration.

Standard value: 0.03 mm (0.0012 inch)

Limit: 0.2 mm (0.007 inch)

2. If it exceeds the limit, correct to meet the specification.

Grinding limit: *0.2 mm (0.007 inch)

***Includes combined with cylinder block grinding.**

**Cylinder head height (specification when new):
120 mm (4.7 inches)**

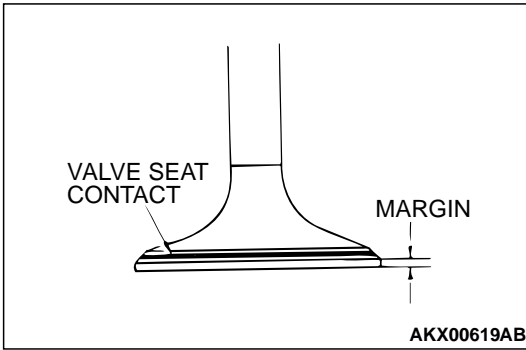

VALVE

1. Check the valve seat contact. The valve seat contact should be uniform at the center of the valve face. If incorrect, reface using a valve refacer.
2. If the margin is below the limit, replace the valve.

Standard value:

- <Intake> 1.0 mm (0.04 inch)
- <Exhaust> 1.2 mm (0.05 inch)

Minimum limit:

- <Intake> 0.5 mm (0.02 inch)
- <Exhaust> 0.7 mm (0.03 inch)

3. Measure the valve's total length. If the measurement is less than the limit, replace the valve.

Standard value:

- <Intake> 112.30 mm (4.421 inches)
- <Exhaust> 114.11 mm (4.493 inches)

Minimum limit:

- <Intake> 111.80 mm (4.402 inches)
- <Exhaust> 113.61 mm (4.473 inches)

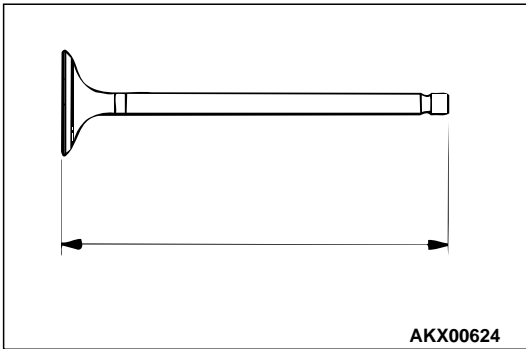

VALVE SPRINGS

1. Measure the free height of the springs. If it is less than the limit, replace.

Standard value: 51.0 mm (2.01 inches)

Minimum limit: 50.0 mm (1.97 inches)

2. Measure the squareness of the springs. If it exceeds the limit, replace.

Standard value: 2 degree angle

Limit: 4 degree angle

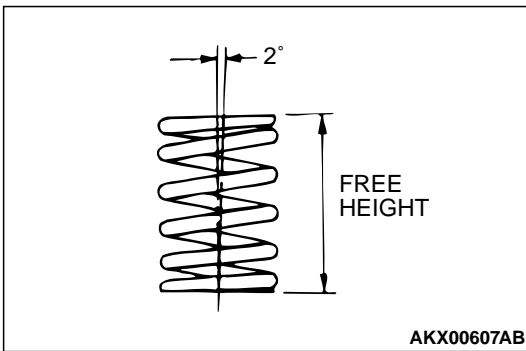

VALVE GUIDES

Measure the clearance between the valve guide and valve stem. If it exceeds the limit, replace the valve guide or valve, or both.

Standard value:

- Intake 0.02 – 0.05 mm (0.0008 – 0.0019 inch)
- Exhaust 0.04 – 0.07 mm (0.0016 – 0.0027 inch)

Limit:

- Intake 0.10 mm (0.003 inch)
- Exhaust 0.15 mm (0.005 inch)

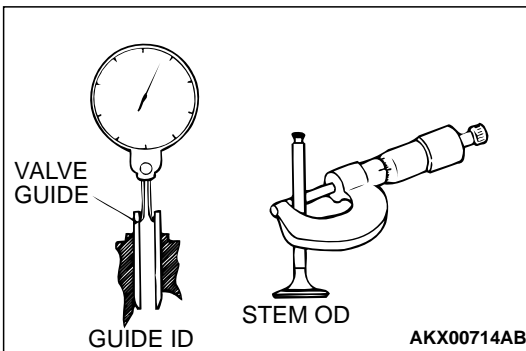

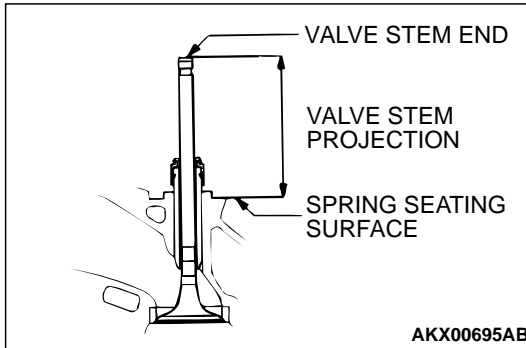

VALVE SEAT

Assemble the valve, then measure the valve stem projection between the end of the valve stem and the spring seating surface. If the measurement exceeds the specified limit, replace the valve seat.

Standard value: 49.30 mm (1.941 inches)
Limit: 49.80 mm (1.960 inches)

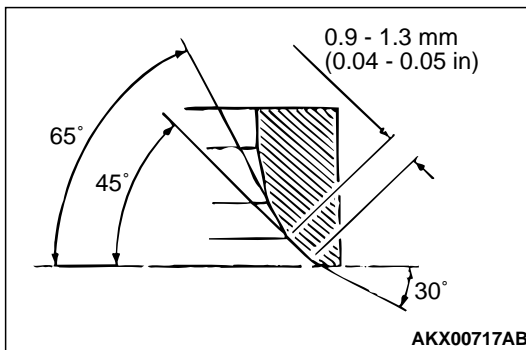

VALVE SEAT RECONDITIONING PROCEDURE

1. Before correcting the valve seat, check for the clearance between the valve guide and valve and, if necessary, replace the valve guide.
2. Using the special tool or a seat grinder, correct to obtain the specified seat width and angle.
3. After correcting the valve seat, lap the valve and valve seat using lapping compound. Then, check the valve stem projection.

VALVE SEAT REPLACEMENT PROCEDURE

1. Cut the valve seat from the inside to thin the wall thickness. Then, remove the valve seat.

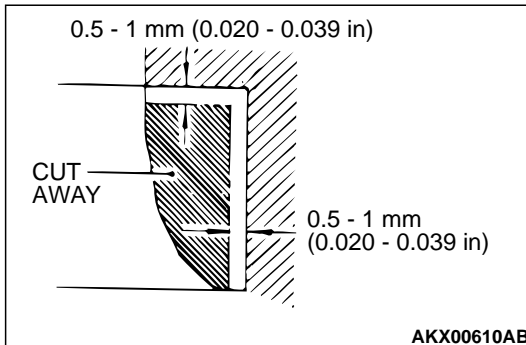

2. Rebore the valve seat hole in the cylinder head to a selected oversize valve seat diameter.

Seat ring hole diameter:

Intake valve

0.3 OS 34.30 – 34.33 mm (1.3504 – 1.3516 inches)

0.6 OS 34.60 – 34.63 mm (1.3622 – 1.3634 inches)

Exhaust valve

0.3 OS 31.80 – 31.83 mm (1.2520 – 1.2531 inches)

0.6 OS 32.10 – 32.13 mm (1.2638 – 1.2650 inches)

3. Before fitting the valve seat, either heat the cylinder head up to approximately 250°C (482°F) or cool the valve seat in liquid nitrogen, to prevent the cylinder head bore from galling.
4. Using a valve seat cutter, correct the valve seat to the specified width and angle.

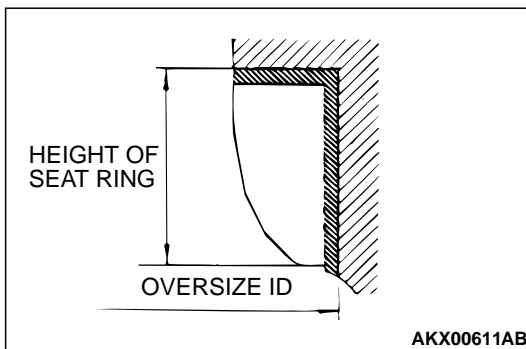

See "VALVE SEAT RECONDITIONING PROCEDURE" on the previous page.

VALVE GUIDE REPLACEMENT PROCEDURE

1. Remove the snap ring from the exhaust valve guide.
2. Using a press, remove the valve guide toward the cylinder block.

CAUTION

Do not install a valve guide of the same size again.

3. Rebore the valve guide hole of the cylinder head so that it fits the press-fitted oversize valve guide.

Valve guide hole diameter:

0.05 OS 11.05 – 11.07 mm (0.4350 – 0.4358 inch)

0.25 OS 11.25 – 11.27 mm (0.4429 – 0.4457 inch)

0.50 OS 11.50 – 11.52 mm (0.4528 – 0.4535 inch)

4. Install the new snap ring into groove of the exhaust valve guide.

NOTE: The inlet valve guide has no snap ring groove.

5. Press-fit the valve guide until it protrudes 14 mm (0.6 inch) from the cylinder head top surface as shown in the illustration.

NOTE: When press-fitting the valve guide, work from the cylinder head top surface.

NOTE: After installing the valve guides, insert new valves in them to check for smooth operation.

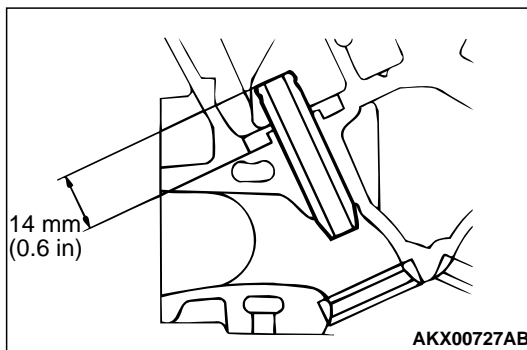
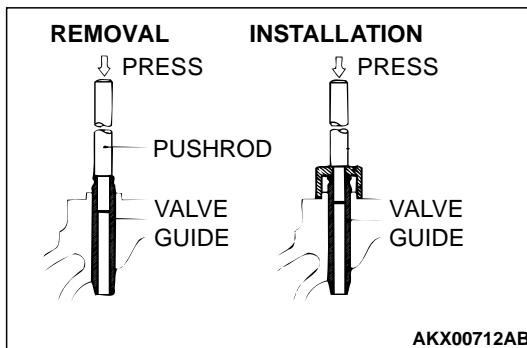

OIL PAN AND OIL PUMP

REMOVAL AND INSTALLATION

M1113008100099

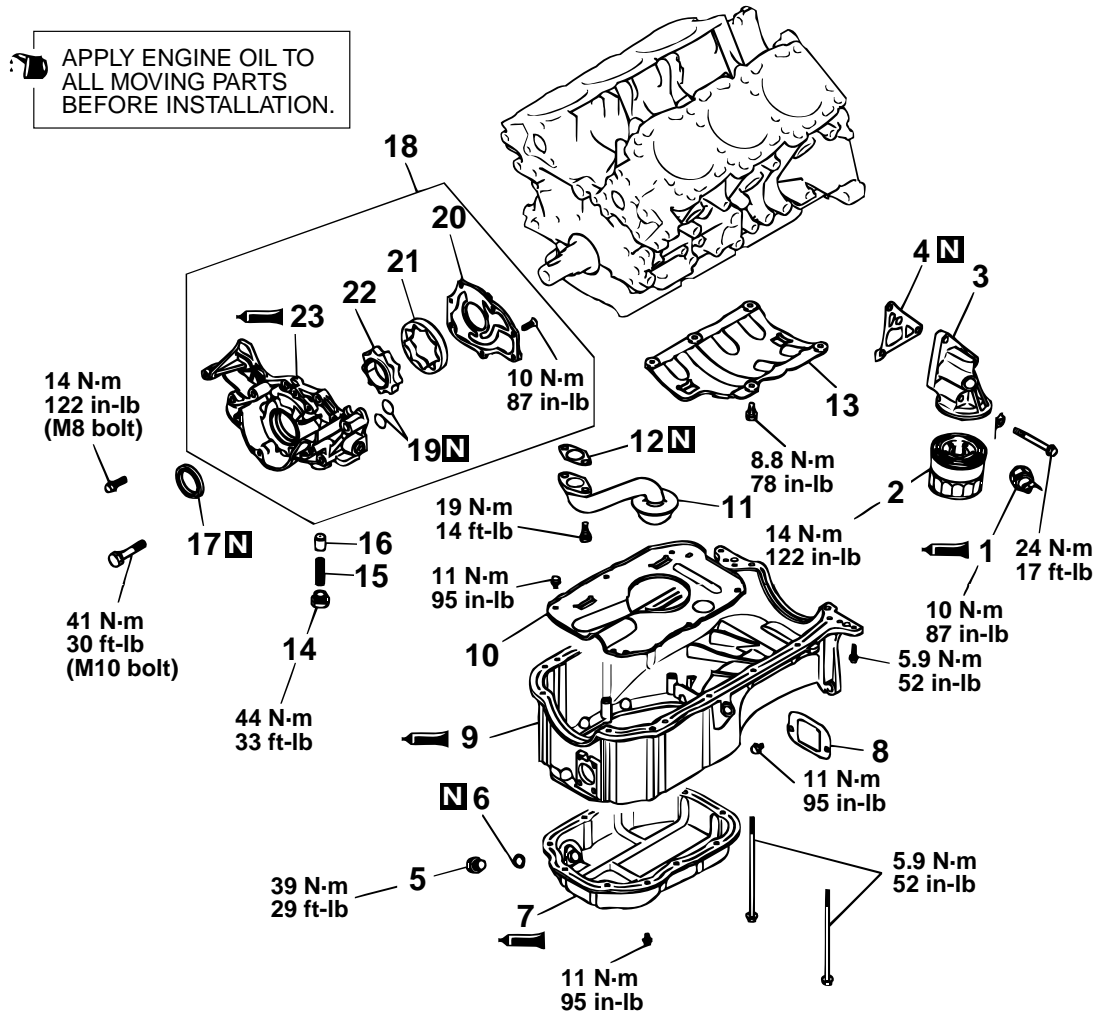

AKX00682AC

REMOVAL STEPS

- >>H<< 1. OIL PRESSURE SWITCH
- >>G<< 2. OIL FILTER
- 3. OIL FILTER BRACKET
- 4. OIL FILTER BRACKET GASKET
- 5. DRAIN PLUG
- >>F<< 6. DRAIN PLUG GASKET
- <<A>> >>E<< 7. OIL PAN, LOWER
- 8. COVER
- <> >>D<< 9. OIL PAN, UPPER
- 10. BAFFLE PLATE
- 11. OIL SCREEN
- 12. OIL SCREEN GASKET

REMOVAL STEPS (Continued)

- 13. BAFFLE PLATE
- 14. PLUG
- 15. RELIEF SPRING
- 16. RELIEF PLUNGER
- >>C<< 17. CRANKSHAFT FRONT OIL SEAL
- >>B<< 18. OIL PUMP CASE ASSEMBLY
- 19. O-RING
- 20. OIL PUMP COVER
- <<C>> >>A<< 21. OIL PUMP OUTER ROTOR
- <<C>> >>A<< 22. OIL PUMP INNER ROTOR
- 23. OIL PUMP CASE

Required Special Tool:

MD998717: Crankshaft Front Oil Seal Installer

TSB Revision

REMOVAL SERVICE POINT**<<A>>OIL PAN, LOWER REMOVAL**

1. Remove the lower oil pan mounting bolts.

⚠ CAUTION

Do not use a scraper or special tool to remove the oil pan.

2. Remove the lower oil pan by tapping on the side wall with a plastic hammer (mallet) through a wooden plank held against it.

<>OIL PAN, UPPER REMOVAL

1. Remove the long bolts "A" shown in the illustration first.
2. Remove all other bolts.

⚠ CAUTION

Do not use a scraper or special tool to remove the oil pan.

3. Screw M10 bolts into the two bolt holes in the oil pan to break the joint and remove the oil pan.

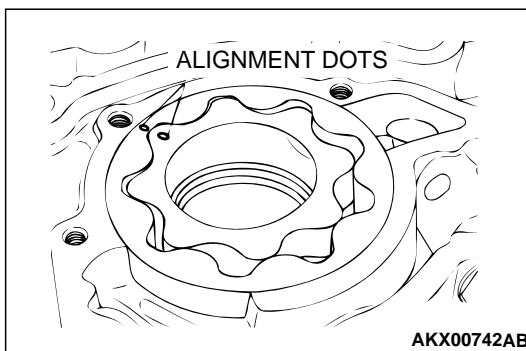
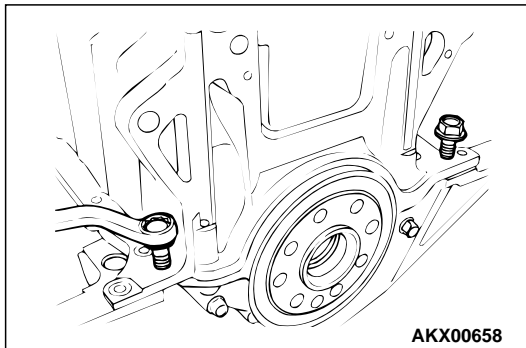
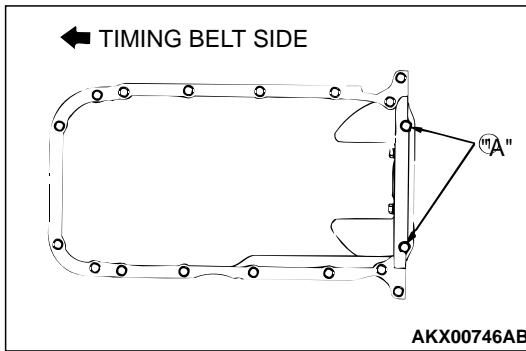
**<<C>>OUTER ROTOR/INNER ROTOR REMOVAL**

Make alignment dots on the outer and inner rotors for assembly.

INSTALLATION SERVICE POINTS

>>A<< INNER ROTOR/OUTER ROTOR INSTALLATION

Apply engine oil to the rotors. Then, install the rotors ensuring that the alignment dots made at disassembly are properly aligned.

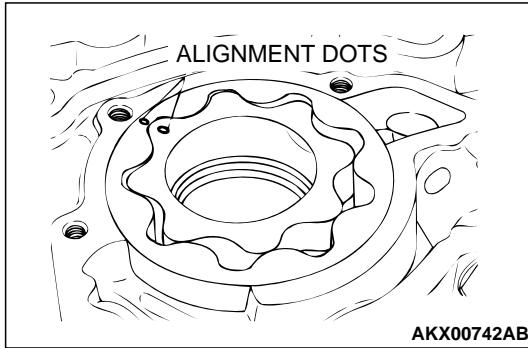

>>B<< OIL PUMP CASE ASSEMBLY INSTALLATION

1. Clean the gasket mating surfaces of oil pump case and cylinder block.
2. Apply a 3-mm (0.1-inch) diameter bead of sealant (Mitsubishi Genuine Parts number MD970389 or equivalent) to the oil pump case.

Apply sealant as indicated by the broken line in the illustration; the grooves must be traced and the bolt holes must be surrounded with a bead of sealant.

3. Install the oil pump case assembly to the front of the cylinder block.

NOTE: Be sure to install the oil pump case quickly while the sealant is wet (within 15 minutes).

4. Tighten the oil pump case mounting bolts to the specified torque.

Tightening torque:

14 N·m (122 in-lb) <M8 bolt>

41 N·m (30 ft-lb) <M10 bolt>

NOTE: After installation, keep the sealed area away from oil and coolant for approximately one hour.

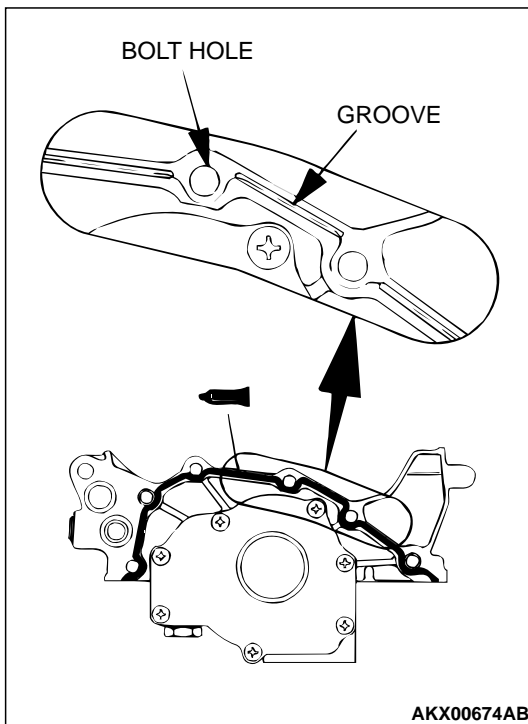

>>C<< CRANKSHAFT FRONT OIL SEAL INSTALLATION

1. Install the guide of special tool MD998717 to the front end of the crankshaft.
2. Apply engine oil to the lip area of a new oil seal and push it in until it contacts the oil pump case.

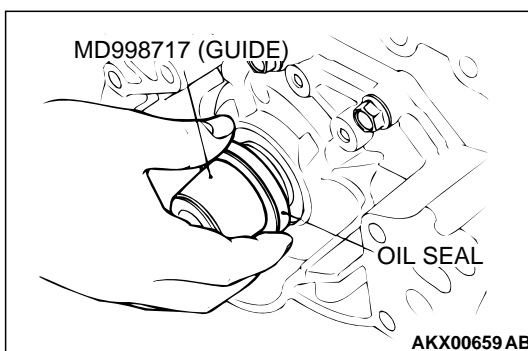

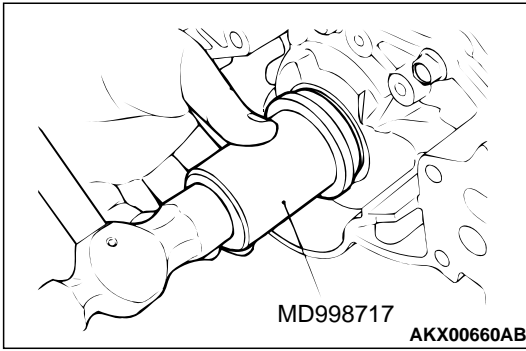

- Using special tool MD998717, press-fit the oil seal into the oil pump case.

>>D<< OIL PAN, UPPER INSTALLATION

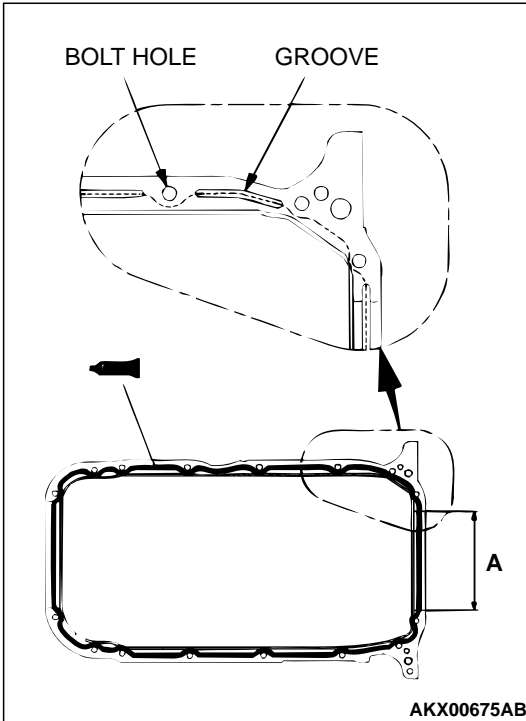

- Clean both gasket surfaces of the upper oil pan and cylinder block.
- Apply a 4 mm (0.2 inch) diameter bead of sealant (Mitsubishi Genuine Parts number MD970389 or equivalent) to the upper oil pan.
Apply sealant as indicated by the broken line in the illustration; the grooves must be traced and the bolt holes must be surrounded with a bead of sealant.

⚠ CAUTION

When installing the upper oil pan, be sure not to expel the sealant from the oil pan flange at portion A in the illustration.

- Install the oil pan to the bottom of the cylinder block.
NOTE: Be sure to install the oil pan quickly while the sealant is wet (within 15 minutes).

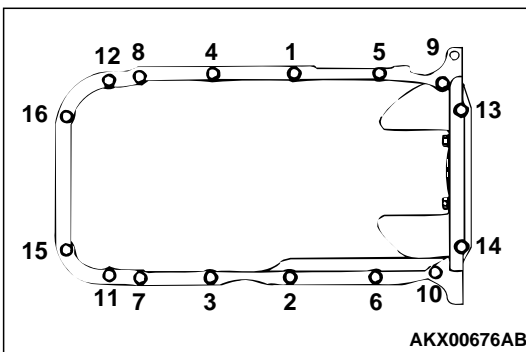

- Tighten the upper oil pan bolts in the sequence shown.
Tightening torque: 5.9 N·m (52 in-lb)
NOTE: After installation, keep the sealed area away from the oil and coolant for approximately one hour.

>>E<< OIL PAN, LOWER INSTALLATION

1. Clean both gasket surfaces of the upper and lower oil pans.
2. Apply a 4 mm (0.2 inch) diameter bead of sealant (Mitsubishi Genuine Parts number MD970389 or equivalent) to the lower oil pan.

Apply sealant as indicted by the broken line in the illustration; the grooves must be traced and the bolt holes must be surrounded with a bead of sealant.

3. Install the lower oil pan to the upper oil pan.

NOTE: Be sure to install the oil pan quickly while the sealant is wet (within 15 minutes).

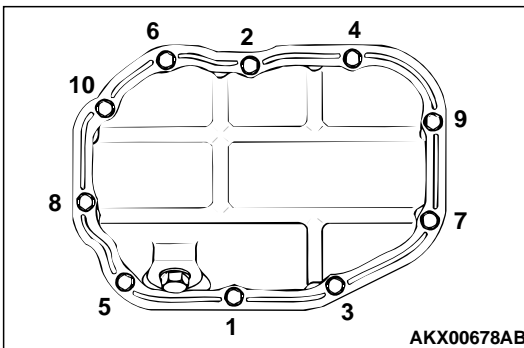
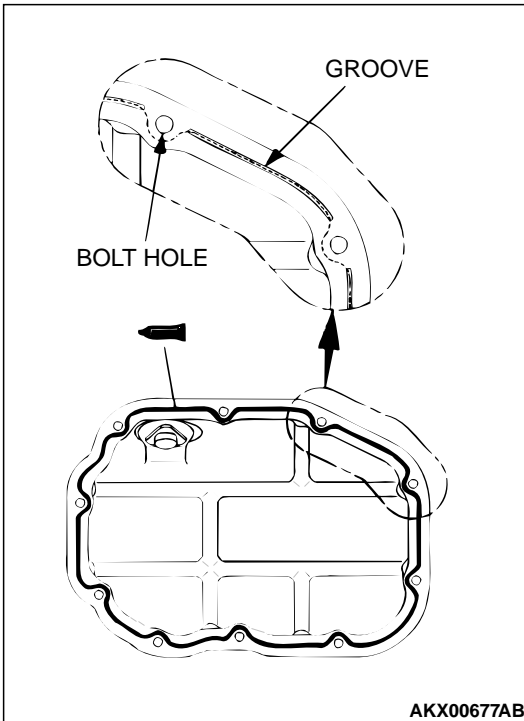

4. Tighten the lower oil pan bolts in the sequence shown.

Tightening torque: 11 N·m (95 in-lb)

NOTE: After installation, keep the sealed area away from oil for approximately one hour.

>>F<< DRAIN PLUG GASKET INSTALLATION

⚠ CAUTION

If the gasket is installed in the wrong direction, oil leaks will be occurred.

Install the drain plug gasket in the direction shown.

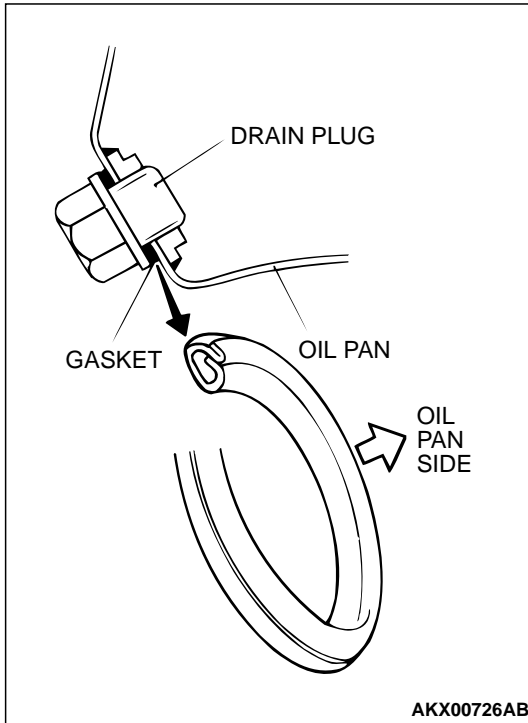

>>G<< OIL FILTER INSTALLATION

1. Clean the installation surface of the filter bracket.
2. Apply engine oil to the O-ring of the oil filter.
3. Install the oil filter to the bracket and tighten it to the specified torque.

Tightening torque: 14 N·m (122 in-lb)

4. If no torque wrench can be used for tightening, follow the following procedure.
 - (1) Screw in the oil filter until its O-ring contacts the oil filter bracket.
 - (2) Tighten the oil filter 3/4 turn.

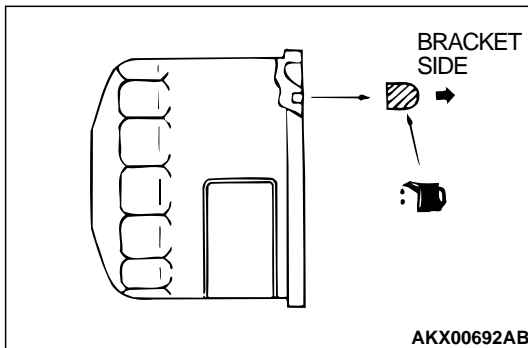

>>H<< OIL PRESSURE SWITCH INSTALLATION

⚠ CAUTION

Be careful not to block the oil passage with sealant.

1. Apply 3M™ AAD Part number 8672 or equivalent to the thread of oil pressure switch.
2. Tighten the switch to the specified torque.

Tightening torque: 10 N·m (87 in-lb)

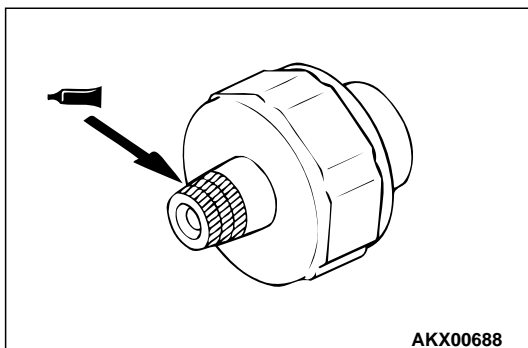

INSPECTION

OIL PUMP

1. Check the tip clearance.

Standard value: 0.06 – 0.18 mm (0.003 – 0.007 inch)

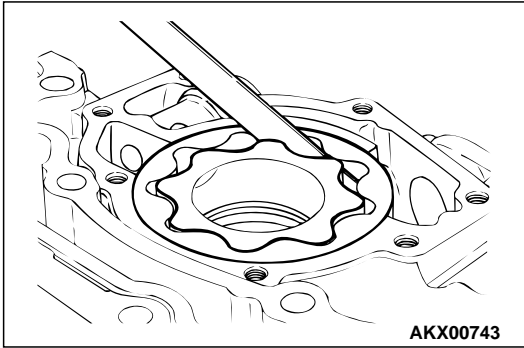

2. Check the side clearance.

Standard value: 0.04 – 0.10 mm (0.002 – 0.003 inch)

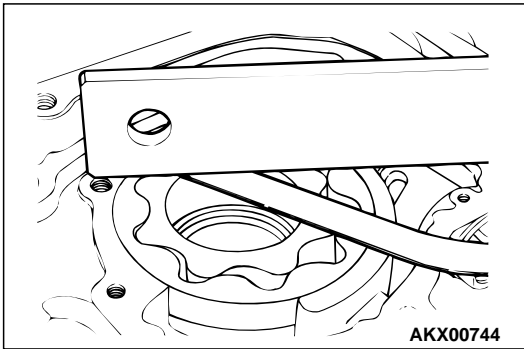

3. Check the body clearance.

Standard value: 0.10 – 0.18 mm (0.004 – 0.007 inch)
Limit: 0.35 mm (0.013 inch)

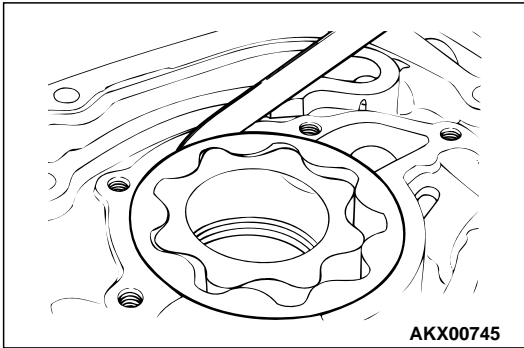

PISTON AND CONNECTING ROD

REMOVAL AND INSTALLATION

M1113008400108

 APPLY ENGINE OIL TO ALL MOVING PARTS BEFORE INSTALLATION.

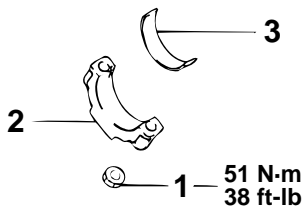
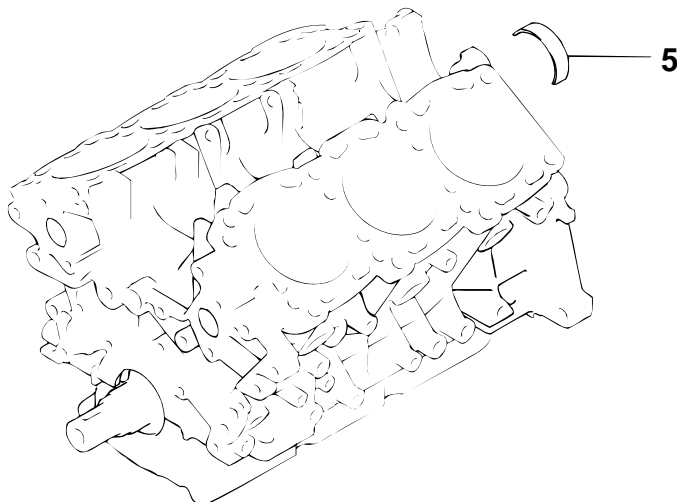
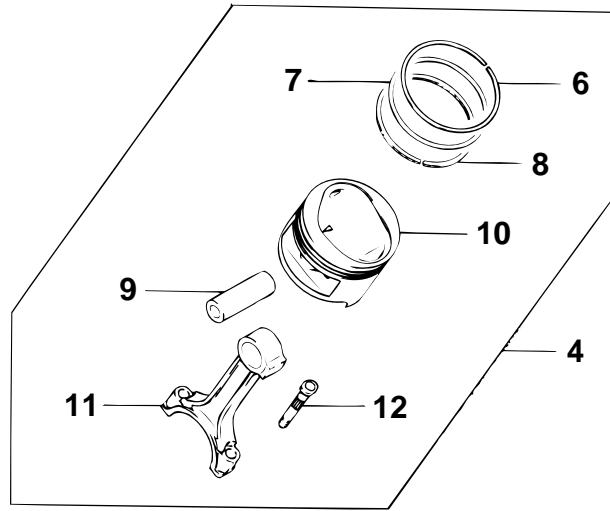

AKX00729AC

REMOVAL STEPS

- <<A>> >>E<< 1. NUT
- >>D<< 2. CONNECTING ROD CAP
- 3. CONNECTING ROD BEARING, LOWER
- >>D<< 4. PISTON AND CONNECTING ROD ASSEMBLY
- 5. CONNECTING ROD BEARING, UPPER

REMOVAL STEPS (Continued)

- >>C<< 6. PISTON RING NO.1
- >>C<< 7. PISTON RING NO.2
- >>B<< 8. OIL RING
- <> >>A<< 9. PISTON PIN
- 10. PISTON
- 11. CONNECTING ROD
- 12. BOLT

TSB Revision

Required Special Tool:

MIT216941: Piston Pin Setting Tool

REMOVAL SERVICE POINTS

<<A>>CONNECTING ROD CAP REMOVAL

1. Mark the cylinder number on the side of the connecting rod big end for correct reassembly.
2. Keep the removed connecting rods, caps, and bearings in order according to the cylinder number.

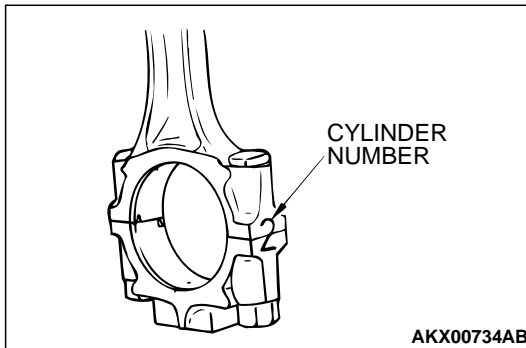

<> PISTON PIN REMOVAL

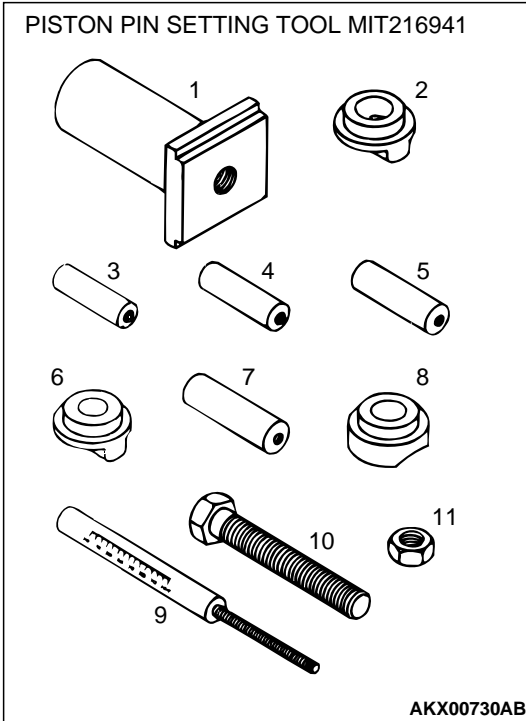

ITEM NO.	PART NO.	DESCRIPTION
1	MIT310134	Base
2	MIT310136	Piston support
3	MIT310137	Connecting rod guide pin
4	MIT310138	Connecting rod guide pin
5	MIT310139	Connecting rod guide pin
6	MIT310140	Piston support
7	MIT310141	Connecting rod guide pin
8	MIT310142	Piston support
9	MIT48143	Press pin
10	216943	Stop screw
11	10396	Nut

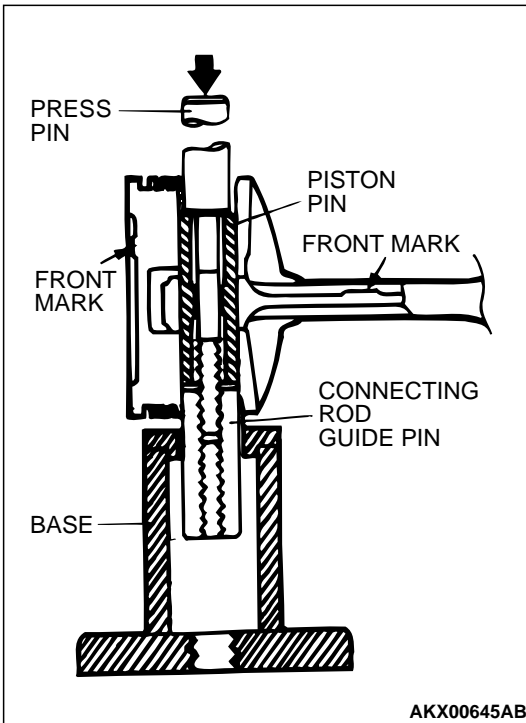

1. Remove the stop screw from the base.
2. Select the correct piston support for your application. (See above) Fit the piston support onto the base. Place the base on the press support blocks.
3. Insert the press pin through the piston pin hole. Select the correct connecting rod guide pin. (See above.) Thread the guide pin onto the threaded portion of the press pin.
4. Position the piston assembly on the piston support in the press. With the press pin up as shown, insert the guide pin through the hole in the piston and through the hole in the piston support.

⚠ CAUTION

To avoid piston damage, the piston support must seat squarely against the piston. Verify that the piston pin will slide through the hole in the piston support.

5. Press the piston pin out of the assembly.
6. Remove the piston pin from the piston pin.

INSTALLATION SERVICE POINTS

>>A<< PISTON PIN INSTALLATION

1. Thread the stop screw and jam nut assembly into the base. Fit the correct piston support on top of the base. Insert the press pin, threaded end up, into the hole in the piston support until the press pin touches the stop screw.
2. Using the graduations on the press pin, adjust the stop screw to the depth.

Depth: 60 mm (2.36 inches)

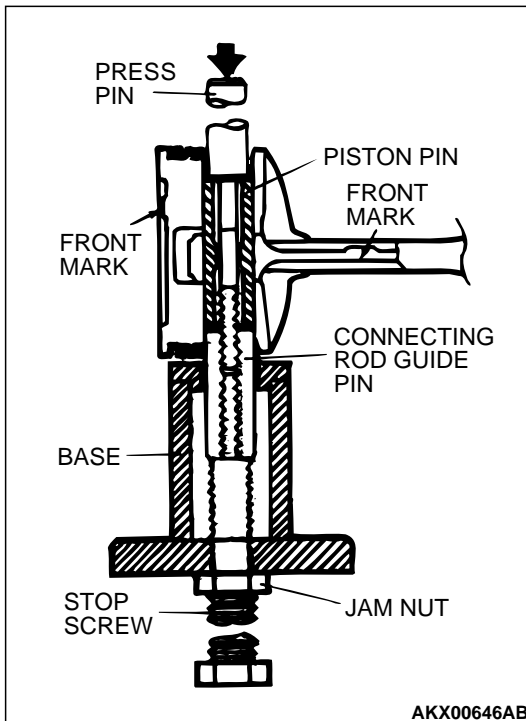
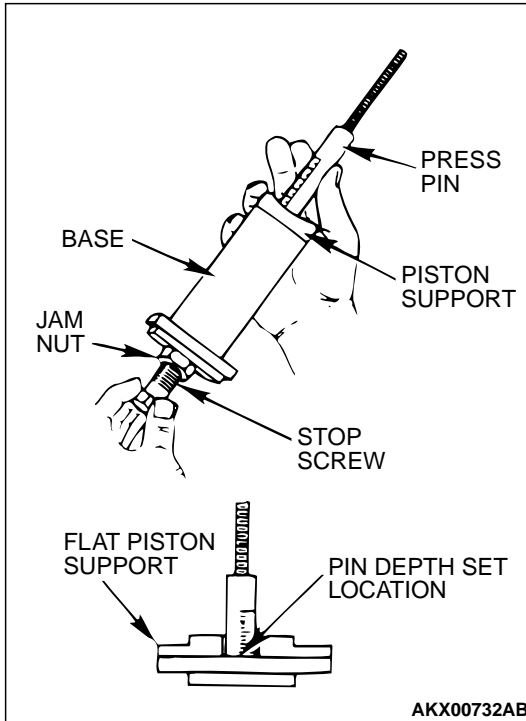

3. Place the base on the press support blocks.
4. Slide the piston pin over the threaded end of the press pin, and thread the correct guide pin up against it.
5. Coat the piston pin with engine oil, and with the connecting rod held in position, slide the guide pin through the piston and connecting rod.
6. Press the piston pin through the connecting rod until the guide pin contacts the stop screw.

CAUTION

Due to production tolerance variations, it is necessary to visually inspect the piston pin depth after installation to verify that the piston pin is centered. Adjust if necessary.

7. Remove the piston assembly from the base. Remove the guide pin and press pin from the assembly.

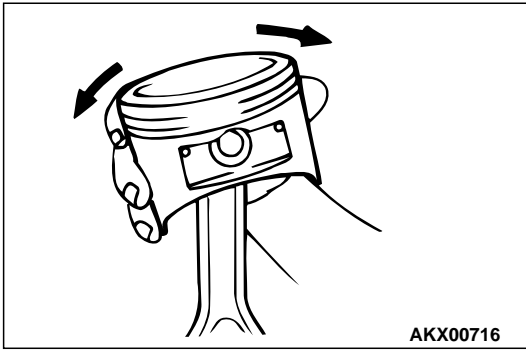

8. Check that the piston moves smoothly.

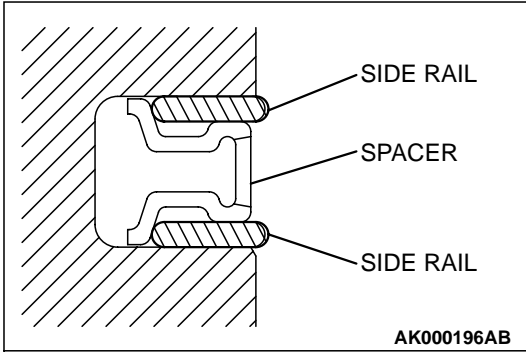

>>B<< OIL RING INSTALLATION

1. Fit the oil ring spacer into the piston ring groove.

NOTE: The side rails and spacer may be installed in either direction.

NOTE: New spacers and side rails are colored for identification of their sizes.

SIZE	COLOR
Standard	None
0.50 mm (0.020 in) oversize	Blue
1.00 mm (0.040 in) oversize	Yellow

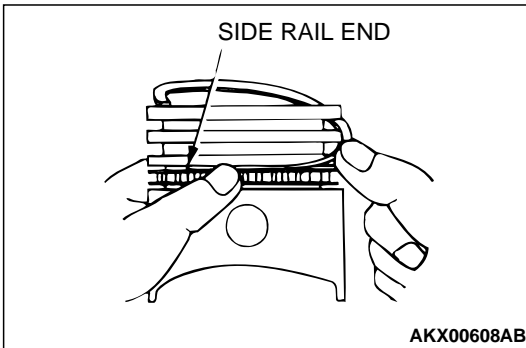

⚠ CAUTION

Do not use any piston ring expander when installing the side rail.

2. Install the upper side rail

To install the side rail, first fit one end of the rail into the piston groove, then press the remaining portion into the position by finger. See illustration.

3. Install the lower side rail in the same procedure as described in step 2.

4. Make sure that the side rails move smoothly in either direction.

>>C<< PISTON RING NO.2/PISTON RING NO.1
INSTALLATION

1. To prevent wrong installation, check the identification mark of each piston ring. The identification mark is stamped near the ring gap:

Identification mark
Number 1 ring: T
Number 2 ring: 2T

NOTE: Size marks on piston rings are as follows.

SIZE	SIZE MARK
Standard	None
0.50 mm (0.020 in) oversize	50
1.00 mm (0.040 in) oversize	100

2. Using a piston ring expander, fit the number 2 piston ring into the number 2 groove of piston.
NOTE: Install the piston rings with their identification mark facing up, to the piston crown side.
3. Install the number 1 piston ring in the same manner as step 2.

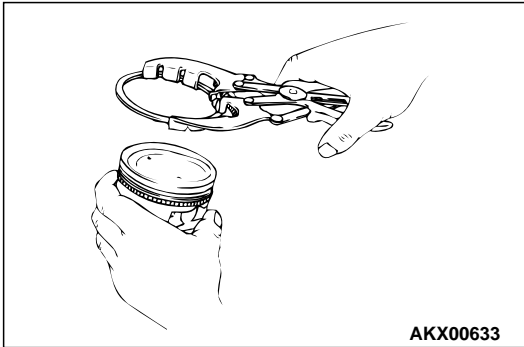
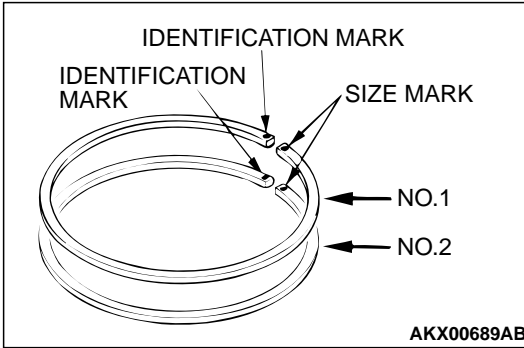

>>D<< PISTON AND CONNECTING ROD INSTALLATION

1. Apply engine oil on the circumference of the piston, piston rings, and oil ring.
2. Arrange the piston ring and oil ring gaps (side rail and spacer) as shown in the illustration.
3. Rotate the crankshaft so that the crank pin is on the center of the cylinder bore.

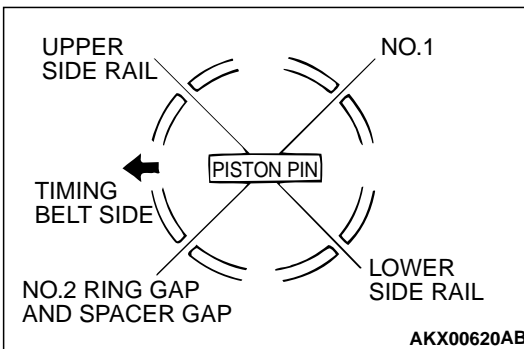

4. Use suitable thread protectors on the connecting rod bolts before inserting the piston and connecting rod assembly into the cylinder block.
 Care must be taken not to nick the crank pin.
5. Insert the piston and connecting rod assembly into the cylinder with the front mark on the piston crown pointing to the timing belt side.
6. Using a suitable piston ring compressor tool, install the piston and connecting rod assembly into the cylinder block.

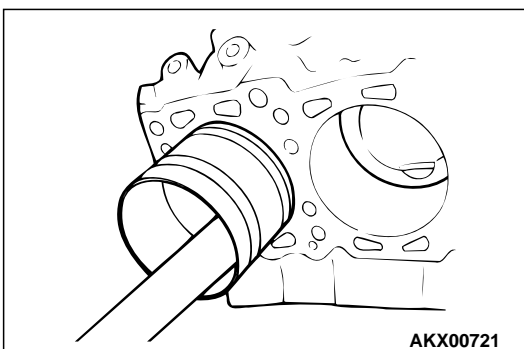

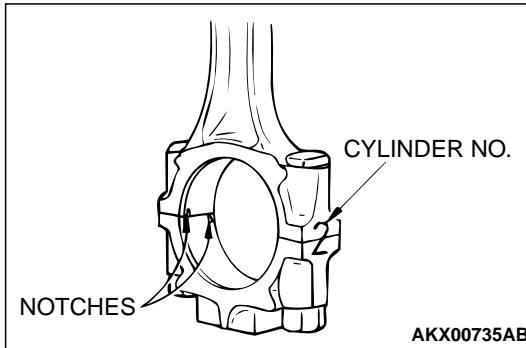
**>>E<< CONNECTING ROD CAP INSTALLATION**

1. Mate the correct bearing cap with the correct connecting rod by checking with the alignment marks marked during disassembly. If a new connecting rod is used which has no alignment mark, position the notches for locking the bearing on the same side.

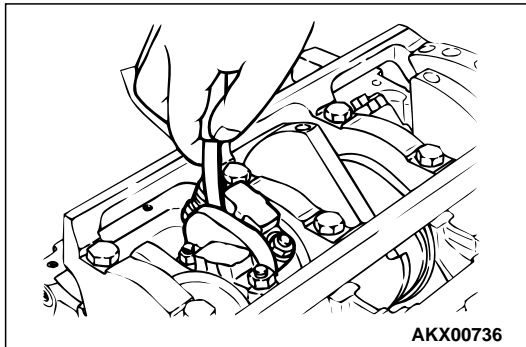

2. Check if the thrust clearance in the connecting rod big end is correct.

Standard value: 0.10 – 0.25 mm (0.004 – 0.009 inch)

Limit: 0.4 mm (0.02 inch)

INSPECTION

M1113008500042

PISTON

Replace the piston if scratches or seizure is evident on its surfaces (especially the thrust surface). Replace the piston if it is cracked.

PISTON PIN

1. Insert the piston pin into the piston pin hole with your thumb. You should feel a slight resistance. Replace the piston pin if it can be easily inserted or there is an excessive play.
2. The piston and piston pin must be replaced as an assembly.

PISTON RING

1. Check the piston ring for damage, excessive wear, and breakage. Replace if defects are evident. If the piston has been replaced, the piston rings must also be replaced.
2. Check for clearance between the piston ring and ring groove. If it exceeds the limit, replace the ring or piston, or both.

Standard value:

Number 1 0.03 – 0.07 mm (0.0012 – 0.0027 inch)

Number 2 0.02 – 0.06 mm (0.0008 – 0.0023 inch)

Limit: 0.1 mm (0.003 inch)

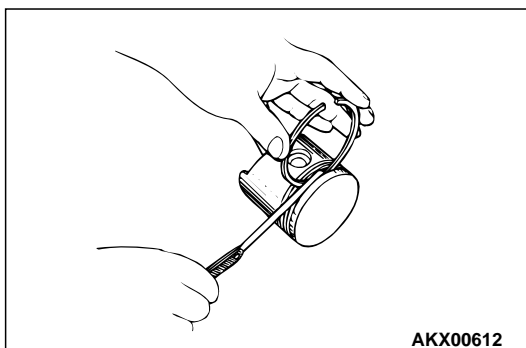

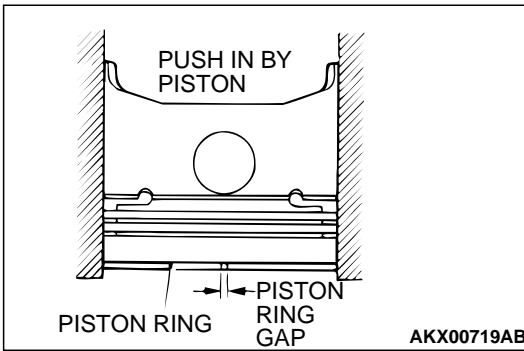

3. Insert the piston ring into the cylinder bore. Force the ring down with a piston, the piston crown being in contact with the ring, to correctly position it at right angles to the cylinder wall. Then, measure the end gap with a feeler gauge. If the ring gap is excessive, replace the piston ring.

Standard value:

Number 1: 0.30 – 0.45 mm (0.012 – 0.017 inch)

Number 2: 0.45 – 0.60 mm (0.018 – 0.023 inch)

Oil: 0.20 – 0.60 mm (0.008 – 0.023 inch)

Limit:

Number 1, Number 2: 0.8 mm (0.03 inch)

Oil: 1.0 mm (0.03 inch)

CRANKSHAFT PIN OIL CLEARANCE (PLASTIC GAUGING MATERIAL METHOD)

1. Remove oil from the crankshaft pin and the connecting rod bearing.
2. Cut plastic gauging material to the same length as the width of the bearing and place it on the pin in parallel with its axis.
3. Install the connecting rod cap carefully and tighten the nuts to the specified torque.
4. Carefully remove the connecting rod cap.
5. Measure the width of the plastic gauging material at its widest part by using a scale printed on the plastic gauging material package.

Standard value: 0.02 – 0.05 mm (0.0008 – 0.0019 inch)

Limit: 0.1 mm (0.003 inch)

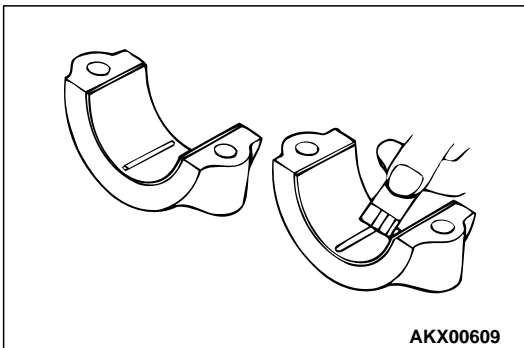
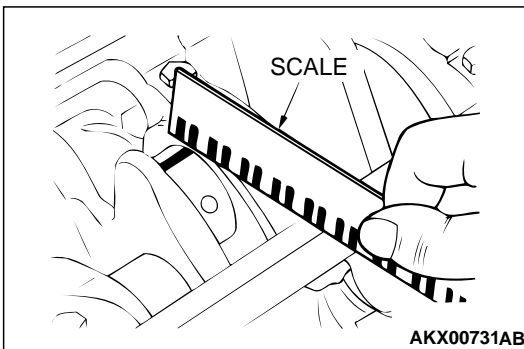

CRANKSHAFT AND CYLINDER BLOCK

REMOVAL AND INSTALLATION

M1113008700121

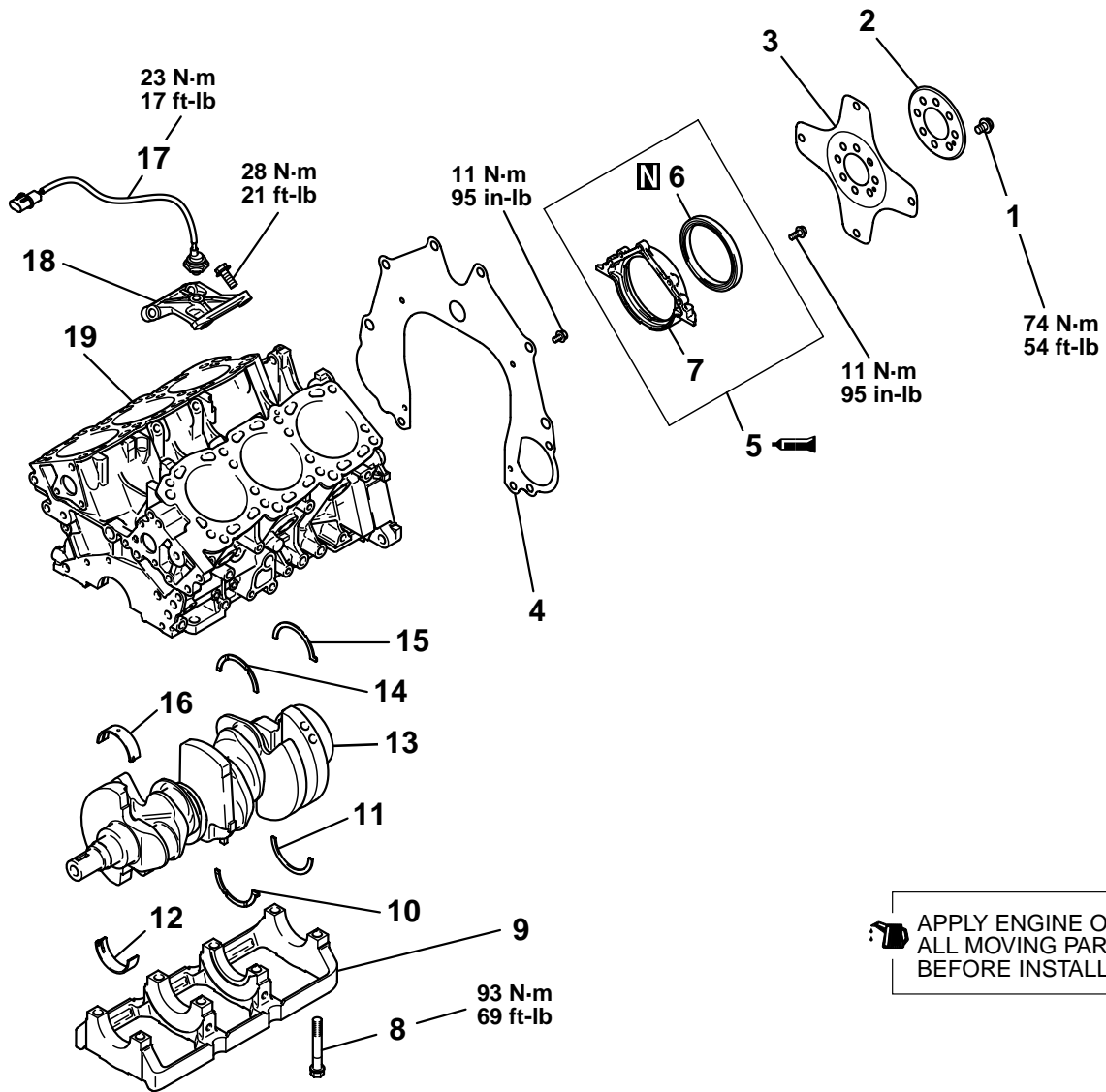

 APPLY ENGINE OIL TO ALL MOVING PARTS BEFORE INSTALLATION.

AK000426AC

REMOVAL STEPS

- 1. DRIVE PLATE BOLT
- 2. ADAPTOR PLATE
- 3. DRIVE PLATE
- 4. REAR PLATE
- >>F<< 5. OIL SEAL CASE ASSEMBLY
- >>E<< 6. CRANKSHAFT REAR OIL SEAL
- 7. OIL SEAL CASE
- >>D<< 8. BEARING CAP BOLT
- >>D<< 9. BEARING CAP
- >>C<< 10. THRUST BEARING A

REMOVAL STEPS (Continued)

- >>C<< 11. THRUST BEARING B
- >>B<< 12. CRANKSHAFT BEARING, LOWER
- 13. CRANKSHAFT
- >>C<< 14. THRUST BEARING B
- >>C<< 15. THRUST BEARING A
- >>B<< 16. CRANKSHAFT BEARING, UPPER
- 17. KNOCK SENSOR
- >>A<< 18. KNOCK SENSOR BRACKET
- 19. CYLINDER BLOCK

Required Special Tool:

MD998718: Crankshaft Rear Oil Seal Installer

TSB Revision

INSTALLATION SERVICE POINTS

>>A<< KNOCK SENSOR BRACKET INSTALLATION

Check that the bracket is in proper contact with the cylinder block boss and tighten to the specified torque in the order shown.

Tightening torque: 28 N·m (21 ft·lb)

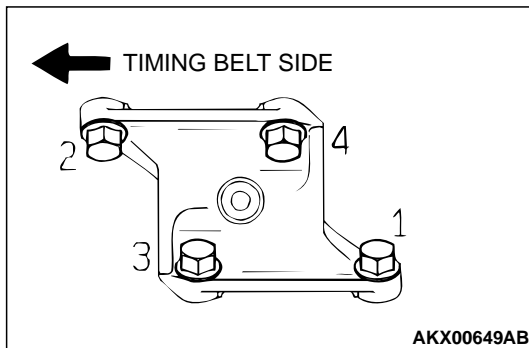

>>B<< CRANKSHAFT BEARING INSTALLATION

When bearing replacement is required, select and install the correct bearing by the following procedure.

1. Measure the crankshaft journal diameter and confirm its classification from the following table. In the case of a crankshaft supplied as a service part, identification colours/marks of its journals are painted/stamped at the positions shown in the illustration.
2. The cylinder block bearing bore diameter identification marks are stamped at the position shown in the illustration from left to right, bearing at No.1.

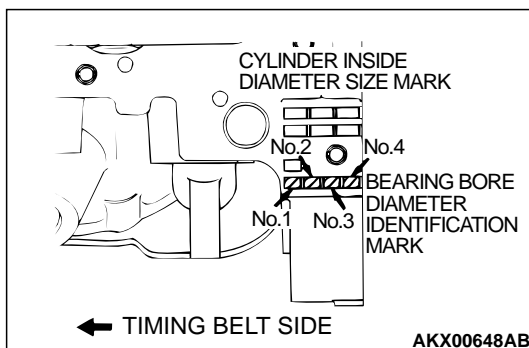
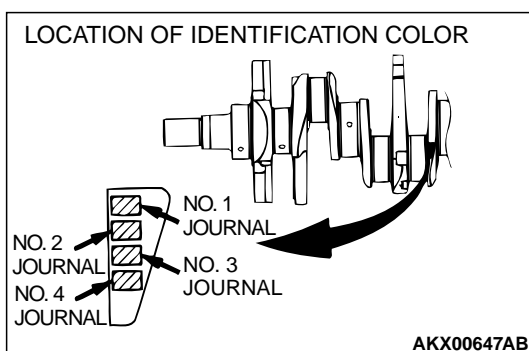

CRANKSHAFT JOURNAL OUTSIDE DIAMETER		CYLINDER BLOCK BEARING BORE	CRANKSH AFT BEARING
ID COLOR	SIZE mm (inch)	ID MARK	ID COLOR
Yellow	59.990 – 59.996 (2.3618 – 2.3620)	I	Pink
		II	Red
		III	Green
None	59.984 – 59.990 (2.3616 – 2.3618)	I	Red
		II	Green
		III	Black
White	59.978 – 59.984 (2.3613 – 2.3616)	I	Green
		II	Black
		III	Brown

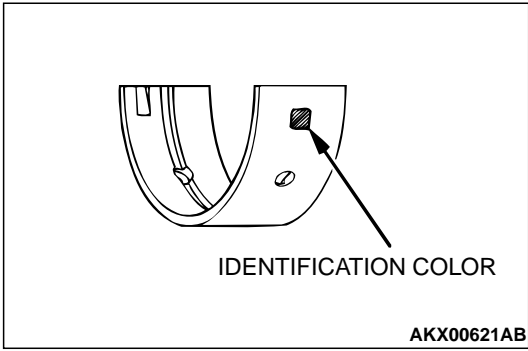

3. For example, if the crankshaft journal outside diameter ID color is "Yellow " and the cylinder block bearing bore ID mark is "III," select a bearing whose ID color is "Green." If there is no ID color paint on the crankshaft, measure the journal outside diameter and select a bearing appropriate for the measured value.

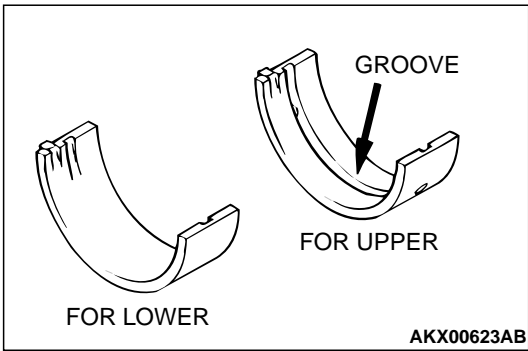

4. Install the bearings having a groove to the cylinder block.
5. Install the bearings having no groove to the bearing cap.

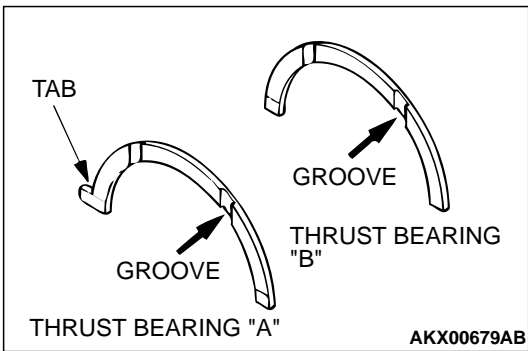

>>C<< CRANKSHAFT THRUST BEARING INSTALLATION

1. Install the thrust bearings in the number 3 bearing bore in the cylinder block and in the bearing cap. For easier installation, apply engine oil to the bearings; this will help hold them in position.
2. The thrust bearings must be installed with their groove toward the crankshaft web. The two thrust bearings are different from each other. One has a tab while the other has no tab. Be careful not to confuse them.

>>D<<BEARING CAP/BEARING CAP BOLT INSTALLATION

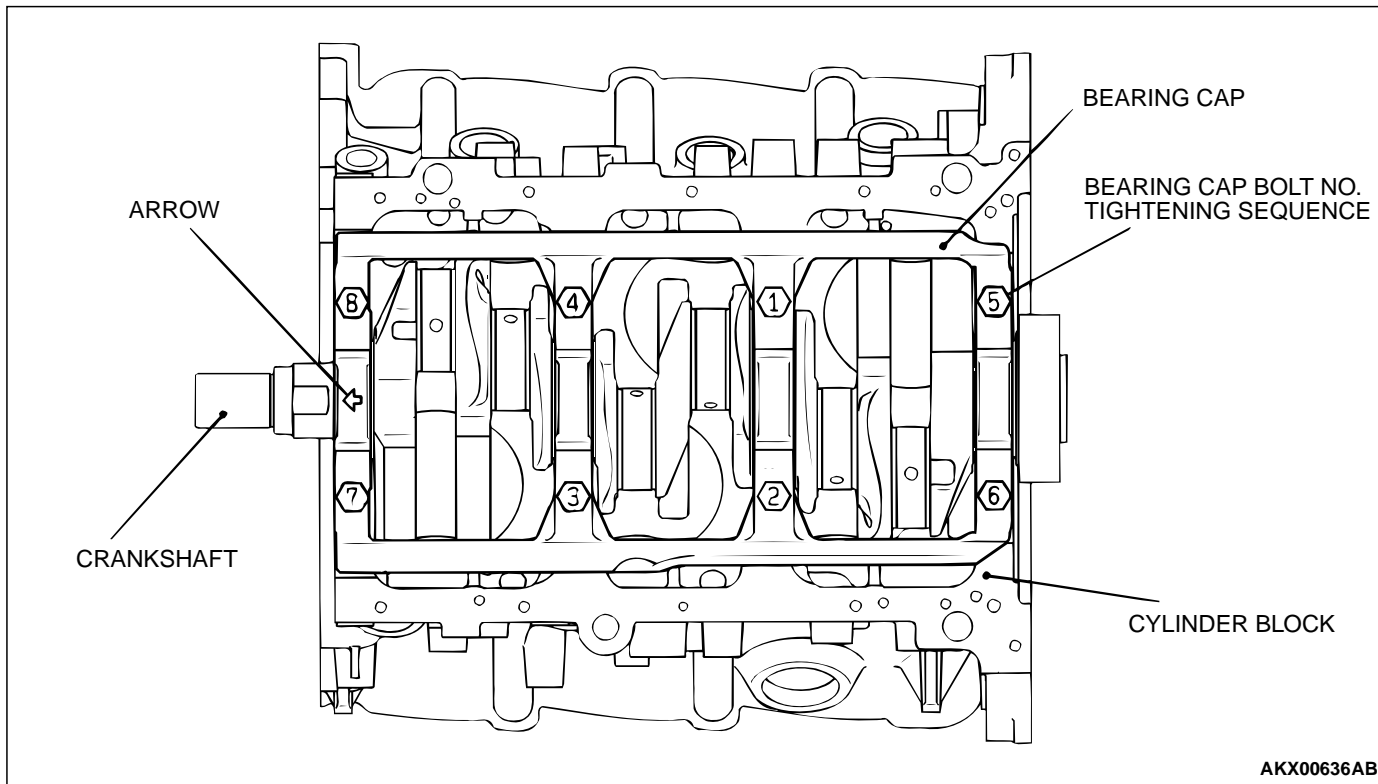

1. Install the bearing cap on the cylinder block, so that the arrow points to the timing belt side.
2. Tighten the bearing cap bolts to 93 N·m (69 ft·lb) in the specified tightening sequence.
3. Check that the crankshaft rotates smoothly.
4. Check the end play. If it exceeds the limit value, replace the thrust bearing.

Standard value : 0.05 – 0.25 mm (0.002 – 0.009 inch)
Limit: 0.3 mm (0.01 inch)

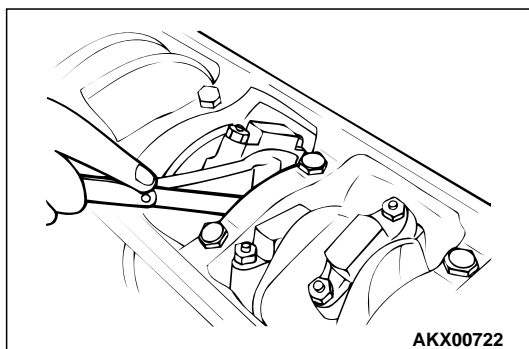

>>E<< CRANKSHAFT REAR OIL SEAL INSTALLATION

Using special tool MD998718, press-fit a new crankshaft rear oil seal into the oil seal case.

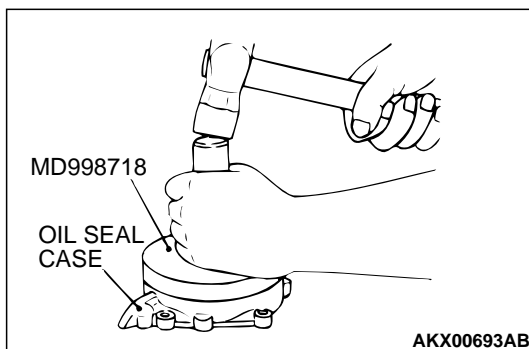

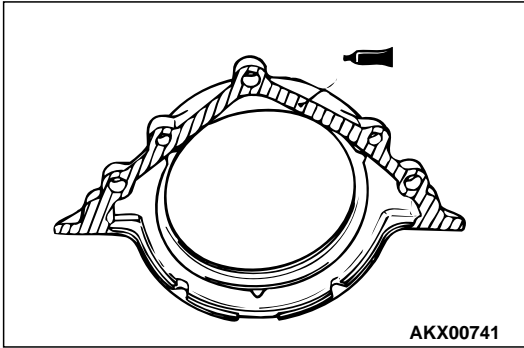
**>>F<< OIL SEAL CASE ASSEMBLY INSTALLATION**

1. Apply sealant Mitsubishi Genuine Part number MD970389 or equivalent to the gasket surface of oil seal case.
NOTE: Be sure to install the case quickly while the sealant is wet (within 15 minutes).
2. Apply engine oil to the lip of the oil seal, and then install the oil seal case onto the cylinder block.
NOTE: After installation, keep the sealed area away from the oil for approximately one hour.

INSPECTION

M1113008800043

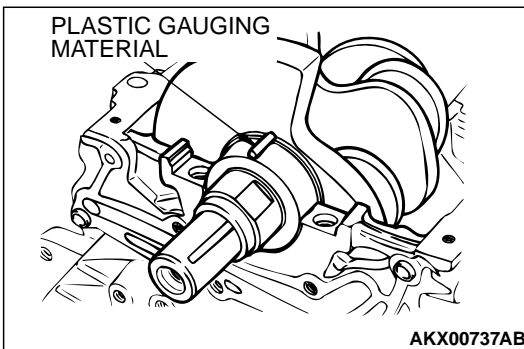
CRANKSHAFT JOURNAL OIL CLEARANCE (PLASTIC GAUGING MATERIAL METHOD)

1. Remove oil from the crankshaft journal and crankshaft bearing.
2. Install the crankshaft.
3. Cut plastic gauging material to the same length as the width of the bearing and place it on the journal in parallel with its axis.

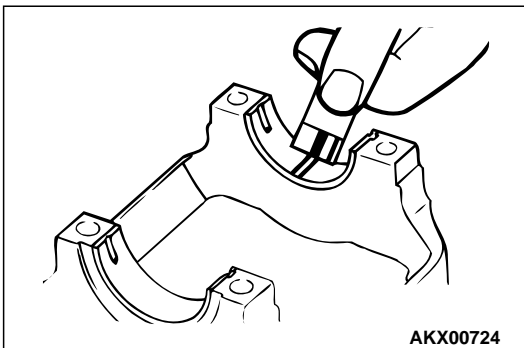

4. Install the crankshaft bearing cap carefully and tighten the bolts to the specified torque.
5. Carefully remove the crankshaft bearing cap.
6. Measure the width of the plastic gauging material at its widest part by using a scale printed on the plastic gauging material package.

Standard value: 0.02 – 0.04 mm (0.0008 – 0.0015 inch)
Limit: 0.1 mm (0.003 inch)

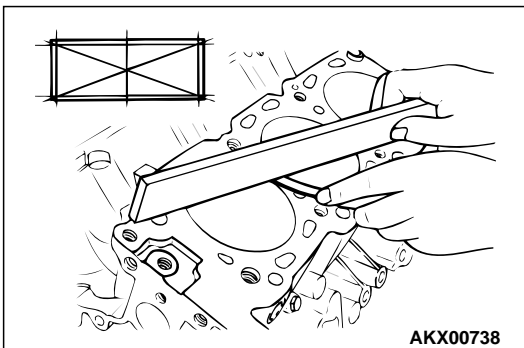
**CYLINDER BLOCK**

1. Visually check for scratches, rust, and corrosion. Use also a flaw detecting agent for the check. If defects are evident, correct, or replace.
2. Using a straightedge and feeler gauge, check the block top surface for warpage. Make sure that the surface is free from gasket chips and other foreign matter.

Standard value: 0.05 mm (0.002 inch)
Limit: 0.1 mm (0.003 inch)

3. If the distortion is excessive, correct within the allowable limit or replace.

Grinding limit: 0.2 mm (0.008 inch)

***Includes/combined with cylinder head grinding.**

**Cylinder block height (when new):
210.5 mm (8.29 inches)**

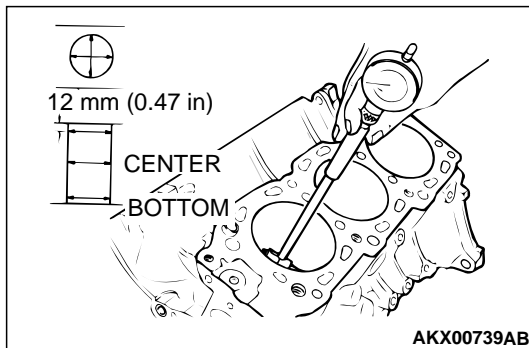

4. Check the cylinder walls for scratches and seizure. If defects are evident, replace or bore to oversize and replace pistons and piston rings.
5. Using a cylinder gauge, measure the cylinder bore and cylindricity. If worn badly, correct by boring the cylinders to an oversize and replace pistons and piston rings. Measure at the points shown in the illustration.

Standard value:

Cylinder Inside Diameter: 91.1 mm (3.59 inches)
Cylindricity: 0.01 mm (0.0003 inch)

BORING CYLINDER

1. Oversize pistons to be used should be determined on the basis of the largest bore cylinder.

Piston size identification

SIZE	IDENTIFICATION MARK
0.50 mm (0.02 in) Oversize diameter	0.50
1.00 mm (0.04 in) Oversize diameter	1.00

NOTE: Size mark is stamped on the piston top.

2. Measure the outside diameter of the piston to be used. Measure it in the thrust direction as shown.
3. Based on the measured piston Outside Diameter (OD), calculate the boring finish dimension.

Boring finish dimension =

Piston OD + (clearance between piston OD and cylinder) – 0.02 mm (0.0008 inch) (honing margin)

⚠ CAUTION

To prevent distortion that may result from temperature rise during honing, bore cylinders in the order of number 2, number 4, number 6, number 1, number 3 and number 5.

4. Bore all cylinders to the calculated boring finish dimension.
- 5.hone to the final finish dimension (piston OD + clearance between piston OD and cylinder).
6. Check the clearance between the piston and cylinder.

Clearance between piston and cylinder:

0.02 – 0.04 mm (0.0008 - .0015 inch)

NOTE: When boring cylinders, finish all of six cylinders to the same oversize. Do not bore only one cylinder to an oversize.

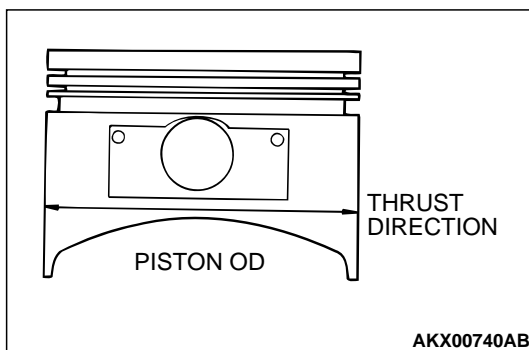

SPECIFICATIONS

FASTENER TIGHTENING SPECIFICATIONS

M1113023400105

ITEMS	SPECIFICATIONS
Generator and drive belt	
Crankshaft bolt	181 N·m (134 ft-lb)
Dipstick guide bolt	48 N·m (35 ft-lb)
Drive belt tensioner pulley nut	49 N·m (36 ft-lb)
Generator bolt nut	44 N·m (33 ft-lb)
Generator bolt M8	22 N·m (16 ft-lb)
Generator bracket bolt	49 N·m (36 ft-lb)
Intake manifold plenum and throttle body	
Exhaust gas recirculation pipe bolt	18 N·m (13 ft-lb)
Exhaust gas recirculation pipe flare nut	59 N·m (43 ft-lb)
Exhaust gas recirculation valve bolt	22 N·m (16 ft-lb)
Intake manifold plenum stay M8	18 N·m (13 ft-lb)
Intake manifold plenum bolt and nut	18 N·m (13 ft-lb)
Intake manifold plenum stay M10	35 N·m (26 ft-lb)
Manifold differential pressure sensor	4.9 N·m (43 in-lb)
Throttle body bolt	12 N·m (104 in-lb)
Ignition system	
Distributor	13 N·m (113 in-lb)
Spark plugs	25 N·m (18 ft-lb)
Timing belt	
Auto tensioner bolt	24 N·m (17 ft-lb)
Bracket	24 N·m (17 ft-lb)
Camshaft sprocket bolt	88 N·m (65 ft-lb)
Crankshaft position sensor bolt	8.8 N·m (78 in-lb)
Engine support bracket	44 N·m (33 ft-lb)
Idler pulley bolt	44 N·m (33 ft-lb)
Tensioner pulley bolt	48 N·m (35 ft-lb)
Tensioner arm bolt	44 N·m (33 ft-lb)
Timing belt cover bolt M6	11 N·m (95 in-lb)
Timing belt cover bolt M8	14 N·m (122 in-lb)
Timing belt rear cover bolt	14 N·m (122 in-lb)
Intake manifold and fuel parts	
Fuel rail bolt	12 N·m (104 in-lb)
Fuel pressure regulator bolt	8.8 N·m (78 in-lb)
Intake manifold nut	22 N·m (16 ft-lb)
Water pump and water pipes	
Engine coolant temperature gauge unit	11 N·m (95 in-lb)

TSB Revision

ITEMS	SPECIFICATIONS
Engine coolant temperature sensor	29 N·m (22 ft-lb)
Heater pipe bolt	19 N·m (14 ft-lb)
Thermostat housing bolt	19 N·m (14 ft-lb)
Water inlet fitting bolt	19 N·m (14 ft-lb)
Water inlet pipe bolt	14 N·m (122 in-lb)
Water outlet fitting bolt	19 N·m (14 ft-lb)
Water pump bolt M8	24 N· (17 ft-lb)
Water pump bolt M10	41 N·m (30 ft-lb)
Exhaust manifold	
Engine hanger	35 N·m (26 ft-lb)
Exhaust manifold nut	44 N·m (33 ft-lb)
Heat protector bolt	14 N·m (122 in-lb)
Oxygen sensor	44 N·m (33 ft-lb)
Rocker arms and camshaft	
Rocker cover bolt	3.4 N·m (30 in-lb)
Rocker shaft bolt	31 N·m (23 ft-lb)
Thrust case bolt	13 N·m (113 in-lb)
Cylinder head and valve	
Cylinder head bolt	108 N·m (80 ft-lb) to back of to 108 N·m (80 ft-lb)
Oil pan and oil pump	
Baffle plate bolt (Cylinder block side)	8.8 N·m (78 in-lb)
Baffle plate bolt (Oil pan side)	11 N·m (95 in-lb)
Cover bolt	11 N·m (95 in-lb)
Drain plug	39 N·m (29 ft-lb)
Oil filter bracket bolt	24 N·m (17 ft-lb)
Oil pan, lower bolt	11 N·m (95 in-lb)
Oil pan, upper bolt	5.9 N·m (52 in-lb)
Oil pressure switch	10 N·m (87 in-lb)
Oil pump case bolt M8	14 N·m (122 in-lb)
Oil pump cover bolt	10 N·m (87 in-lb)
Oil pump cover bolt M10	41 N·m (30 ft-lb)
Oil screen bolt	19 N·m (14 ft-lb)
Relief plug	44 N·m (33 ft-lb)
Piston and connecting rod	
Connecting rod cap nut	51 N·m (38 ft-lb)
Crankshaft and cylinder block	
Bearing cap bolt	93 N·m (69 ft-lb)
Drive plate bolt	74 N·m (54 ft-lb)
Knock sensor	23 N·m (17 ft-lb)

ITEMS	SPECIFICATIONS
Knock sensor bracket	28 N·m (22 ft-lb)
Oil seal case bolt	11 N·m (95 in-lb)
Rear plate bolt	11 N·m (95 in-lb)

GENERAL SPECIFICATIONS

M1113000200081

DESCRIPTIONS		SPECIFICATIONS	
Type		60° OHV, SOHC	
Number of cylinders		6	
Combustion chamber		Compact type	
Total displacement dm ³ (cu in)		2.972 (181.4)	
Cylinder bore (in)		91.1 (3.59)	
Piston stroke mm (in)		76.0 (2.99)	
Compression ratio		8.9	
Valve timing	Intake valve	Opens (BTDC)	15°
		Closes (ABDC)	53°
	Exhaust valve	Opens (BBDC)	53°
		Closes (ATDC)	15°
Lubrication system		Pressure feed, full-flow filtration	
Oil pump type		Trochoid type	

SERVICE SPECIFICATIONS

M1113000300066

ITEM	STANDARD VALUE		LIMIT
Timing belt			
Auto-tensioner rod length mm (in)	3.8 – 5.0 (0.15 – 0.20)		-
Auto-tensioner rod production length mm (in)	12 (0.5)		-
Auto-tensioner rod pushed-in amount [when pushed with a force of 98 – 196 N (22 – 44 lbs)] mm (in)	1.0 (0.03) or less		-
Rocker arms and camshaft			
Camshaft cam height mm (in)	Intake	37.71 (1.485)	Minimum 37.21 (1.465)
	Exhaust	37.14 (1.462)	Minimum 36.64 (1.443)
Camshaft journal outside diameter mm (in)	45 (1.8)		-
Cylinder head and valves			
Cylinder head flatness of gasket surface mm (in)	Less than 0.03 (0.001)		0.2 (0.007)
Cylinder head grinding limit of gasket surface mm (in) Total resurfacing depth of cylinder head and cylinder block	-		0.2 (0.007)
Cylinder head overall height mm (in)	120 (4.7)		-
Valve thickness of valve head (margin) mm (in)	Intake	1.0 (0.04)	Minimum 0.5 (0.02)
	Exhaust	1.2 (0.05)	Minimum 0.7 (0.03)

ITEM		STANDARD VALUE	LIMIT
Valve overall height mm (in)	Intake	112.30 (4.421)	Minimum 111.80 (4.402)
	Exhaust	114.11 (4.493)	Minimum 113.61 (4.473)
Valve stem outside diameter mm (in)	Intake	6.0 (0.24)	-
	Exhaust	6.0 (0.24)	-
Valve thickness to valve guide clearance mm (in)	Intake	0.02 – 0.05 (0.0008 – 0.0019)	0.10 (0.003)
	Exhaust	0.04 – 0.07 (0.0016 – 0.0027)	0.15 (0.005)
Valve face angle mm (in)		45° – 4.5°	-
Valve spring free length mm (in)		51.0 (2.01)	Minimum 50.0 (1.97)
Valve spring load/installed height N (lb)/mm (in)		267/44.2 (60.0/1.74)	-
Valve spring out-of-squareness		2° or less	4°
Valve seat valve contact width mm (in)		0.9 – 1.3 (0.04 – 0.05)	-
Valve guide inside diameter mm (in)		6.0 (0.32)	-
Valve guide projection from cylinder head upper surface mm (in)		14 (0.6)	-
Valve stem projection mm (in)		49.30 (1.941)	49.80 (1.960)
Oversize rework dimensions of valve guide hole mm (in)	0.05 oversize diameter	11.05 – 11.07 (0.4351 – 0.4358)	-
	0.25 oversize diameter	11.25 – 11.27 (0.4429 – 0.4437)	-
	0.50 oversize diameter	11.50 – 11.52 (0.4528 – 0.4535)	-
Intake oversize rework dimensions of valve seat hole mm (in)	0.3 oversize diameter	34.30 – 34.33 (1.3504 – 1.3515)	-
	0.6 oversize diameter	34.60 – 34.63 (1.3623 – 1.3633)	-
Exhaust oversize rework dimensions of valve seat hole mm (in)	0.3 oversize diameter	31.80 – 31.81 (1.2520 – 1.2531)	-
	0.6 oversize diameter	32.10 – 32.13 (1.2638 – 1.2650)	-
Oil pan and oil pump			
Oil pump tip clearance mm (in)		0.06 – 0.18 (0.003 – 0.007)	-
Oil pump side clearance mm (in)		0.04 – 0.10 (0.002 – 0.003)	-
Oil pump body clearance mm (in)		0.10 – 0.18 (0.004 – 0.007)	0.35 (0.013)
Oil pressure at curb idle speed kPa (psi) [oil temperature is 75 to 90°C (167 to 194°F)]		80 (11.6) or more	-
Piston and connecting rod			
Piston outside diameter mm (in)		91.1 (3.58)	-
Piston ring to ring groove clearance mm (in)	No.1	0.03 – 0.07 (0.0012 – 0.0027)	0.1 (0.003)
	No.2	0.02 – 0.06 (0.0008 – 0.0023)	0.1 (0.003)

ITEM		STANDARD VALUE	LIMIT
Piston ring end gap mm (in)	No.1	0.30 – 0.45 (0.012 – 0.017)	0.8 (0.03)
	No.2	0.45 – 0.60 (0.018 – 0.023)	0.8 (0.03)
	Oil ring side rail	0.20 – 0.60 (0.008 – 0.023)	1.0 (0.03)
Piston pin outside diameter mm (in)		22.0 (0.87)	-
Piston pin press-in load N (lbs) (room temperature)		7,350 – 17,200 (1,653 – 3,866)	-
Crankshaft pin oil clearance mm (in)		0.02 – 0.05 (0.0008 – 0.0019)	0.1 (0.003)
Connecting rod big end side clearance mm (in)		0.10 – 0.25 (0.003 – 0.009)	0.4 (0.02)
Crankshaft and cylinder block			
Crankshaft end play mm (in)		0.05 – 0.25 (0.002 – 0.009)	0.3 (0.01)
Crankshaft journal outside diameter mm (in)		60 (2.4)	-
Crankshaft pin outside diameter mm (in)		50 (2.0)	-
Crankshaft journal oil clearance mm (in)		0.02 – 0.04 (0.0008 – 0.0015)	0.1 (0.003)
Piston to cylinder clearance mm (in)		0.02 – 0.04 (0.0008 – 0.0015)	-
Cylinder block flatness of gasket surface mm (in)		0.05 (0.02)	0.1 (0.003)
Cylinder block grinding limit of gasket surface mm (in) total resurfacing depth of both cylinder head and cylinder block		-	0.2 (0.008)
Cylinder block overall height mm (in)		210.5 (8.29)	-
Cylinder bore inside diameter mm (in)		91.1 (3.59)	-
Cylindricity mm (in)		0.01 (0.0003)	-

SEALANTS AND ADHESIVES

M1113000500060

ITEM	SPECIFIED SEALANT	QUANTITY
Engine coolant temperature sensor	3M™ AAD Part No. 8731 or equivalent	As required
Engine coolant temperature gauge unit	3M™ AAD Part No. 8672 or equivalent	As required
Oil pressure switch	3M™ AAD Part No. 8672 or equivalent	As required
Oil pump case	MITSUBISHI Genuine part No. MD970389 or equivalent	As required
Oil pan	MITSUBISHI Genuine part No. MD970389 or equivalent	As required
Oil seal case	MITSUBISHI Genuine part No. MD970389 or equivalent	As required