

## GROUP 16

# ENGINE ELECTRICAL

## CONTENTS

<b>CHARGING SYSTEM . . . . .</b>	<b>16-3</b>	<b>GENERAL DESCRIPTION . . . . .</b>	<b>16-31</b>
<b>GENERAL DESCRIPTION . . . . .</b>	16-3	<b>SPECIAL TOOLS . . . . .</b>	16-32
<b>CHARGING SYSTEM DIAGNOSIS</b>	16-4	<b>ON-VEHICLE SERVICE . . . . .</b>	16-33
<b>SPECIAL TOOL . . . . .</b>	16-6	SPARK PLUG CABLE TEST . . . . .	16-33
<b>ON-VEHICLE SERVICE . . . . .</b>	16-6	IGNITION COIL CHECK <2.4L> . . . . .	16-33
GENERATOR OUTPUT LINE VOLTAGE DROP TEST . . . . .	16-6	IGNITION COIL CHECK <3.0L> . . . . .	16-34
OUTPUT CURRENT TEST . . . . .	16-8	IGNITION COIL POWER TRANSISTOR CONTINUITY CHECK . . . . .	16-34
REGULATED VOLTAGE TEST . . . . .	16-10	IGNITION FAILURE SENSOR CHECK . . . . .	16-34
WAVE PATTERN CHECK USING AN OSCILLOSCOPE . . . . .	16-11	SPARK PLUG CABLE RESISTANCE CHECK . . . . .	16-35
<b>GENERATOR ASSEMBLY . . . . .</b>	16-13	SPARK PLUG TEST . . . . .	16-35
REMOVAL AND INSTALLATION . . . . .	16-13	SPARK PLUG CHECK AND CLEANING <2.4L> . . . . .	16-35
DISASSEMBLY AND ASSEMBLY . . . . .	16-16	SPARK PLUG CHECK AND CLEANING <3.0L> . . . . .	16-36
INSPECTION . . . . .	16-18	CAMSHAFT POSITION SENSOR CHECK . . . . .	16-36
<b>STARTING SYSTEM . . . . .</b>	<b>16-20</b>	CRANK ANGLE SENSOR CHECK <2.4L> . . . . .	16-36
<b>GENERAL DESCRIPTION . . . . .</b>	16-20	CRANK ANGLE SENSOR CHECK <3.0L> . . . . .	16-36
<b>STARTER MOTOR ASSEMBLY . . . . .</b>	16-23	IGNITION SECONDARY VOLTAGE WAVE PATTERN CHECK USING AN OSCILLOSCOPE . . . . .	16-36
REMOVAL AND INSTALLATION . . . . .	16-23	IGNITION PRIMARY VOLTAGE WAVE PATTERN CHECK . . . . .	16-43
INSPECTION . . . . .	16-24	<b>IGNITION COIL . . . . .</b>	16-47
DISASSEMBLY AND ASSEMBLY . . . . .	16-27	REMOVAL AND INSTALLATION <2.4L ENGINE> . . . . .	16-47
INSPECTION . . . . .	16-29	DISTRIBUTOR ASSEMBLY . . . . .	16-47
<b>IGNITION SYSTEM . . . . .</b>	<b>16-31</b>		

REMOVAL AND INSTALLATION <3.0L ENGINE> .....	16-47	<b>KNOCK SENSOR</b> .....	16-52
DISASSEMBLY AND ASSEMBLY.....	16-49	REMOVAL AND INSTALLATION <3.0L ENGINE> .....	16-52
<b>CAMSHAFT POSITION SENSOR</b> .....	16-49	<b>SPECIFICATIONS</b> .....	<b>16-53</b>
REMOVAL AND INSTALLATION <2.4L ENGINE>.....	16-49	<b>FASTENER TIGHTENING SPECIFICATIONS</b> .....	16-53
<b>CRANKSHAFT POSITION SENSOR</b>	16-50	<b>GENERAL SPECIFICATIONS</b> .....	16-54
REMOVAL AND INSTALLATION <2.4L ENGINE>.....	16-50	<b>SERVICE SPECIFICATIONS</b> .....	16-54
REMOVAL AND INSTALLATION <3.0L ENGINE>.....	16-51		

# CHARGING SYSTEM

## GENERAL DESCRIPTION

M1161000100061

The charging system charges the battery with the generator output to keep the battery charged at a constant level during varying electrical load.

### Operation

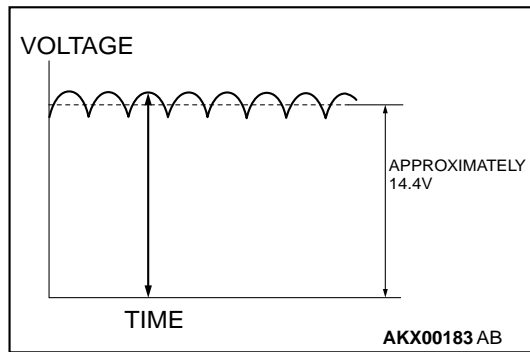

Rotation of the excited field coil generates AC voltage in the stator.

This alternating current is rectified through diodes to DC voltage having a waveform shown in the illustration at left.

The average output voltage fluctuates slightly with the generator load condition.

When the ignition switch is turned on, current flows in the field coil and initial excitation of the field coil occurs.

When the stator coil begins to generate power after the engine is started, the field coil is excited by the output current of the stator coil.

The generator output voltage rises as the field current increases and it falls as the field current decreases. When the battery positive voltage (generator S terminal voltage) reaches a regulated voltage of approximately 14.4V, the field current is cut off. When the battery positive voltage drops below the regulated voltage, the voltage regulator regulates the output voltage to a constant level by controlling the field current.

In addition, when the field current is constant, the generator output voltage rises as the engine speed increases.

<2.4L ENGINE>

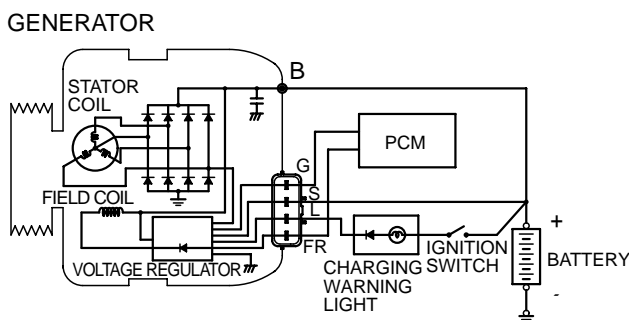

<3.0L ENGINE>

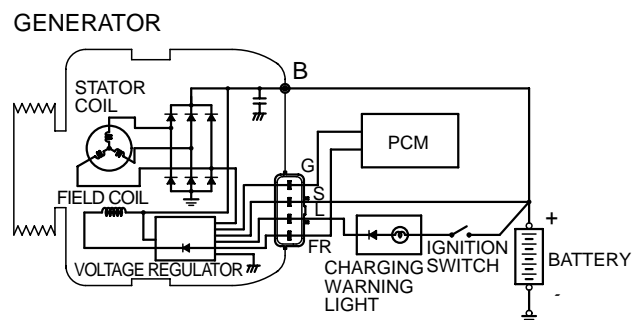

AK000621AB

**CHARGING SYSTEM DIAGNOSIS**

M1161000700063

**TROUBLESHOOTING HINTS**

1. Charging warning light does not go on when the ignition switch is turned to ON, before the engine starts.
  - Check the bulb.
2. Charging warning light does not switch off after the engine starts.
  - Check the I voltage regulator inside the generator.
3. Discharged or overcharged battery.
  - Check the I voltage regulator inside the generator.
4. The charging warning light illuminates dimly.
  - Check the diode (inside the combination meter) for a short-circuit.

**TROUBLESHOOTING GUIDE**

The charging system troubleshooting guide is shown in the following chart.

---

**STEP 1.**

**Q: Is the battery in good condition? (Refer to GROUP 54A, Battery – On-vehicle Service - Battery Check P.54A-5.)**

**YES :** Go to Step 2.

**NO :** Charge or replace the battery.

---

**STEP 2.**

**Q: Is the generator drive belt in good condition? (Refer to GROUP 00, Maintenance Service - Drive Belts P.00-39.)**

**YES :** Go to Step 3.

**NO :** Adjust the belt tension or replace the belt.

---

**STEP 3.**

**Q: Does the charging warning light brightly when the ignition switch is turned on?**

**YES :** Go to Step 4.

- NO :**
- Check the ignition switch. (Refer to GROUP 54A, Ignition switch P.54A-27.)
  - Check for burnt-out charging warning light.
  - Check the generator. (Refer to Generator – Disassembly and assembly – Inspection P.16-18.)
  - Check the charging warning light-related circuits.

---

**STEP 4.**

**Q: Does the charging warning light go out after starting the engine?**

**YES :** Go to Step 5.

**NO :** Check the generator (Refer to Generator – Disassembly and assembly – Inspection P.16-18.)

---

**STEP 5.**

**Q: Is an oscilloscope available?**

**YES :** Go to Step 6.

**NO :** Go to Step 7.

---

**STEP 6.**

**Q: Does the oscilloscope show a normal wave pattern?  
(Refer to Charging system – Wave pattern check using a  
oscilloscope P.16-11.)**

**YES :** Go to Step 7.

**NO :** Check the generator. (Refer to Generator –  
Disassembly and assembly – Inspection P.16-18.)

---

**STEP 7.**

- Engine: 2,500 r/min
- Headlight: ON (high beam)
- Voltage between generator terminal B and the positive battery terminal  
OK: 0.5V or less
- Voltage between the negative battery terminal and generator body  
OK: 0.5V or less

**Q: Are the generator output line and ground line in good condition?**

**YES :** Go to Step 8.

**NO :** Check the generator output line and ground line.

---

**STEP 8.**

**Q: Is the output current normal? (Refer to Charging system – On vehicle service – Output current test P.16-8.)**

**YES :** Go to Step 9.

**NO :** Check the generator (Refer to Generator –  
Disassembly and assembly – Inspection P.16-18.)

---

**STEP 9.**

**Q: Is the regulated voltage normal? (Refer to Charging system – On vehicle service - Regulated voltage test P.16-10.)**

**YES :** Go to Step 10.

**NO :** Check the generator (Refer to Generator –  
Disassembly and assembly – Inspection P.16-18.)

---

**STEP 10.**

**Q: Is the voltage drops in the generator output line normal?**

**YES :** Generator is normal. Check other systems.

**NO :** Check the output line.

SPECIAL TOOL

M1161000600055

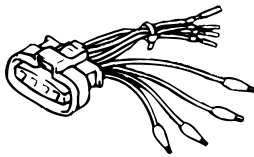
TOOL	TOOL NUMBER AND NAME	SUPERSESSION	APPLICATION
 B991502	MB991502 Scan tool (MUT-II)	MB991496-OD	Checking of engine idle speed
	MB991519 Generator harness connector	Tool not available	Checking of generator (S terminal voltage)

ON-VEHICLE SERVICE

GENERATOR OUTPUT LINE VOLTAGE DROP TEST

M1161000900067

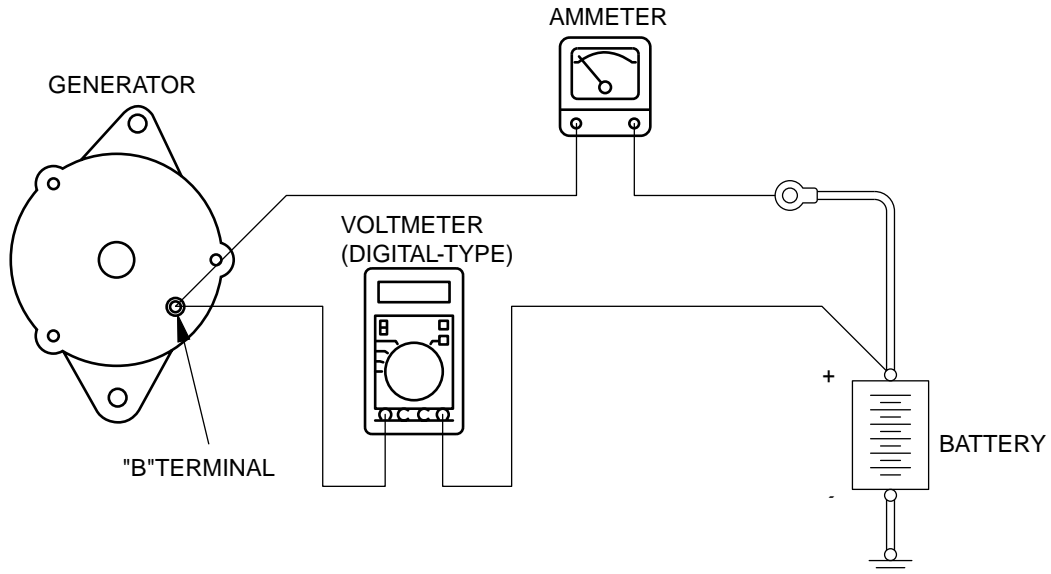

AKX00185 AB

**Required Special Tool:**

MB991502: Scan Tool (MUT-II)

This test determines whether the wiring from the generator "B" terminal to the positive battery terminal (including the fusible link) is in good condition or not:

1. Always be sure to check the following before the test.
  - Generator installation
  - Generator drive belt tension (Refer to GROUP 00, Maintenance Service – Drive Belts P.00-39.)
  - Fusible link

- Abnormal noise from the generator while the engine is running
2. Turn the ignition switch to the "LOCK" (OFF) position.

**⚠ WARNING**

**Battery posts, terminals and related accessories contain lead and lead compounds. WASH HANDS AFTER HANDLING.**

3. Disconnect the negative battery cable.

4. Disconnect the generator output wire from the generator "B" terminal and connect a DC test ammeter with a range of 0 – 100 A in series between the "B" terminal and the disconnected output wire. (Connect the positive lead of the ammeter to the "B" terminal, and then connect the negative lead of the ammeter to the disconnected output wire.)

*NOTE: A clamp-type ammeter which enables measurements to be taken without disconnecting the generator output wire is recommended. If the voltage may have dropped due to a bad connection at generator "B" terminal and the generator "B" terminal is loosened when the test ammeter is connected, the connection will be completed at this time and the possibility of finding the problems will be reduced.*

5. Connect a digital-type voltmeter between the generator "B" terminal and the positive battery terminal. (Connect the positive lead of the voltmeter to the "B" terminal, and then connect the negative lead of the voltmeter to the positive battery cable.)

**⚠ WARNING**

**Battery posts, terminals and related accessories contain lead and lead compounds. WASH HANDS AFTER HANDLING.**

6. Reconnect the negative battery cable.
7. Connect a tachometer or scan tool MB991502.
8. Leave the hood open.
9. Start the engine.
10. With the engine running at 2,500 r/min, turn the headlights and other lights on and off to adjust the generator load so that the value displayed on the ammeter is slightly above 30 A.

**Limit value: maximum 0.3 V**

*NOTE: When the generator output is high and the value displayed on the ammeter does not decrease to 30A, set the value to 40A. Read the value displayed on the voltmeter at this time. In this case the limit value becomes maximum 0.4V.*

*Adjust the engine speed by gradually decreasing it until the value displayed on the ammeter is 30 A. Take a reading of the value displayed on the voltmeter at this time.*

11. If the value displayed on the voltmeter is above the limit value, there is probably a malfunction in the generator output wire. Check the wiring between the generator "B" terminal and the positive battery terminal (including fusible link).  
If a terminal is not sufficiently tight or if the harness has become discolored due to overheating, repair and then test again.
12. After the test, run the engine at idle.
13. Turn off all lights and turn the ignition switch to the "LOCK" (OFF) position.
14. Disconnect the tachometer or scan tool MB991502.

**⚠ WARNING**

**Battery posts, terminals and related accessories contain lead and lead compounds. WASH HANDS AFTER HANDLING.**

15. Disconnect the negative battery cable.
16. Disconnect the ammeter and voltmeter and tachometer.
17. Connect the generator output wire to the generator "B" terminal.

**⚠ WARNING**

**Battery posts, terminals and related accessories contain lead and lead compounds. WASH HANDS AFTER HANDLING.**

18. Connect the negative battery cable.

## OUTPUT CURRENT TEST

M1161001000067

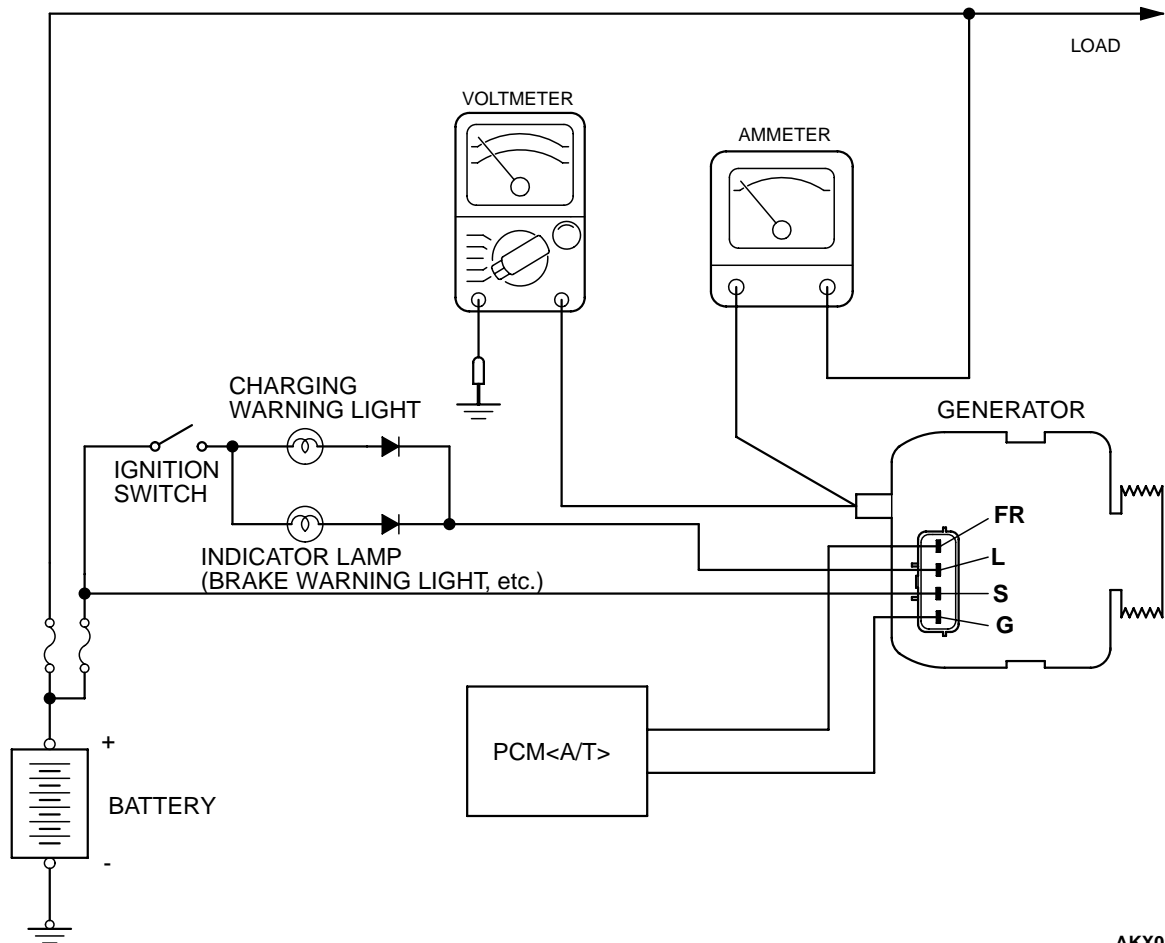

AKX01214 AC

**Required Special Tool:**

MB991502: Scan Tool (MUT-II)

This test determines whether the generator outputs normal current.

- Before the test, always be sure to check the following.
  - Generator installation
  - Battery (Refer to GROUP 54A, Battery – On-vehicle Service – Battery Check P.54A-5.)
 

*NOTE: The battery to be used should be slightly discharged. The load in a fully-charged battery will be insufficient and the test may not be able to be carried out correctly.*
  - Generator drive belt tension (Refer to GROUP 00, Maintenance Service – Drive Belts P.00-39.)
  - Fusible link
  - Abnormal noise from the generator while the engine is running
- Turn the ignition switch to the "LOCK" (OFF) position.

**⚠ WARNING**

**Battery posts, terminals and related accessories contain lead and lead compounds. WASH HANDS AFTER HANDLING.**

- Disconnect the negative battery cable.

**⚠ WARNING**

**Never use clips to connect the line. Loose connections (e.g. using clips) will lead to a serious accident because of high current.**

- Disconnect the generator output wire from the generator "B" terminal and connect a DC test ammeter with a range of 0 – 100 A in series between the "B" terminal and the disconnected output wire. (Connect the positive lead of the ammeter to the "B" terminal, and then connect the negative lead of the ammeter to the disconnected output wire.)

*NOTE: A clamp-type ammeter which enables measurements to be taken without disconnecting the generator output wire is recommended.*

TSB Revision



5. Connect a voltmeter with a range of 0 – 20 V between the generator "B" terminal and the ground. (Connect the positive lead of the voltmeter to the "B" terminal, and then connect the negative lead of the voltmeter to the ground.)

**⚠ WARNING**

**Battery posts, terminals and related accessories contain lead and lead compounds. WASH HANDS AFTER HANDLING.**

6. Connect the negative battery cable.
7. Connect a tachometer or scan tool MB991502.
8. Leave the hood open.
9. Check to be sure that the reading on the voltmeter is equal to the battery positive voltage.

*NOTE: If the voltage is 0 V, the cause is probably an open circuit in the wire or fusible link between the generator "B" terminal and the battery positive terminal.*

10. After turning the light switch on and turning on the headlights, start the engine.

*NOTE: Because the current from the battery will soon drop after the engine is started, step 11 should be carried out as quickly as possible in order to obtain the maximum current output value.*

11. Immediately after setting the headlights to high beam and turning the heater blower switch to the high revolution position, increase the engine speed to 2,500 r/min and read the maximum current output value displayed on the ammeter.

**Limit value: 70% of nominal current output**

*NOTE: For the nominal current output, refer to the Generator Specifications.*

*NOTE: The current output value will depend on the electrical load and the temperature of the generator body.*

*NOTE: If the electrical load is small while testing, the specified level of current may not be output even though the generator is normal. In such cases, increase the electrical load by leaving the headlights turned on for some time to discharge the battery or by using the lighting system in another vehicle, and then test again.*

*NOTE: The specified level of current also may not be output if the temperature of the generator body or the ambient temperature is too high. In such cases, cool the generator and then test again.*

12. The reading on the ammeter should be above the limit value. If the reading is below the limit value and the generator output wire is normal, remove the generator from the engine and check the generator.

13. Run the engine at idle speed after the test.

14. Turn the ignition switch to the "LOCK" (OFF) position.

15. Disconnect the tachometer or scan tool MB991502.

**⚠ WARNING**

**Battery posts, terminals and related accessories contain lead and lead compounds. WASH HANDS AFTER HANDLING.**

16. Disconnect the negative battery cable.

17. Disconnect the ammeter and voltmeter and tachometer.

18. Connect the generator output wire to the generator "B" terminal.

**⚠ WARNING**

**Battery posts, terminals and related accessories contain lead and lead compounds. WASH HANDS AFTER HANDLING.**

19. Connect the negative battery cable. Before the test, always be sure to check the following.

## REGULATED VOLTAGE TEST

M1161001100064

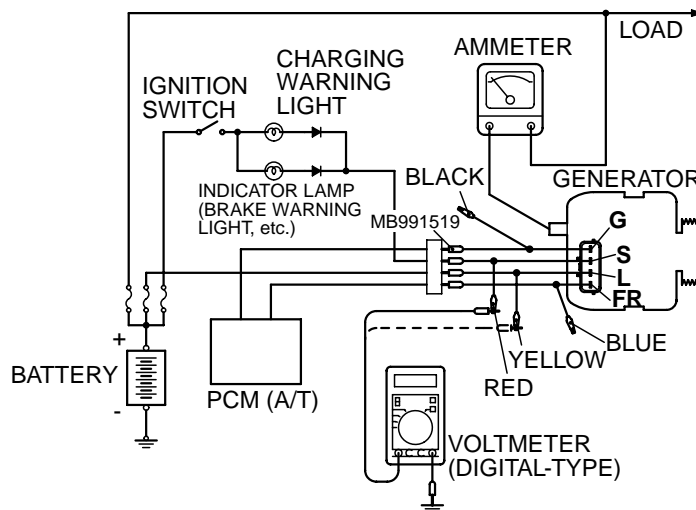

AKX01215 AC

**Required Special Tools:**

- MB991502: Scan Tool (MUT-II)
- MB991519: Generator Harness Connector

This test determines whether the voltage regulator is correctly controlling the generator output voltage.

1. Always be sure to check the following before the test:
  - Generator installation
  - Check to be sure that the battery installed in the vehicle is fully charged. (Refer to GROUP 54A, Battery – On-vehicle Service – Battery Check P.54A-5.)
  - Generator drive belt tension (Refer to GROUP 00, Maintenance Service – Drive Belts P.00-39.)
  - Fusible link
  - Abnormal noise from the generator while the engine is running
2. Turn the ignition switch to the "LOCK" (OFF) position.

**⚠ WARNING**

**Battery posts, terminals and related accessories contain lead and lead compounds. WASH HANDS AFTER HANDLING.**

3. Disconnect the negative battery cable.
4. Use the special tool (Generator harness connector: MB991519) to connect a digital-type voltmeter between the generator "S" terminal and the ground. (Connect the positive lead of the voltmeter to the "S" terminal, and then connect the negative lead of the voltmeter to a secure ground or to the negative battery terminal.)

5. Disconnect the generator output wire from the generator "B" terminal.
6. Connect a DC test ammeter with a range of 0 – 100 A in series between the "B" terminal and the disconnected output wire. (Connect the positive lead of the ammeter to the "B" terminal, and then connect the negative lead of the ammeter to the disconnected output wire.)

**⚠ WARNING**

**Battery posts, terminals and related accessories contain lead and lead compounds. WASH HANDS AFTER HANDLING.**

7. Reconnect the negative battery cable.
8. Connect a tachometer or the scan tool MB991502.
9. Turn the ignition switch to the "ON" position and check that the reading on the voltmeter is equal to the battery positive voltage.
 

*NOTE: If the voltage is 0 V, the cause is probably an open circuit in the wire or fusible link between the generator "S" terminal and the battery positive terminal.*
10. Check to be sure that all lights and accessories are off.
11. Start the engine.
12. Increase the engine speed to 2,500 r/min.
13. Read the value displayed on the voltmeter when the current output by the generator becomes 10 A or less.

14.If the voltage reading conforms to the value in the voltage regulation table, then the voltage regulator is operating normally.

If the voltage is outside the standard value, there is a malfunction of the voltage regulator or the generator (Refer to the following table).

15.After the test, lower the engine speed to the idle speed.

16.Turn the ignition switch to the "LOCK" (OFF) position.

**⚠ WARNING**

**Battery posts, terminals and related accessories contain lead and lead compounds. WASH HANDS AFTER HANDLING.**

17.Disconnect the negative battery cable.

18.Disconnect the ammeter, voltmeter and tachometer.

19.Connect the generator output wire to the generator "B" terminal.

**⚠ WARNING**

**Battery posts, terminals and related accessories contain lead and lead compounds. WASH HANDS AFTER HANDLING.**

20.Connect the negative battery cable.

**VOLTAGE REGULATION TABLE**

INSPECTION TERMINAL	VOLTAGE REGULATOR AMBI- ENT TEMPERATURE [°C(°F)]	STANDARD VALUE (V)
Terminal "S"	-20 (-4)	14.2 – 15.4
	20 (68)	13.9 – 14.9
	60 (140)	13.4 – 14.5
	80 (176)	13.1 – 14.5

**WAVE PATTERN CHECK USING AN  
OSCILLOSCOPE**

M1161001200049

**MEASUREMENT METHOD**

Connect the oscilloscope probe to the generator "B" terminal.

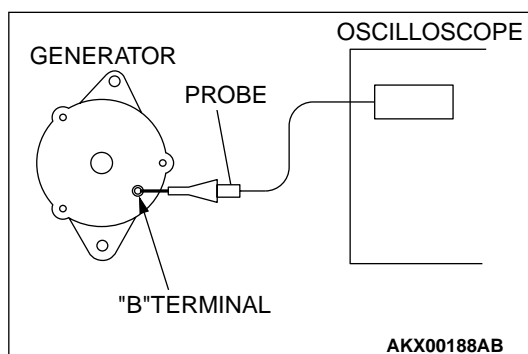

**STANDARD WAVEFORM**

Observation Conditions	
FUNCTION	SPECIAL PATTERNS
Pattern height	Variable

Observation Conditions	
FUNCTION	SPECIAL PATTERNS
Variable knob	Adjust while viewing the wave pattern
Pattern selector	Raster
Engine revolutions	Curb idle speed

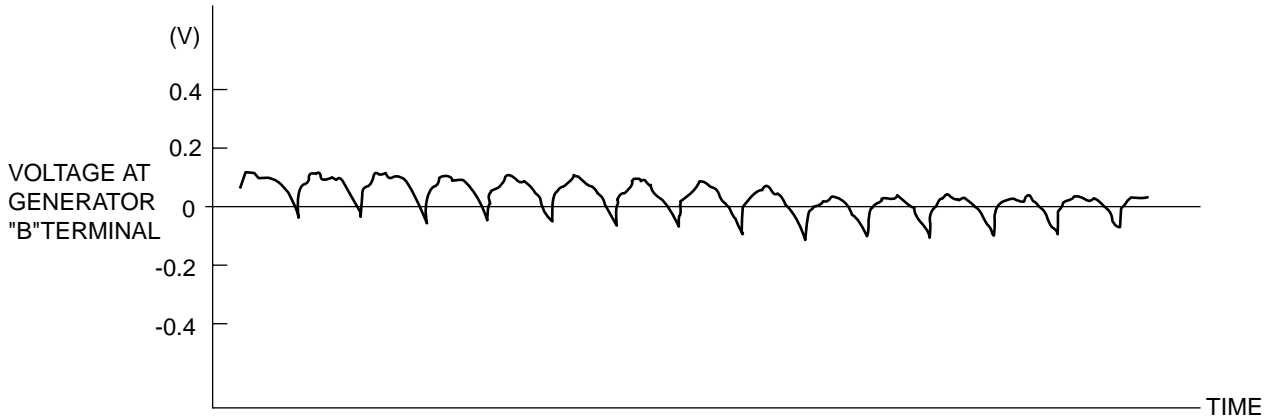

AKX00189 AB

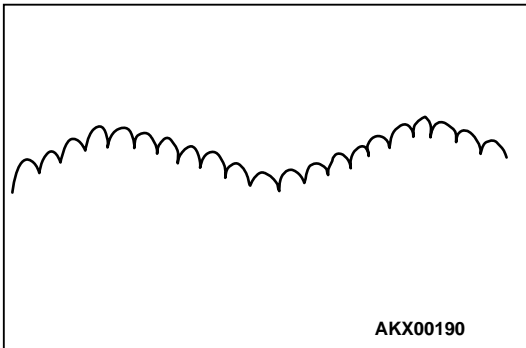





*NOTE: The voltage waveform of the generator "B" terminal can undulate as shown at left. This waveform is produced when the regulator operates according to fluctuations in the generator load (current), and is normal for the generator. If the ripple height is abnormally high (approximately 2 V or more during idling), the wires between the generator B terminal and the battery have broken due to fuse blowing, etc. The generator is usually operating properly.*

**ABNORMAL WAVEFORMS EXAMPLES**

*NOTE: The size of the waveform patterns can differ greatly, depending on the adjustment of the variable knob on the oscilloscope.*

*NOTE: Identification of abnormal waveforms is easier when there is a large output current (regulator is not operating). (Waveforms can be observed when the headlights are illuminated.)*

*NOTE: Check the conditions of the charging indicator light (illuminated/not illuminated) also, and carry out a total check.*

ABNORMAL WAVEFORMS	PROBABLE CAUSE
<p>Example1</p>  <p style="text-align: right;">AKX00191</p>	<p>Open circuit in diode</p>
<p>Example2</p>  <p style="text-align: right;">AKX00192</p>	<p>Short-circuit in diode</p>
<p>Example3</p>  <p style="text-align: right;">AKX00193</p>	<p>Open circuit in stator coil</p>
<p>Example4</p>  <p style="text-align: right;">AKX00194</p>	<p>Short-circuit in stator coil</p>
<p>Example5</p>  <p style="text-align: right;">AKX00195</p>	<p>Open circuit in supplementary diode</p>

## GENERATOR ASSEMBLY

### REMOVAL AND INSTALLATION

M1161001400054

<p><b>Pre-removal Operation</b></p> <ul style="list-style-type: none"> <li>• Under Cover Removal</li> <li>• Engine Mount Bracket Removal (Refer to GROUP 32, Engine Mount <a href="#">P.32-5.</a>)</li> </ul>	<p><b>Post-installation Operation</b></p> <ul style="list-style-type: none"> <li>• Engine Mount Bracket Installation (Refer to GROUP 32 <a href="#">P.32-5.</a>)</li> <li>• Drive Belt Tension Adjustment (Refer to GROUP 00, Maintenance Service – Drive Belts <a href="#">P.00-39.</a>)</li> <li>• Under Cover Installation</li> </ul>
---	--

TSB Revision

<2.4L ENGINE>

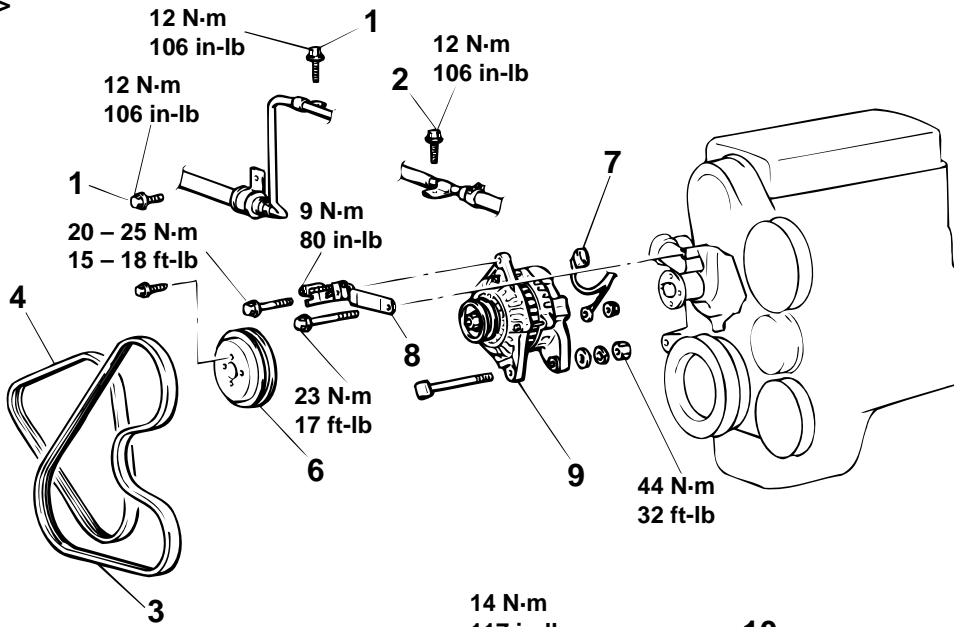

<3.0L ENGINE>

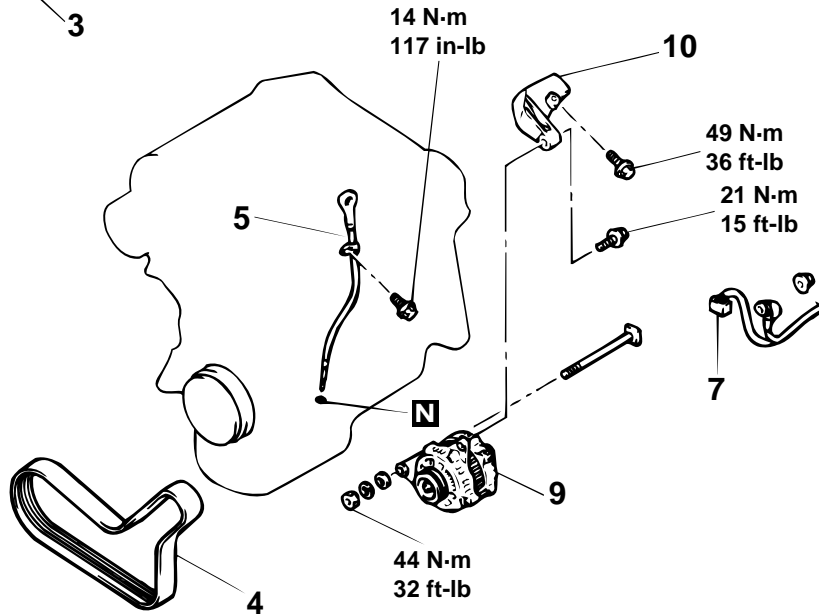

AC000285AC

**REMOVAL STEPS**

1. OIL PRESSURE HOSE AND TUBE ASSEMBLY CLAMP BOLTS <2.4L ENGINE>
2. OIL RETURN TUBE ASSEMBLY CLAMP BOLT <2.4L ENGINE>
3. DRIVE BELT (POWER STEERING, A/C) <2.4L ENGINE>
4. DRIVE BELT (GENERATOR)
5. OIL LEVEL GAUGE UNIT

**REMOVAL STEPS (Continued)**

6. WATER PUMP PULLEY <2.4L ENGINE>
7. GENERATOR CONNECTOR
8. GENERATOR BRACE <2.4L ENGINE>
9. GENERATOR
10. GENERATOR BRACE <3.0L ENGINE>

<<A>>

**REMOVAL SERVICE POINT**

**<<A>> DRIVE BELT (POWER STEERING, A/C) REMOVAL**

1. Loosen nut "A" for holding the tension pulley.
2. Loosen bolt "B" for adjustments.
3. Remove the drive belt.

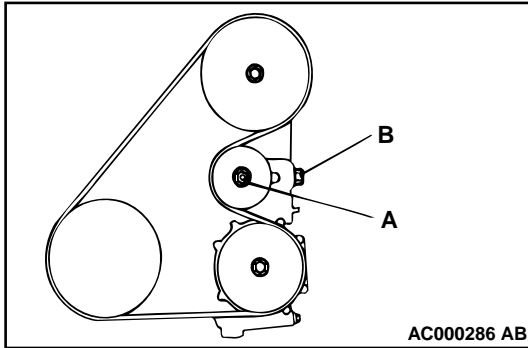

DISASSEMBLY AND ASSEMBLY

M1161001600047

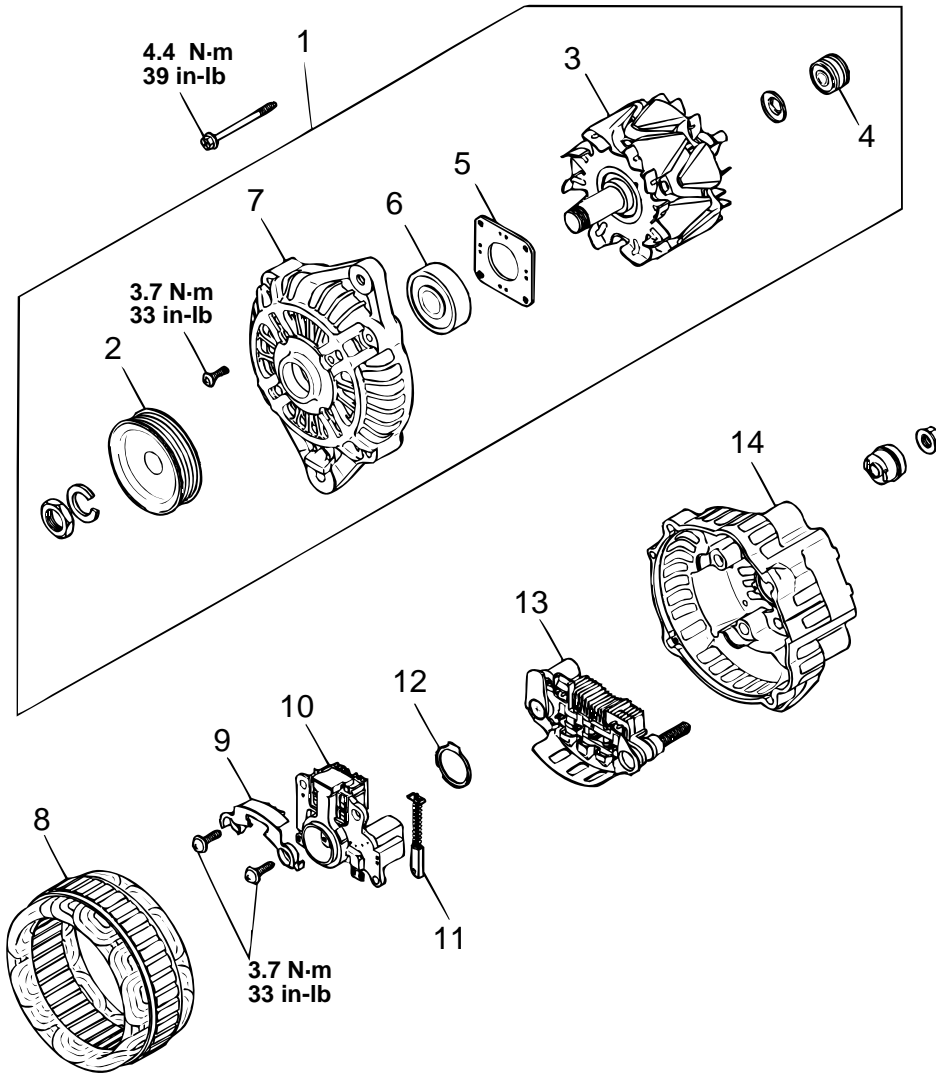

AKX00354 AC

- <<A>>  
 <<B>>  
 >>B<<
- DISASSEMBLY STEPS**
1. FRONT BRACKET ASSEMBLY
  2. GENERATOR PULLEY
  3. ROTOR ASSEMBLY
  4. REAR BEARING
  5. BEARING RETAINER
  6. FRONT BEARING
  7. FRONT BRACKET

- <<C>>  
 >>A<<
- DISASSEMBLY STEPS (Continued)**
8. STATOR
  9. PLATE
  10. REGULATOR ASSEMBLY
  11. BRUSH
  12. SLINGER
  13. RECTIFIER
  14. REAR BRACKET

TSB Revision



## DISASSEMBLY SERVICE POINTS

### <<A>> FRONT BRACKET ASSEMBLY REMOVAL

**⚠ CAUTION**

Do not insert a screwdriver too deep. The stator coil will be damaged.

Insert a flat-tipped screwdriver between the front bracket assembly and the stator core, and pry it downward to separate the stator and front bracket assembly.

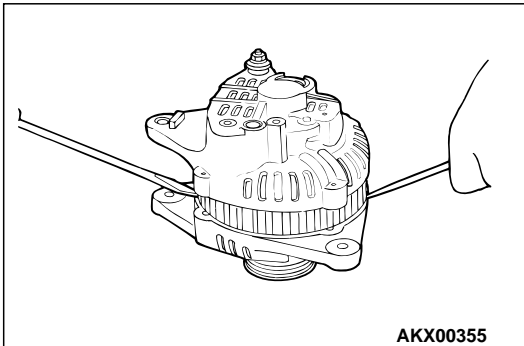

### <<B>> GENERATOR PULLEY REMOVAL

**⚠ CAUTION**

Make sure not to damage the rotor.

Set the pulley upward, clamp the rotor in a vise, and remove the pulley.

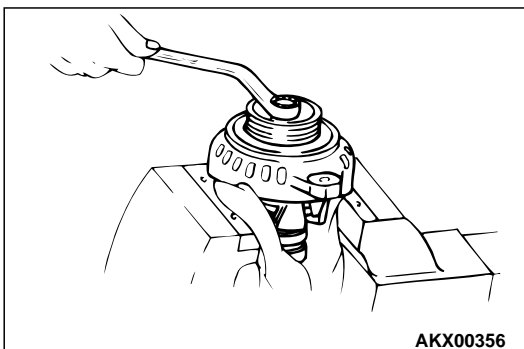

### <<C>> STATOR REMOVAL

**⚠ CAUTION**

- Check that the heat from the soldering iron is not transmitted to the diode for a long time.
- Use care that no undue force is exerted to leads of diodes.

1. Use a soldering iron (180 to 250 W) to unsolder the stator. This work should complete within approximately four seconds to prevent heat from transferring to the diode.
2. When removing the rectifier from the regulator assembly, unsolder the points soldered on the rectifier.

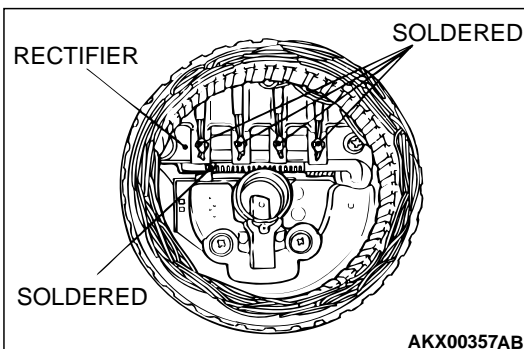

**ASSEMBLY SERVICE POINTS**

**>>A<< REGULATOR ASSEMBLY INSTALLATION**

After installing the regulator assembly, insert a wire through the hole provided on the rear bracket while pressing down on the brush, and secure the brush.

*NOTE: By inserting a wire, the brush will be secured in place, and the installation of the rotor will be easier.*

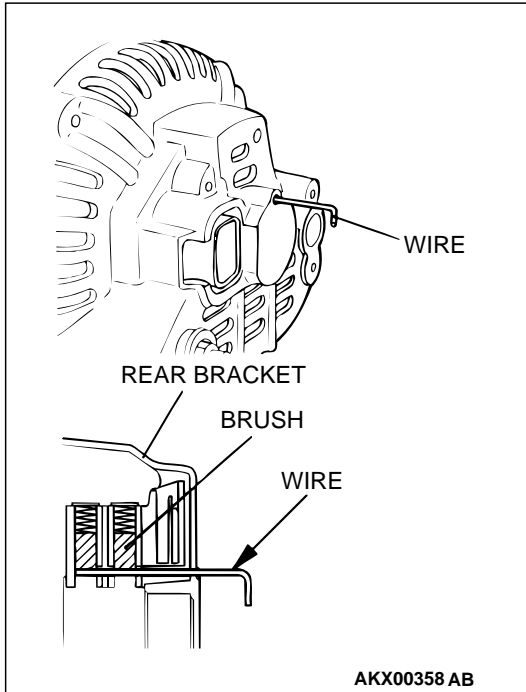

**>>B<< ROTOR ASSEMBLY INSTALLATION**

After installing the rotor, remove the wire used to secure the brush.

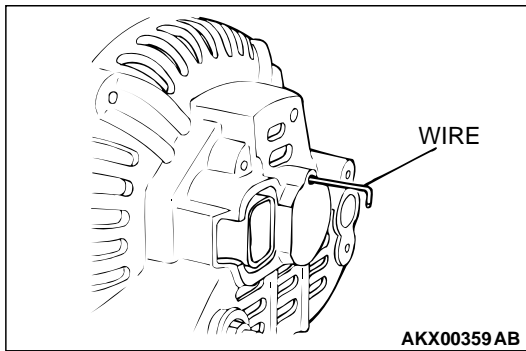

**INSPECTION**

M1161001700022

**ROTOR CHECK**

1. Check the continuity between the slip rings of the field coil. If the resistance value is not within the standard value, replace the rotor.

**Standard value: approximately 2 – 5 Ω**

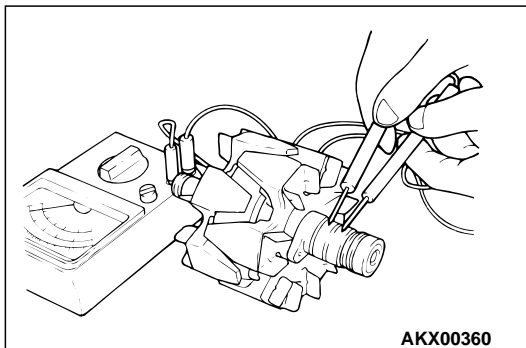

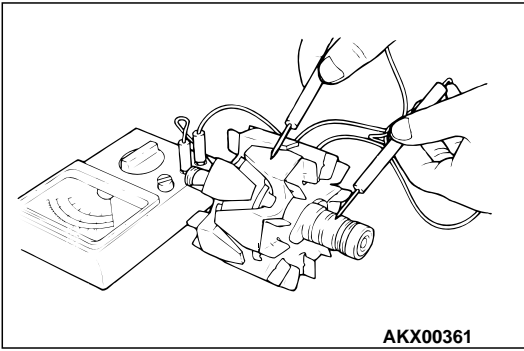

2. Check the continuity between the slip ring and the core. If there is continuity, replace the rotor.

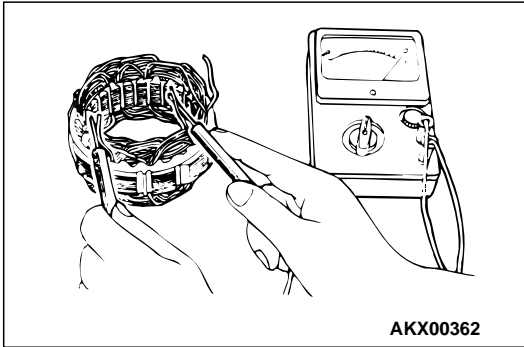

#### STATOR CHECK

1. Check the continuity between the coil lead. If there is no continuity, replace the stator.

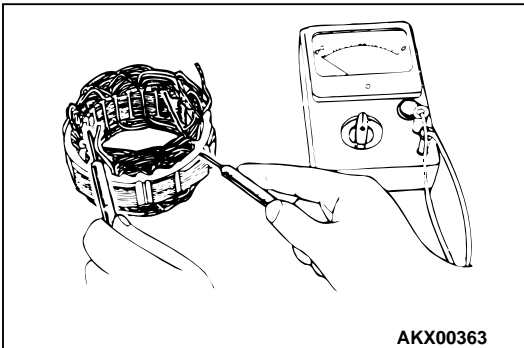

2. Check the continuity between the coil and the core. If there is continuity, replace the stator.

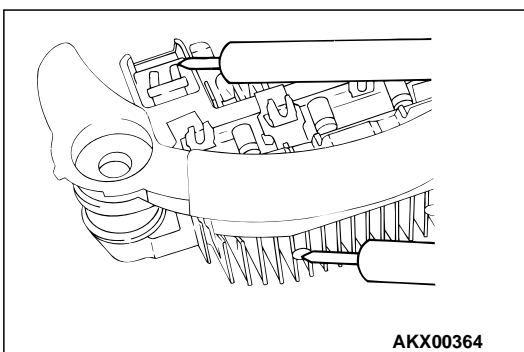

#### RECTIFIER CHECK

1. A positive rectifier test checks the continuity between the positive rectifier and the stator coil lead connection terminal with a tester. If there is continuity at both terminals, the diode is shorted, so replace the rectifier.

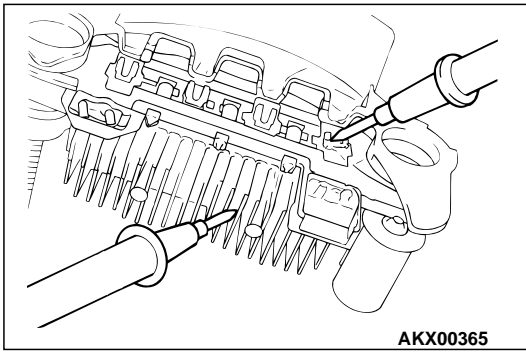

2. A negative rectifier test checks the continuity between the negative rectifier and the stator coil lead connection terminal with a tester. If there is continuity in both terminals, the diode is grounded, so replace the rectifier.

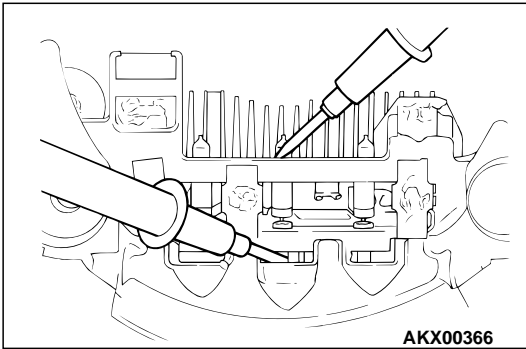

3. A diode trio test checks the continuity of the three diodes by connecting an ohmmeter to both ends of each diode. If there is continuity in both directions, or if there is no continuity, the diode is damaged, so replace the rectifier.

**BRUSH CHECK**

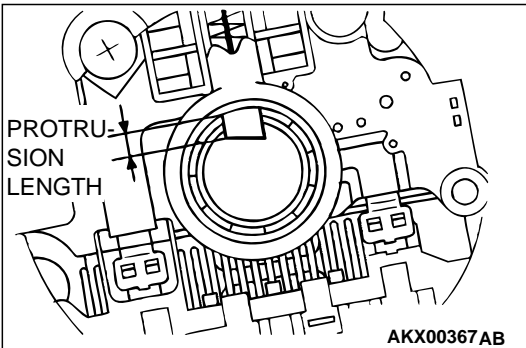

1. Replace the brush if the brush protrusion length shown in the illustration is below the minimum limit value.

**Minimum limit: 2 mm (0.08 inch)**

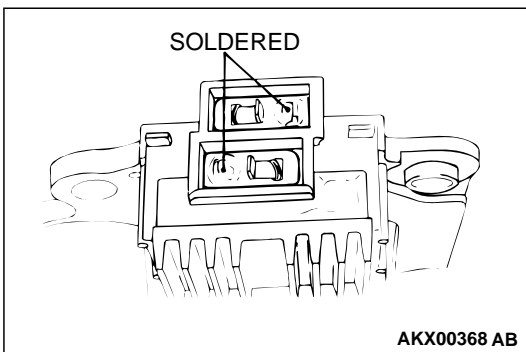

2. The brush can be removed by unsoldering the brush lead wire.  
3. When installing a new brush, push the brush in the brush holder as shown in the illustration, and solder the lead wire.

**STARTING SYSTEM**

**GENERAL DESCRIPTION**

If the ignition switch is turned to the "START" position, current flows in the coil provided inside magnetic switch, attracting the plunger. When the

plunger is attracted, the lever connected to the plunger is actuated to engage the starter clutch.

M1162000100064

TSB Revision

On the other hand, attracting the plunger will turn on the magnetic switch, allowing the B terminal and M terminal to conduct. Thus, current flows to engage the starter motor.

When the ignition switch is returned to the "ON" position after starting the engine, the starter clutch is disengaged from the ring gear. An overrunning clutch is provided between the pinion and the armature shaft, to prevent damage to the starter.

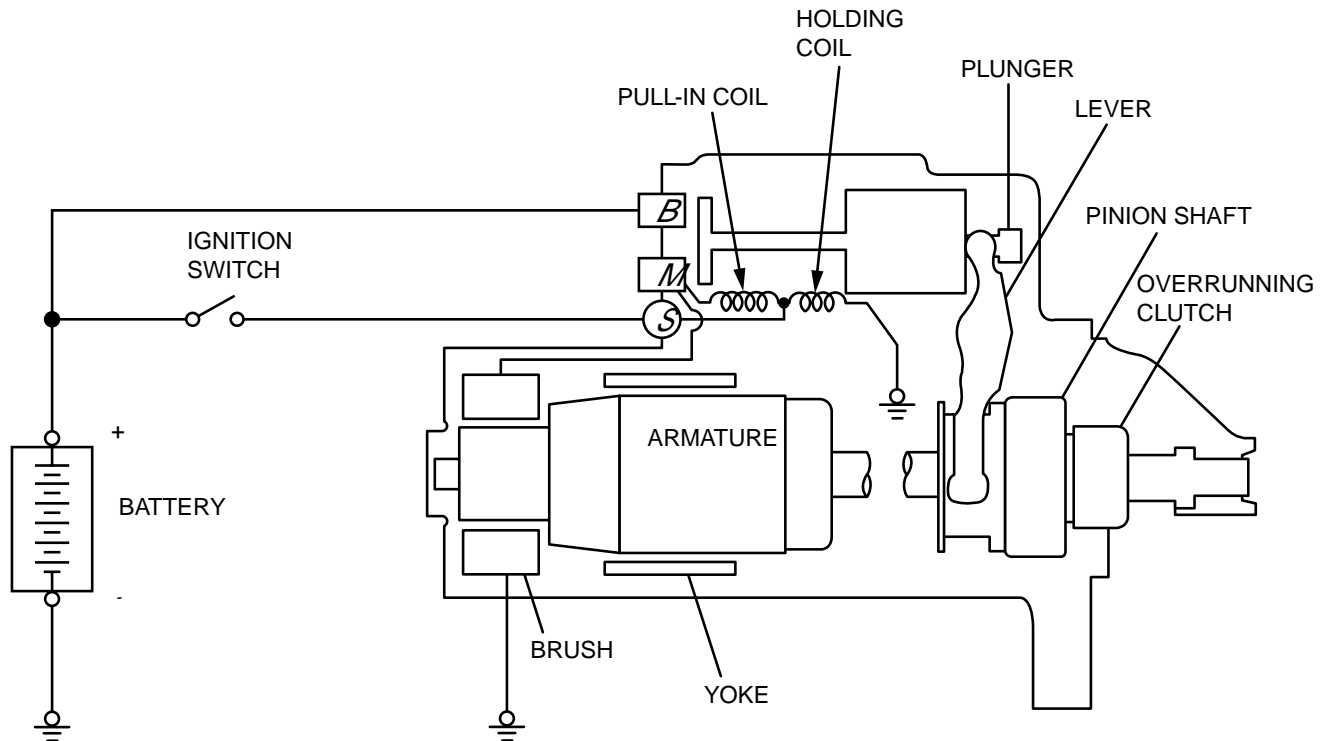

AKX00196 AB

## OPERATION

- When the ignition switch is switched to the "ST" position while the selector lever is at the "P" or "N" position, the contact (magnetic switch) of the starter is switched ON and the starter motor is activated.

## DIAGNOSIS

### TROUBLESHOOTING HINTS

The starter motor does not operate at all.

- Check the starter (coil).
- Check for poor contact at the battery terminals and starter.

M1162000700066

TSB Revision

- Check the park/neutral position switch.
- Check the clutch pedal position switch.
- Check the theft-alarm starter relay.

The starter motor doesn't stop

- Check the starter (magnetic switch).

## TROUBLESHOOTING GUIDE

The starting system troubleshooting guide is shown in the following chart.

---

### STEP 1.

**Q: Is the battery in good condition? (Refer to GROUP 54A, Battery – On-vehicle Service - Battery Check P.54A-5).**

**OK :** Go to Step 2.

**NG :** Charge or replace the battery.

---

### STEP 2.

- Disconnect the starter motor S (solenoid) terminal connector.
- Using a jumper wire, apply battery positive voltage to the starter motor S (solenoid) terminal.
- Check the engine condition.  
OK: Turns normally

**Q: Does the starter motor operate normally?**

- OK :**
- Check the ignition switch (Refer to GROUP 54A, Ignition Switch - Ignition Switch P.54A-27.)
  - Check the starter relay.
  - Check the park/neutral position switch. (Refer to GROUP 23A, On-vehicle Service - Essential Service P.23A-278.)
  - Check the line between the battery and starter motor S (solenoid) terminal.

**NG :** Go to Step 3.

---

### STEP 3.

- Check the cable between starter B (battery) terminal and battery positive terminal for connection and continuity.

**Q: Is the starter cable in good condition?**

**OK :** Go to Step 4.

**NG :** Repair or replace the cable.

---

### STEP 4.

- Check the connection and the continuity of the cable between the starter motor body and the negative battery terminal.

**Q: Is the ground line in good condition?**

**OK :** Go to Step 5.

**NG :** Repair or replace the cable.

STEP 5.

Q: Is the starter motor in good condition? (Refer to Starting system – Starter motor - Inspection P.16-24.)

OK : Excessive rotational resistance of the engine.

NG : Replace the starter motor.

**STARTER MOTOR ASSEMBLY  
REMOVAL AND INSTALLATION**

M1162001000060

**Pre-removal and Post-installation Operation**

- Air Cleaner Removal and Installation (Refer to GROUP 15, Air Cleaner P.15-4.)

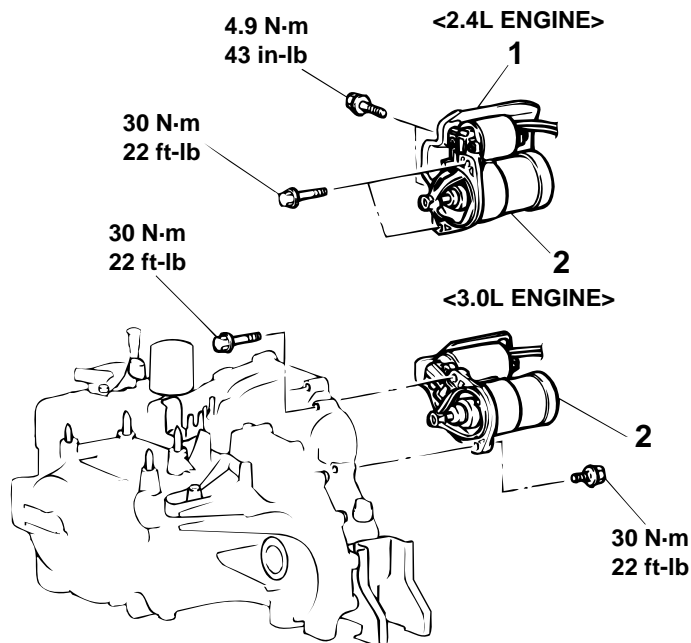

AC000287AC

**REMOVAL STEPS**

1. STARTER COVER <2.4L ENGINE>
2. STARTER MOTOR

INSPECTION

PINION GAP ADJUSTMENT

1. Disconnect the field coil wire from the M-terminal of the magnetic switch.
2. Connect a 12-volt battery between the S-terminal and M-terminal.

**CAUTION**

**This test must be performed quickly (in less than 10 seconds) to prevent the coil from burning.**

3. Set the switch to "ON," and the pinion will move out.

4. Check the pinion-to-stopper clearance (pinion gap) with a feeler gauge.

**Standard value: 0.5 – 2.0 mm (0.02 – 0.07 inch)**

5. If the pinion gap is out of specification, adjust by adding or removing gasket(s) between the magnetic switch and front bracket.

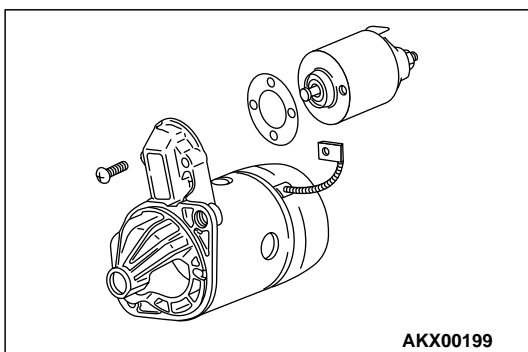
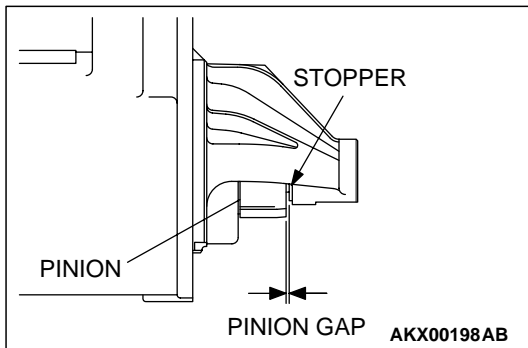
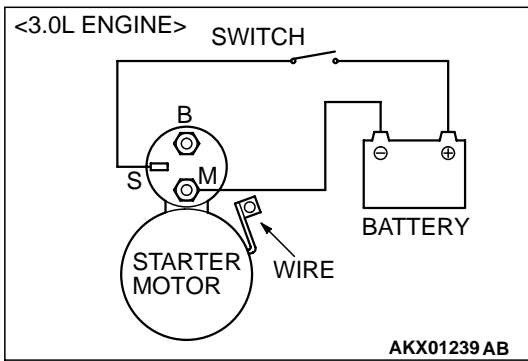
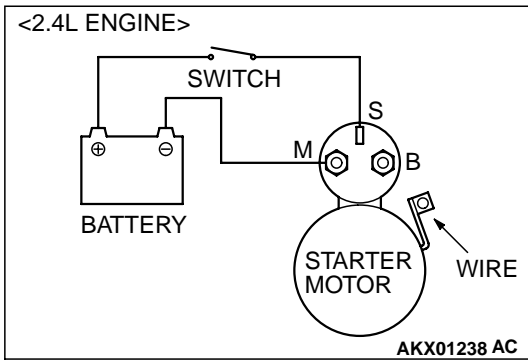



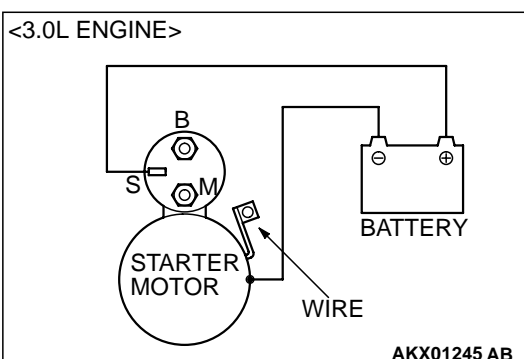
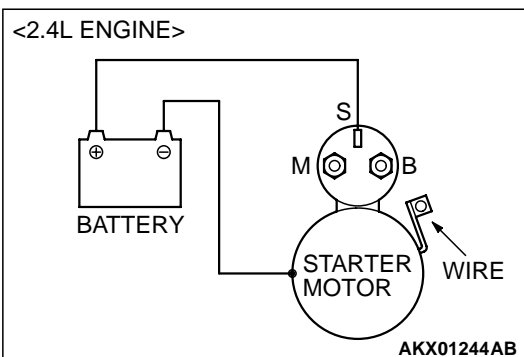
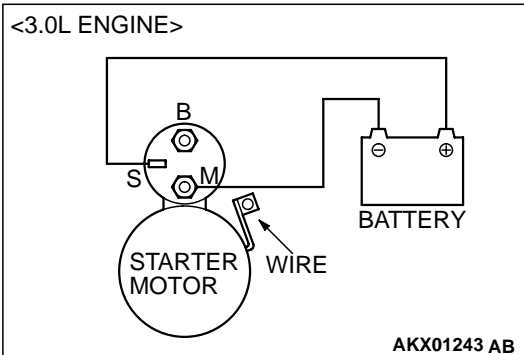
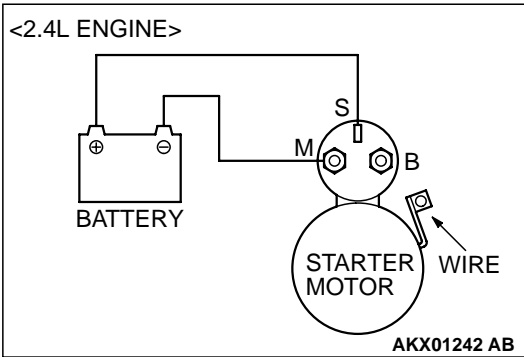

### MAGNETIC SWITCH PULL-IN TEST

1. Disconnect the field coil wire from the M-terminal of the magnetic switch.

#### **CAUTION**

**This test must be performed quickly (in less than 10 seconds) to prevent the coil from burning.**

2. Connect a 12-volt battery between the S-terminal and M-terminal.
3. If the pinion moves out, the pull-in coil is good. If it doesn't, replace the magnetic switch.

### MAGNETIC SWITCH HOLD-IN TEST

1. Disconnect the field coil wire from the M-terminal of the magnetic switch.

#### **CAUTION**

**This test must be performed quickly (in less than 10 seconds) to prevent the coil from burning.**

2. Connect a 12-volt battery between the S-terminal and body.
3. Manually pull out the pinion as far as the pinion stopper position.
4. If the pinion remains out, everything is operating properly. If the pinion moves in, the hold-in circuit is open. Replace the magnetic switch.

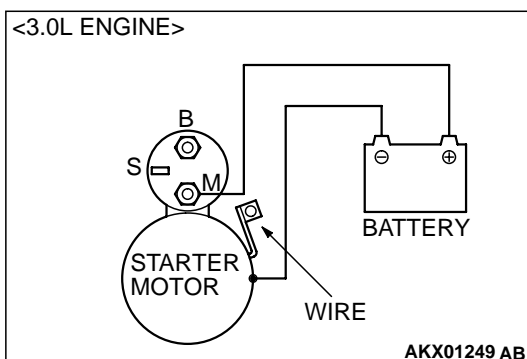
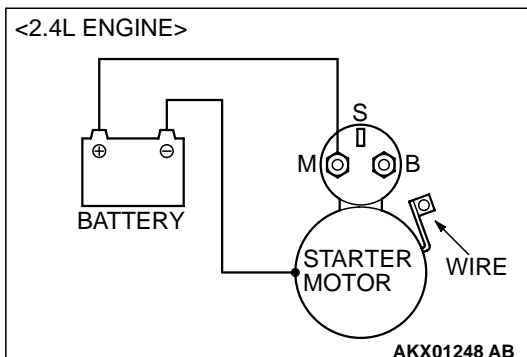
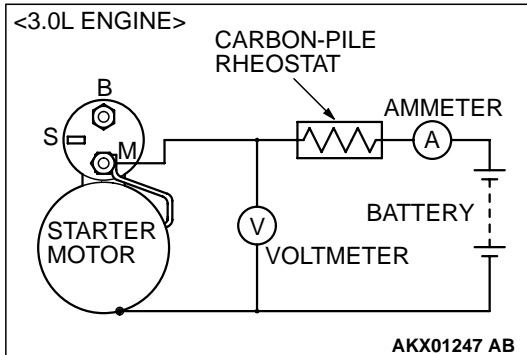
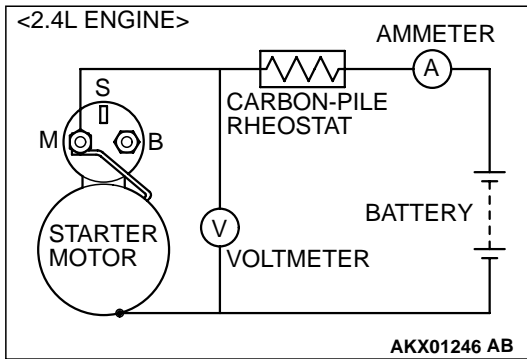

**FREE RUNNING TEST**

1. Place the starter motor in a vise equipped with soft jaws and connect a fully-charged 12-volt battery to the starter motor as follows:
2. Connect a test ammeter (100-ampere scale) and carbon pile rheostat in series between the positive battery terminal and starter motor terminal.
3. Connect a voltmeter (15-volt scale) across the starter motor.
4. Rotate carbon pile to full-resistance position.
5. Connect the battery cable from the negative battery terminal to the starter motor body.
6. Adjust the rheostat until the battery positive voltage shown by the voltmeter is 11 V.
7. Confirm that the maximum amperage is within the specifications and that the starter motor turns smoothly and freely.

**Current: maximum 90 Amps**

**MAGNETIC SWITCH RETURN TEST**

1. Disconnect the field coil wire from the M-terminal of the magnetic switch.

**CAUTION**

**This test must be performed quickly (in less than 10 seconds) to prevent the coil from burning.**

2. Connect a 12-volt battery between the M-terminal and body.

**WARNING**

**Be careful not to get your fingers caught when pulling out the pinion.**

3. Pull the pinion out and release. If the pinion quickly returns to its original position, everything is operating properly. If it doesn't, replace the magnetic switch.

DISASSEMBLY AND ASSEMBLY

M1162001200053

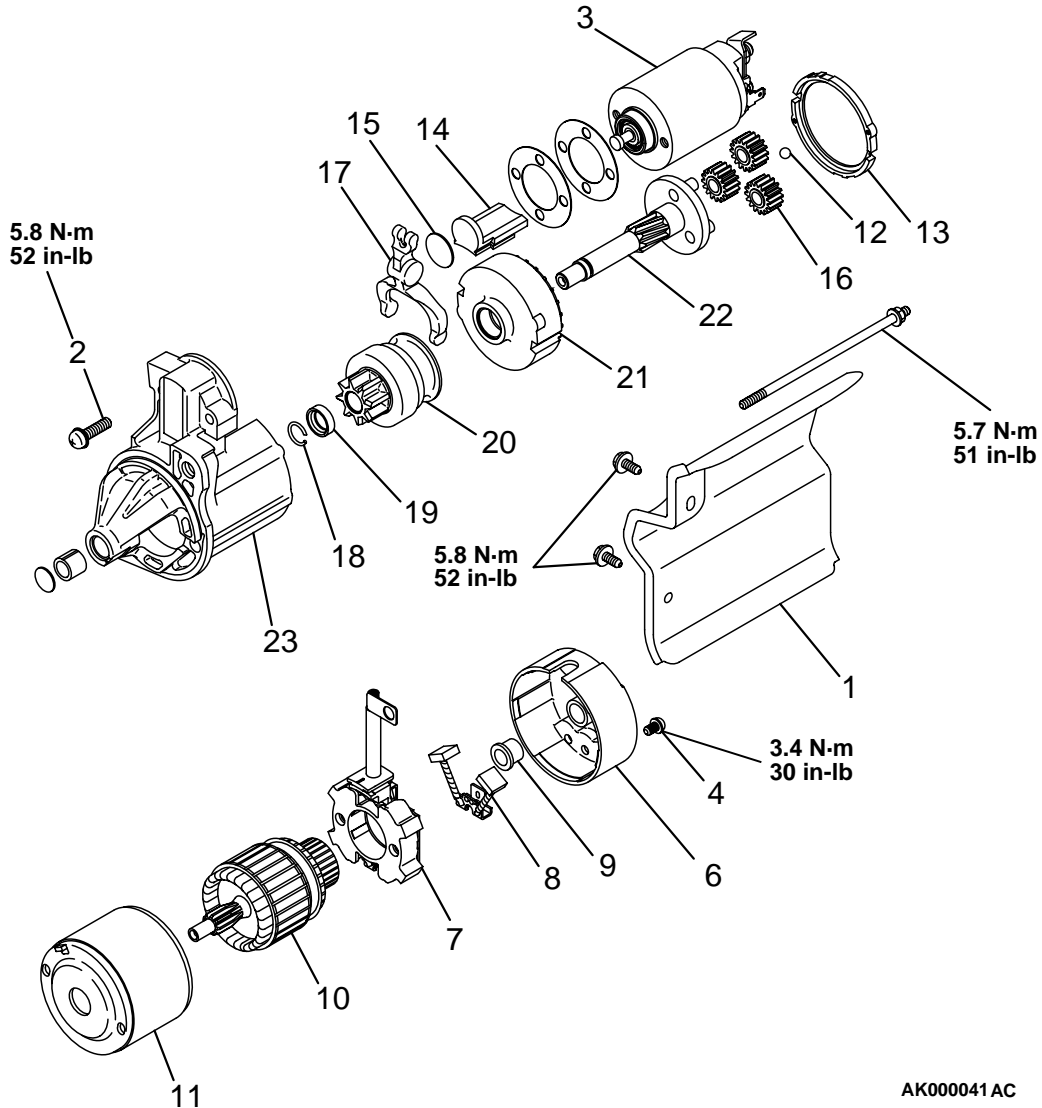

AK000041AC

**DISASSEMBLY STEPS**

1. COVER
2. SCREW
3. MAGNETIC SWITCH
4. SCREW
5. SCREW
6. REAR BRACKET
7. BRUSH HOLDER
8. BRUSH
9. REAR BEARING
10. ARMATURE
11. YOKE ASSEMBLY
12. BALL

<<A>>

<<A>>

**DISASSEMBLY STEPS (Continued)**

13. PACKING A
  14. PACKING B
  15. PLATE
  16. PLANETARY GEAR
  17. LEVER
  18. SNAP RING
  19. STOP RING
  20. OVERRUNNING CLUTCH
  21. INTERNAL GEAR
  22. PLANETARY GEAR HOLDER
  23. FRONT BRACKET
- <<B>> >>A<<  
<<B>> >>A<<

TSB Revision

**DISASSEMBLY SERVICE POINTS**

**<<A>> ARMATURE AND BALL REMOVAL**

**⚠ CAUTION**

When removing the armature, take care not to lose the ball (which is used as a bearing) in the armature end.

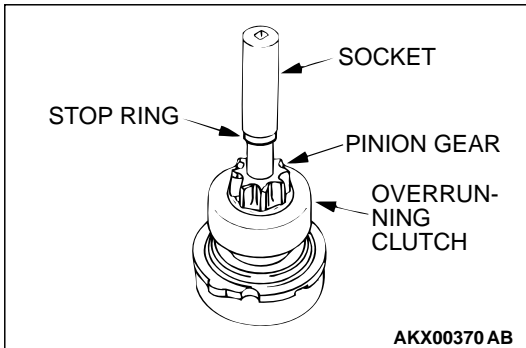

**<<B>> SNAP RING AND STOP RING REMOVAL**

1. Press a long socket wrench of appropriate size to the stop ring. Then tap the socket wrench to remove the stop ring to the pinion gear side.
2. After removing the snap ring (by using snap-ring pliers), remove the stop ring and the overrunning clutch.

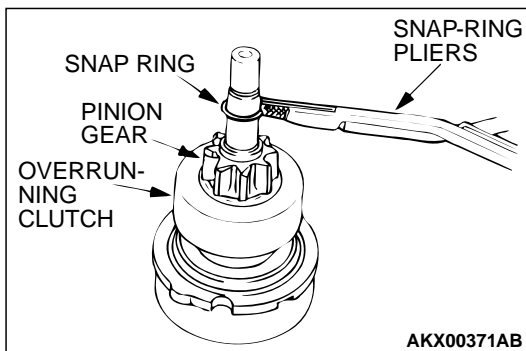

**STARTER MOTOR PART CLEANING**

1. Do not immerse parts in cleaning solvent. Immersing the yoke and field coil assembly and/or armature will damage insulation. Wipe these parts with a shop towel only.
2. Do not immerse the drive unit in cleaning solvent. Overrunning clutch is pre-lubricated at the factory and solvent will wash lubrication from the clutch.
3. The drive unit may be cleaned with a brush moistened with cleaning solvent and wiped dry with a shop towel.

**ASSEMBLY SERVICE POINT**

**>>A<< STOP RING AND SNAP RING INSTALLATION**

1. Using a suitable pulling tool, pull the overrunning clutch stop ring over the snap ring.

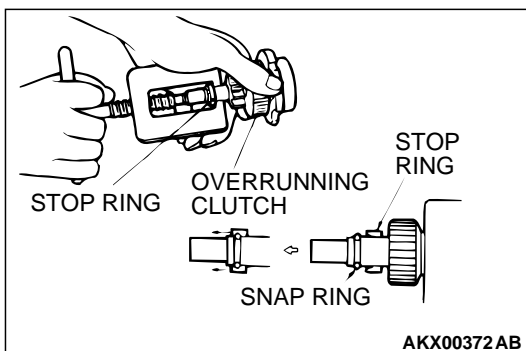

## INSPECTION

### COMMUTATOR CHECK

1. Place the armature on a pair of V-blocks, and check the deflection by using a dial gauge.

**Standard value: 0.05 mm (0.002 inch)**

**Limit: 0.1 mm (0.004 inch)**

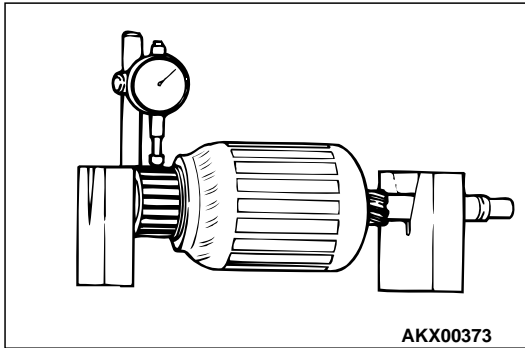

2. Check the outer diameter of the commutator.

**Standard value: 29.4 mm (1.16 inch)**

**Minimum limit: 28.8 mm (1.13 inch)**

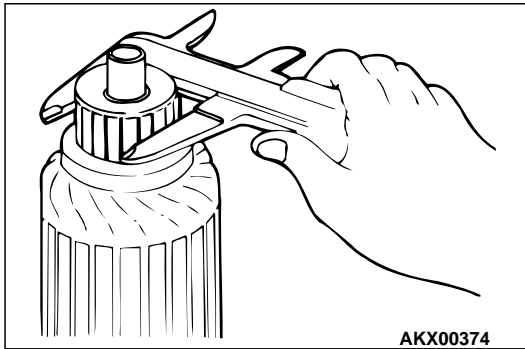

3. Check the depth of the undercut between segments.

**Standard value: 0.5 mm (0.02 inch)**

**Minimum limit: 0.2 mm (0.008 inch)**

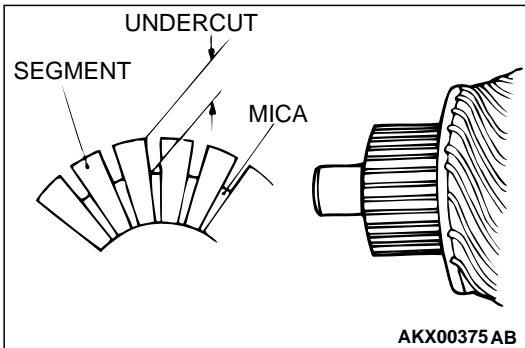

### BRUSH CHECK

1. Brushes that are worn beyond wear limit line, or oil-soaked, should be replaced.
2. When replacing the ground brush, slide the brush from the brush holder by prying the retaining spring back.

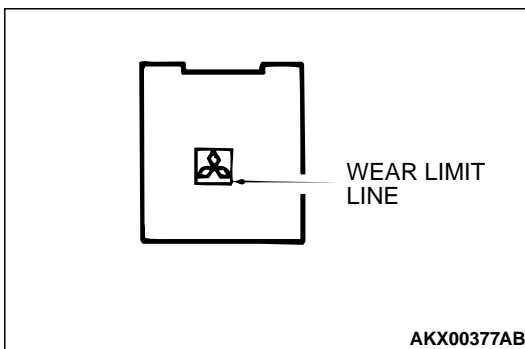

**OVERRUNNING CLUTCH CHECK**

1. While holding the clutch housing, rotate the pinion. The drive pinion should rotate smoothly in one direction, but should not rotate in opposite direction. If the clutch does not function properly, replace the overrunning clutch assembly.
2. Inspect the pinion for wear or burrs. If the pinion is worn or burred, replace the overrunning clutch assembly. If the pinion is damaged, also inspect the ring gear for wear or burrs.

**FRONT AND REAR BRACKET BUSHING CHECK**

Inspect the bushing for wear or burrs. If the bushing is worn or burred, replace the front bracket assembly or rear bracket assembly.

**ARMATURE CHECK**

1. Check that the armature coil is not grounded.
2. Place the armature in a growler.
3. Hold a thin steel blade parallel and just above while rotating the armature slowly in the growler. A shorted armature will cause a blade to vibrate and be attracted to the core. Replace the shorted armature.

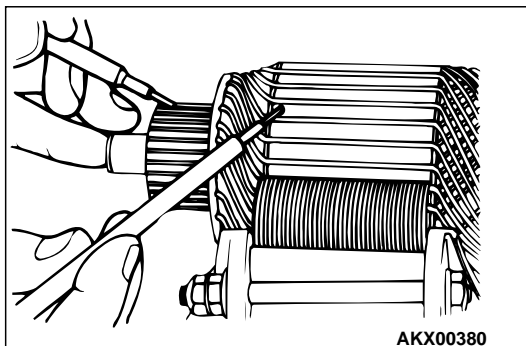
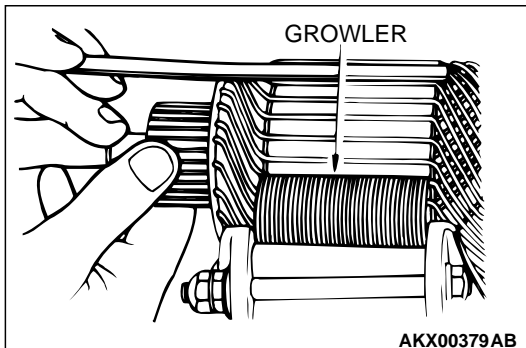

4. Check the insulation between the armature coil cores and the commutator segments. They are normal if there is no continuity.

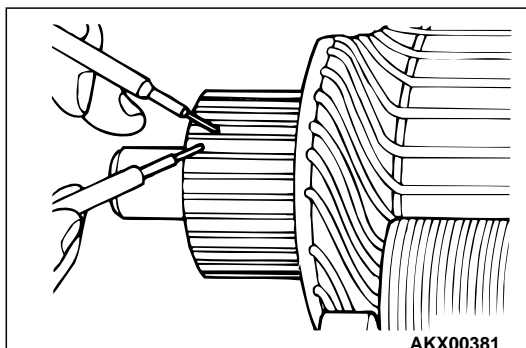

5. Check for continuity between the segments. The condition is normal if there is continuity.

# IGNITION SYSTEM

## GENERAL DESCRIPTION

M1163000100067

### <2.4L Engine>

This system is provided with two ignition coils (A and B) with built-in ignition power transistors for the number 1 and number 4 cylinders, and number 2 and number 3 cylinders respectively.

Interruption of the primary current flowing in the primary side of ignition coil A generates a high voltage in the secondary side of ignition coil A. The high voltage thus generated is applied to the spark plugs of number 1 and number 4 cylinders to generate sparks. At the time that the sparks are generated at both spark plugs, if one cylinder is at the compression stroke, the other cylinder is at the exhaust stroke, so that ignition of the compressed air/fuel mixture occurs only for the cylinder which is at the compression stroke.

In the same way, when the primary current flowing in ignition coil B is interrupted, the high voltage thus generated is applied to the spark plugs of number 2 and number 3 cylinders.

The engine control module controls the two ignition power transistors to turn them alternately ON and OFF. This causes the primary currents in the ignition coils to be alternately interrupted and allowed to flow to fire the cylinders in the order 1 – 3 – 4 – 2.

The engine control module determines which ignition coil should be controlled by means of the signals from the camshaft position sensor which is incorporated in the camshaft and from the crankshaft position sensor which is incorporated in the crankshaft.

It also detects the crankshaft position in order to provide ignition at the most appropriate timing in response to the engine operation conditions. When the engine is cold or operated at high altitudes, the ignition timing is slightly advanced to provide optimum performance.

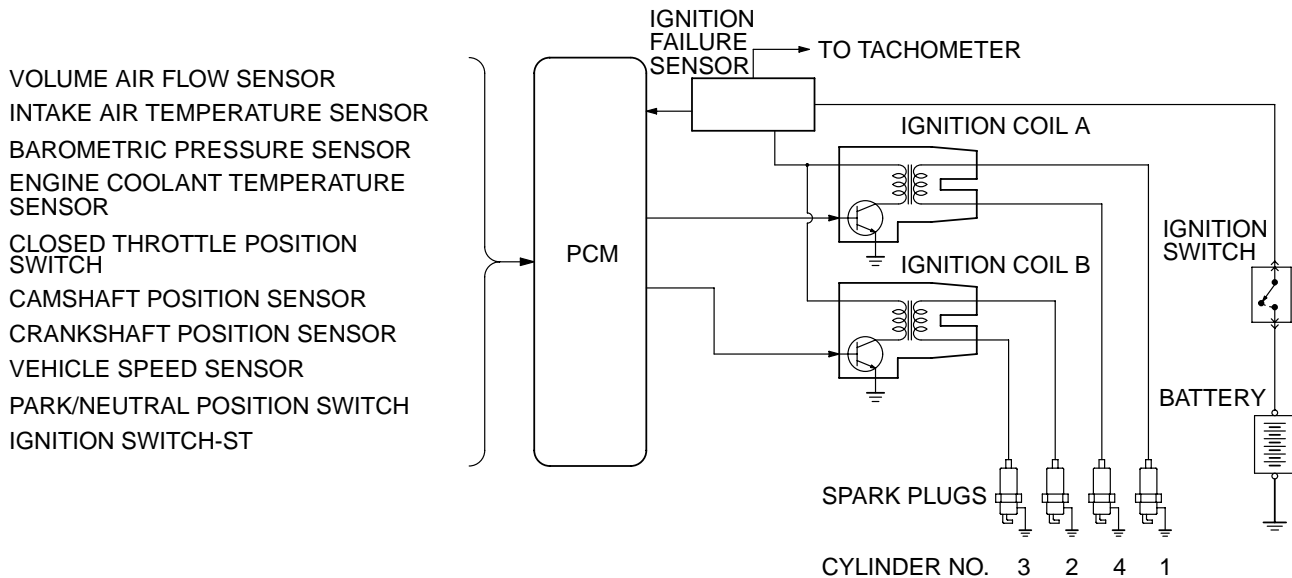

AKX01212 AC

### <3.0L Engine>

Interruption of the primary current flowing in the primary side of the ignition coil generates high voltage in the secondary side of the ignition coil. The high voltage thus generated is directed by the distributor to the applicable spark plug. The engine firing order is 1 – 2 – 3 – 4 – 5 – 6 cylinders.

On application of high voltage, the spark plug generates a spark to ignite the compressed air fuel mixture in the combustion chamber. The engine control module makes and breaks the primary current of the ignition coil to regulate the ignition timing.

TSB Revision

The engine control module detects the crankshaft position by the crankshaft position sensor. This sensor is installed at the front end of the crankshaft to provide ignition at the most appropriate timing for the engine operating condition.

When the engine is cold, the ignition timing is slightly advanced to provide optimum performance to the operating condition.

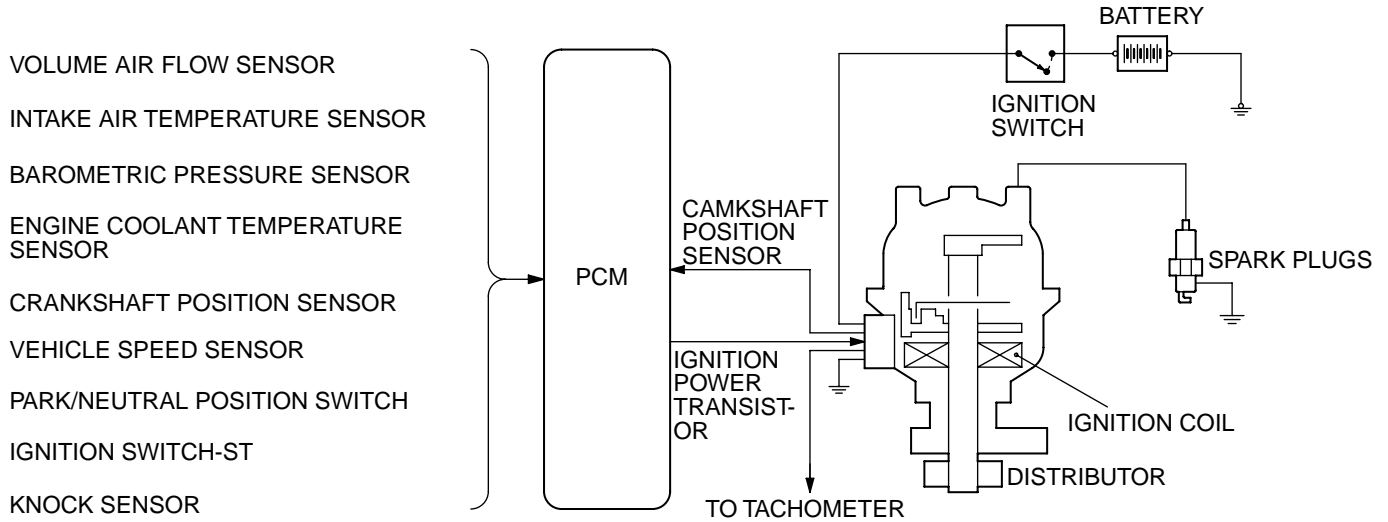

AKX01291AC

**SPECIAL TOOLS**

M1163000600040

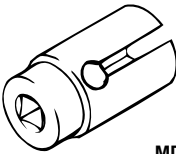
TOOL	TOOL NUMBER AND NAME	SUPERSESSION	APPLICATION
 MB991348	MB991348 Test harness set	Tool not available	Inspection of ignition primary voltage (Ignition power transistor connection)
 MD998773	MD998773 Knock sensor wrench	MD998773-01	Knock sensor removal and installation



## ON-VEHICLE SERVICE

### SPARK PLUG CABLE TEST

M1163000900030

**⚠ WARNING**

***Wear rubber gloves while performing this test.***

1. Disconnect, one at a time, each of the spark plug cables while the engine is idling to check whether the engine's running performance changes or not.
2. If the engine performance does not change, check the resistance of the spark plug cable, and check the spark plug itself.

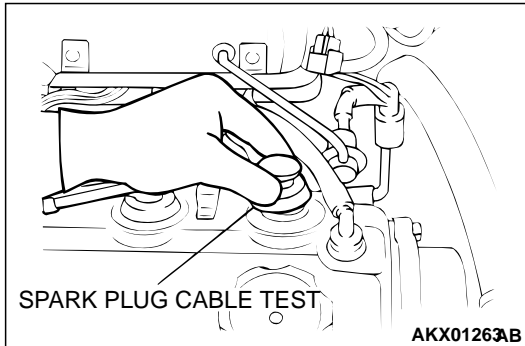

### IGNITION COIL CHECK

M1163001200056

#### <2.4L ENGINE – With built-in ignition power transistor>

Check by the following procedure, and replace the coil if there is a malfunction.

#### SECONDARY COIL RESISTANCE CHECK

Measure the resistance between the high-voltage terminals of the ignition coil.

**Standard value: 8.5 – 11.5 kΩ**

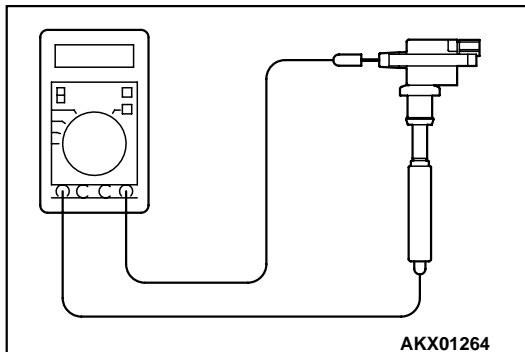

#### PRIMARY COIL AND IGNITION POWER TRANSISTOR CONTINUITY CHECK

*NOTE: An analog-type ohmmeter should be used.*

*NOTE: Connect the negative (-) probe of the ohmmeter to terminal 1.*

**⚠ CAUTION**

**This test must be performed quickly (in less than 10 seconds) to prevent coil from burning and ignition power transistor from breaking.**

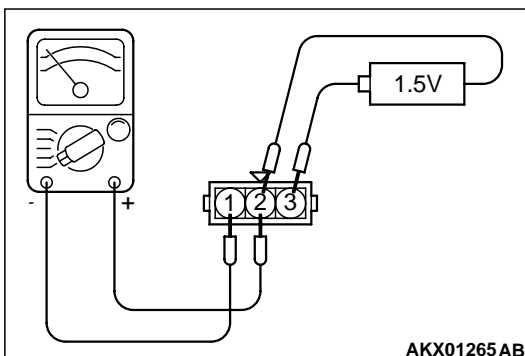

VOLTAGE: 1.5V	BATTERY POWER SUPPLY TERMINAL	SPECIFIED CONDITION
When current is flowing	2 – 3	1 – 2
When current is not flowing	-	-

**IGNITION COIL CHECK**

M1163001200078

**<3.0L ENGINE>**

1. Measurement of the primary coil resistance  
Measure the resistance between connector terminals 1 and 2 of the distributor.

**Standard value: 0.56 – 0.68 Ω**

2. Measurement of the secondary coil resistance  
Measure the resistance between the high-voltage terminal and connector terminal 1.

**Standard value: 9.4 – 12.8 kΩ**

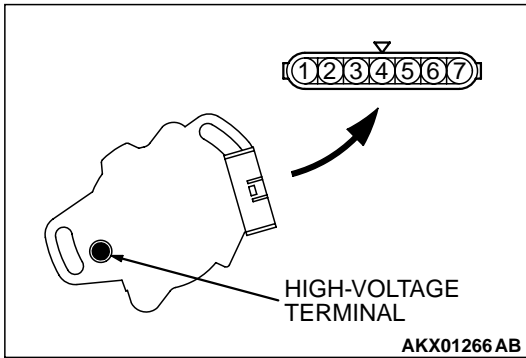

AKX01266 AB

**IGNITION COIL POWER TRANSISTOR CONTINUITY CHECK**

M1163001300042

**<3.0L ENGINE>**

*NOTE: An analog-type ohmmeter should be used.*

*NOTE: Connect the negative (-) probe of the ohmmeter to terminal 2.*

**CAUTION**

**This test must be performed quickly (in less than 10 seconds) to prevent coil from burning and ignition power transistor from breaking.**

Replace the ignition power transistor if there is a malfunction.

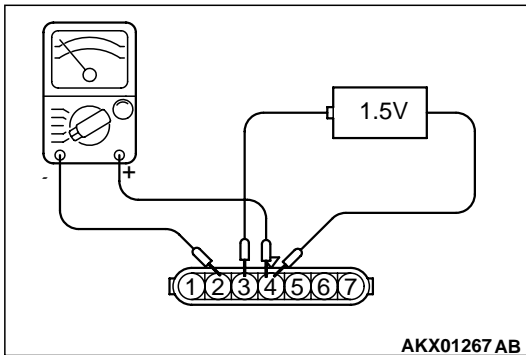

AKX01267 AB

VOLTAGE: 1.5V	BATTERY POWER SUPPLY TERMINAL	SPECIFIED CONDITION
When current is flowing	3 – 4	2 – 3
When current is not flowing	-	-

**IGNITION FAILURE SENSOR CHECK**

M1163003000036

**<2.4L ENGINE>**

*NOTE: An analog-type ohmmeter should be used.*

*Check that the resistance between terminals 3 and 4 is at the standard value.*

**Standard value: 0.1 Ω or less**

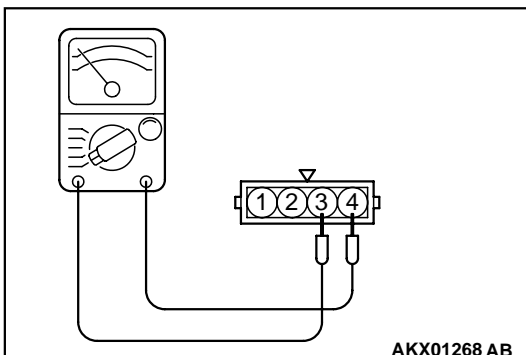

AKX01268 AB

## SPARK PLUG CABLE RESISTANCE CHECK

M1163001400049

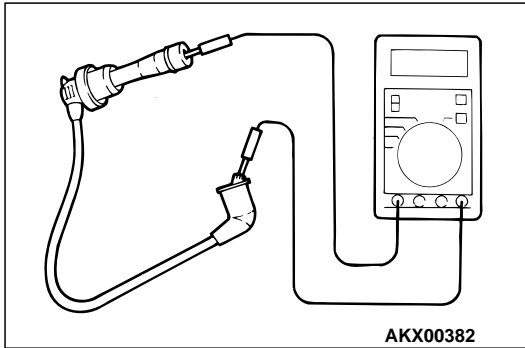

Measure the resistance of the all spark plug leads.

1. Check the cap and coating for cracks.
2. Measure the resistance.

**Limit: 22 kΩ**

## SPARK PLUG TEST

M1163001500079

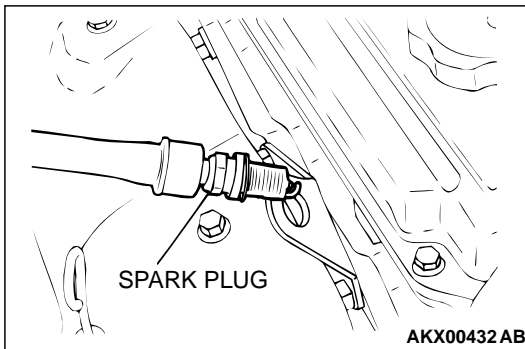

1. Remove the spark plug and connect to the spark plug cable.
2. Ground the spark plug outer electrode (body), and crank the engine.

Check that there is an electrical discharge between the electrodes at this time.

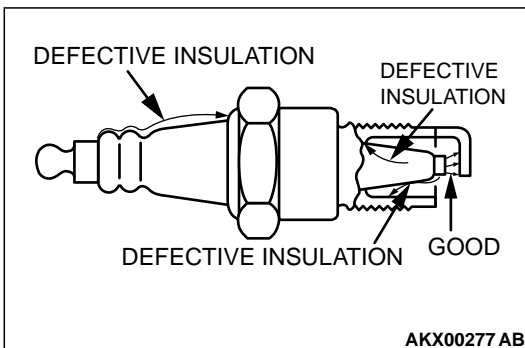

## SPARK PLUG CHECK AND CLEANING

M1163004300029

### <2.4L ENGINE>

1. Check that the plug is not burned, that the insulator plug is not damaged, and that the seizure state is good.
2. If cleaning is required due to carbon deposits, etc., clean using a plug cleaner or wire brush, etc.
3. Check the plug gap using a plug gap gauge, and adjust if not within the standard value.

**Standard value: 1.0 – 1.1 mm (0.039 – 0.043 inch)**

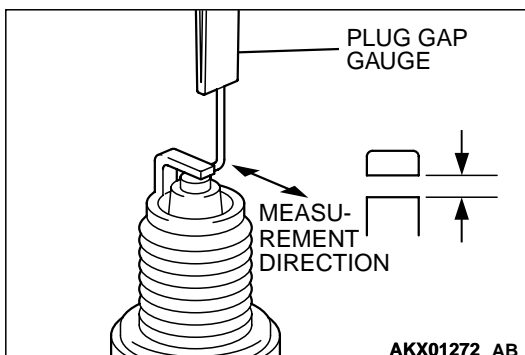

**SPARK PLUG CHECK AND CLEANING**

M1163004300030

**<3.0L ENGINE>****⚠ CAUTION**

- Do not attempt to adjust the gap of the platinum plug.
- Cleaning of the platinum plug may result in damage to the platinum tips. Therefore, if carbon deposits must be removed, use a plug cleaner and complete cleaning within 20 seconds to protect the electrode. Do not use a wire brush.

Check the plug gap and replace if the limit is exceeded.

**Standard value: 1.0 – 1.1 mm (0.039 – 0.043 inch)**

**Limit: 1.3 mm (0.051 inch)**

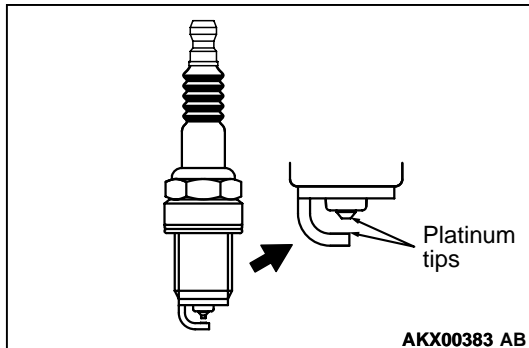
**CAMSHAFT POSITION SENSOR CHECK**

M1163004400037

**<2.4L ENGINE>**

Refer to GROUP 13A, Multiport fuel injection (MFI) diagnosis – Diagnostic trouble code procedures – Camshaft position sensor circuit malfunction (P.13A-179).

**CRANK ANGLE SENSOR CHECK**

M1163004500034

**<2.4L ENGINE>**

Refer to GROUP 13A, Multiport fuel injection (MFI) diagnosis – Diagnostic trouble code procedures – Crankshaft position sensor circuit malfunction (P.13A-170).

**CRANK ANGLE SENSOR CHECK**

M1163004500045

**<3.0L ENGINE>**

Refer to GROUP 13B, Multiport fuel injection (MFI) diagnosis – Diagnostic trouble code procedures – Crankshaft position sensor circuit malfunction (P.13B-240).

**IGNITION SECONDARY VOLTAGE WAVE PATTERN CHECK USING A OSCILLOSCOPE**

M1163001700073

**<2.4L ENGINE>****MEASUREMENT METHOD**

1. Clamp the spark plug cable (Number 1 or 3) with the secondary pickup.

*NOTE: Because of the two-cylinder simultaneous ignition system, the waves for two cylinders in each group appear during wave observation. However, wave observation is carried out for the cylinder (Number 1 or 3) with the spark plug cable which has been clamped by the secondary pickup.*

*NOTE: Identification of which cylinder wave pattern is displayed can be difficult, but the wave pattern of the cylinder which is clamped by the secondary pickup will be stable, so this can be used as a reference.*

- Clamp the spark plug cable (Number 1 or 3) with the trigger pickup.

*NOTE: Clamp the same spark plug cable as the one which has been clamped by the secondary pickup.*

**STANDARD WAVE PATTERN**

Observation Conditions	
FUNCTION	SECONDARY
Pattern height	High (or low)
Pattern selector	Raster
Engine speed	Curb idle speed

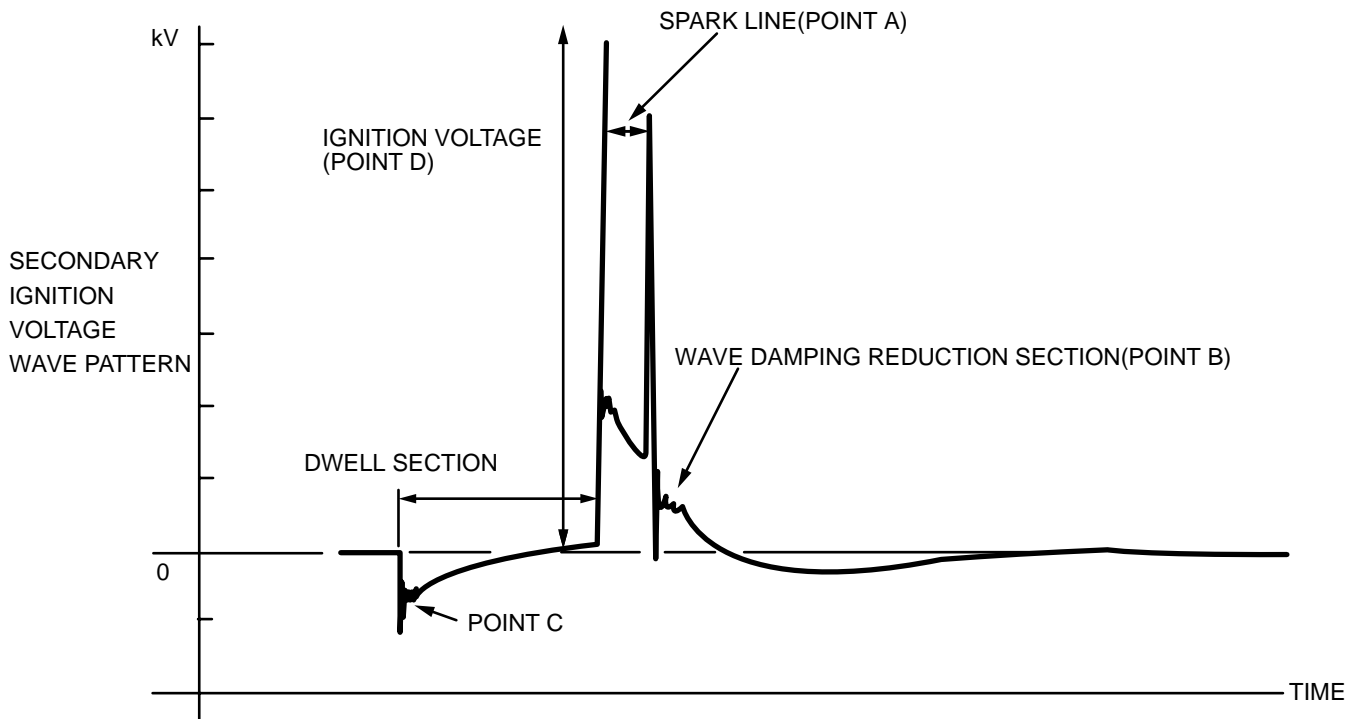

AKX00278AB

Observation Conditions	
Pattern selector	Display
Pattern height	High (or low)
Engine speed	Curb idle speed

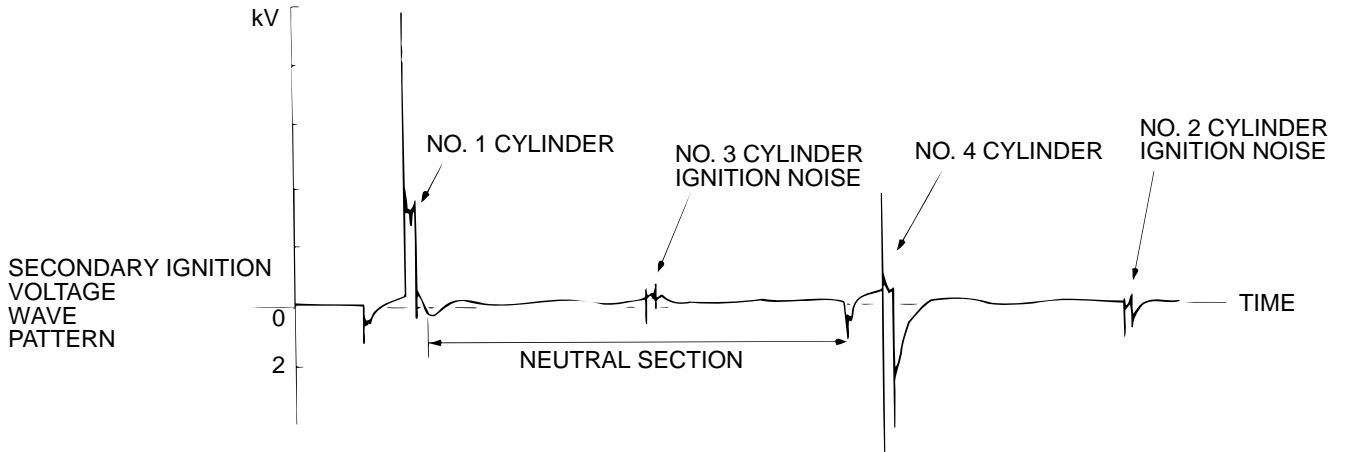

AKX01275AB

**WAVEFORM OBSERVATION POINTS**

*NOTE: Abnormal waveform examples are shown subsequently.*

Point A:

The height, length and slope of the spark line (refer to abnormal waveform examples 1, 2, 3 and 4) show the following trends.

SPARK LINE		PLUG GAP	CONDITION OF ELECTRODE	COMPRESSION FORCE	CONCENTRATION OF AIR MIXTURE	IGNITION TIMING	SPARK PLUG CABLE
Length	Long	Small	Normal	Low	Rich	Advanced	Leak
Length	Short	Large	Large wear	High	Lean	Retarded	High resistance
Height	High	Large	Large wear	High	Lean	Retarded	High resistance
Height	Low	Small	Normal	Low	Rich	Advanced	Leak
Slope		Large	Plug is fouled	-	-	-	-

Point B:

Number of vibrations in reduction vibration section (Refer to Abnormal Waveform Example 5)

NUMBER OF VIBRATIONS	COIL AND CAPACITOR
Three or more	Normal
Except above	Abnormal

TSB Revision

Point C:

Number of vibrations at beginning of dwell section (Refer to Abnormal Waveform Example 5)

NUMBER OF VIBRATIONS	COIL
5 – 6 or higher	Normal
Except above	Abnormal

Point D:

Ignition voltage height (distribution per each cylinder) shows the following trends.

IGNITION VOLTAGE	PLUG GAP	CONDITION OF ELECTRODE	COMPRESSION FORCE	CONCENTRATION OF AIR MIXTURE	IGNITION TIMING	SPARK PLUG CABLE
High	Large	Large wear	High	Lean	Retarded	High resistance
Low	Small	Normal	Low	Rich	Advanced	Leak

**ABNORMAL WAVEFORMS EXAMPLES**

**Example 1**

- Wave characteristics  
Spark line is high and short.
- Cause of problem  
Spark plug gap is too large.

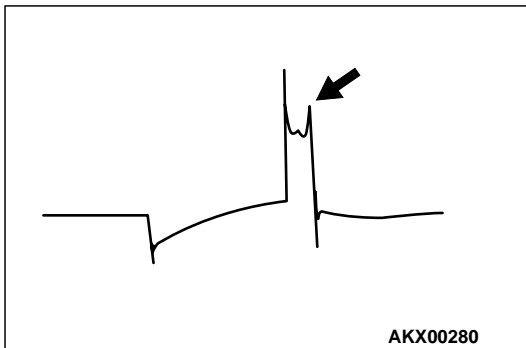

**Example 2**

- Wave characteristics  
Spark line is low and long, and is sloping. Also, the second half of the spark line is distorted. This could be a result of misfiring.
- Cause of problem  
Spark plug gap is too small.

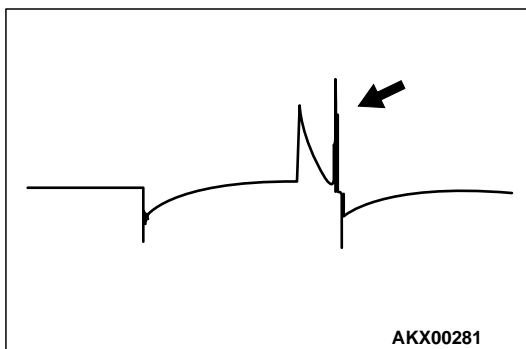

**Example 3**

- Wave characteristics  
Spark line is low and long, and is sloping. However, there is almost no spark line distortion.
- Cause of problem  
Spark plug gap is fouled.

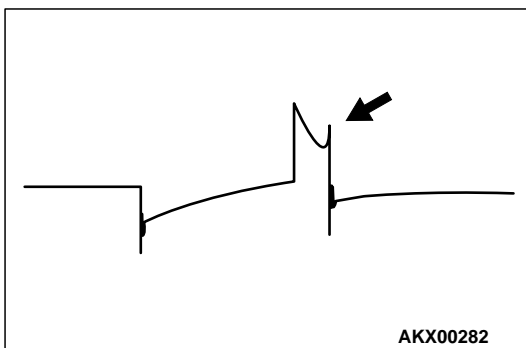

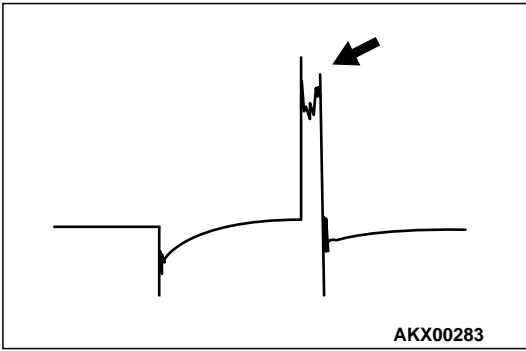

**Example 4**

- Wave characteristics  
Spark line is high and short. Difficult to distinguish between this and abnormal wave pattern example 1.
- Cause of problem  
Spark plug cable is not properly connected. (Causing a dual ignition)

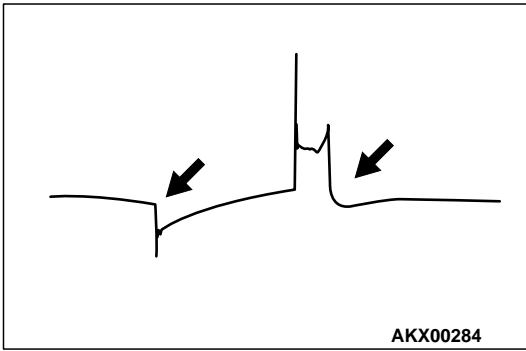

**Example 5**

- Wave characteristics  
No waves in wave damping section
- Cause of problem  
Layer short in ignition coil.

**<3.0L ENGINE>**

**MEASUREMENT METHOD**

1. Clamp the spark plug cable of the number 1 cylinder with the secondary pickup and check the wave patterns for each cylinder.
2. Connect the secondary pickup to the other cylinder in turn and check the wave patterns for each cylinder.

**STANDARD WAVE PATTERN**

OBSERVATION CONDITIONS	
FUNCTION	SECONDARY
Pattern height	High (or low)
Pattern selector	Raster
Engine speed	Curb idle speed



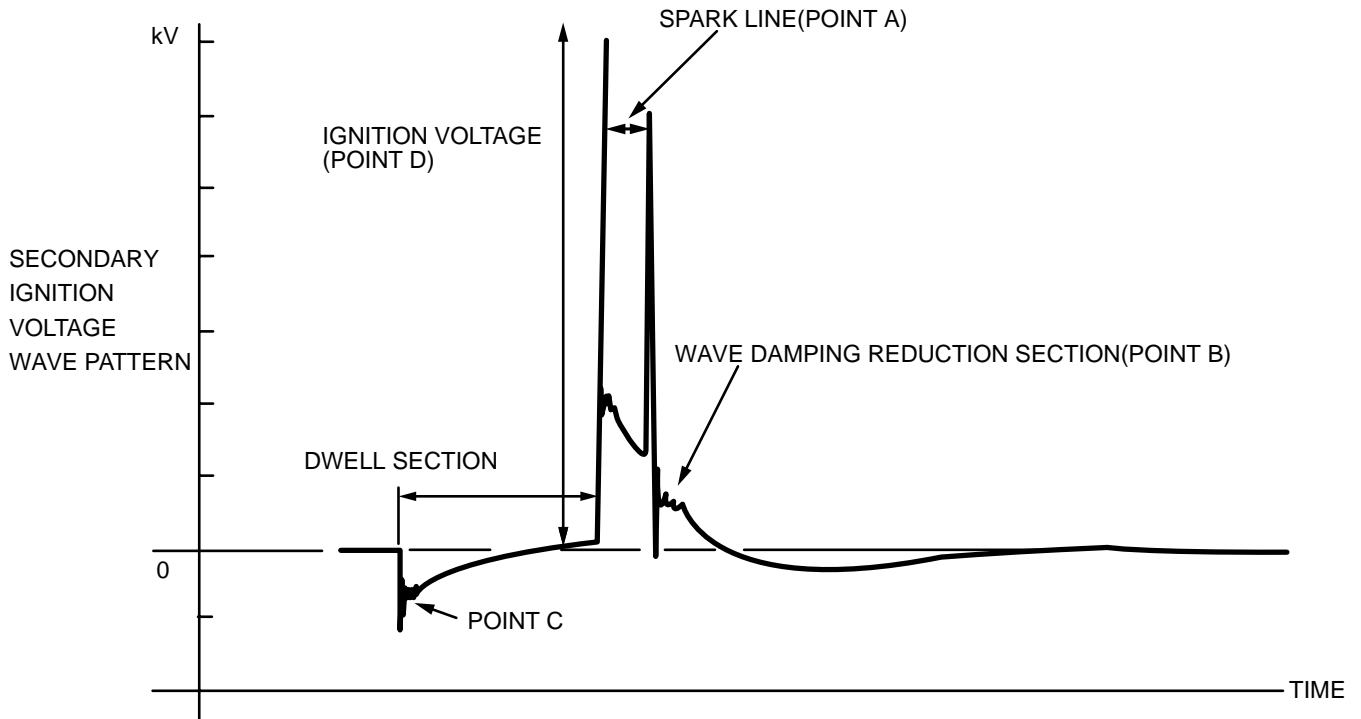

AKX00278 AB

**WAVEFORM OBSERVATION POINTS**

*NOTE: Abnormal waveform examples are shown subsequently.*

Point A:

The height, length and slope of the spark line (refer to abnormal waveform examples 1, 2, 3 and 4) show the following trends.

SPARK LINE		PLUG GAP	CONDITION OF ELECTRODE	COMPRESSION FORCE	CONCENTRATION OF AIR MIXTURE	IGNITION TIMING	SPARK PLUG CABLE
Length	Long	Small	Normal	Low	Rich	Advanced	Leak
Length	Short	Large	Large wear	High	Lean	Retarded	High resistance
Height	High	Large	Large wear	High	Lean	Retarded	High resistance
Height	Low	Small	Normal	Low	Rich	Advanced	Leak
Slope		Large	Plug is fouled	-	-	-	-

TSB Revision

Point B:

Number of vibrations in reduction vibration section (Refer to Abnormal Waveform Example 5)

NUMBER OF VIBRATIONS	COIL AND CAPACITOR
Three or more	Normal
Except above	Abnormal

Point C:

Number of vibrations at beginning of dwell section (Refer to Abnormal Waveform Example 5)

NUMBER OF VIBRATIONS	COIL
5 – 6 or higher	Normal
Except above	Abnormal

Point D:

Ignition voltage height (distribution per each cylinder) shows the following trends.

IGNITION VOLTAGE	PLUG GAP	CONDITION OF ELECTRODE	COMPRESSION FORCE	CONCENTRATION OF AIR MIXTURE	IGNITION TIMING	SPARK PLUG CABLE
High	Large	Large wear	High	Lean	Retarded	High resistance
Low	Small	Normal	Low	Rich	Advanced	Leak

**ABNORMAL WAVEFORMS EXAMPLES**

**Example 1**

- Wave characteristics  
Spark line is high and short.
- Cause of problem  
Spark plug gap is too large.

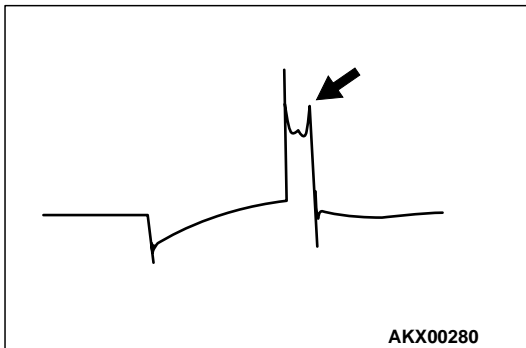

**Example 2**

- Wave characteristics  
Spark line is low and long, and is sloping. Also, the second half of the spark line is distorted. This could be a result of misfiring.
- Cause of problem  
Spark plug gap is too small.

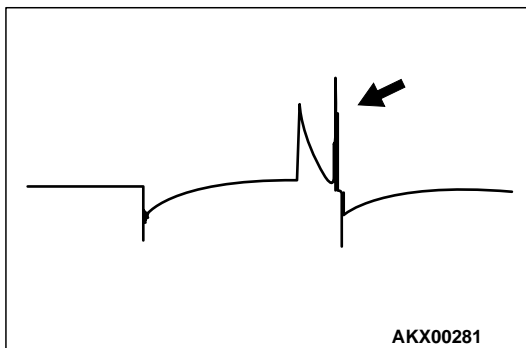

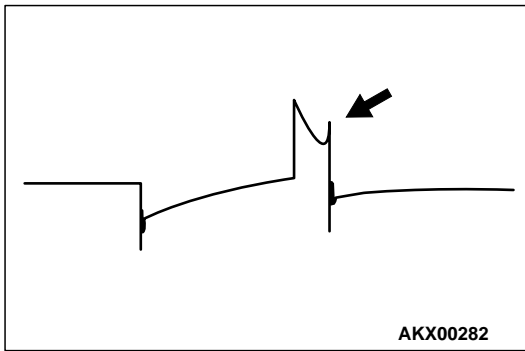

**Example 3**

- Wave characteristics  
Spark line is low and long, and is sloping. However, there is almost no spark line distortion.
- Cause of problem  
Spark plug gap is fouled.

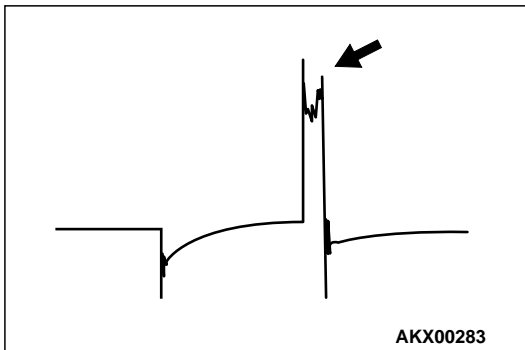

**Example 4**

- Wave characteristics  
Spark line is high and short. Difficult to distinguish between this and abnormal wave pattern example 1.
- Cause of problem  
Spark plug cable is not properly connected. (Causing a dual ignition)

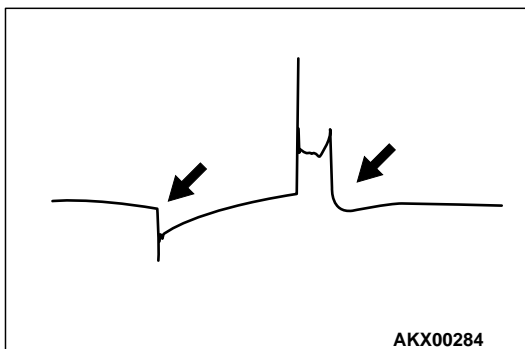

**Example 5**

- Wave characteristics  
No waves in wave damping section
- Cause of problem  
Layer short in ignition coil.

**IGNITION PRIMARY VOLTAGE WAVE PATTERN CHECK**

M1163004600020

**<3.0L ENGINE>**

**MEASUREMENT METHOD**

1. Disconnect the distributor connector and connect special tool (Test harness: MB991348) in between. (All of the terminals should be connected.)
2. Connect the analyzer primary pickup to the distributor connector terminal 2.
3. Connect the primary pickup ground terminal.
4. Clamp the spark plug cable with the trigger pickup.

*NOTE: The wave pattern of the cylinder clamped to the trigger pickup will appear at the left edge of the screen.*

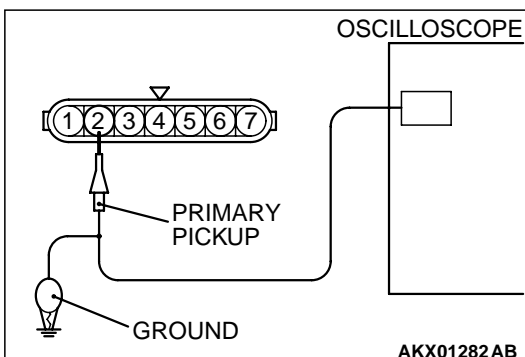

STANDARD WAVE PATTERN

OBSERVATION CONDITIONS	
FUNCTION	SECONDARY
Pattern height	High (or low)
Pattern selector	Raster
Engine speed	Curb idle speed

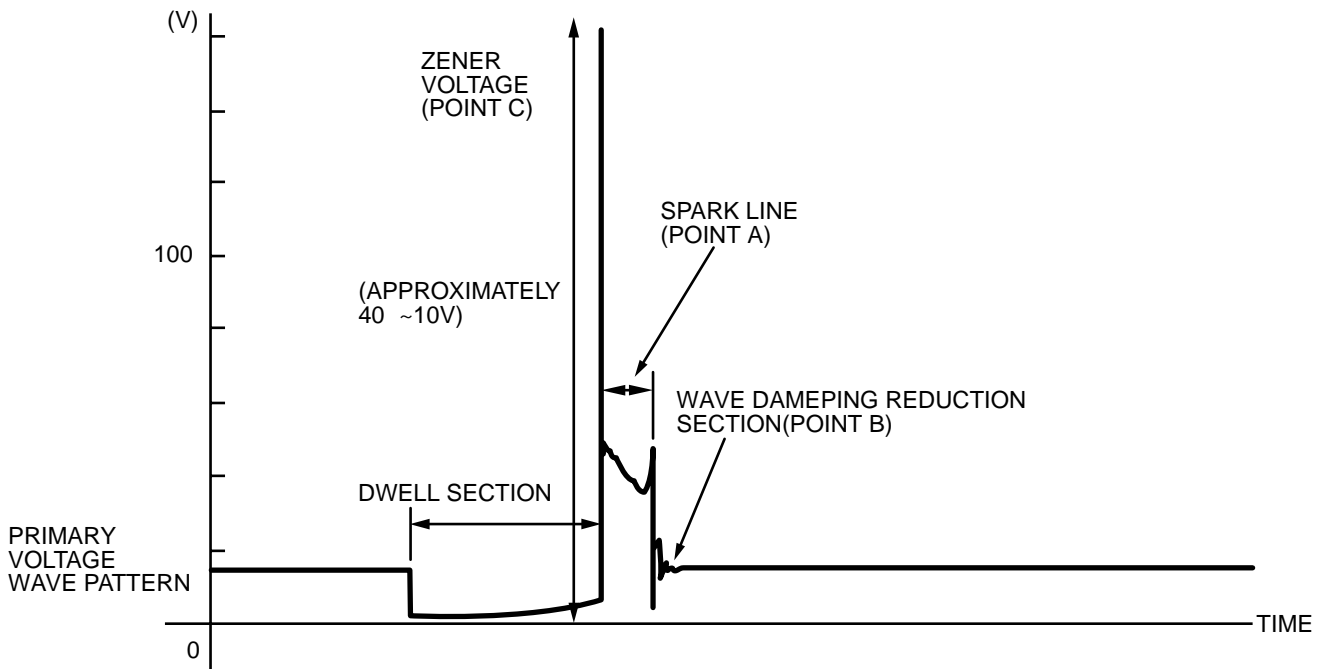

AKX00286 AB

OBSERVATION CONDITIONS	
Pattern selector	Display
Pattern height	High (or low)
Engine speed	Curb idle speed

TSB Revision

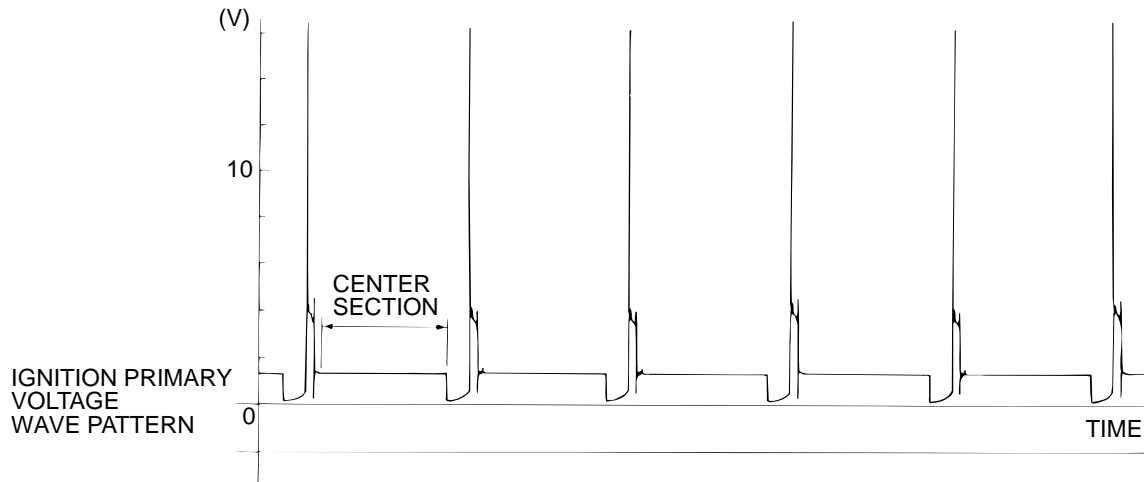

AKX01284AB

**WAVEFORM OBSERVATION POINTS**

*NOTE: Abnormal waveform examples are shown subsequently.*

Point A:

The height, length and slope of the spark line (refer to abnormal waveform examples 1, 2, 3 and 4) show the following trends.

SPARK LINE		PLUG GAP	CONDITION OF ELECTRODE	COMPRESSION FORCE	CONCENTRATION OF AIR MIXTURE	IGNITION TIMING	SPARK PLUG CABLE
Length	Long	Small	Normal	Low	Rich	Advanced	Leak
Length	Short	Large	Large wear	High	Lean	Retarded	High resistance
Height	High	Large	Large wear	High	Lean	Retarded	High resistance
Height	Low	Small	Normal	Low	Rich	Advanced	Leak
Slope		Large	Plug is fouled	-	-	-	-

Point B:

Number of vibrations in reduction vibration section (Refer to Abnormal Waveform Example 5)

NUMBER OF VIBRATIONS	COIL, CAPACITOR
Three or higher	Except above
Normal	Abnormal

Point C:

Height of Zener voltage

HEIGHT OF ZENER VOLTAGE	PROBABLE CAUSE
High	Problem in zener diode
Low	Abnormal resistance in primary coil circuit

**ABNORMAL WAVEFORMS EXAMPLES**

Example 1

- Wave characteristics  
Spark line is high and short.
- Cause of problem  
Spark plug gap is too large.

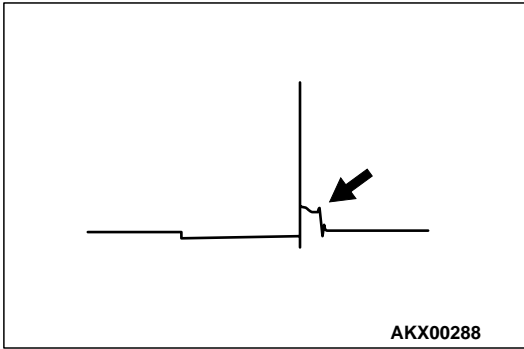

Example 2

- Wave characteristics  
Spark line is low and long, and is sloping. Also, the second half of the spark line is distorted. This could be a result of misfiring.
- Cause of problem  
Spark plug gap is too small.

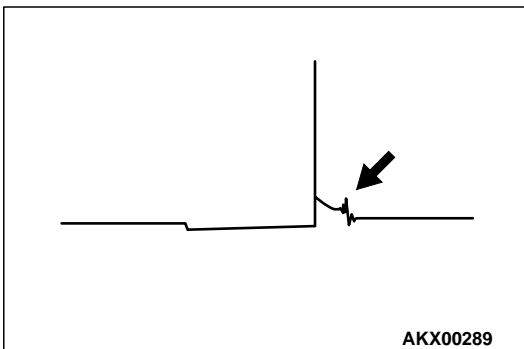

Example 3

- Wave characteristics  
Spark line is low and long, and is sloping. However, there is almost no spark line distortion.
- Cause of problem  
Spark plug gap is fouled.

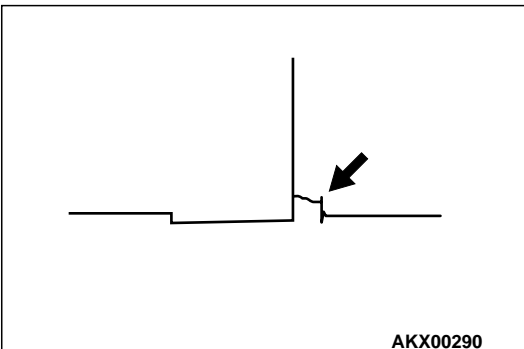

Example 4

- Wave characteristics  
Spark line is high and short
- Cause of problem  
Spark plug cable is not properly connected. (Causing a dual ignition)

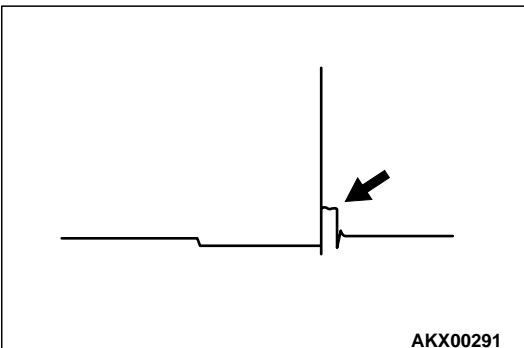

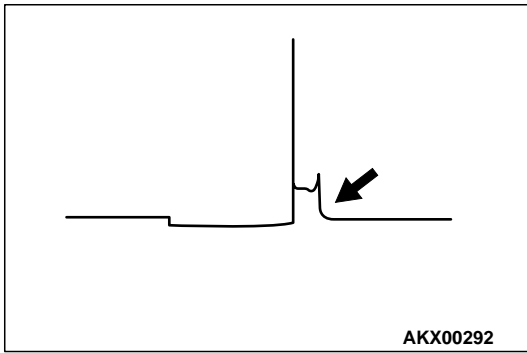

Example 5

- Wave characteristics  
No waves in wave damping section
- Cause of problem  
Layer short in ignition coil.

IGNITION COIL

REMOVAL AND INSTALLATION <2.4L ENGINE>

M1163004000040

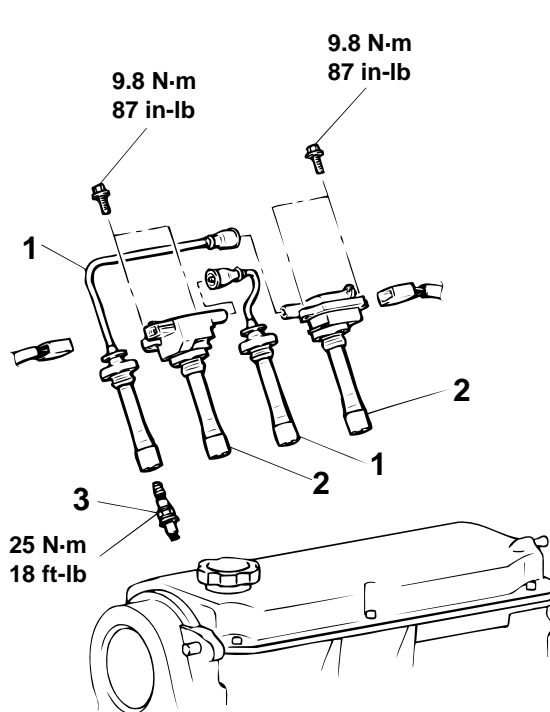

REMOVAL STEPS

1. SPARK PLUG CABLE
2. IGNITION COIL ASSEMBLY

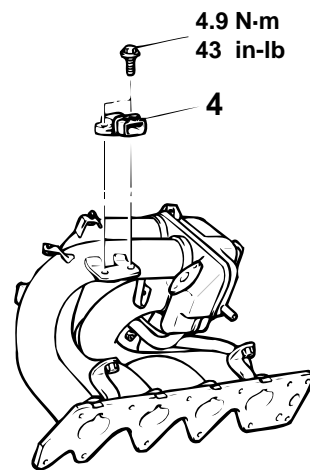

REMOVAL STEPS (Continued)

3. SPARK PLUG
4. IGNITION FAILURE SENSOR ASSEMBLY

AC000288AC

DISTRIBUTOR ASSEMBLY

REMOVAL AND INSTALLATION <3.0L ENGINE>

M1163002000055

<p><b>Pre-removal Operation</b></p> <ul style="list-style-type: none"> <li>• Air Cleaner Removal (Refer to GROUP 15 – Air Cleaner P.15-4.)</li> </ul>	<p><b>Post-installation Operation</b></p> <ul style="list-style-type: none"> <li>• Air Cleaner Installation (Refer to GROUP 15 – Air Cleaner P.15-4.)</li> <li>• Ignition Timing Check (Refer to GROUP 11C, On-vehicle Service – Ignition Timing Check P.11C-5.)</li> </ul>
---	---

TSB Revision

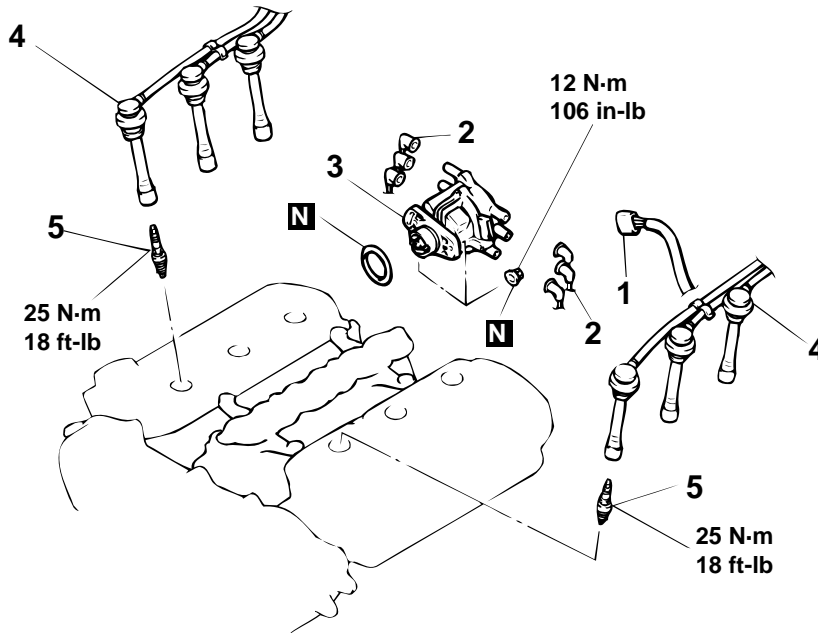

AC000289AC

**REMOVAL STEPS**

1. DISTRIBUTOR CONNECTOR
2. SPARK PLUG CABLE CONNECTION
- >>A<< 3. DISTRIBUTOR

**REMOVAL STEPS (Continued)**

- INTAKE MANIFOLD PLENUM (REFER TO GROUP 15 – INTAKE MANIFOLD PLENUM P.15-5.)
- 4. SPARK PLUG CABLE
- 5. SPARK PLUG

**INSTALLATION SERVICE POINT**

**>>A<< DISTRIBUTOR INSTALLATION**

1. Set the number 1 cylinder to top dead compression center.
2. Align the mating marks on the distributor housing and coupling, and then install the distributor to the engine.
3. Check that the ignition timing is at the standard value. (Refer to GROUP 11C, On-vehicle-Service - Ignition Timing Check P.11C-5.)

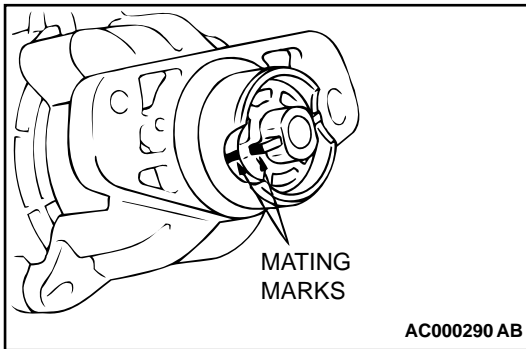

AC000290 AB



DISASSEMBLY AND ASSEMBLY

M1163002200059

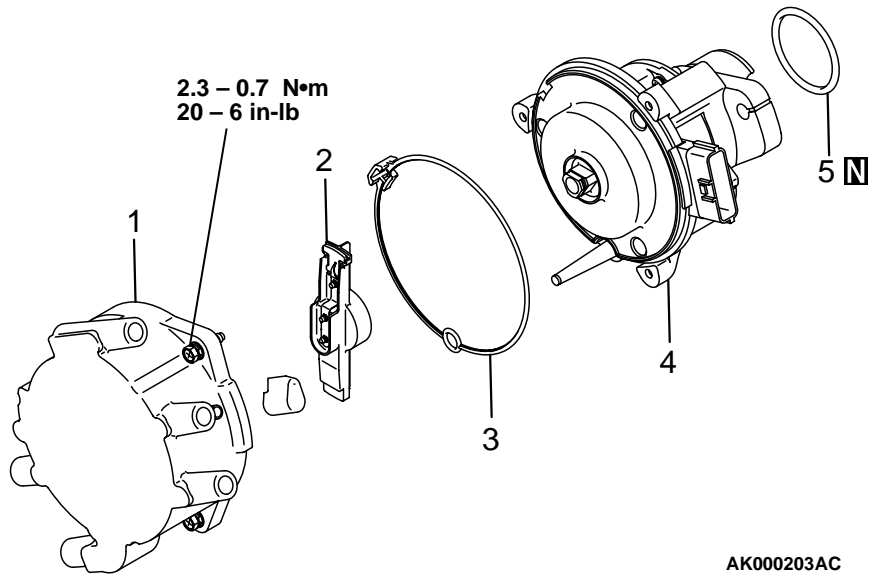

- DISASSEMBLY STEPS**
1. DISTRIBUTOR CAP
  2. ROTOR
  3. PACKING

- DISASSEMBLY STEPS**
4. DISTRIBUTOR HOUSING
  5. O-RING

**CAMSHAFT POSITION SENSOR  
REMOVAL AND INSTALLATION <2.4L ENGINE>**

M1163003400089

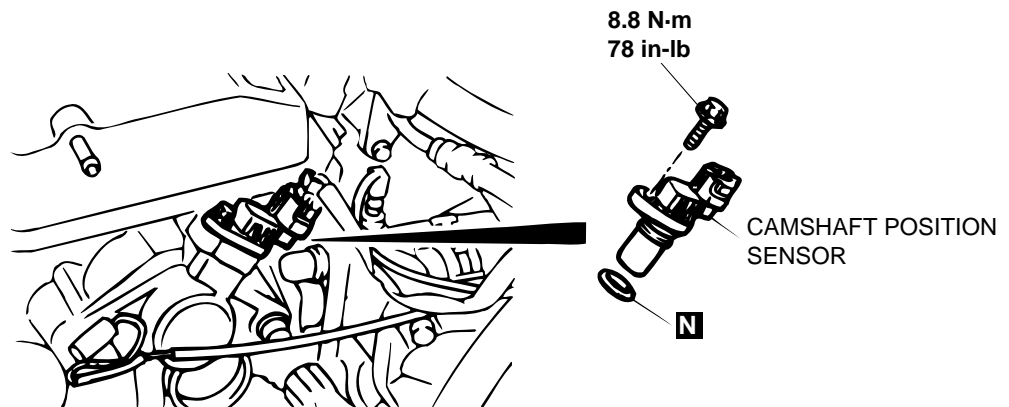

TSB Revision

**CRANKSHAFT POSITION SENSOR**

**REMOVAL AND INSTALLATION <2.4L ENGINE>**

M1163003500086

**Pre-removal and Post-installation Operation**

- Timing Belt Removal and Installation (Refer to GROUP 11A, Timing Belt and Timing Belt B P.11A-30.)

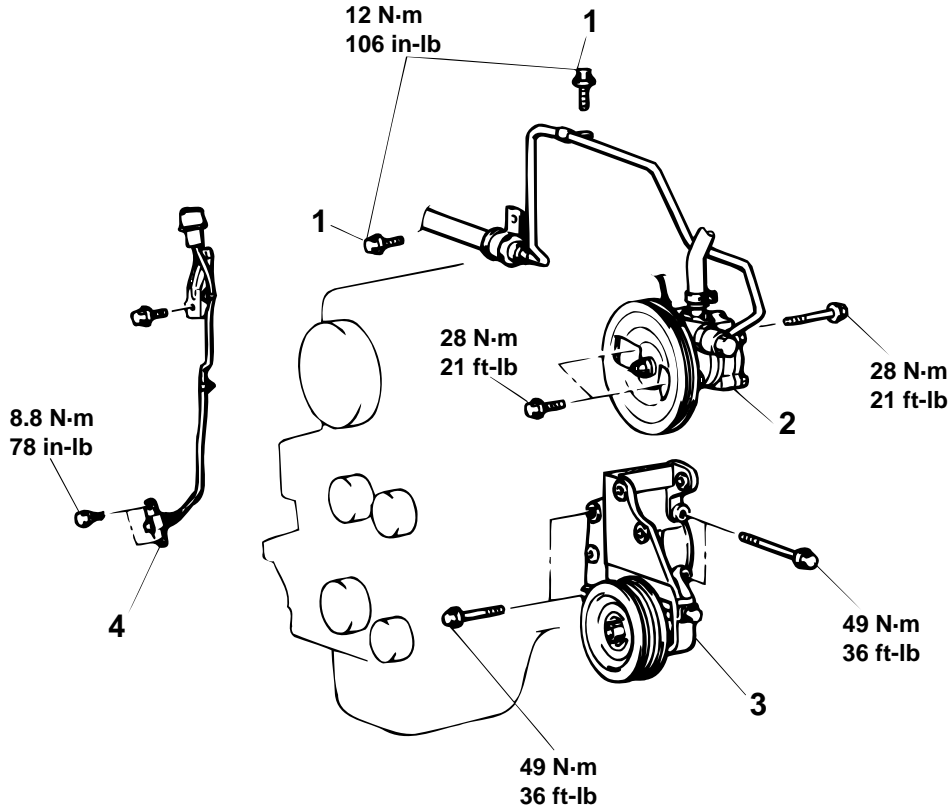

AC000292AC

**REMOVAL STEPS**

1. PRESSURE HOSE AND TUBE ASSEMBLY CONNECTION
2. POWER STEERING OIL PUMP ASSEMBLY

**REMOVAL STEPS (Continued)**

3. POWER STEERING OIL PUMP BRACKET
4. CRANKSHAFT POSITION SENSOR

TSB Revision

REMOVAL AND INSTALLATION <3.0L ENGINE>

M1163003500097

**Pre-removal and Post-installation Operation**

- Timing Belt Removal and Installation (Refer to GROUP 11C, Timing Belt [P.11C-29](#).)

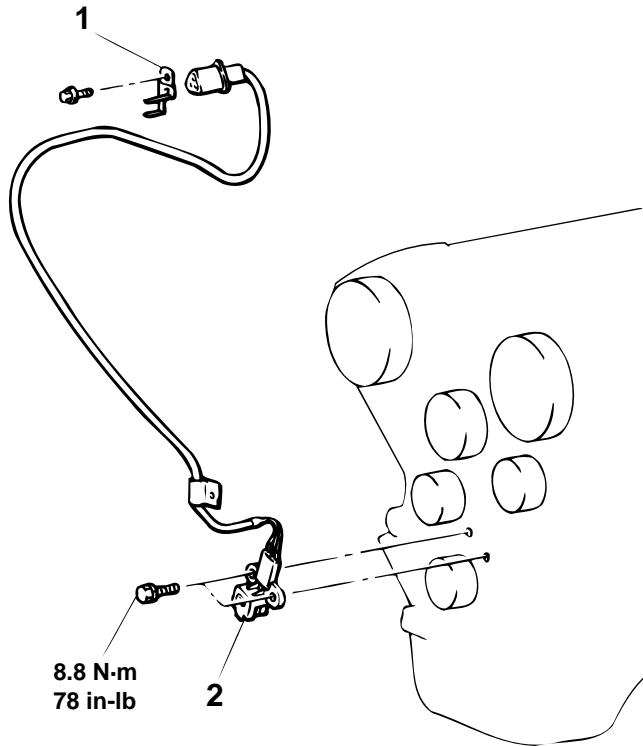

AC000293AC

**REMOVAL STEPS**

1. CLIP
2. CRANKSHAFT POSITION SENSOR

TSB Revision

**KNOCK SENSOR**

**REMOVAL AND INSTALLATION <3.0L ENGINE>**

M1163002800084

**CAUTION**

Do not drop or hit the knock sensor against other components. Internal damage may result, and the knock sensor will need to be replaced.

- Pre-removal and Post-installation Operation**
- Air Cleaner Removal and Installation (Refer to GROUP 15, Air Cleaner P.15-4.)
  - Intake Manifold Stay Removal and Installation (Refer to GROUP 15, Intake Manifold P.15-10.)

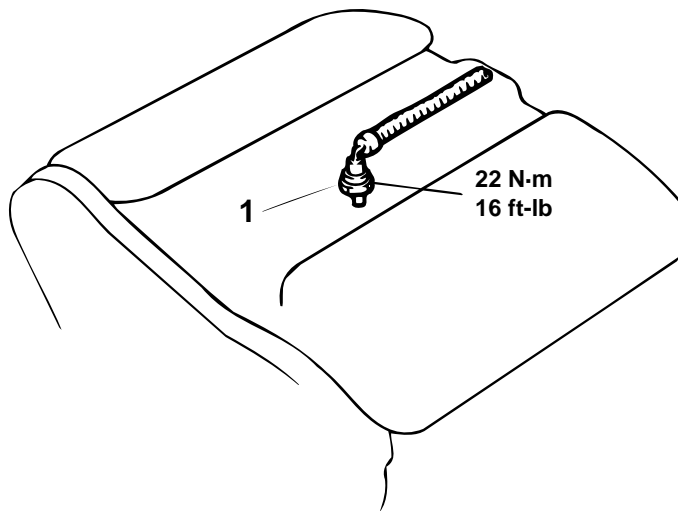

AC004371AB

<<A>> >>A<< 1. KNOCK SENSOR

**Required Special Tool:**  
MD998773: Knock Sensor Wrench

**REMOVAL SERVICE POINT**

<<A>> **KNOCK SENSOR REMOVAL**

Use special tool MD998773 to removal the knock sensor.

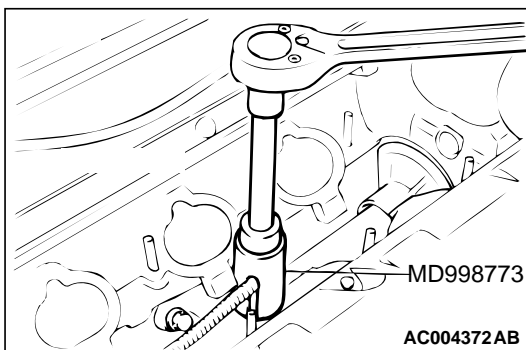

**INSTALLATION SERVICE POINT**

>>A<< **KNOCK SENSOR INSTALLATION**

Use special tool MD998773 to install the knock sensor.

TSB Revision

## SPECIFICATIONS

### FASTENER TIGHTENING SPECIFICATIONS

M1161002100067

ITEM	SPECIFICATION
Charging system	
Bearing retainer	3.7 N·m (33 in-lb)
Front bracket assembly bolt	4.4 N·m (39 in-lb)
Generator bolt<2.4L ENGINE>	20 – 25 N·m (15 – 18 ft-lb)
Generator bolt<3.0L ENGINE>	21 N·m (15 ft-lb)
Generator brace bolt<2.4L ENGINE>	23 N·m (17 ft-lb)
Generator brace bolt<2.4L ENGINE>	9 N·m (80 in-lb)
Generator brace bolt<3.0L ENGINE>	49 N·m (36 ft-lb)
Generator nut	44 N·m (32 ft-lb)
Oil level gauge unit bolt<3.0L ENGINE>	14 N·m (117 in-lb)
Oil pressure hose and tube clamp bolt<2.4L ENGINE>	12 N·m (106 in-lb)
Oil return tube clamp bolt<2.4L ENGINE>	12 N·m (106 in-lb)
Regulator assembly	3.7 N·m (33 in-lb)
Starting system	
Brush holder screw	5.7 N·m (51 in-lb)
Cover nut	3.4 N·m (30 in-lb)
Cover bolt	5.8 N·m (52 in-lb)
Magnetic switch bolt	5.8 N·m (52 in-lb)
Rear bracket bolt	3.4 N·m (30 in-lb)
Starter bolt	30 N·m (22 ft-lb)
Starter cover bolt<2.4L ENGINE>	4.9 N·m (43 in-lb)
Starter screw	5.8 N·m (52 in-lb)
Ignition system	
Camshaft position sensor bolt<2.4L ENGINE>	8.8 N·m (78 in-lb)
Crankshaft position sensor bolt<2.4L ENGINE>	8.8 N·m (78 in-lb)
Crankshaft position sensor bolt<3.0L ENGINE>	8.8 N·m (78 in-lb)
Distributor cap<3.0L ENGINE>	2.3 N·m (20 in-lb)
Distributor nut<3.0L ENGINE>	12 N·m (106 in-lb)
Ignition coil bolt<2.4L ENGINE>	9.8 N·m (87 in-lb)
Ignition failure sensor bolt<2.4L ENGINE>	4.9 N·m (43 in-lb)
Knock sensor	22 N·m (16 ft-lb)
Power steering oil pump assembly bolt<2.4L ENGINE>	28 N·m (21 ft-lb)
Power steering oil pump bracket bolt<2.4L ENGINE>	49 N·m (36 ft-lb)
Pressure hose and tube connection bolt<2.4L ENGINE>	12 N·m (106 in-lb)
Spark plug	25 N·m (18 ft-lb)

TSB Revision

**GENERAL SPECIFICATIONS**

M1161000200068

**GENERATOR**

ITEMS	2.4L ENGINE	3.0L ENGINE
Type	Positive battery positive voltage sensing	Positive battery positive voltage sensing
Identification number	A2TB5791ZC	A3TB3491ZC
Part No.	MD368519	MD373093
Rated output V/A	12/85	12/85
Voltage regulator	Electronic built-in type	Electronic built-in type

**STARTER MOTOR**

ITEMS	2.4L ENGINE	3.0L ENGINE
Type	Reduction drive with planetary gear	Reduction drive with planetary gear
Identification number	M1T84883	M000T80783
Part No.	MD356178	MD351508
Rated output kW/V	1.4/12	1.2/12
No. of pinion teeth	8	8

**DISTRIBUTOR <3.0L Engine>**

ITEMS	SPECIFICATIONS
Type	Contact pointless with built-in ignition coil
Advance mechanism	Electronic
Firing order	1 – 2 – 3 – 4 – 5 – 6

**IGNITION COIL**

ITEMS	2.4L ENGINE	3.0L ENGINE
Type	Molded 2 coil	Molded single-coil built in distributor

**SPARK PLUGS**

ITEMS	2.4L ENGINE	3.0L ENGINE
NGK	BKR5E-11	PFR6G-11
DENSO	K16PR-U11	PK20PR11
CHAMPION	RC10YC4	RC8PYP4

**SERVICE SPECIFICATIONS**

M1161000300065

**GENERATOR**

ITEMS		STANDARD VALUE	LIMIT
Regulated voltage (Ambient temperature at voltage regulator)	-20°C (-4°F)	14.2 – 15.4	-
	20°C (68°F)	13.9 – 14.9	-
	60°C (140°F)	13.4 – 14.5	-
	80°C (176°F)	13.1 – 14.5	-

TSB Revision

ITEMS	STANDARD VALUE	LIMIT
Generator output line voltage drop (at 30A) V	-	Maximum 0.3
Output current	-	70% of normal output current
Field coil resistance $\Omega$	Approximately 2 – 5	-
Brush protrusion length mm (in)	-	Minimum 2 (0.08)

**STARTER MOTOR**

ITEMS	STANDARD VALUE	LIMIT	
Free running characteristics	Terminal voltage V	11	-
	Current A	90	-
	Speed r/min	3,000 or more	-
Pinion gap mm (in)	0.5 – 2.0 (0.02 – 0.07)	-	
Commutator run-out mm (in)	0.05 (0.002)	Minimum 0.1 (0.004)	
Commutator diameter mm (in)	29.4 (1.16)	Minimum 28.8 (1.13)	
Undercut depth mm (in)	0.5 (0.02)	Minimum 0.2 (0.008)	

**IGNITION PARTS**

ITEMS	STANDARD VALUE	LIMIT	
Ignition coil resistance at 20°C (68°F)	Primary coil $\Omega$	2.4L Engine	-
		3.0L Engine	0.56 – 0.68
	Secondary coil k $\Omega$	2.4L Engine	8.5 – 11.5
		3.0L Engine	9.4 – 12.8
Spark plug gap mm (in)	2.4L Engine	1.0 – 1.1 (0.039 – 0.043)	-
	3.0L Engine	1.0 – 1.1 (0.039 – 0.043)	1.3 (0.051)
Ignition failure sensor resistance $\Omega$	2.4L Engine	0.1 or less	-
Resistor wire resistance k $\Omega$	-	Maximum 22	

---

## NOTES