

## GROUP 23B

# AUTOMATIC TRANSAXLE OVERHAUL

## CONTENTS

<b>GENERAL DESCRIPTION</b> .....	<b>23B-2</b>	<b>SECOND BRAKE DISASSEMBLY AND ASSEMBLY</b> .....	<b>23B-61</b>
<b>SPECIAL TOOLS</b> .....	<b>23B-5</b>	<b>OUTPUT SHAFT</b> .....	<b>23B-62</b>
<b>TRANSAXLE</b> .....	<b>23B-10</b>	OUTPUT SHAFT DISASSEMBLY AND ASSEMBLY .....	23B-62
TRANSAXLE DISASSEMBLY AND ASSEMBLY .....	23B-10	<b>DIFFERENTIAL</b> .....	<b>23B-64</b>
<b>OIL PUMP</b> .....	<b>23B-50</b>	DIFFERENTIAL DISASSEMBLY AND ASSEMBLY .....	23B-64
OIL PUMP DISASSEMBLY AND ASSEMBLY .....	23B-50	<b>VALVE BODY</b> .....	<b>23B-68</b>
<b>UNDERDRIVE CLUTCH AND INPUT SHAFT</b> .....	<b>23B-51</b>	VALVE BODY DISASSEMBLY AND ASSEMBLY .....	23B-68
UNDERDRIVE CLUTCH AND INPUT SHAFT DISASSEMBLY AND ASSEMBLY.....	23B-51	<b>SPEEDOMETER GEAR</b> .....	<b>23B-72</b>
<b>REVERSE AND OVERDRIVE CLUTCH</b> .....	<b>23B-53</b>	SPEEDOMETER GEAR DISASSEMBLY AND ASSEMBLY.....	23B-72
REVERSE AND OVERDRIVE CLUTCH DISASSEMBLY AND ASSEMBLY.....	23B-53	<b>DRIVE SHAFT OIL SEAL</b> .....	<b>23B-73</b>
<b>PLANETARY GEAR</b> .....	<b>23B-58</b>	DRIVE SHAFT OIL SEAL DISASSEMBLY AND ASSEMBLY.....	23B-73
PLANETARY GEAR DISASSEMBLY AND ASSEMBLY .....	23B-58	<b>SPECIFICATIONS</b> .....	<b>23B-75</b>
<b>LOW-REVERSE BRAKE</b> .....	<b>23B-60</b>	TORQUE SPECIFICATION.....	23B-75
LOW-REVERSE BRAKE DISASSEMBLY AND ASSEMBLY.....	23B-60	GENERAL SPECIFICATIONS.....	23B-75
<b>SECOND BRAKE</b> .....	<b>23B-61</b>	SERVICE SPECIFICATIONS.....	23B-76
		VALVE BODY SPRING IDENTIFICATION .	23B-76
		ADJUSTING PLATE, SNAP RING AND SPACERS .....	23B-77
		SEALANTS AND ADHESIVES.....	23B-80

## GENERAL INFORMATION

M1233000100038

This automatic transaxle is made up of the following main parts.

The torque converter employs a 3 element, 1 step, 2 phase lock-up clutch.

The gear train is made up of 3 multi-plate clutches, 2 multi-plate brakes and 2 planetary gears made up of a sun gear, carrier, pinion gear and annulus gear.

The cases consist of a converter housing, transaxle case, rear cover and a valve body cover.

Parts related to oil pressure regulation are the oil pump, which pressurizes the oil; the regulator, which controls the pressure setting; the solenoid valve, which changes the oil pressure with electrical signals; the pressure control valve, which controls the oil pressure coming from the solenoid valve that effects each clutch and brake; each kind of valve, which carry out the retention of the oil pressure through the lines; and finally the valve body, which houses all the valves.

### SECTIONAL VIEW

<F4A42>

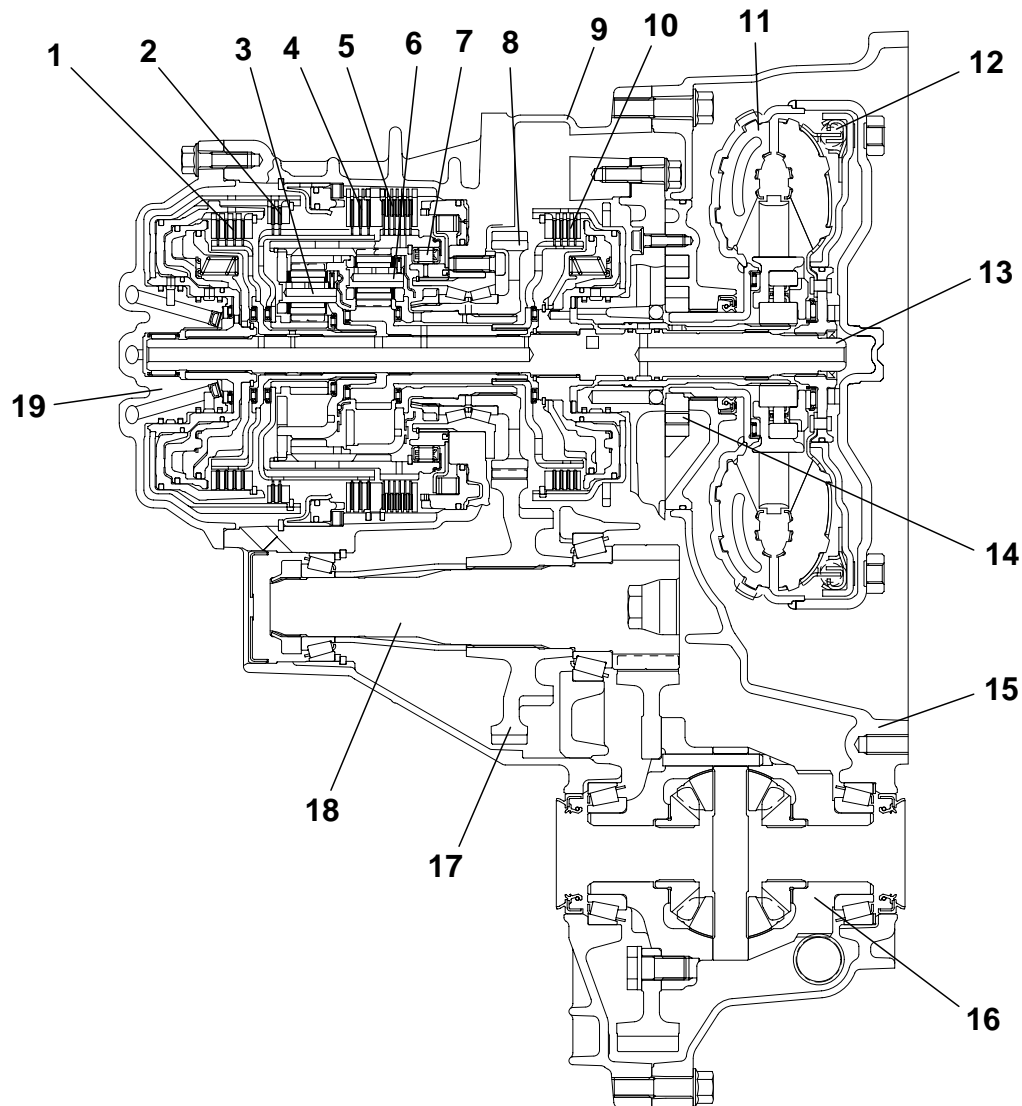

AKX01131AB

- |                                |                             |
|--------------------------------|-----------------------------|
| 1. REVERSE CLUTCH              | 4. LOW-REVERSE BRAKE        |
| 2. OVERDRIVE PLANETARY CARRIER | 5. OUTPUT PLANETARY CARRIER |
| 3. SECOND BRAKE                | 6. ONE-WAY CLUTCH           |

TSB Revision

- 7. TRANSFER DRIVE GEAR
- 8. TRANSAXLE CASE
- 9. UNDERDRIVE CLUTCH
- 10. TORQUE CONVERTER
- 11. TORQUE CONVERTER CLUTCH
- 12. INPUT SHAFT
- 13. OIL PUMP
- 14. CONVERTER HOUSING
- 15. DIFFERENTIAL
- 16. TRANSFER DRIVEN GEAR
- 17. OUTPUT SHAFT
- 18. REAR COVER
- 19. OVERDRIVE CLUTCH

<F4A51>

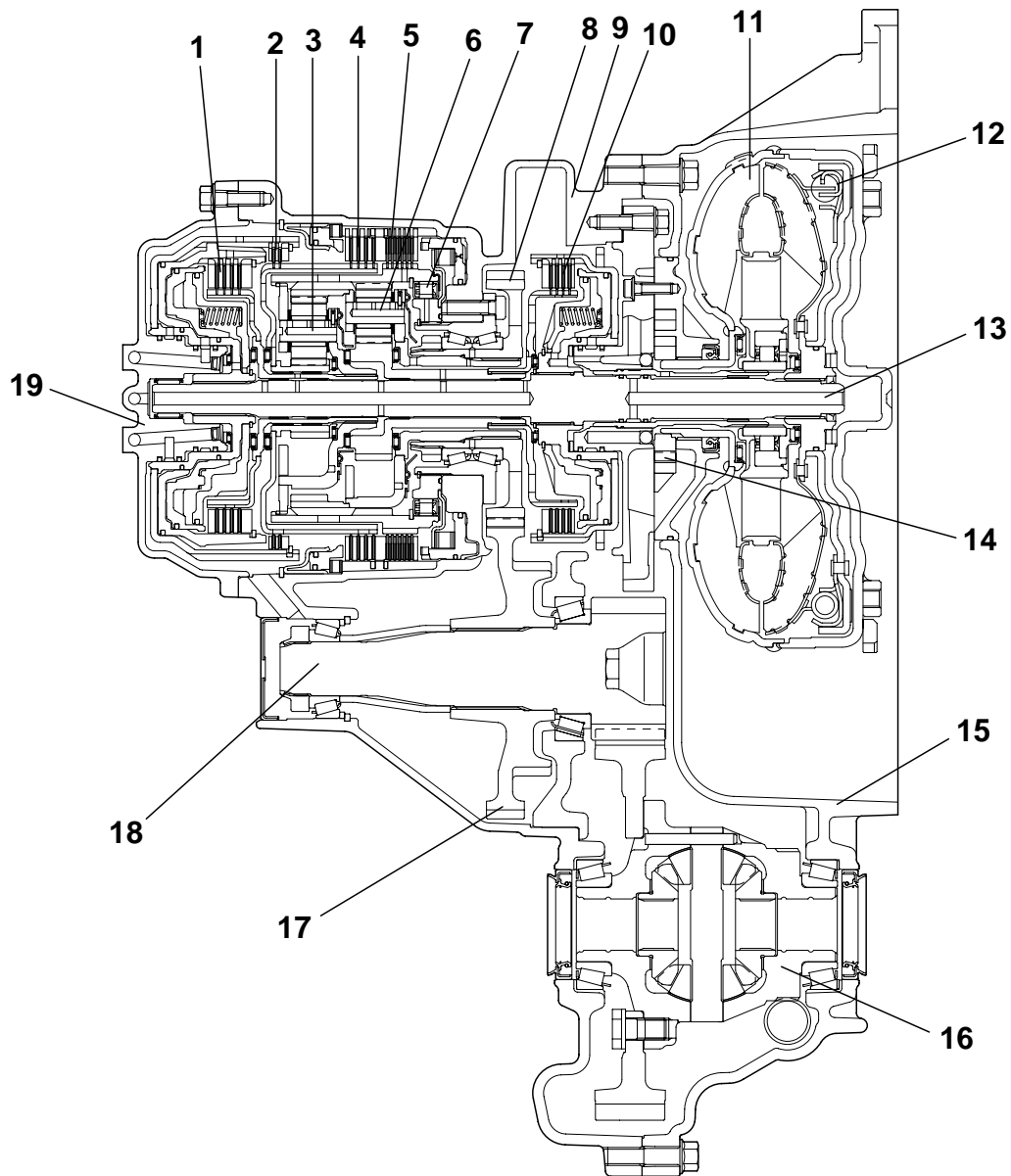

AKX01109 AB

- |                                |                             |
|--------------------------------|-----------------------------|
| 1. REVERSE CLUTCH              | 6. ONE-WAY CLUTCH           |
| 2. OVERDRIVE PLANETARY CARRIER | 7. TRANSFER DRIVE GEAR      |
| 3. SECOND BRAKE                | 8. TRANSAXLE CASE           |
| 4. LOW-REVERSE BRAKE           | 9. UNDERDRIVE CLUTCH        |
| 5. OUTPUT PLANETARY CARRIER    | 10. TORQUE CONVERTER        |
|                                | 11. TORQUE CONVERTER CLUTCH |

**TSB Revision**

- 12. INPUT SHAFT
- 13. OIL PUMP
- 14. CONVERTER HOUSING
- 15. DIFFERENTIAL
- 16. TRANSFER DRIVEN GEAR
- 17. OUTPUT SHAFT
- 18. REAR COVER
- 19. OVERDRIVE CLUTCH

HYDRAULIC CIRCUIT

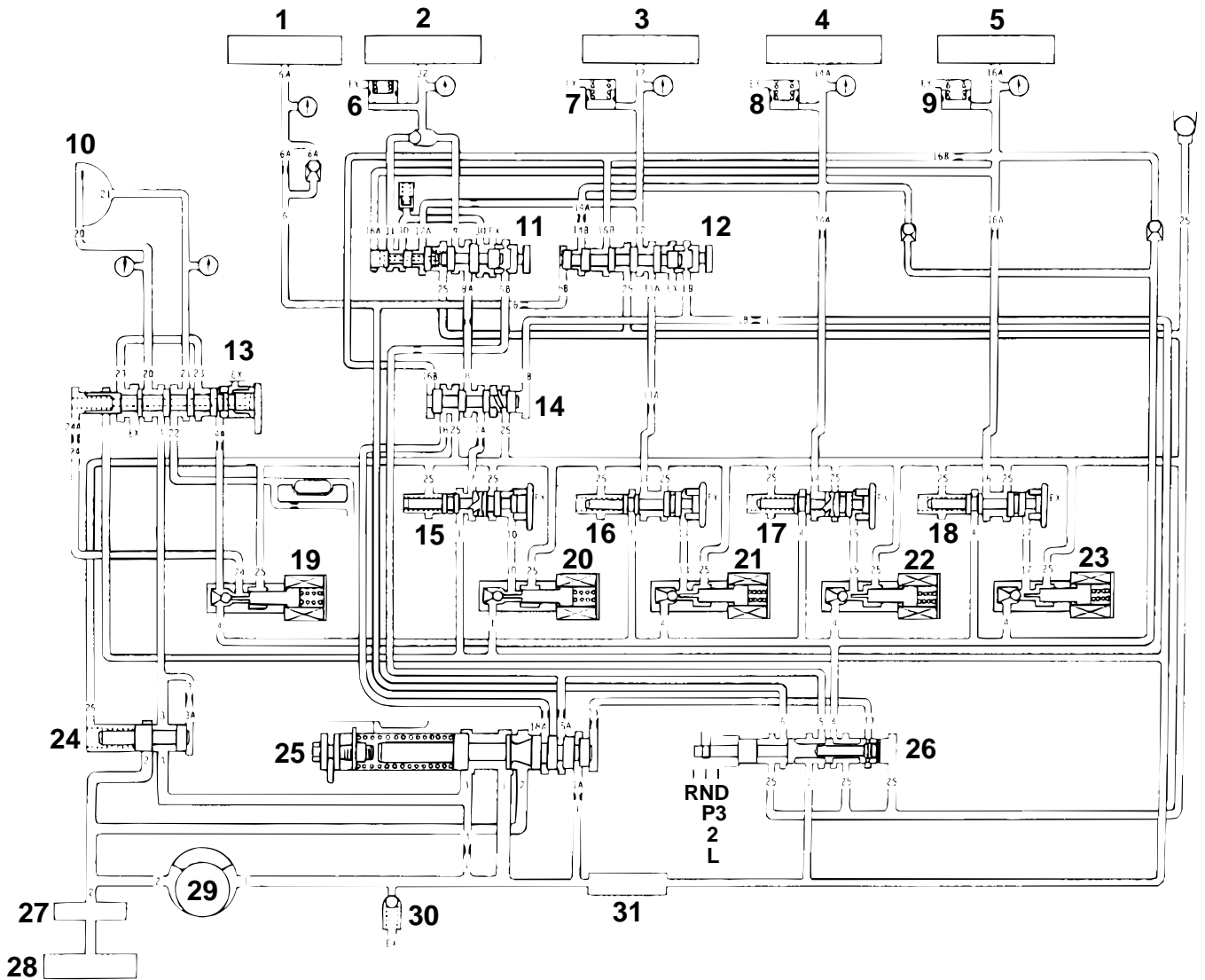

AKX00963AB

- 1. REVERSE CLUTCH
- 2. LOW-REVERSE BRAKE
- 3. SECOND BRAKE
- 4. UNDERDRIVE CLUTCH
- 5. OVERDRIVE CLUTCH
- 6. LOW-REVERSE ACCUMULATOR
- 7. SECOND ACCUMULATOR
- 8. UNDERDRIVE ACCUMULATOR
- 9. OVERDRIVE ACCUMULATOR
- 10. TORQUE CONVERTER CLUTCH
- 11. FAIL-SAFE VALVE A
- 12. FAIL-SAFE VALVE B
- 13. TORQUE CONVERTER CLUTCH CONTROL VALVE
- 14. SWITCHING VALVE
- 15. LOW-REVERSE PRESSURE CONTROL VALVE
- 16. SECOND PRESSURE CONTROL VALVE
- 17. UNDERDRIVE PRESSURE CONTROL VALVE
- 18. OVERDRIVE PRESSURE CONTROL VALVE
- 19. TORQUE CONVERTER CLUTCH CONTROL SOLENOID VALVE



TSB Revision







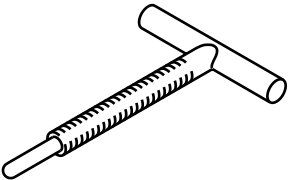
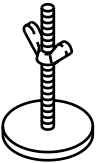
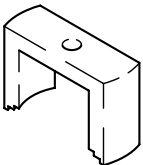

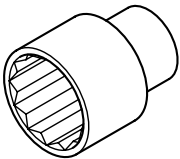
- 20. LOW-REVERSE SOLENOID VALVE
- 21. SECOND SOLENOID VALVE
- 22. UNDERDRIVE SOLENOID VALVE
- 23. OVERDRIVE SOLENOID VALVE
- 24. TORQUE CONVERTER PRESSURE CONTROL VALVE
- 25. REGULATOR VALVE
- 26. MANUAL VALVE
- 27. OIL FILTER
- 28. OIL PAN
- 29. OIL PUMP
- 30. RELIEF VALVE
- 31. OIL STRAINER

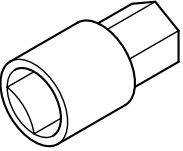
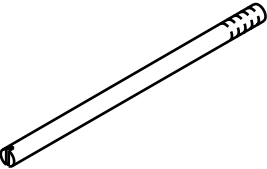
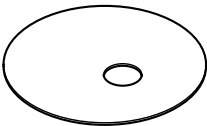
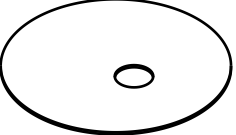
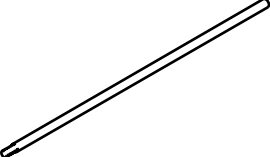
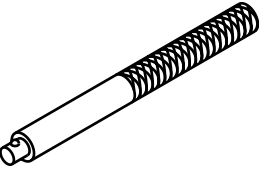
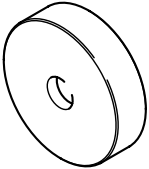
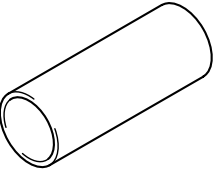
## SPECIAL TOOLS

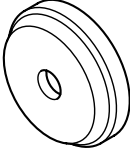
M1233000600033

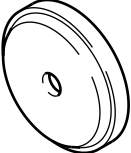
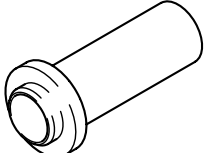
TOOL	TOOL NUMBER AND NAME	SUPERSESSION	APPLICATION
	MD998333 Oil pump remover	MD998333-01	Removal of oil pump
	MD998924 Spring compressor retainer	MD998924-01	Use with spring compressor
	MD998903 Spring compressor	MD998903	Removal and installation of one-way clutch inner race snap ring <F4A42>
	MD998338 Spring compressor	MD998338	Removal and installation of one-way clutch inner race snap ring <F4A51>
	MB991625 Socket (41)	MB991625-01 or General service tool	Removal and installation of transfer drive gear jam nut <F4A42>

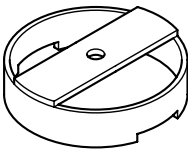
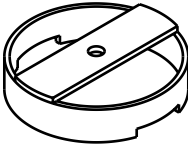
TOOL	TOOL NUMBER AND NAME	SUPERSESION	APPLICATION
	MB990607 Torque wrench socket	MB990607-01	Removal and installation of output shaft nut
	MD998412 Guide	MD998412	Installation of oil pump and transfer drive gear
	MB991631 Clearance dummy plate	MB991631-01	Measurement of reaction plate low-reverse brake and second brake end plays <F4A42>
	MB991632 Clearance dummy plate	MB991632-01	Measurement of reaction plate low-reverse brake and second brake end plays <F4A51>
	MD998913 Dial gauge extension	MD998913-01	Measurement of low-reverse brake end play
	MB990938 Handle	MB990938-01	<ul style="list-style-type: none"> <li>• Installation of input shaft rear bearing</li> <li>• Use with installer adapter</li> </ul>
	MB990930 Installer adapter	MB990930-01 or General service tool	Installation of output shaft taper roller bearing outer race
	MD998350 Bearing installer	MD998350-01	Installation of output shaft collar and taper roller bearing

TOOL	TOOL NUMBER AND NAME	SUPERSESION	APPLICATION
	MB990931 Installer adapter	MB990931-01 or General service tool	Installation of cap
	MB990935 Installer adapter	MB990935-01 or General service tool	Installation of differential taper roller bearing outer race <F4A42>
	MB990936 Installer adapter	MB990936-01 or General service tool	Installation of output shaft taper roller bearing outer race <F4A42> and differential taper roller bearing outer race <F4A51>
	MD998334 Oil seal installer	MD998334-01	Installation of oil pump oil seal
	MD998907 Spring compressor	MD998907-01	Removal and installation of underdrive clutch snap ring
	MB991628 Spring compressor	MB991628-01	Measurement of underdrive clutch and overdrive clutch end plays <F4A42>
	MB991629 Spring compressor	-	Measurement of underdrive clutch and overdrive clutch end plays <F4A51>
	MD999590 Spring compressor	MIT305039	Removal and installation of overdrive clutch snap ring

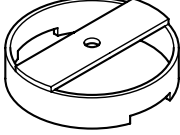
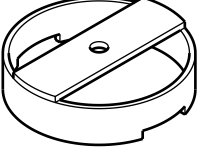
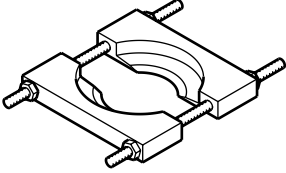
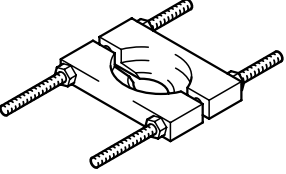
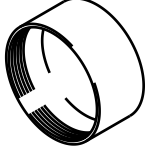
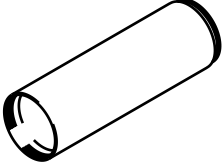
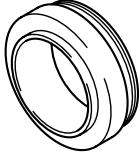
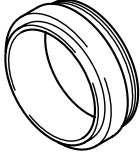
TOOL	TOOL NUMBER AND NAME	SUPERSESSSION	APPLICATION
	MB991790 Spring compressor	-	Measurement of reverse clutch end play <F4A42>
	MB991789 Spring compressor	-	Measurement of reverse clutch end play <F4A51>
	MD998917 Bearing remover	General service tool or MD998348-01	Removal of output shaft taper roller bearing and transfer driven gear<F4A42>
	MD998801 Bearing remover	MD998348-01	Removal of each bearing output shaft taper roller bearing (differential ball bearing)
	MD998812 Installer cap	General service tool	Use with installer and installer adapter
	MD998814 Installer – 200	MIT304180	Use with installer cap and installer adapter
	MD998823 Installer adapter (48)	General service tool	Installation of output shaft taper roller bearing <F4A42> and transfer driven gear <F4A42>
	MD998827 Installer adapter (56)	General service tool	Installation of output shaft taper roller bearing <F4A51>

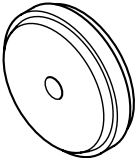
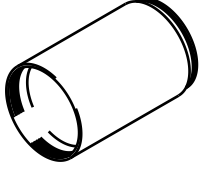
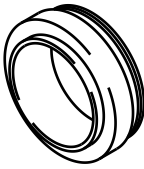
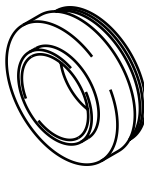
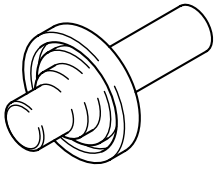
TOOL	TOOL NUMBER AND NAME	SUPERSESSSION	APPLICATION
	MB990937 Installer adapter	MB990937 or General service tool	Installation of output shaft taper roller bearing <F4A51>
	MD998813 Installer – 100	General service tool	Use with installer cap and installer adapter
	MD998824 Installer adapter (50)	General service tool	Installation of transfer driven gear <F4A51>, differential taper roller bearing <F4A51>
	MD998820 Installer adapter (42)	MIT215013	Installation of differential taper roller bearing
	MD998800 Oil seal installer	General service tool	Installation of driveshaft oil seal

TRANSAXLE

DISASSEMBLY AND ASSEMBLY

M123300100034

<F4A42>

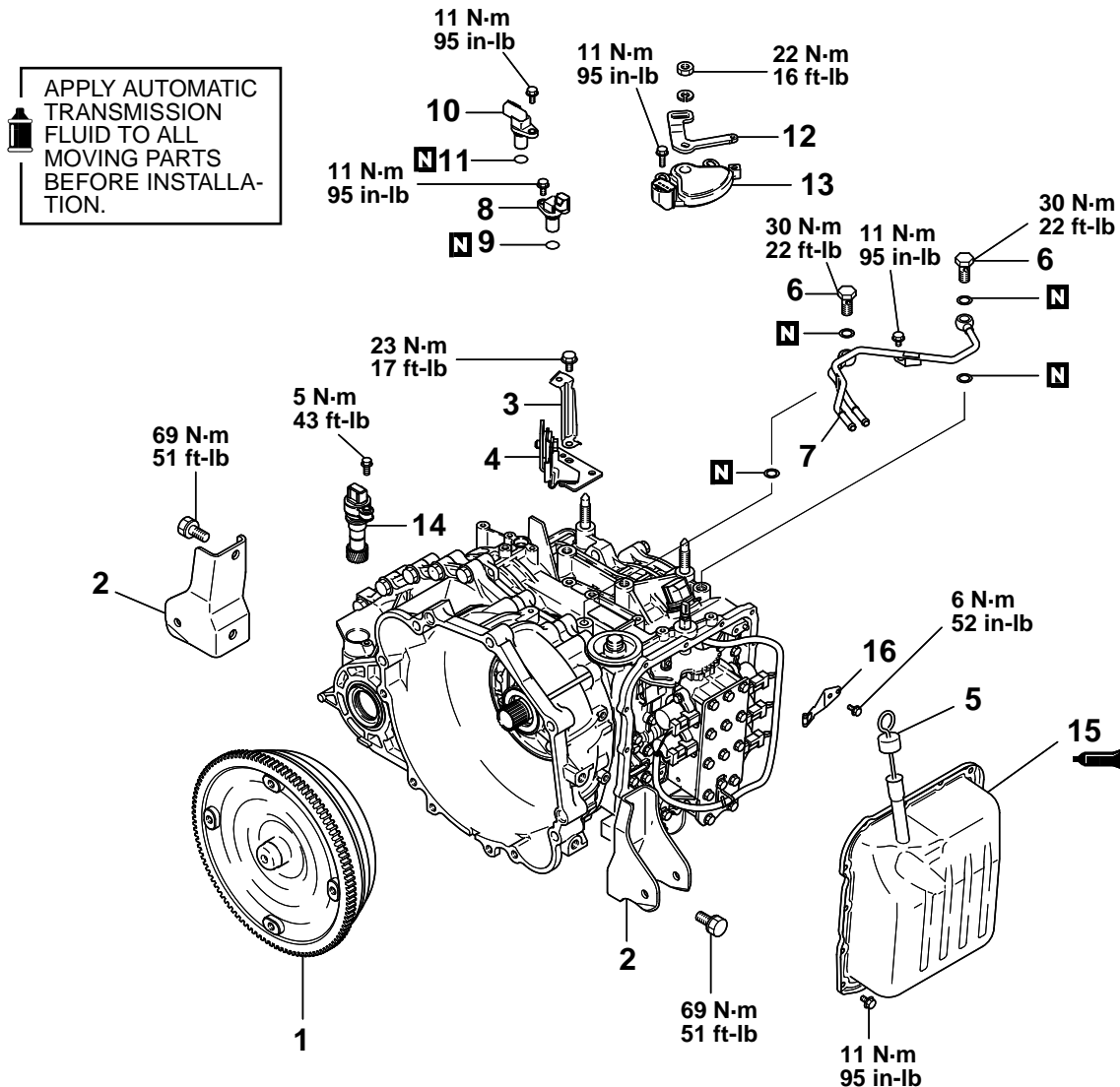

AKX01132AC

- |                                  |                                  |
|----------------------------------|----------------------------------|
| 1. TORQUE CONVERTER              | 9. O-RING                        |
| 2. ROLL STOPPER BRACKET          | 10. OUTPUT SHAFT SPEED SENSOR    |
| 3. HARNESS BRACKET               | 11. O-RING                       |
| 4. CONTROL CABLE SUPPORT BRACKET | 12. MANUAL CONTROL LEVER         |
| 5. OIL DIPSTICK                  | 13. PARK/NEUTRAL POSITION SWITCH |
| 6. EYE BOLT                      | 14. SPEEDOMETER GEAR             |
| 7. OIL COOLER FEED TUBE          | 15. VALVE BODY COVER             |
| 8. INPUT SHAFT SPEED SENSOR      | 16. MANUAL CONTROL SHAFT DETENT  |

**Required Special Tools:**

- MB990607: Torque Wrench Socket
- MB990930: Installer Adapter
- MB990931: Installer Adapter
- MB990935: Installer Adapter <F4A42>
- MB990936: Installer Adapter <F4A42>

- MB990938: Handle
- MB991625: Special Socket (41)
- MB991631: Clearance Dummy Plate <F4A42>
- MB991632: Clearance Dummy Plate <F4A51>
- MD998333: Oil Pump Remover
- MD998338: Spring Compressor <F4A51>

TSB Revision

MD998350: Bearing Installer  
 MD998412: Guide  
 MD998903: Spring Compressor <F4A42>

MD998913: Dial Gauge Extension  
 MD998924: Spring Compressor Retainer

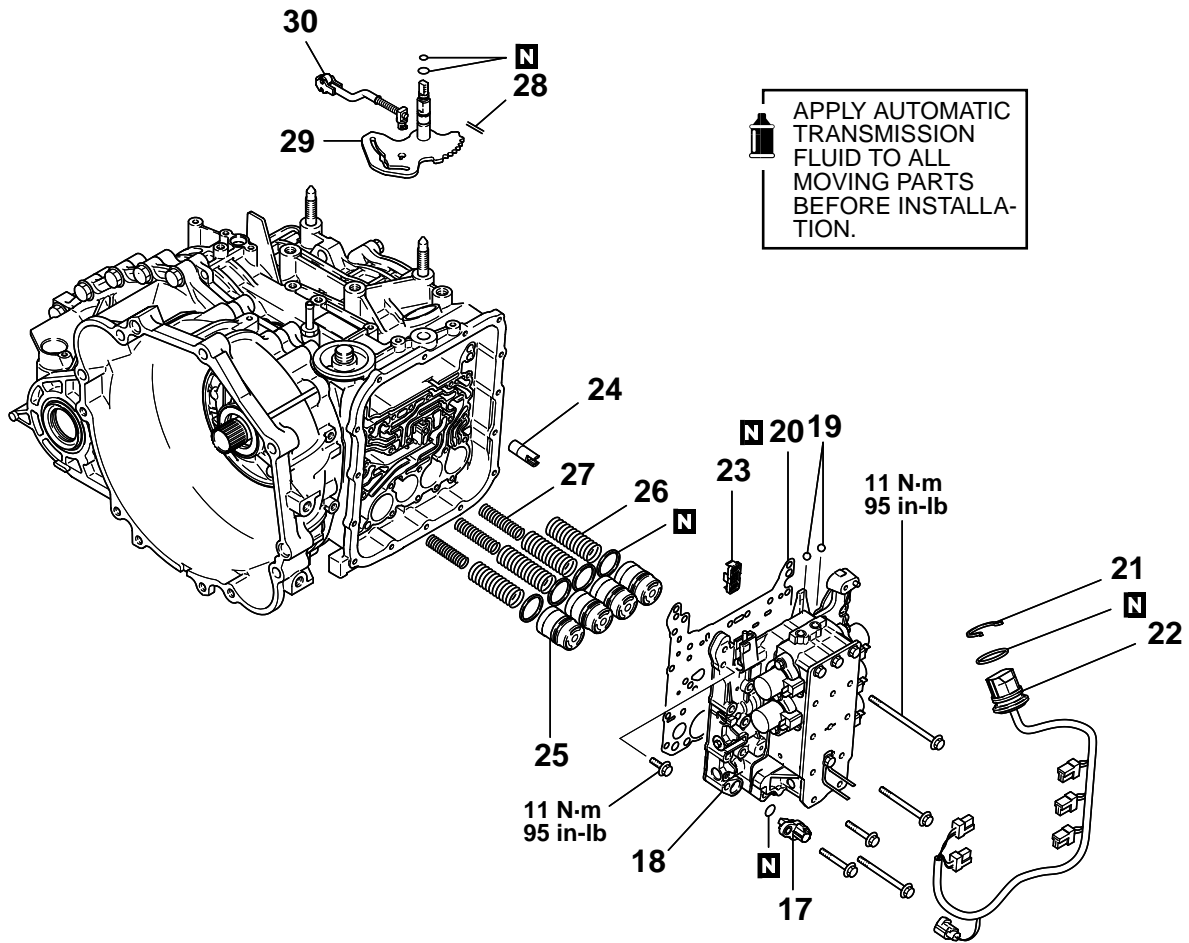

AKX01090AC

- |                                    |                                       |
|------------------------------------|---------------------------------------|
| 17. FLUID TEMPERATURE SENSOR       | 25. ACCUMULATOR PISTON                |
| 18. VALVE BODY                     | 26. ACCUMULATOR SPRING                |
| 19. STEEL BALL                     | 27. ACCUMULATOR SPRING                |
| 20. GASKET                         | 28. MANUAL CONTROL LEVER SHAFT ROLLER |
| 21. SNAP RING                      | 29. MANUAL CONTROL LEVER SHAFT        |
| 22. SOLENOID VALVE HARNESS         | 30. PARKING PAWL ROD                  |
| 23. STRAINER                       |                                       |
| 24. SECOND BRAKE RETAINER OIL SEAL |                                       |

**TSB Revision**

APPLY AUTOMATIC  
TRANSMISSION FLUID  
TO ALL MOVING PARTS  
BEFORE INSTALLATION.

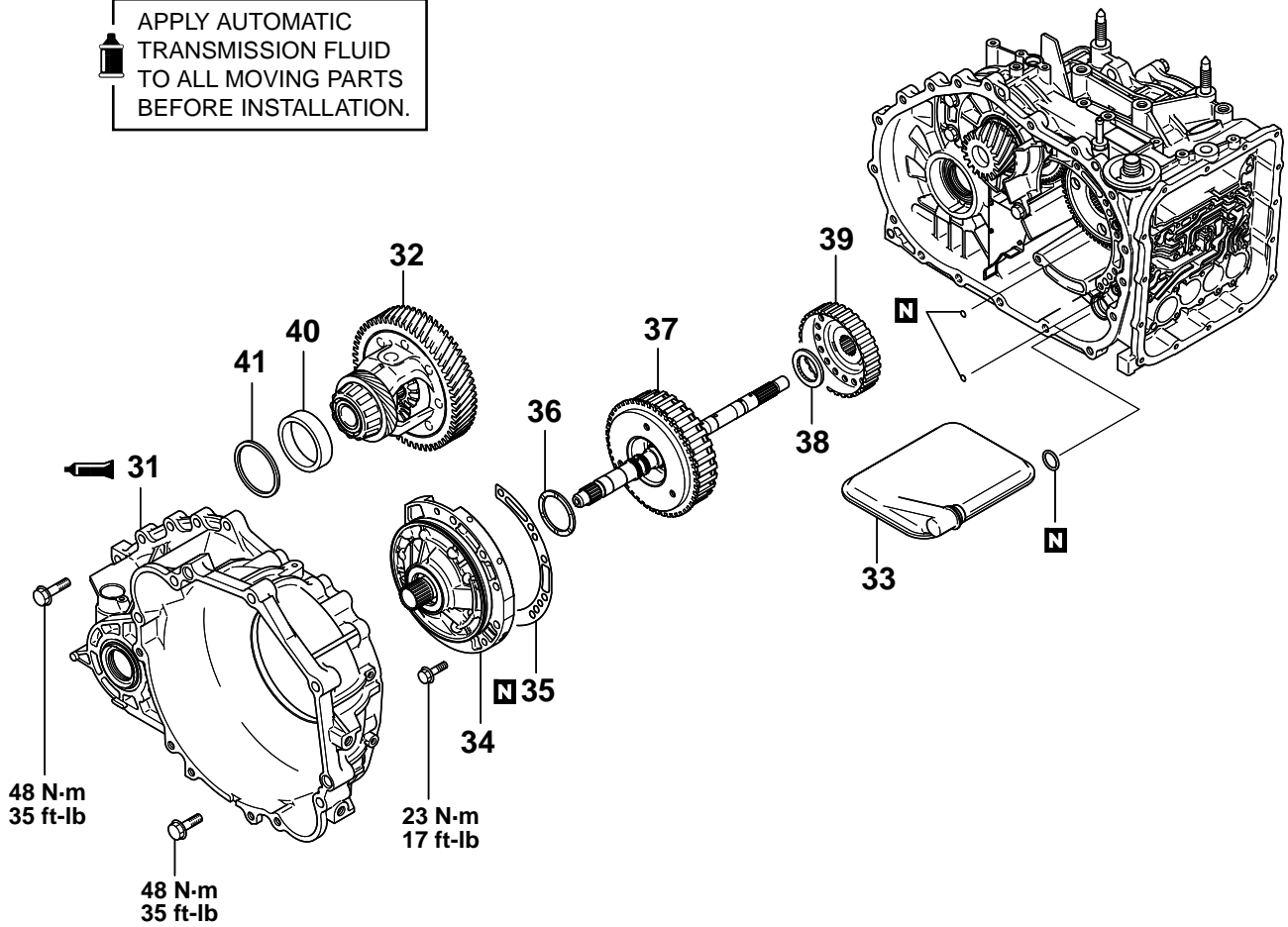

AKX01114AC

- 31. TORQUE CONVERTER HOUSING
- 32. DIFFERENTIAL
- 33. OIL FILTER
- 34. OIL PUMP
- 35. GASKET
- 36. THRUST WASHER NO.1

- 37. UNDERDRIVE CLUTCH AND INPUT SHAFT
- 38. THRUST BEARING NO.2
- 39. UNDERDRIVE CLUTCH HUB
- 40. OUTER RACE
- 41. SPACER



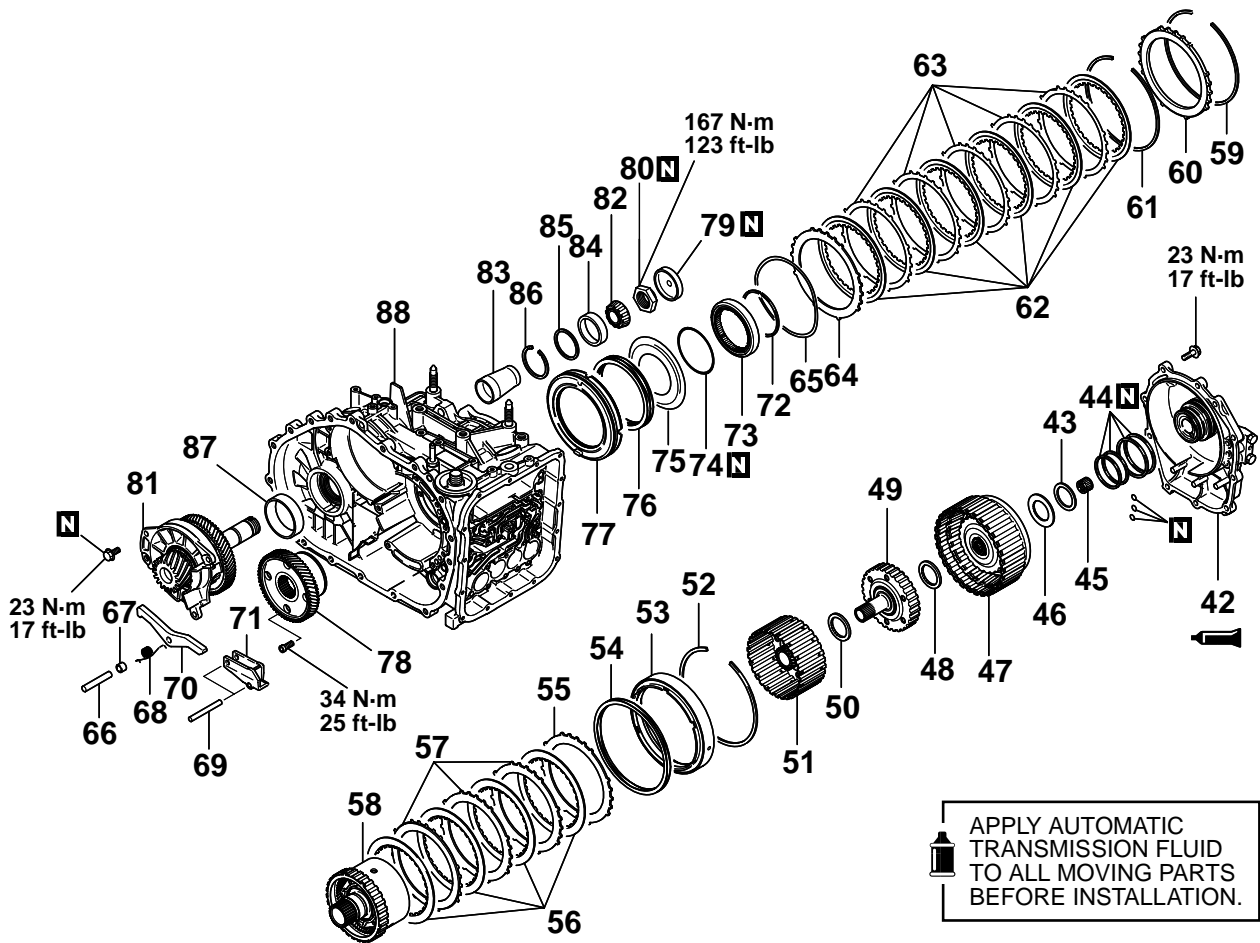

AKX01115AC

- |                                  |                                  |
|----------------------------------|----------------------------------|
| 42. REAR COVER                   | 66. PARKING PAWL SHAFT           |
| 43. THRUST RACE NO.8             | 67. SPACER                       |
| 44. SEAL RING                    | 68. PARKING PAWL SPRING          |
| 45. INPUT SHAFT REAR BEARING     | 69. PARKING ROLLER SUPPORT SHAFT |
| 46. THRUST BEARING NO.7          | 70. PARKING PAWL                 |
| 47. REVERSE AND OVERDRIVE CLUTCH | 71. PARKING ROLLER SUPPORT       |
| 48. THRUST BEARING NO.6          | 72. SNAP RING                    |
| 49. OVERDRIVE CLUTCH HUB         | 73. ONE-WAY CLUTCH INNER RACE    |
| 50. THRUST BEARING NO.5          | 74. O-RING                       |
| 51. PLANETARY REVERSE SUN GEAR   | 75. SPRING RETAINER              |
| 52. SNAP RING                    | 76. RETURN SPRING                |
| 53. SECOND BRAKE PISTON          | 77. LOW-REVERSE BRAKE PISTON     |
| 54. RETURN SPRING                | 78. TRANSFER DRIVE GEAR          |
| 55. PRESSURE PLATE               | 79. CAP                          |
| 56. SECOND BRAKE DISC            | 80. JAM NUT                      |
| 57. SECOND BRAKE PLATE           | 81. OUTPUT SHAFT                 |
| 58. PLANETARY CARRIER ASSEMBLY   | 82. TAPER ROLLER BEARING         |
| 59. SNAP RING                    | 83. COLLAR                       |
| 60. REACTION PLATE               | 84. OUTER RACE                   |
| 61. SNAP RING                    | 85. SPACER                       |
| 62. LOW-REVERSE BRAKE DISC       | 86. SNAP RING                    |
| 63. LOW-REVERSE BRAKE PLATE      | 87. OUTER RACE                   |
| 64. PRESSURE PLATE               | 88. TRANSAXLE CASE               |
| 65. WAVE SPRING                  |                                  |

<F4A51>

APPLY AUTOMATIC TRANSMISSION FLUID TO ALL MOVING PARTS BEFORE INSTALLATION.

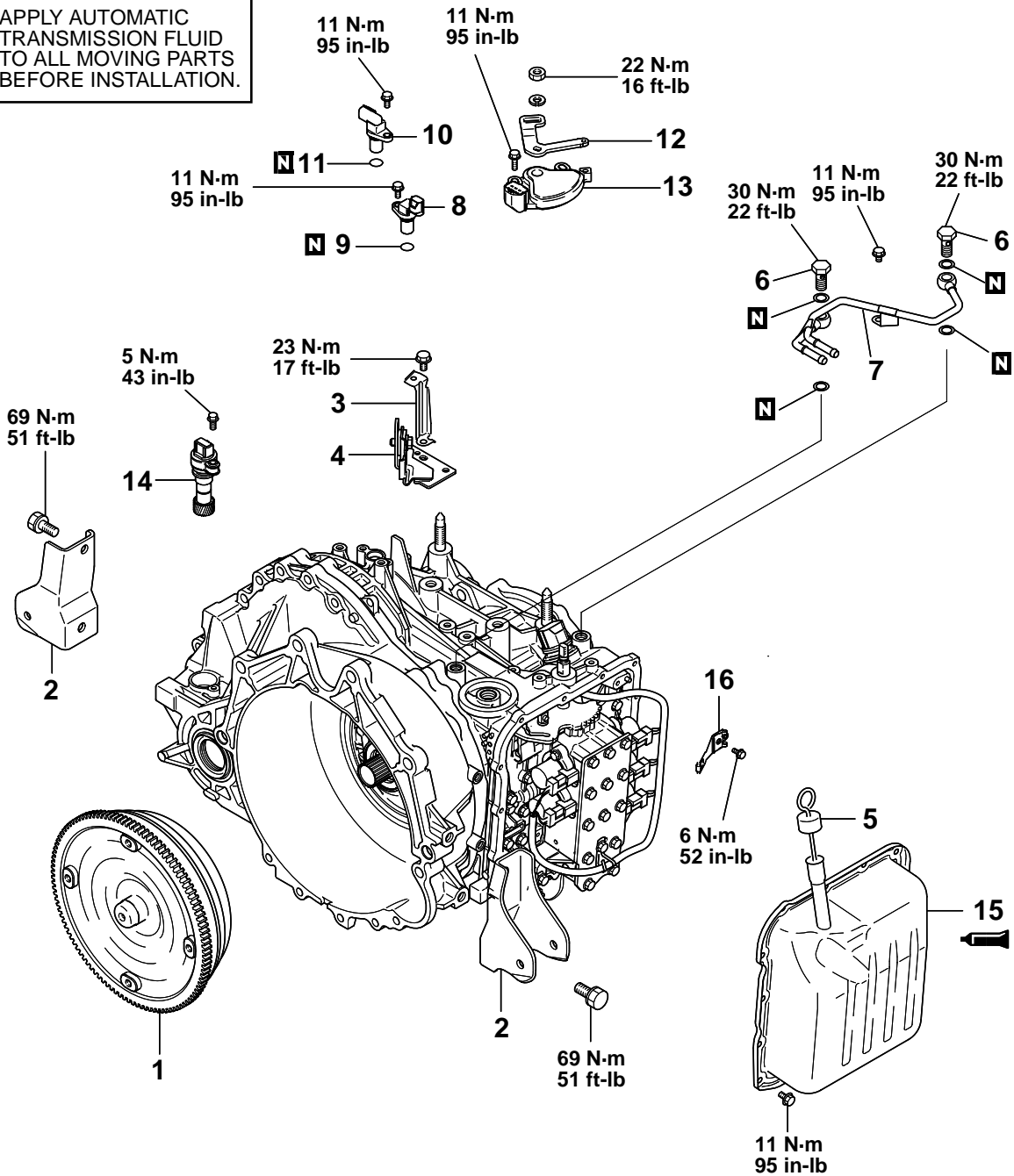

- 1. TORQUE CONVERTER
- 2. ROLL STOPPER BRACKET
- 3. HARNESS BRACKET
- 4. CONTROL CABLE SUPPORT BRACKET
- 5. OIL DIPSTICK
- 6. EYE BOLT
- 7. OIL COOLER FEED TUBE
- 8. INPUT SHAFT SPEED SENSOR

- 9. O-RING
- 10. OUTPUT SHAFT SPEED SENSOR
- 11. O-RING
- 12. MANUAL CONTROL LEVER
- 13. PARK/NEUTRAL POSITION SWITCH
- 14. SPEEDOMETER GEAR
- 15. VALVE BODY COVER
- 16. MANUAL CONTROL SHAFT DETENT

AKX01133AC

TSB Revision

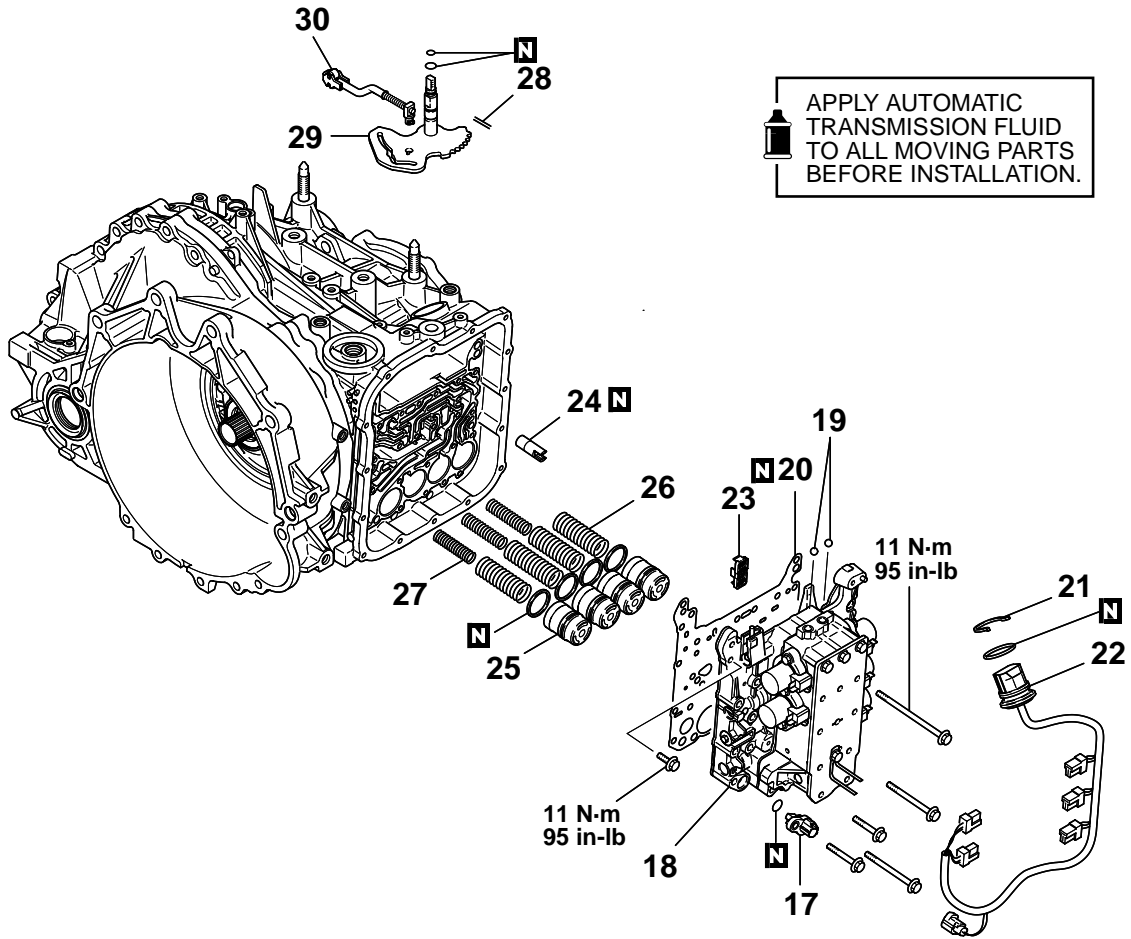

AKX01106AC

- |                                    |                                       |
|------------------------------------|---------------------------------------|
| 17. FLUID TEMPERATURE SENSOR       | 25. ACCUMULATOR PISTON                |
| 18. VALVE BODY                     | 26. ACCUMULATOR SPRING                |
| 19. STEEL BALL                     | 27. ACCUMULATOR SPRING                |
| 20. GASKET                         | 28. MANUAL CONTROL LEVER SHAFT ROLLER |
| 21. SNAP RING                      | 29. MANUAL CONTROL LEVER SHAFT        |
| 22. SOLENOID VALVE HARNESS         | 30. PARKING PAWL ROD                  |
| 23. STRAINER                       |                                       |
| 24. SECOND BRAKE RETAINER OIL SEAL |                                       |

 APPLY AUTOMATIC TRANSMISSION FLUID TO ALL MOVING PARTS BEFORE INSTALLATION.

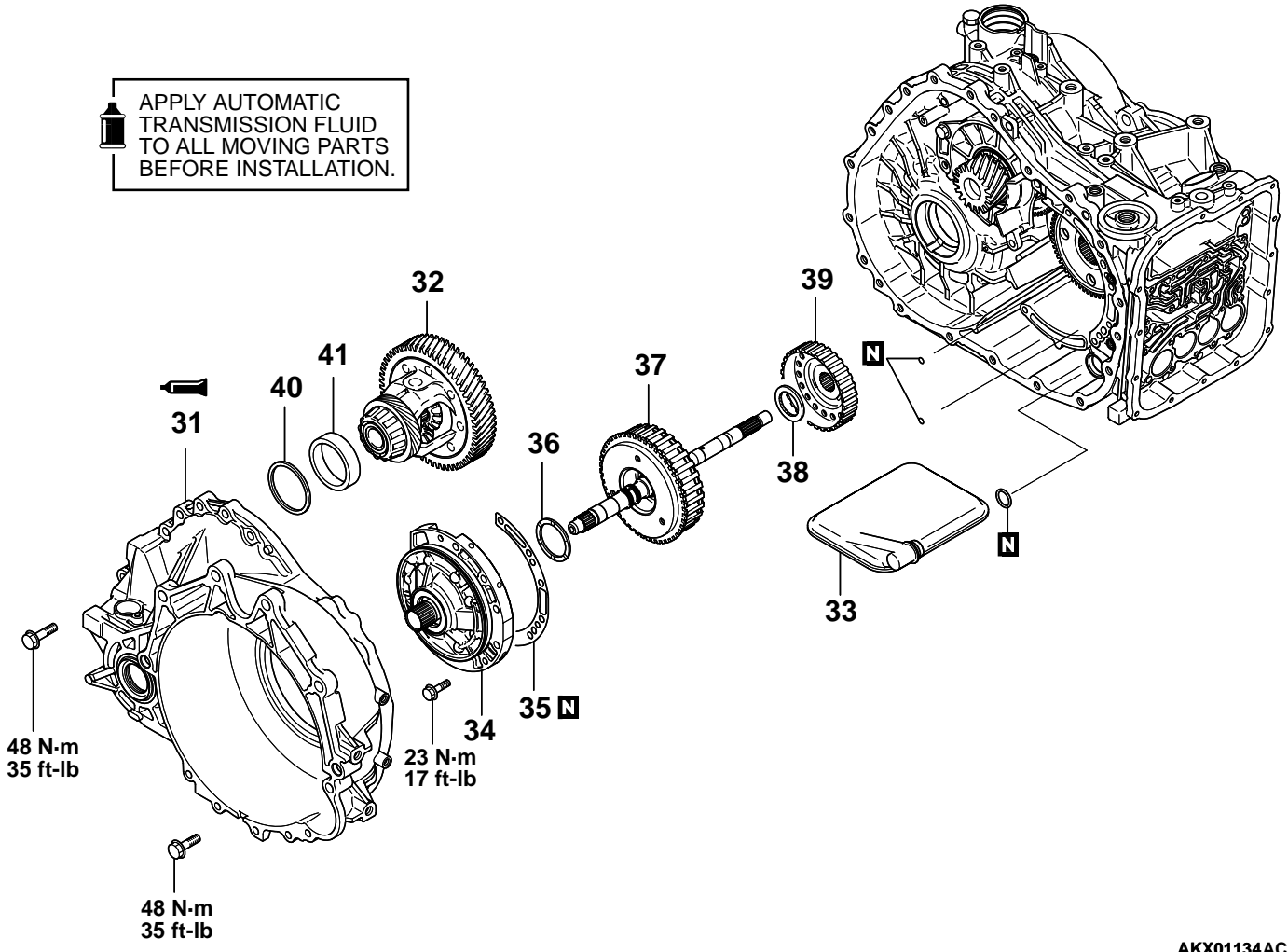

AKX01134AC

- 31. TORQUE CONVERTER HOUSING
- 32. DIFFERENTIAL
- 33. OIL FILTER
- 34. OIL PUMP
- 35. GASKET
- 36. THRUST WASHER NO.1

- 37. UNDERDRIVE CLUTCH AND INPUT SHAFT
- 38. THRUST BEARING NO.2
- 39. UNDERDRIVE CLUTCH HUB
- 40. OUTER RACE
- 41. SPACER

TSB Revision

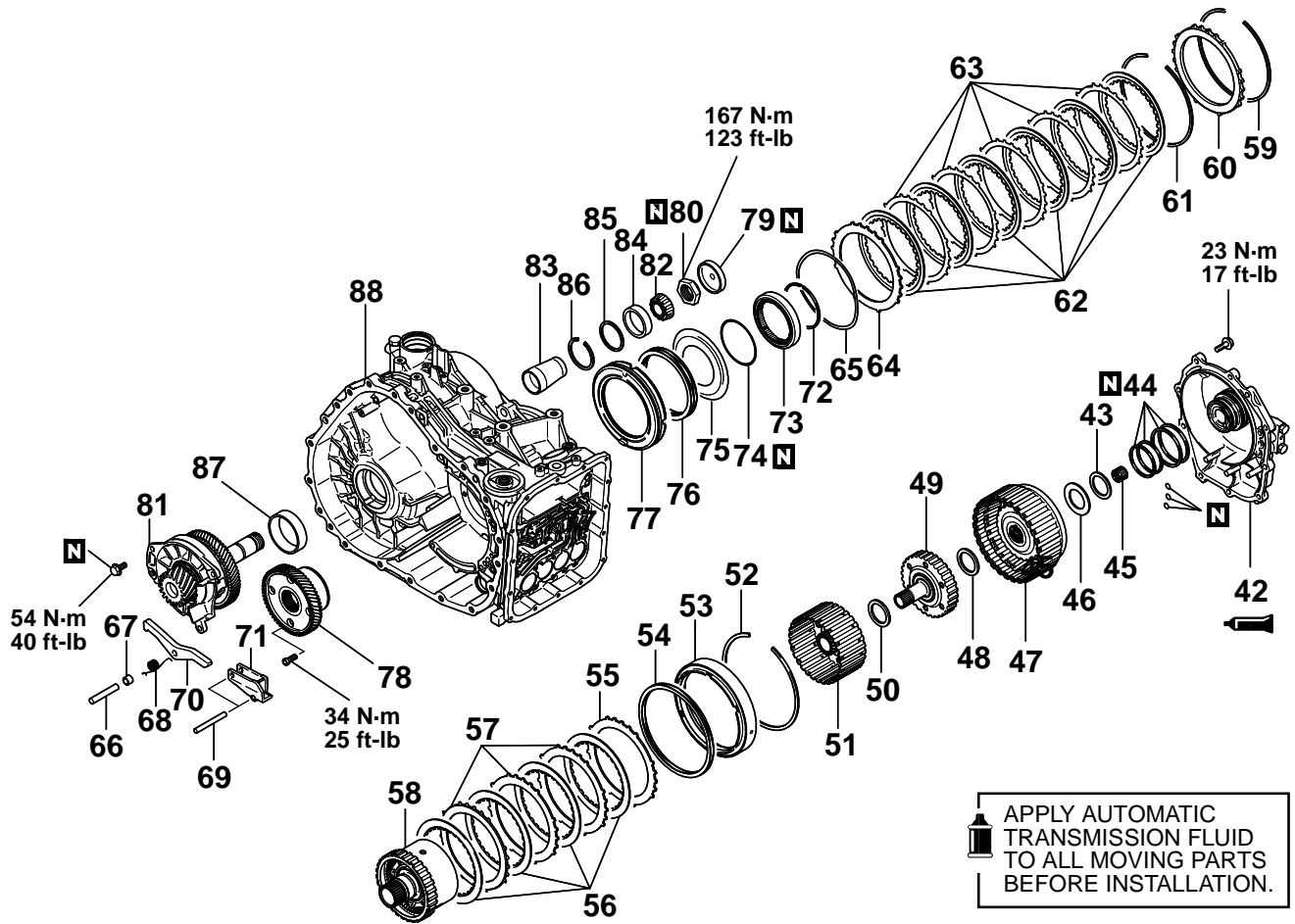

AKX01135AC

- |                                |                                  |
|--------------------------------|----------------------------------|
| 42. REAR COVER                 | 66. PARKING PAWL SHAFT           |
| 43. THRUST RACE NO.8           | 67. SPACER                       |
| 44. SEAL RING                  | 68. PARKING PAWL SPRING          |
| 45. INPUT SHAFT REAR BEARING   | 69. PARKING ROLLER SUPPORT SHAFT |
| 46. THRUST BEARING NO.7        | 70. PARKING PAWL                 |
| 47. REAR AND OVERDRIVE CLUTCH  | 71. PARKING ROLLER SUPPORT       |
| 48. THRUST BEARING NO.6        | 72. SNAP RING                    |
| 49. OVERDRIVE CLUTCH HUB       | 73. ONE-WAY CLUTCH INNER RACE    |
| 50. THRUST BEARING NO.5        | 74. O-RING                       |
| 51. PLANETARY REVERSE SUN GEAR | 75. SPRING RETAINER              |
| 52. SNAP RING                  | 76. RETURN SPRING                |
| 53. SECOND BRAKE PISTON        | 77. LOW-REVERSE BRAKE PISTON     |
| 54. RETURN SPRING              | 78. TRANSFER DRIVE GEAR          |
| 55. PRESSURE PLATE             | 79. CAP                          |
| 56. SECOND BRAKE DISC          | 80. JAM NUT                      |
| 57. SECOND BRAKE PLATE         | 81. OUTPUT SHAFT                 |
| 58. PLANETARY CARRIER ASSEMBLY | 82. TAPER ROLLER BEARING         |
| 59. SNAP RING                  | 83. COLLAR                       |
| 60. REACTION PLATE             | 84. OUTER RACE                   |
| 61. SNAP RING                  | 85. SPACER                       |
| 62. LOW-REVERSE BRAKE DISC     | 86. SNAP RING                    |
| 63. LOW-REVERSE BRAKE PLATE    | 87. OUTER RACE                   |
| 64. PRESSURE PLATE             | 88. TRANSAXLE CASE               |
| 65. WAVE SPRING                |                                  |

## DISASSEMBLY

**⚠ CAUTION**

- Because the automatic transaxle is manufactured from high-precision parts, care must be taken not to scratch or damage these parts during disassembly and assembly.
- The working area should be covered with a rubber mat to keep it clean at all times.
- Do not wear any cloth gloves and do not use any shop towels during disassembly. Use only nylon cloth, paper towels or any other lint-free material.
- Parts which have been disassembled should all be cleaned. Metal parts can be cleaned with normal detergent, but they should be dried completely using compressed air.
- Clutch discs, plastic thrust plates and rubber parts should be cleaned with automatic transmission fluid (ATF).
- If the transaxle body has been damaged, disassemble and clean the cooler system.

1. Remove the torque converter.
2. Remove each bracket.
3. Remove the dipstick.
4. Remove the eye bolt gauge, gaskets and the oil cooler feed tube.
5. Remove the input shaft speed sensor and output shaft speed sensor.

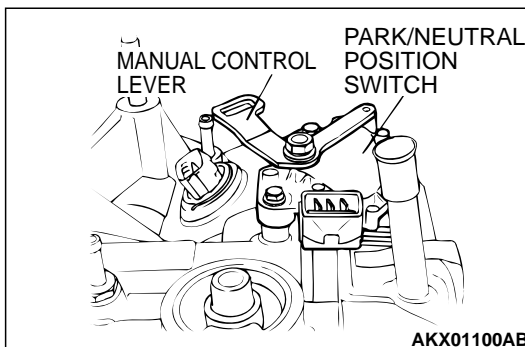
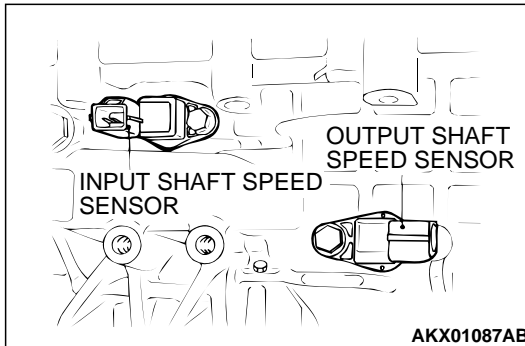
**⚠ CAUTION**

The manual control lever tightening nut must be removed before removing the valve body. If the valve body is removed before the nut, the park/neutral position switch will be damaged.

6. Loosen the manual control lever tightening nut, and then remove the manual control lever, and the park/neutral position switch.

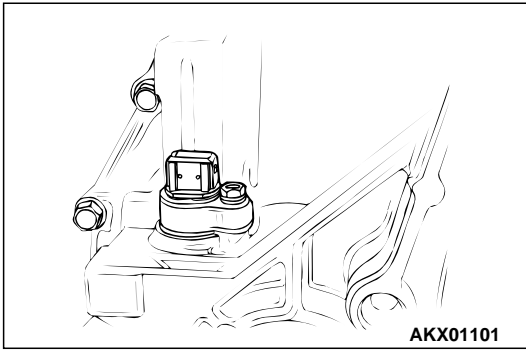

7. Remove the speedometer gear.

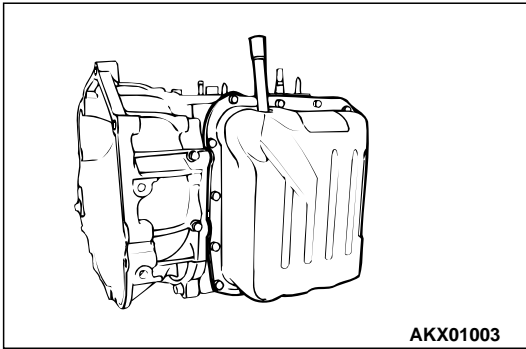

8. Remove the valve body cover.

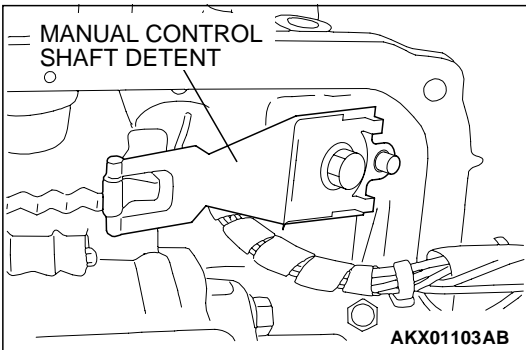

9. Remove the manual control shaft detent.

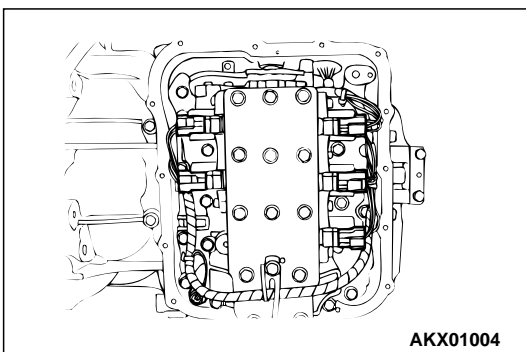

10. Disconnect the harness connectors from the solenoid valves and the fluid temperature sensor of the valve body.

**⚠ CAUTION**

Make sure that the manual control lever and the park/neutral position switch are removed. See step 8.

11. Remove the valve body mounting bolts (28 pieces).
12. Remove the fluid temperature sensor.

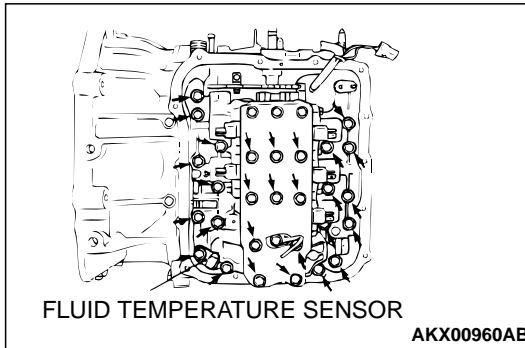
**⚠ CAUTION**

Do not lose the two steel balls.

13. Remove the valve body, gasket and the two steel balls.

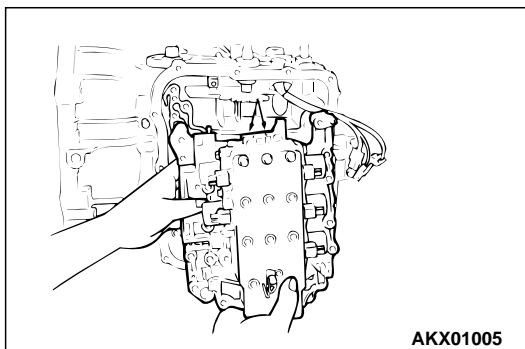

14. Remove the snap ring from the connector and then push the connector into the transaxle case and remove the solenoid valve harness.

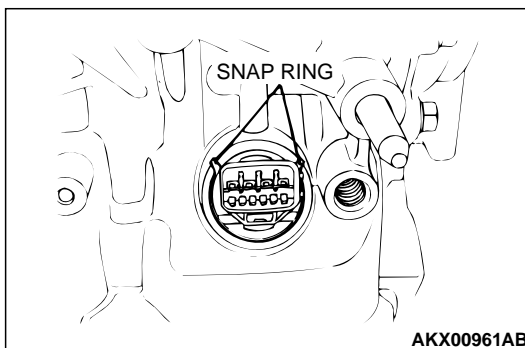

15. Remove the strainer and the second brake retainer oil seal.

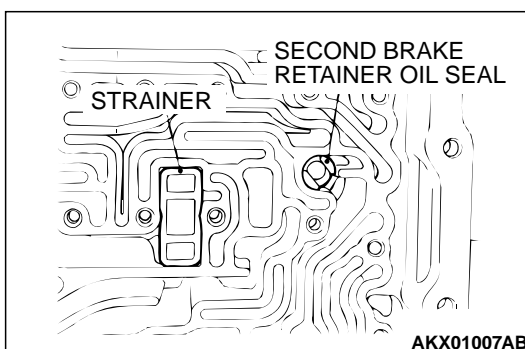



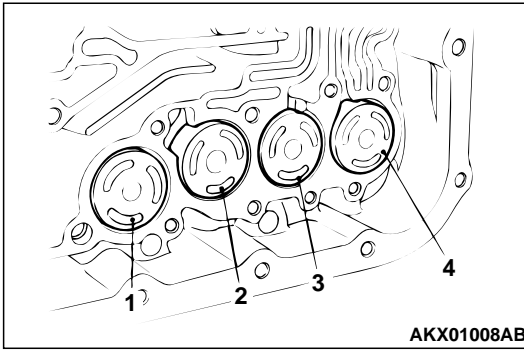

16. Remove each accumulator piston and spring.

NUMBER	NAME
1	For low-reverse brake
2	For underdrive clutch
3	For second brake
4	For overdrive clutch

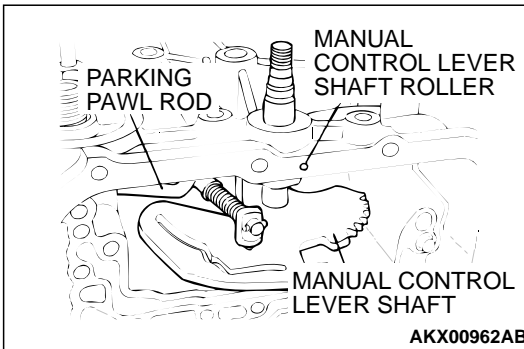

17. Remove the manual control lever shaft roller.

18. Remove the manual control lever shaft and the parking pawl rod.

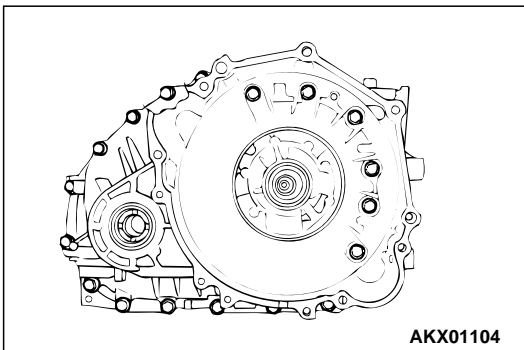

19. Remove the torque converter housing mounting bolts (18 pieces), and then remove the torque converter housing.

20. Remove the differential bearing outer race and spacer from the torque converter housing.

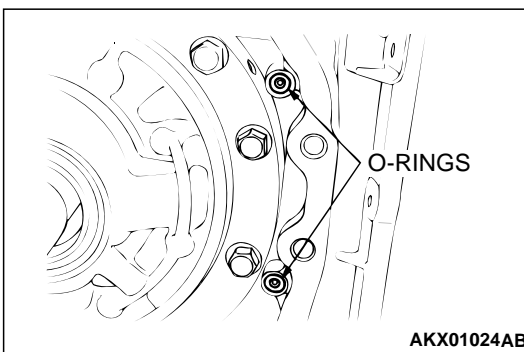

21. Remove the O-rings (two pieces).

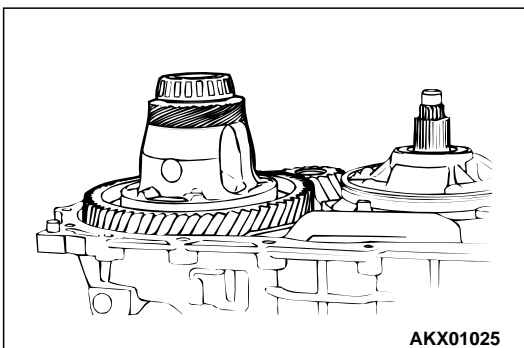

22. Remove the differential.

23. Remove the differential bearing outer race from the transaxle case.

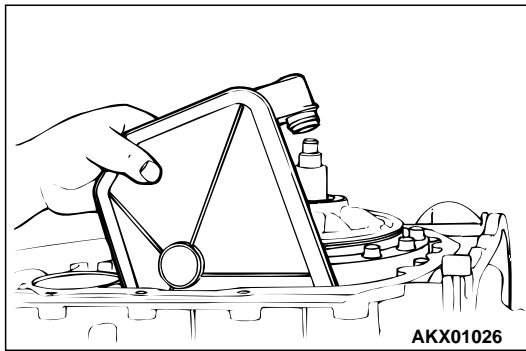

24. Remove the oil filter.

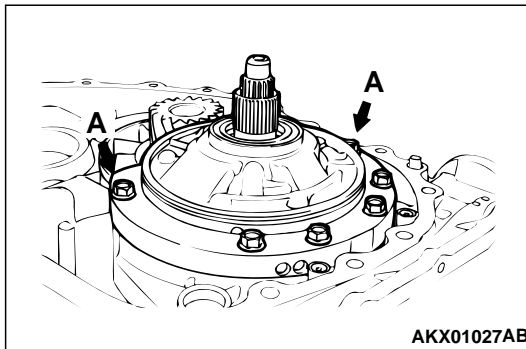

25. Remove the oil pump mounting bolts (six pieces).  
26. Install special tool MD998333 in hole "A."

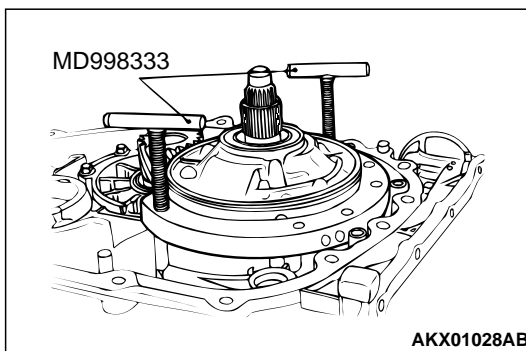

27. Turn special tools MD998333 to remove the oil pump.  
28. Remove the oil pump gasket.

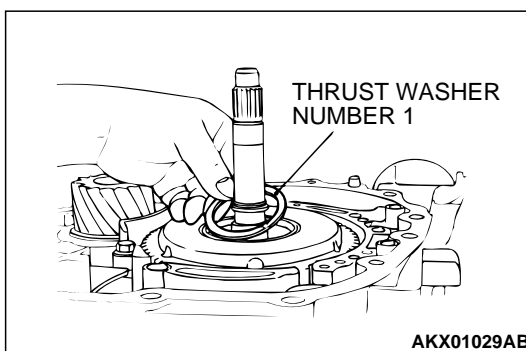

29. Remove thrust washer number 1.

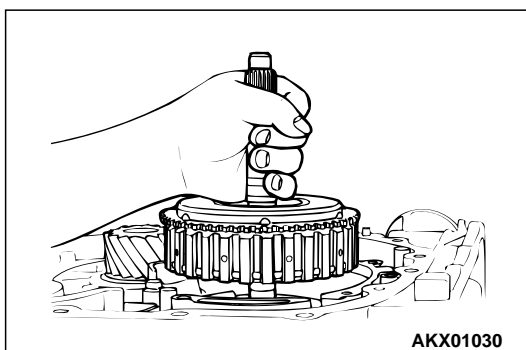

30. Holding the input shaft, remove the underdrive clutch and input shaft.

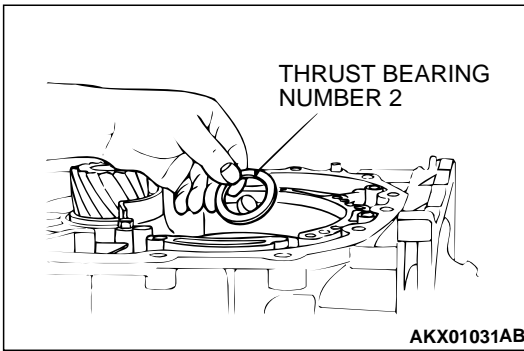

31.Remove thrust bearing number 2.

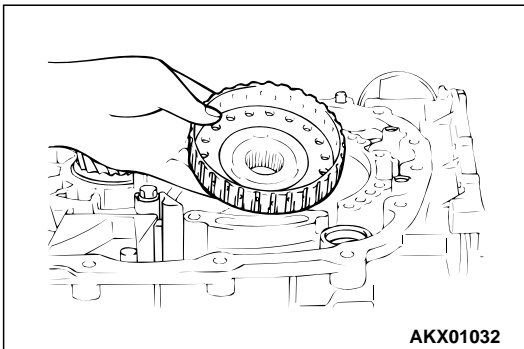

32.Remove the underdrive clutch hub.

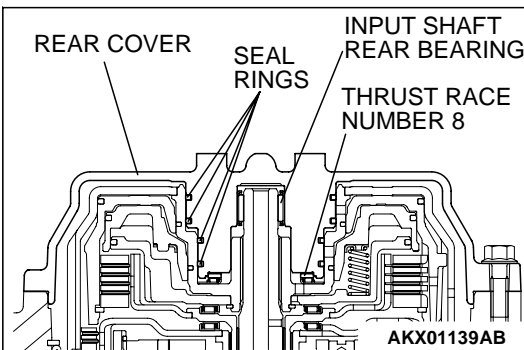

33.Remove the rear cover.

34.Remove thrust race number 8.

35.Remove the seal rings (four pieces).

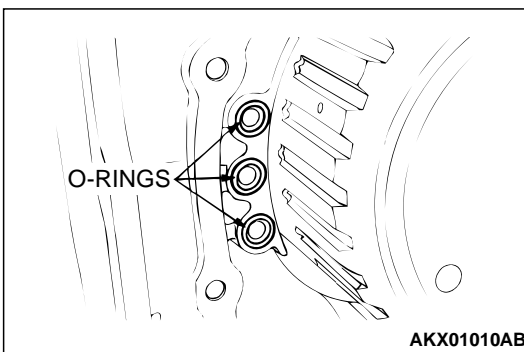

36.Remove the O-rings (three pieces).

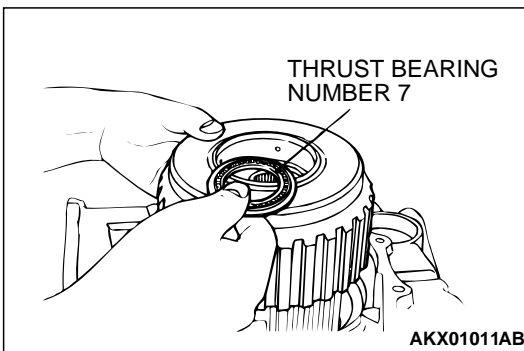

37.Remove the reverse and overdrive clutch and thrust bearing number 7.

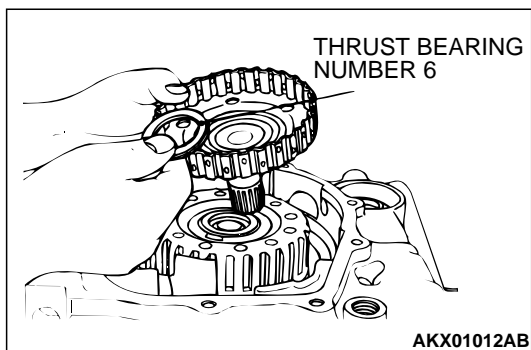

38. Remove overdrive clutch hub and thrust bearing number 6.

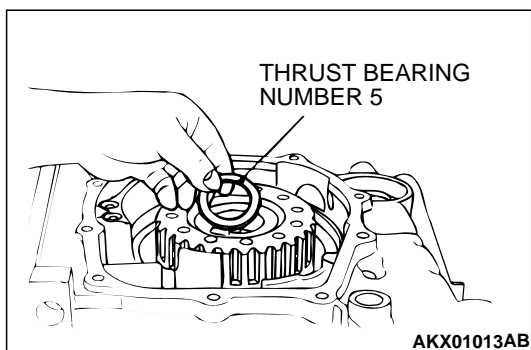

39. Remove thrust bearing number 5.

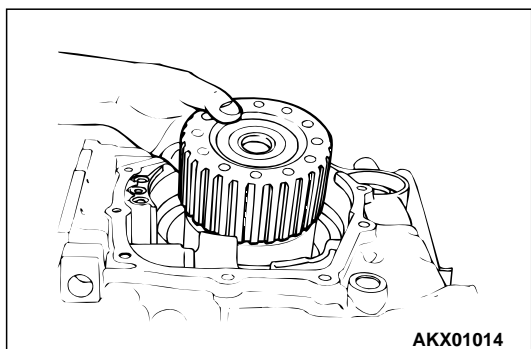

40. Remove the planetary reverse sun gear.

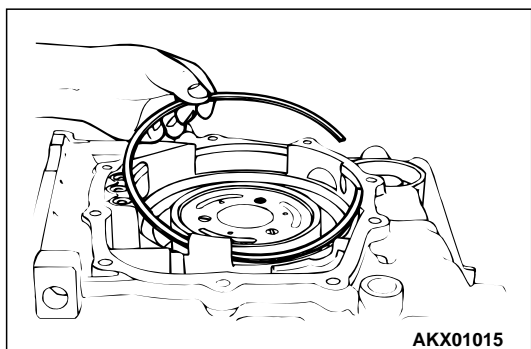

41. Remove the snap ring.

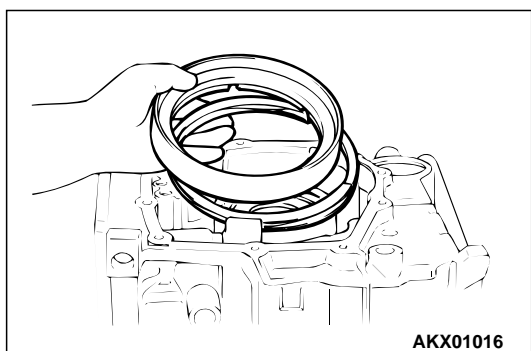

42. Remove the second brake piston and the return spring.

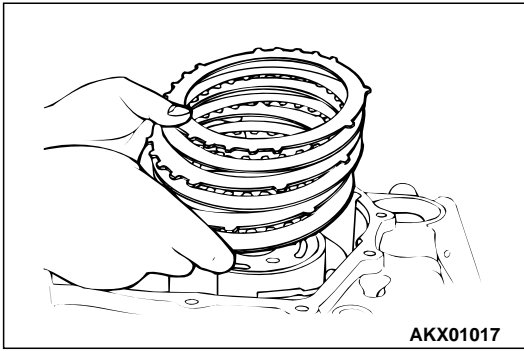

43. Remove the pressure plate, brake discs and brake plate.

**Number of brake discs and plates:**

A/T MODEL	BRAKE DISC	BRAKE PLATE	PRESSURE PLATE
F4A42	3	2	1
F4A51	4	3	1

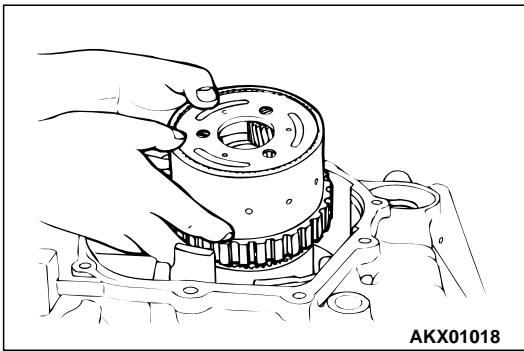

44. Remove the planetary carrier assembly.

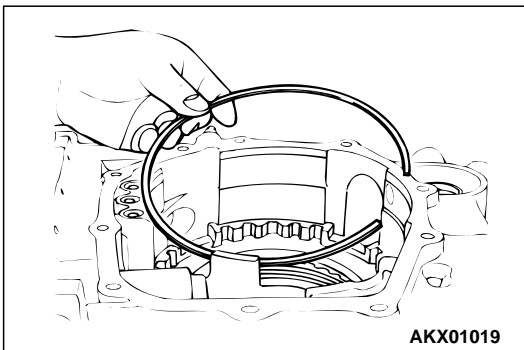

45. Remove the snap ring.

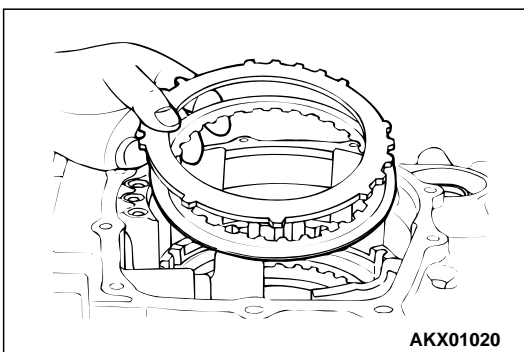

46. Remove the reaction plate and the brake disc.

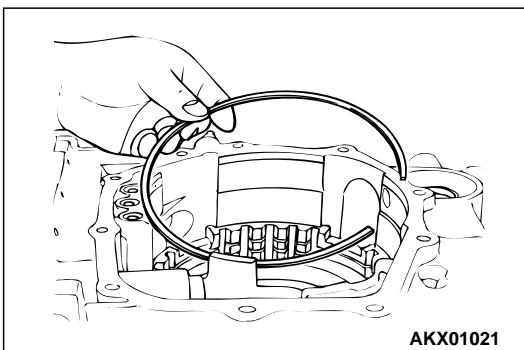

47. Remove the snap ring.

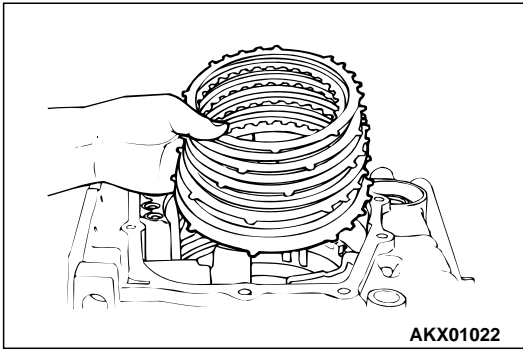

48. Remove the brake plates (five pieces), brake discs (six pieces) and pressure plate.

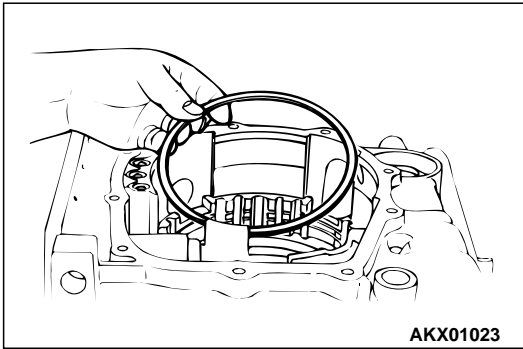

49. Remove the wave spring.

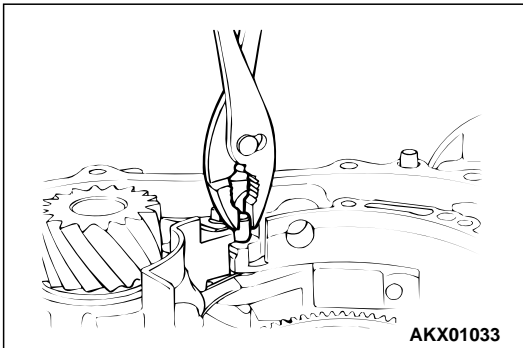

50. Remove the parking pawl shaft, and then remove the spacer and spring.

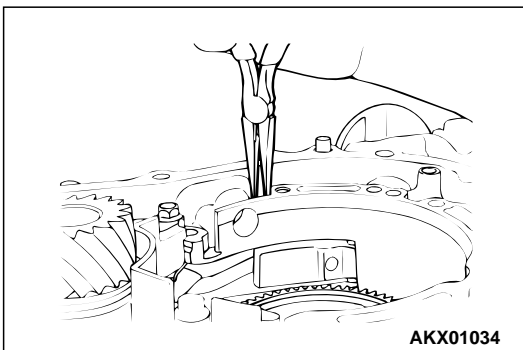

51. Remove the two parking roller support shafts, and then remove the parking roller support.

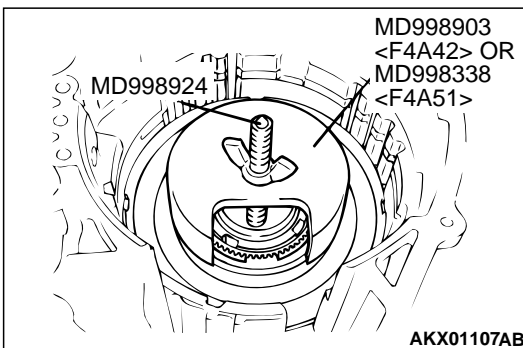

52. Remove the one-way clutch inner race and low-reverse brake piston as follows:

- (1) Using special tools MD998903 <F4A42> or MD998338 <F4A51> and MD998924, compress the one-way clutch inner race.

*NOTE: This illustration shows F4A51.*

- (2) Remove the snap ring.
- (3) Remove the special tools.
- (4) Remove the one-way clutch inner race, O-ring, spring retainer, return spring and low-reverse brake piston.

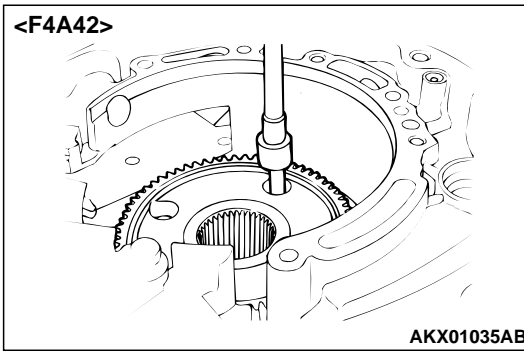

53. Remove the four <F4A51> or three <F4A42> transfer drive gear bearing mounting bolts. Then, turn the gear 1/8 turn (45 degree angle) and remove the remaining bolts.  
F4A42 = seven mounting bolts  
F4A51 = eight mounting bolts

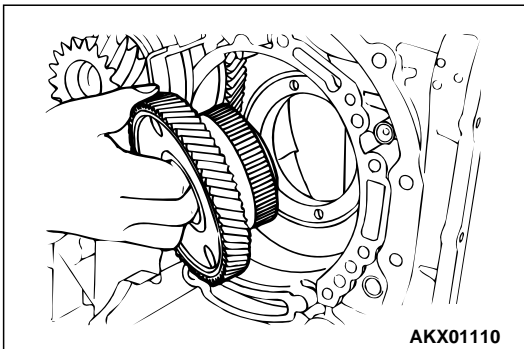

54. Remove the transfer drive gear.

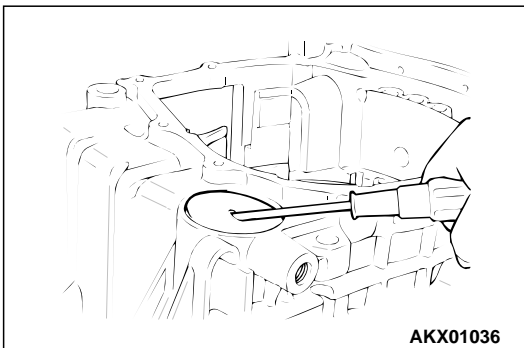

55. Remove the cap.

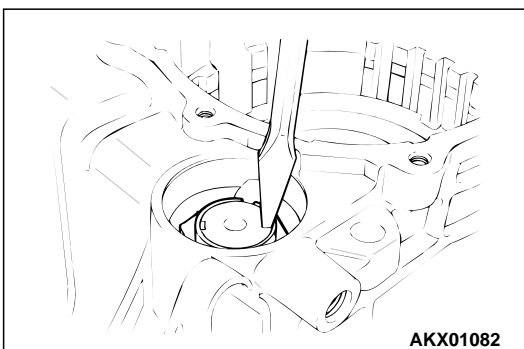

56. Using a chisel, remove the staked nut from the output shaft.

**⚠ CAUTION**

The jam nut is reverse threaded.

57. Use special tools MB991625 and MB990607 to remove the output shaft jam nut.

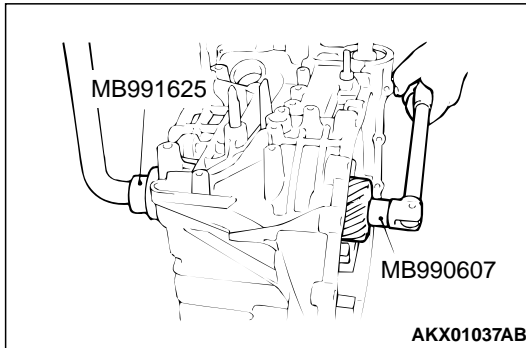

58. Remove the bearing retainer mounting bolt.

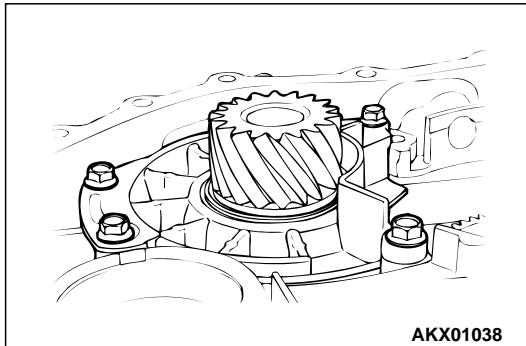

59. Tap on the rear end of the output shaft to remove the output shaft, taper roller bearing and collar.

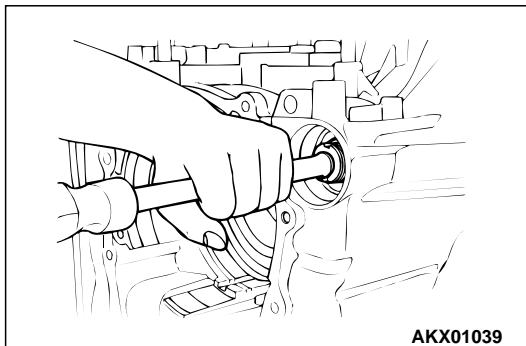

60. Remove the outer race and the spacer.

61. Remove the snap ring.

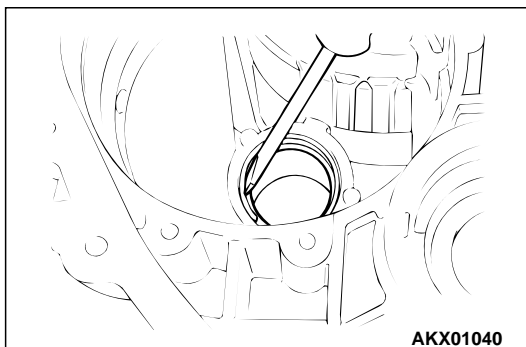



## ASSEMBLY

### CAUTION

- Do not reuse the gasket, O-ring, oil seal. Always replace with a new one when assembling.
  - Do not use grease other than petroleum jelly (Vaseline).
  - Apply ATF to friction components, rotating parts, and sliding parts before installation. Immerse a new clutch disc or brake disc in ATF for at least two hours before assembling them.
  - When replacing a bushing, replace the assembly which it belongs to.
  - Do not use cloth gloves or shop towels during assembly. Use nylon cloth or other lint-free material.
1. Install special tool MD998412 in the installation screw hole of the transfer drive gear bearing located in the transaxle case. Using this as a guide, install the transfer drive gear bearing and gear in the transaxle case.

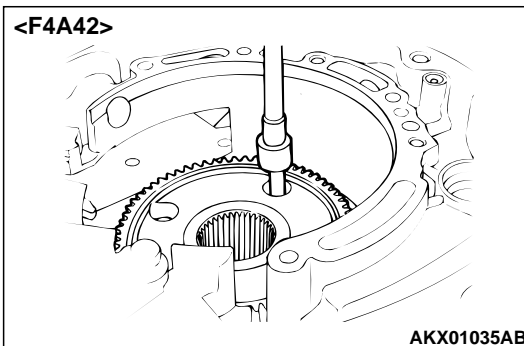
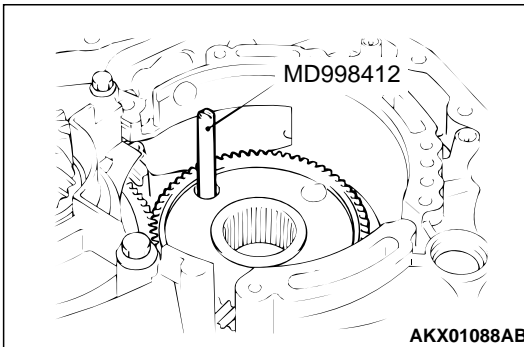

2. Tighten the seven mounting bolts (F4A42) and eight mounting bolts (F4A51) of the transfer drive gear bearing to the specified torque.

**Tightening torque: 34 N·m (25 ft-lb)**

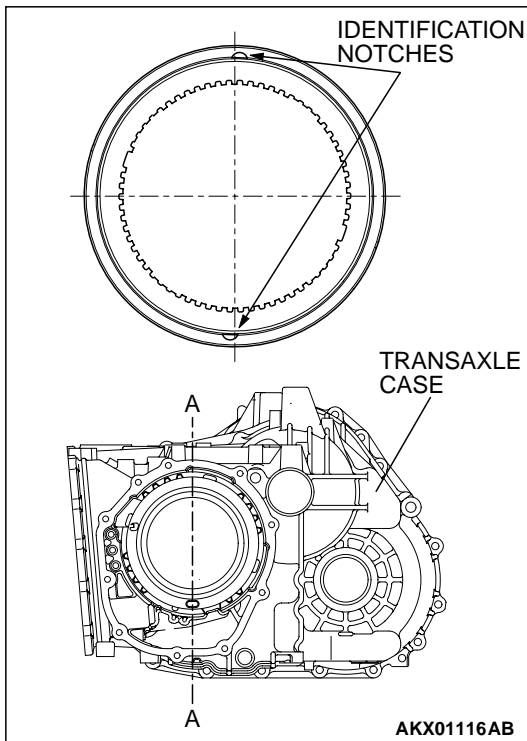

3. Install the low-reverse brake piston, return spring, and spring retainer into the transaxle case.
4. Fit a new O-ring into the groove of one-way clutch inner race.
5. Check the placement of the identification notches in the one-way clutch inner race. Install the one-way clutch inner race to the transfer drive gear bearing so that the notches fall along the A – A line.

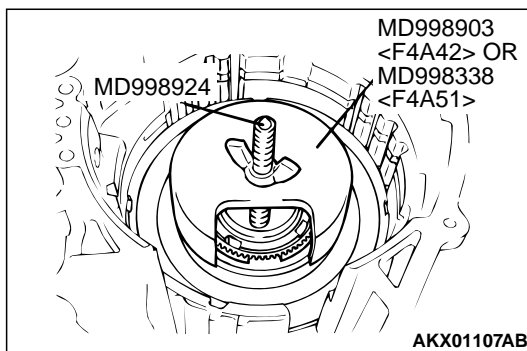

6. Put the snap ring on the inner race.
7. Set special tools MD998703 <F4A42> or MD998338 <F4A51> and MD998924 as shown, and then compress the one-way clutch inner race and install the snap ring.  
*NOTE: This illustration shows F4A51.*

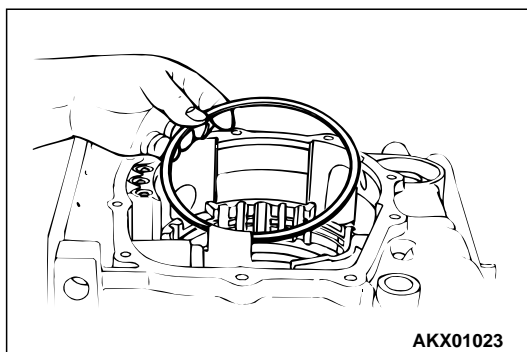

8. Install the wave spring onto the low-reverse brake piston.

**⚠ CAUTION**

If necessary, take the measurements in steps 9 to 18 after replacing the pressure plate, brake plate and brake disc.

9. Install the six brake discs, five brake plates and snap ring as shown in the figure.

*NOTE: Do not install the pressure plate at this time.*

10. Install special tool MB991631 <F4A42> or MB991632 <F4A51> on the brake disc.

11. Install the reaction plate and the used snap ring.

12. Move special tool MB991631 <F4A42> or MB991632 <F4A51> to measure the end play of reaction plate. Then replace the snap ring installed in step 11 to adjust the end play to standard value.

**Standard value: 0 – 0.16 mm (0 – 0.0063 inch)**

13. Install the brake discs and brake plates as shown in the figure.

**Number of brake discs and plates**

A/T MODEL	BRAKE DISC	BRAKE PLATE
F4A42	3	2
F4A51	4	3

14. Place special tool MB991631 <F4A42> or MB991632 <F4A51> on top of the brake disc in place of the pressure plate.

15. Install the return spring, second brake piston and snap ring.

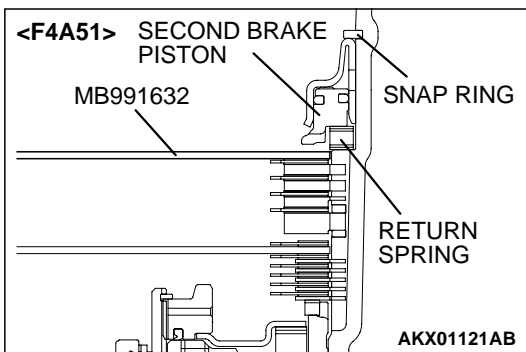
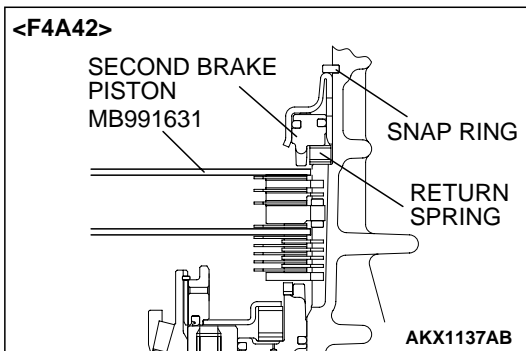
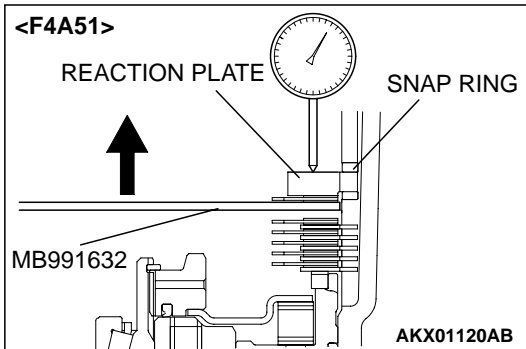
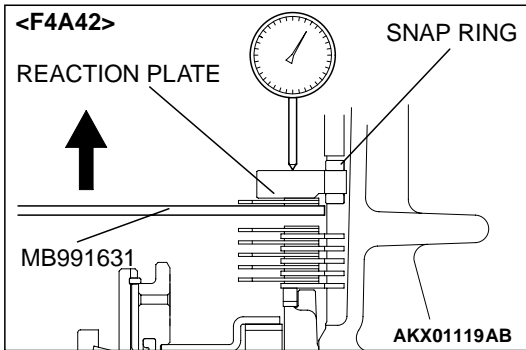

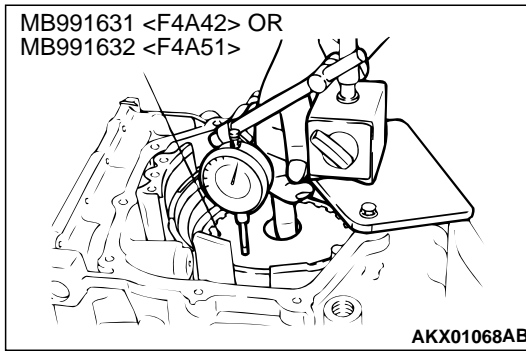

16. Move special tool MB991631 <F4A42> or MB991632 <F4A51> and measure its movement.

**Standard value of end play (Reference):**

**0.79 – 1.25 mm (0.0311 – 0.0492 inch) <F4A42>**

**1.09 – 1.55 mm (0.0429 – 0.0610 inch) <F4A51>**

17. Select a pressure plate whose thickness corresponds to the measured amount of movement from the following table.

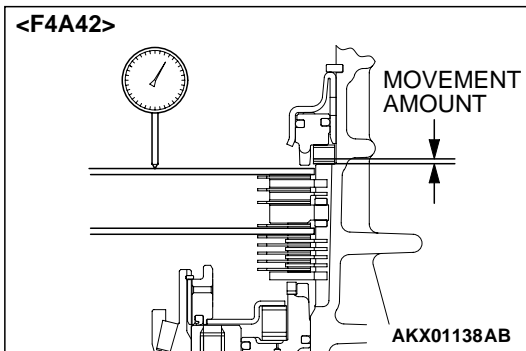

**PRESSURE PLATE FOR F4A42**

MOVEMENT AMOUNT mm (in)	THICKNESS mm (in)	ID SYMBOL	PRESSURE PLATE PART NO.
0.6 – 0.8 (0.024 – 0.031)	1.6 (0.063)	L	MD759567
0.8 – 1.0 (0.031 – 0.039)	1.8 (0.071)	1	MD759414
1.0 – 1.2 (0.039 – 0.047)	2.0 (0.079)	0	MD759415
1.2 – 1.4 (0.047 – 0.055)	2.2 (0.087)	2	MD759416
1.4 – 1.6 (0.055 – 0.063)	2.4 (0.094)	4	MD759417
1.6 – 1.8 (0.063 – 0.071)	2.6 (0.102)	6	MD759418

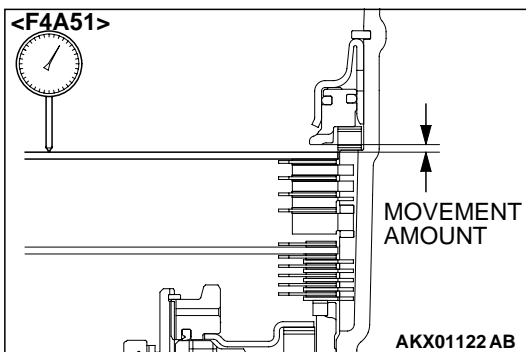

**PRESSURE PLATE FOR F4A51**

MOVEMENT AMOUNT mm (in)	THICKNESS mm (in)	ID SYMBOL	PRESSURE PLATE PART NO.
1.1 – 1.3 (0.043 – 0.051)	1.8 (0.071)	E	MD759425
1.3 – 1.5 (0.051 – 0.059)	2.0 (0.079)	D	MD759426
1.5 – 1.7 (0.059 – 0.067)	2.2 (0.087)	C	MD759427
1.7 – 1.9 (0.067 – 0.075)	2.4 (0.094)	B	MD759428
1.9 – 2.1 (0.075 – 0.083)	2.6 (0.102)	A	MD759429
2.1 – 2.3 (0.083 – 0.091)	2.8 (0.110)	0	MD759430

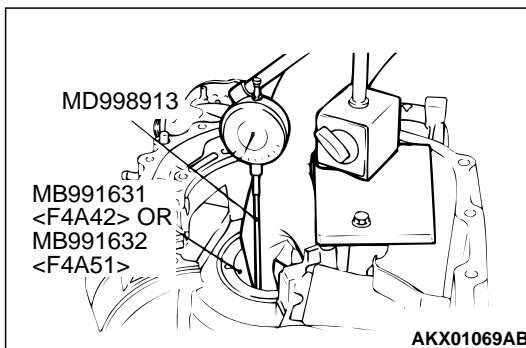

18. Turn the transaxle over so that the installation surface of the torque converter housing is facing up.

Install special tool MD998913 in a dial gauge, and then move special tool MB991631 <F4A42> or MB991632 <F4A51> and measure its movement.

**Standard value of end play (Reference):**  
**1.65 – 2.11 mm (0.050 – 0.0831 inch)**

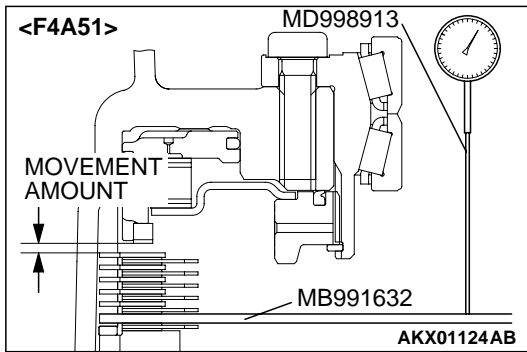
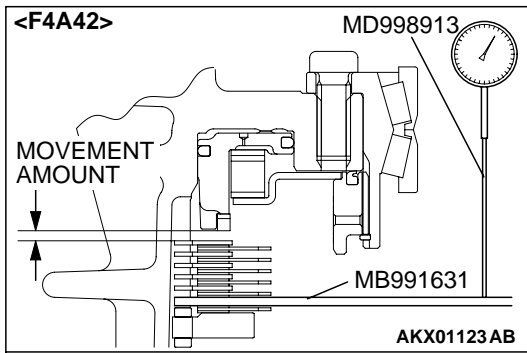

19. Select a pressure plate whose thickness corresponds to the measured amount of movement from the table below.

*NOTE: This illustration shows F4A51.*

**PRESSURE PLATE FOR F4A42**

MOVEMENT AMOUNT mm (in)	THICKNESS mm (in)	ID SYMBOL	PRESSURE PLATE PART NO.
1.3 – 1.5 (0.051 – 0.059)	1.6 (0.063)	L	MD759567
1.5 – 1.7 (0.059 – 0.067)	1.8 (0.071)	1	MD759414
1.7 – 1.9 (0.067 – 0.075)	2.0 (0.079)	0	MD759415
1.9 – 2.1 (0.075 – 0.083)	2.2 (0.087)	2	MD759416
2.1 – 2.3 (0.083 – 0.091)	2.4 (0.094)	4	MD759417
2.3 – 2.5 (0.091 – 0.098)	2.6 (0.102)	6	MD759418
2.5 – 2.7 (0.098 – 0.106)	2.8 (0.110)	8	MD759419
2.7 – 2.9 (0.106 – 0.114)	3.0 (0.118)	D	MD759420

**PRESSURE PLATE FOR F4A51**

MOVEMENT AMOUNT mm (in)	THICKNESS mm (in)	ID SYMBOL	PRESSURE PLATE PART NO.
1.0 – 1.2 (0.039 – 0.047)	1.6 (0.063)	F	MD759568
1.2 – 1.4 (0.047 – 0.055)	1.8 (0.071)	E	MD759425
1.4 – 1.6 (0.055 – 0.063)	2.0 (0.079)	D	MD759426
1.6 – 1.8 (0.063 – 0.071)	2.2 (0.087)	C	MD759427
1.8 – 2.0 (0.071 – 0.079)	2.4 (0.094)	B	MD759428
2.0 – 2.2 (0.079 – 0.087)	2.6 (0.102)	A	MD759429
2.2 – 2.4 (0.087 – 0.094)	2.8 (0.110)	0	MD759430
2.4 – 2.6 (0.094 – 0.102)	3.0 (0.118)	1	MD759431

20. Remove all parts and special tools that were installed to take the measurements in steps 8 to 18. Remove and separate the pressure plate and snap ring chosen in steps 12, 16 and 18.

21. Install the snap ring into the groove of transaxle case output shaft bore.

22. Install the thinnest output shaft preload adjustment spacer [thickness 1.88 mm (0.0740 in); part number MD756579].

23. Use special tools MB990930 and MB990938 to tap the output shaft bearing outer race in the transaxle case.

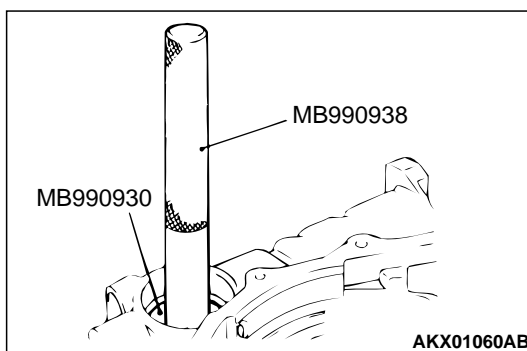

**⚠ CAUTION**

**Do not reuse the bolt, as it has had sealant applied.**

24. Tighten the mounting bolts of the output shaft bearing retainer to the specified torque.

**Tightening torque:**

**23 N·m(17 ft-lb) <F4A42>**

**54 N·m(40 ft-lb) <F4A51>**

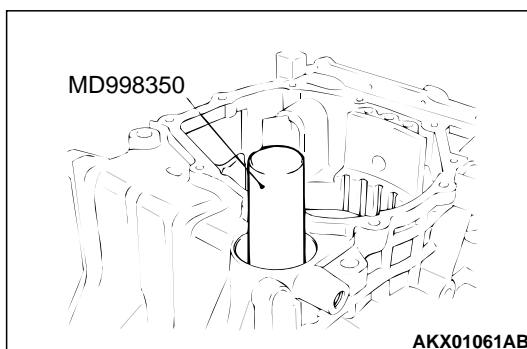
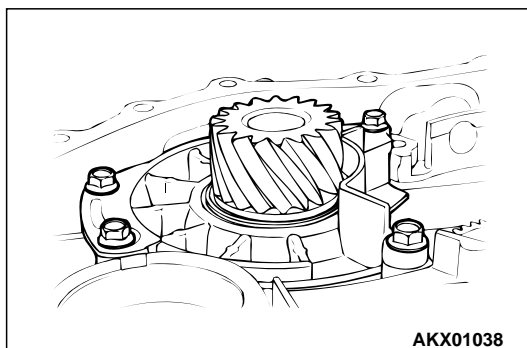

25. Use special tool MD998350 to install the collar and taper roller bearing on the output shaft.

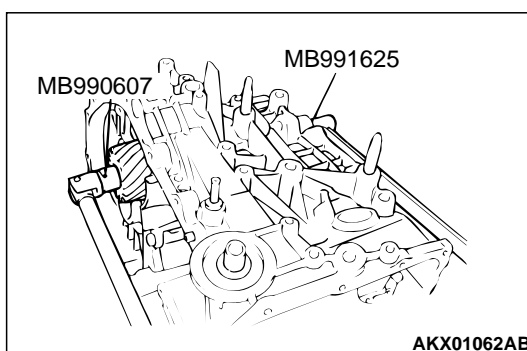

26. Apply ATF to a new jam nut, and use special tools MB990607 and MB991625 to tighten the jam nut to the specified torque. Then turn back one turn, and tighten to the specified torque again.

**Tightening torque: 167 N·m (123 ft-lb)**

*NOTE: The jam nut is reverse threaded.*

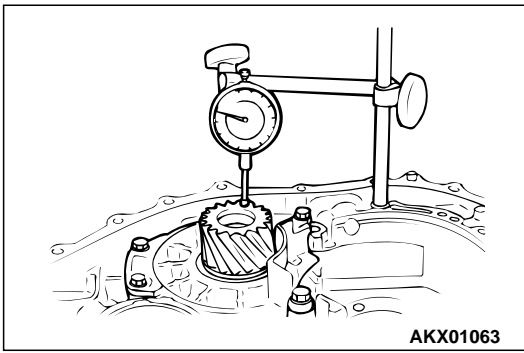

27. Move the output shaft to measure the end play and record the measurement value.

28. Remove the parts that were installed in steps 21 to 25.

29. Add 1.88 mm (0.074 inch)\* and 0.01 to 0.09 mm (0.0004 to 0.0035 inch)\*\* to the measured value in step 26 and select a spacer of the same thickness. Adjustment spacer sizes are all listed on page 23B-79. Select the most suitable one from among those listed.

*NOTE: \* is the thickness of the spacer installed in step 21. \*\* is the preload of the output shaft.*

30. Repeat steps 22 to 25 again, installing each part and using the appropriate adjustment spacer determined in step 27.

31. Stake the jam nut with a punch (two places).

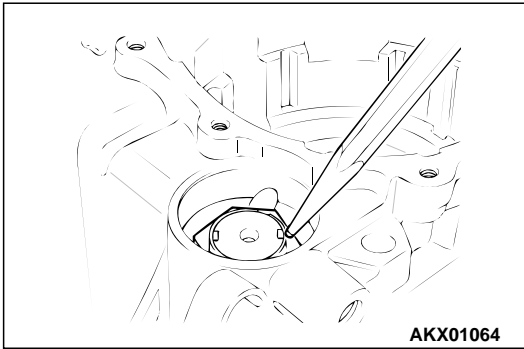

32. Use special tools MB990931 and MB990938 to install the cap as shown in the illustration.

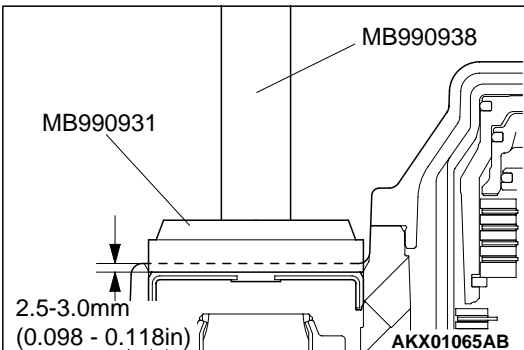

33. Install the parking pawl, spacer, and spring. Then insert the parking pawl shaft.

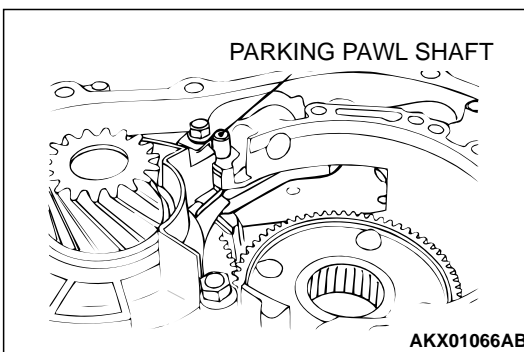

34. Install the parking roller support, and then insert the two parking roller support shafts.

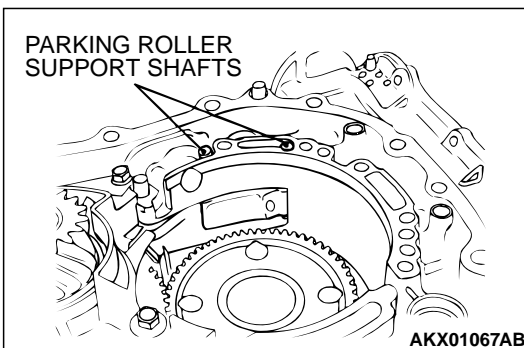

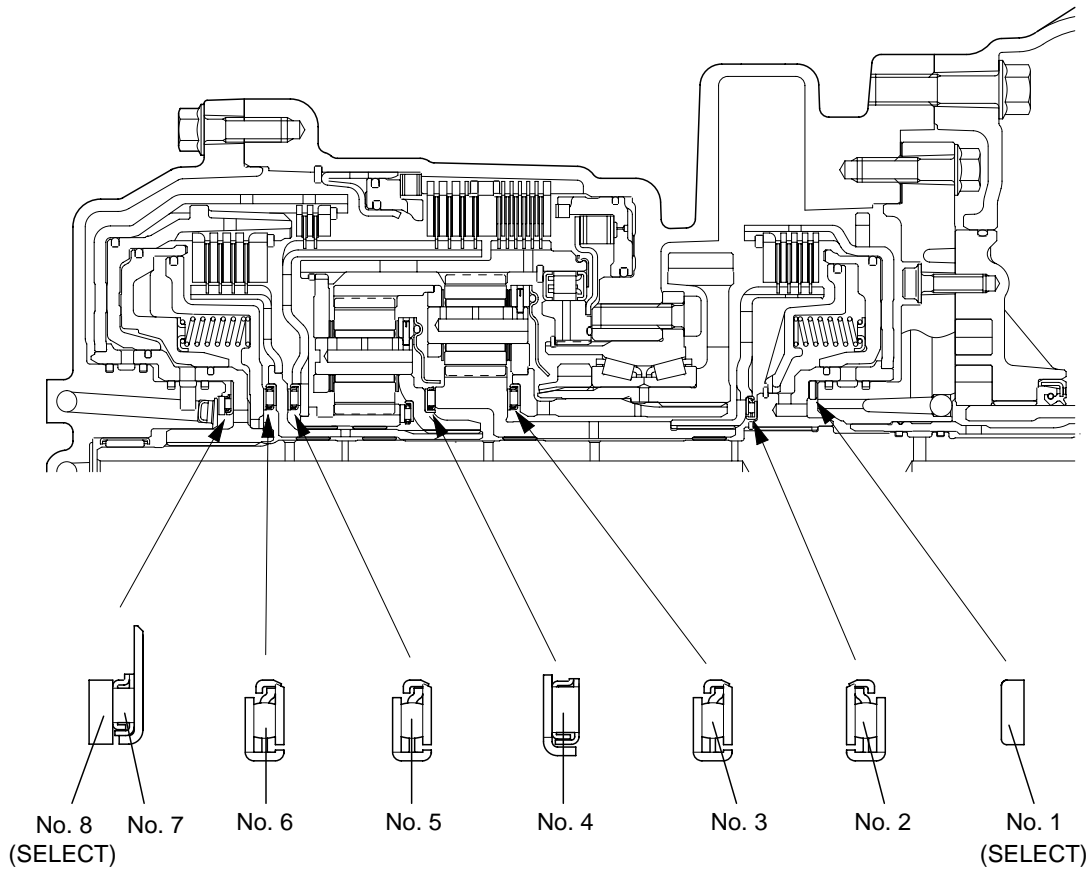

AKX01108AB

IDENTIFICATION OF THRUST BEARING, THRUST RACES,  
AND THRUST WASHERS

mm (in)

SYMBOL	OD	ID	THICKNESS	PART NO.	APPLICATION
No.1	59 (2.32)	47 (1.85)	1.8 (0.071)	MD754509	
	59 (2.32)	47 (1.85)	2.0 (0.079)	MD754508	
	59 (2.32)	47 (1.85)	2.2 (0.087)	MD754507	
	59 (2.32)	47 (1.85)	2.4 (0.094)	MD753793	
	59 (2.32)	47 (1.85)	2.6 (0.102)	MD753794	
	59 (2.32)	47 (1.85)	2.8 (0.110)	MD753795	
	49 (1.93)	36 (1.42)	3.6 (0.142)	MD756846	
No.3	49 (1.93)	36 (1.42)	3.6 (0.142)	MD756846	
	45.3 (1.783)	31 (1.22)	3.3 (0.130)	MD757647	F4A42
	55.4 (2.181)	38.5 (1.516)	3.3 (0.130)	MD761683	F4A51
No.5	49 (1.93)	36 (1.42)	3.6 (0.142)	MD756846	F4A42

TSB Revision



SYMBOL	OD	ID	THICKNESS	PART NO.	APPLICATION
	57 (2.244)	38.5 (1.516)	4.1 (0.161)	MD758556	F4A51
No.6	49 (1.93)	36 (1.42)	3.6 (0.142)	MD756846	F4A42
	57 (2.244)	38.5 (1.516)	4.1 (0.161)	MD758556	F4A51
No.7	59 (2.32)	37 (1.46)	2.8 (0.110)	MD754595	
No.8	48.9 (1.925)	37 (1.46)	1.6 (0.063)	MD707267	
	48.9 (1.925)	37 (1.46)	1.7 (0.067)	MD759681	
	48.9 (1.925)	37 (1.46)	1.8 (0.071)	MD723064	
	48.9 (1.925)	37 (1.46)	1.9 (0.075)	MD754794	
	48.9 (1.925)	37 (1.46)	2.0 (0.079)	MD707268	
	48.9 (1.925)	37 (1.46)	2.1 (0.083)	MD754795	
	48.9 (1.925)	37 (1.46)	2.2 (0.087)	MD723065	
	48.9 (1.925)	37 (1.46)	2.3 (0.091)	MD754796	
	48.9 (1.925)	37 (1.46)	2.4 (0.094)	MD724358	
	48.9 (1.925)	37 (1.46)	2.5 (0.098)	MD754797	
	48.9 (1.925)	37 (1.46)	2.6 (0.102)	MD754798	

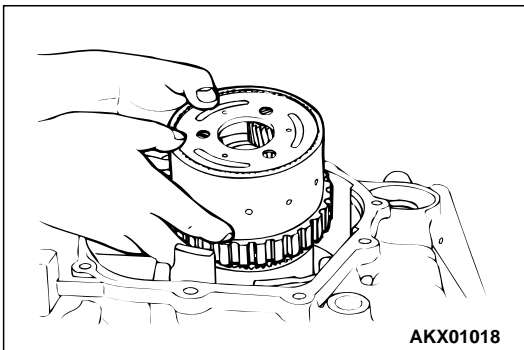

35. Install the planetary carrier assembly.

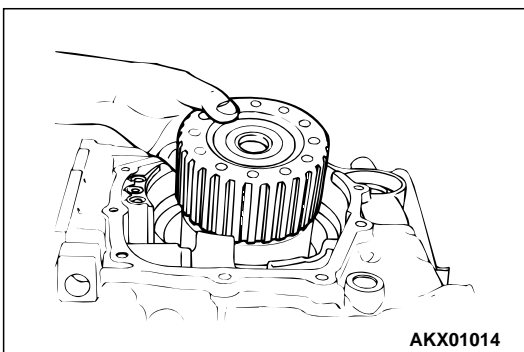

36. Install the planetary reverse sun gear.

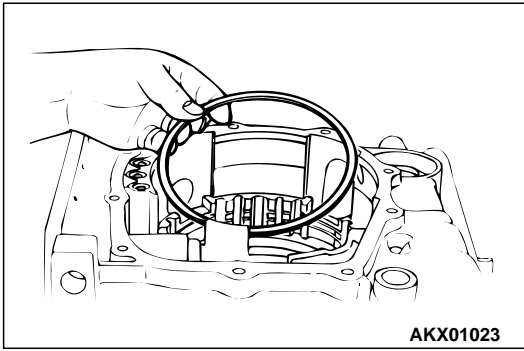

37. Install the wave spring on the low-reverse brake piston.

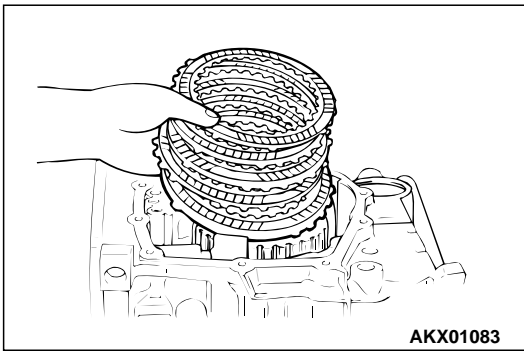

38. Install the pressure plate that was selected in step 18. Next, install six brake discs and five brake plates, one on top of the other.

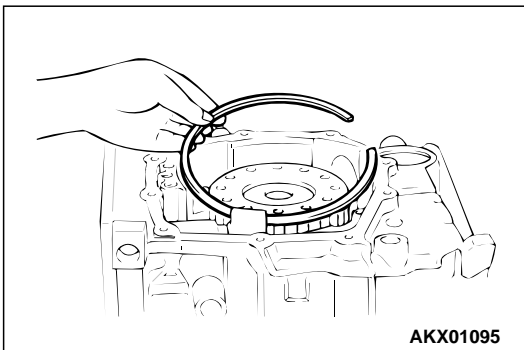

39. Install the snap ring.

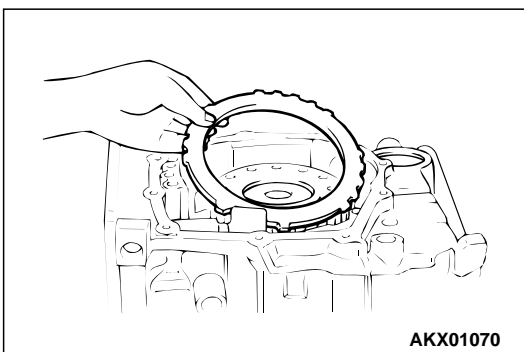

40. Install the reaction plate.

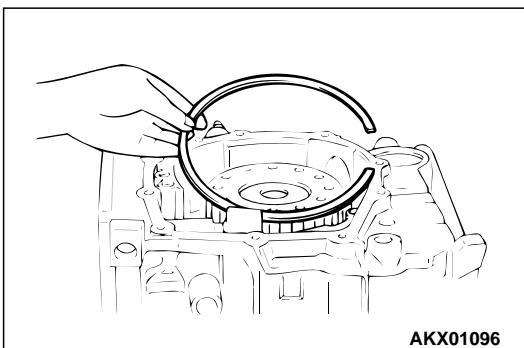

41. Install the snap ring that was selected in step 12.

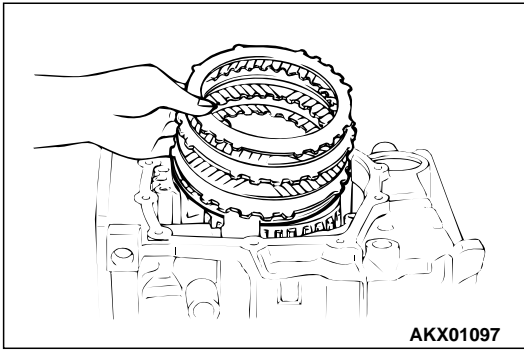

42. Install three brake discs <F4A42> or four brake discs <F4A51> and two brake plates <F4A42> or three brake plates <F4A51>, one on top of the other. Next, install the pressure plate that was selected in step 16.

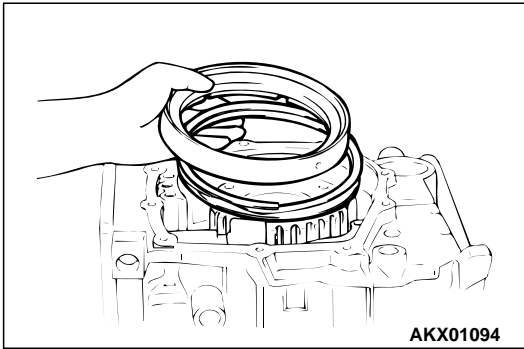

43. Install the return spring and second brake piston.

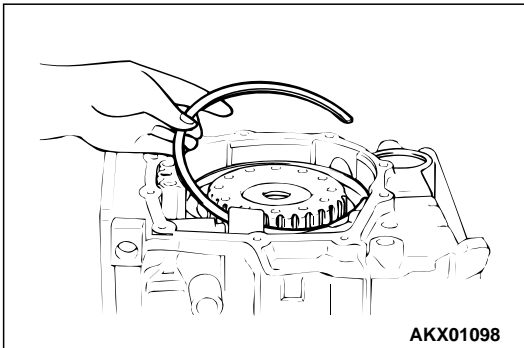

44. Install the snap ring.

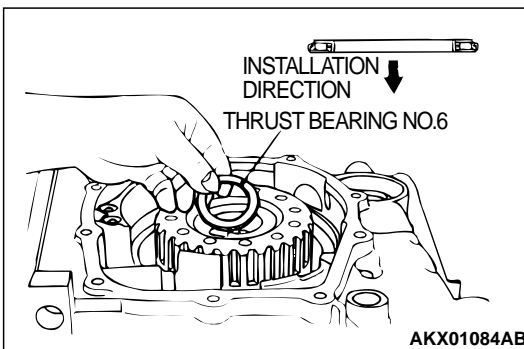

**CAUTION**

Be sure to install the thrust bearing in the correct direction as shown.

45. Check the installation direction of the thrust bearing number 5, and install it on the hub of the planetary reverse sun gear.

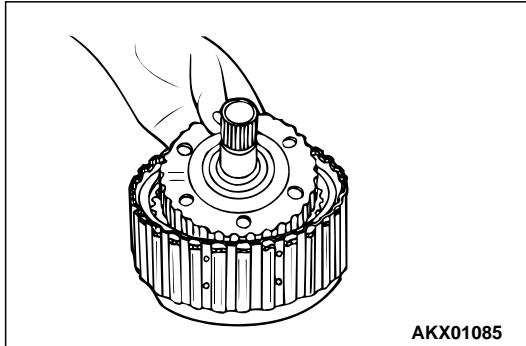
**CAUTION**

Use care to install the thrust bearing in the proper direction.

46. Attach thrust bearing number 6 to the inside of the overdrive clutch hub using petroleum jelly (Vaseline). Then install the assembly in the reverse and overdrive clutch.

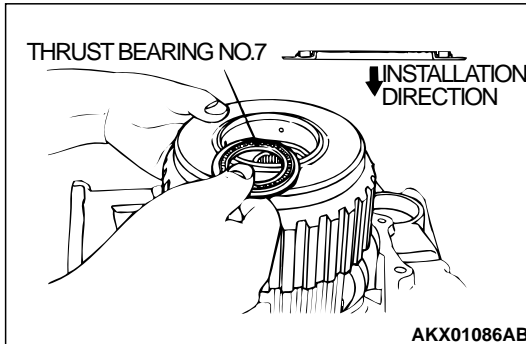

47. Install the reverse and overdrive clutch.

**CAUTION**

Be sure to install the thrust bearing in the correct direction as shown.

48. Check the installation direction of thrust bearing number 7, and install it on the reverse clutch retainer.

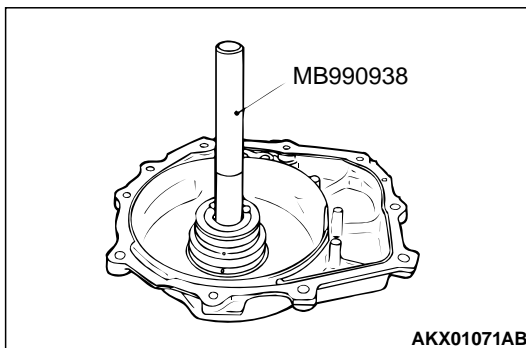

49. Use special tool MB990938 to tap the input shaft rear bearing in the rear cover.

50. Install the four seal rings in the grooves of the rear cover.

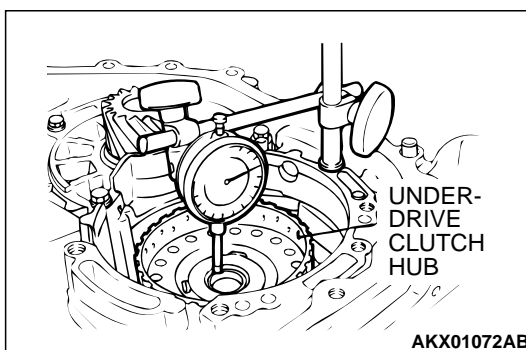

51. Measure the end play of the under drive sun gear by the following procedures:

- (1) Install the thinnest thrust race number 8 [thickness 1.6 mm (0.063 inch); part number MD707267] on thrust bearing number 7.

- (2) Install the rear cover on the transaxle case and tighten the bolts to the specified torque.

**Tightening torque: 23 N·m (17 ft·lb)**

- (3) Turn over the transaxle case so that the installation surface of the torque converter housing is facing up.
- (4) Install the under drive clutch hub on the under drive sun gear.
- (5) Measure end play of the underdrive sun gear and record the measurement value.

**Standard value (Reference):**

**0.25 – 0.45 mm (0.0098 – 0.0177 inch)**

- (6) After taking the measurements in steps (1) to (4), take out the installed parts.

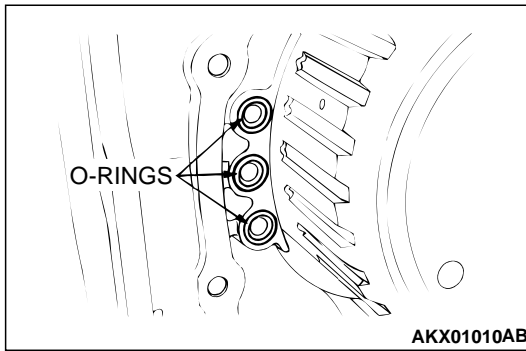

52. Install the three O-rings.

53. Select a thrust race number 8 whose thickness corresponds to the measured values taken in step 50 from the table below. Install it on thrust bearing number 7.

MEASUREMENT VALUE mm (in)	THICKNESS mm (in)	PART NO.
0.3 – 0.4 (0.012 – 0.016)	1.6 (0.063)	MD707267
0.4 – 0.5 (0.016 – 0.020)	1.7 (0.067)	MD759681
0.5 – 0.6 (0.020 – 0.024)	1.8 (0.071)	MD723064
0.6 – 0.7 (0.024 – 0.028)	1.9 (0.075)	MD754794
0.7 – 0.8 (0.028 – 0.031)	2.0 (0.079)	MD707268
0.8 – 0.9 (0.031 – 0.035)	2.1 (0.083)	MD754795
0.9 – 1.0 (0.035 – 0.039)	2.2 (0.087)	MD723065
1.0 – 1.1 (0.039 – 0.043)	2.3 (0.091)	MD754796
1.1 – 1.2 (0.043 – 0.047)	2.4 (0.094)	MD724358
1.2 – 1.3 (0.047 – 0.051)	2.5 (0.098)	MD754797
1.3 – 1.4 (0.051 – 0.055)	2.6 (0.102)	MD754798

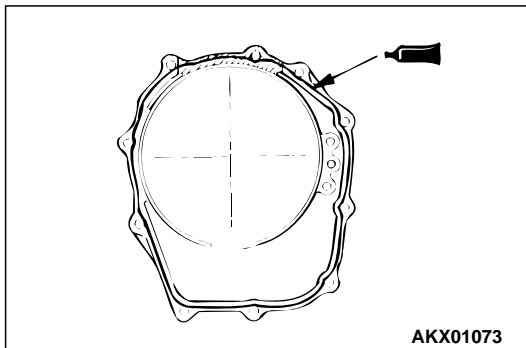

54. Apply a 2 mm (0.08 inch) diameter bead of sealant (MITSUBISHI Genuine Part number MD974421 or equivalent) to the illustrated position of the rear cover.

*NOTE: Be sure to install the case quickly while the sealant is wet (within 15 minutes).*

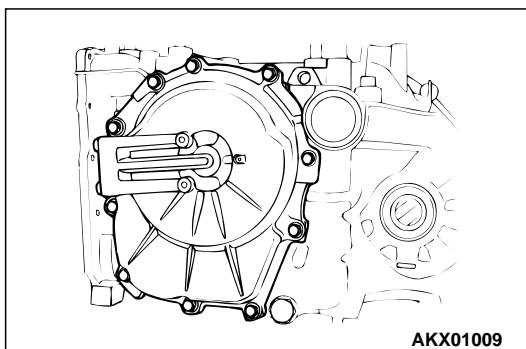

55. Install the rear cover, and tighten its mounting bolts to the specified torque.

**Tightening torque: 23 N·m (17 ft·lb)**

*NOTE: After installation, keep the sealed area away from the oil for approximately one hour.*

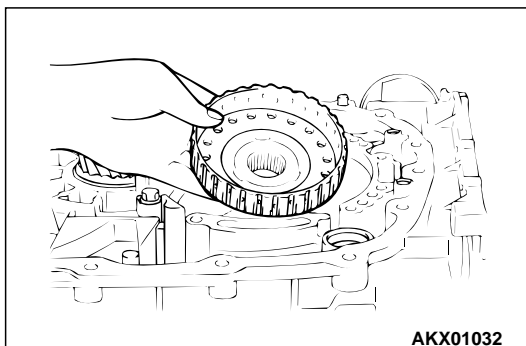

56. Install the underdrive clutch hub to the underdrive sun gear.

**⚠ CAUTION**

Be sure to install the thrust bearing in the correct direction as shown.

57. Check the installation direction of thrust bearing number 2, and install it on the underdrive clutch hub.

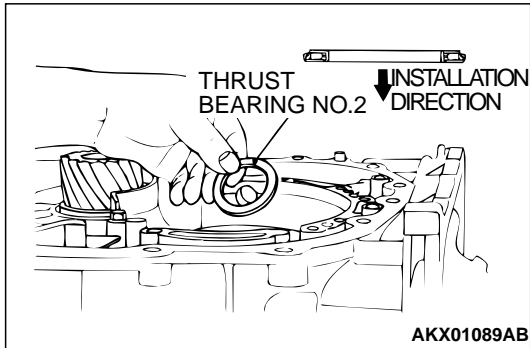

58. Hold the input shaft, and install the underdrive clutch.

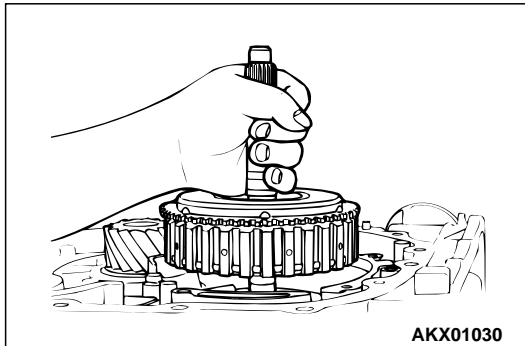

59. Place two beads of solder [each 10 mm (0.39 inch) in length, 3.5 mm (0.14 inch) in diameter] on the underdrive clutch retainer as shown in the illustration.

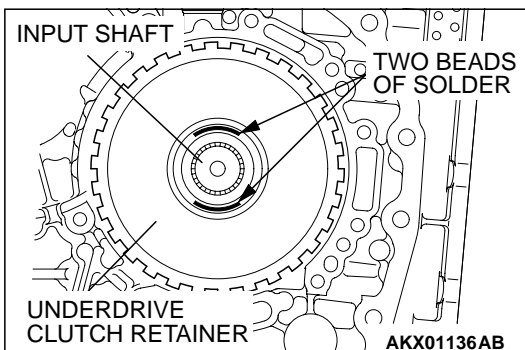

60. Install special tool MD998412 in the illustrated place.

61. Install the oil pump to the transaxle case.

*NOTE: Do not install the oil pump gasket at this time.*

62. Tighten the oil pump mounting bolts (six pieces) to the specified torque.

**Tightening torque: 23 N·m (17 ft-lb)**

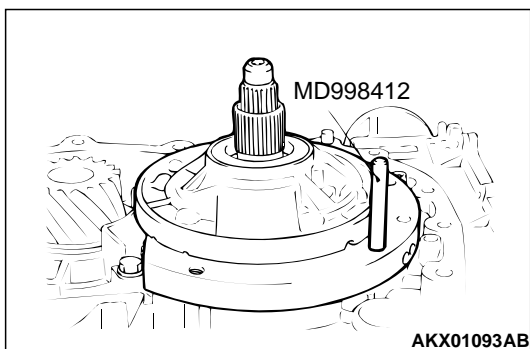

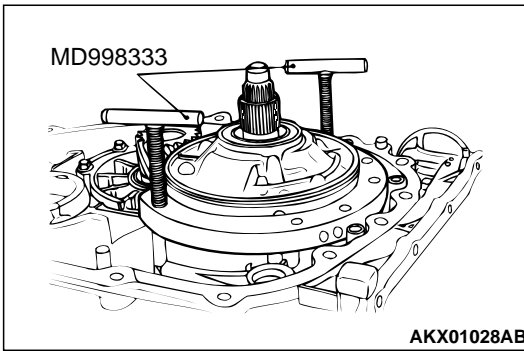

63. Remove the oil pump mounting bolts.  
64. Using special tools MD998333, remove the oil pump and the crushed solders.

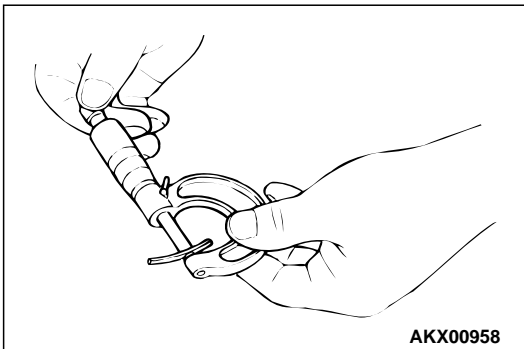

65. Use a micrometer to measure the thickness of the crushed solder beads and record the measured value.  
66. Select a thrust washer number 1 whose thickness corresponds to the measured value from table below.

MEASUREMENT VALUE mm (in)	THICKNESS mm (in)	ID SYMBOL	PART NO.
2.25 – 2.45 (0.089 – 0.096)	1.8 (0.071)	18	MD754509
2.45 – 2.65 (0.096 – 0.104)	2.0 (0.079)	20	MD754508
2.65 – 2.85 (0.104 – 0.112)	2.2 (0.087)	22	MD754507
2.85 – 3.05 (0.112 – 0.120)	2.4 (0.094)	24	MD753793
3.05 – 3.25 (0.120 – 0.128)	2.6 (0.102)	26	MD753794
3.25 – 3.45 (0.128 – 0.136)	2.8 (0.110)	28	MD753795

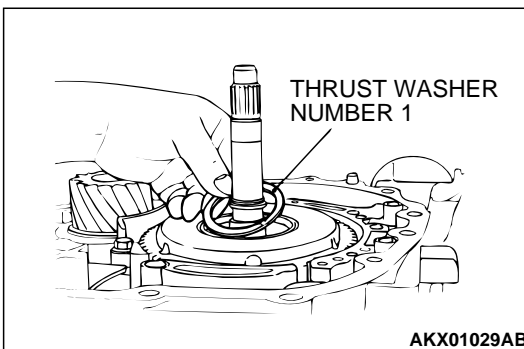

67. Install thrust washer number 1 that was selected in step 65 on the underdrive clutch retainer.

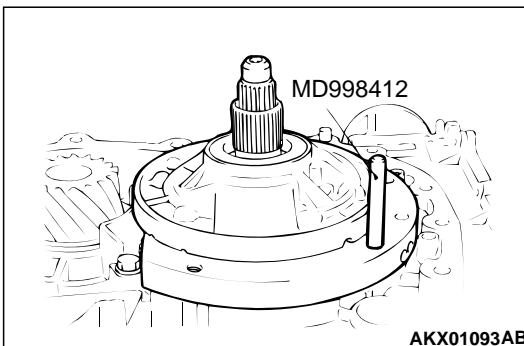

68. Install special tool MD998412 in the illustrated place.  
69. Install the new oil pump gasket on the transaxle case.  
70. Install the oil pump and tighten the mounting bolts (six pieces) to the specified torque.

**Tightening torque: 23 N·m (17 ft·lb)**

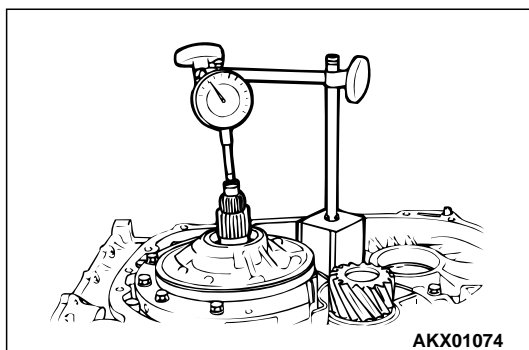

71. Make sure that the input shaft end play meets the standard value.

**Standard value: 0.70 – 1.45 mm (0.028 – 0.057 inch)**

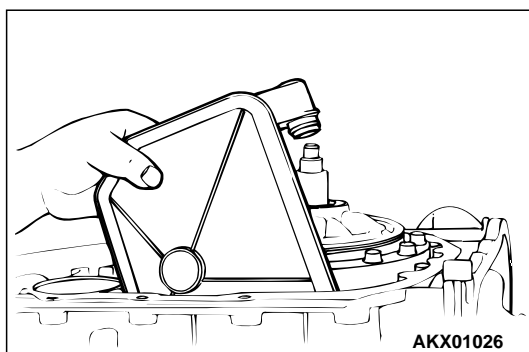

72. Install the oil filter.

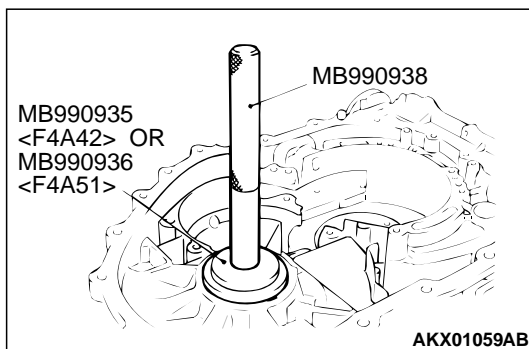

73. Use special tools MB990935 <F4A42> or MB990936 <F4A51> and MB990938 to tap the differential bearing outer race in the transaxle case.

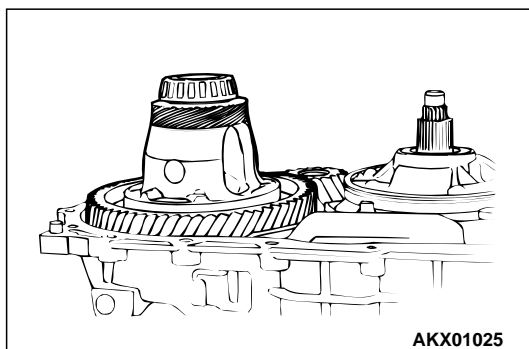

74. Install the differential.

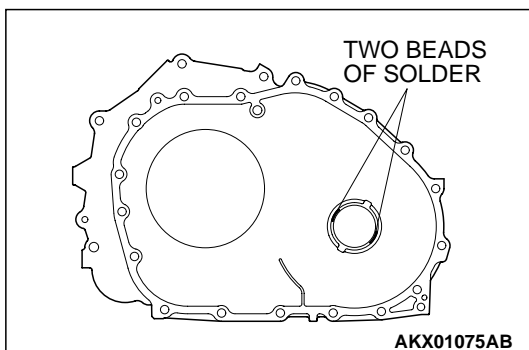

75. Place two beads of solder [each 10 mm (0.39 inch) in length, 3 mm (0.12 inch) in diameter] on the torque converter housing as shown in the illustration.



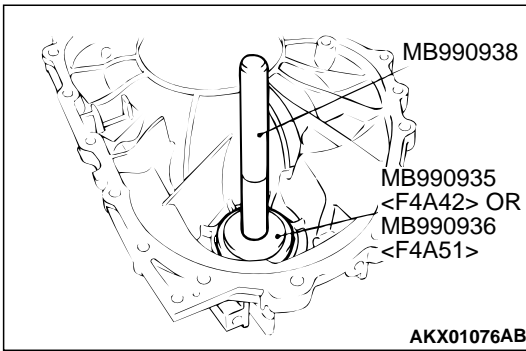

76. Use special tools MB990935 <F4A42> or MB990936 <F4A51> and MB990938 to press in the differential bearing outer race into the torque converter housing.

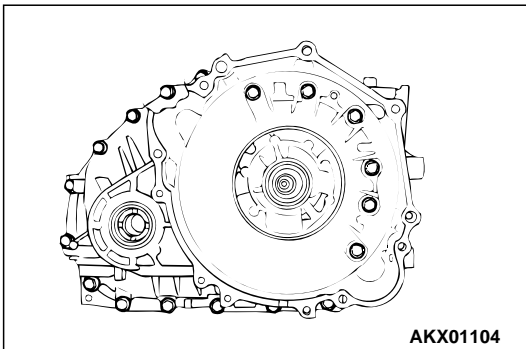

77. Install the torque converter housing to the transaxle case without applying sealant. Tighten its mounting bolts to the specified torque.

**Tightening torque: 48 N·m (35 ft·lb)**

78. Loosen all the bolts, and remove the torque converter housing. Then remove the outer race and the crushed solders.

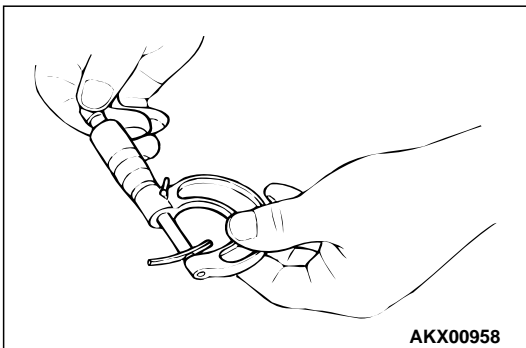

79. Use a micrometer to measure the thickness of the crushed solder beads and record the measured value. Add 0.045 to 0.105 mm (0.0018 to 0.0041 inch)\* to the measured value and select a spacer with the corresponding thickness. Adjustment spacer sizes are all listed on P.23B-79. Select the most suitable one from among those listed.

*NOTE: \* is the thickness for the differential case preload.*

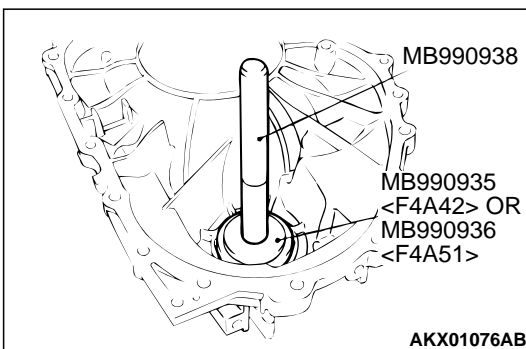

80. Install the spacer selected in step 71 to the torque converter housing.

81. Use special tools MB990935 <F4A42> or MB990936 <F4A51> and MB990938 to press the outer race into housing.

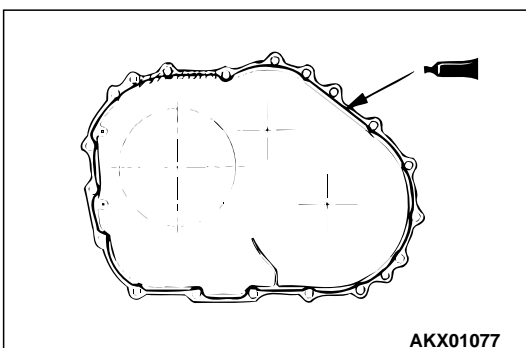

82. Apply a 2 mm (0.08 inch) diameter bead of sealant (MITSUBISHI Genuine Part number MD974421 or equivalent) to the torque converter housing in the area shown.

*NOTE: Be sure to install the case quickly while the sealant is wet (with 15 minutes).*

*NOTE: After installation, keep the sealed area away from the oil for approximately one hour.*

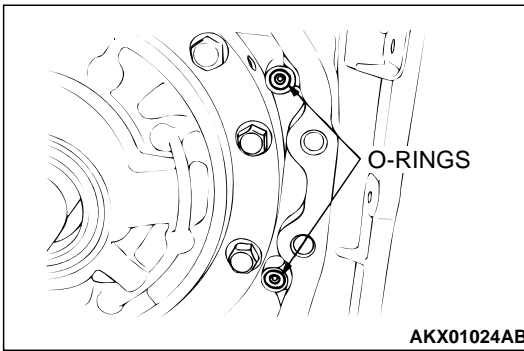

83. Install the two O-rings.

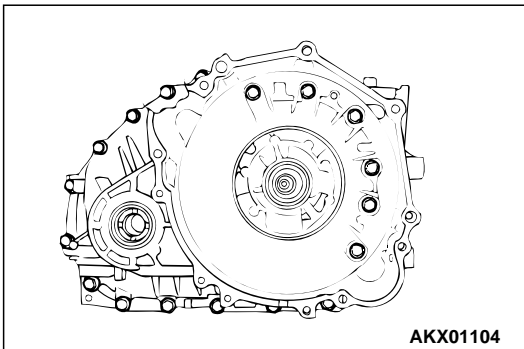

84. Install the torque converter housing and then tighten its 18 mounting bolts to the specified torque.

**Tightening torque: 48 N·m (35 ft-lb)**

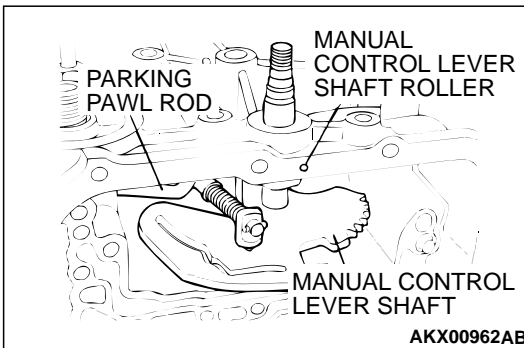

85. Insert the two O-rings into the grooves of the manual control lever shaft.

86. Install the manual control lever shaft and parking pawl rod.

87. Align hole "A" with the groove in the manual control lever shaft. Insert the manual control lever shaft roller into hole "A".

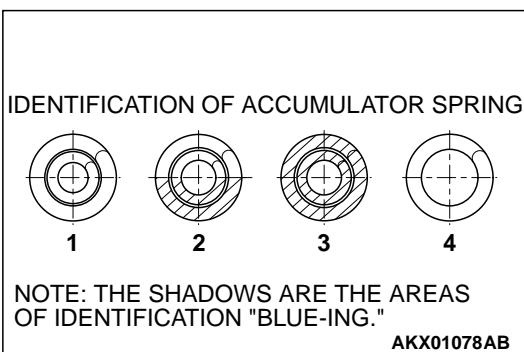

88. Insert the new seal rings in the grooves of the accumulator pistons.

*NOTE: The piston and seal ring are common parts.*

89. Identify the accumulator spring and insert it and the accumulator piston into each hole of the transaxle case.

*NOTE: Accumulator springs are identified as shown in the illustration.*

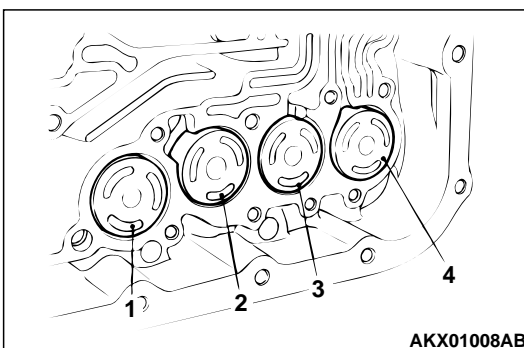

NO.	NAME	IDENTIFICATION "BLUE-ING"
1	For low-reverse brake	None
2	For underdrive clutch	Half
3	For second brake	Whole surface
4	For overdrive clutch	None

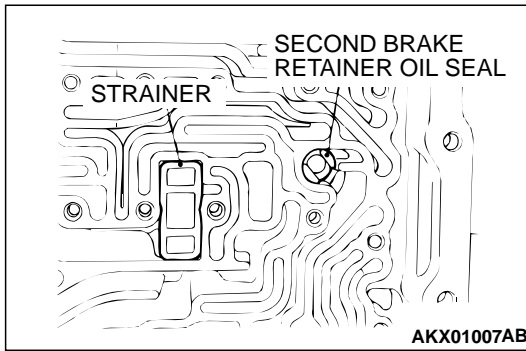

90. Install the strainer and second brake retainer oil seal.

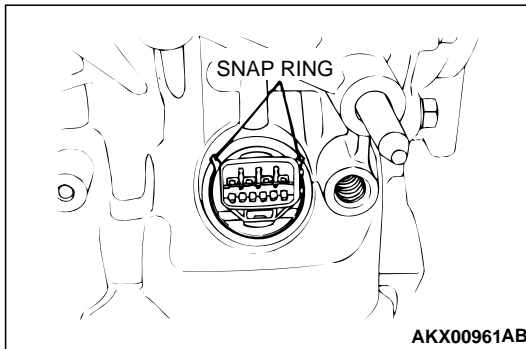

91. Insert a new O-ring to the groove of the solenoid valve harness connector.

92. Insert the solenoid valve harness connector into the hole from the inside of the transaxle case so it is oriented as shown in the illustration. Then secure the snap ring to the connector groove.

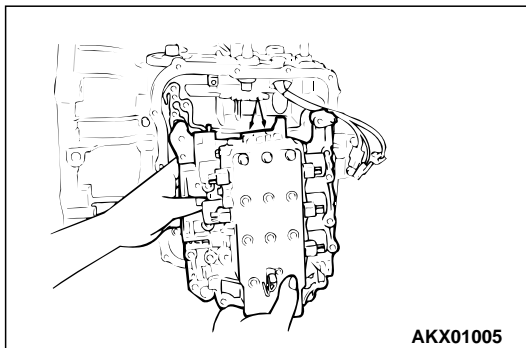

93. Install a steel ball into each of the two holes in the top face of the valve body (outside valve body).

94. Install the valve body and gasket to the transaxle case. Make sure that the manual valve's pin is in the groove in the detent plate of the manual control lever.

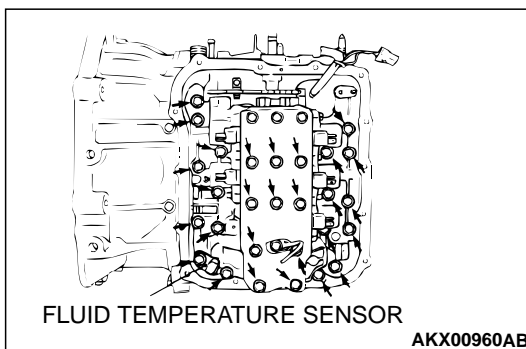

95. Install the fluid temperature sensor.

96. Install the 28 valve body mounting bolts, and tighten to the specified torque.

**Tightening torque: 11 N·m (95 in-lb)**

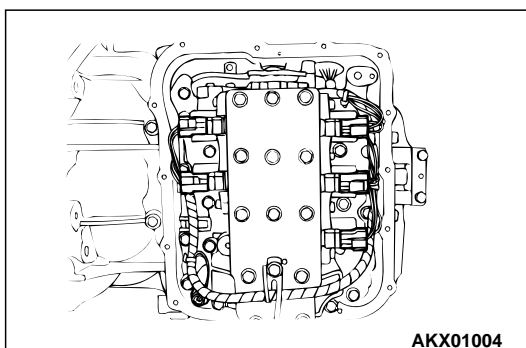

97. Connect the solenoid valve harness connectors to the valve body connectors and the fluid temperature sensor connector.

NO.	PARTS TO BE CONNECTED	SOLENOID VALVE HARNESS	
		CABLE COLOR	CONNECTOR HOUSING COLOR
1	Underdrive solenoid valve	White, red, red	Black
2	Overdrive solenoid valve	Orange, red	Black
3	Low-reverse solenoid valve	Brown, yellow	Milky white
4	Second solenoid valve	Green, red, red	Milky white
5	Torque converter clutch control solenoid valve	Blue, yellow, yellow	Black
6	Fluid temperature sensor	Black, red	Black

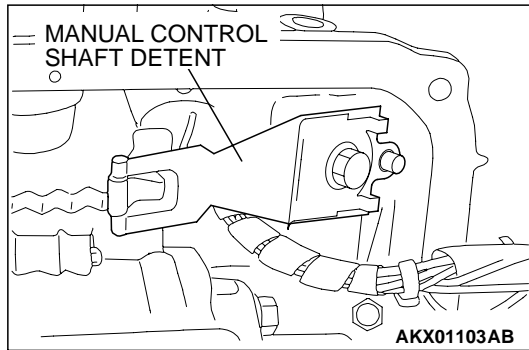

98. Install the manual control shaft detent and tighten the bolt to the specified torque.

**Tightening torque: 6 N·m (52 in·lb)**

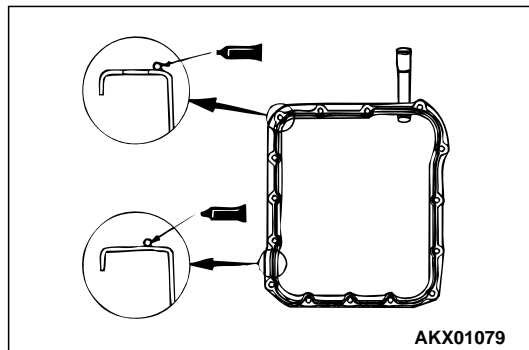

99. Apply a 2 mm (0.08 inch) diameter bead of sealant (MITSUBISHI Genuine Part number MD974421 or equivalent) to the valve body cover in the area shown.  
*NOTE: Be sure to install the case quickly while the sealant is wet (with 15 minutes).*

*NOTE: After installation, keep the sealed area away from the oil for approximately one hour.*

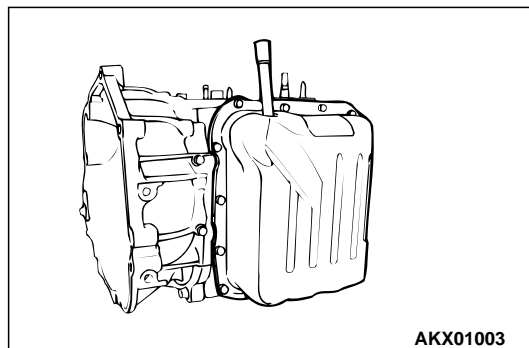

100. Install the valve body cover, and then tighten its mounting bolts to the specified torque.

**Tightening torque: 11 N·m (95 in·lb)**

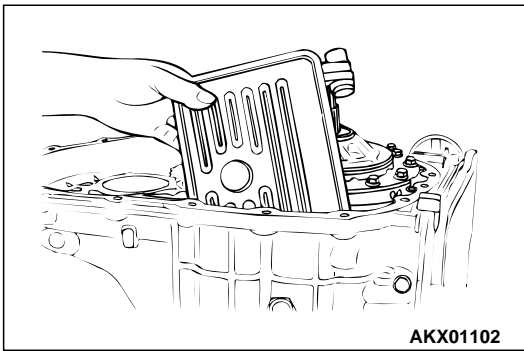

101. Install the speedometer gear and tighten the bolt to the specified torque.

**Tightening torque: 5 N·m (43 in-lb)**

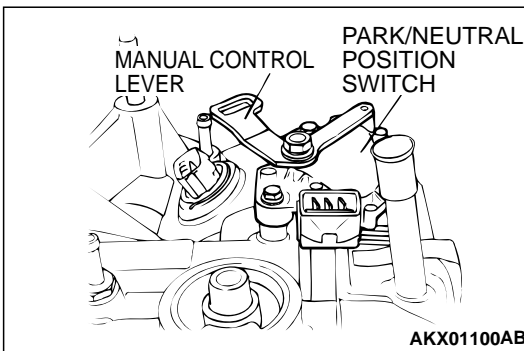

102. Install the park/neutral position switch and tighten the bolt to specified torque.

**Tightening torque: 11 N·m (95 in-lb)**

103. Install the manual control lever and tighten the nut to specified torque.

**Tightening torque: 22 N·m (16 ft-lb)**

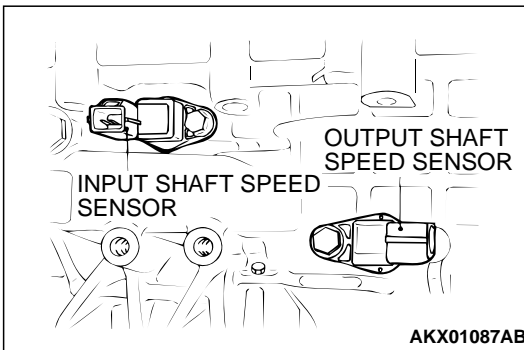

104. Install the input shaft speed sensor and output shaft speed sensor and tighten the bolt to the specified torque.

**Tightening torque: 11 N·m (95 in-lb)**

105. Install the oil cooler feed tube together with new gaskets and tighten the eye bolts to the specified torque.

**Tightening torque: 30 N·m (22 ft-lb)**

106. Tighten the oil cooler feed pipe clamp bolt.

**Tightening torque: 11 N·m (95 in-lb)**

107. Install the oil dipstick.

108. Install the cable support bracket.

**Tightening torque: 23 N·m (17 ft-lb)**

109. Install the roll stopper brackets.

**Tightening torque: 69 N·m (51 ft-lb)**

**⚠ CAUTION**

**Apply ATF to the oil pump drive hub before installing the torque converter. Be careful not to damage the oil seal lip when installing the torque converter.**

110. Install the torque converter, and secure it so that the shown dimension "A" meets the reference value.

**Reference value:**

**Approximately 12.2 mm (0.48 inch) <F4A42>**

**Approximately 9.4 mm (0.37 inch) <F4A51>**

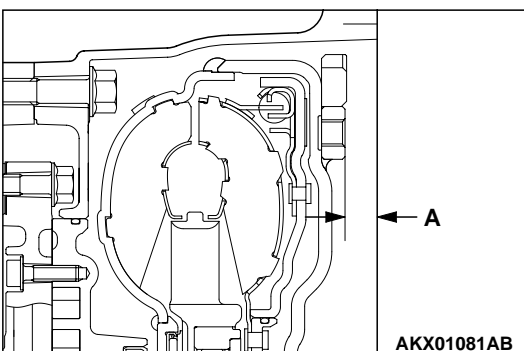

# OIL PUMP

## DISASSEMBLY AND ASSEMBLY

M1233001300024

 APPLY AUTOMATIC TRANSMISSION FLUID TO ALL MOVING PARTS BEFORE INSTALLATION.

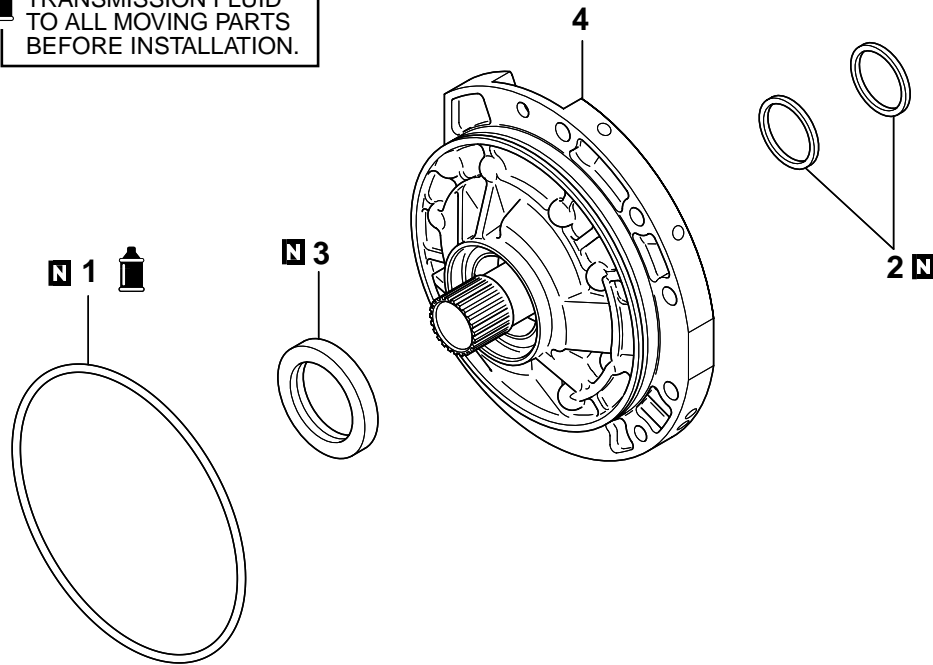

AKX01125AB

- >>B<<** **DISASSEMBLY STEPS**
1. O-RING
  2. SEAL RING

- >>A<<** **DISASSEMBLY STEPS (Continued)**
3. OIL SEAL
  4. OIL PUMP ASSEMBLY

**Required Special Tool:**  
MD998334: Oil Seal Installer

### ASSEMBLY SERVICE POINTS

#### >>A<< OIL SEAL INSTALLATION

1. Apply a small amount of ATF to the lip of oil seal.
2. Use special tool MD998334 to tap the oil seal in the oil pump body.

#### >>B<< O-RING INSTALLATION

Install a new O-ring to the outer groove of the oil pump, and apply ATF or petroleum jelly (Vaseline) to the O-ring.

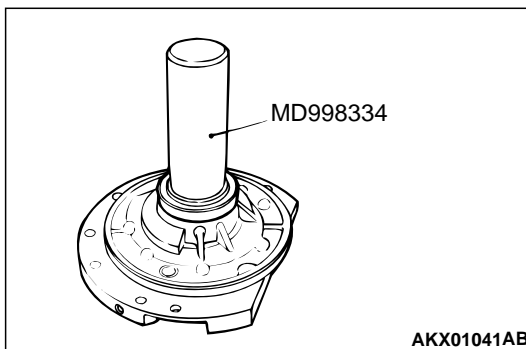

# UNDERDRIVE CLUTCH AND INPUT SHAFT

## DISASSEMBLY AND ASSEMBLY

M1233024500029

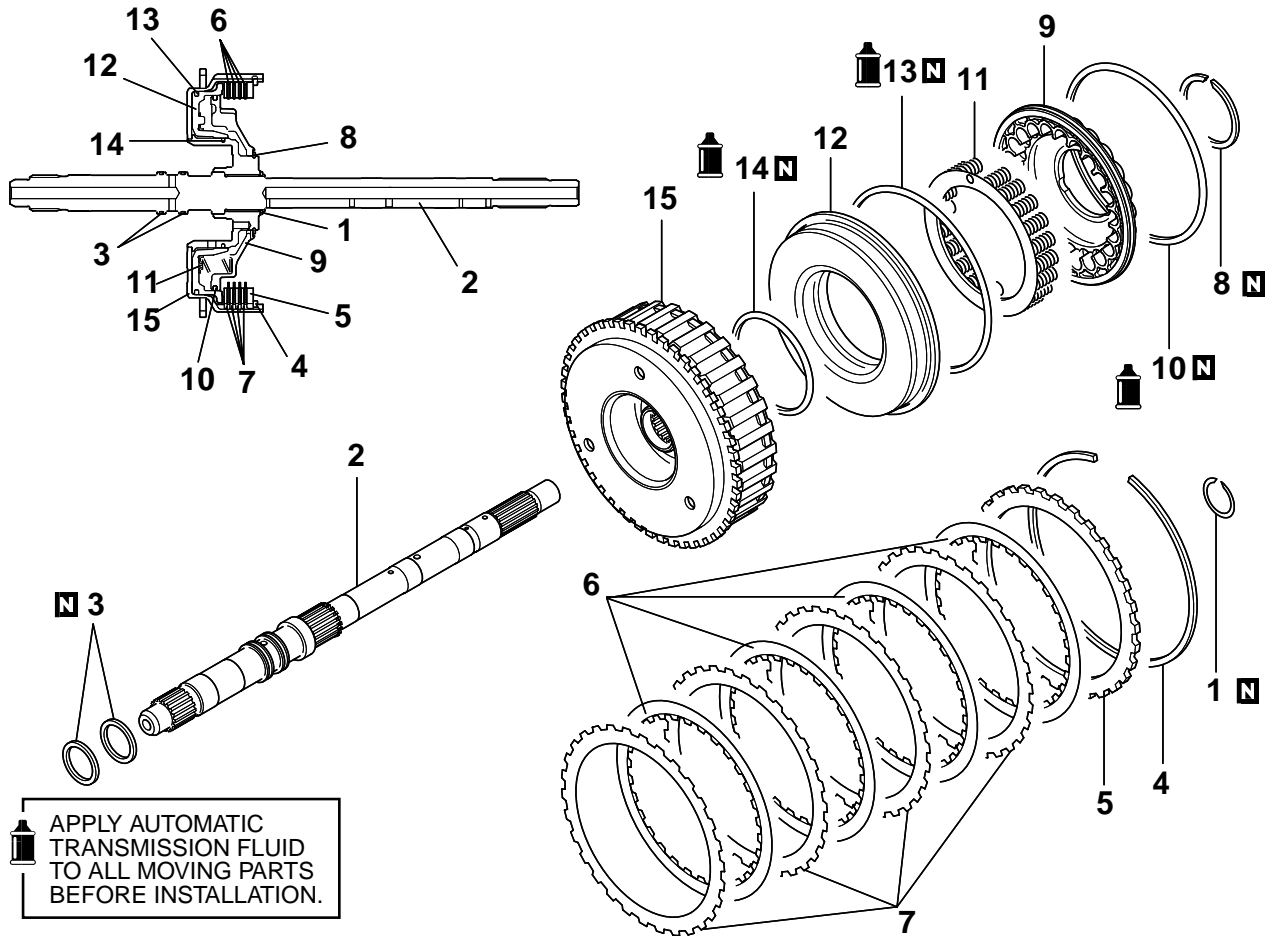

AKX01126 AB

### DISASSEMBLY STEPS

1. SNAP RING
2. INPUT SHAFT
3. SEAL RING
- >>D<< 4. SNAP RING
- >>C<< 5. CLUTCH REACTION PLATE
- >>C<< 6. CLUTCH DISC
- <<A>> >>C<< 7. CLUTCH PLATE
- >>B<< 8. SNAP RING

### DISASSEMBLY STEPS (Continued)

9. SPRING RETAINER
- >>A<< 10. D-RING
11. RETURN SPRING
- >>A<< 12. UNDERDRIVE CLUTCH PISTON
- >>A<< 13. D-RING
- >>A<< 14. D-RING
15. UNDERDRIVE CLUTCH RETAINER

### Required Special Tools:

- MB991628: Spring Compressor <F4A42>  
 MB991629: Spring Compressor <F4A51>

- MD998907: Spring Compressor  
 MD998924: Spring Compressor Retainer

**DISASSEMBLY SERVICE POINT****<<A>> SNAP RING REMOVAL**

1. Set special tools MD998907 and MD998924 as shown in the illustration.
2. Compress the return spring and remove the snap ring.

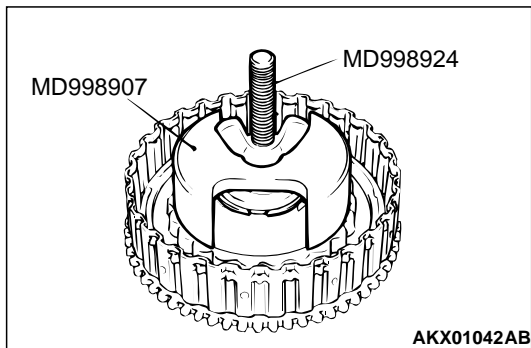
**ASSEMBLY SERVICE POINTS****>>A<< D-RING INSTALLATION**

1. Install a D-ring in the groove in the underdrive clutch retainer and piston, and in the groove in the outside of the spring retainer. Be careful not to twist or damage the D-rings.
2. Apply ATF or petroleum jelly (Vaseline) to the D-rings.

**>>B<< SNAP RING INSTALLATION**

1. Place the snap ring on top of the spring retainer, and then set special tool MD998907 as shown in the illustration.
2. Compress the return spring and install the snap ring.

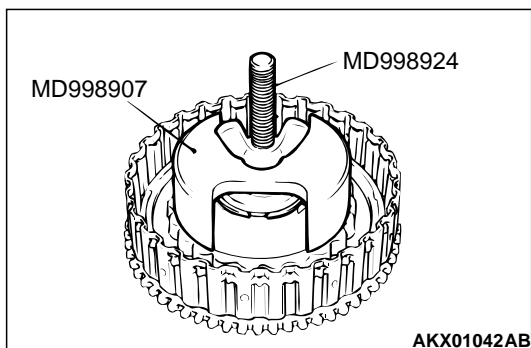



**>>C<< CLUTCH PLATE/CLUTCH DISC/CLUTCH REACTION  
PLATE INSTALLATION**

**⚠ CAUTION**

**Immerse the clutch disc in ATF before assembling it. Especially if the clutch disc is new, use it only after it has been immersed in ATF for at least two hours.**

1. Assemble the four clutch plates and four clutch discs one on top of the other inside the underdrive clutch retainer. All four clutch plates should be assembled so that the places with no teeth (marked "A") are aligned with the holes in the retainer (marked "B").
2. Install the clutch reaction plate in the direction shown. In the same way as the clutch plates, assemble them so that the areas with no teeth (marked "A") are aligned with the holes in the retainer (marked "B").

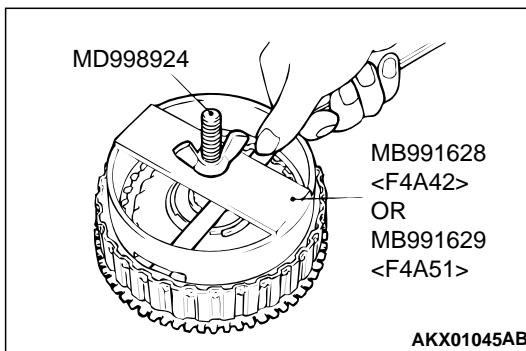
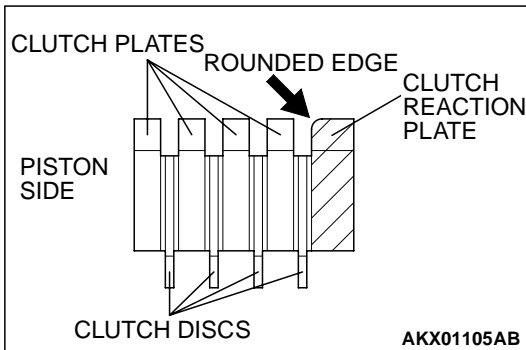
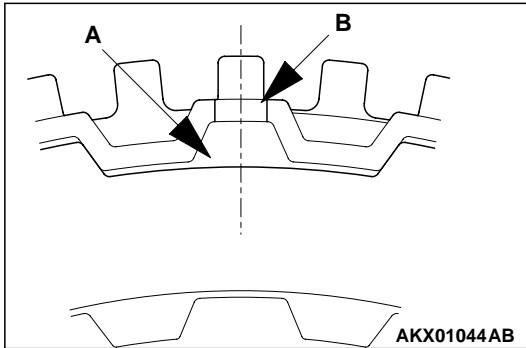

**>>D<< SNAP RING INSTALLATION**

1. Install the snap ring into the groove of clutch retainer.
2. Set special tools MB991628 <F4A42>, MB991629 <F4A51> and MD998924 as shown in the illustration, and then compress the clutch element.
3. Check that the clearance between the snap ring and the clutch reaction plate is within the standard value. If not within the standard value, select a snap ring to adjust.

**Standard value: 1.6 – 1.8 mm (0.0630 – 0.0709 inch)**

## REVERSE AND OVERDRIVE CLUTCH

**DISASSEMBLY AND ASSEMBLY**

M1233024800020

**NUMBER OF CLUTCH DISCS AND PLATES**

	MODEL	PRESSURE PLATE	CLUTCH DISC	CLUTCH PLATE	CLUTCH REACTION PLATE
Over drive clutch	F4A42	-	4	4	1
	F4A51	1	4	3	1
Reverse clutch		-	2	2	1

 APPLY AUTOMATIC TRANSMISSION FLUID TO ALL MOVING PARTS BEFORE INSTALLATION.

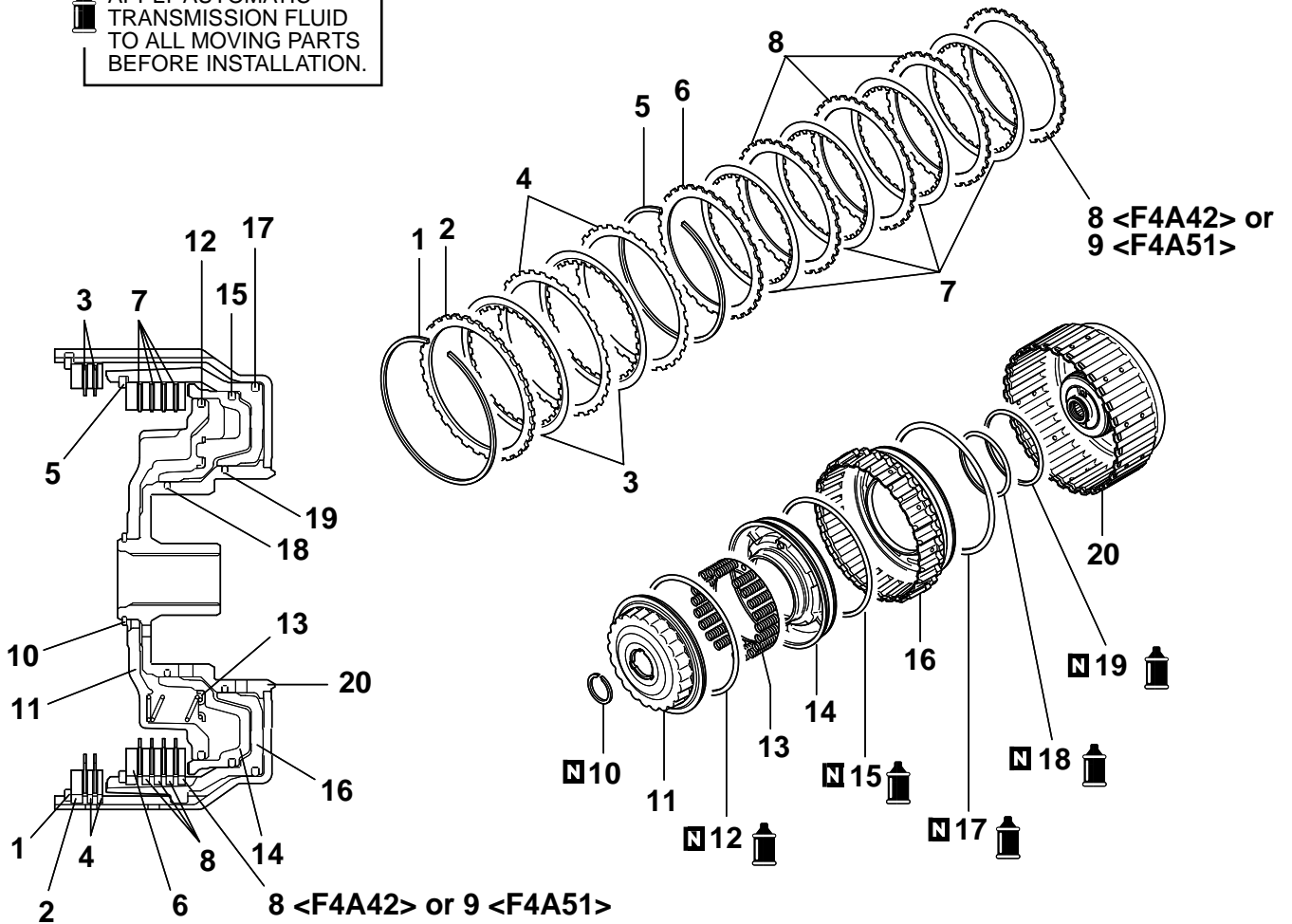

AKX01127AB

**DISASSEMBLY STEPS**

- >>G<< 1. SNAP RING
- >>F<< 2. CLUTCH REACTION PLATE
- >>F<< 3. CLUTCH DISC
- >>F<< 4. CLUTCH PLATE
- >>E<< 5. SNAP RING
- >>D<< 6. CLUTCH REACTION PLATE
- >>D<< 7. CLUTCH DISC
- >>D<< 8. CLUTCH PLATE
- >>D<< 9. PRESSURE PLATE <F4A51>
- <<A>> >>C<< 10. SNAP RING

**DISASSEMBLY STEPS (Continued)**

- 11. SPRING RETAINER
- >>A<< 12. D-RING
- 13. RETURN SPRING
- 14. OVERDRIVE CLUTCH PISTON
- >>A<< 15. D-RING
- >>B<< 16. REVERSE CLUTCH PISTON
- >>A<< 17. D-RING
- >>A<< 18. D-RING
- >>A<< 19. D-RING
- 20. REVERSE CLUTCH RETAINER

**Required Special Tools:**

- MB991628: Spring Compressor <F4A42>
- MB991629: Spring Compressor <F4A51>
- MB991789: Spring Compressor <F4A51>

MB991790: Spring Compressor <F4A42>

MD998924: Spring Compressor Retainer

MD999590: Spring Compressor

## DISASSEMBLY SERVICE POINT

### <<A>> SNAP RING REMOVAL

1. Set special tools MD999590 and MD998924 as shown in the illustration.
2. Compress the return spring and remove the snap ring.

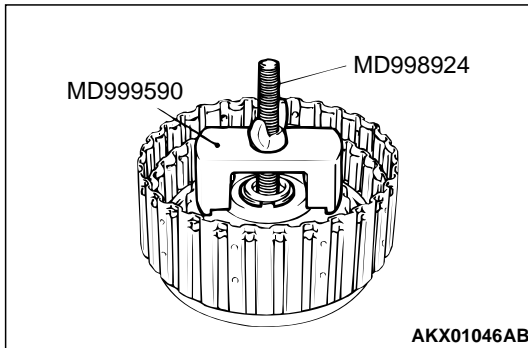

## ASSEMBLY SERVICE POINTS

### >>A<< D-RING INSTALLATION

1. Install D-rings in the grooves on the reverse clutch retainer, piston, overdrive clutch piston and spring retainer. Be careful not to twist or damage the D-rings.
2. Apply ATF or petroleum jelly (Vaseline) to D-rings.

### >>B<< REVERSE CLUTCH PISTON INSTALLATION

Align the outer circumference holes ("A" and "B") of the reverse clutch piston and the reverse clutch retainer to assemble them.

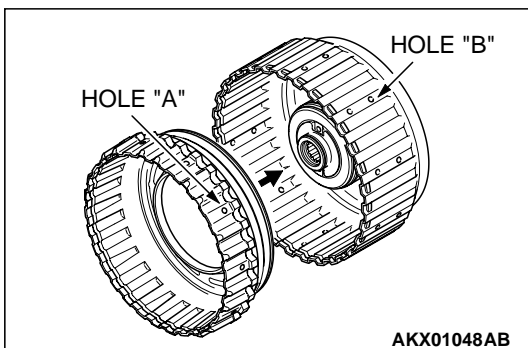

### >>C<< SNAP RING INSTALLATION

1. Set special tools MD999590 and MD998924 as shown in the illustration.
2. Tighten the nut on the special tool to press down on the spring retainer and reverse clutch retainer, and then install the snap ring.
3. Check that the clearance between the snap ring and the return spring retainer is within the standard value. If not within the standard value, select a snap ring to adjust.

**Standard value: 0 – 0.09 mm (0 – 0.0035 inch)**

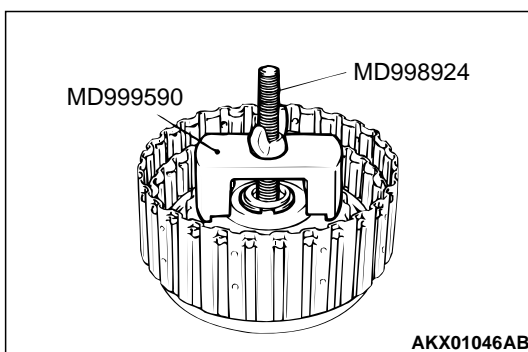

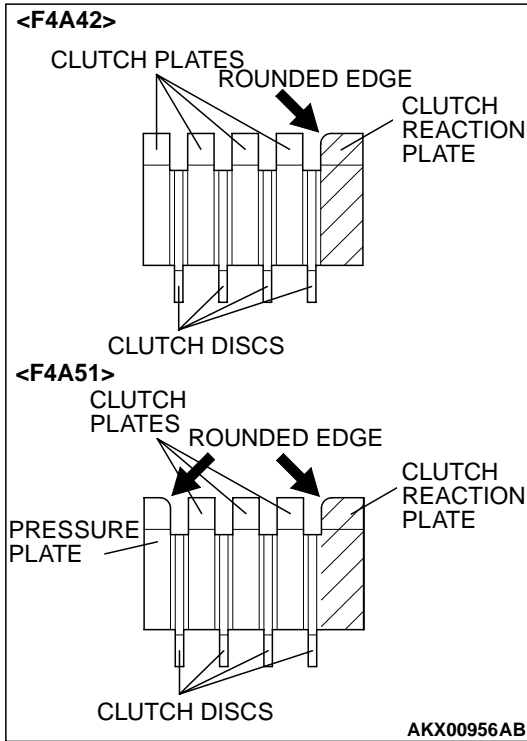

**>>D<< PRESSURE PLATE/CLUTCH PLATE/CLUTCH DISC/  
CLUTCH REACTION PLATE INSTALLATION**

1. Install the pressure plate in the direction shown <F4A51>.

**⚠ CAUTION**

**Immerse the clutch disc in ATF before assembling it. Especially if the clutch disc is new, use it only after it has been immersed in ATF for more than two hours.**

2. Assemble the clutch discs and clutch plates, one on top of the other, inside the reverse clutch piston.

**NUMBER OF CLUTCH DISCS AND PLATES**

MODEL	PRESSURE PLATE	CLUTCH DISC	CLUTCH PLATE	CLUTCH REACTION PLATE
F4A42	-	4	4	1
F4A51	1	4	3	1

3. Install the clutch reaction plate in the direction shown.

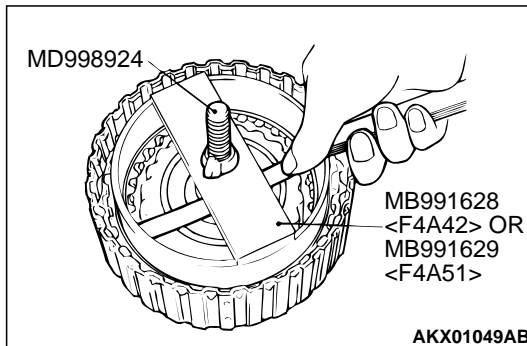

**>>E<< SNAP RING INSTALLATION**

1. Install the snap ring into the groove in the reverse clutch piston.

2. Set special tools MB991628 <F4A42>, MB991629 <F4A51> and MD998924 as shown in the illustration, and compress the clutch element.

3. Check that the clearance between the snap ring and the clutch reaction plate is within the standard value. If not within the standard value, select a snap ring to adjust.

**Standard value: 1.6 – 18 mm (0.0630 – 0.0709 inch)**

>>F<< CLUTCH PLATE/CLUTCH DISC/CLUTCH REACTION  
PLATE INSTALLATION

**CAUTION**

Immerse the clutch disc in ATF before assembling it. Especially if the clutch disc is new, use it only after it has been immersed in ATF for at least two hours.

1. Assemble two clutch discs and two clutch plates, one on top of the other, inside the reverse clutch retainer. Assemble both clutch plates so that the places with no teeth (marked "A") are aligned with the holes in the retainer (marked "B").
2. Install the clutch reaction plate in the direction shown. In the same way as the clutch plate, assemble them so that the places with no teeth (marked "A") are aligned with the holes in the retainer (marked "B").

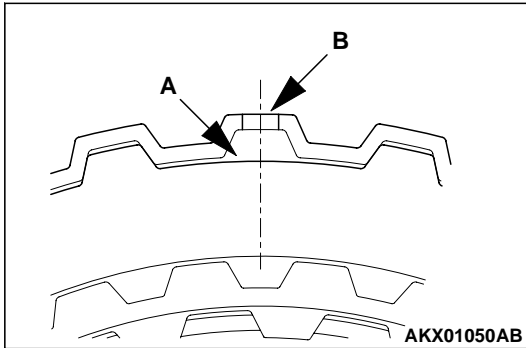

AKX01050AB

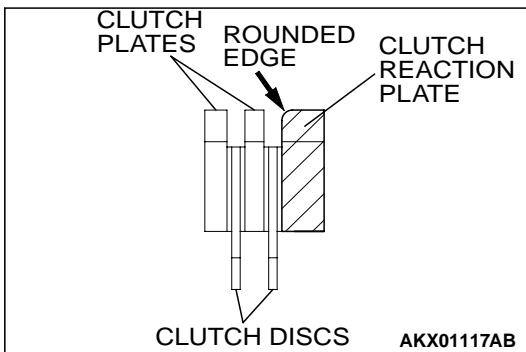

AKX01117AB

>>G<< SNAP RING INSTALLATION

1. Install the snap ring into the groove of reverse clutch retainer.
2. Set special tools MB991790 <F4A42> or MB991789 <F4A51> and MD998924 as shown in the illustration, and compress the clutch element.
3. Check that the clearance between the snap ring and the clutch reaction plate is within the standard value. If not within the standard value, select a snap ring to adjust.

**Standard value: 1.5 – 1.7 mm (0.0591 – 0.0669 inch)**

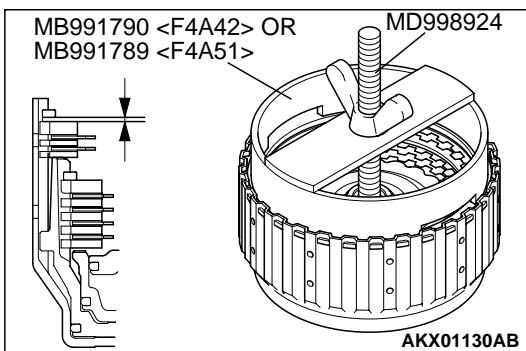

AKX01130AB

PLANETARY GEAR

DISASSEMBLY AND ASSEMBLY

M1233002500021

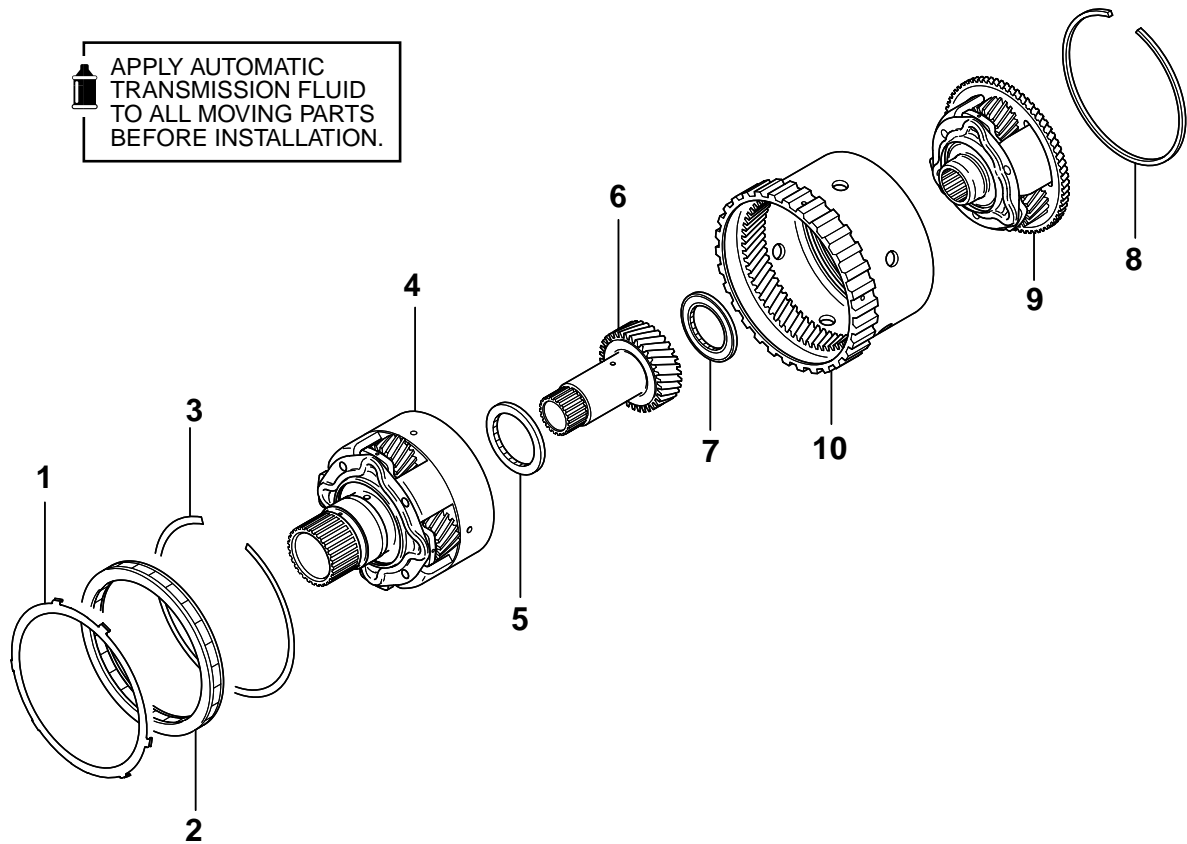

AKX01111AB

**DISASSEMBLY STEPS**

- 1. STOPPER PLATE
- >>B<< 2. ONE-WAY CLUTCH
- 3. SNAP RING
- 4. OUTPUT PLANETARY CARRIER
- >>A<< 5. THRUST BEARING NUMBER 3

**DISASSEMBLY STEPS (Continued)**

- 6. UNDERDRIVE SUN GEAR
- >>A<< 7. THRUST BEARING NUMBER 4
- 8. SNAP RING
- 9. OVERDRIVE PLANETARY CARRIER
- 10. OVERDRIVE ANNULUS GEAR

### ASSEMBLY SERVICE POINTS

#### >>A<< THRUST BEARING NUMBER 4 AND THRUST BEARING NUMBER 3 INSTALLATION

**⚠ CAUTION**

Use care to install the thrust bearings in the correct direction.

Check the installation direction of thrust bearings number 3 and 4, and install them as shown.

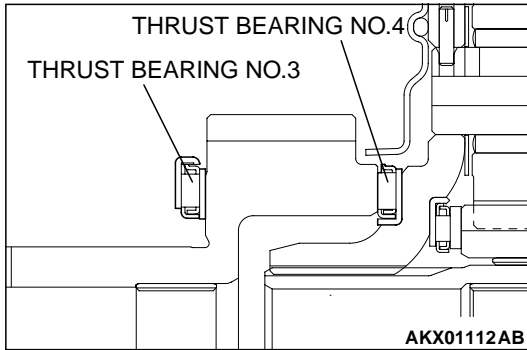

#### >>B<< ONE-WAY CLUTCH INSTALLATION

Insert the one-way clutch into the overdrive annulus gear so that the arrow points the output planetary carrier.

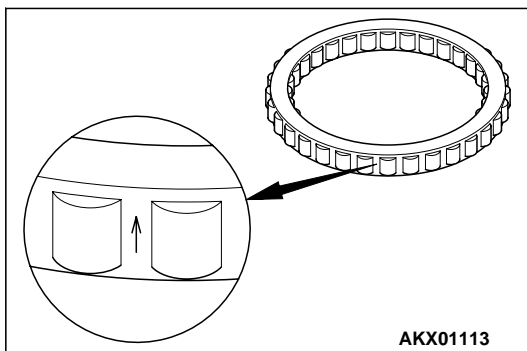

**LOW-REVERSE BRAKE****DISASSEMBLY AND ASSEMBLY**

M1233003700028

 APPLY AUTOMATIC  
 TRANSMISSION FLUID  
 TO ALL MOVING PARTS  
 BEFORE INSTALLATION.

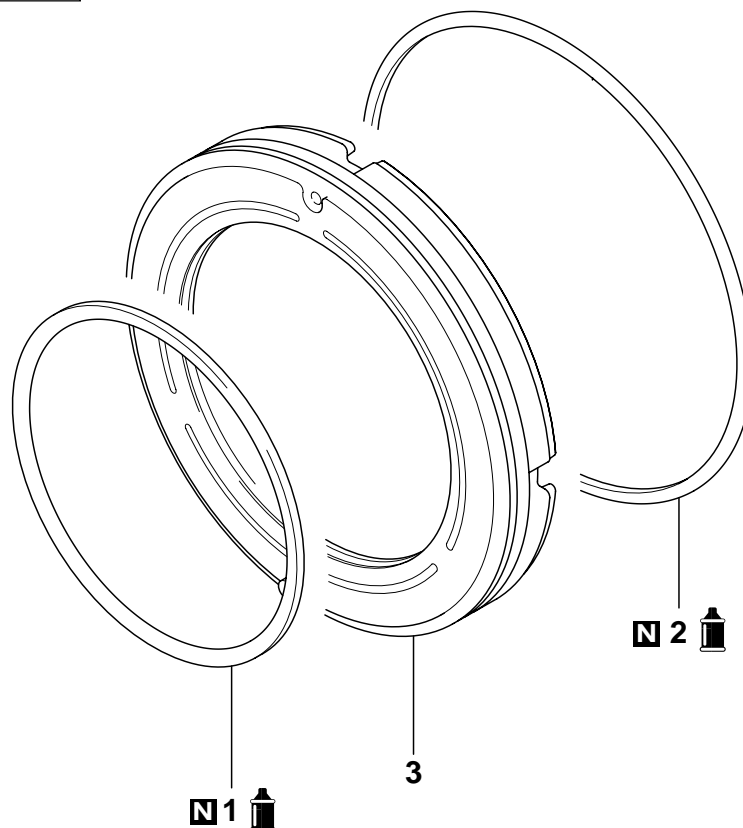

AKX01128 AB

**>>A<< DISASSEMBLY STEPS**  
 1. D-RING

**>>A<< DISASSEMBLY STEPS (Continued)**  
 2. D-RING  
 3. LOW-REVERSE BRAKE PISTON

**ASSEMBLY SERVICE POINT****>>A<< D-RING INSTALLATION**

Apply ATF or petroleum jelly (Vaseline) to the D-ring, and install carefully.

TSB Revision
--------------



## SECOND BRAKE

### DISASSEMBLY AND ASSEMBLY

M1233025400025

 APPLY AUTOMATIC  
TRANSMISSION FLUID  
TO ALL MOVING PARTS  
BEFORE INSTALLATION.

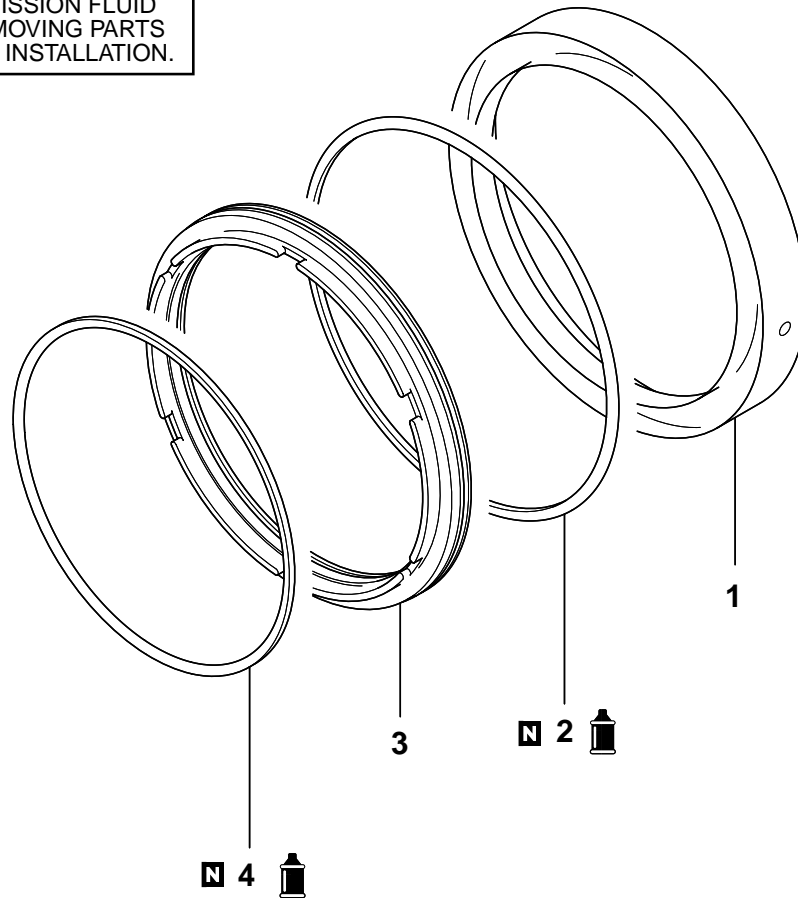

AKX01129AB

#### DISASSEMBLY STEPS

- >>A<< 1. SECOND BRAKE RETAINER  
2. D-RING  
3. SECOND BRAKE PISTON  
>>A<< 4. D-RING

#### ASSEMBLY SERVICE POINT

##### >>A<< D-RING INSTALLATION

Apply ATF or petroleum jelly (Vaseline) to the D-ring, and install carefully.

TSB Revision

## OUTPUT SHAFT

## DISASSEMBLY AND ASSEMBLY

M1233025700026

 APPLY AUTOMATIC TRANSMISSION FLUID TO ALL MOVING PARTS BEFORE INSTALLATION.

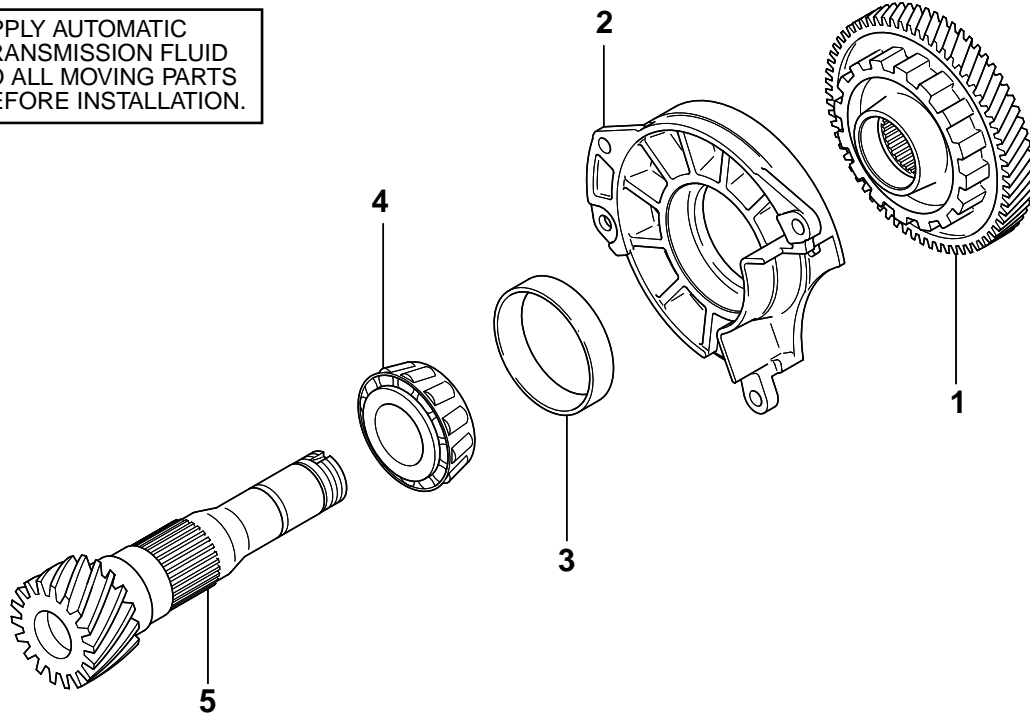

AKX01000AB

- <<A>> >>C<< **DISASSEMBLY STEPS**
1. TRANSFER DRIVEN GEAR
  2. BEARING RETAINER
  - >>B<< 3. OUTER RACE

- <<B>> >>A<< **DISASSEMBLY STEPS (Continued)**
4. TAPER ROLLER BEARING
  5. OUTPUT SHAFT

**Required Special Tools:**

MB990936: Installer Adapter <F4A42>  
 MB990937: Installer Adapter <F4A51>  
 MB990938: Handle  
 MD998801: Bearing Remover  
 MD998812: Installer Cap

MD998813: Installer-100  
 MD998814: Installer-200  
 MD998823: Installer Adapter (48) <F4A42>  
 MD998824: Installer Adapter (50) <F4A51>  
 MD998827: Installer Adapter (56) <F4A51>  
 MD998917: Bearing Remover <F4A42>

TSB Revision
--------------

**DISASSEMBLY SERVICE POINTS**

**<<A>> TRANSFER DRIVEN GEAR REMOVAL**

1. Support the transfer driven gear with general service tool or special tool MD998917(F4A42), and then set them on the press.
2. Push down on the output shaft with the press to remove the transfer driven gear.

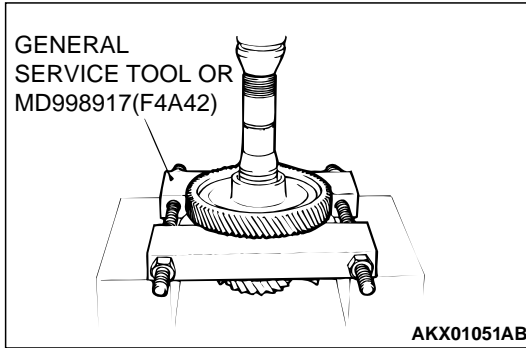

**<<B>> TAPER ROLLER BEARING REMOVAL**

1. Support the taper roller bearing with the special tool MD998801, and then set them on the press.
2. Push down on the output shaft with the press to remove the taper roller bearing.

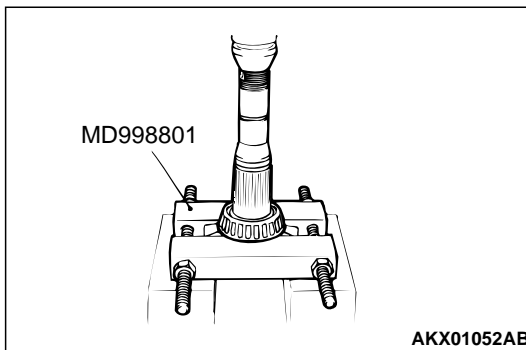

**ASSEMBLY SERVICE POINTS**

**>>A<< TAPER ROLLER BEARING INSTALLATION**

1. Set the output shaft on the press support stand.
2. Using special tools MD998823 <F4A42>, MD998827 <F4A51>, MD998812 and MD998814, press install the taper roller bearing.

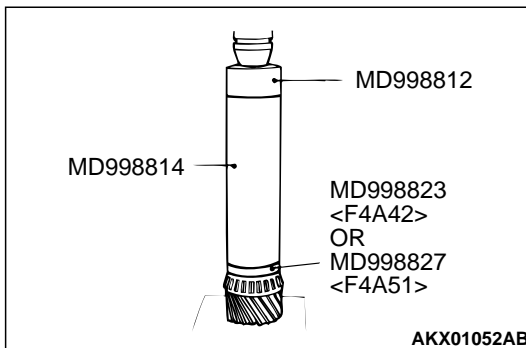

**>>B<< OUTER RACE INSTALLATION**

Use the special tools MB990936 <F4A42>, MB990937 <F4A51> and MB990938 to tap the outer race in the bearing retainer.

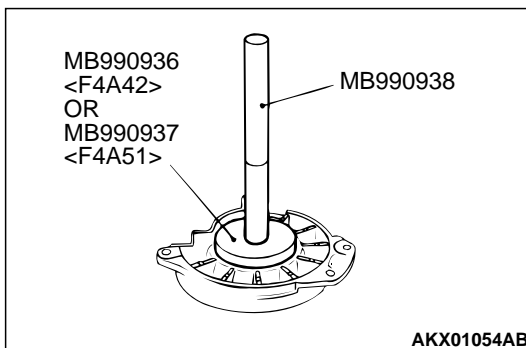

>>C<< TRANSFER DRIVEN GEAR INSTALLATION

1. Set the output shaft on the press support stand.
2. Using special tools MD998823 <F4A42>, MD998824 <F4A51>, MD998812 and MD998813, press install the transfer driven gear.

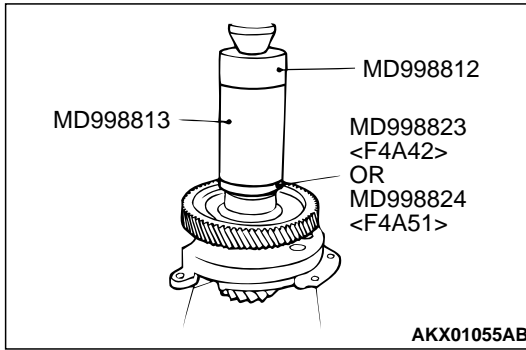

DIFFERENTIAL

DISASSEMBLY AND ASSEMBLY

M1233003100037

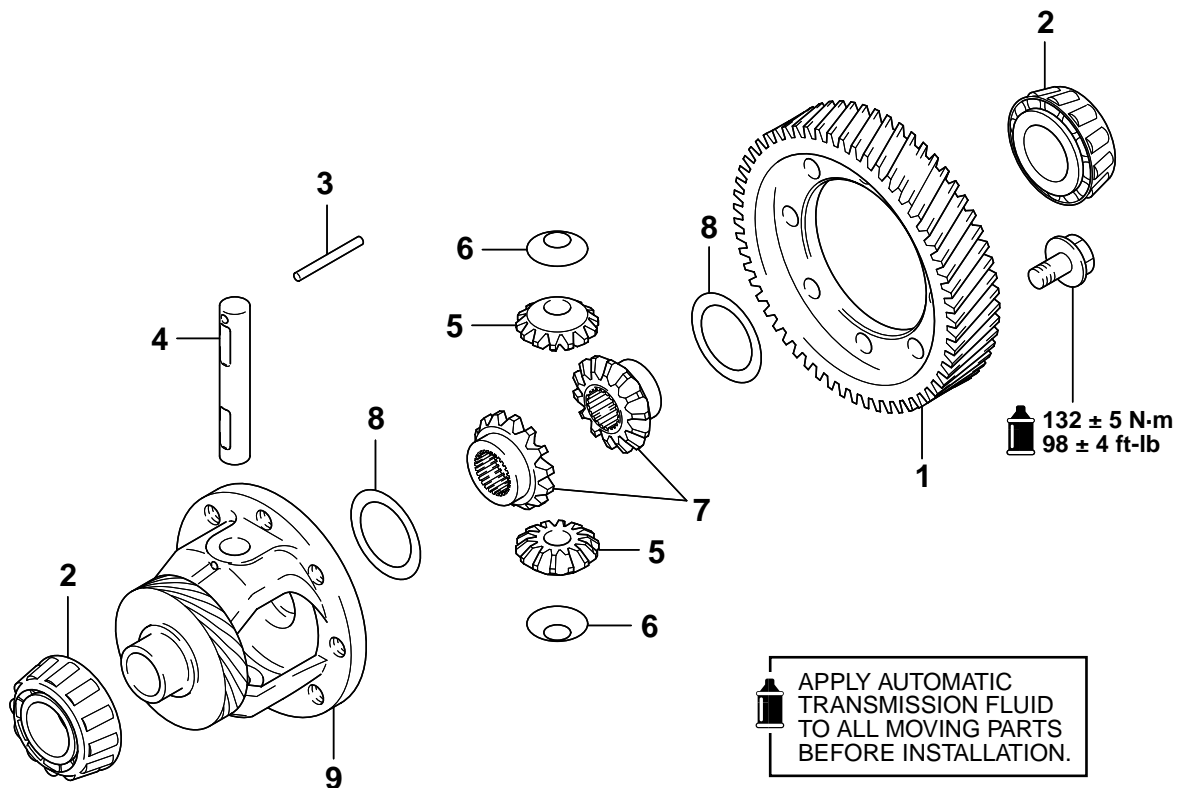

AKX01118AB

DISASSEMBLY STEPS

- <<A>> >>D<< 1. DIFFERENTIAL DRIVE GEAR  
>>C<< 2. TAPER ROLLER BEARINGS

DISASSEMBLY STEPS (Continued)

- >>B<< 3. LOCK PIN  
>>A<< 4. PINION SHAFT  
>>A<< 5. PINIONS

TSB Revision

**DISASSEMBLY STEPS (Continued)**

- >>A<< 6. WASHERS
- >>A<< 7. SIDE GEARS
- >>A<< 8. SPACERS
- 9. DIFFERENTIAL CASE

**Required Special Tools:**

MD998801: Bearing Remover

MD998812: Installer Cap

MD998820: Installer Adapter (42)

**DISASSEMBLY SERVICE POINT**

**<<A>> TAPER ROLLER BEARING REMOVAL**

1. Support the taper roller bearing with special tool MD998801, and then set them on the press.
2. Push down on the differential case with the press to remove the bearing.

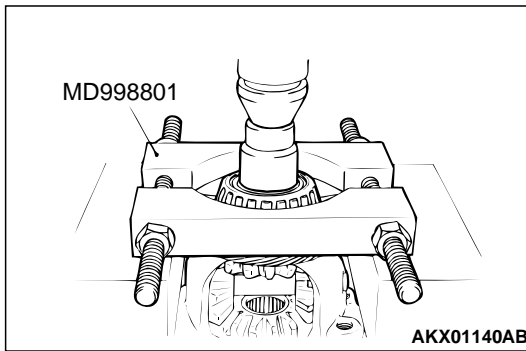

**ASSEMBLY SERVICE POINTS**

**>>A<< SPACER, SIDE GEAR, WASHER, PINION AND PINION SHAFT INSTALLATION**

1. Mount a spacer on the back surface of the side gear, and then install the side gear in the differential case.
 

*NOTE: When a new side gear is to be installed, mount a medium thickness spacer [0.93 to 1.00 mm (0.0366 to 0.0395 inch)].*
2. Set the washer on the back of each pinion, and put both pinions simultaneously in mesh with the side gears. While rotating them, install them into position.

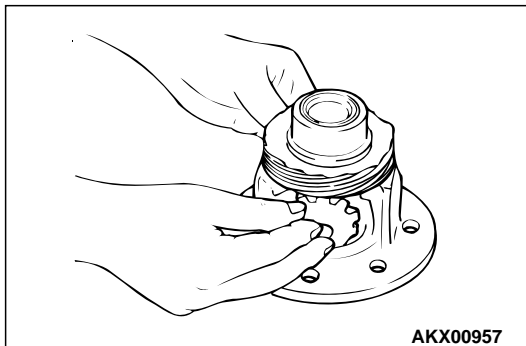

3. Insert the pinion shaft.

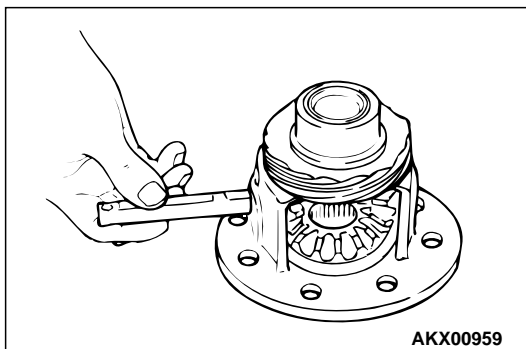

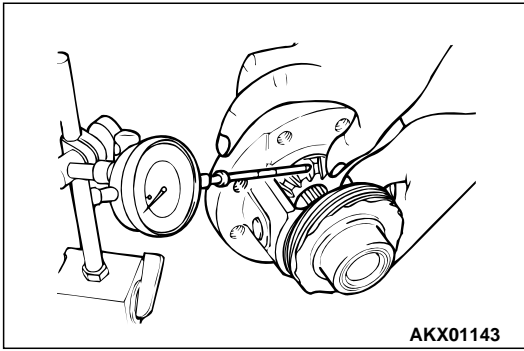

4. Measure the backlash between the side gear and pinion.

**Standard value:**

**0.025 – 0.150 mm (0.0010 - 0.0059 inch)**

5. If the backlash is out of the standard value, select a spacer and re-measure the backlash.

*NOTE: Adjust until the backlashes on both sides are equal.*

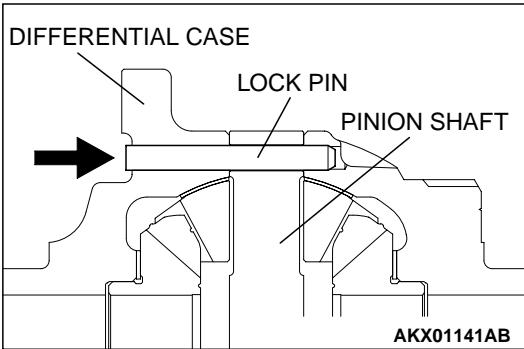

**>>B<< LOCK PIN INSTALLATION**

Install the lock pin so that it will be oriented in the direction shown.

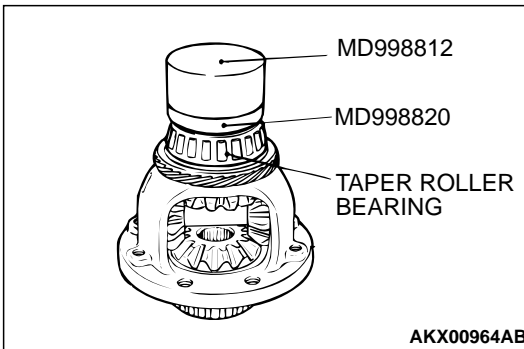

**>>C<< TAPER ROLLER BEARING INSTALLATION**

Using special tools MD998812 and MD998820, press install the taper roller bearing with the press.

>>D<< DIFFERENTIAL DRIVE GEAR INSTALLATION

Apply ATF to the bolt, and then tighten the bolts to the specified torque in the shown sequence.

**Tightening torque:  $132 \pm 5$  N·m ( $98 \pm 4$  ft-lb)**

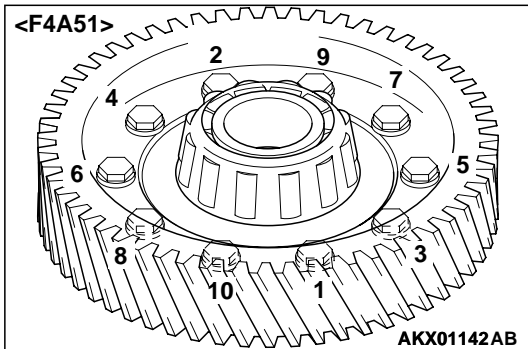
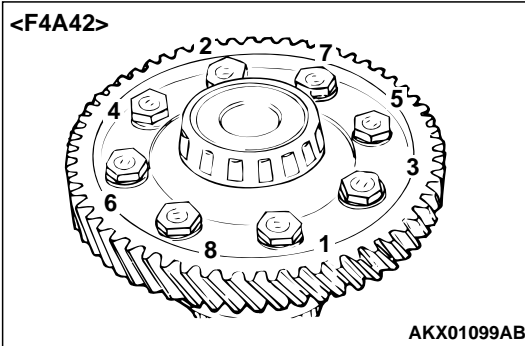

# VALVE BODY

## DISASSEMBLY AND ASSEMBLY

M1233005500031

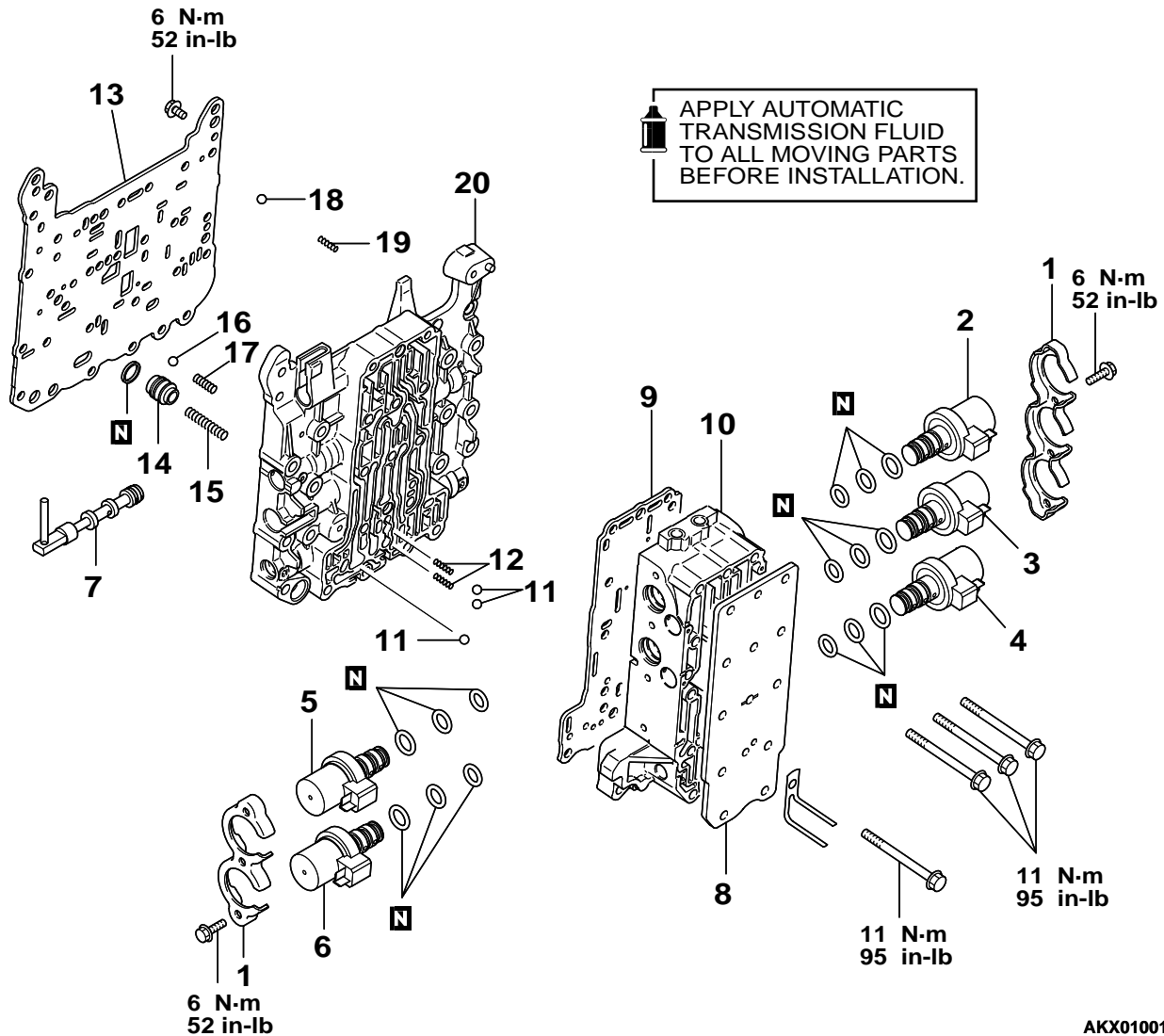

AKX01001AC

### DISASSEMBLY STEPS

- |       |       |   |
|-------|-------|---|
| <<A>> | >>C<< | 1. SOLENOID VALVE SUPPORT                         |
| <<A>> | >>C<< | 2. UNDERDRIVE SOLENOID VALVE                      |
| <<A>> | >>C<< | 3. SECOND SOLENOID VALVE                          |
| <<A>> | >>C<< | 4. TORQUE CONVERTER CLUTCH CONTROL SOLENOID VALVE |
| <<A>> | >>C<< | 5. OVERDRIVE SOLENOID VALVE                       |
| <<A>> | >>C<< | 6. LOW-REVERSE SOLENOID VALVE                     |
|       |       | 7. MANUAL VALVE                                   |
|       |       | 8. COVER  |
|       |       | 9. PLATE  |
|       |       | 10. OUTSIDE VALVE BODY ASSEMBLY                   |

### DISASSEMBLY STEPS (Continued)

- |       |                                     |
|-------|-------------------------------------|
| >>B<< | 11. STEEL BALL (ORIFICE CHECK BALL) |
| >>B<< | 12. SPRING                          |
| >>A<< | 13. PLATE                           |
| >>A<< | 14. DAMPING VALVE                   |
| >>A<< | 15. DAMPING VALVE SPRING            |
| >>A<< | 16. STEEL BALL (LINE RELIEF)        |
| >>A<< | 17. SPRING                          |
| >>A<< | 18. STEEL BALL (ORIFICE CHECK BALL) |
| >>A<< | 19. SPRING                          |
|       | 20. INSIDE VALVE BODY ASSEMBLY      |

TSB Revision



 APPLY AUTOMATIC TRANSMISSION FLUID TO ALL MOVING PARTS BEFORE INSTALLATION.

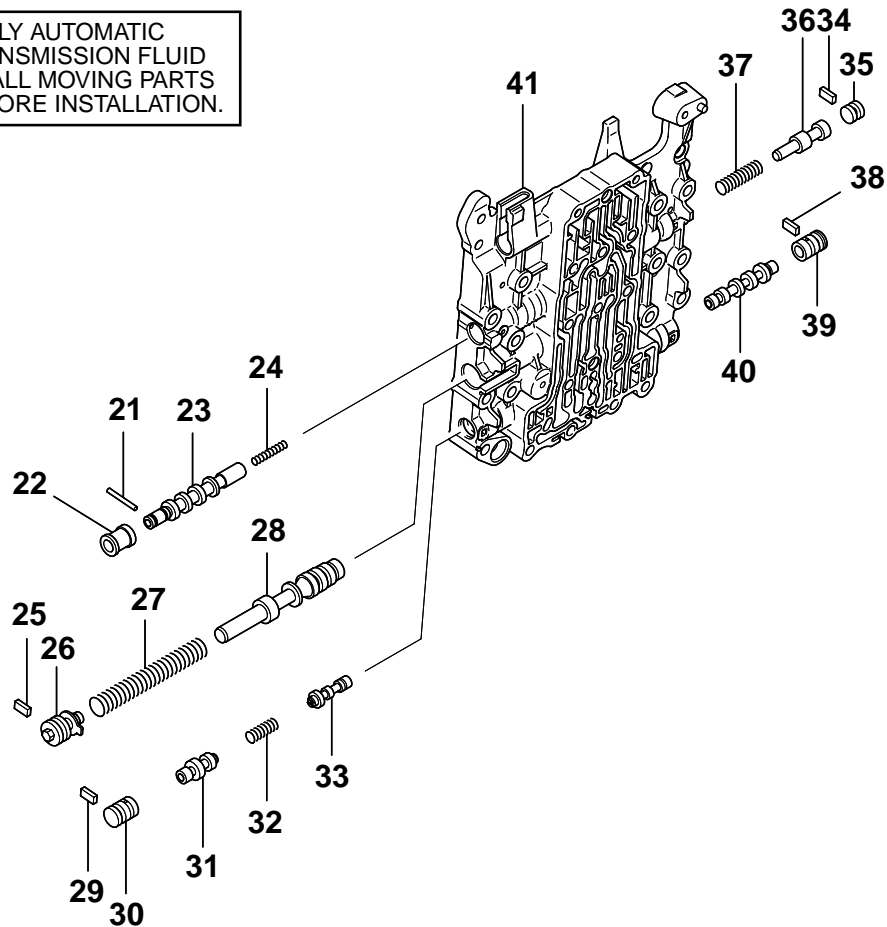

AKX01091AB

- |   |   |
|---|---|
| <ul style="list-style-type: none"> <li>21. ROLLER</li> <li>22. TORQUE CONVERTER CLUTCH CONTROL VALVE SLEEVE</li> <li>23. TORQUE CONVERTER CLUTCH CONTROL VALVE</li> <li>24. TORQUE CONVERTER CLUTCH CONTROL VALVE SPRING</li> <li>25. PLATE</li> <li>26. SCREW</li> <li>27. REGULATOR VALVE SPRING</li> <li>28. REGULATOR VALVE</li> <li>29. PLATE</li> </ul> | <ul style="list-style-type: none"> <li>30. FAIL-SAFE VALVE A SLEEVE</li> <li>31. FAIL-SAFE VALVE A2</li> <li>32. FAIL-SAFE VALVE A SPRING</li> <li>33. FAIL-SAFE VALVE A1</li> <li>34. PLATE</li> <li>35. PLUG</li> <li>36. TORQUE CONVERTER VALVE</li> <li>37. TORQUE CONVERTER VALVE SPRING</li> <li>38. PLATE</li> <li>39. FAIL-SAFE VALVE B SLEEVE</li> <li>40. FAIL-SAFE VALVE B</li> <li>41. INSIDE VALVE BODY</li> </ul> |
|---|---|

 APPLY AUTOMATIC TRANSMISSION FLUID TO ALL MOVING PARTS BEFORE INSTALLATION.

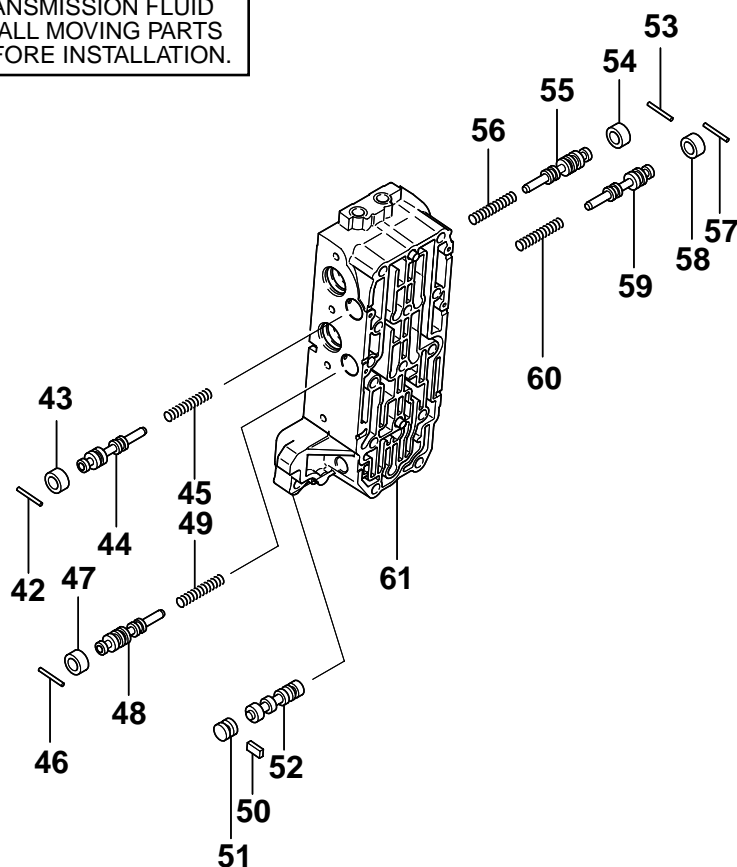

AKX01092AB

- |   |  |
|---|--|
| 42. ROLLER                                    | 52. SWITCHING VALVE                          |
| 43. OVERDRIVE PRESSURE CONTROL VALVE SLEEVE   | 53. ROLLER                                   |
| 44. OVERDRIVE PRESSURE CONTROL VALVE          | 54. UNDERDRIVE PRESSURE CONTROL VALVE SLEEVE |
| 45. OVERDRIVE PRESSURE CONTROL VALVE SPRING   | 55. UNDERDRIVE PRESSURE CONTROL VALVE        |
| 46. ROLLER                                    | 56. UNDERDRIVE PRESSURE CONTROL VALVE SPRING |
| 47. LOW-REVERSE PRESSURE CONTROL VALVE SLEEVE | 57. ROLLER                                   |
| 48. LOW-REVERSE PRESSURE CONTROL VALVE        | 58. SECOND PRESSURE CONTROL VALVE SLEEVE     |
| 49. LOW-REVERSE PRESSURE CONTROL VALVE SPRING | 59. SECOND PRESSURE CONTROL VALVE            |
| 50. PLATE                                     | 60. SECOND PRESSURE CONTROL VALVE SPRING     |
| 51. PLUG                                      | 61. OUTSIDE VALVE BODY                       |

**DISASSEMBLY SERVICE POINT**

**<<A>> SOLENOID VALVES REMOVAL**

Mark the solenoid valves with white paint to make assembly easier.

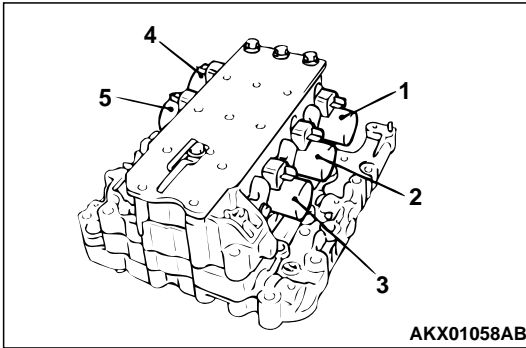

**ASSEMBLY SERVICE POINTS**

**>>A<< SPRING, STEEL BALL, DAMPING VALVE AND DAMPING VALVE SPRING INSTALLATION**

1. Install the two steel balls and two springs to the inside valve body as shown.
2. Install the damping valve and spring to the inside valve body as shown.

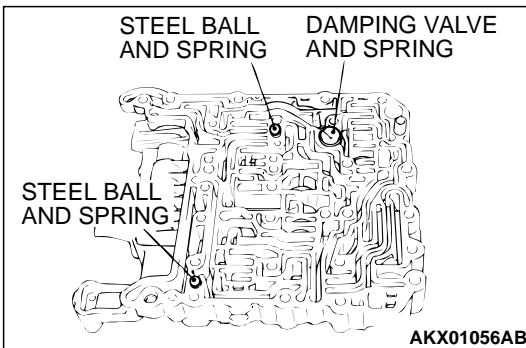

**>>B<< SPRING AND STEEL BALL INSTALLATION**

Install the three steel balls and two springs to the inside valve body as shown.

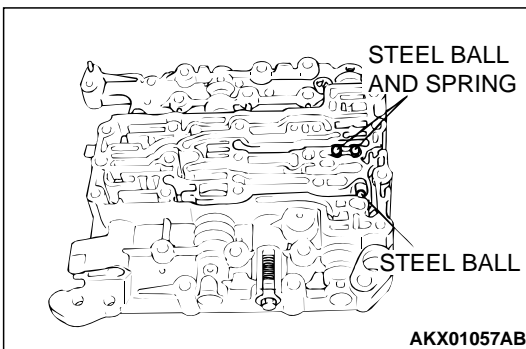

**>>C<< SOLENOID VALVES INSTALLATION**

1. Apply ATF or petroleum jelly (Vaseline) to the O-ring and install carefully.
2. Install the solenoid valves by referring to the marks applied during disassembly.

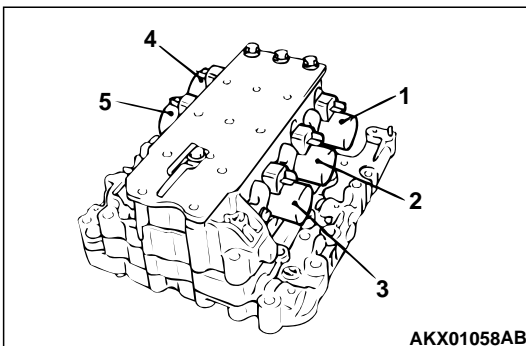

NO.	NAME
1	Underdrive solenoid valve
2	Second solenoid valve

NO.	NAME
3	Torque converter clutch control solenoid valve
4	Overdrive solenoid valve
5	Low-reverse solenoid valve

## SPEEDOMETER GEAR

### DISASSEMBLY AND ASSEMBLY

M1233004000022

 APPLY AUTOMATIC TRANSMISSION FLUID TO ALL MOVING PARTS BEFORE INSTALLATION.

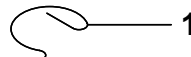
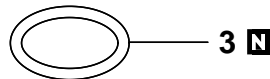
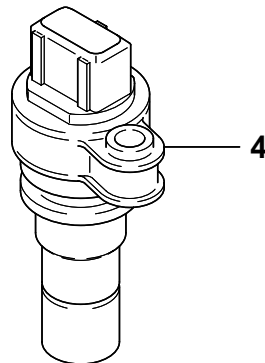
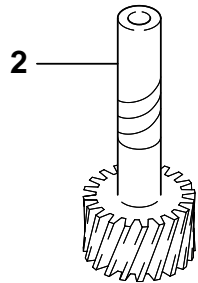

AKX00965AB

#### DISASSEMBLY STEPS

1. E-CLIP
2. SPEEDOMETER DRIVEN GEAR

#### DISASSEMBLY STEPS (Continued)

3. O-RING
4. SLEEVE

# DRIVE SHAFT OIL SEAL

## DISASSEMBLY AND ASSEMBLY

M1233004300023

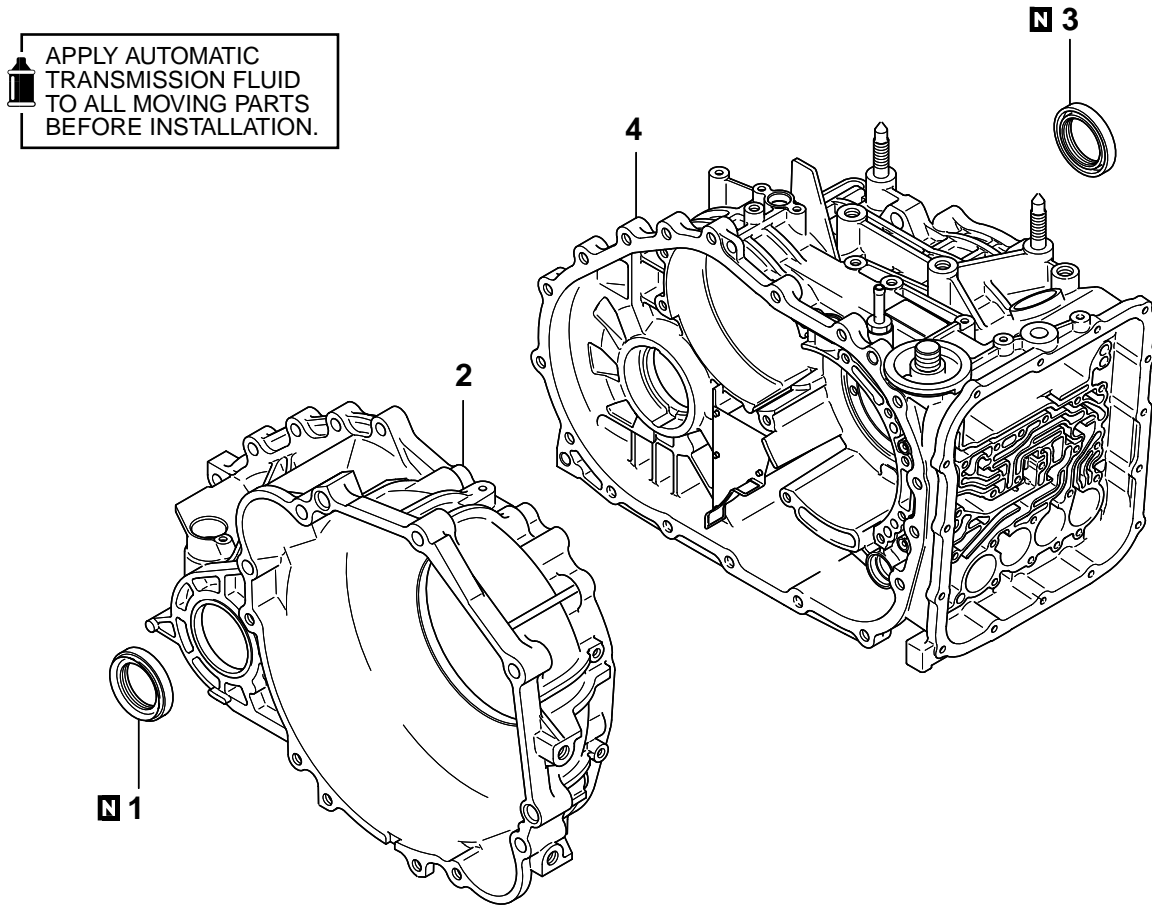

AKX01002AB

### DISASSEMBLY STEPS

- >>A<<
1. OIL SEAL
  2. TORQUE CONVERTER HOUSING

### DISASSEMBLY STEPS (Continued)

- >>B<<
3. OIL SEAL
  4. TRANSAXLE CASE

**Required Special Tool:**  
MD998800: Oil Seal Installer

TSB Revision

**ASSEMBLY SERVICE POINTS****>>A<< OIL SEAL INSTALLATION**

Use special tool MD998800 to tap the oil seal into the torque converter housing.

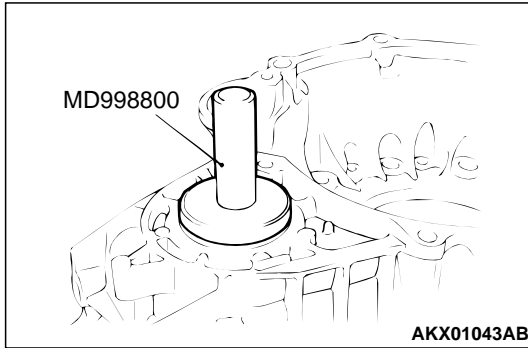
**>>B<< OIL SEAL INSTALLATION**

Use special tool MD998800 to tap the oil seal in the transaxle case.

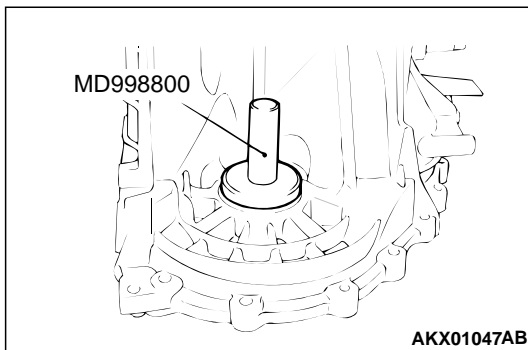

## SPECIFICATIONS

### FASTENER TIGHTENING SPECIFICATIONS

M1233023100062

ITEMS		SPECIFICATIONS
Transaxle	Control cable bracket	23 N·m (17 ft-lb)
	Eye bolt	30 N·m (22 ft-lb)
	Fluid temperature sensor	11 N·m (95 in-lb)
	Input shaft speed sensor	11 N·m (95 in-lb)
	Manual control lever	22 N·m (16 ft-lb)
	Manual control shaft detent	6 N·m (52 in-lb)
	Oil filter	12 N·m (104 in-lb)
	Oil pump	23 N·m (17 ft-lb)
	Output shaft bearing retainer <F4A42>	23 N·m (17 ft-lb)
	Output shaft bearing retainer<F4A51>	54 N·m (40 ft-lb)
	Output shaft jam nut	167 N·m (123 ft-lb)
	Output shaft speed sensor	11 N·m (95 in-lb)
	Park/neutral position switch (PNP switch)	11 N·m (95 in-lb)
	Rear cover	23 N·m (17 ft-lb)
	Roll stopper bracket	69 N·m (51 ft-lb)
	Speedometer gear	5 N·m (43 in-lb)
	Torque converter housing	48 N·m (35 ft-lb)
	Transfer drive gear	34 N·m (25 ft-lb)
	Valve body cover	11 N·m (95 in-lb)
	Valve body mounting bolt	11 N·m (95 in-lb)
Wiring harness bracket	23 N·m (17ft-lb)	
Components	Differential drive gear	132 N·m (98 ft-lb)
	Plate	6 N·m (52 in-lb)
	Solenoid valve support	6 N·m (52 in-lb)
	Valve body	11 N·m (95 in-lb)

### GENERAL SPECIFICATIONS

M1233000200046

ITEMS		SPECIFICATIONS	
Model		F4A42	F4A51
Type		Electronically controlled 4-speed full-automatic	
Torque converter	Type	3-element with torque converter clutch	
	Engine stall speed	2100 – 2600 r/min	2100 – 2600 r/min
	Stall torque ratio	2.0	2.0

TSB Revision

ITEMS		SPECIFICATIONS	
Gear ratio	1st	2.842	2.842
	2nd	1.529	1.495
	3rd	1.000	1.000
	4th	0.712	0.731
	Reverse	2.480	2.720
Final gear ratio		4.042	3.735
Speedometer gear ratio (driven/drive)		29/36	29/36

**SERVICE SPECIFICATIONS**

M1233000300032

ITEMS		STANDARD VALUE
Output shaft preload mm (in)		0.01 – 0.09 (0.0004 – 0.0035)
Brake reaction plate end play mm (in)		0 – 0.16 (0 – 0.0063)
Low-reverse brake end play mm (in)		1.65 – 2.11 (0.050 – 0.0831)
Second brake end play mm (in)	F4A42	0.79 – 1.25 (0.0311 – 0.0492)
	F4A51	1.09 – 1.55 (0.0429 – 0.0610)
Underdrive sun gear end play mm (in)		0.25 – 0.45 (0.0098 – 0.0177)
Input shaft end play mm (in)		0.70 – 1.45 (0.028 – 0.057)
Differential case preload mm (in)		0.045 – 0.105 (0.0018 – 0.0041)
Underdrive clutch end play mm (in)		1.6 – 1.8 (0.0630 – 0.0709)
Reverse and overdrive clutch return spring retainer end play mm (in)		0 – 0.09 (0 – 0.0035)
Overdrive clutch end play mm (in)		1.6 – 1.8 (0.0630 – 0.0709)
Reverse clutch end play mm (in)		1.5 – 1.7 (0.0591 – 0.0669)
Backlash between differential side gear and pinion mm (in)		0.025 – 0.150 (0.0010 – 0.0059)

**VALVE BODY SPRING IDENTIFICATION TABLE**

M1233022900032

SPRING	WIRE DIAMETER mm (in)	OUTSIDE DIAMETER mm (in)	FREE LENGTH mm (in)	NUMBER OF LOOPS
Regulator valve spring	1.8 (0.071)	15.7 (0.618)	86.7 (3.413)	24
Underdrive pressure control valve spring	0.7 (0.028)	7.6 (0.299)	37.7 (1.484)	25
Overdrive pressure control valve spring	0.7 (0.028)	7.6 (0.299)	37.7 (1.484)	25
Low-reverse pressure control valve spring	0.7 (0.028)	7.6 (0.299)	37.7 (1.484)	25
Second pressure control valve spring	0.7 (0.028)	7.6 (0.299)	37.7 (1.484)	25
Torque converter spring	1.6 (0.063)	11.2 (0.441)	34.4 (1.354)	12.5
Torque converter clutch control valve spring	0.7 (0.028)	5.9 (0.232)	28.1 (1.106)	19
Fail-safe valve spring	0.7 (0.028)	8.9 (0.350)	21.9 (0.862)	9.5



<b>SPRING</b>	<b>WIRE DIAMETER mm (in)</b>	<b>OUTSIDE DIAMETER mm (in)</b>	<b>FREE LENGTH mm (in)</b>	<b>NUMBER OF LOOPS</b>
Damping valve spring	1.0 (0.039)	7.7 (0.303)	35.8 (1.409)	17
Line relief valve spring	1.0 (0.039)	7.0 (0.276)	17.3 (0.681)	10
Orifice check ball spring	0.5 (0.020)	4.5 (0.177)	17.2 (0.677)	15

**SNAP RING, SPACER, THRUST WASHER, THRUST RACE AND PRESSURE PLATE  
FOR ADJUSTMENT**

M1233023000032

**Thrust washer (For adjustment of input shaft end  
play)**

<b>THICKNESS mm (in)</b>	<b>IDENTIFICATION SYMBOL</b>	<b>PART NO.</b>	<b>THICKNESS mm (in)</b>	<b>IDENTIFICATION SYMBOL</b>	<b>PART NO.</b>
1.8 (0.071)	18	MD754509	2.4 (0.094)	24	MD753793
2.0 (0.079)	20	MD754508	2.6 (0.102)	26	MD753794
2.2 (0.087)	22	MD754507	2.8 (0.110)	28	MD753795

**Snap ring <F4A42> (For adjustment of  
underdrive clutch and overdrive clutch end  
plays)**

<b>THICKNESS mm (in)</b>	<b>IDENTIFICATION SYMBOL</b>	<b>PART NO.</b>	<b>THICKNESS mm (in)</b>	<b>IDENTIFICATION SYMBOL</b>	<b>PART NO.</b>
1.6 (0.063)	None	MD759666	2.4 (0.094)	Brown	MD752129
1.7 (0.067)	Blue	MD759667	2.5 (0.098)	None	MD752130
1.8 (0.071)	Brown	MD759668	2.6 (0.102)	Blue	MD752131
1.9 (0.075)	None	MD752124	2.7 (0.106)	Brown	MD752132
2.0 (0.079)	Blue	MD752125	2.8 (0.110)	None	MD752133
2.1 (0.083)	Brown	MD752126	2.9 (0.114)	Blue	MD752134
2.2 (0.087)	None	MD752127	3.0 (0.118)	Brown	MD754680
2.3 (0.091)	Blue	MD752128			

**Snap ring <F4A51>  
(For adjustment of underdrive clutch and  
overdrive clutch end plays)**

<b>THICKNESS mm (in)</b>	<b>IDENTIFICATION SYMBOL</b>	<b>PART NO.</b>	<b>THICKNESS mm (in)</b>	<b>IDENTIFICATION SYMBOL</b>	<b>PART NO.</b>
1.6 (0.063)	Brown	MD759960	2.4 (0.094)	Blue	MD750845
1.7 (0.067)	None	MD759961	2.5 (0.098)	Brown	MD750846
1.8 (0.071)	Blue	MD759962	2.6 (0.102)	None	MD750847
1.9 (0.075)	Brown	MD759963	2.7 (0.106)	Blue	MD750848
2.0 (0.079)	None	MD750841	2.8 (0.110)	Brown	MD750849
2.1 (0.083)	Blue	MD750842	2.9 (0.114)	None	MD750850
2.2 (0.087)	Brow	MD750843	3.0 (0.118)	Blue	MD750851
2.3 (0.091)	None	MD750844			

Snap ring <F4A42>(For adjustment of low-reverse brake and second brake reaction plates end plays)

THICKNESS mm (in)	IDENTIFICATION SYMBOL	PART NO.	THICKNESS mm (in)	IDENTIFICATION SYMBOL	PART NO.
2.2 (0.087)	Blue	MD754786	2.4 (0.094)	None	MD758240
2.3 (0.091)	Brown	MD754787	2.5 (0.098)	Blue	MD758241

Snap ring <F4A51>(For adjustment of low-reverse brake and second brake reaction plates end plays)

THICKNESS mm (in)	IDENTIFICATION SYMBOL	PART NO.	THICKNESS mm (in)	IDENTIFICATION SYMBOL	PART NO.
2.2 (0.087)	None	MD756784	2.4 (0.094)	Brown	MD758552
2.3 (0.091)	Blue	MD756785	2.5 (0.098)	None	MD758553

Pressure plate <F4A42>(For adjustment of low-reverse brake and second brake end plays)

THICKNESS mm (in)	IDENTIFICATION SYMBOL	PART NO.	THICKNESS mm (in)	IDENTIFICATION SYMBOL	PART NO.
1.6 (0.063)	L	MD759567	2.4 (0.094)	4	MD759417
1.8 (0.071)	1	MD759414	2.6 (0.102)	6	MD759418
2.0 (0.079)	0	MD759415	2.8 (0.110)	8	MD759419
2.2 (0.087)	2	MD759416	3.0 (0.118)	D	MD759420

Pressure plate <F4A51>(For adjustment of low-reverse brake and second brake end plays)

THICKNESS mm (in)	IDENTIFICATION SYMBOL	PART NO.	THICKNESS mm (in)	IDENTIFICATION SYMBOL	PART NO.
1.6 (0.063)	F	MD759568	2.4 (0.094)	B	MD759428
1.8 (0.071)	E	MD759425	2.6 (0.102)	A	MD759429
2.0 (0.079)	D	MD759426	2.8 (0.110)	0	MD759430
2.2 (0.087)	C	MD759427	3.0 (0.118)	1	MD759431

Snap ring <F4A42>(For adjustment of reverse clutch end play)

THICKNESS mm (in)	IDENTIFICATION SYMBOL	PART NO.	THICKNESS mm (in)	IDENTIFICATION SYMBOL	PART NO.
1.6 (0.063)	None	MD761085	2.3 (0.091)	Blue	MD752141
1.7 (0.067)	Blue	MD761086	2.4 (0.094)	Brown	MD752142
1.8 (0.071)	Brown	MD761087	2.5 (0.098)	None	MD752143
1.9 (0.075)	None	MD752137	2.6 (0.102)	Blue	MD752144
2.0 (0.079)	Blue	MD752138	2.7 (0.106)	Brown	MD752145
2.1 (0.083)	Brown	MD752139	2.8 (0.110)	None	MD752146
2.2 (0.087)	None	MD752140			

**Snap ring <F4A51>(For adjustment of reverse clutch end play)**

THICKNESS mm (in)	IDENTIFICATION SYMBOL	PART NO.	THICKNESS mm (in)	IDENTIFICATION SYMBOL	PART NO.
1.6 (0.063)	None	MD761008	2.3 (0.091)	Blue	MD756693
1.7 (0.067)	Blue	MD761089	2.4 (0.094)	Brown	MD756694
1.8 (0.071)	Brown	MD761090	2.5 (0.098)	None	MD756695
1.9 (0.075)	None	MD758947	2.6 (0.102)	Blue	MD756696
2.0 (0.079)	Blue	MD756690	2.7 (0.106)	Brown	MD756697
2.1 (0.083)	Brown	MD756691	2.8 (0.110)	None	MD756698
2.2 (0.087)	None	MD756692			

**Snap ring(For adjustment of reverse clutch and overdrive clutch spring retainer end plays)**

THICKNESS mm (in)	IDENTIFICATION SYMBOL	PART NO.	THICKNESS mm (in)	IDENTIFICATION SYMBOL	PART NO.
1.48 (0.0583)	Brown	MD755600	1.58 (0.0622)	Blue	MD755602
1.53 (0.0602)	None	MD755601	1.63 (0.0642)	Brown	MD755603

**Thrust race(For adjustment of underdrive sun gear end play)**

THICKNESS mm (in)	IDENTIFICATION SYMBOL	PART NO.	THICKNESS mm (in)	IDENTIFICATION SYMBOL	PART NO.
1.6 (0.063)	-	MD707267	2.2 (0.087)	-	MD723065
1.7 (0.067)	-	MD759681	2.3 (0.091)	-	MD754796
1.8 (0.071)	-	MD723064	2.4 (0.094)	-	MD724358
1.9 (0.075)	-	MD754794	2.5 (0.098)	-	MD754797
2.0 (0.079)	-	MD707268	2.6 (0.102)	-	MD754798
2.1 (0.083)	-	MD754795			

**Spacer (For adjustment of output shaft preload)**

THICKNESS mm (in)	IDENTIFICATION SYMBOL	PART NO.	THICKNESS mm (in)	IDENTIFICATION SYMBOL	PART NO.
1.88 (0.0740)	88	MD756579	2.36 (0.0929)	36	MD756591
1.92 (0.0756)	92	MD756580	2.40 (0.0945)	40	MD756592
1.96 (0.0772)	96	MD756581	2.44 (0.0961)	44	MD756593
2.00 (0.0787)	00	MD756582	2.48 (0.0976)	48	MD756594
2.04 (0.0803)	04	MD756583	2.52 (0.0992)	52	MD756595
2.08 (0.0819)	08	MD756584	2.56 (0.1008)	56	MD756596
2.12 (0.0835)	12	MD756585	2.60 (0.1024)	60	MD756597
2.16 (0.0850)	16	MD756586	2.64 (0.1039)	64	MD756598
2.20 (0.0866)	20	MD756587	2.68 (0.1055)	68	MD756599
2.24 (0.0882)	24	MD756588	2.72 (0.1071)	72	MD760685
2.28 (0.0898)	28	MD756589	2.76 (0.1087)	76	MD760686
2.32 (0.0913)	32	MD756590			

**Spacer (For adjustment of differential case preload)**

THICKNESS mm (in)	IDENTIFICATION SYMBOL	PART NO.	THICKNESS mm (in)	IDENTIFICATION SYMBOL	PART NO.
0.71 (0.0280)	71	MD754475	1.07 (0.0421)	07	MD720945
0.74 (0.0291)	74	MD727660	1.10 (0.0433)	J	MD710454
0.77 (0.0303)	77	MD754476	1.13 (0.0445)	D	MD700270
0.80 (0.0315)	80	MD727661	1.16 (0.0457)	K	MD710455
0.83 (0.0327)	83	MD720937	1.19 (0.0469)	L	MD710456
0.86 (0.0339)	86	MD720938	1.22 (0.0480)	G	MD700271
0.89 (0.0350)	89	MD720939	1.25 (0.0492)	M	MD710457
0.92 (0.0362)	92	MD720940	1.28 (0.0504)	N	MD710458
0.95 (0.0374)	95	MD720941	1.31 (0.0516)	E	MD706574
0.98 (0.0386)	98	MD720942	1.34 (0.0528)	O	MD710459
1.01 (0.0398)	01	MD720943	1.37 (0.0539)	P	MD710460
1.04 (0.0409)	04	MD720944			

**Spacer (For adjustment of backlash between differential side gear and pinion)**

THICKNESS mm (in)	IDENTIFICATION SYMBOL	PART NO.	THICKNESS mm (in)	IDENTIFICATION SYMBOL	PART NO.
0.75 – 0.82 (0.0295 – 0.0323)	-	MD722986	1.01 – 1.08 (0.0398 – 0.0425)	-	MD722982
0.83 – 0.92 (0.0327 – 0.0362)	-	MD722985	1.09 – 1.16 (0.0429 – 0.0457)	-	MD722983
0.93 – 1.00 (0.0366 – 0.0394)	-	MD722984			

**SEALANTS**

M1233000500036

ITEMS	SPECIFIED SEALANT
Rear cover	mitsubishi genuine sealant Part No. MD974421 or equivalent
Torque converter housing	mitsubishi genuine sealant Part No. MD974421 or equivalent
Valve body cover	mitsubishi genuine sealant Part No. MD974421 or equivalent