

GROUP 36

PARKING BRAKES

CONTENTS

GENERAL DESCRIPTION	36-2	PARKING BRAKE CABLE	36-7
PARKING BRAKE DIAGNOSIS	36-2	REMOVAL AND INSTALLATION <DRUM BRAKE>	
INTRODUCTION TO PARKING BRAKES DIAGNOSIS		36-7
.....	36-2	PARKING BRAKE CABLE	36-8
PARKING BRAKES DIAGNOSIS		REMOVAL AND INSTALLATION <DRUM-IN-DISC	
TROUBLESHOOTING STRATEGY	36-2	BRAKE>	36-8
SYMPTOM CHART	36-2	PARKING BRAKE LINING AND DRUM	
SYMPTOM PROCEDURES	36-3	36-11
ON-VEHICLE SERVICE	36-4	REMOVAL AND INSTALLATION	36-11
PARKING BRAKE LEVER STROKE CHECK AND		BRAKE LINING AND BRAKE DRUM CHECK	
ADJUSTMENT	36-4	36-12
PARKING BRAKE SWITCH CHECK	36-5	SPECIFICATIONS	36-12
LINING RUNNING-IN	36-5	FASTENER TIGHTENING SPECIFICATIONS	
PARKING BRAKE LEVER	36-6	36-12
REMOVAL AND INSTALLATION	36-6	SERVICE SPECIFICATIONS	36-12
		LUBRICANTS	36-12

GENERAL DESCRIPTION

M1361000100065

The parking brake is of a mechanical control type acting on the rear wheels. A lever is used to apply the parking brake.

The operation method utilizes a parking brake lever which is in an offset position at the driver's side.

CONSTRUCTION DIAGRAM

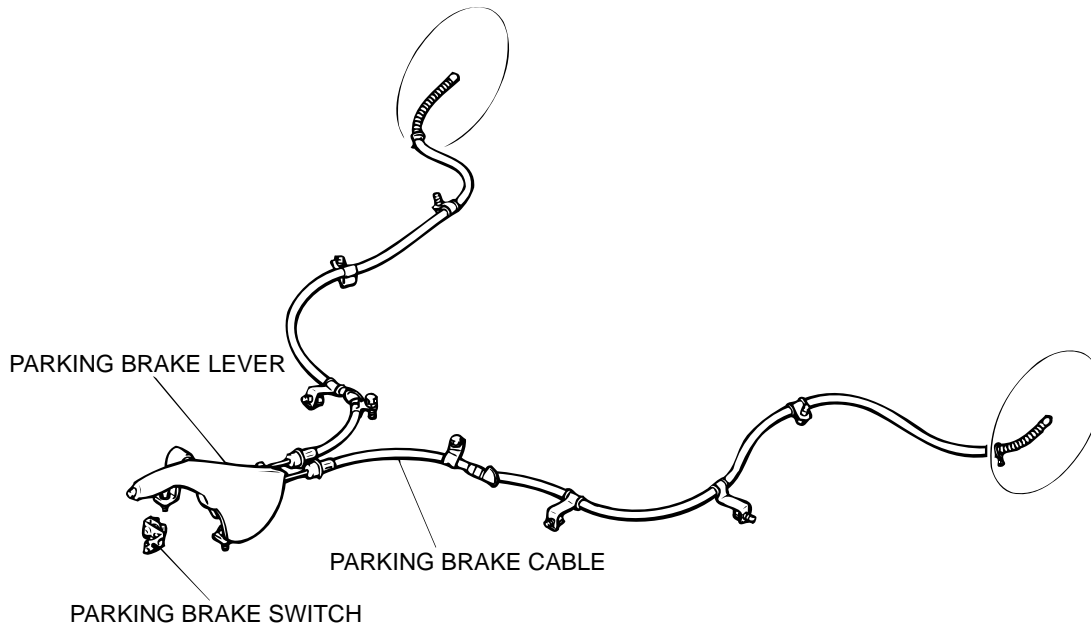

AC000811AB

PARKING BRAKE DIAGNOSIS

INTRODUCTION TO PARKING BRAKES DIAGNOSIS

M1361003700066

If the parking brake is faulty, parking brake effort will become insufficient.

The cause will malfunction of parking brake parts and parking brake lever out of adjustment.

PARKING BRAKES DIAGNOSIS TROUBLESHOOTING STRATEGY

M1361003800063

Use these steps to plan your diagnostic strategy. If you follow them carefully, you will be sure that you have exhausted most of the possible ways to find a parking brakes fault.

1. Gather Information from the customer.

2. Verify that the condition described by the customer exists.
3. Find the malfunction by following the Symptom Chart.
4. Verify malfunction is eliminated.

SYMPTOM CHART

M1361004100067

SYMPTOMS	INSPECTION PROCEDURE	REFERENCE PAGE
Brake drag	1	P.36-3
Insufficient parking brake function	2	P.36-3

TSB Revision

SYMPTOM PROCEDURES

Inspection Procedure 1: Brake drag

DIAGNOSIS

STEP 1. Check the incomplete release of parking brake.

Q: Is there a fault?

YES : Correct it. Then go to Step 5.

NO : Go to step 2.

STEP 2. Check the incorrect parking break adjustment. (Refer to P.36-4.)

Q: Is there a fault?

YES : Adjust it. Then go to Step 5.

NO : Go to Step 3.

STEP 3. Check the parking break cable routing condition.

Q: Is there a fault?

YES : Correct it. Then go to Step 5.

NO : Go to Step 4.

STEP 4. Check the rear brake's shoe and lining. (Refer to P.36-5.)

Q: Is there a fault?

YES : Correct it. Then go to Step 5.

NO : Go to Step 5.

STEP 5. Check symptom.

Q: Is the malfunction eliminated?

YES : Diagnosis is complete.

NO : Recheck from Step 1.

Inspection Procedure 2: Insufficient parking brake function

DIAGNOSIS

STEP 1. Check the excessive parking brake lever stroke.

Q: Is there a fault?

YES : Adjust the parking brake lever stroke or check the parking brake cable routing. Then go to Step 7.

NO : Go to Step 2.

STEP 2. Check the parking brake cable sticking.

Q: Is there a fault?

YES : Replace it. Then go to Step 7.

NO : Go to Step 3.

STEP 3. Check the worn brake lining.

Q: Is there a fault?

YES : Replace it. Then go to Step 7.

NO : Go to Step 4.

STEP 4. Check the grease or oil on lining surface.

Q: Is there a fault?

YES : Replace it. Then go to Step 7.

NO : Go to Step 5 (Vehicles with drum brake). Go to Step 7 (Vehicles with drum-in-disc brake)

STEP 5. Check the stuck wheel cylinder.

Q: Is there a fault?

YES : Replace it. Then go to Step 7.

NO : Go to Step 6.

STEP 6. Check the auto adjuster malfunction.

Q: Is there a fault?

YES : Replace it. Then go to Step 7.

NO : Go to Step 7.

STEP 7. Check symptom.

Q: Is the malfunction eliminated?

YES : Diagnosis is complete.

NO : Recheck from Step 1.

ON-VEHICLE SERVICE

PARKING BRAKE LEVER STROKE CHECK AND
ADJUSTMENT

M1361000900050

1. Pull the parking brake lever with a force of approximately 196 N (44 pounds) and count the number of notches.

Standard value:**5 – 7 notches <Vehicles with drum brake>****3 – 5 notches <Vehicles with drum-in-disc brake>**

NOTE: Depressing the brake pedal repeatedly will automatically adjust the shoe clearance to the normal setting.

2. If the parking brake lever stroke is not the standard value, adjust as described below.

Remove the floor console cup tray or arm rest assembly, loosen the adjusting nut as far as the end of the cable rod to release the cable, and then adjust by the following procedure:

<Vehicles with drum brake>

Depress the brake pedal repeatedly until the stroke no longer changes.

<Vehicles with drum-in-disc brake>

- (1) Remove the adjustment hole plug, and then use a flat-tip screwdriver to turn the adjuster in the direction of the arrow (the direction which expands the shoe) so that the disc will not rotate. Return the adjuster five notches in the direction opposite to the direction of the arrow.

CAUTION

If the parking brake lever stroke is below the standard value and the braking is too firm, the rear brakes may drag.

- (2) Turn the adjusting nut to adjust the parking brake lever stroke to the standard value. After adjusting, check that there is no space between the adjusting nut and the parking brake lever.
- (3) After adjusting the parking brake lever stroke, jack up the rear of the vehicle. Release the parking brake and turn the rear wheels to check that the rear brakes are not dragging.

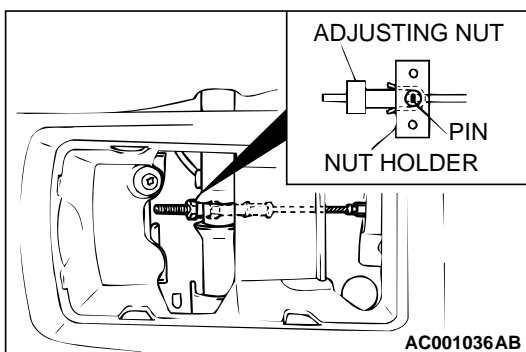
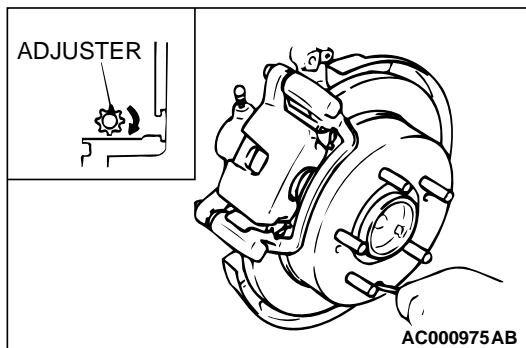
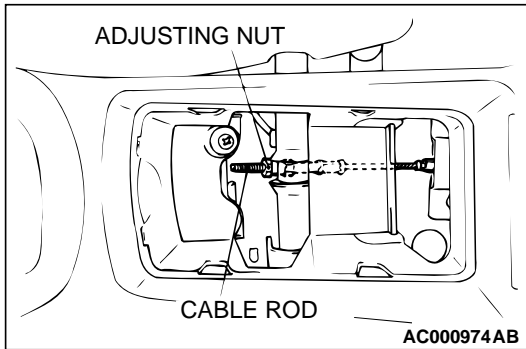

PARKING BRAKE SWITCH CHECK

M1361003300057

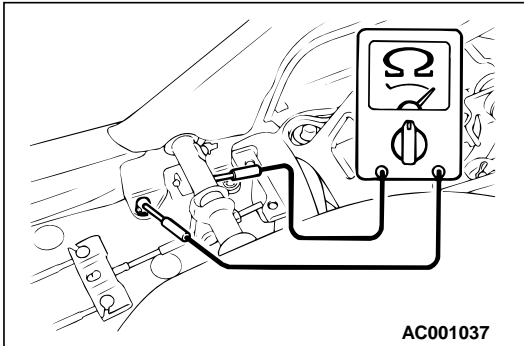

1. Remove the floor console. (Refer to GROUP 52A, Floor Console P.52A-11.)
2. Check for continuity between the parking brake switch terminal and the switch mounting bolt.

When parking brake lever is pulled	Less than 2 ohms
When parking brake lever is released	Open circuit

LINING RUNNING-IN

M1361001100057

⚠ CAUTION

Carry out running-in a place with good visibility, and pay careful attention to safety.

Carry out running-in by the following procedure when replacing the parking brake linings or the rear brake disc rotors, or when brake performance is insufficient.

1. Adjust the parking brake stroke to the specified value. (Refer to P.36-4.)
2. Hook a spring scale onto the center of the parking brake lever grip and pull it with a force of 98 – 147 N (22 – 33 pounds) in a direction perpendicular to the handle.
3. Drive the vehicle at a constant speed of 35 – 50 km/h (22 – 31 mph) for 100 meters (328 feet).
4. Release the parking brake and let the brakes cool for five to ten minutes.
5. Repeat the procedure in steps 2. to 4. four to five times.

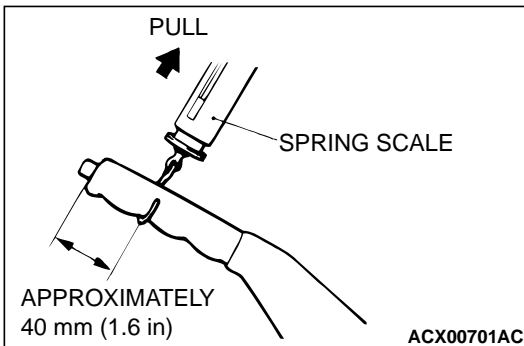

PARKING BRAKE LEVER

REMOVAL AND INSTALLATION

M1361001300051

Pre-removal Operation

Floor Console Removal (Refer to GROUP 52A, Floor Console P.52A-11.)

Post-installation Operation

- Parking Brake Lever Stroke Check and Adjustment (Refer to P.36-4.)
- Floor Console Installation (Refer to GROUP 52A, Floor Console P.52A-11.)

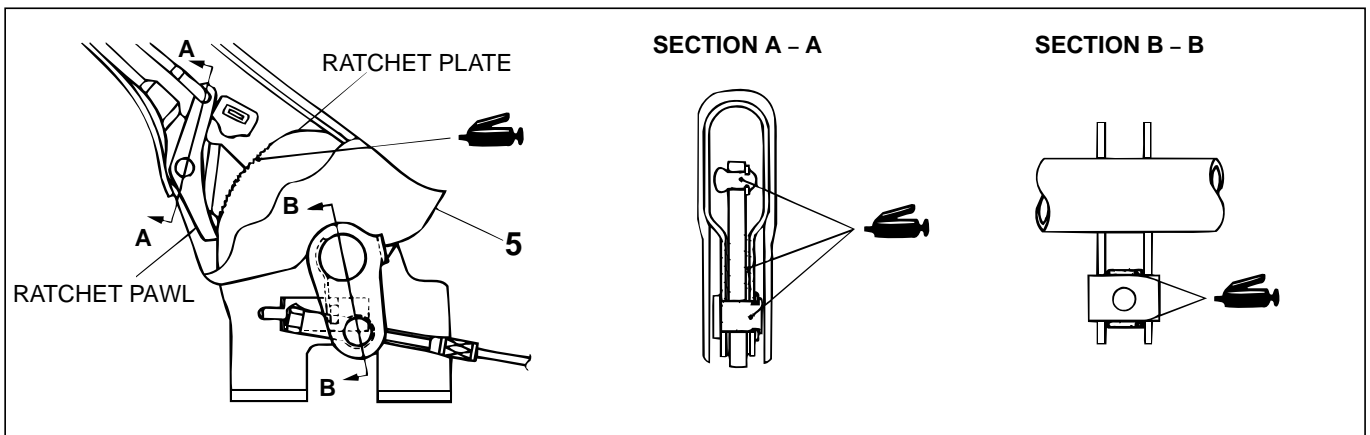
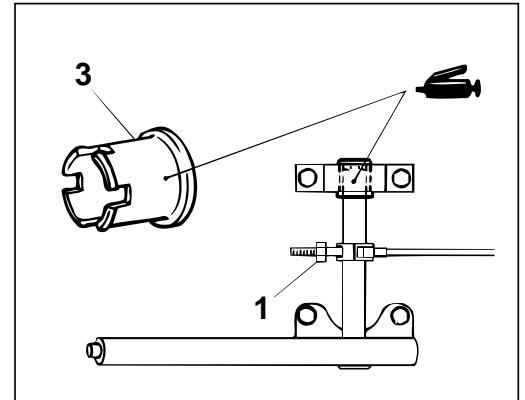
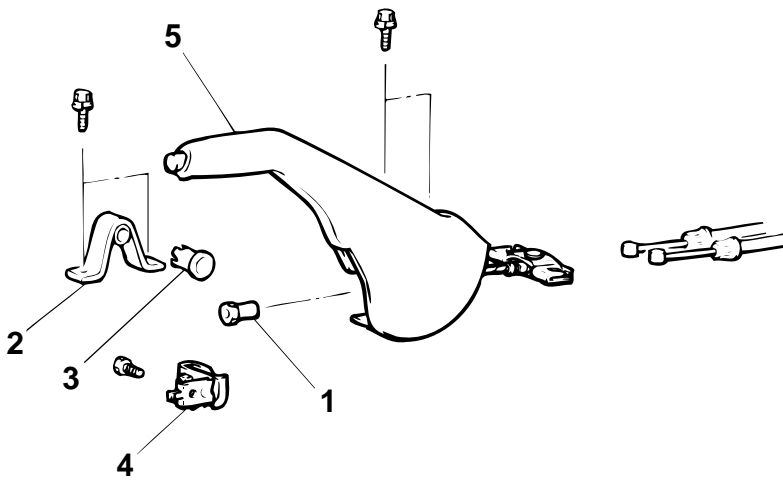

AC003118 AB

REMOVAL STEPS

1. ADJUSTING NUT
2. PARKING BRAKE STAY
3. BUSHING
4. PARKING BRAKE SWITCH
5. PARKING BRAKE LEVER

TSB Revision

PARKING BRAKE CABLE

REMOVAL AND INSTALLATION <DRUM BRAKE>

M1361001900075

<p>Pre-removal Operation Floor Console Removal (Refer to GROUP 52A, Floor Console P.52A-11.)</p>	<p>Post-installation Operation</p> <ul style="list-style-type: none"> • Parking Brake Lever Stroke Check and adjustment (Refer to P.36-4.) • Floor Console Installation (Refer to GROUP 52A, Floor Console P.52A-11.)
---	--

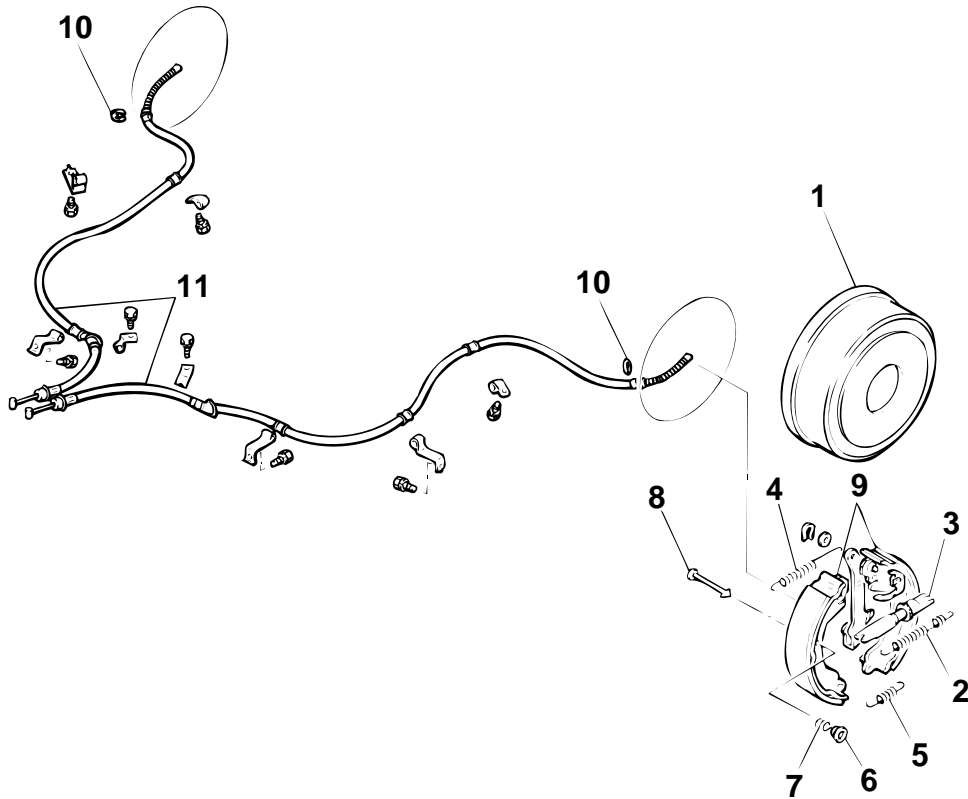

AC001131AB

REMOVAL STEPS

1. REAR BRAKE DRUM
2. SHOE-TO-LEVER SPRING
3. AUTO ADJUSTER ASSEMBLY
4. SHOE-TO-SHOE SPRING
5. RETAINER SPRING
6. SHOE HOLD-DOWN CUP

REMOVAL STEPS (Continued)

7. SHOE HOLD-DOWN SPRING
8. SHOE HOLD-DOWN PIN
9. SHOE AND LINING ASSEMBLY
10. SNAP RING
11. PARKING BRAKE CABLE

PARKING BRAKE CABLE

REMOVAL AND INSTALLATION <DRUM-IN-DISC BRAKE>

M1361001900086

<p>Pre-removal Operation Floor Console Removal (Refer to GROUP 52A, Floor Console P.52A-11.)</p>	<p>Post-installation Operation</p> <ul style="list-style-type: none"> • Parking Brake Lever Stroke Check and adjustment (Refer to P.36-4.) • Floor Console Installation (Refer to GROUP 52A, Floor Console P.52A-11.)
---	--

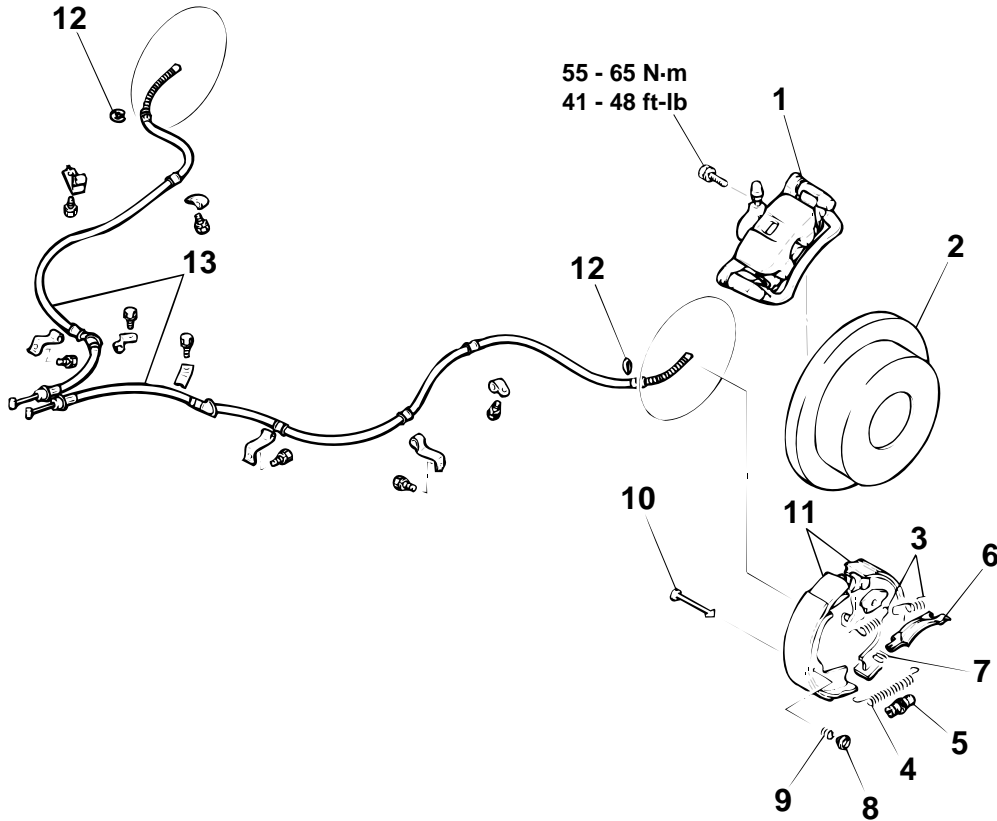

AC001201 AC

- <<A>>
- REMOVAL STEPS**
1. REAR BRAKE CALIPER ASSEMBLY
 2. REAR BRAKE DISC
 - >>B<< 3. SHOE-TO-ANCHOR SPRING
 4. ADJUSTING SCREW SPRING
 - >>A<< 5. ADJUSTER
 6. STRUT

- <>
- REMOVAL STEPS (Continued)**
7. STRUT RETURN SPRING
 8. SHOE HOLD-DOWN CUP
 9. SHOE HOLD-DOWN SPRING
 10. SHOE HOLD-DOWN PIN
 11. SHOE AND LINING ASSEMBLY
 12. CLIP
 13. PARKING BRAKE CABLE

REMOVAL SERVICE POINTS

<<A>> REAR BRAKE CALIPER ASSEMBLY REMOVAL

Remove the rear brake caliper assembly and support it with wire or something similar.

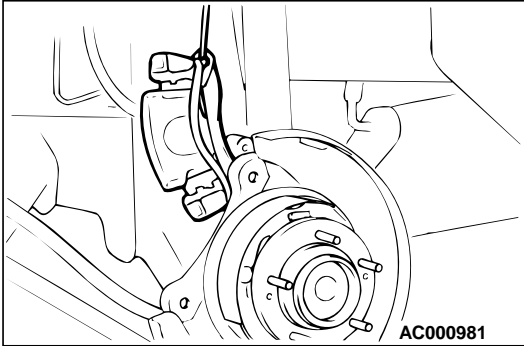

<> SHOE HOLD-DOWN CUP REMOVAL

Extend the shoe and lining assembly, and remove the shoe hold-down cup.

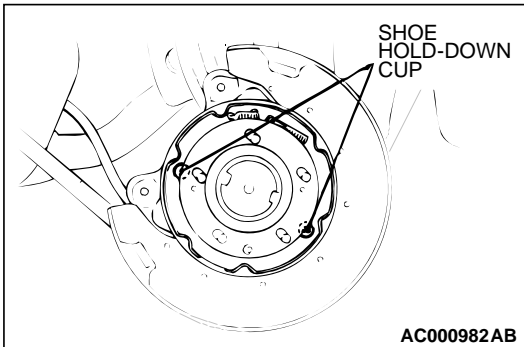

INSTALLATION SERVICE POINTS

>>A<< ADJUSTER INSTALLATION

Install the adjuster so that the shoe adjusting bolt of left hand wheel is attached towards the front of the vehicle, and the shoe adjusting bolt of right hand wheel is towards the rear of the vehicle.

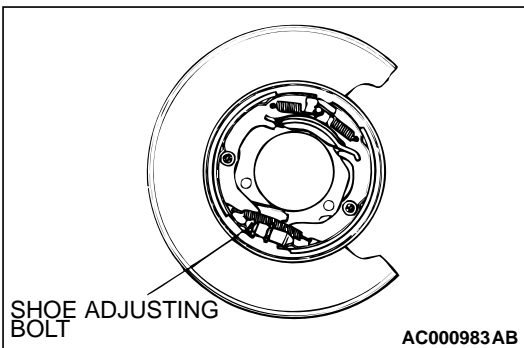

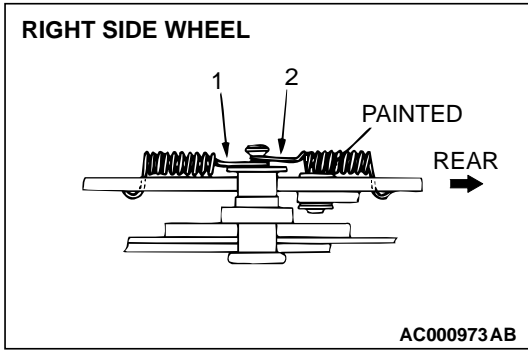

>>B<< SHOE-TO-ANCHOR SPRING INSTALLATION

CAUTION

The load on the respective shoe-to-anchor springs is different, so the rear side spring in the figure has been painted.

Install the shoe-to-anchor springs in the order shown in the illustration.

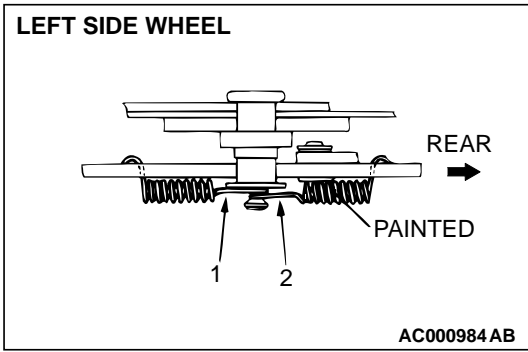

PARKING BRAKE LINING AND DRUM

REMOVAL AND INSTALLATION

M1361002500058

Post-installation Operation

Parking Brake Lever Stroke Check and Adjustment
(Refer to P.36-4.)

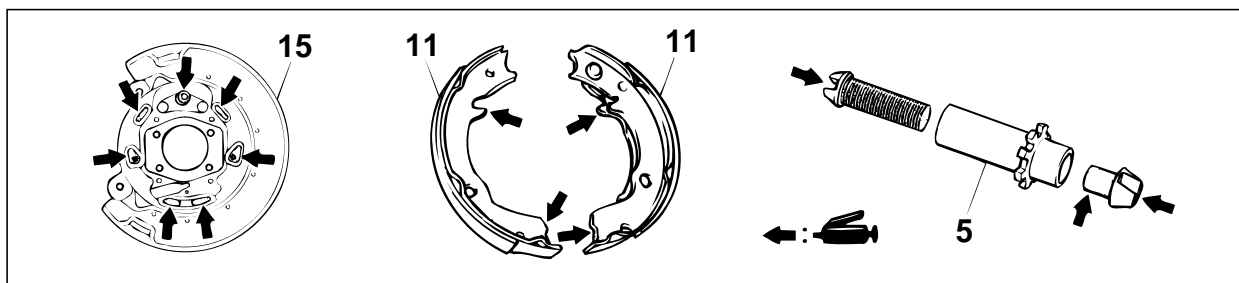
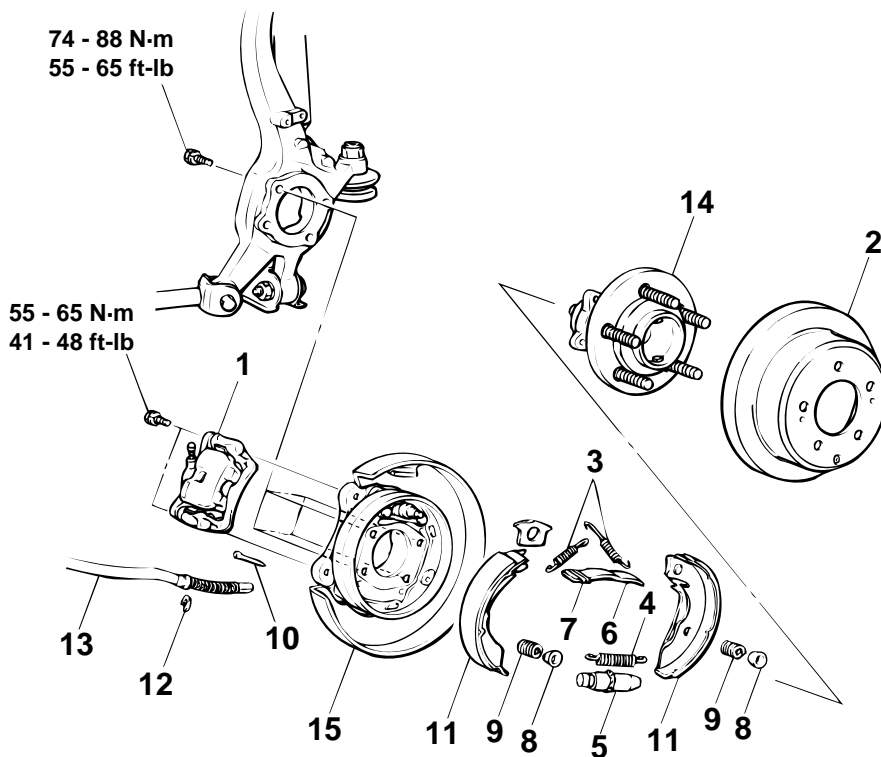

AC003119 AB

REMOVAL STEPS

1. REAR BRAKE CALIPER (REFER TO P.36-8.)
2. REAR BRAKE DISC
3. SHOE-TO-ANCHOR SPRING (REFER TO P.36-8.)
4. ADJUSTING SCREW SPRING
5. ADJUSTER (REFER TO P.36-8.)
6. STRUT
7. STRUT RETURN SPRING
8. SHOE HOLD-DOWN CUP (REFER TO P.36-8.)

REMOVAL STEPS (Continued)

9. SHOE HOLD-DOWN SPRING
10. SHOE HOLD-DOWN PIN
11. SHOE AND LINING ASSEMBLY
12. CLIP
13. PARKING BRAKE CABLE
14. REAR HUB ASSEMBLY (REFER TO GROUP 27, REAR AXLE HUB P.27-6.)
15. BACKING PLATE

TSB Revision

BRAKE LINING AND BRAKE DRUM CHECK

M1361002600055

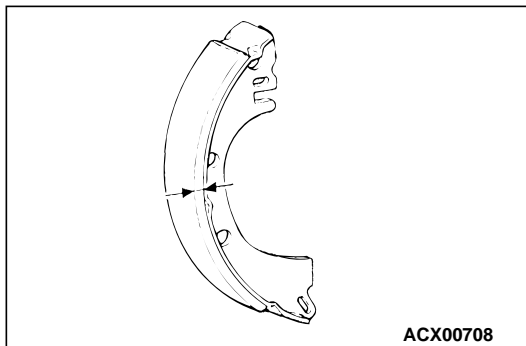

ACX00708

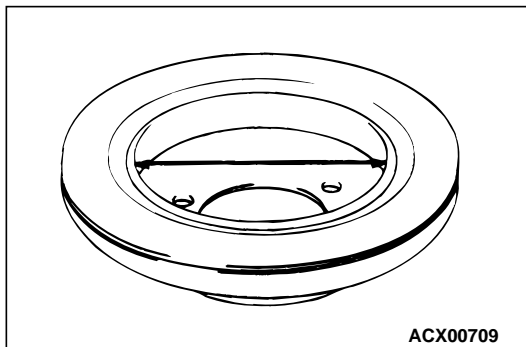

ACX00709

1. Measure the thickness of the brake lining at several places.
Standard value: 2.8 mm (0.11 inch)
Minimum limit: 1.0 mm (0.04 inch)
2. If the thickness of the brake lining is below the limit, replace the shoe and lining assemblies on both sides of the vehicle. Never replace only one side.
3. Measure the inside diameter of the brake disc in two places or more.
Standard value: 168.0 mm (6.61 inch)
Limit: 169.0 mm (6.65 inch)
4. If the inside diameter exceeds the limit, or if it is excessively worn on one side, replace the brake disc.

SPECIFICATIONS

FASTENER TIGHTENING SPECIFICATIONS

M1361003500051

ITEMS		SPECIFICATIONS
Brake caliper assembly <Drum-in-disc brake>	Break caliper assembly	55 – 65 N·m (41 – 48 ft-lb)
Parking brake lining and drum	Break caliper assembly	55 – 65 N·m (41 – 48 ft-lb)
	Knuckle to backing plate bolt	74 – 88 N·m (55 – 65 ft-lb)

SERVICE SPECIFICATIONS

M1361000300058

ITEMS		STANDARD VALUE	LIMIT
Parking brake lever stroke	Vehicles with drum brake	5 – 7 notches	–
	Vehicles with drum-in-disc brake	3 – 5 notches	–
Rear brake lining thickness mm (in)		2.8 (0.11)	Minimum 1.0 (0.04)
Brake drum inside diameter mm (in)		168.0 (6.61)	169.0 (6.65)

LUBRICANTS

M1361000400055

ITEMS	SPECIFIED LUBRIVCANT
Backing plate	Brake grease SAE J310, NLGI No.1
Adjuster	
Shoe and lining assembly	