

## GROUP 54B

# SIMPLIFIED WIRING SYSTEM (SWS)

## CONTENTS

<b>GENERAL DESCRIPTION</b> .....	<b>54B-2</b>	DIAGNOSTIC TROUBLE CODE CHART ..	54B-8
COMMUNICATION METHOD .....	54B-2	SYMPTOM CHART .....	54B-9
OPERATION .....	54B-2	DIAGNOSTIC TROUBLE CODE PROCEDURES	
		.....	54B-12
<b>SWS DIAGNOSIS</b> .....	<b>54B-5</b>	SYMPTOM PROCEDURES .....	54B-31
INTRODUCTION TO SWS DIAGNOSIS ..	54B-5	CHECK THE CIRCUIT (POWER SUPPLY LINE)	
SWS DIAGNOSTIC TROUBLESHOOTING		FROM BATTERY .....	54B-266
STRATEGY .....	54B-5		
SWS TROUBLE CODE DIAGNOSIS .....	54B-5	<b>SPECIAL TOOLS</b> .....	<b>54B-268</b>

## GENERAL DESCRIPTION

### COMMUNICATION METHOD

M1549013000075

As shown below, signal wires used exclusively for transmitting multiplex signal data connect the ETACS-ECU, front-ECU, column switch (incorporating the column-ECU) and these components communicate with each other.

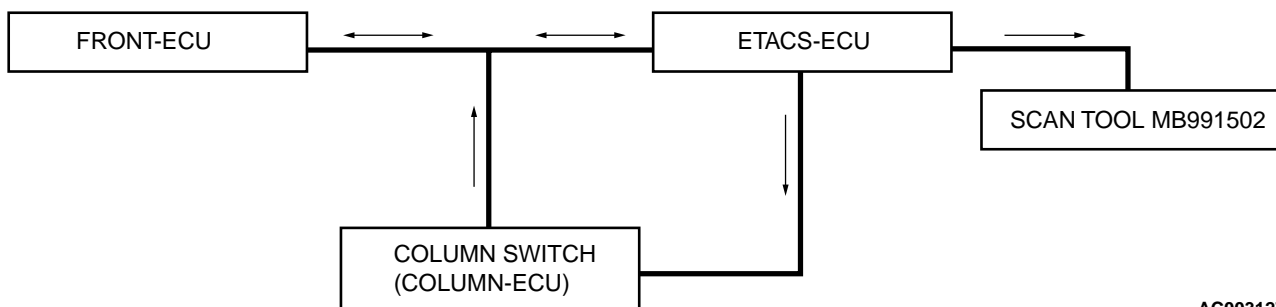

AC003127AB

### OPERATION

M1549013100061

#### TONE ALARM

##### Ignition Key Reminder Tone Alarm Function

When the driver's door is opened (driver's door switch ON) without removing the ignition key [ignition switch to "LOCK" (OFF) or "ACC" position], the tone alarm will sound intermittently to remind the driver that the ignition key has not been removed.

##### Light Reminder Tone Alarm Function

When the driver's door is opened (driver's door switch ON) with the lighting switch (taillight switch or headlight switch) in the ON position and the ignition switch in the "LOCK" (OFF) or "ACC" position, the tone alarm will sound continuously to remind the driver that the lights (taillights or headlights) are ON. This function does not work if the taillights or headlights are switched off through the headlight automatic shutdown function. In addition, the ignition key reminder tone alarm function has a priority over this function.

##### Seat Belt Tone Alarm Function

When the ignition switch is turned to "ON" position without fastening the seat belts (seat belt switch OFF), the tone alarm will sound for approximately 6 seconds to warn the driver to fasten the seat belts. When the seat belts are fastened, the tone alarm will stop sounding.

#### CENTRAL DOOR LOCKING SYSTEM

##### Central Door Locking System Operation

- When the driver's inside lock knob is locked or unlocked, the lock relay inside the ETACS-ECU turns on to lock or unlock all doors.
- With all the doors locked, turning the key inserted in the driver's door unlocks the door. Turning it again makes the door unlock relay close to send a signal for unlocking all doors.
- When the door lock switch (built into the power window switch) is operated, the lock or unlock relay inside the ETACS-ECU is turned on to lock or unlock all doors.

##### Forgotten Key Prevention Function

- If the driver's door is open position (door switch turned ON) when the key is inserted in the ignition switch (key reminder switch turned OFF), the ETACS-ECU activates the door unlock relay for 0.5 second to prevent the door from being locked.
- If the driver's and front passenger's doors are locked when the front passenger's door is in its open position (door switch turned ON) and the key is inserted in the ignition switch (key reminder switch turned OFF), the ETACS-ECU prevents the doors from being locked by activating the door unlock relay for 0.5 second.

## POWER WINDOW RELAY CONTROL

### Power Window Relay Operation

If the ignition switch is turned to "ON" position, the power window relay is energized to activate the power windows.

### Power Window Timer Function

When the ignition switch is turned from "ON" position to "LOCK" (OFF) or "ACC" position, the power windows will be ready to work for 30 seconds, the power windows will be immobilized at that point.

## KEYLESS ENTRY SYSTEM

### Keyless Entry Answerback Function

If the transmitter "LOCK" or "UNLOCK" switch is pressed while the ignition key is removed, the doors can be locked or unlocked. If the doors are closed, the hazard warning lights, the dome light and the horn will operate due to answerback function.

Because of the answerback function, the hazard warning lights flash twice, and the horn sounds once, the dome light flashes twice when the doors are locked. Meanwhile, when the doors are unlocked, the hazard warning lights flash and the dome light illuminates for 30 seconds. The hazard and the horn answerback functions can be cancelled by using the transmitter.

## WINDSHIELD WIPERS AND WASHERS

### Windshield Low-speed (and High-speed) Wiper Operation

- If the windshield low-speed wiper switch is turned to ON position with the ignition switch at the "ACC" or "ON" position, the column switch sends a low-speed wiper ON and high-speed wiper OFF signals to the front-ECU. This turns the wiper signal on and the wiper speed switching relay off (low-speed), causing the wipers to operate at low-speed.
- If the windshield high-speed wiper switch is turned to ON position, the column switch sends a low-speed wiper OFF and high-speed wiper ON signals to the front-ECU. This turns both the wiper signal and the wiper speed switching relay on (high-speed), causing the wipers to operate at high-speed.

### Windshield Intermittent Wiper Operation

The ETACS-ECU calculates the wiper operation interval according to the voltage signal sent from the column switch. Then the ETACS-ECU sends a signal to the front-ECU. The front-ECU determines the wiper operation interval and turns on the wiper relay signal relay. This causes the wiper auto stop relay to

turn on. Then the wiper auto stop relay to turn on. Then the wiper auto stop relay will turn off after the wipers reach the park position. This causes the wiper signal relay and then the wipers to turn off. If the wiper signal relay remains off for the wiper operation interval, the relay turns on again, causing the wipers to operate in intermittent mode.

### Windshield Mist Wiper Operation

- If the windshield mist wiper switch is turned to ON position with the ignition switch at "ACC" or "ON" position, the mist wiper high-speed operation signal is sent to the front-ECU. This signal turns on the wiper speed switching relay, causing the wipers to work at high-speed while the mist switch is on.
- While the windshield mist wiper switch remains turned on when the intermittent mode is still working, the wipers work as the mist wiper. However, the wipers return to the intermittent mode again when the wiper auto stop signal turn on after the windshield mist wiper switch is turned off.

### Windshield Washer Operation

- If the windshield washer switch is turned to ON position with the ignition switch at "ACC" or "ON" position, the windshield washer ON signal is sent to the front-ECU, causing the windshield wiper signal to turn on after 0.6 seconds. After the windshield washer switch signal turns off, the windshield wiper signal turns off in three seconds.
- If the windshield washer switch is turned on while the windshield wiper is at intermittent mode, the windshield washer works for that period when the windshield washer switch remains on. Then the wipers return to the intermittent mode.

## SEAT BELT WARNING LIGHT

If the driver turns the ignition switch to the "ON" position without wearing the seat belt, the seat belt warning light illuminates to alert the driver to wear the seat belt.

## IGNITION KEY HOLE ILLUMINATION LIGHT

When the ignition switch is turned to "LOCK" (OFF) or "ACC" position with the driver's door opened, the ignition key hole illumination light is illuminated. If the door is closed in that state, the light goes out after 30 seconds or it illuminates for 30 seconds after the ignition key is removed. In either case the light goes out when the ignition switch is turned to the "ON" position.

## HEADLIGHT

### Headlight Automatic Shutdown Function

If ignition switch is turned to "LOCK" (OFF) or "ACC" position or the taillights are on, the headlights will be switched off in 3 minutes. If the driver's door is opened within that 3 minute period, the headlights will be switched off automatically. This prevents the battery from discharging. In addition, if the headlights or the taillights are turned on when the ignition switch is at "LOCK" (OFF) or "ACC" position or the ignition key is removed, the headlights will not be switched off.

### Headlight Dimmer Switch Automatic Resetting Function

This function allows the dimmer switch to be reset to the low-beam position whenever the headlight switch is turned to ON position.

## FLASHER TIMER

### Turn-signal Light

When the ignition switch is turned to "ON" position and turn-signal light switch is placed in the ON position for right or left turn-signaling, the system generates turn-signal light drive signals (flashing signals). The system also notifies of a blown turn-signal light bulb by shortening the flashing intervals of the corresponding indicator light.

### Hazard Warning Light

The system detects a change from OFF to ON of the hazard warning input signal and activates the hazard warning lights if they are not in operation or deactivates the lights if they are operating (reversal of state between activation and deactivation).

## FOG LIGHT

The fog light switch becomes active only when the headlights are at the low-beam mode. Therefore, if the headlights are turned off, the fog lights will also be switched off. Whenever the headlights are turned on at the next time, the fog light will always be off regardless of the switch position.

## DOME LIGHT

With the dome light switch in the "door controlled operation" position, the ETACS-ECU controls the dome light operation as follows:

- When a door is opened from outside or inside [with the ignition switch turned to "LOCK" (OFF)]: When a door is opened, the ETACS-ECU causes the dome light to be illuminated at the 100% intensity. When the door is closed, it dims out the dome light to 65% intensity and approximately 30 seconds later, turns out the light completely. During this period (timer controlled period), the dome light goes out if the ignition switch is turned "ON" or the doors are locked.
- When a door is opened or closed with the ignition switch in the "ON" position: The dome light illuminates at 100% intensity when a door is opened and turned out when it is closed.
- When no door is opened and the ignition key is removed: When the ignition key is removed with all the doors closed, the dome light is illuminated at 100% intensity and turned out approximately 30 seconds later. During that time (timer-controlled period), the dome light goes out if the ignition key is inserted and turned to "ON" or the door locking system is activated.
- Dome light's answerback operation in response to door lock control by keyless entry system: To allow the driver to ascertain the result of the door locking/unlocking control action by the use of the keyless entry system, the ETACS-ECU causes the dome light to blink twice when the doors are locked through the system and to illuminate for approximately 15 seconds when the doors are locked. The dome light's answerback operation in response to a keyless entry system control action is accompanied by operation of the hazard warning lights.

## THEFT-ALARM SYSTEM

### Theft-alarm System Operation

When the theft-alarm system has been armed if a door, trunk lid or hood is opened, the horn will sound and headlights flash (high-beam) intermittently for a period of 180 seconds.

### Panic Alarm Function

With the theft-alarm function armed, pressing the panic button on the keyless entry system transmitter causes the theft-alarm horn to sound for about 180 seconds in an attempt to prevent theft. The alarm is turned off by pressing any switch on the transmitter.

## SWS DIAGNOSIS

### INTRODUCTION TO SWS DIAGNOSIS

M1549001900071

The SWS reduces the number of wires by sending multiple signals along a single wire. This reduces vehicle weight and simplifies construction by reducing wiring harness complexity weight. The ETACS-ECU, front-ECU and column switch (incorporated in column-ECU) have multiplex signal circuits that enable them to transmit and/or receive multiple signals and communicate with other control unit.

### SWS DIAGNOSTIC TROUBLESHOOTING STRATEGY

M1549000500081

Use these steps to plan your diagnostic strategy. If you follow them carefully, you will be sure that you have exhausted most of the possible ways to find a SWS fault.

1. Gather information about the problem from the customer.
2. Verify that the condition described by the customer exists.
3. Check the vehicle for any SWS DTC.
4. If you cannot verify the condition and there are no SWS DTCs, the malfunction is intermittent. Refer to GROUP 00, How to Use Troubleshooting/ Inspection Service Points – How to Cope with Intermittent Malfunctions P.00E-5.
5. If you can verify the condition but there are no SWS DTCs, or the system cannot communicate with the scan tool, refer to Symptom Chart.
6. If there is a SWS DTC, perform the diagnostic procedures for the DTC. Refer to Diagnostic Trouble Chart.

### SWS TROUBLE CODE DIAGNOSIS

M1549000600077

#### Retrieving SWS Diagnostic Trouble Codes

##### Required Special Tool:

- MB991502: Scan Tool (MUT-II)

##### **CAUTION**

**To prevent damage to scan tool MB991502, always turn the ignition switch to "LOCK" (OFF) position before connecting or disconnecting scan tool MB991502.**

1. Connect scan tool MB991502 to the data link connector.
2. Use scan tool MB991502 to check for SWS diagnostic trouble codes.
3. Turn the ignition switch to "LOCK" (OFF) position.
4. Disconnect scan tool MB991502.

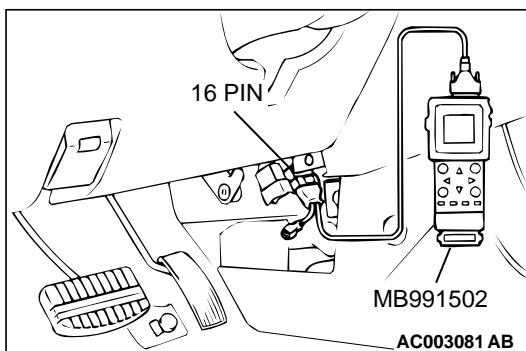

#### Input Signal Check Function

This mode checks the switch input signals to each ECU incorporated in the SWS. If a defect is found at this check, carry out the troubleshooting by referring to Symptom Chart.

<When using scan tool MB991502>

Required Special Tool:

- MB991502: Scan Tool (MUT-II)

**CAUTION**

To prevent damage to scan tool MB991502, always turn the ignition switch to "LOCK" (OFF) position before connecting or disconnecting scan tool MB991502.

1. Connect scan tool MB991502 to the data link connector.
2. If input signal is sent to the data link connector, tone alarm of scan tool MB991502 will sound.
3. Turn the ignition switch to "LOCK" (OFF) position.
4. Disconnect scan tool MB991502.

<When using a voltmeter>

Required Special Tool

- MB991529: Diagnostic Trouble Code Check Harness

1. Connect special tool MB991529 to connect a voltmeter between grounded terminal 4 or 5 and ETACS-ECU terminal 9 of the 16 pin data link connector.
2. If input signal is sent to the data link connector, the voltmeter needle will fluctuate once.
3. Disconnect special tool MB991529.

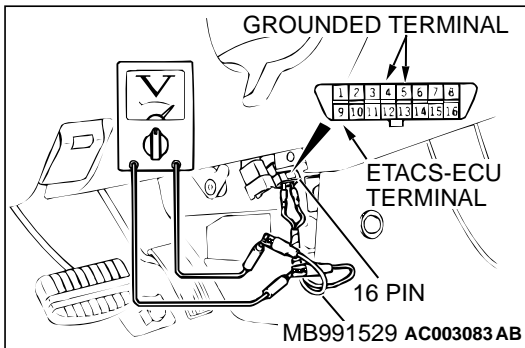
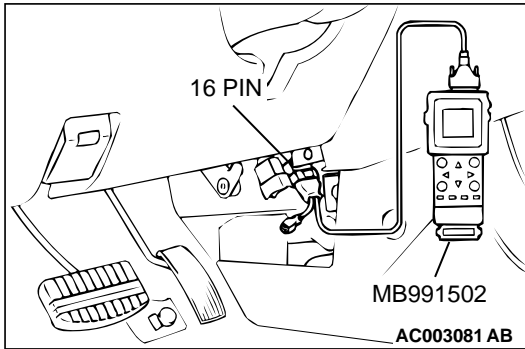

Requirements for which switches send input signals

SWITCHES WHICH SEND INPUT SIGNAL	REQUIREMENTS FOR SWITCHES SEND INPUT SIGNAL
Ignition switch (ACC)	Turn from "LOCK" (OFF) to "ACC"
Ignition switch (IG1)	Turn from "ACC" to "ON"
Key reminder switch	Remove the ignition key from ignition key cylinder (from inserted position)
Hazard warning light switch	Turn from OFF to ON
Fog light switch	
Driver's seat belt switch	Remove the seat belt tongue from the seat belt buckle with the ignition key "ON" position
Driver's or passenger's door switch	Open the door
Door switches	Open any door when all doors are closed
Driver's or front passenger's door lock key cylinder switch	Turn the key to the lock or unlock position
Driver's or front passenger's door lock actuator switch	Move the door lock knob from lock position to unlock position or vice versa
Rear door lock actuator switch <Vehicles with theft-alarm system>	

<b>SWITCHES WHICH SEND INPUT SIGNAL</b>		<b>REQUIREMENTS FOR SWITCHES SEND INPUT SIGNAL</b>
Door lock switch (incorporated in power window main switch and power window sub switch)		Press "LOCK" or "UNLOCK" side
Hood switch <Vehicles with theft-alarm system>		Open the hood
Trunk lid latch switch <Vehicles with theft-alarm system>		Open the trunk lid
Trunk lid lock key cylinder switch <Vehicles with theft-alarm system>		Turn the key the unlock position
Column switch	Taillight switch	Turn the lighting switch from "OFF" to "TAILLIGHT" position
	Headlight switch	Turn the lighting switch from "TAILLIGHT" to "HEADLIGHT" position
	Passing light switch	Turn the dimmer/passing switch from "OFF" to "PASSING" position
	Dimmer switch	Turn the dimmer/passing switch from "PASSING" to "DIMMER" position
	Turn-signal light switch	Turn from OFF to ON
	Windshield mist wiper switch	
	Windshield intermittent wiper switch	
	Windshield low-speed wiper switch	
	Windshield high-speed wiper switch	
		Windshield intermittent wiper interval adjusting knob
	Windshield washer switch	Turn from OFF to ON
Transmitter <Vehicles with keyless entry system>	"LOCK" switch	
	"UNLOCK" switch	
	"PANIC" switch <Vehicles with theft-alarm system>	

**DIAGNOSTIC TROUBLE CODE CHART**

M1549000700074

Refer to the relevant page according to the diagnostic troubles codes.

<b>DIAGNOSTIC TROUBLE CODE NO.</b>	<b>DESCRIPTION</b>	<b>REFERENCE PAGE</b>
11	ETACS-ECU fault	<a href="#">P.54B-12</a>

TSB Revision

DIAGNOSTIC TROUBLE CODE NO.	DESCRIPTION	REFERENCE PAGE
12	Column switch fault or improper connection to the ETACS-ECU	P.54B-13
13	Front-ECU fault	P.54B-20
21	Short circuit in communication line	P.54B-26

## SYMPTOM CHART

M1549000800071

SYSTEMS	SYMPTOMS	INSPECTION PROCEDURE	REFERENCE PAGE
	Scan tool MB991502 communication is not possible.	A-1	P.54B-31
Tone alarm	Ignition key reminder tone alarm function does not work normally.	B-1	P.54B-34
	Light reminder tone alarm function does not work normally.	B-2	P.54B-36
	Seat belt tone alarm function does not work normally.	B-5	P.54B-37
Central door locking system	Central door locking system does not operate.	C-1	P.54B-40
	Some doors do not lock or unlock.	C-2	P.54B-46
	All the doors do not lock or unlock with just the door lock switch operation.	C-3	P.54B-57
	All the doors do not lock or unlock with just the door lock key cylinder key operation.	C-4	P.54B-58
	All the doors do not lock with just the driver's inside lock knob lock operation.	C-5	P.54B-59
	Forgotten key prevention function does not work.	C-6	P.54B-60
Power window relay	Power windows do not work at all.	D-1	P.54B-62
	Power window timer function does not work normally.	D-2	P.54B-67
Keyless entry system	Keyless entry system does not operate.	E-1	P.54B-69
	The dome light, the hazard warning lights and the horn do not operate through the answerback function.	E-2	P.54B-71
	The encrypted code cannot be registered.	E-4	P.54B-80
Windshield wiper and washer	Windshield wiper does not operate.	F-1	P.54B-82
	Any of the windshield wiper switch positions is defective.	F-2	P.54B-87
	Windshield wiper does not stop at the predetermined park position.	F-3	P.54B-90
	Windshield intermittent wiper interval cannot be adjusted.	F-4	P.54B-95
	Windshield washer does not work.	F-5	P.54B-98

TSB Revision



<b>SYSTEMS</b>	<b>SYMPTOMS</b>	<b>INSPECTION PROCEDURE</b>	<b>REFERENCE PAGE</b>
Seat belt warning light	Seat belt warning light does not work normally.	G-1	<a href="#">P.54B-104</a>
Ignition key hole illumination light	Ignition key hole illumination light does not work normally.	H-1	<a href="#">P.54B-110</a>
Headlight, taillight	Taillights do not illuminate.	I-1	<a href="#">P.54B-118</a>
	Headlights (low-beam) do not illuminate.	I-2	<a href="#">P.54B-122</a>
	Headlights (high-beam) do not illuminate.	I-3	<a href="#">P.54B-128</a>
	Headlights do not illuminate when the passing switch is operated.	I-4	<a href="#">P.54B-133</a>
	The high-beam indicator light does not illuminate.	J-5	<a href="#">P.54B-135</a>
	The headlight automatic shutdown function does not work normally.	I-6	<a href="#">P.54B-141</a>
	Headlight dimmer switch automatic resetting function does not work normally.	I-7	<a href="#">P.54B-143</a>
Flasher timer	Turn-signal lights do not flash when the turn-signal light switch is turned on.	J-1	<a href="#">P.54B-144</a>
	Hazard warning lights do not flash when the hazard warning light switch is turned on.	J-2	<a href="#">P.54B-149</a>
Fog light	Fog lights do not illuminate when the fog light switch is turned on.	K-1	<a href="#">P.54B-151</a>
	Fog lights do not go out when the headlights (low-beam) are turned off while the fog lights are on.	K-2	<a href="#">P.54B-157</a>
Dome light	The dome light does not illuminate.	L-1	<a href="#">P.54B-158</a>
	The dome light dimming function does not work normally.	L-2	<a href="#">P.54B-161</a>
Theft-alarm system	Theft-alarm system is not armed ("SECURITY" indicator light does not illuminate)	M-1	<a href="#">P.54B-166</a>
	The horn does not sound when the theft-alarm system is triggered.	M-2	<a href="#">P.54B-173</a>
	The headlights (high-beam) do not flash when the theft-alarm system is triggered.	M-3	<a href="#">P.54B-181</a>
	The panic alarm function does not work.	M-4	<a href="#">P.54B-181</a>

**DEFECTS FOUND BY INPUT SIGNAL CHECK**

If the input signal check finds a defect, follow the table below to check.

SYMPTOMS		INSPECTION PROCEDURE	REFERENCE PAGE
The ignition switch (ACC) signal is not sent to the ETACS-ECU.		N-1	<a href="#">P.54B-183</a>
The ignition switch (IG1) signal is not sent to the ETACS-ECU.		N-2	<a href="#">P.54B-185</a>
The key reminder switch signal is not sent to the ETACS-ECU.		N-3	<a href="#">P.54B-187</a>
The hazard warning light switch signal is not sent to the ETACS-ECU.		N-4	<a href="#">P.54B-190</a>
The fog light switch signal is not sent to the ETACS-ECU.		N-5	<a href="#">P.54B-194</a>
The driver's seat belt switch signal is not sent to the ETACS-ECU.		N-6	<a href="#">P.54B-197</a>
The driver's or front passenger's door switch signal is not sent to the ETACS-ECU.		N-7	<a href="#">P.54B-202</a>
The door switches signals is not sent to the ETACS-ECU.			
The driver's or front passenger's door lock key cylinder switch signal is not sent to the ETACS-ECU.		N-8	<a href="#">P.54B-212</a>
The driver's or front passenger's door lock actuator switch signal is not sent to the ETACS-ECU.		N-9	<a href="#">P.54B-220</a>
The rear door lock actuator switch signal is not sent to the ETACS-ECU.			
The door lock switch (incorporated in power window main switch and power window sub switch) signal is not sent to the ETACS-ECU.		N-10	<a href="#">P.54B-237</a>
The hood switch signal is not sent to ETACS-ECU.		N-11	<a href="#">P.54B-245</a>
The trunk lid latch switch signal is not sent to ETACS-ECU.		N-12	<a href="#">P.54B-250</a>
The trunk lid lock key cylinder switch signal is not sent to ETACS-ECU.		N-13	<a href="#">P.54B-254</a>
Column switch	The taillight switch signal is not sent to the ETACS-ECU.	N-14	<a href="#">P.54B-258</a>
	The headlight switch signal is not sent to the ETACS-ECU.		
	The passing light switch signal is not sent to the ETACS-ECU.		
	The dimmer switch signal is not sent to the ETACS-ECU.		
	The turn-signal light switch signal is not sent to the ETACS-ECU.		
	The windshield mist wiper switch signal is not sent to the ETACS-ECU.	N-15	<a href="#">P.54B-260</a>
	The windshield intermittent wiper switch signal is not sent to the ETACS-ECU.		
	The windshield low-speed wiper switch signal is not sent to the ETACS-ECU.		
	The windshield high-speed wiper switch signal is not sent to the ETACS-ECU.		
	The windshield intermittent wiper intervals adjusting knob signal is not sent to the ETACS-ECU.	N-16	<a href="#">P.54B-262</a>
	The windshield washer signal is not sent to the ETACS-ECU.	N-15	<a href="#">P.54B-260</a>

SYMPTOMS		INSPECTION PROCEDURE	REFERENCE PAGE
Transmitter	The "LOCK" switch signal is not sent to the ETACS-ECU.	N-17	<a href="#">P.54B-265</a>
	The "UNLOCK" switch signal is not sent to the ETACS-ECU.		
	The "PANIC" switch signal is not sent to the ETACS-ECU.		

## DIAGNOSTIC TROUBLE CODE PROCEDURES

---

### DTC 11: ETACS-ECU fault

---

#### DTC SET CONDITION

DTC 11 is displayed when the ETACS-ECU detects an error in its own data. This fault is limited to the ETACS-ECU.

#### TROUBLESHOOTING HINT

Malfunction of the ETACS-ECU

#### DIAGNOSIS

##### Required Special Tool:

- MB991502: Scan Tool (MUT-II)

Replace the ETACS-ECU.

Confirm that DTC 11 is not displayed.

DTC 12: Column switch fault or improper connection to the ETACS-ECU

Column Switch Power Supply and SWS Communication Circuit

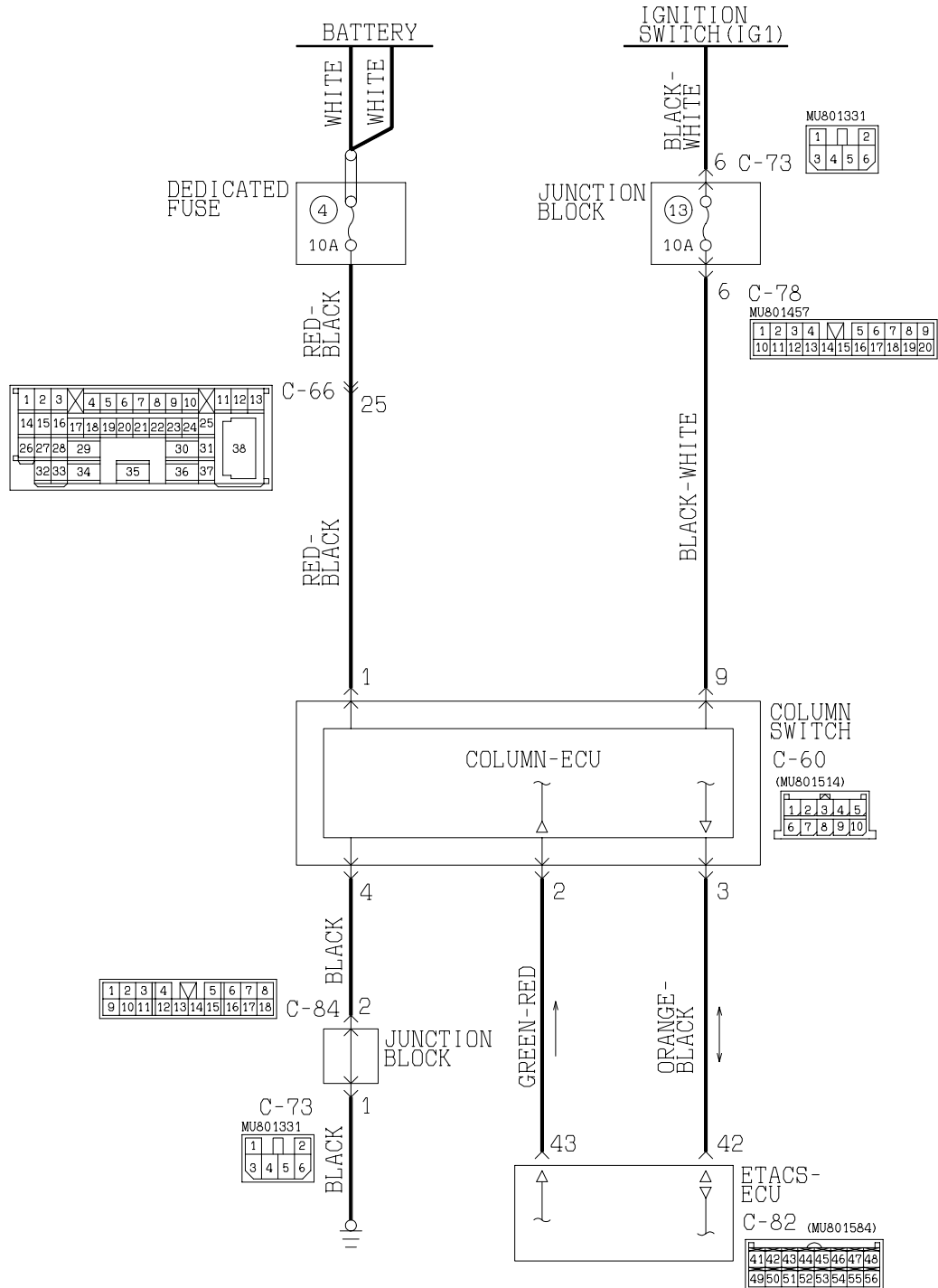

TSB Revision

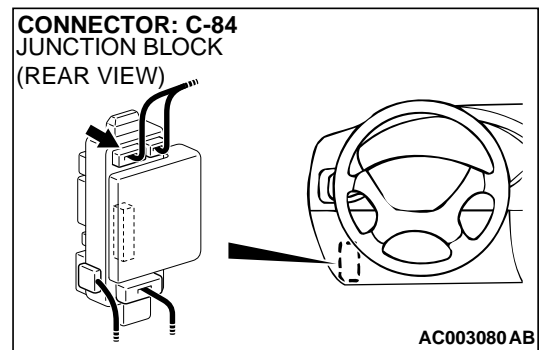
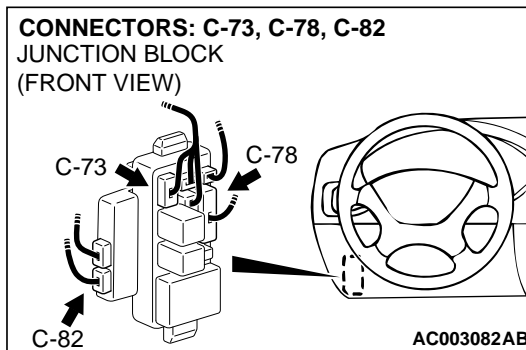
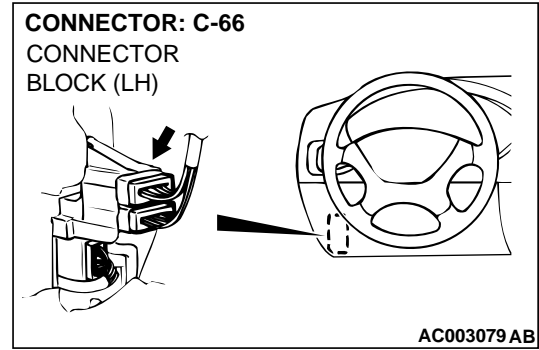
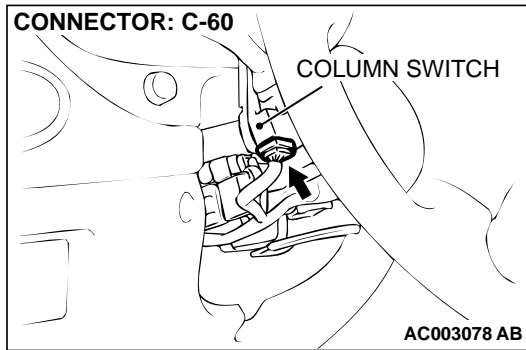

**CIRCUIT OPERATION**

- The column switch (incorporated in ECU) is energized by the battery and the ignition switch (IG1). If one of the harness wires has an open circuit, power will be supplied by the other active harness wire.
- If the column switch (incorporated in ECU) receives a request signal from the ETACS-ECU, the column switch will inform the SWS communication line of various switch conditions.

**DTC SET CONDITION**

DTC 12 is displayed when the column switch (incorporated in ECU) sends an abnormal signal to the ETACS-ECU.

**TROUBLESHOOTING HINTS**

- Malfunction of the column switch
- Malfunction of the ETACS-ECU
- Damaged harness wires or connectors

**DIAGNOSIS**

**Required Special Tools:**

- MB991223: Harness Set
- MB991502: Scan Tool (MUT-II)

**STEP 1. Check the ignition switch position.**

**Q: Does DTC 11 set with the ignition switch at "ON" position?**

**YES :** Go to Step 5.

**NO :** Go to Step 2.

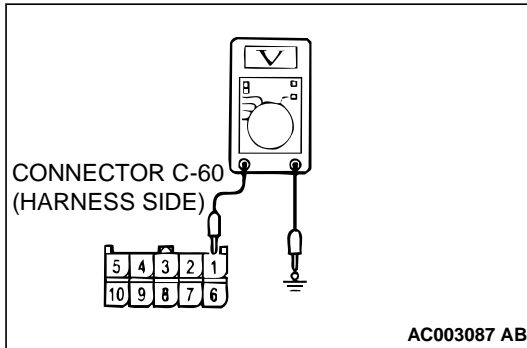

**STEP 2. Check the column switch power supply circuit (battery circuit) at the column switch connector C-60 by backprobing.**

- (1) Do not disconnect the column switch connector C-60.
- (2) Measure the voltage between terminal 1 and ground by backprobing.

**Q: Is the voltage approximately 12 volts (battery positive voltage)?**

**YES :** Go to Step 8.

**NO :** Go to Step 3.

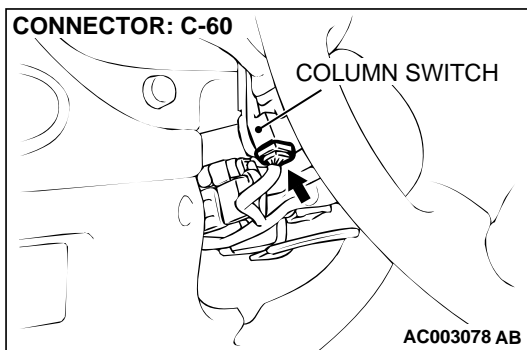

**STEP 3. Check the column switch connector C-60 for damage.**

**Q: Is column switch connector C-60 in good condition?**

**YES :** Go to Step 4.

**NO :** Repair or replace it. Refer to GROUP 00E, Harness Connector Inspection [P.00E-2](#) . Confirm the DTC 12 is not displayed.

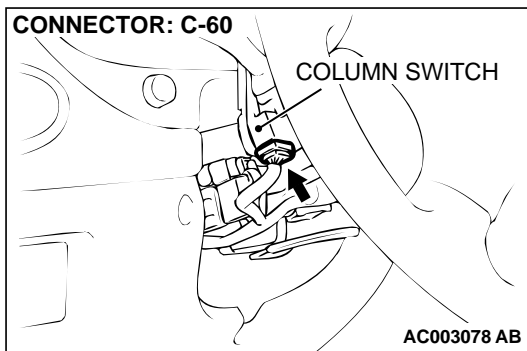

**STEP 4. Check the harness wires between column switch connector C-60 and battery.**

*NOTE: After checking joint connectors C-66, check the wires. If intermediate connector C-66 is damaged, repair or replace it. Refer to GROUP 00E, Harness Connector Inspection [P.00E-2](#) .*

**Q: Are the harness wires between column switch connector C-60 and battery in good condition?**

**YES :** There is no action to be taken.

**NO :** Repair them. Confirm the DTC 12 is not displayed.

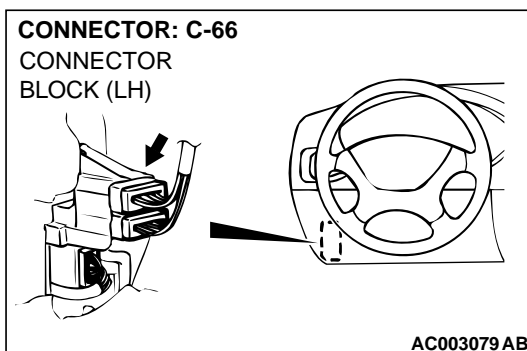

**STEP 5. Check the column switch ground circuit at the column switch connector C-60.**

- (1) Disconnect the column switch connector C-60 and measure at the harness side.
- (2) Measure the resistance between terminal 4 and ground.

**Q: Is the resistance less than 2 ohm?**

**YES :** Go to Step 8.

**NO :** Go to Step 6.

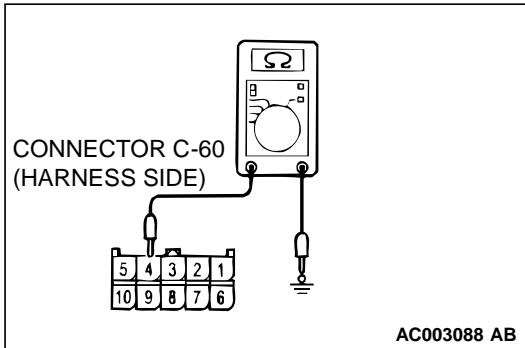

**STEP 6. Check column switch connector C-60 for damage.**

**Q: Is column switch connector C-60 in good condition?**

**YES :** Go to Step 7.

**NO :** Repair or replace it. Refer to GROUP 00E, Harness Connector Inspection [P.00E-2](#). Confirm the DTC 12 is not displayed.

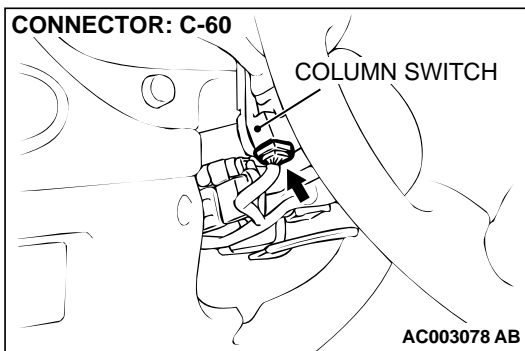

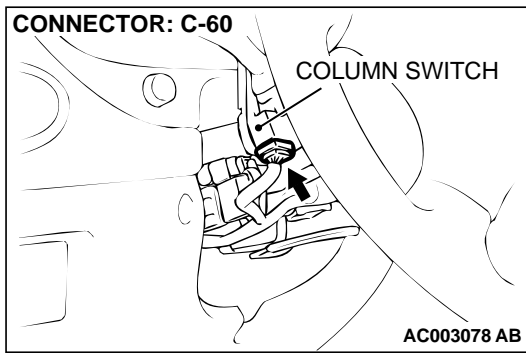

**STEP 7. Check the harness wires between column switch connector C-60 and ground.**

*NOTE: After checking junction block connectors C-73 and C-84, check the wires. If junction block connectors C-73 and C-84 are damaged, repair or replace them. Refer to GROUP 00E, Harness Connector Inspection P.00E-2.*

**Q: Are the harness wires between column switch connector C-60 and ground in good condition?**

**YES :** There is no action to be taken.

**NO :** Repair them. Confirm the DTC 12 is not displayed.

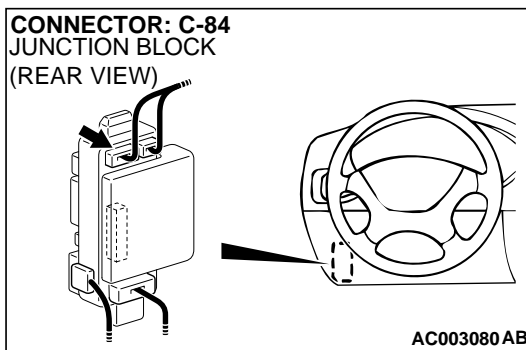
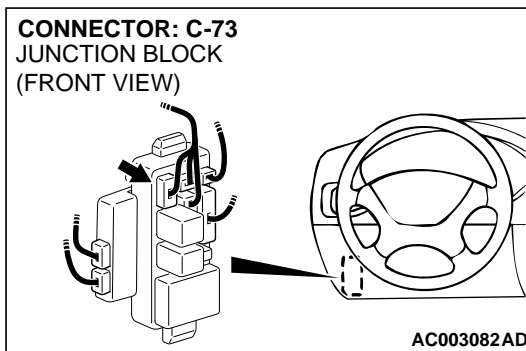



**STEP 8. Check the column switch connector C-60 and ETACS-ECU connector C-82 for damage.**

**Q: Are column switch connector C-60 and ETACS-ECU connector C-82 in good condition?**

**YES :** Go to Step 9.

**NO :** Repair or replace them. Refer to GROUP 00E, Harness Connector Inspection [P.00E-2](#) . Confirm the DTC 12 is not displayed.

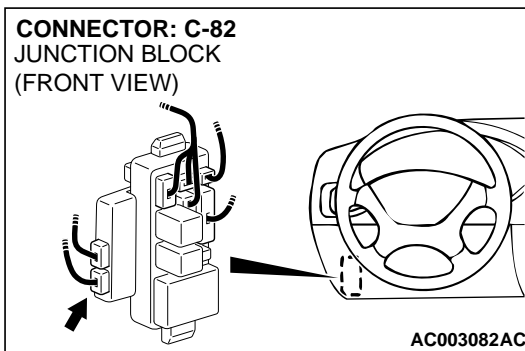
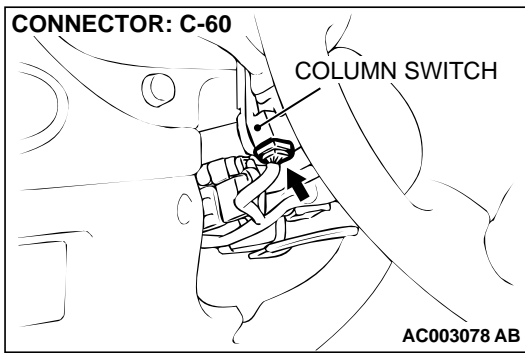

**STEP 9. Check the harness wires between column switch connector C-60 and ETACS-ECU connector C-82.**

**Q: Are the harness wires between column switch connector C-60 and ETACS-ECU connector C-82 in good condition?**

**YES :** Go to Step 10.

**NO :** Repair them. Confirm the DTC 12 is not displayed.

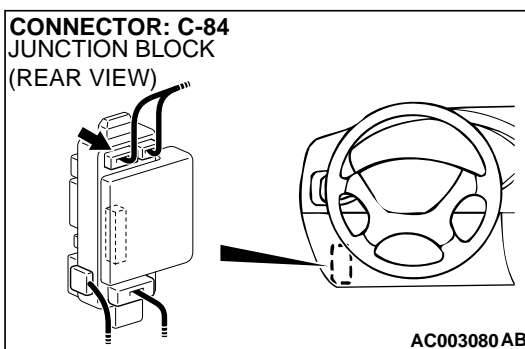
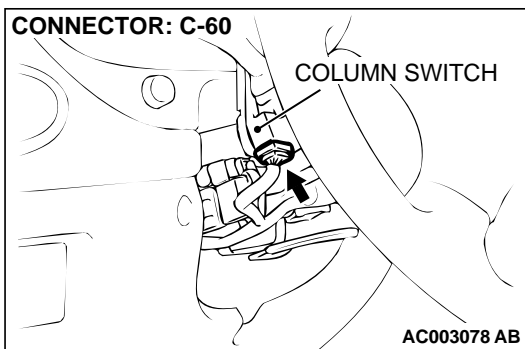

**STEP 10. Replacement of ECU.**

- (1) Replace the column switch.
- (2) Confirm the DTC 12 is not displayed.

**Q: Does DTC 12 set?**

**YES** : Replace the ETACS-ECU. Confirm the DTC 12 is not displayed.

**NO** : There is no action to taken.

**DTC 13: Front-ECU fault**

**Front-ECU Power Supply and SWS Communication Circuit**

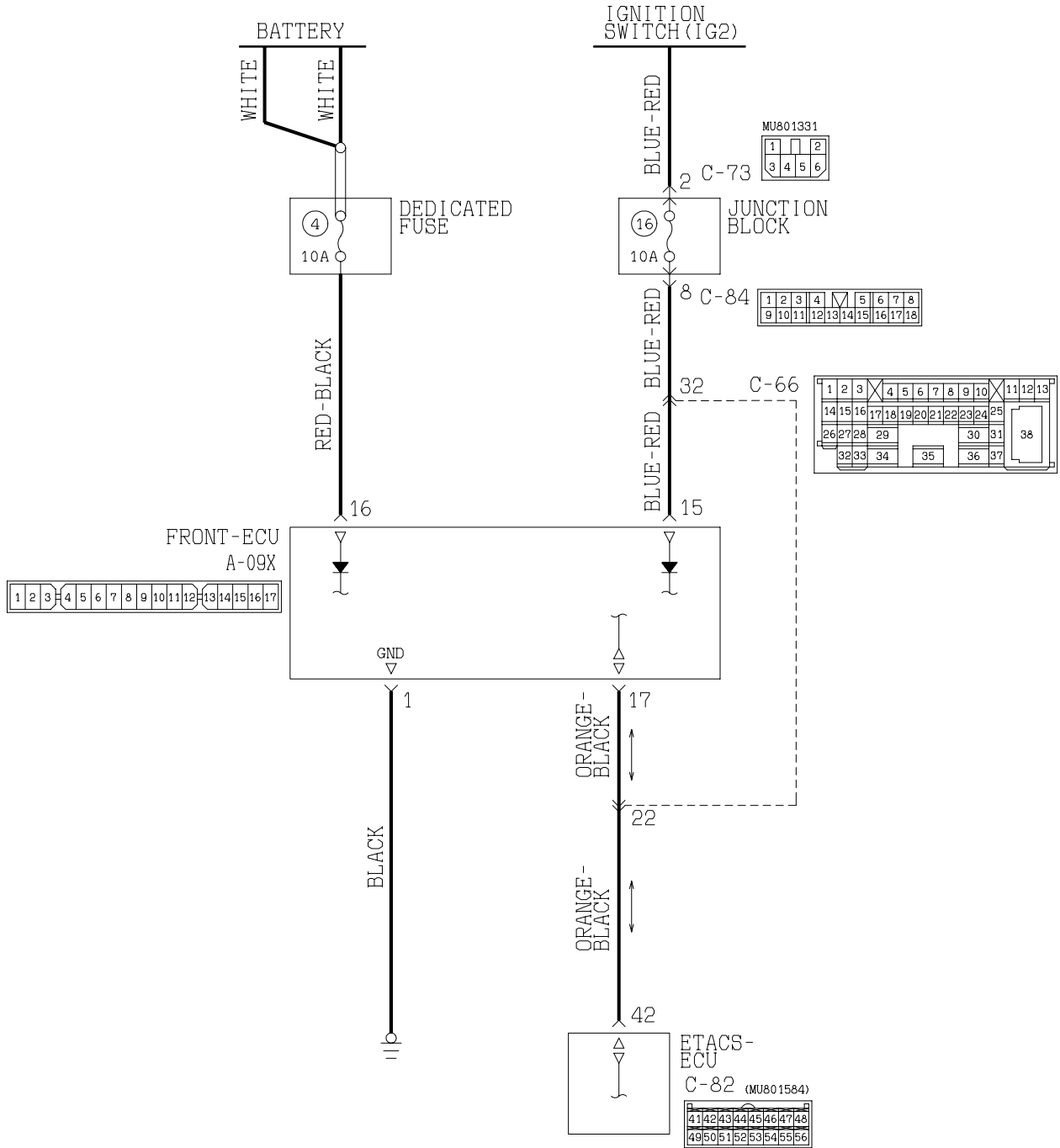

W1S09M01AA

**AC004199**

**TSB Revision**

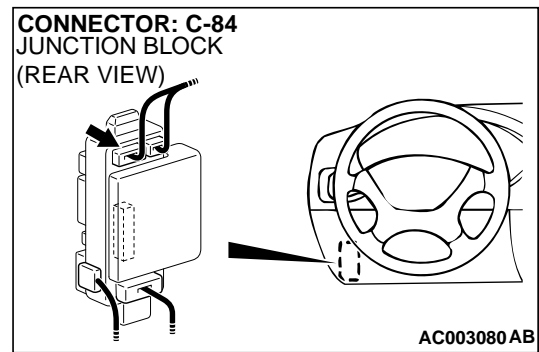
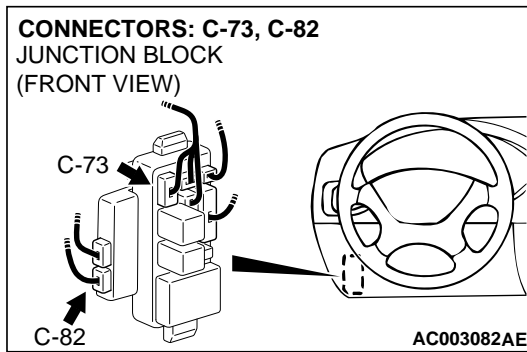
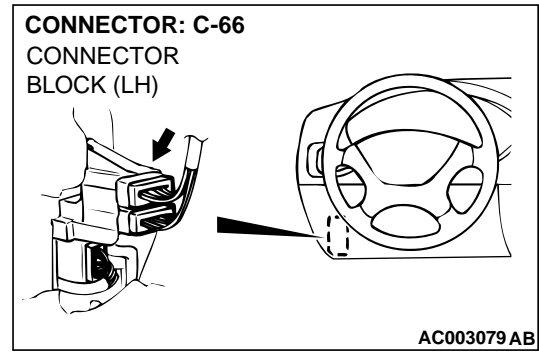
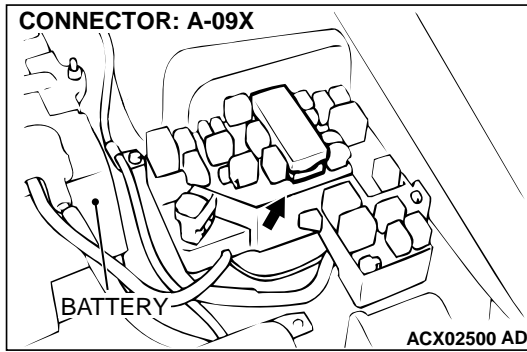

### CIRCUIT OPERATION

- The front-ECU is energized by the battery and the ignition switch (IG2). If one of the harness wires has an open circuit, power will be supplied by the other active harness wire.
- The front-ECU communicates with other ECUs and performs control functions through the SWS communication line.

### DTC SET CONDITION

This DTC is displayed when the front-ECU sends an abnormal signal to the ETACS-ECU.

### TROUBLESHOOTING HINTS

- Malfunction of the front-ECU
- Malfunction of the ETACS-ECU
- Damaged harness wires or connectors

### DIAGNOSIS

#### Required Special Tools:

- MB991223: Harness Set
- MB991502: Scan Tool (MUT-II)

#### STEP 1. Check the ignition switch position.

**Q: Does DTC 13 set with the ignition switch at "ON" position?**

**YES :** Go to Step 5.

**NO :** Go to Step 2.

**STEP 2. Check the front-ECU power supply circuit (battery circuit) at the front-ECU connector A-09X.**

- (1) Disconnect the front-ECU connector A-09X and measure at the relay box side.
- (2) Measure the voltage between terminal 16 and ground.

**Q: Is the voltage approximately 12 volts (battery positive voltage)?**

**YES :** Replace the front-ECU. Confirm the DTC 13 is not displayed.

**NO :** Go to Step 3.

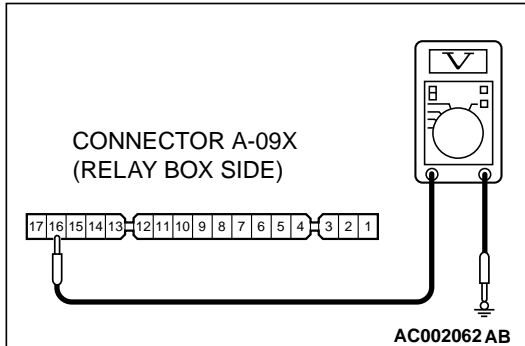

**STEP 3. Check the front-ECU connector A-09X for damage.**

**Q: Is front-ECU connector A-09X in good condition?**

**YES :** Go to Step 4.

**NO :** Repair or replace it. Refer to GROUP 00E, Harness Connector Inspection [P.00E-2](#) . Confirm the DTC 13 is not displayed.

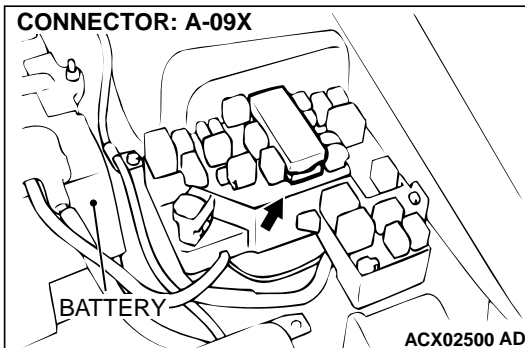

**STEP 4. Check the harness wire between front-ECU connector A-09X and battery.**

**Q: Is the harness wire between front-ECU connector A-09X and battery in good condition?**

**YES :** There is no action to be taken.

**NO :** Repair it. Confirm the DTC 13 is not displayed.

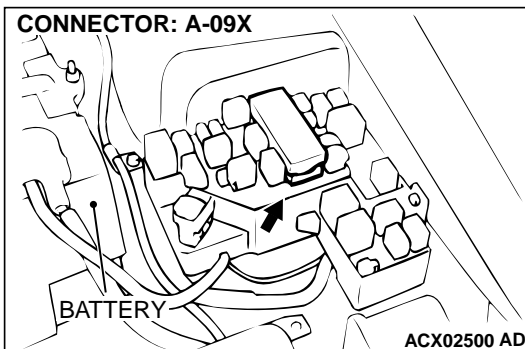

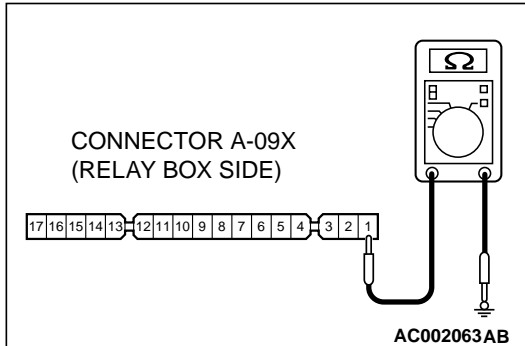

**STEP 5. Check the front-ECU ground circuit at the front-ECU connector A-09X.**

- (1) Disconnect the front-ECU connector A-09X and measure at the relay box side.
- (2) Measure the resistance between terminal 1 and ground.

**Q: Is the resistance less than 2 ohm?**

**YES :** Go to Step 8.

**NO :** Go to Step 6.

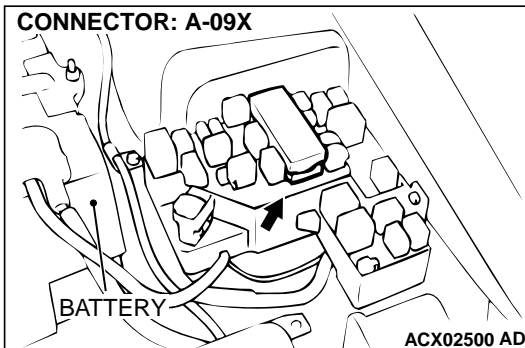

**STEP 6. Check the front-ECU connector A-09X for damage.**

**Q: Is front-ECU connector A-09X in good condition?**

**YES :** Go to Step 7.

**NO :** Repair or replace it. Refer to GROUP 00E, Harness Connector Inspection [P.00E-2](#) . Confirm the DTC 13 is not displayed.

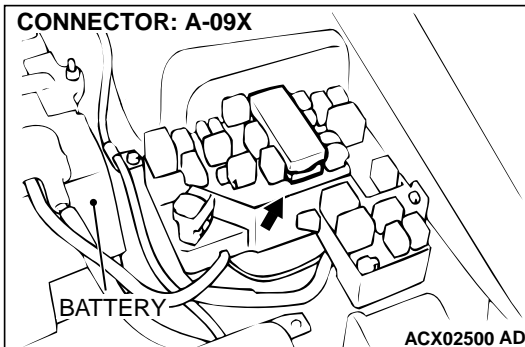

**STEP 7. Check the harness wire between front-ECU connector A-09X and ground.**

**Q: Is the harness wire between front-ECU connector A-09X and ground in good condition?**

**YES :** There is no action to be taken.

**NO :** Repair it. Confirm the DTC 13 is not displayed.

**STEP 8. Check front-ECU connector A-09X and ETACS-ECU connector C-82 for damage.**

**Q: Are front-ECU connector A-09X and ETACS-ECU connector C-82 in good condition?**

**YES :** Go to Step 9.

**NO :** Repair or replace them. Refer to GROUP 00E, Harness Connector Inspection [P.00E-2](#) . Confirm the DTC 13 is not displayed.

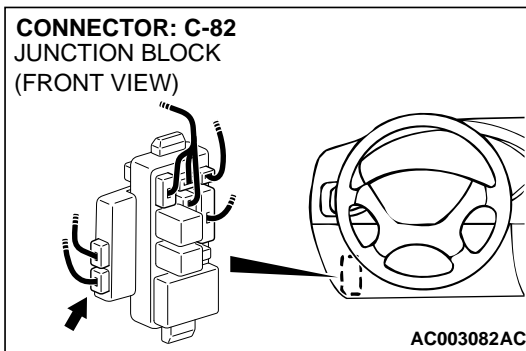
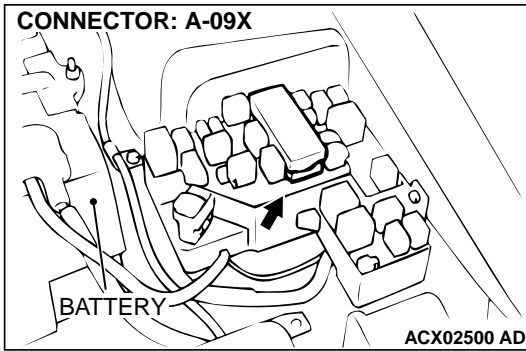

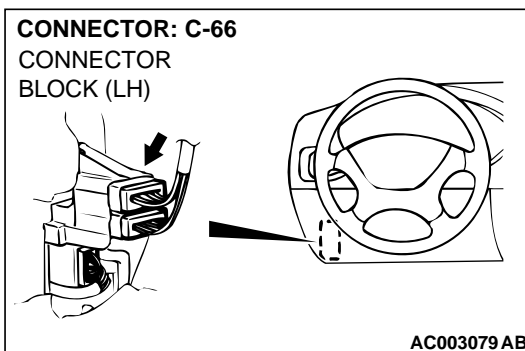
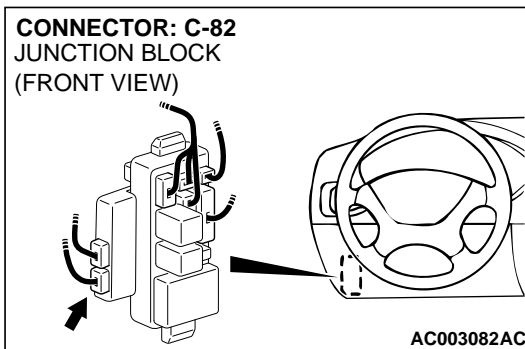
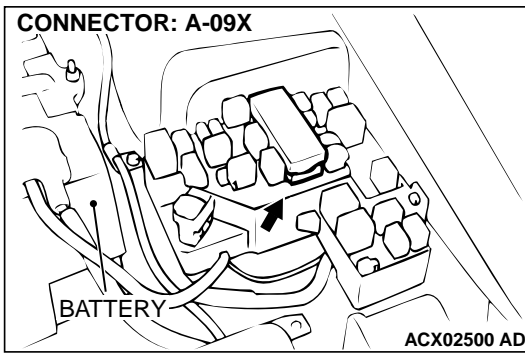

**STEP 9. Check the harness wires between front-ECU connector A-09X and ETACS-ECU connector C-82.**

*NOTE: After checking intermediate connector C-66, check the wires. If intermediate connector C-66 is damaged, repair or replace them. Refer to GROUP 00E, Harness Connector Inspection P.00E-2.*

**Q: Are the harness wires between front-ECU connector A-09X and ETACS-ECU connector C-82 in good condition?**

**YES :** Go to Step 10.

**NO :** Repair them. Confirm the DTC 13 is not displayed.

**STEP 10. Replacement of ECU.**

- (1) Replace the front-ECU.
- (2) Confirm the DTC 13 is not displayed.

**Q: Does DTC 13 set?**

**YES :** Replace the ETACS-ECU. Confirm the DTC 13 is not displayed.

**NO :** There is no action to taken.



**DTC 21: Short circuit communication line**

**SWS Communication Circuit**

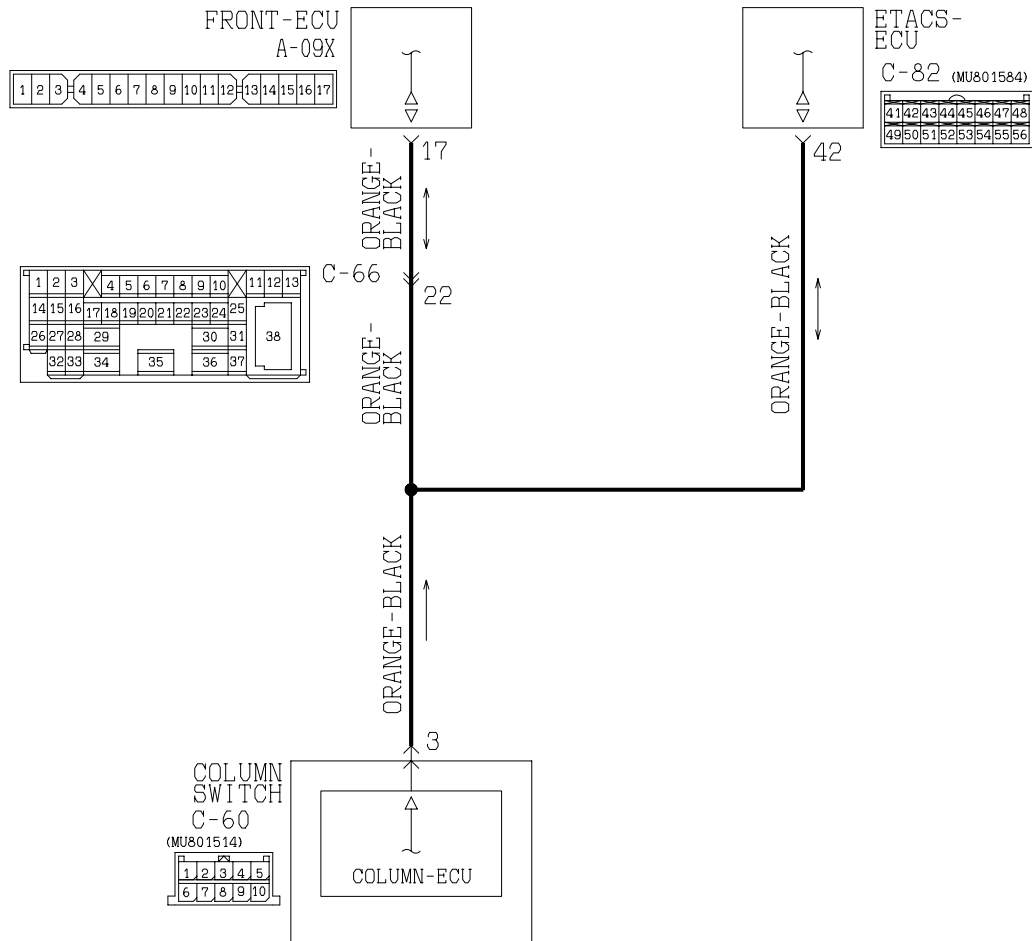

W1S09M02AA  
AC004200

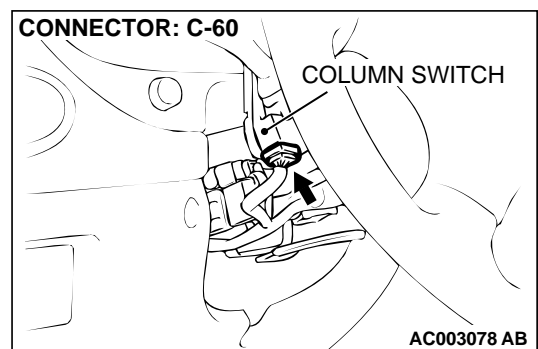
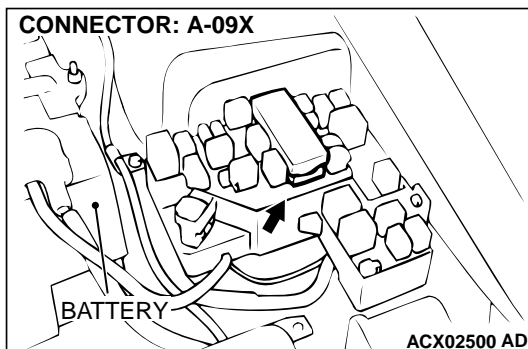

**TSB Revision**

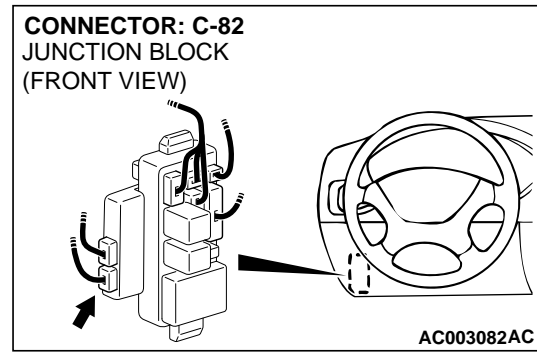
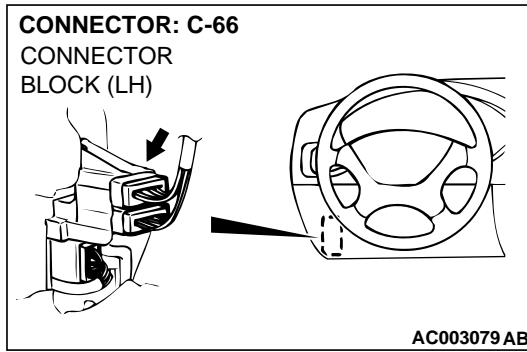

### DTC 21 SHORT CIRCUIT IN COMMUNICATION LINE

ETACS-ECU, column switch (incorporated in ECU) and front-ECU communicate with each other through the SWS communication line.

### DTC SET CONDITION

This DTC is displayed when the SWS communication line remains at low level for 0.3 seconds. No other DTC is displayed if DTC 21 is displayed.

### TROUBLESHOOTING HINTS

- Malfunction of the ETACS-ECU
- Malfunction of the column switch
- Malfunction of the front-ECU
- Damaged harness wires or connectors

### DIAGNOSIS

#### Required Special Tools:

- MB991223: Harness Set
- MB991502: Scan Tool (MUT-II)

**STEP 1.** Check the ETACS-ECU connector C-82, column switch connector C-60 and front-ECU connector A-09X for damage.

**Q:** Are ETACS-ECU connector C-82, column switch connector C-60 and front-ECU connector A-09X in good condition?

**YES :** Go to Step 2.

**NO :** Repair or replace them. Refer to GROUP 00E, Harness Connector Inspection [P.00E-2](#) . Confirm the DTC 21 is not displayed.

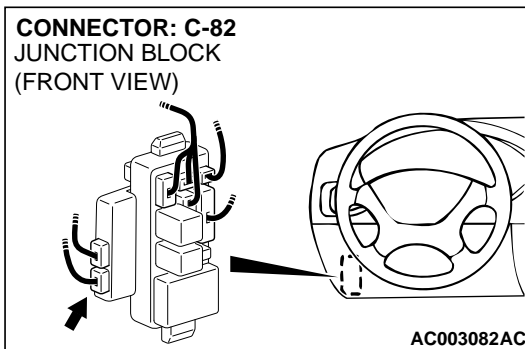
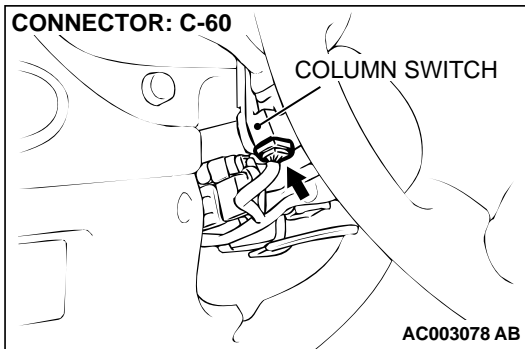
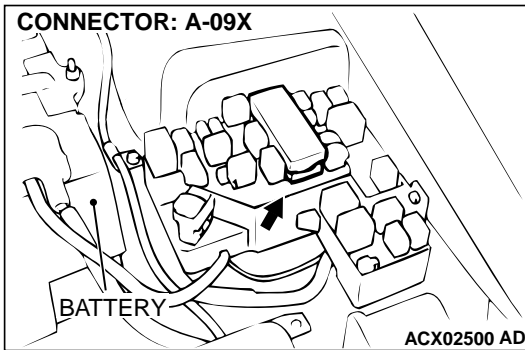

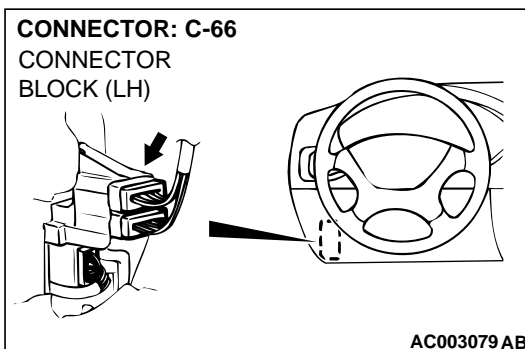
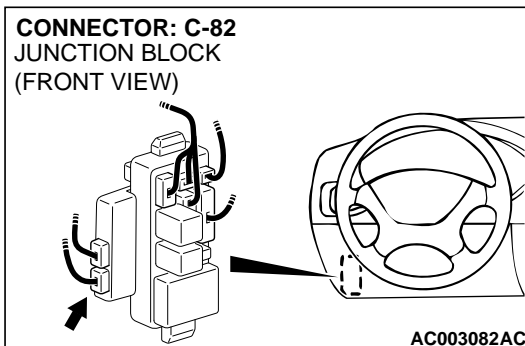
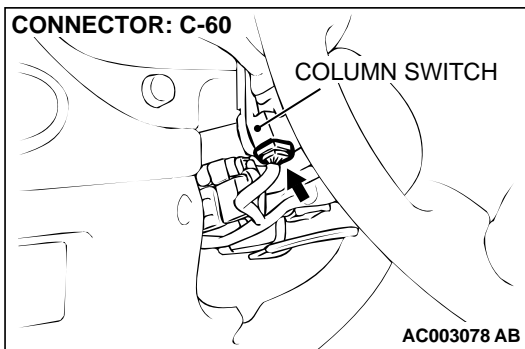
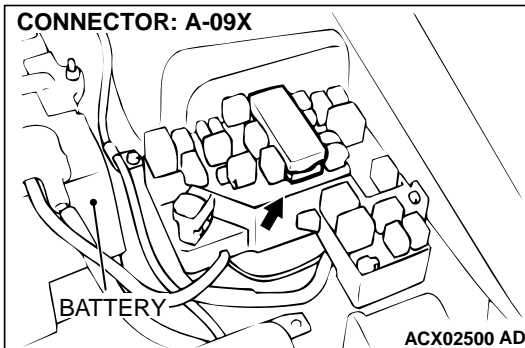

**STEP 2.** Check the harness wires from ETACS-ECU connector C-82 to column switch connector C-60 and front-ECU connector A-09X.

*NOTE:* After inspecting intermediate connectors C-66, check the wires. If intermediate connectors C-66 is damaged, repair or replace them. Refer to GROUP 00E, Harness Connector Inspection P.00E-2 .

**Q:** Are the harness wires from ETACS-ECU connector C-82 to column switch connector C-60 and front-ECU connector A-09X in good condition?

**YES :** Go to Step 3.

**NO :** Replace them. Confirm the DTC 21 is not displayed.

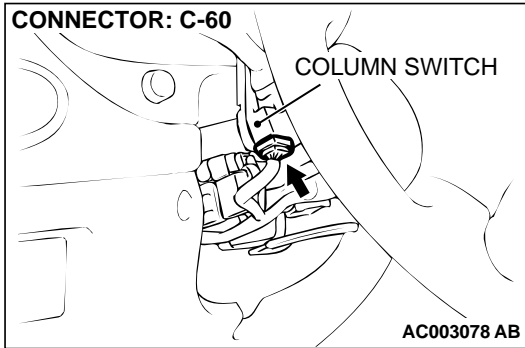

**STEP 3. Check the column switch.**

Disconnect column switch connector C-60.

**Q: Does DTC 21 set?**

**YES :** Go to Step 4.

**NO (DTC 12 sets) :** Replace the column switch. Confirm the DTCs 12 and 21 are not displayed.

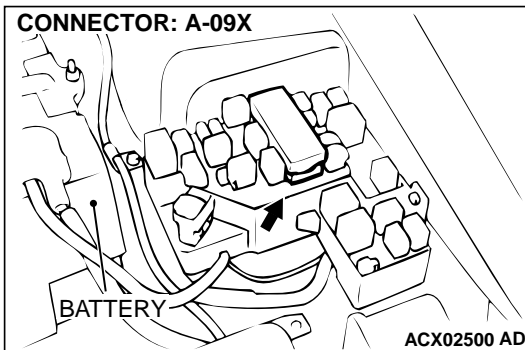

**STEP 4. Check the front-ECU.**

Disconnect front-ECU connector A-09X.

**Q: Does DTC 21 set?**

**YES :** Replace the ETACS-ECU. Confirm the DTC 21 is not displayed..

**NO (DTC 13 sets) :** Replace the front-ECU. Confirm the DTCs 13 and 21 are not displayed.

SYMPTOM PROCEDURES

Inspection Procedure A-1: Scan tool MB991502 communication is not possible.

ETACS-ECU Power Supply and Scan Tool Communication Circuit

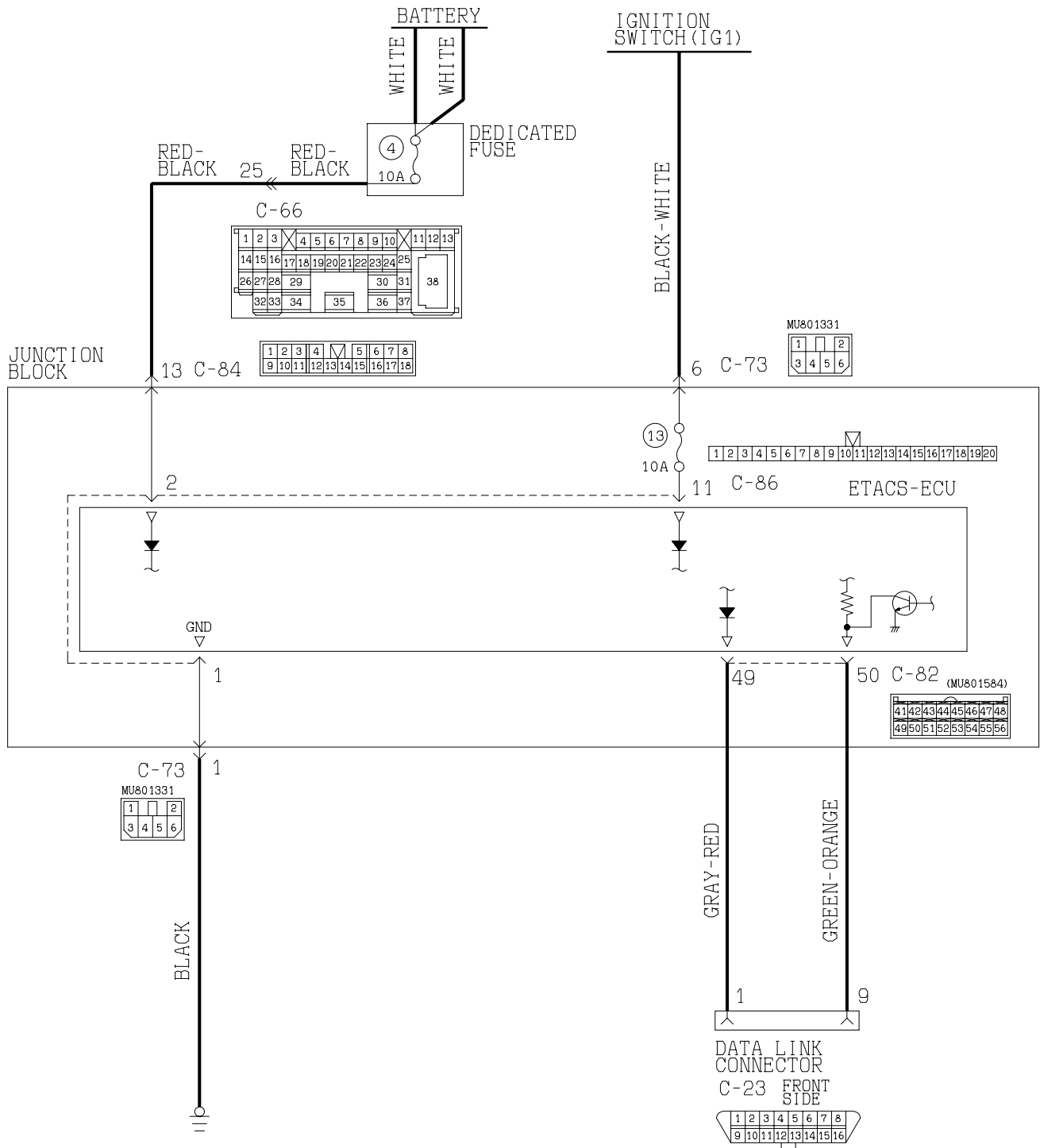

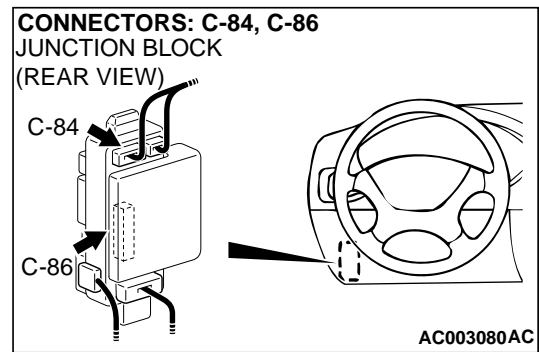
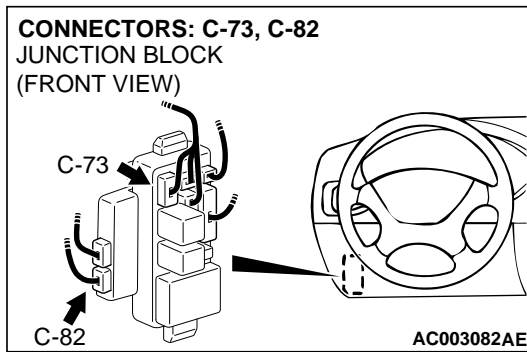
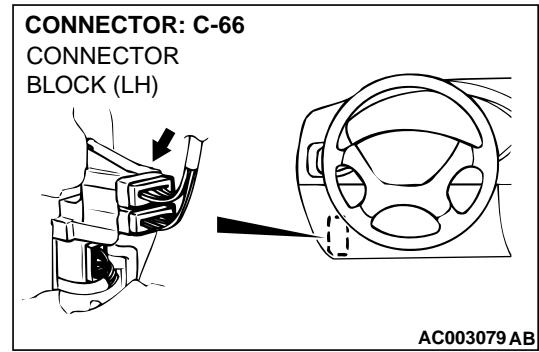
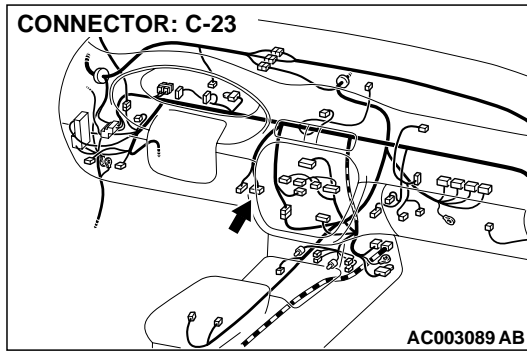

**SCAN TOOL MB991502 COMMUNICATION IS NOT POSSIBLE**

The ETACS-ECU receives a diagnostic trouble code and switch signals from the data link connector.

**TECHNICAL DESCRIPTION (COMMENT)**

The harness wires between the ETACS-ECU power supply line or the ETACS-ECU and the data link connector may be defective.

**TROUBLESHOOTING HINTS**

- Malfunction of the ETACS-ECU
- Damaged harness wires or connectors

**DIAGNOSIS**

**Required Special Tools:**

- MB991223: Test Harness Set
- MB991502: Scan Tool (MUT-II)

**STEP 1. Check the communication with other systems.**

**Q: Can the scan tool communicate with no systems?**

**YES :** Refer to GROUP 13A, Diagnosis [P.13A-20](#) or GROUP 13B, Diagnosis.

**NO (can not communicate with SWS only :** Go to Step 2.

**STEP 2. Check the ignition switch positions.**

**Q: Can scan tool MB991502 communicate with the ETACS-ECU with the ignition switch at any position other than "ON?"**

**YES :** Go to Step 3.

**NO :** Check the ETACS-ECU battery circuits. Refer to Inspection Procedure O-1 ([P.54B-266](#) ).

CONNECTOR: C-23

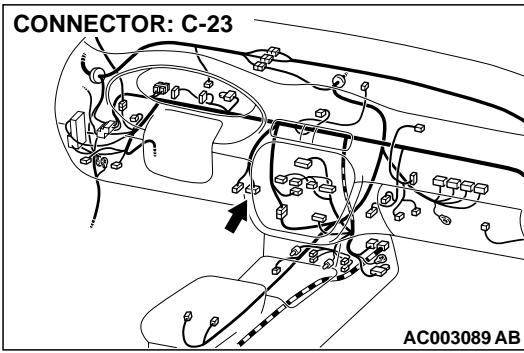

CONNECTOR: C-82  
JUNCTION BLOCK  
(FRONT VIEW)

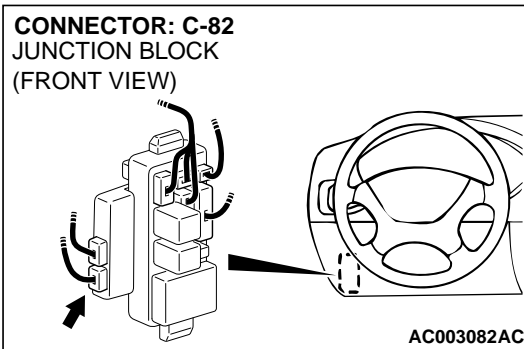

CONNECTOR: C-23

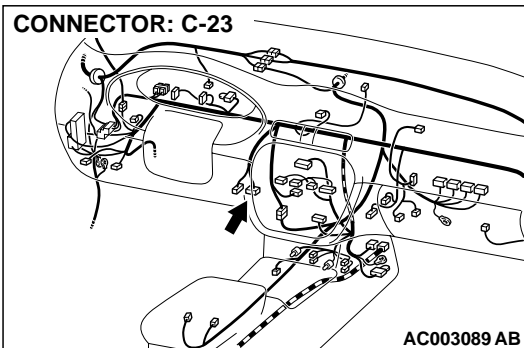

CONNECTOR C-86  
(JUNCTION BLOCK SIDE)

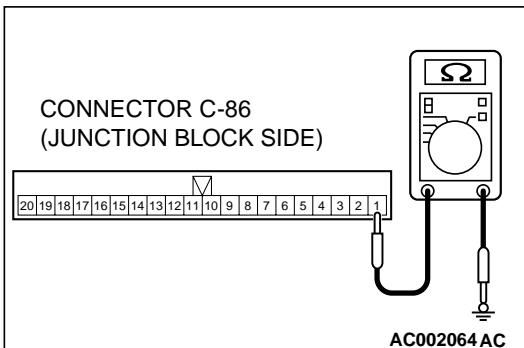

**STEP 3. Check data link connector C-23 and ETACS-ECU connector C-82 for damage.**

**Q: Are data link connector C-23 and ETACS-ECU connector C-82 in good condition?**

**YES :** Go to Step 4.

**NO :** Repair or replace them. Refer to GROUP 00E, Harness Connector Inspection [P.00E-2](#) . Scan tool MB991502 should communicate with the SWS.

**STEP 4. Check the harness wires between data link connector C-23 and ETACS-ECU connector C-82.**

**Q: Are the harness wires between data link connector C-23 and ETACS-ECU connector C-82 in good condition?**

**YES :** Go to Step 5.

**NO :** Repair them. Scan tool MB991502 should communicate with the SWS.

**STEP 5. Check the ETACS-ECU ground circuit at the ETACS-ECU connector C-86.**

(1) Disconnect the ETACS-ECU connector C-86 and measure at the junction block side.

(2) Measure the resistance between terminal 1 and ground.

**Q: Is the resistance less than 2 ohm?**

**YES :** Replace the ETACS-ECU. Scan tool MB991502 should communicate with the SWS.

**NO :** Go to Step 6.



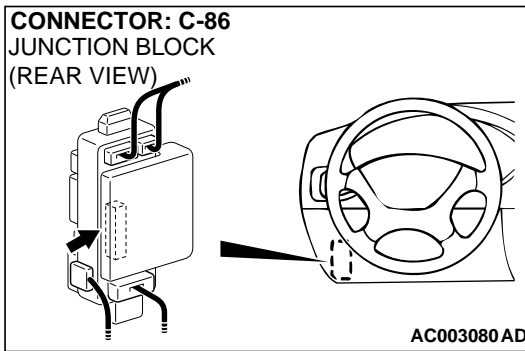

**STEP 6. Check the ETACS-ECU connector C-86 for damage.**

**Q: Is ETACS-ECU connector C-86 in good condition?**

**YES :** Go to Step 7.

**NO :** Repair or replace it. Refer to GROUP 00E, Harness Connector Inspection [P.00E-2](#) . Scan tool MB991502 should communicate with the SWS.

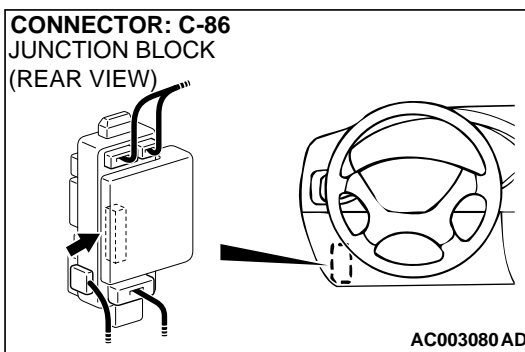

**STEP 7. Check the harness wires between ETACS-ECU connector C-86 and ground.**

**NOTE:** After checking junction block connector C-73, check the wires. If junction block connector C-73 is damaged, repair or replace it. Refer to GROUP 00E, Harness Connector Inspection [P.00E-2](#) .

**Q: Are the harness wires between ETACS-ECU connector C-86 and ground in good condition?**

**YES :** There is no action to be taken.

**NO :** Repair them. Scan tool MB991502 should communicate with the SWS.

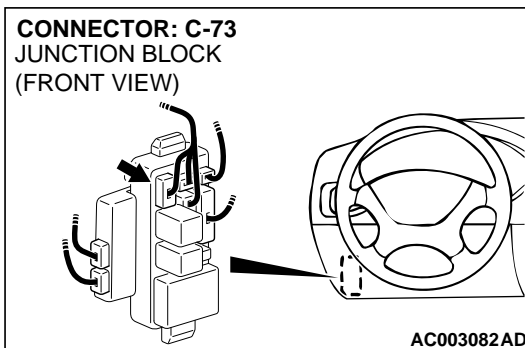

**Inspection Procedure B-1: Tone alarm: Ignition key reminder tone alarm function does not work normally.**

**TECHNICAL DESCRIPTION (COMMENT)**

The ETACS-ECU operates the ignition key reminder tone alarm function, based on input signals from the following switches:

- Ignition switch (IG1)
- Key reminder switch
- Driver's door switch

If the function does not work normally, a defect on the relevant circuit or the ETACS-ECU may be suspected.

**TROUBLESHOOTING HINTS**

- Malfunction of the key reminder switch
- Malfunction of the driver's door switch
- Malfunction of the ETACS-ECU
- Damaged harness wires or connectors

**DIAGNOSIS****Required Special Tools:**

- MB991502: Scan Tool (MUT-II)
- MB991529: Diagnostic Trouble Code Check Harness

**STEP 1. Check the ETACS-ECU power supply circuit.**

If the ignition switch is at "LOCK" (OFF) position, do all of the following functions operate?

- Light reminder tone alarm function
- Central door locking system
- Hazard warning light
- Interior light dimming function
- Theft-alarm system

**Q: Does any function described above operate?**

**YES** : Go to Step 2 <when using scan tool MB991502> or 3 <when using a voltmeter>.

**NO** : Check the ETACS-ECU battery circuit. Refer to Inspection Procedure O-1 (P.54B-266 ).

**STEP 2. Check the input signal (by using scan tool MB991502).**

Check the input signals from the following switches:

- Ignition switch (IG1)
- Key reminder switch
- Driver's door switch

**⚠ CAUTION**

**To prevent damage to scan tool MB991502, always turn the ignition switch to the "LOCK" (OFF) position before connecting or disconnecting scan tool MB991502.**

- (1) Connect scan tool MB991502 to the data link connector.
- (2) Check that the tone alarm of scan tool MB991502 sounds when the input signal enters.

**Q: Does the tone alarm of scan tool MB991502 sound when the input signal enters?**

**YES** : Replace the ETACS-ECU. The ignition key reminder tone alarm function should work normally.

**NO** : Check the relevant input circuit. Refer to P.54B-9.

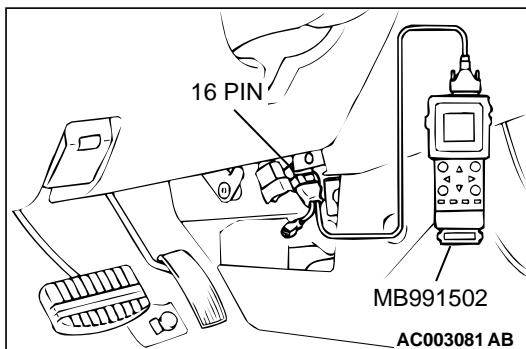

**STEP 3. Check the input signal (by using a voltmeter).**

Check the input signals from the following switches:

- Ignition switch (IG1)
- Key reminder switch
- Driver's door switch

- (1) Use special tool MB991529 to connect a voltmeter between ground terminal 4 or 5 and ETACS-ECU terminal 9 of the data link connector.
- (2) Check that the voltmeter indicator deflects once when the input signal enters.

**Q: Does the voltmeter indicator deflect?**

**YES :** Replace the ETACS-ECU. The ignition key reminder tone alarm function should work normally.

**NO :** Check the relevant input circuit. Refer to [P.54B-9](#).

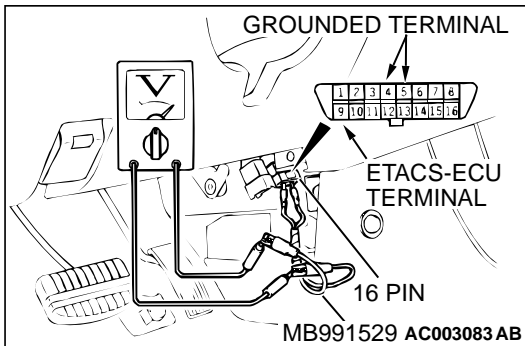

**Inspection Procedure B-2: Tone alarm: Light reminder tone alarm function does not work normally.**

**TECHNICAL DESCRIPTION (COMMENT)**

The ETACS-ECU operates the light reminder tone alarm function, based on input signals from the following switches and the front-ECU:

- Ignition switch (IG1)
- Driver's door switch
- Taillight switch
- Headlight switch

If the function does not work normally, a defect on the relevant circuit or the ETACS-ECU may be suspected.

**TROUBLESHOOTING HINTS**

- Malfunction of the driver's door switch
- Malfunction of the column switch (turn-signal light and lighting switch)
- Malfunction of the ETACS-ECU
- Damaged harness wires or connectors

**DIAGNOSIS**

**Required Special Tools:**

- MB991502: Scan Tool (MUT-II)
- MB991529: Diagnostic Trouble Code Check Harness

**STEP 1. Check the ETACS-ECU power supply circuit.**

If the ignition switch is at "LOCK" (OFF) position, do all of the following functions operate?

- Ignition key reminder tone alarm function
- Central door locking system
- Hazard warning light
- Interior light dimming function
- Theft-alarm system

**Q: Do any functions described above operate?**

**YES :** Go to Step 2 <when using scan tool MB991502> or 3 <when using a voltmeter>.

**NO :** Check the ETACS-ECU battery circuit. Refer to Inspection Procedure O-1 ([P.54B-266](#)).

**STEP 2. Check the input signal (by using scan tool MB991502).**

Check the input signals from the following switches:

- Ignition switch (IG1)
- Driver's door switch
- Taillight switch
- Headlight switch

**⚠ CAUTION**

To prevent damage to scan tool MB991502, always turn the ignition switch to the "LOCK" (OFF) position before connecting or disconnecting scan tool MB991502.

- (1) Connect scan tool MB991502 to the data link connector.
- (2) Check that the tone alarm of scan tool MB991502 sounds when the input signal enters.

**Q: Does the tone alarm of scan tool MB991502 sound when the input signal enters**

- YES :** Replace the ETACS-ECU. The light reminder tone alarm function should work normally.
- NO :** Check the relevant input circuit. Refer to [P.54B-9](#).

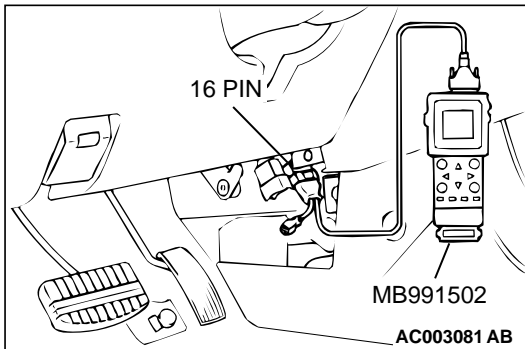

**STEP 3. Check the input signal (by using a voltmeter).**

Check the input signals from the following switches:

- Ignition switch (IG1)
- Driver's door switch
- Taillight switch
- Headlight switch

- (1) Use special tool MB991529 to connect a voltmeter between ground terminal 4 or 5 and ETACS-ECU terminal 9 of the data link connector.
- (2) Check that the voltmeter indicator deflects once when the input signal enters.

**Q: Does the voltmeter indicator deflect?**

- YES :** Replace the ETACS-ECU. The light reminder tone alarm function should work normally.
- NO :** Check the relevant input circuit. Refer to [P.54B-9](#).

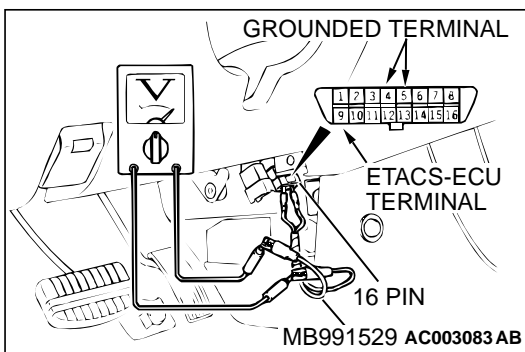

**Inspection Procedure B-3: Tone alarm: Seat belt tone alarm function does not work normally.**

**TECHNICAL DESCRIPTION (COMMENT)**

The ETACS-ECU operates the seat belt tone alarm function, based on input signals from the following switches and the front-ECU:

- Ignition switch (IG1)
- Driver's seat belt switch

If the function does not work normally, a defect on the relevant circuit or the ETACS-ECU may be suspected.

**TROUBLESHOOTING HINTS**

- Malfunction of the seat belt switch
- Malfunction of the ETACS-ECU
- Damaged harness wires or connectors

## DIAGNOSIS

### Required Special Tools:

- MB991502: Scan Tool (MUT-II)
- MB991529: Diagnostic Trouble Code Check Harness

---

### STEP 1. Check the ETACS-ECU power supply circuit.

If the ignition switch is at "LOCK" (OFF) position, do all of the following functions operate?

- Ignition key reminder tone alarm function
- Central door locking system
- Hazard warning light
- Interior light dimming function
- Theft-alarm system

### Q: Do any functions described above operate?

**YES** : Go to Step 2 <when using scan tool MB991502> or 3 <when using a voltmeter>.

**NO** : Check the ETACS-ECU battery circuit. Refer to Inspection Procedure O-1 (P.54B-266 ).

---

### STEP 2. Check the input signal (by using scan tool MB991502).

Check the input signals from the following switches:

- Ignition switch (IG1)
- Driver's seat belt switch
- Taillight switch
- Headlight switch

### **CAUTION**

To prevent damage to scan tool MB991502, always turn the ignition switch to the "LOCK" (OFF) position before connecting or disconnecting scan tool MB991502.

- (1) Connect scan tool MB991502 to the data link connector.
- (2) Check that the tone alarm of scan tool MB991502 sounds when the input signal enters.

### Q: Does the tone alarm of scan tool MB991502 sound when the input signal enters

**YES** : Replace the ETACS-ECU. The seat belt tone alarm function should work normally.

**NO** : Check the relevant input circuit. Refer to P.54B-9.

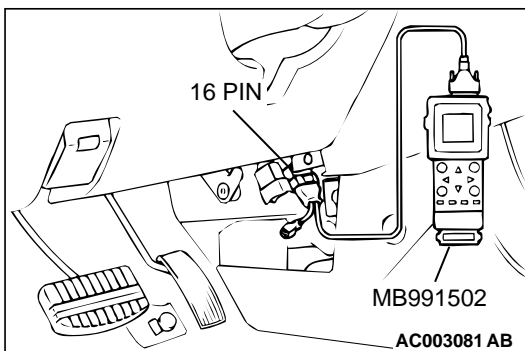

**STEP 3. Check the input signal (by using a voltmeter).**

Check the input signals from the following switches:

- Ignition switch (IG1)
- Driver's door switch
- Taillight switch
- Headlight switch

- (1) Use special tool MB991529 to connect a voltmeter between ground terminal 4 or 5 and ETACS-ECU terminal 9 of the data link connector.
- (2) Check that the voltmeter indicator deflects once when the input signal enters.

**Q: Does the voltmeter indicator deflect?**

**YES** : Replace the ETACS-ECU. The light reminder tone alarm function should work normally.

**NO** : Check the relevant input circuit. Refer to [P.54B-9](#).

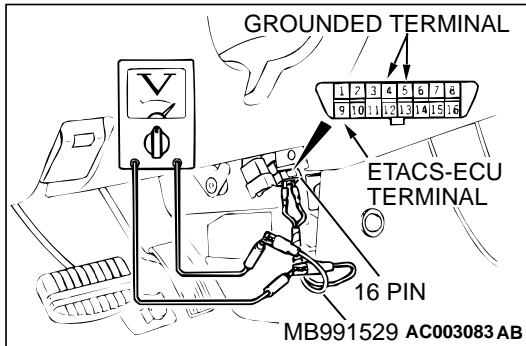

Inspection Procedure C-1: Central door locking system: Central door locking system does not operate.

Door Lock Actuator Circuit <1999 Models>

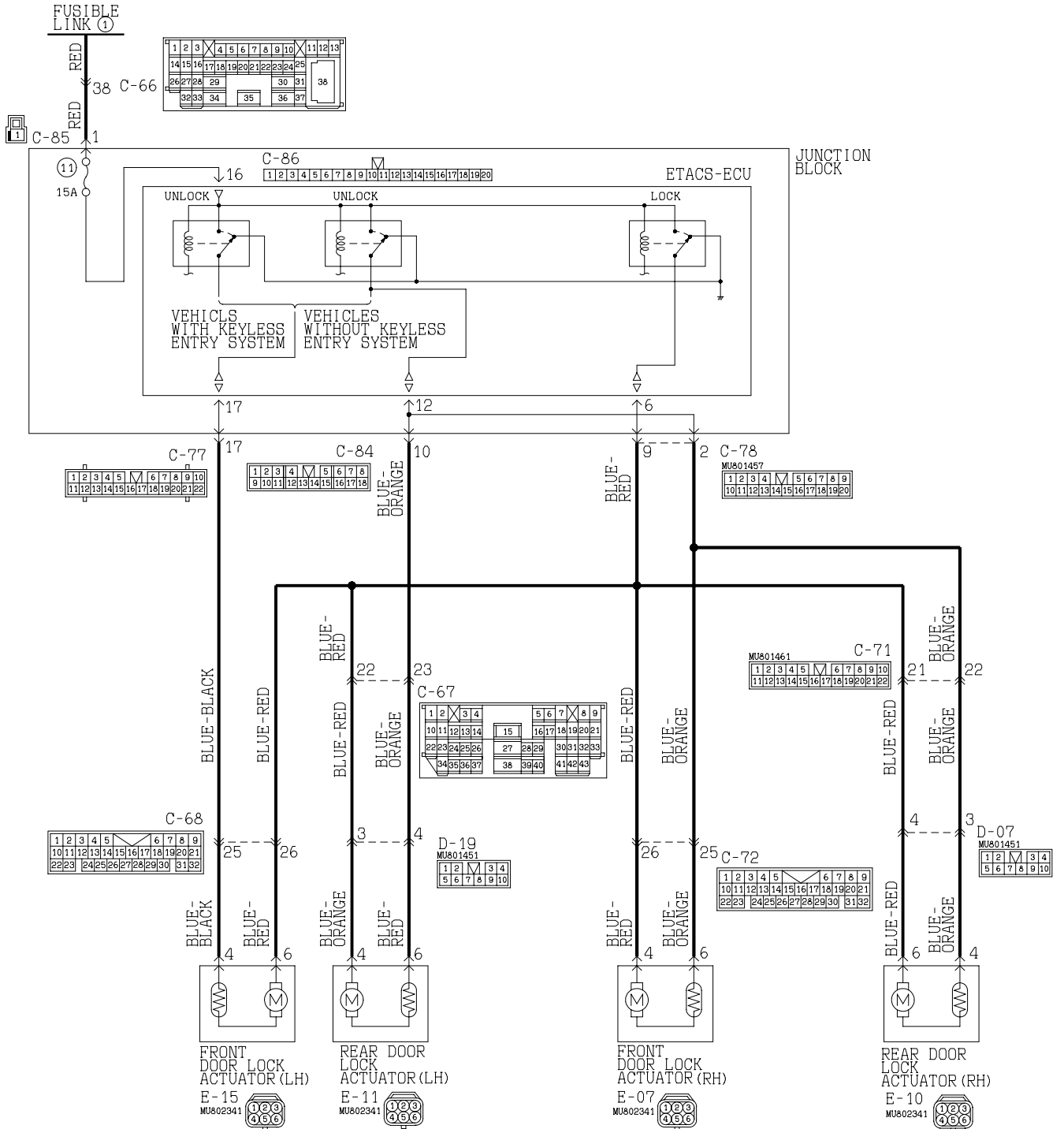

W1809M04AA

AC004202

TSB Revision

Door Lock Actuator Circuit <2000 Models>

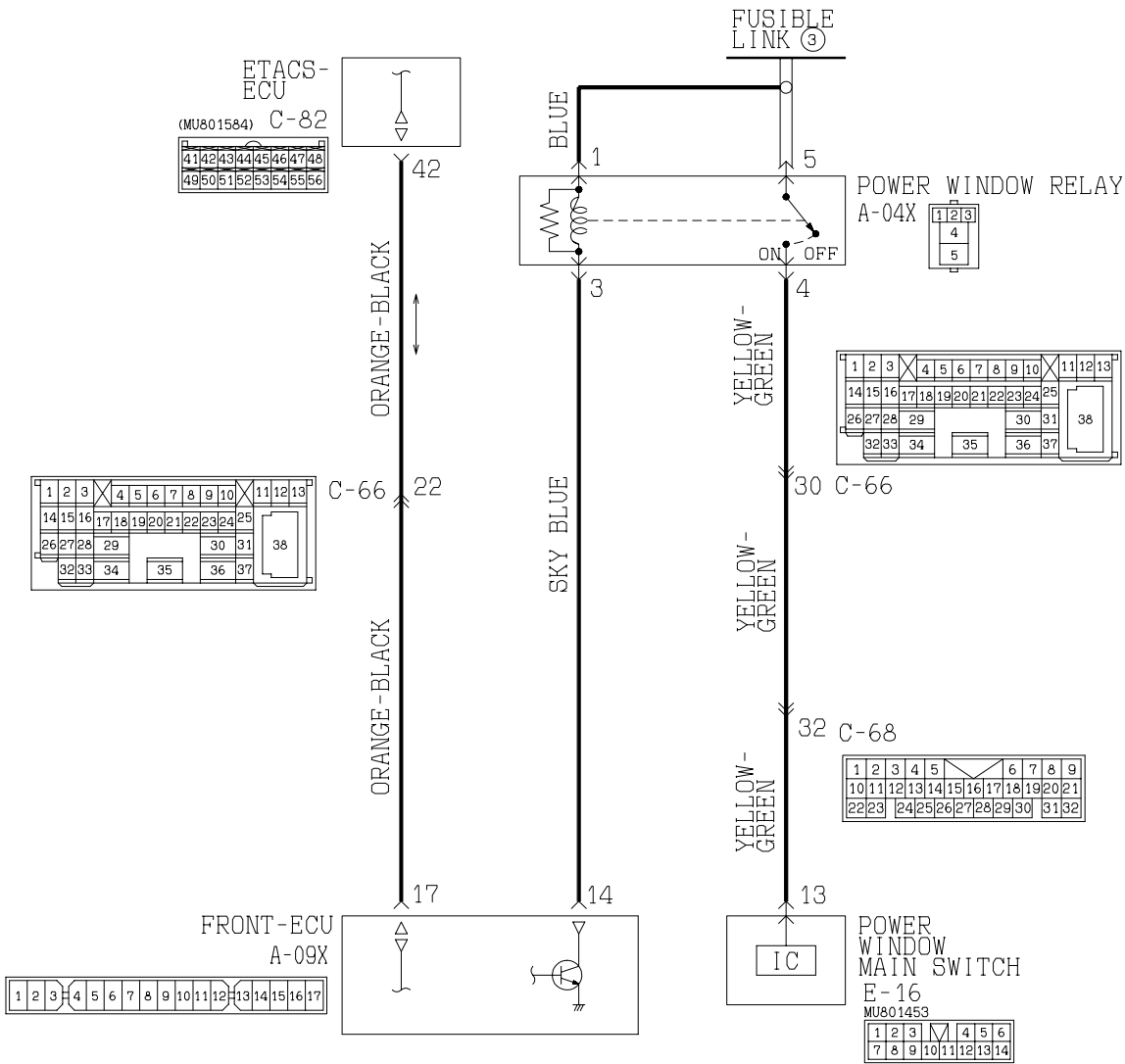

W1809M05AA

AC004203

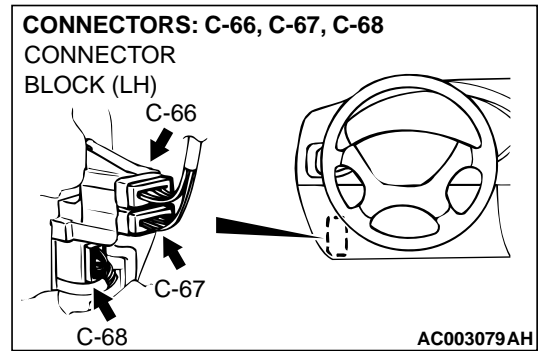
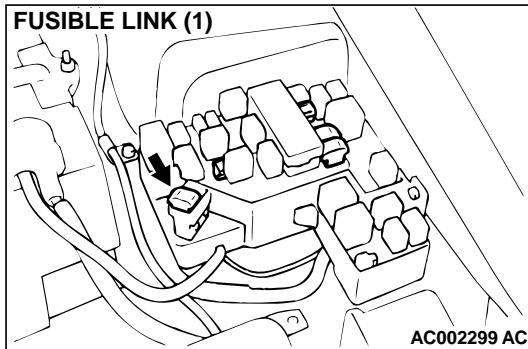



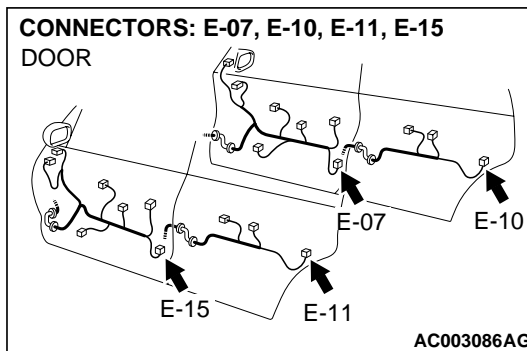
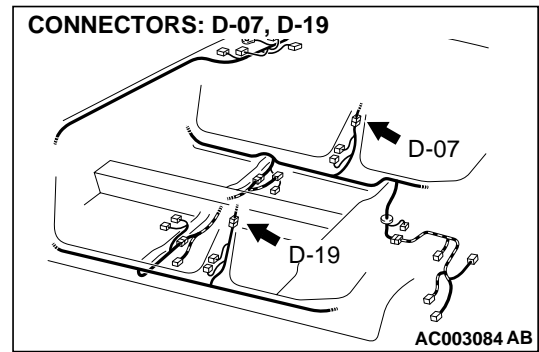
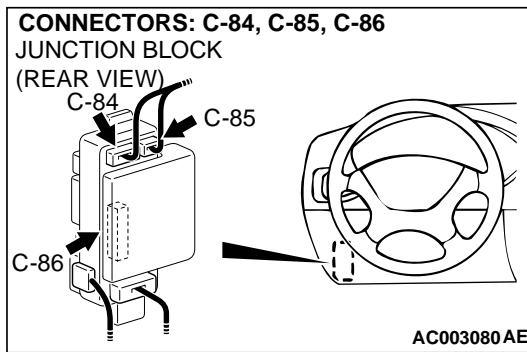
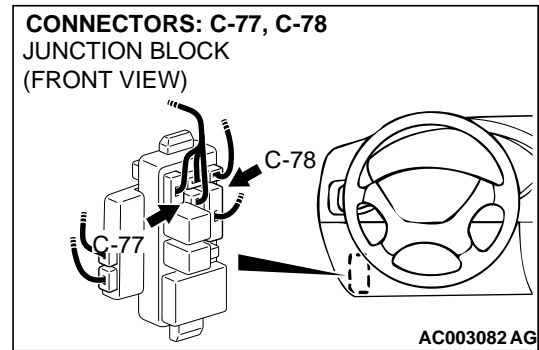
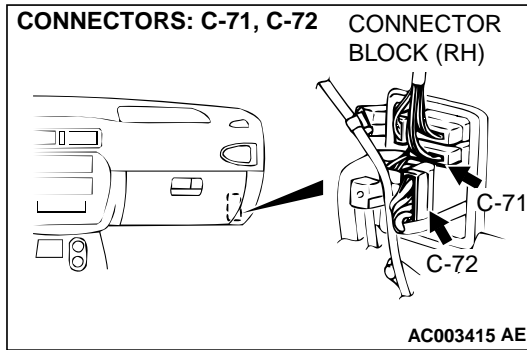

**CIRCUIT OPERATE**

- The ETACS-ECU operates the door lock actuators through its dedicated relay (integrated in the ETACS-ECU).
- The ETACS-ECU drives the relay to lock or unlock the door if the requirements are satisfied.

**TECHNICAL DESCRIPTION (COMMENT)**

The power supply circuit, the circuit shared by door lock actuators, or the ETACS-ECU may be defective.

**TROUBLESHOOTING HINTS**

- Malfunction of the ETACS-ECU
- Damaged harness wires or connectors

**DIAGNOSIS**

**Required Special Tool:**

- MB991223: Harness Set

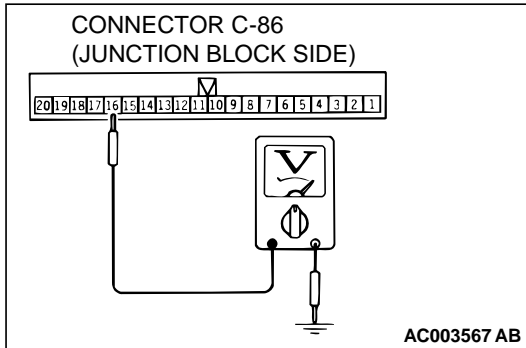

**STEP 1. Check the ETACS-ECU power supply circuit (fusible link (1) ) at the ETACS- ECU connector C-86.**

- (1) Disconnect the ETACS-ECU connector C-86 and measure at the junction block side.
- (2) Measure the voltage between terminal 16 and ground.

**Q: Is the voltage approximately 12 volts (battery positive voltage)?**

- YES :** Go to Step 4.  
**NO :** Go to Step 2.

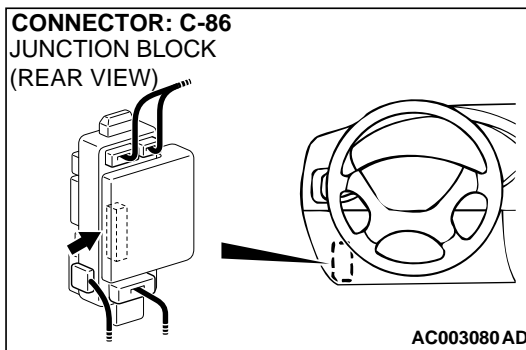

**STEP 2. Check the junction block connector C-86 for damage.**

**Q: Is junction block connector C-86 in good condition?**

- YES :** Go to Step 3.  
**NO :** Repair or replace it. Refer to GROUP 00E, Harness Connector Inspection [P.00E-2](#) . The central door locking system should work normally.

**STEP 3. Check the harness wires between ETACS-ECU connector C-86 and fusible link (1).**

*NOTE: After checking junction block connector C-85 and intermediate connector C-66, check the wires. If junction block connector C-85 and intermediate connector C-66 are damaged, repair or replace them. Refer to GROUP 00E, Harness Connector Inspection P.00E-2 .*

**Q: Are the harness wires between ETACS-ECU connector C-86 and fusible link (1) in good condition?**

**YES :** There is no action to be taken.

**NO :** Repair them. The central door locking system should work normally.

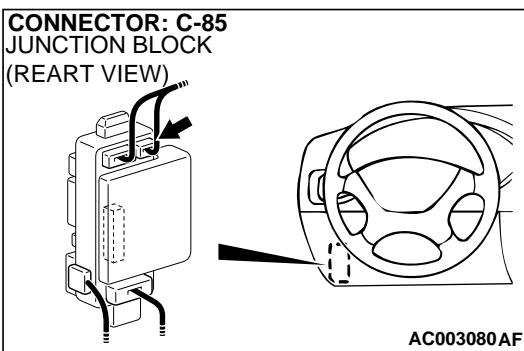
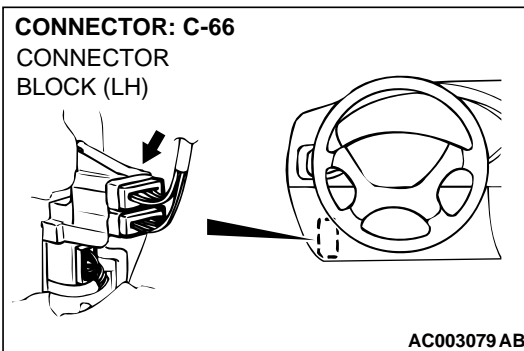
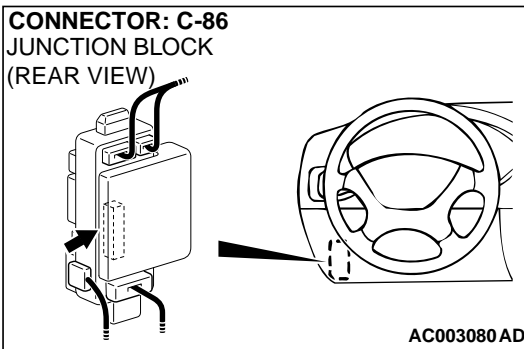
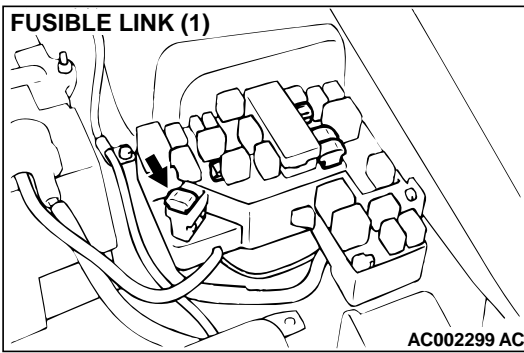

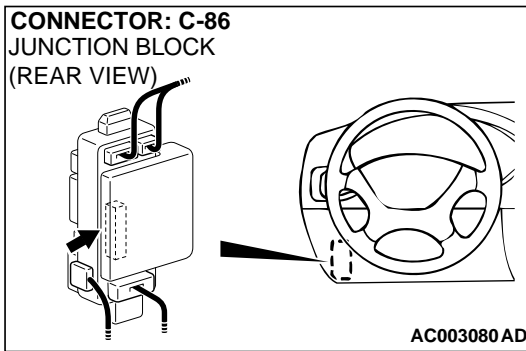

**STEP 4. Check the junction block connector C-86 for damage.**

**Q: Is junction block connector C-86 in good condition?**

**YES :** Go to Step 5.

**NO :** Repair or replace it. Refer to GROUP 00E, Harness Connector Inspection [P.00E-2](#) . The central door locking system should work normally.

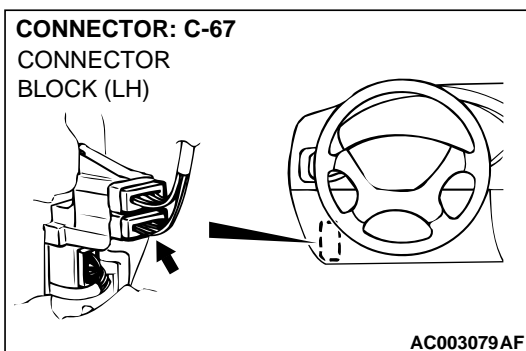

**STEP 5. Check the harness wires between ETACS-ECU connector C-86 and intermediate connector C-67.**

**NOTE:** After checking junction block connectors C-84 , check the wires. If junction block connectors C-84 is damaged, repair or replace them. Refer to GROUP 00E, Harness Connector Inspection [P.00E-2](#) .

**Q: Are the harness wires between ETACS-ECU connector C-86 and intermediate connector C-67 in good condition?**

**YES :** Replace the ETACS-ECU. The central door locking system should work normally.

**NO :** Repair them. The central door locking system should work normally.

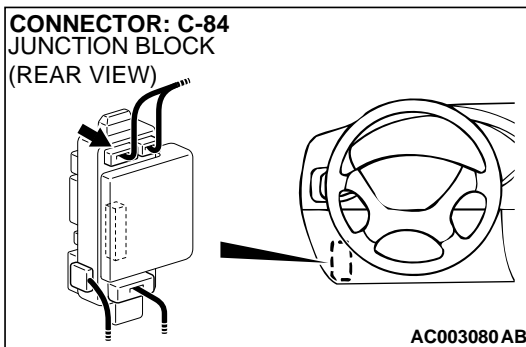
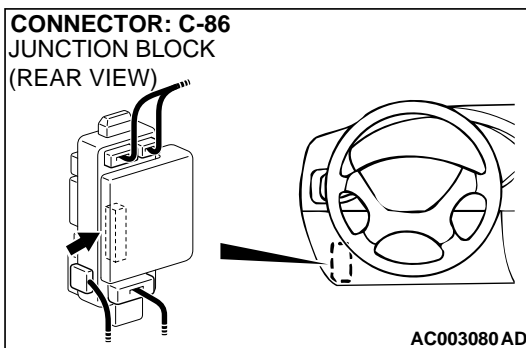

**Inspection Procedure C-2: Central door locking system: Some doors do not lock or unlock.**

**Door Lock Actuator Circuit**

- Refer to Inspection Procedure C-1 (P.54B-40).

**CIRCUIT OPERATION**

- The ETACS-ECU operates the door lock actuators through its dedicated relay (integrated in the ETACS-ECU).
- The ETACS-ECU drives the relay to lock or unlock the door if the requirements are satisfied.

**TECHNICAL DESCRIPTION (COMMENT)**

The door lock actuator, or the harness wire between ETACS-ECU and the door lock actuator may be defective.

**TROUBLESHOOTING HINTS**

- Malfunction of the driver's, front passenger's or rear door lock actuator
- Malfunction of the ETACS-ECU
- Damaged harness wires or connectors

**DIAGNOSIS**

**Required Special Tool:**

- MB991223: Test Harness Set

**STEP 1. Check the location of malfunction.**

**Q: Which door lock does not function?**

**Driver's door :** Go to Step 2.

**Front passenger's door :** Go to Step 5.

**Rear door (LH) :** Go to Step 8.

**Rear door (RH) :** Go to Step 11.

**STEP 2. Check the driver's door lock actuator operation.**

Remove the driver's door lock actuator to check. (Refer to GROUP 42, Door – Door Handle and Latch P.42-58.)

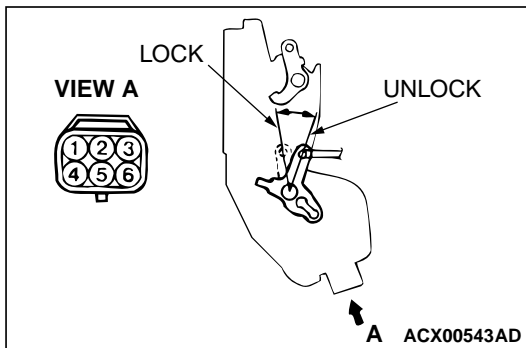

ROD POSITION	BATTERY CONNECTION	ROD OPERATION
LOCK	4 – Battery (+) terminal, 6 – Battery (-) terminal	LOCK position → UNLOCK position
UNLOCK	4 – Battery (-) terminal, 6 – Battery (+) terminal	UNLOCK position → LOCK position

**Q: Is the driver's door lock actuator in good condition?**

**YES :** Go to Step 3.

**NO :** Replace the driver's door lock actuator. All doors should be locked or unlocked.

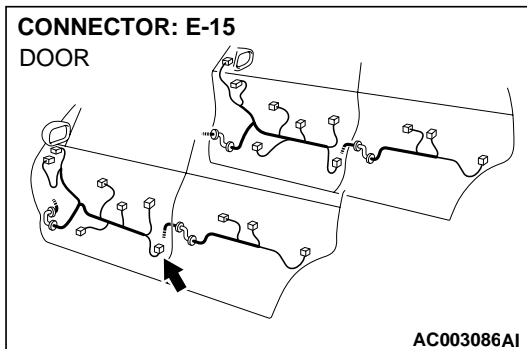
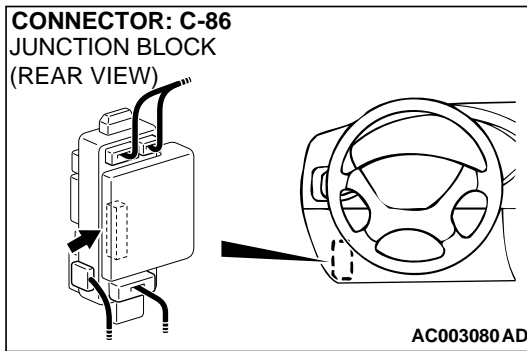

**STEP 3. Check the ETACS-ECU connector C-86 and driver's door lock actuator connector E-15 for damage.**  
**Q: Are ETACS-ECU connector C-86 and driver's door lock actuator connector E-15 in good condition?**

**YES :** Go to Step 4.

**NO :** Repair or replace them. Refer to GROUP 00E, Harness Connector Inspection [P.00E-2](#) . All doors should be locked or unlocked.

**STEP 4. Check the harness wires between ETACS-ECU connector C-86 and driver's door lock actuator connector E-15.**

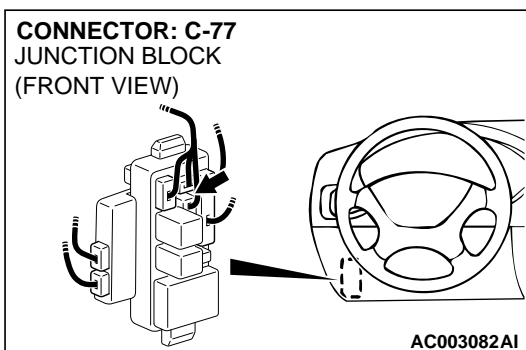
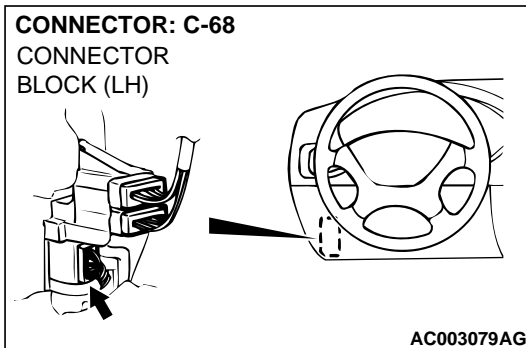
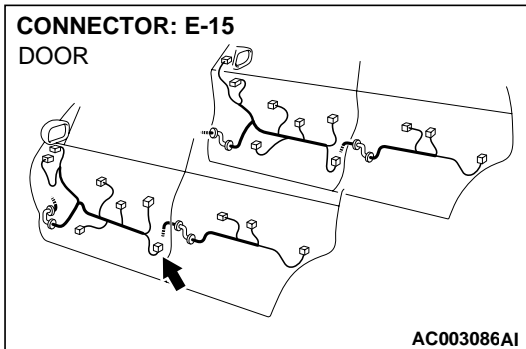
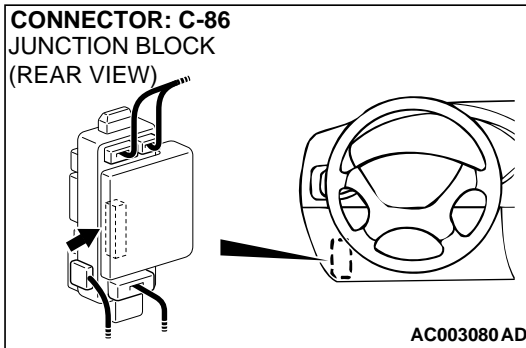

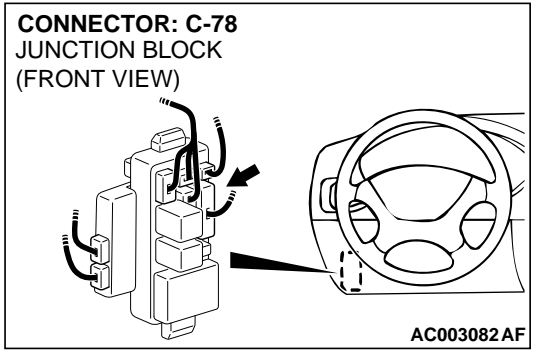

*NOTE: After checking junction block connectors C-77 and C-78 and intermediate connector C-68, check the wires. If junction block connectors C-77 and C-78 and intermediate connector C-68 are damaged, repair or replace them. Refer to GROUP 00E, Harness Connector Inspection P.00E-2 .*

**Q: Are the harness wires between ETACS-ECU connector C-86 and driver's door lock actuator connector E-15 in good condition?**

**YES :** Replace the ETACS-ECU. All doors should be locked or unlocked.

**NO :** Repair them. All doors should be locked or unlocked.

**STEP 5. Check the front passenger's door lock actuator operation.**

Remove the front passenger's door lock actuator to check.  
(Refer to GROUP 42, Door – Door Handle and Latch P.42-58.)

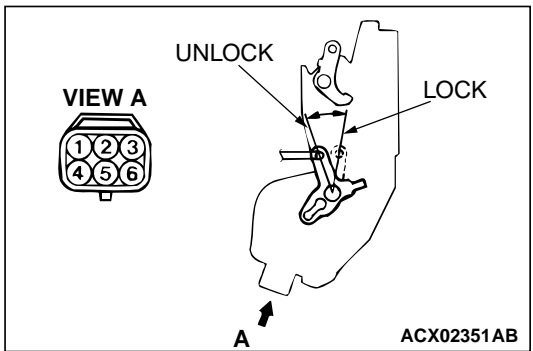

ROD POSITION	BATTERY CONNECTION	ROD OPERATION
LOCK	4 – Battery (–) terminal, 6 – Battery (+) terminal	LOCK position → UNLOCK position
UNLOCK	4 – Battery (+) terminal, 6 – Battery (–) terminal	UNLOCK position → LOCK position

**Q: Is the front passenger's door lock actuator in good condition?**

**YES :** Go to Step 6.

**NO :** Replace the front passenger's door lock actuator. All doors should be locked or unlocked.



**STEP 6.** Check the ETACS-ECU connector C-86 and front passenger's door lock actuator connector E-07 for damage.

**Q:** Are ETACS-ECU connector C-86 and front passenger's door lock actuator connector E-07 in good condition?

**YES :** Go to Step 7.

**NO :** Repair or replace them. Refer to GROUP 00E, Harness Connector Inspection [P.00E-2](#) . All doors should be locked or unlocked.

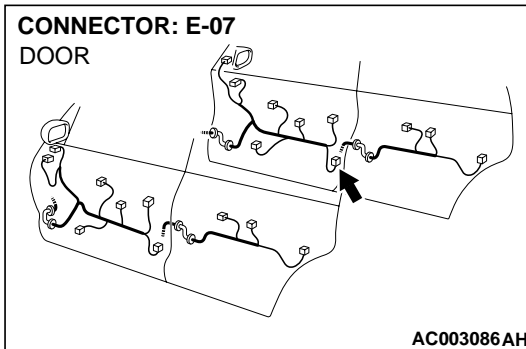
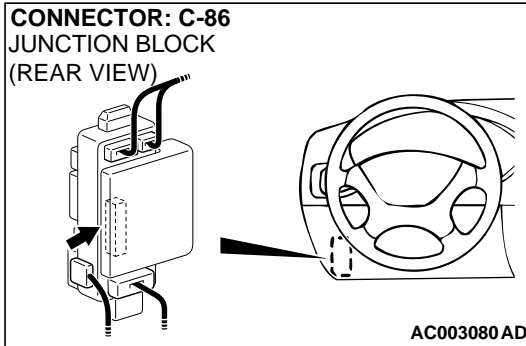

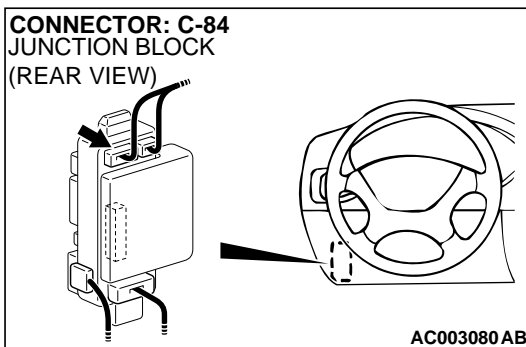
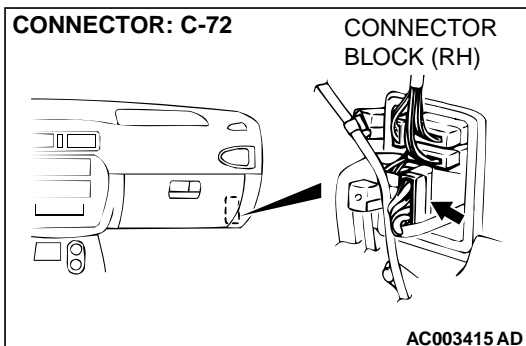
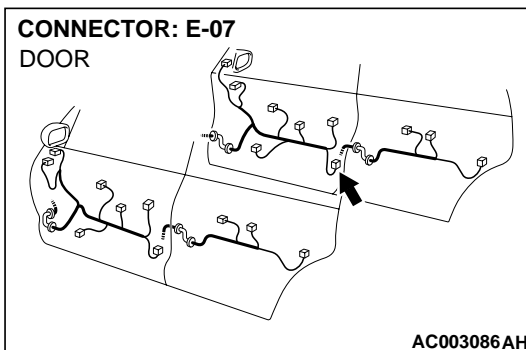
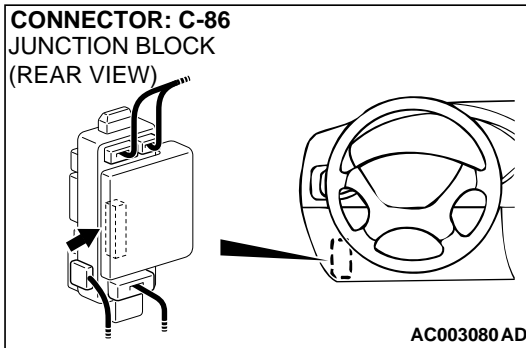

**STEP 7. Check the harness wires between ETACS-ECU connector C-86 and front passenger's door lock actuator connector E-07.**

*NOTE: After checking junction block connector C-78 and intermediate connector C-72, check the wires. If junction block connector C-78 and intermediate connector C-72 are damaged, repair or replace them. Refer to GROUP 00E, Harness Connector Inspection P.00E-2 .*

**Q: Are the harness wires between ETACS-ECU connector C-86 and front passenger's door lock actuator connector E-07 in good condition?**

**YES :** Replace the ETACS-ECU. All doors should be locked or unlocked.

**NO :** Repair them. All doors should be locked or unlocked.

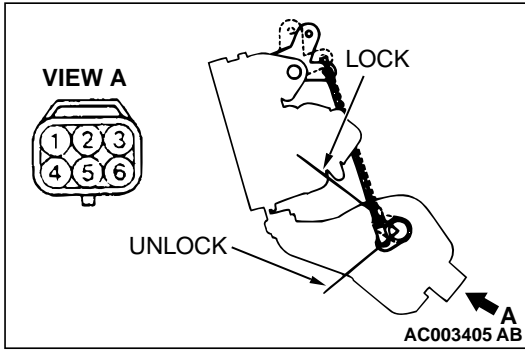

**STEP 8. Check the rear door lock actuator (LH) operation.**  
Remove the rear door lock actuator (LH) to check. (Refer to GROUP 42, Door – Door Handle and Latch P.42-58.)

ROD POSITION	BATTERY CONNECTION	ROD OPERATION
LOCK	4 – Battery (–) terminal, 6 – Battery (+) terminal	LOCK position → UNLOCK position
UNLOCK	4 – Battery (+) terminal, 6 – Battery (–) terminal	UNLOCK position → LOCK position

**Q: Is the rear door lock actuator (LH) in good condition?**

**YES :** Go to Step 9.

**NO :** Replace the rear door lock actuator (LH). All doors should be locked or unlocked.

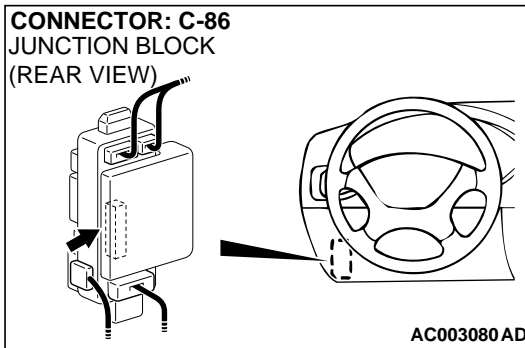

**STEP 9. Check the ETACS-ECU connector C-86 and rear door lock actuator (LH) connector E-11 for damage.**

**Q: Are ETACS-ECU connector C-86 and rear door lock actuator (LH) connector E-11 in good condition?**

**YES :** Go to Step 10.

**NO :** Repair or replace them. Refer to GROUP 00E, Harness Connector Inspection P.00E-2 . All doors should be locked or unlocked.

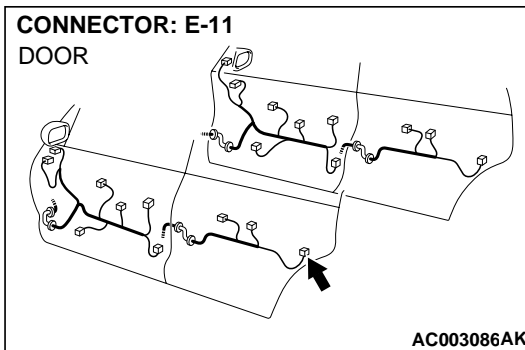

**STEP 10.** Check the harness wires between ETACS-ECU connector C-86 and rear door lock actuator (LH) connector E-11.

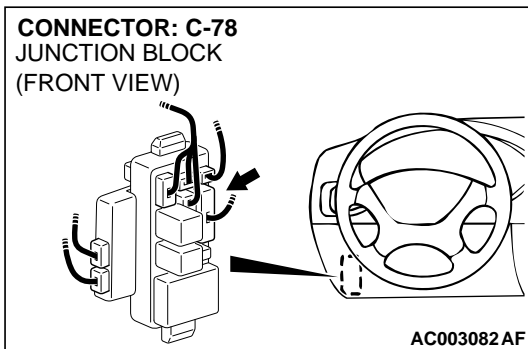
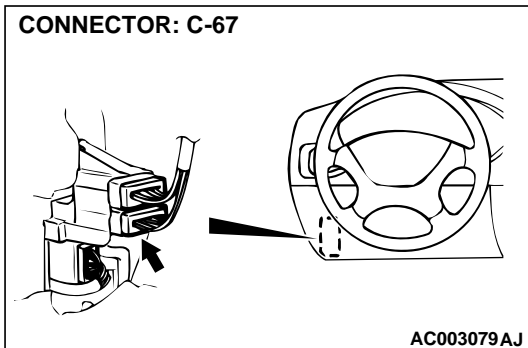
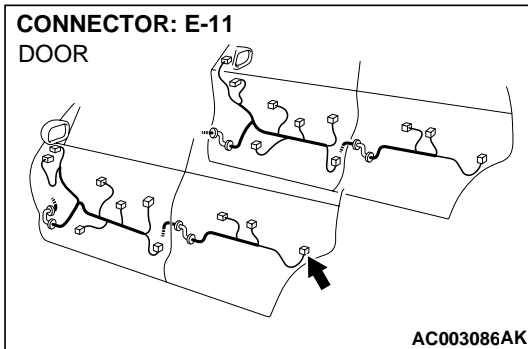
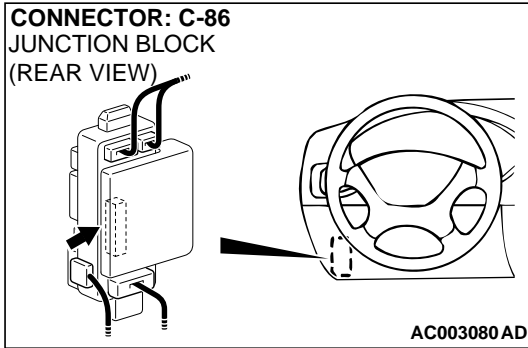

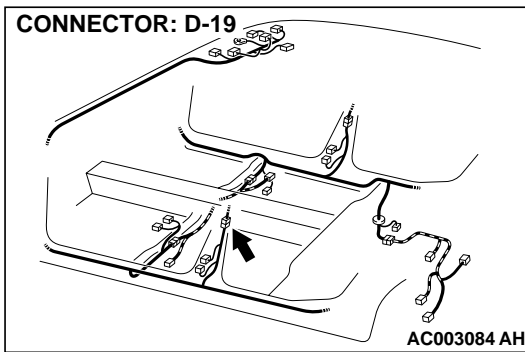
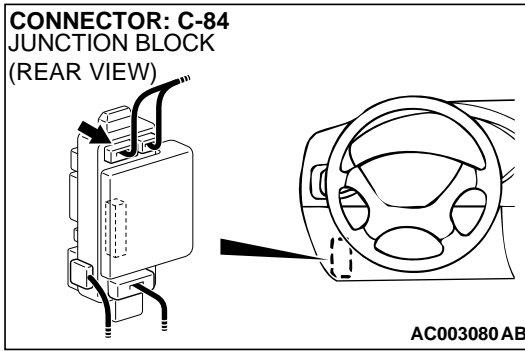

*NOTE: After checking junction block connector C-78 and C-84 and intermediate connector C-67 and D-19, check the wires. If junction block connector C-78 and C-84 and intermediate connector C-67 and D-19 are damaged, repair or replace them. Refer to GROUP 00E, Harness Connector Inspection P.00E-2.*

**Q: Are the harness wires between ETACS-ECU connector C-86 and rear door lock actuator (LH) connector E-11 in good condition?**

**YES :** Replace the ETACS-ECU. All doors should be locked or unlocked.

**NO :** Repair them. All doors should be locked or unlocked.

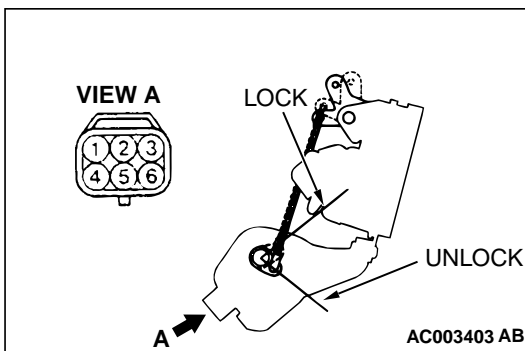

**STEP 11. Check the rear door lock actuator (RH) operation.** Remove the rear door lock actuator (RH) to check. (Refer to GROUP 42, Door – Door Handle and Latch P.42-58.)

ROD POSITION	BATTERY CONNECTION	ROD OPERATION
LOCK	4 – Battery (+) terminal, 6 – Battery (-) terminal	LOCK position → UNLOCK position
UNLOCK	4 – Battery (-) terminal, 6 – Battery (+) terminal	UNLOCK position → LOCK position

**Q: Is the rear door lock actuator (RH) in good condition?**

**YES :** Go to Step 12.

**NO :** Replace the rear door lock actuator (RH). All doors should be locked or unlocked.

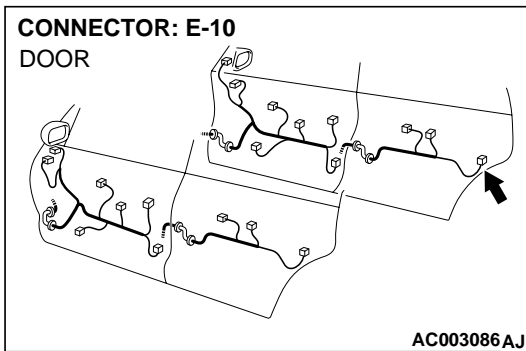
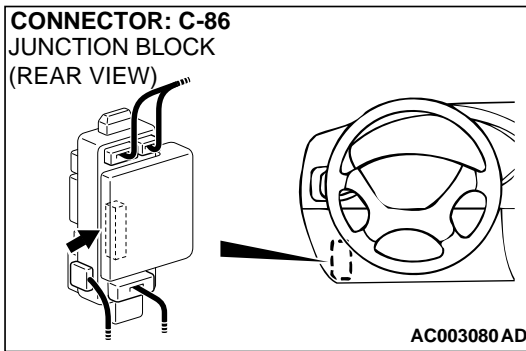

**STEP 12.** Check the ETACS-ECU connector C-86 and rear door lock actuator (RH) connector E-10 for damage.

**Q:** Are ETACS-ECU connector C-86 and rear door lock actuator (RH) connector E-10 in good condition?

**YES :** Go to Step 13.

**NO :** Repair or replace them. Refer to GROUP 00E, Harness Connector Inspection [P.00E-2](#) . All doors should be locked or unlocked.

**STEP 13.** Check the harness wires between ETACS-ECU connector C-86 and rear door lock actuator (RH) connector E-10.

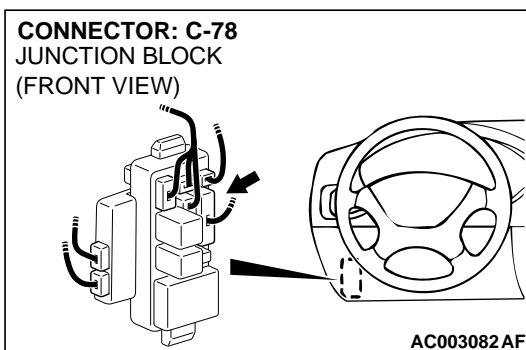
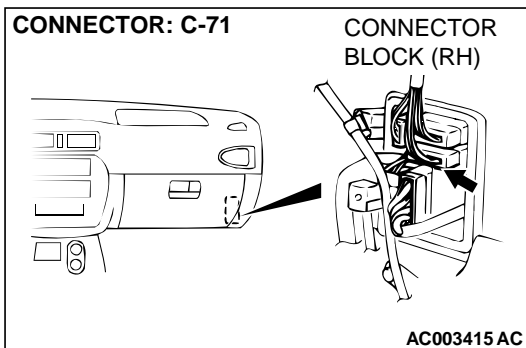
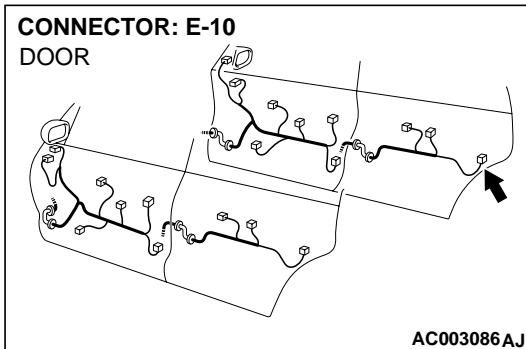
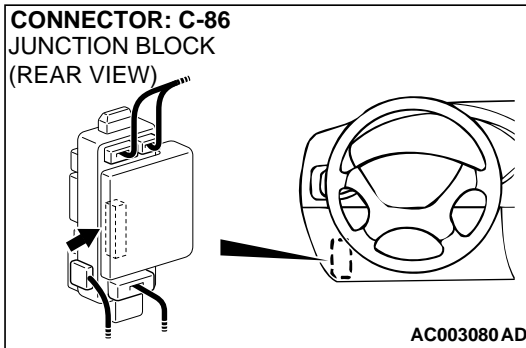

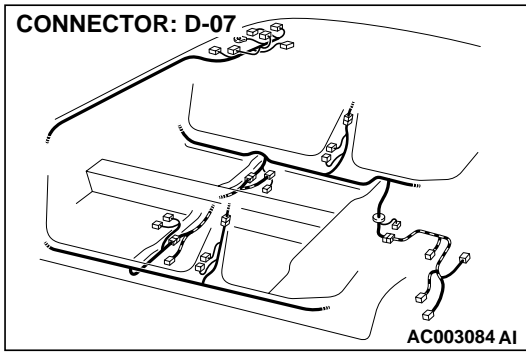

*NOTE: After checking junction block connector C-78 and intermediate connector C-71 and D-07, check the wires. If junction block connector C-78 and intermediate connector C-71 and D-07 are damaged, repair or replace them. Refer to GROUP 00E, Harness Connector Inspection P.00E-2 .*

**Q: Are the harness wires between ETACS-ECU connector C-86 and rear door lock actuator (RH) connector E-10 in good condition?**

**YES :** Replace the ETACS-ECU. All doors should be locked or unlocked.

**NO :** Repair them. All doors should be locked or unlocked.

**Inspection Procedure C-3: Central door locking system: All the doors do not lock or unlock with just the door lock switch operation.**

**TECHNICAL DESCRIPTION (COMMENT)**

The door lock switch (built into the power window switch) or the ETACS-ECU may be defective.

**TROUBLESHOOTING HINTS**

- Malfunction of the power window switch (door lock switch)
- Damaged harness wires or connectors

**DIAGNOSIS**

**Required Special Tools:**

- MB991502: Scan Tool (MUT-II)
- MB991529: Diagnostic Trouble Code Check Harness

**STEP 1. Check method of the input signal**

**Q: Which is to be used, the scan tool or the voltmeter to check the input signal?**

**Scan tool MB991502 :** Go to Step 2.

**Voltmeter :** Go to Step 3.

**STEP 2. Check the input signal (by using scan tool MB991502).**

Check the input signals from the defective door lock switch.

**⚠ CAUTION**

**To prevent damage to scan tool MB991502, always turn the ignition switch to the "LOCK" (OFF) position before connecting or disconnecting scan tool MB991502.**

- (1) Connect scan tool MB991502 to the data link connector.
- (2) Check that the tone alarm of scan tool MB991502 sounds when the input signal enters.

**Q: Does the tone alarm of scan tool MB991502 sound when the input signal enters?**

**YES :** Replace the ETACS-ECU. All doors should be locked or unlocked by using the door lock switch.

**NO :** Check the defective door lock switch input circuit. Refer to Inspection Procedure N-10 (P.54B-237).

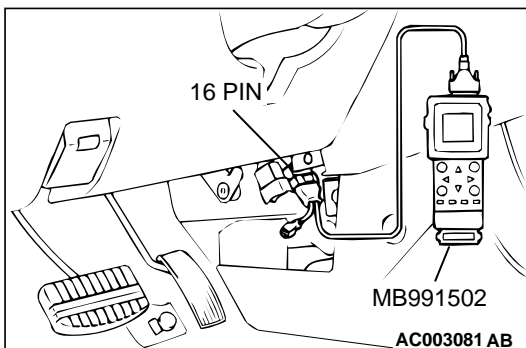



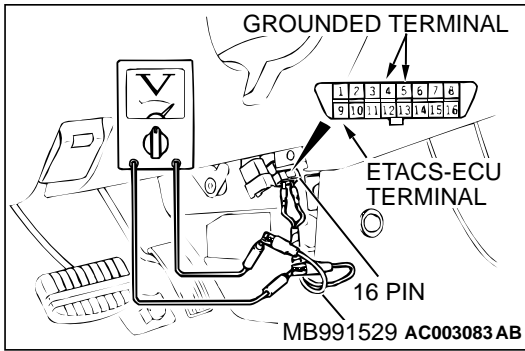

**STEP 3. Check the input signal (by using a voltmeter).**

Check the input signals from the defective door lock switch.

- (1) Use special tool MB991529 to connect a voltmeter between ground terminal 4 or 5 and ETACS-ECU terminal 9 of the data link connector.
- (2) Check that the voltmeter indicator deflects once when the input signal enters.

**Q: Does the voltmeter indicator deflect?**

**YES :** Replace the ETACS-ECU. All doors should be locked or unlocked by using the door lock switch.

**NO :** Check the defective door lock switch input circuit. Refer to Inspection Procedure N-10 (P.54B-237).

**Inspection Procedure C-4: Central door locking system: All the doors do not lock or unlock with just the door lock key cylinder key operation.**

**TECHNICAL DESCRIPTION (COMMENT).**

The door lock key cylinder switch or the ETACS-ECU may be defective.

**TROUBLESHOOTING HINTS**

- Malfunction of the door lock key cylinder switch
- Damaged harness wires or connectors

**DIAGNOSIS**

**Required Special Tools:**

- MB991502: Scan Tool (MUT-II)
- MB991529: Diagnostic Trouble Code Check Harness

**STEP 1. Check method of the input signal**

**Q: Which is to be used, the scan tool or the voltmeter to check the input signal?**

**Scan tool MB991502 :** Go to Step 2.

**Voltmeter :** Go to Step 3.

**STEP 2. Check the input signal (by using scan tool MB991502).**

Check the input signal from the defective door lock key cylinder switch.

**CAUTION**

To prevent damage to scan tool MB991502, always turn the ignition switch to the "LOCK" (OFF) position before connecting or disconnecting scan tool MB991502.

- (1) Connect scan tool MB991502 to the data link connector.
- (2) Check that the tone alarm of scan tool MB991502 sounds when the input signal enters.

**Q: Does the tone alarm of scan tool MB991502 sound when the input signal enters?**

**YES :** Replace the ETACS-ECU. All doors should be locked or unlocked by using the door lock key cylinder switch.

**NO :** Check the door lock key cylinder switch input circuit. Refer to Inspection Procedure N-8 (P.54B-212).

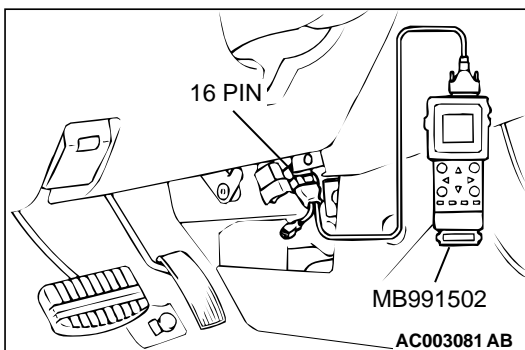

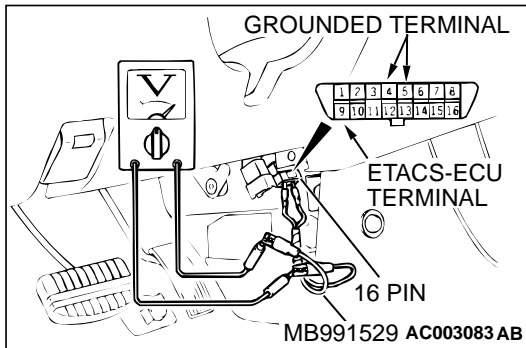
**STEP 3. Check the input signal (by using a voltmeter).**

Check the input signal from the defective door lock key cylinder switch.

- (1) Use special tool MB991529 to connect a voltmeter between ground terminal 4 or 5 and ETACS-ECU terminal 9 of the data link connector.
- (2) Check that the voltmeter indicator deflects once when the input signal enters.

**Q: Does the voltmeter indicator deflect?**

**YES :** Replace the ETACS-ECU. All doors should be locked or unlocked by using the door lock key cylinder switch.

**NO :** Check the door lock key cylinder switch input circuit. Refer to Inspection Procedure N-8 (P.54B-212).

**Inspection Procedure C-5: Central door locking system: All the doors do not lock with just the driver's inside lock knob lock operation.**

**TECHNICAL DESCRIPTION.**

The driver's door lock actuator switch or the ETACS-ECU may be defective.

**TROUBLESHOOTING HINTS**

- Malfunction of the driver's door lock actuator switch
- Damaged harness wires or connectors

**DIAGNOSIS****Required Special Tools:**

- MB991502: Scan Tool (MUT-II)
- MB991529: Diagnostic Trouble Code Check Harness

**STEP 1. Check method of the input signal**

**Q: Which is to be used, the scan tool or the voltmeter to check the input signal?**

**Scan tool MB991502 :** Go to Step 2.

**Voltmeter :** Go to Step 3.

**STEP 2. Check the input signal (by using scan tool MB991502).**

Check the input signal from the driver's door lock actuator switch.

**CAUTION**

To prevent damage to scan tool MB991502, always turn the ignition switch to the "LOCK" (OFF) position before connecting or disconnecting scan tool MB991502.

- (1) Connect scan tool MB991502 to the data link connector.
- (2) Check that the tone alarm of scan tool MB991502 sounds when the input signal enters.

**Q: Does the tone alarm of scan tool MB991502 sound when the input signal enters?**

**YES :** Replace the ETACS-ECU. All doors should be locked by using the driver's inside lock knob.

**NO :** Check the driver's door lock actuator switch input circuit. Refer to Inspection Procedure N-09 (P.54B-220).

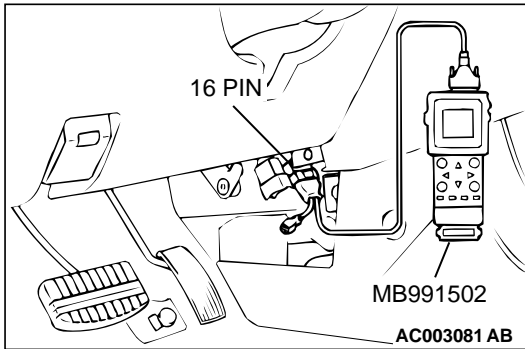

**STEP 3. Check the input signal (by using a voltmeter).**

Check the input signal from the driver's door lock actuator switch.

- (1) Use special tool MB991529 to connect a voltmeter between ground terminal 4 or 5 and ETACS-ECU terminal 9 of the data link connector.
- (2) Check that the voltmeter indicator deflects once when the input signal enters.

**Q: Does the voltmeter indicator deflect?**

**YES :** Replace the ETACS-ECU. All doors should be locked by using the driver's inside lock knob.

**NO :** Check the driver's door lock actuator switch input circuit. Refer to Inspection Procedure N-09 (P.54B-220).

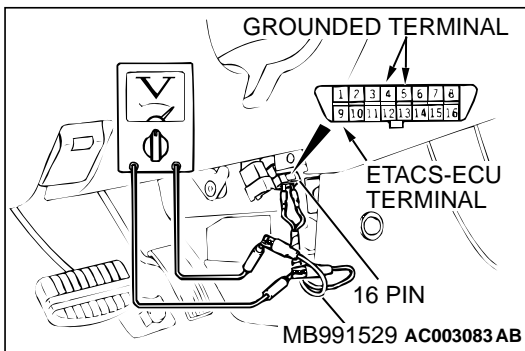

**Inspection Procedure C-6: Central door locking system: Forgotten key prevention function does not operate.**

**TECHNICAL DESCRIPTION (COMMENT).**

The ETACS-ECU operates the forgotten key prevention function, based on the input signals from the following switches:

- Key reminder switch
- Driver's or passenger's door switch
- Driver's or passenger's door lock actuator switch

If the function does not work normally, a defect on the relevant circuit or the ETACS-ECU may be suspected.

**TROUBLESHOOTING HINTS**

- Malfunction of the key reminder switch
- Malfunction of the driver's or front passenger's door switch
- Malfunction of the driver's or front passenger's door lock actuator switch
- Malfunction of the ETACS-ECU
- Damaged harness wires or connectors

**DIAGNOSIS****Required Special Tools:**

- MB991502: Scan Tool (MUT-II)
- MB991529: Diagnostic Trouble Code Check Harness

**STEP 1. Check method of the input signal**

**Q: Which is to be used, the scan tool or the voltmeter to check the input signal?**

**Scan tool MB991502 :** Go to Step 2.

**Voltmeter :** Go to Step 3.

**STEP 2. Check the input signal (by using scan tool MB991502).**

Check the input signals from the following switches:

- Key reminder switch
- Driver's and front passenger's door switch
- Driver's and front passenger's door lock actuator switch

**⚠ CAUTION**

**To prevent damage to scan tool MB991502, always turn the ignition switch to the "LOCK" (OFF) position before connecting or disconnecting scan tool MB991502.**

- (1) Connect scan tool MB991502 to the data link connector.
- (2) Check that the tone alarm of scan tool MB991502 sounds when the input signal enters.

**Q: Does the tone alarm of scan tool MB991502 sound when the input signal enters?**

**YES :** Replace the ETACS-ECU. The forgotten key prevention function should work normally.

**NO :** Check the relevant input circuit. Refer to [P.54B-9](#).

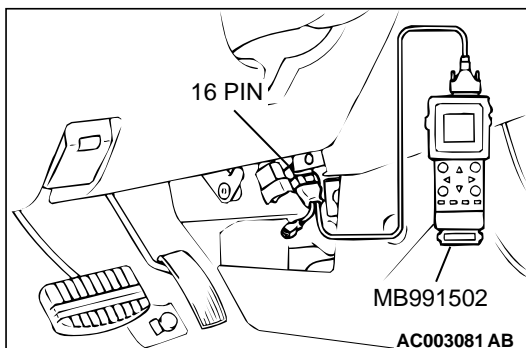
**STEP 3. Check the input signal (by using scan tool MB991502).**

Check the input signals from the following switches:

- Key reminder switch
- Driver's and front passenger's door switch
- Driver's and front passenger's door lock actuator switch

- (1) Use special tool MB991529 to connect a voltmeter between ground terminal 4 or 5 and ETACS-ECU terminal 9 of the data link connector.
- (2) Check that the voltmeter indicator deflects once when the input signal enters.

**Q: Does the voltmeter indicator deflect?**

**YES :** Replace the ETACS-ECU. The forgotten key prevention function should work normally.

**NO :** Check the relevant input circuit. Refer to [P.54B-9](#).

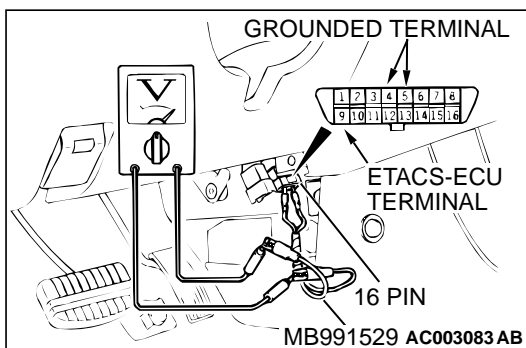

**Inspection Procedure D-1: Power window relay: Power windows do not work at all.**

**Power Window Relay Circuit**

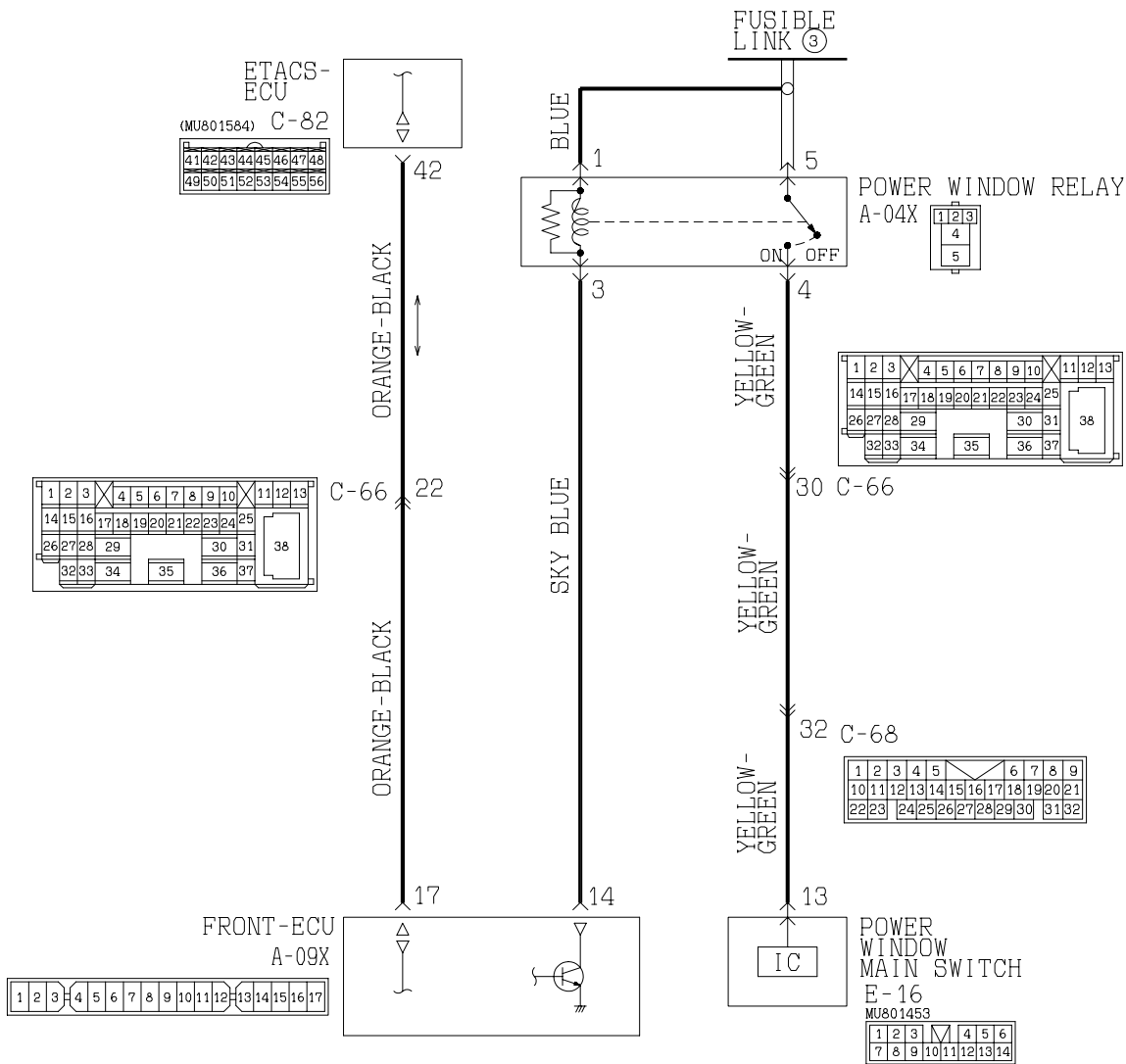

W1S09M05AA

AC004204

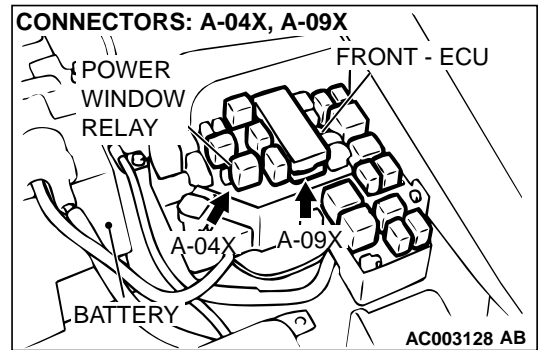
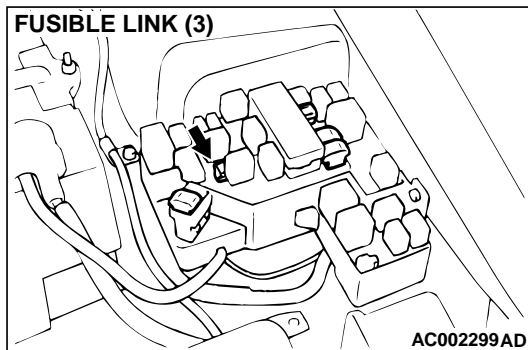

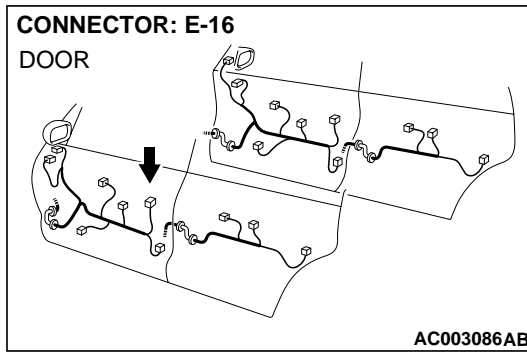
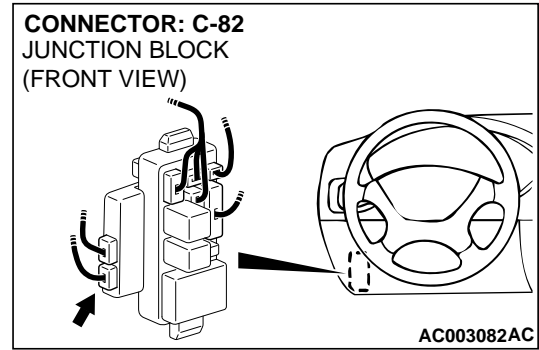
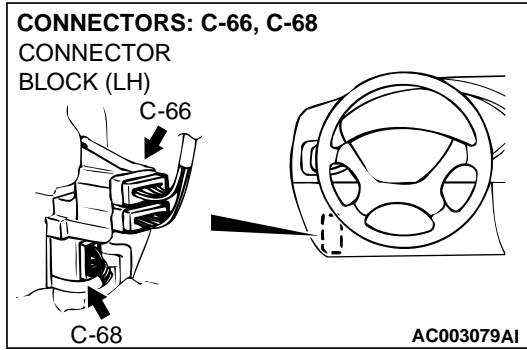

**CIRCUIT OPERATION**

- The power window relay is controlled by the front-ECU and the ETACS-ECU
- The front-ECU operates the power window relay if the front-ECU receives request signal from the ETACS-ECU, or ignition switch (IG1) signal from the front-ECU itself.

**TECHNICAL DESCRIPTION (COMMENT)**

The power window relay or the front-ECU may be defective.

**TROUBLESHOOTING HINTS**

- Malfunction of the power window relay
- Malfunction of the front-ECU
- Damaged harness wires or connectors

**DIAGNOSIS**

**Required Special Tool:**

- MB991223: Test Harness Set

**STEP 1. Check the power window relay.**

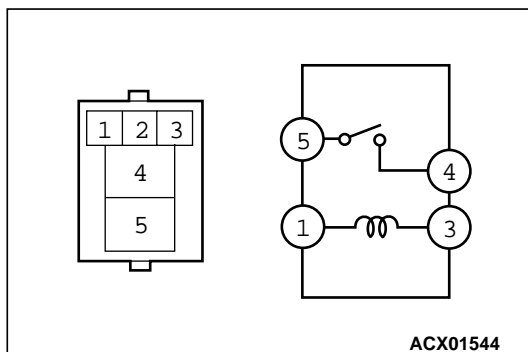

BATTERY VOLTAGE	TESTER CONNECTION	SPECIFIED CONDITION
Not applied	1 – 3	Continuity
1 – Battery (+) terminal, 3 – Battery (-) terminal	4 – 5	Continuity

**Q: Is the power window relay in good condition?**

**YES :** Go to Step 2.

**NO :** Replace it. The power windows should work normally.

**STEP 2. Check the power window relay power supply circuit at the power window relay connector A-04X.**

- (1) Disconnect the power window relay connector A-04X and measure at the relay box side.
- (2) Measure the voltages between terminal 1, 5 and ground.

**Q: Are the voltages approximately 12 volts (battery positive voltage)?**

**YES :** Go to Step 5.

**NO :** Go to Step 3.

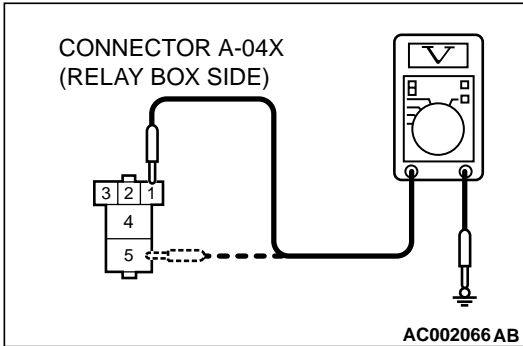

**STEP 3. Check the power window connector A-04X for damage.**

**Q: Is power window connector A-04X in good condition?**

**YES :** Go to Step 4.

**NO :** Repair or replace it. Refer to GROUP 00E, Harness Connector Inspection [P.00E-2](#) . The power windows should work normally.

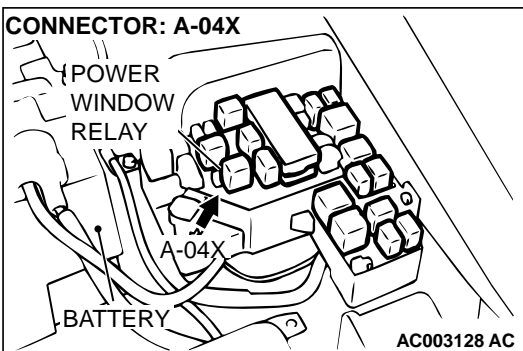

**STEP 4. Check the harness wire between power window relay connector A-04X and fusible link (3).**

**Q: Is the harness wire between power window relay connector A-04X and fusible link (3) in good condition?**

**YES :** There is no action to be taken.

**NO :** Repair it. The power windows should work normally.

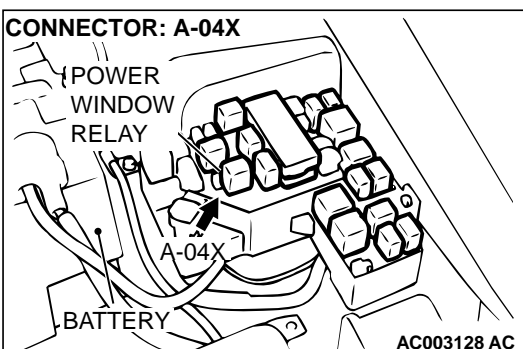
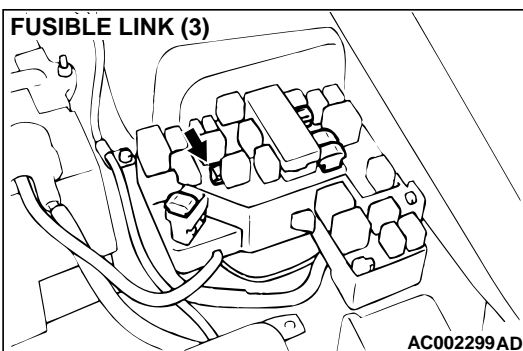

**STEP 5. Check the power window main switch ground circuit at the power window main switch connector E-16.**

- (1) Disconnect the power window main switch connector E-16 and measure at the harness side.
- (2) Measure the resistance between terminal 12 and ground.

**Q: Is the resistance less than 2 ohm?**

- YES :** Go to Step 8.
- NO :** Go to Step 6.

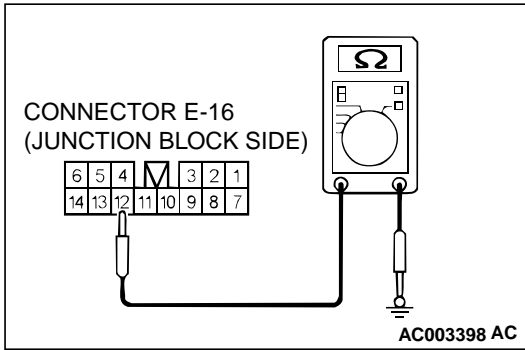

**STEP 6. Check power window main switch connector E-16 for damage.**

**Q: Is power window main switch connector E-16 in good condition?**

- YES :** Go to Step 7.
- NO :** Repair or replace it. Refer to GROUP 00E, Harness Connector Inspection [P.00E-2](#) . The power windows should work normally.

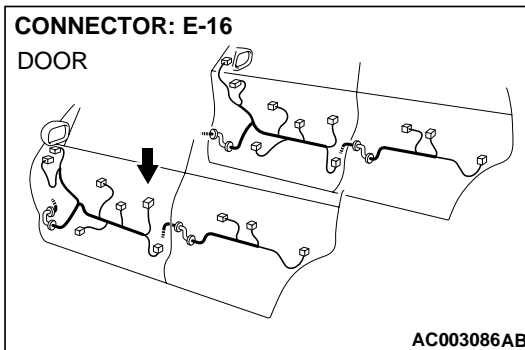

**STEP 7. Check the harness wires between power window main switch connector E-16 and ground.**

*NOTE: After checking intermediate connector C-68, check the wires. If intermediate connector C-68 is damaged, repair or replace it. Refer to GROUP 00E, Harness Connector Inspection [P.00E-2](#) .*

**Q: Are the harness wires between power window main switch connector E-16 and ground in good condition?**

- YES :** There is no action to be taken.
- NO :** Repair them. The power windows should work normally.

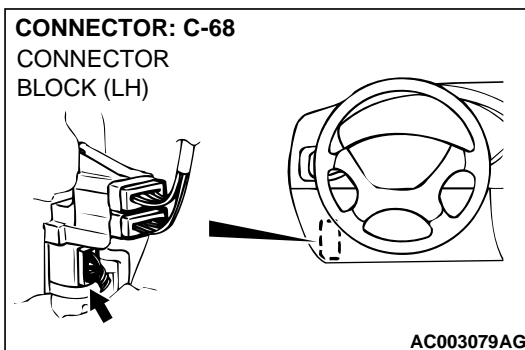
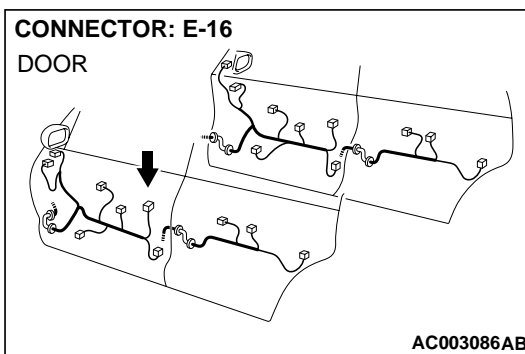



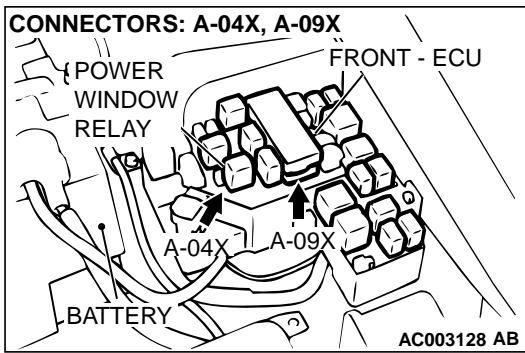

**STEP 8. Check the power window relay connector A-04X and front-ECU connector A-09X for damage.**

**Q: Are power window relay connector A-04X and front-ECU connector A-09X in good condition?**

**YES :** Go to Step 9.

**NO :** Repair or replace them. Refer to GROUP 00E, Harness Connector Inspection [P.00E-2](#) . The power windows should work normally.

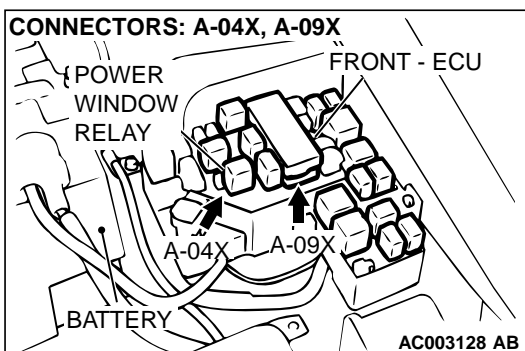

**STEP 9. Check the harness wire between power window relay connector A-04X and front-ECU connector A-09X.**

**Q: Is the harness wire between power window relay connector A-04X and front-ECU connector A-09X in good condition?**

**YES :** Go to Step 10.

**NO :** Repair it. The power windows should work normally.

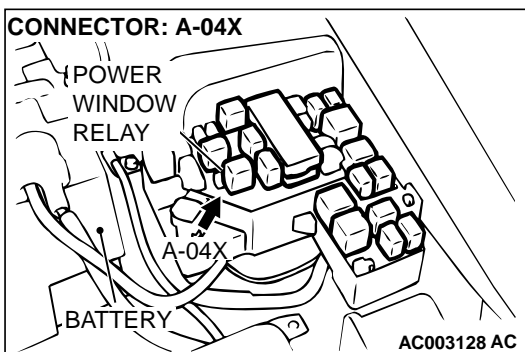

**STEP 10. Check the power window relay connector A-04X and power window main switch connector E-16 for damage.**

**Q: Are power window relay connector A-04X and power window main switch connector E-16 in good condition?**

**YES :** Go to Step 11.

**NO :** Repair or replace them. Refer to GROUP 00E, Harness Connector Inspection [P.00E-2](#) . The power windows should work normally.

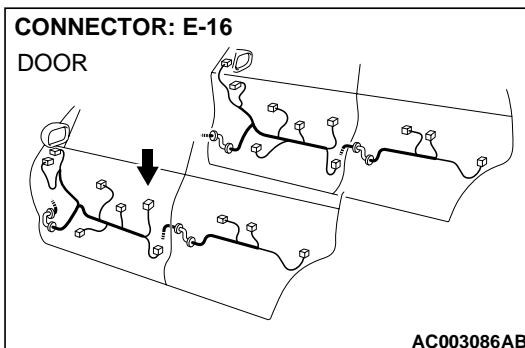

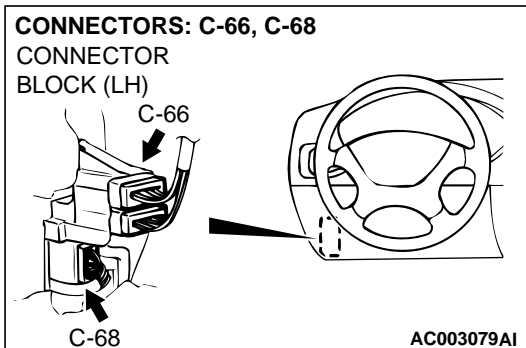
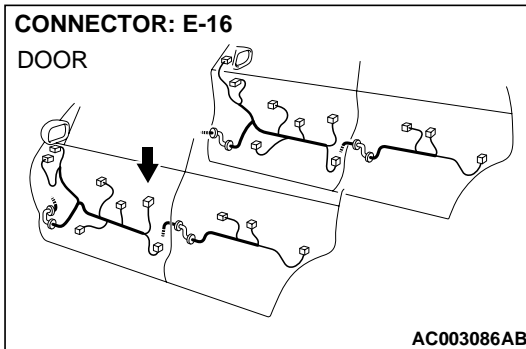
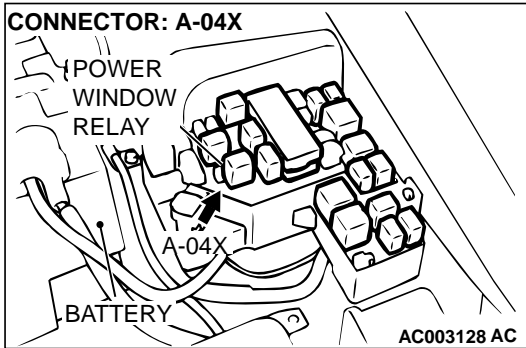

**STEP 11. Check the harness wires between power window relay connector A-04X and power window main switch connector E-16.**

*NOTE: After checking intermediate connectors C-66 and C-68, check the wires. If intermediate connectors C-66 and C-68 are damaged, repair or replace them. Refer to GROUP 00E, Harness Connector Inspection P.00E-2 .*

**Q: Are the harness wires between power window relay connector A-04X and power window main switch connector E-16 in good condition?**

**YES :** Replace the ETACS-ECU. The power windows should work normally.

**NO :** Repair them. The power windows should work normally.

**Inspection Procedure D-2: Power window relay: Power window timer function does not work normally.**

**TECHNICAL DESCRIPTION (COMMENT)**

The ETACS-ECU operates the power window timer function, based on input signals from the following switches:

- Ignition switch (IG1)
- Driver's or passenger's door switch

If the power window timer function do not work normally, the input signal circuit, the ETACS-ECU or front-ECU may be defective.

**TROUBLESHOOTING HINTS**

- Malfunction of the driver's or front passenger's door switch
- Malfunction of the ETACS-ECU
- Malfunction of the front-ECU
- Damaged harness wires or connectors

**DIAGNOSIS**

**Required Special Tools:**

- MB991502: Scan Tool (MUT-II)
- MB991529: Diagnostic Trouble Code Check Harness

**STEP 1. Check method of the input signal**

**Q: Which is to be used, the scan tool or the voltmeter to check the input signal?**

**Scan tool MB991502 :** Go to Step 2.

**Voltmeter :** Go to Step 3.

**STEP 2. Check the input signal (by using scan tool MB991502).**

Check the input signals from the following switches:

- Ignition switch (IG1)
- Driver's and front passenger's door switch

**⚠ CAUTION**

**To prevent damage to scan tool MB991502, always turn the ignition switch to the "LOCK" (OFF) position before connecting or disconnecting scan tool MB991502.**

- (1) Connect scan tool MB991502 to the data link connector.
- (2) Check that the tone alarm of scan tool MB991502 sounds when the input signal enters.

**Q: Does the tone alarm of scan tool MB991502 sound when the input signal enters?**

**YES :** Go to Step 4.

**NO :** Check the relevant input circuit. Refer to [P.54B-9](#).

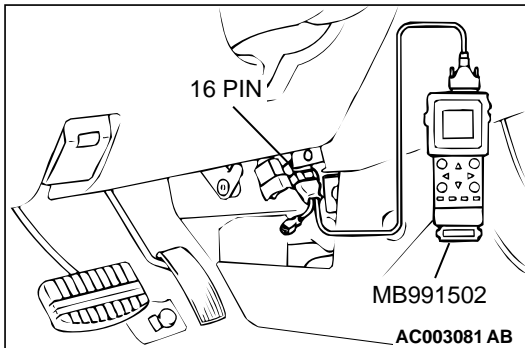

**STEP 3. Check the input signal (by using a voltmeter).**

Check the input signals from the following switches:

- Ignition switch (IG1)
- Driver's and front passenger's door switch

- (1) Use special tool MB991529 to connect a voltmeter between ground terminal 4 or 5 and ETACS-ECU terminal 9 of the data link connector.
- (2) Check that the voltmeter indicator deflects once when the input signal enters.

**Q: Does the voltmeter indicator deflect?**

**YES :** Go to Step 4.

**NO :** Check the relevant input circuit. Refer to [P.54B-9](#).

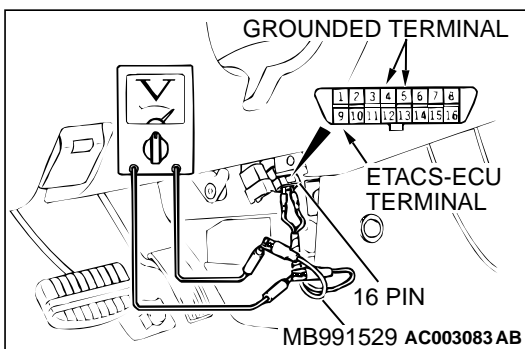

**STEP 4. Replacement of ECU.**

- (1) Replace the front-ECU.
- (2) The power window timer function should work normally.

**Q: Is the power window timer function working normally?**

- YES :** Replace the ETACS-ECU. The power window timer function should work normally.
- NO :** There is no action to taken.

**Inspection Procedure E-1: Keyless entry system: Keyless entry system does not operate.**

**Receiver and Transmitter Communication System**

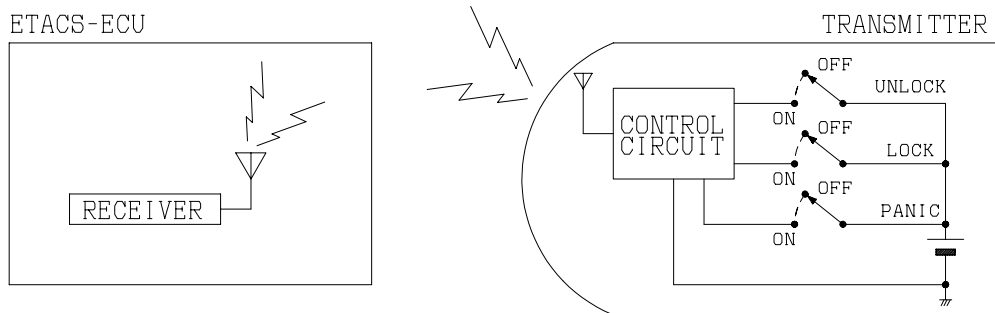

W9S02M05A  
AC004205

**CIRCUIT OPERATION**

Receiver within the ETACS-ECU receives the lock/unlock signal from the transmitter.

**TROUBLESHOOTING HINTS**

- Malfunction of the ETACS-ECU
- Malfunction of the transmitter

**TECHNICAL DESCRIPTION (COMMENT)**

The cause may be a malfunction of the receiver and transmitter communication system.

**DIAGNOSIS**

**Required Special Tools:**

- MB991502: Scan Tool (MUT-II)
- MB991529: Diagnostic Trouble Code Check Harness

**STEP 1. Check the central door locking system operation.**

**Q: Does the central door locking system work normally?**

- YES :** Go to Step 2 <when using scan tool MB991502> or 3 <when using a voltmeter>.
- NO :** Solve the problem first. Refer to [P.54B-40](#).

**STEP 2. Check the input signal (by using scan tool MB991502).**

Check the input signals from the transmitter switches.

**⚠ CAUTION**

To prevent damage to scan tool MB991502, always turn the ignition switch to the "LOCK" (OFF) position before connecting or disconnecting scan tool MB991502.

- (1) Connect scan tool MB991502 to the data link connector.
- (2) Check that the tone alarm of scan tool MB991502 sounds when the input signal enters.

**Q: Does the tone alarm of scan tool MB991502 sound when the input signal enters?**

- YES :** Replace the ETACS-ECU. All the doors should be locked or unlocked by using the transmitter.
- NO :** Check the transmitter input circuit. Refer to Inspection Procedure N-17 (P.54B-265 ).

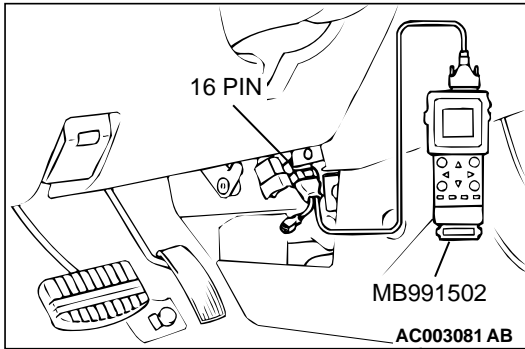

**STEP 3. Check the input signal (by using a voltmeter).**

Check the input signals from the transmitter switches.

- (1) Use special tool MB991529 to connect a voltmeter between ground terminal 4 or 5 and ETACS-ECU terminal 9 of the data link connector.
- (2) Check that the voltmeter indicator deflects once when the input signal enters.

**Q: Does the voltmeter indicator deflect?**

- YES :** Replace the ETACS-ECU. All the doors should be locked or unlocked by using the transmitter.
- NO :** Check the transmitter input circuit. Refer to Inspection Procedure N-17 (P.54B-265 ).

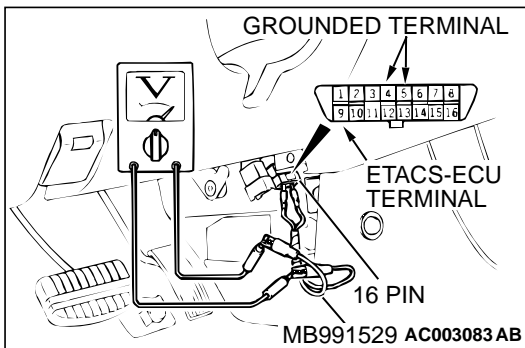

Inspection Procedure E-2: Keyless entry system: The dome light, the hazard warning lights and the horn do not operate through the answerback function.

Horn Circuit <2000 models without theft-alarm system>

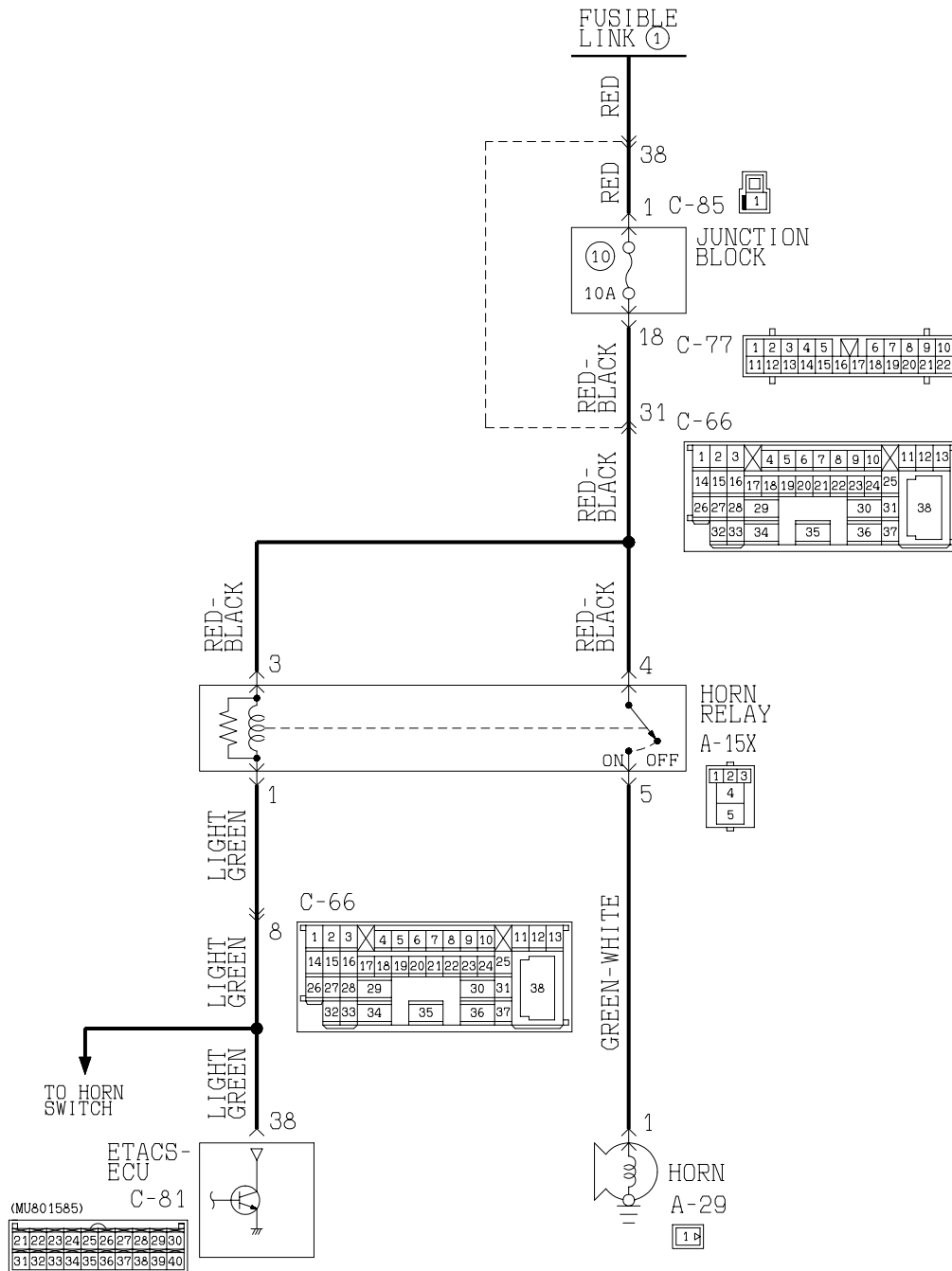

W1S09M07AA

AC004206

TSB Revision

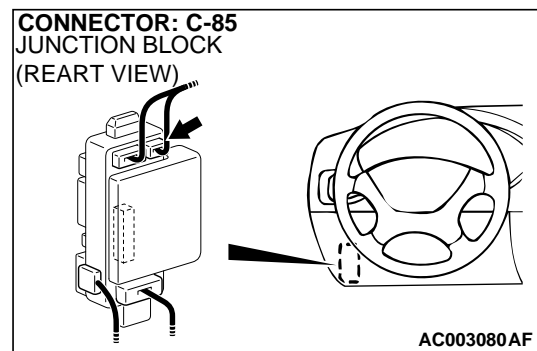
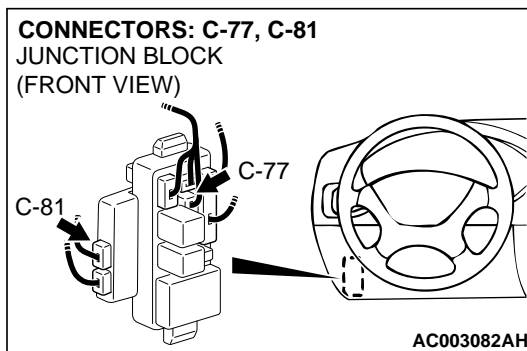
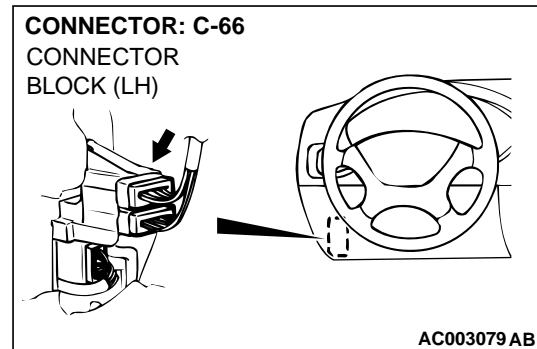
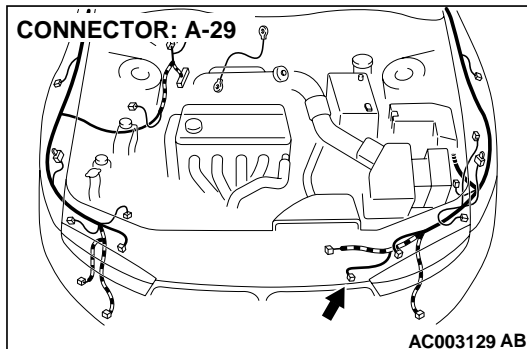
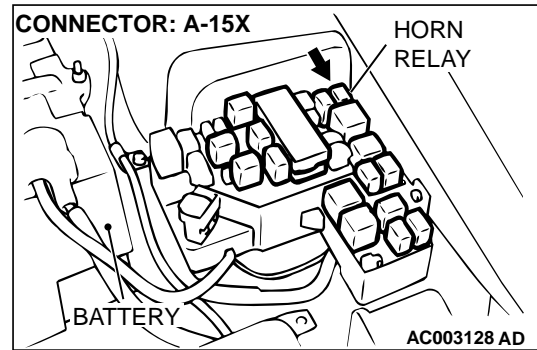
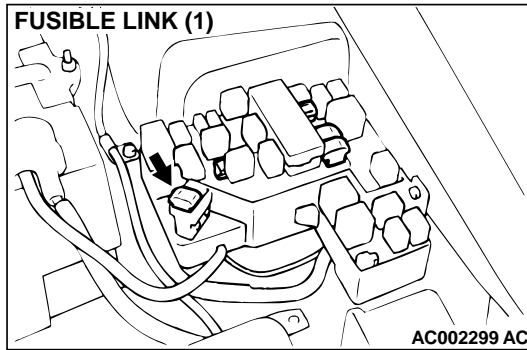

**CIRCUIT OPERATION.**

The turn-signal light and the horn answerback functions can be selected by the driver's desire (can be deactivated). However, the interior lights answerback function can not be deactivated. If all of these devices do not operate through the answerback function, the ETACS-ECU may be defective.

**TROUBLESHOOTING HINTS**

- Malfunction of the turn-signal light
- Malfunction of the horn
- Malfunction of the horn relay
- Malfunction of the dome light
- Malfunction of the ETACS-ECU
- Damaged harness wires or connectors

**DIAGNOSIS**

**Required Special Tools:**

- MB991223: Test Harness Set
- MB991502: Scan Tool (MUT-II)
- MB991529: Diagnostic Trouble Code Check Harness

**STEP 1. Check the answerback set condition.**

Activate the answerback functions. (Refer to GROUP 42, Keyless Entry System – On-vehicle Service – Enabling/disabling the Answerback Function [P.42-68](#).)

**Q: Does the answerback function work normally?**

**YES** : There is no action to be taken.

**NO** : Go to Step 2.

---

**STEP 2. Check trouble symptom.****Q: Which component(s) does not operate through the answerback?**

**Only the dome light** : Go to Step 3.

**Only the hazard warning lights** : Go to Step 4.

**Only the horn <Vehicles with theft-alarm system>** : Go to Step 5.

**Only the horn <Vehicles without theft-alarm system>** : Go to Step 6.

**None of the dome light, the turn-signal lights, and the horn** : Replace the ETACS-ECU. The answerback function should work normally.

---

**STEP 3. Check the dome light dimming function.****Q: Does the dome light dimming function work normally?**

**YES** : Replace the ETACS-ECU. The answerback function should work normally.

**NO** : Solve the problem first. Refer to Inspection Procedure L-1 ([P.54B-158](#) ).

---

**STEP 4. Check the hazard warning light operation.****Q: Do the hazard warning lights operate normally?**

**YES** : Replace the ETACS-ECU. The answerback function should work normally.

**NO** : Solve the problem first. Refer to Inspection Procedure J-2 ([P.54B-149](#) ).

---

**STEP 5. Check the theft-alarm horn operation.****Q: Does the horn work normally by the theft-alarm system?**

**YES** : Replace the ETACS-ECU. The answerback function should work normally.

**NO** : Solve the problem first. Refer to Inspection Procedure M-2 ([P.54B-173](#) ).



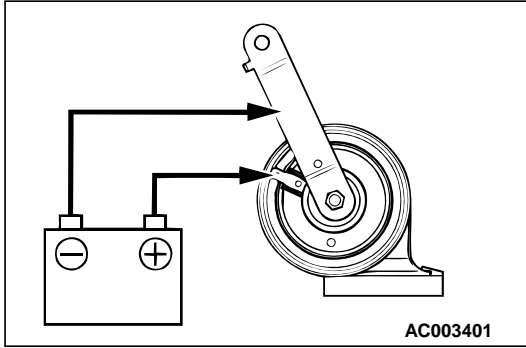

**STEP 6. Check the horn.**

The horn should sound when the battery is connected as shown in the illustration.

**Q: Does the horn sound?**

**YES :** Go to Step 7.

**NO :** Replace the horn. The answerback function should work normally.

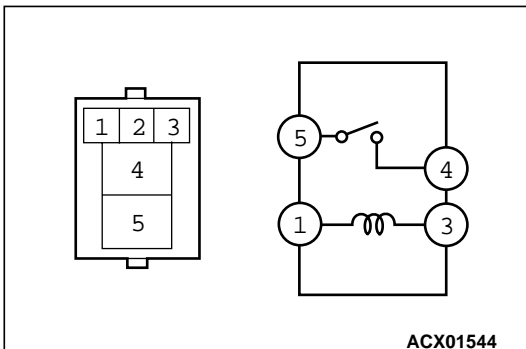

**STEP 7. Check the horn relay.**

BATTERY VOLTAGE	TESTER CONNECTION	SPECIFIED CONDITION
Not applied	1 – 3	Continuity
1 – Battery (+) terminal, 3 – Battery (-) terminal	4 – 5	Continuity

**Q: Is the theft-alarm horn relay in good condition?**

**YES :** Go to Step 8.

**NO :** Replace it. The answerback function should work normally.

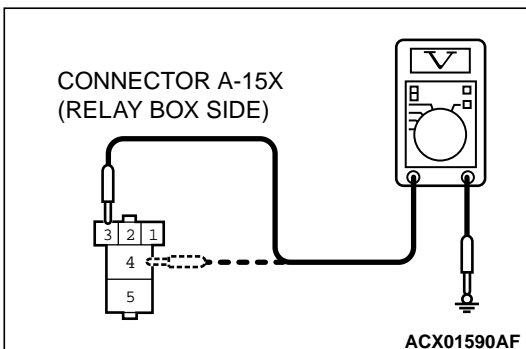

**STEP 8. Check the horn relay power supply circuit at the theft-alarm horn relay connector A-15X.**

(1) Disconnect the horn relay connector A-15X and measure at the relay box side.

(2) Measure the voltages between terminals 3, 4 and ground.

**Q: Are the voltages approximately 12 volts (battery positive voltage)?**

**YES :** Go to Step 11.

**NO :** Go to Step 9.

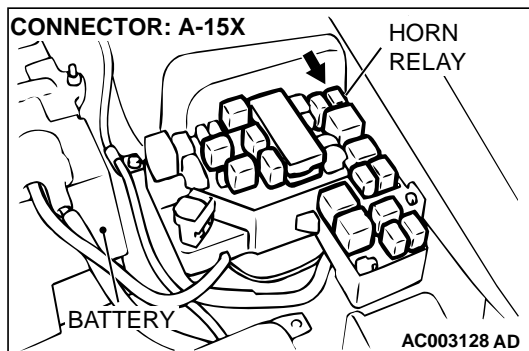
**STEP 9. Check the horn relay connector A-15X for damage.****Q: Is horn relay connector A-15X in good condition?****YES :** Go to Step 10.**NO :** Repair or replace it. Refer to GROUP 00E, Harness Connector Inspection [P.00E-2](#) . The answerback function should work normally.

**STEP 10. Check the harness wires between horn relay connector A-15X and fusible link (1).**

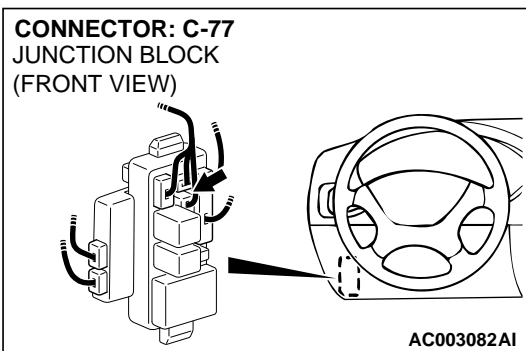
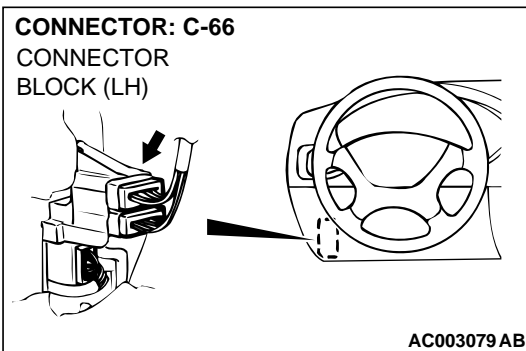
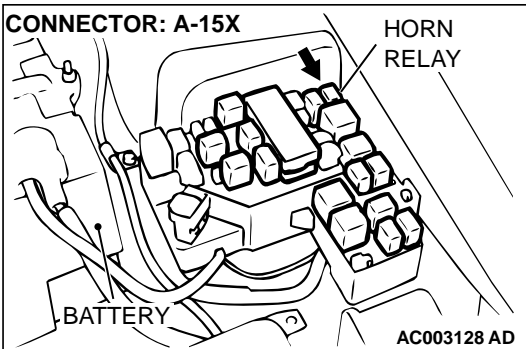
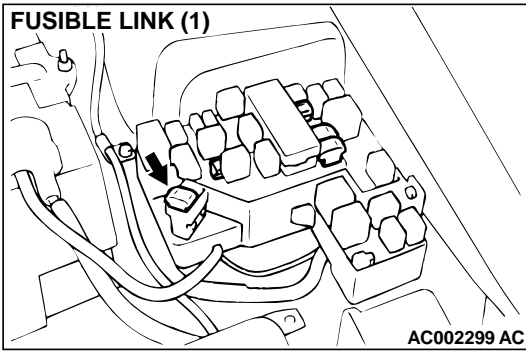

**CONNECTOR: C-85**  
JUNCTION BLOCK  
(REART VIEW)

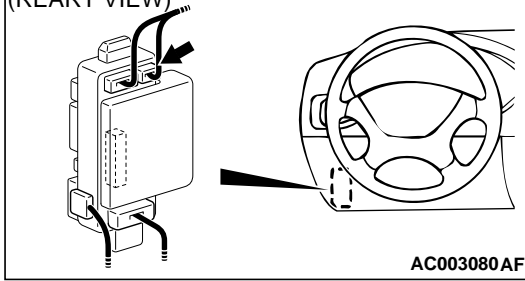

*NOTE: After checking intermediate connector C-66 and junction block connector C-77 and C-85, check the wires. If intermediate connector C-66 and junction block connector C-77 and C-85 are damaged, repair or replace them. Refer to GROUP 00E, Harness Connector Inspection [P.00E-2](#) .*

**Q: Are the harness wire between horn relay connector A-15X and fusible link (1) in good condition?**

**YES :** There is no action to be taken.

**NO :** Repair them. The answerback function should work normally.

**CONNECTOR: A-15X**

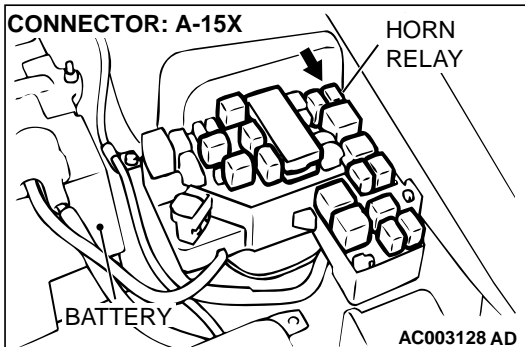

**STEP 11. Check the horn relay connector A-15X and ETACS-ECU connector C-81 for damage.**

**Q: Are horn relay connector A-15X and ETACS-ECU connector C-81 in good condition?**

**YES :** Go to Step 12.

**NO :** Repair or replace them. Refer to GROUP 00E, Harness Connector Inspection [P.00E-2](#) . The answerback function should work normally.

**CONNECTOR: C-81**  
JUNCTION BLOCK  
(FRONT VIEW)

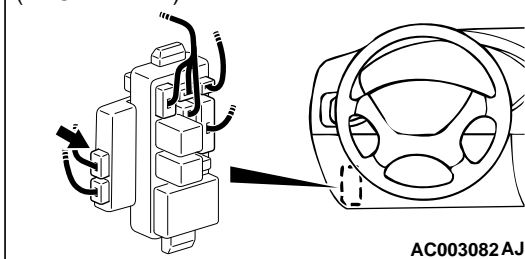

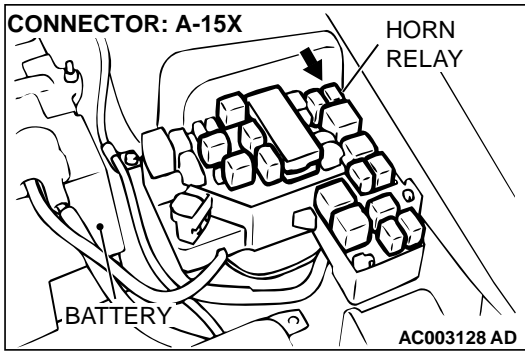

**STEP 12. Check the harness wires between horn relay connector A-15X and ETACS-ECU connector C-81.**

**NOTE:** After checking intermediate connector C-66, check the wires. If intermediate connector C-66 is damaged, repair or replace it. Refer to GROUP 00E, Harness Connector Inspection [P.00E-2](#).

**Q:** Are the harness wires between horn relay connector A-15X and ETACS-ECU connector C-81 in good condition?

**YES :** Go to Step 13.

**NO :** Repair them. The answerback function should work normally.

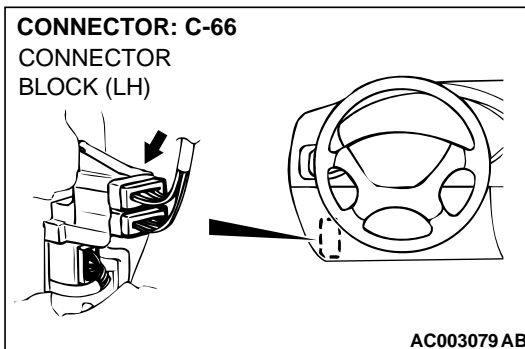
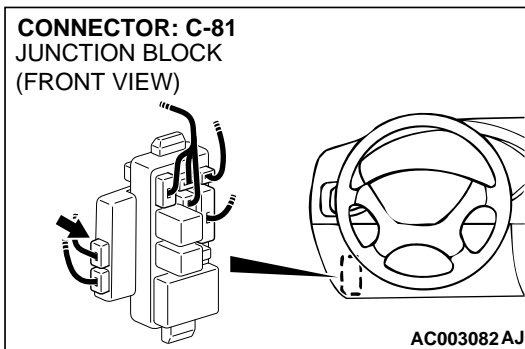

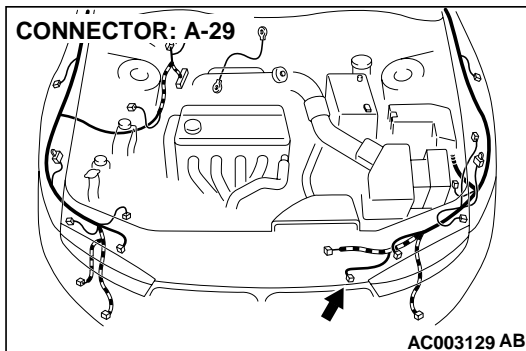
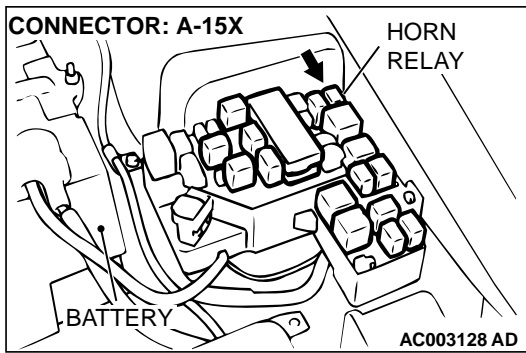

**STEP 13. Check the horn relay connector A-15X and horn connector A-29 for damage.**

**Q: Are horn relay connector A-15X and horn connector A-29 in good condition?**

**YES :** Go to Step 14.

**NO :** Repair or replace them. Refer to GROUP 00E, Harness Connector Inspection [P.00E-2](#) .The answerback function should work normally.

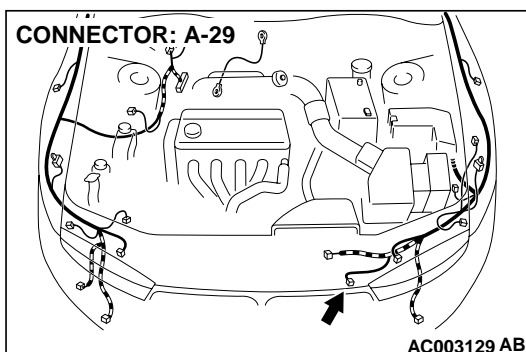
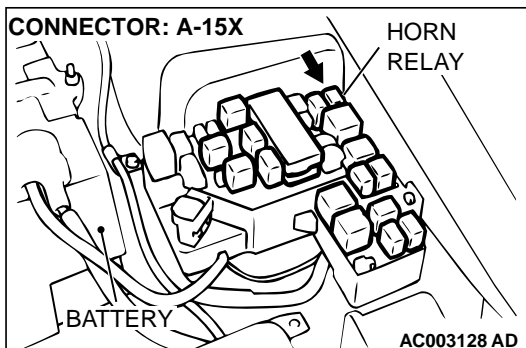

**STEP 14. Check the harness wire between horn relay connector A-15X and horn connector A-29.**

**Q: Is the harness wire between horn relay connector A-15X and horn connector A-29 in good condition?**

**YES :** Go to Step 15.

**NO :** Repair it. The answerback function should work normally.

---

**STEP 15. Check that the horn is installed properly.**

*NOTE: The horn is grounded to the body through the installation bolts.*

**Q: Is the horn installation in good condition?**

**YES :** Replace the ETACS-ECU. The answerback function should work normally.

**NO :** Repair it. The answerback function should work normally.

---

**Inspection Procedure E-3: Keyless entry system: Encrypted code cannot be registered**

---

**TECHNICAL DESCRIPTION (COMMENT)**

The ETACS-ECU activates the encrypted code register mode according to the following switch signals:

- Key reminder switch
- Hazard warning light switch

If the encrypted code register mode is not set, the relevant input signal circuit or the ETACS-ECU may be defective.

If a transmitter can not be registered although the encrypted code register mode is set, the transmitter or the ETACS-ECU may be defective.

**TROUBLESHOOTING HINTS**

- Malfunction of the key reminder switch
- Malfunction of the hazard warning light switch
- Malfunction of the transmitter
- Malfunction of the ETACS-ECU
- Damaged harness wires or connectors

**DIAGNOSIS**

**Required Special Tools:**

- MB991502: Scan Tool (MUT-II)
- MB991529: Diagnostic Trouble Code Check Harness

---

**STEP 1. Check the trouble symptom.**

**Q: Is the encrypted code register mode set?**

**YES :** Go to Step 4.

**NO :** Go to Step 2 <when using scan tool MB991502> or 3 <when using a volt meter>.

**STEP 2. Check the input signal (by using scan tool MB991502).**

Check the input signals from the following switches:

- Key reminder switch
- Hazard warning light switch

**⚠ CAUTION**

To prevent damage to scan tool MB991502, always turn the ignition switch to the "LOCK" (OFF) position before connecting or disconnecting scan tool MB991502.

- (1) Connect scan tool MB991502 to the data link connector.
- (2) Check that the tone alarm of scan tool MB991502 sounds when the input signal enters.

**Q: Does the tone alarm of scan tool MB991502 sound when the input signal enters?**

**YES :** Replace the ETACS-ECU. Check that the transmitter can be registered.

**NO :** Check the relevant input circuit. Refer to [P.54B-9](#).

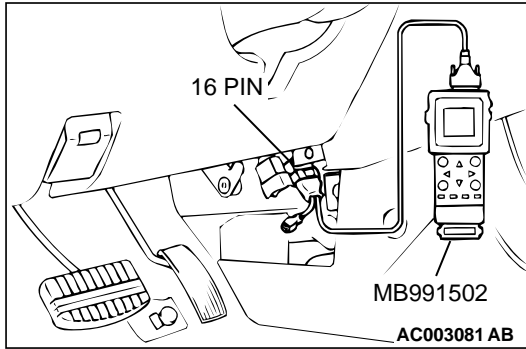
**STEP 3. Check the input signal (by using a voltmeter).**

Check the input signals from the following switches:

- Key reminder switch
- Hazard warning light switch

- (1) Use special tool MB991529 to connect a voltmeter between ground terminal 4 or 5 and ETACS-ECU terminal 9 of the data link connector.
- (2) Check that the voltmeter indicator deflects once when the input signal enters.

**Q: Does the voltmeter indicator deflect?**

**YES :** Replace the ETACS-ECU. Check that the transmitter can be registered.

**NO :** Check the relevant input circuit. Refer to [P.54B-9](#).

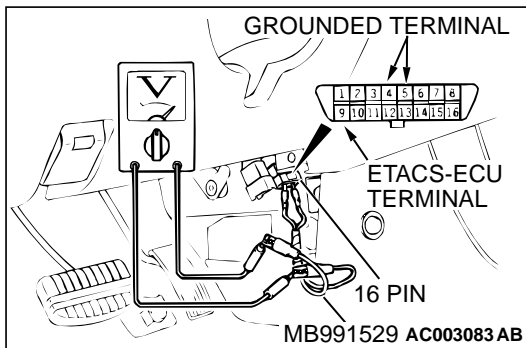
**STEP 4. Check the transmitter.****Q: Can the encrypted code be registered when the transmitter battery has been renewed?**

**YES :** There is no action to be taken.

**NO :** Replace the transmitter. If the transmitter can not be registered even if the transmitter has been replaced, replace the ETACS-ECU. Check that the transmitter can be registered.



Inspection Procedure F-1: Windshield wiper and washer: Windshield wiper does not operate.

Windshield Wiper Motor Driver Circuit

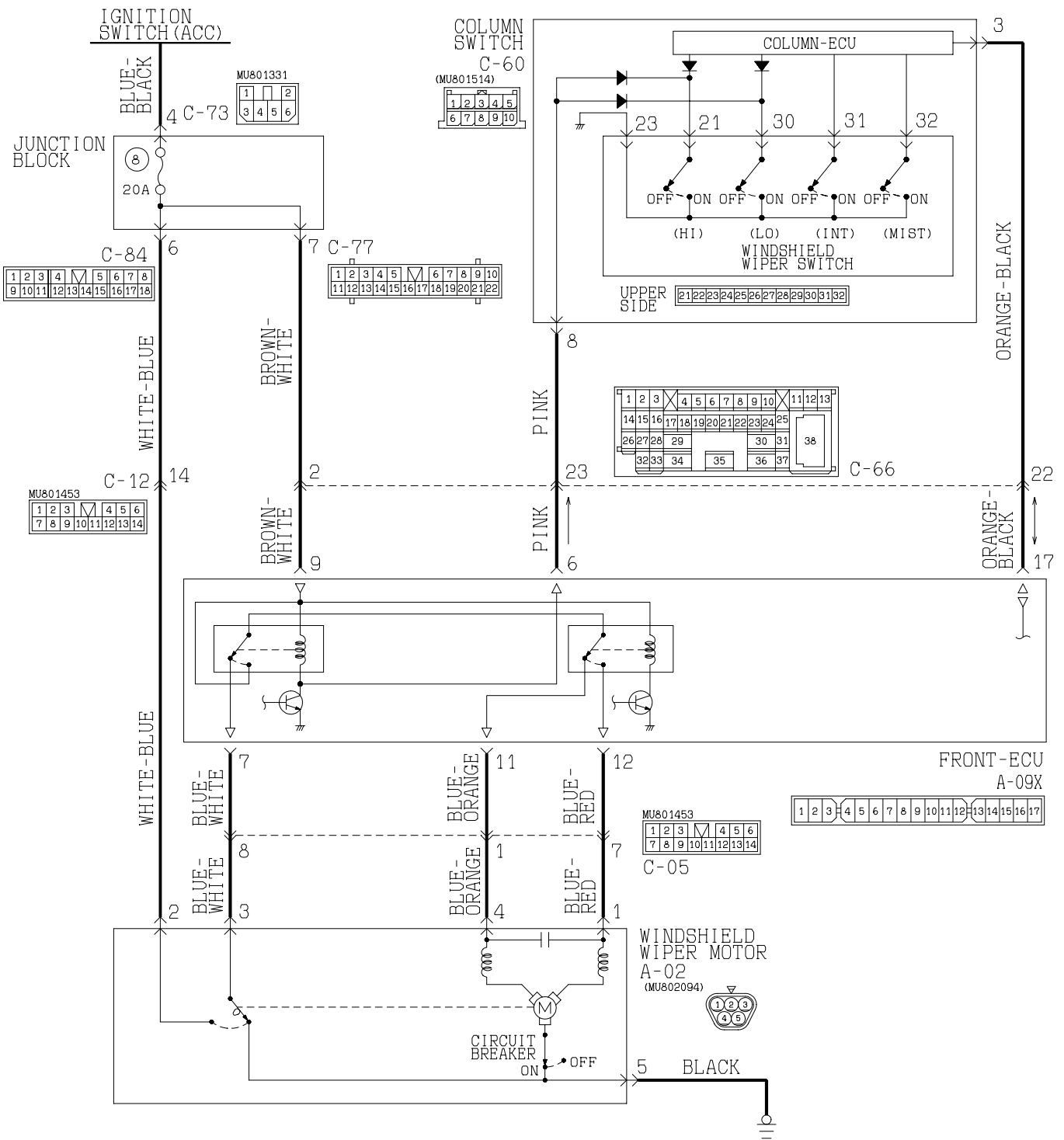

W1809M08AA  
AC004370

TSB Revision

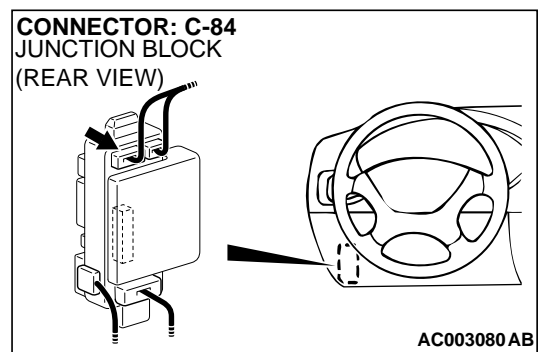
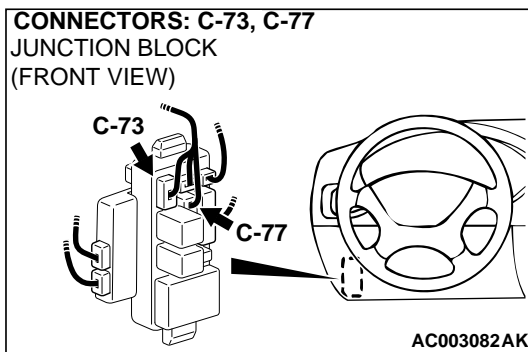
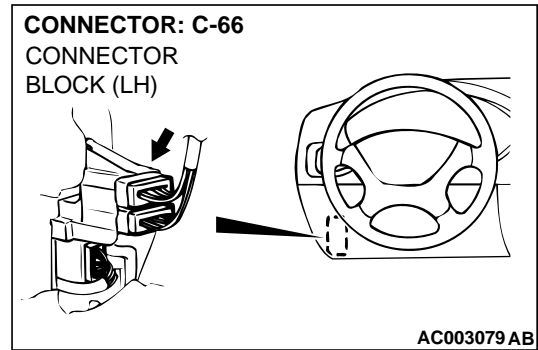
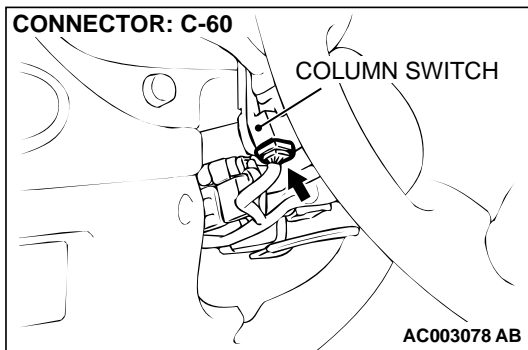
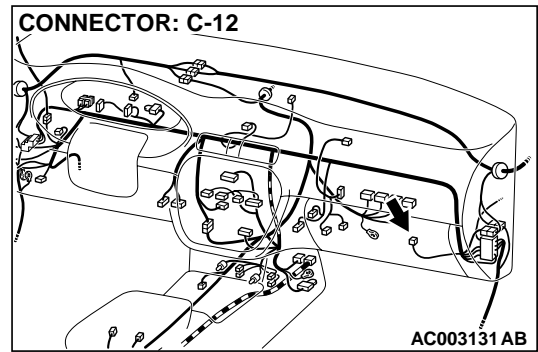
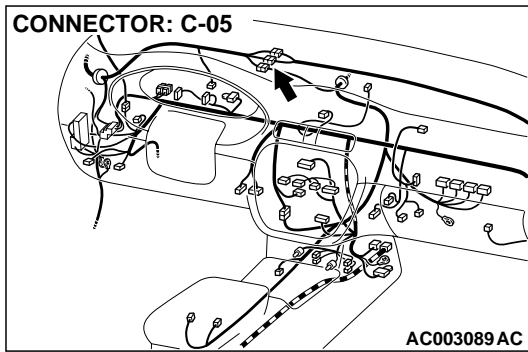
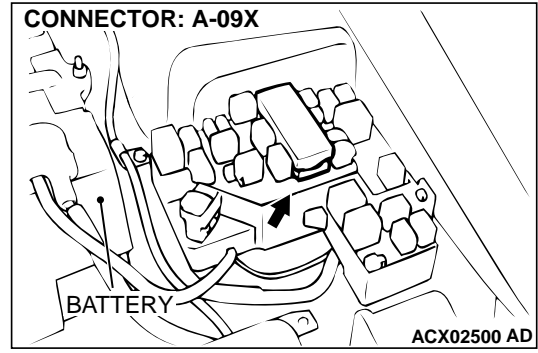
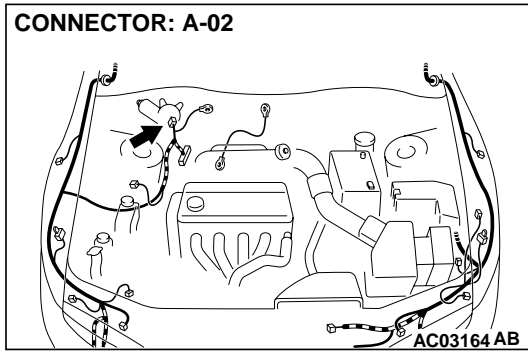

**CIRCUIT OPERATION**

- A signal from the windshield wiper switch is sent through the column-ECU inside the column switch to the front-ECU. The signal turns on the relay inside the front-ECU to operate the wiper motor.

- If the SWS communication line is defective, another signal line (wiper back-up circuit) will be active. In that case, the windshield wiper will operate at low-speed when the windshield wiper switch is in the "LO" or "HIGH" position.

**TECHNICAL DESCRIPTION (COMMENT)**

If the windshield wiper does not work at all, the wiper

motor, column switch (windshield wiper and washer switch) or the front-ECU may be defective.

**TROUBLESHOOTING HINTS**

- Malfunction of the wiper motor
- Malfunction of the column switch (windshield wiper and washer switch)
- Malfunction of the front-ECU
- Damaged harness wires and connectors

**DIAGNOSIS**

**Required Special Tools:**

- MB991223: Test Harness Set
- MB991502: Scan Tool (MUT-II)
- MB991529: Diagnostic Trouble Code Check Harness

**STEP 1. Check method of the input signal**

**Q: Which is to be used, the scan tool or the voltmeter to check the input signal?**

**Scan tool MB991502 :** Go to Step 2.

**Voltmeter :** Go to Step 3.

**STEP 2. Check the input signal (by using scan tool MB991502).**

Check the input signals from the windshield wiper switches.

**⚠ CAUTION**

**To prevent damage to scan tool MB991502, always turn the ignition switch to the "LOCK" (OFF) position before connecting or disconnecting scan tool MB991502.**

- (1) Connect scan tool MB991502 to the data link connector.
- (2) Check that the tone alarm of scan tool MB991502 sounds when the input signal enters.

**Q: Does the tone alarm of scan tool MB991502 sounds when the input signal enters?**

**YES :** Go to Step 4.

**NO :** Check the windshield wiper switch input circuit. Refer to Inspection Procedure N-15 (P.54B-260).

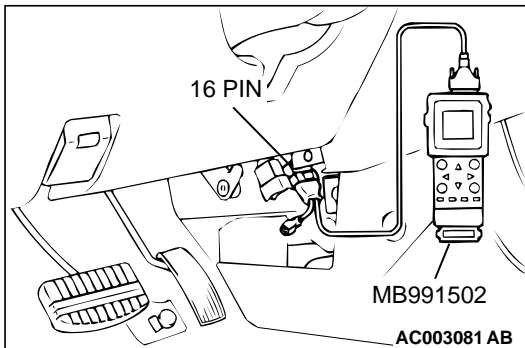

**STEP 3. Check the input signal (by using a voltmeter).**

Check the input signals from the windshield wiper switches.

- (1) Use special tool MB991529 to connect a voltmeter between ground terminal 4 or 5 and ETACS-ECU terminal 9 of the data link connector.
- (2) Check that the voltmeter indicator deflects once when the input signal enters.

**Q: Does the voltmeter indicator deflect?**

**YES :** Go to Step 4.

**NO :** Check the windshield wiper switch input circuit. Refer to Inspection Procedure N-15 P.54B-260).

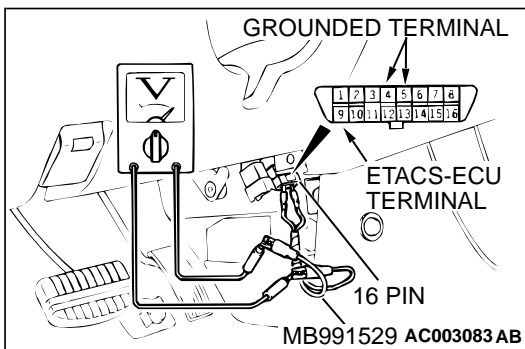

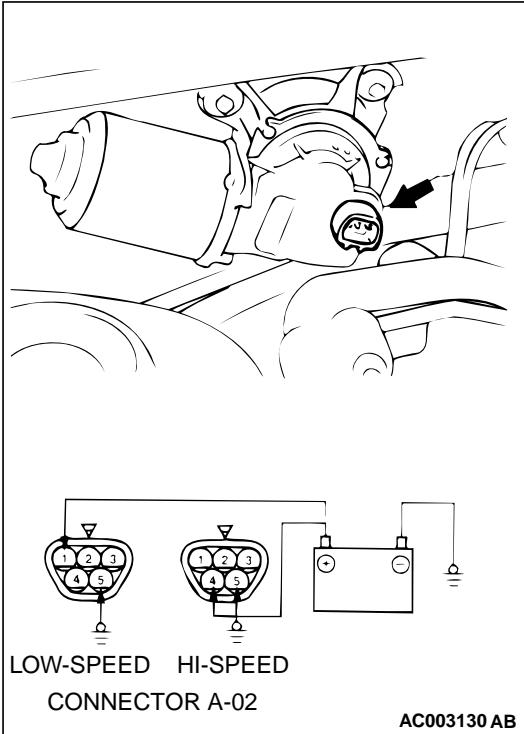

**STEP 4. Check the windshield wiper motor.**

- (1) Disconnect the wiper motor connector A-02.
- (2) Connect a battery to the wiper motor as shown in the illustration and check motor operation at low-speed and high-speed.

**Q: Is the wiper motor in good condition?**

**YES :** Go to Step 5.

**NO :** Replace the wiper motor. The windshield wiper should work normally.

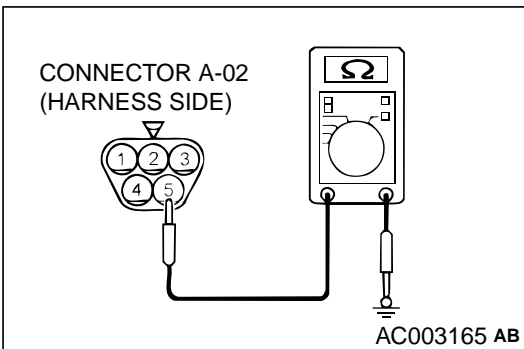

**STEP 5. Check the wiper motor ground circuit at wiper motor connector A-02.**

- (1) Disconnect wiper motor connector A-02 and measure at the harness side.
- (2) Measure the resistance between terminal 5 and ground.

**Q: Is the resistance less than 2 ohm?**

**YES :** Go to Step 8.

**NO :** Go to Step 6.

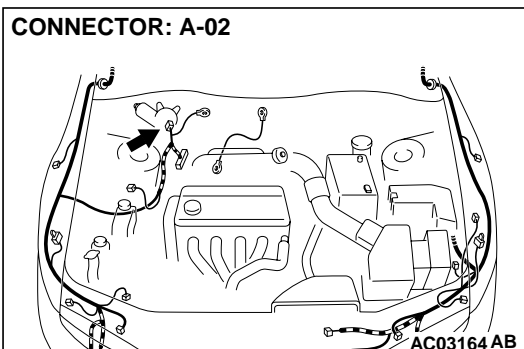

**STEP 6. Check wiper motor connector A-02 for damage.**

**Q: Is wiper motor connector A-02 in good condition?**

**YES :** Go to Step 7.

**NO :** Repair or replace it. Refer to GROUP 00E, Harness Connector Inspection [P.00E-2](#) . The windshield wiper should work normally.

CONNECTOR: A-02

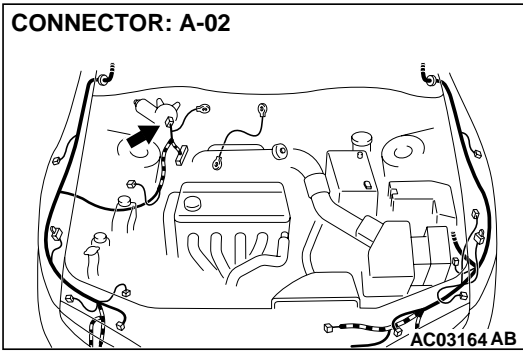

**STEP 7. Check the harness wire between wiper motor connector A-02 and ground.**

**Q: Is the harness wire between wiper motor connector A-02 and ground in good condition?**

**YES :** There is no action to be taken.

**NO :** Repair it. The windshield wiper should work normally.

**STEP 8. Check the front-ECU power supply circuit [ignition switch (ACC)] at the front-ECU connector A-09X.**

(1) Disconnect the front-ECU connector A-09X and measure at the relay box side.

(2) Turn the ignition switch to "ACC" position.

(3) Measure the voltage between terminal 9 and ground.

**Q: Is the voltage approximately 12 volts (battery positive voltage)?**

**YES :** Replace the front-ECU. The windshield wiper should work normally.

**NO :** Go to Step 9.

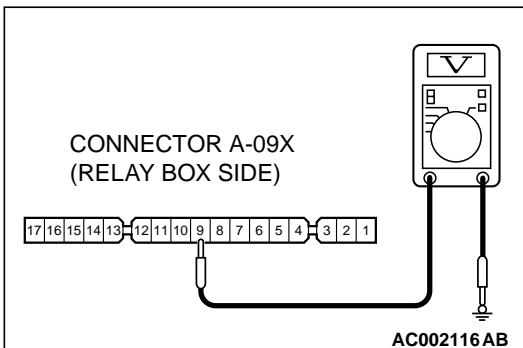

CONNECTOR: A-09X

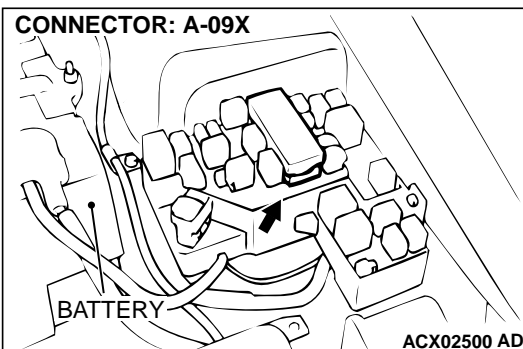

**STEP 9. Check front-ECU connector A-09X for damage.**

**Q: Is front-ECU connector A-09X in good condition?**

**YES :** Go to Step 10.

**NO :** Repair or replace it. Refer to GROUP 00E, Harness Connector Inspection [P.00E-2](#) . The windshield wiper should work normally.

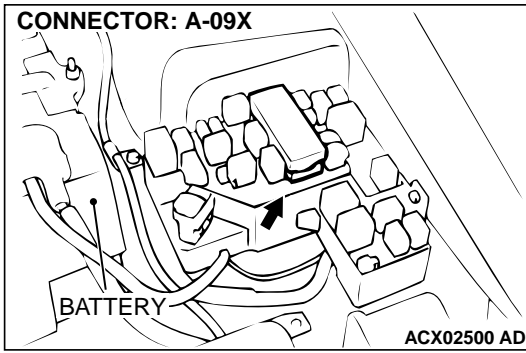

**STEP 10. Check the harness wires between front-ECU connector A-09X and ignition switch (ACC).**

*NOTE: After checking intermediate connector C-66 and junction block connectors C-73 and C-77, check the wires. If intermediated connector C-66 and junction block connectors C-73 and C-77 are damaged, repair or replace them. Refer to GROUP 00E, Harness Connector Inspection P.00E-2 .*

**Q: Are the harness wires between front-ECU connector A-09X and ignition switch (ACC) in good condition?**

**YES :** There is no action to be taken.

**NO :** Repair them. The windshield wiper should work normally.

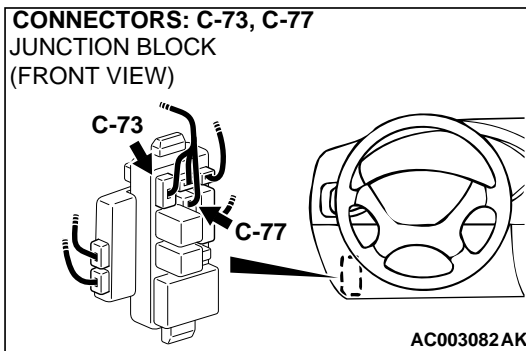
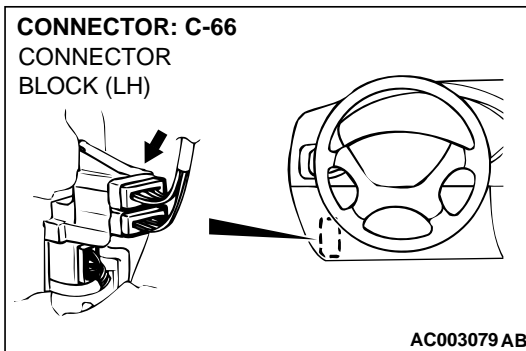

**Inspection Procedure F-2: Windshield wiper and washer: Any of the windshield wiper switch positions is defective.**

**ANY OF THE WINDSHIELD WIPER SWITCH POSITIONS IS DEFECTIVE.**

- Refer to Inspection Procedure F-1 (P.54B-82).

**CIRCUIT OPERATION**

A signal from the windshield wiper switch is sent through the column-ECU inside the column switch to the front-ECU. The signal turns on the relay inside the front-ECU to operate the wiper motor.

**TECHNICAL DESCRIPTION (COMMENT)**

The wiper motor, column switch (windshield wiper and washer switch) or the front-ECU may be defective.

**TROUBLESHOOTING HINTS**

- Malfunction of the wiper motor
- Malfunction of the column switch (windshield wiper and washer switch)
- Malfunction of the front-ECU
- Damaged harness wires and connectors

**DIAGNOSIS**

**Required Special Tools:**

- MB991223: Test Harness Set
- MB991502: Scan Tool (MUT-II)
- MB991529: Diagnostic Trouble Code Check Harness

**STEP 1. Check method of the input signal**

**Q: Which is to be used, the scan tool or the voltmeter to check the input signal?**

**Scan tool MB991502 :** Go to Step 2.

**Voltmeter :** Go to Step 3.

**STEP 2. Check the input signal (by using scan tool MB991502).**

Check the input signals from the windshield wiper switches.

**⚠ CAUTION**

**To prevent damage to scan tool MB991502, always turn the ignition switch to the "LOCK" (OFF) position before connecting or disconnecting scan tool MB991502.**

- (1) Connect scan tool MB991502 to the data link connector.
- (2) Check that the tone alarm of scan tool MB991502 sounds when the input signal enters.

**Q: Does the tone alarm of scan tool MB991502 sound when the input signal enters?**

**YES :** Go to Step 4.

**NO :** Check the windshield wiper switch input circuit. Refer to Inspection Procedure N-15 (P.54B-260).

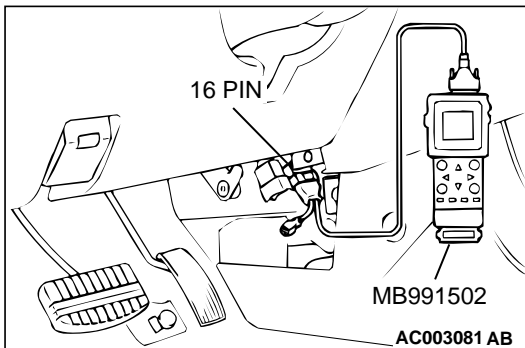

**STEP 3. Check the input signal (by using a voltmeter).**

Check the input signals from the windshield wiper switches.

- (1) Use special tool MB991529 to connect a voltmeter between ground terminal 4 or 5 and ETACS-ECU terminal 9 of the data link connector.
- (2) Check that the voltmeter indicator deflects once when the input signal enters.

**Q: Does the voltmeter indicator deflect?**

**YES :** Go to Step 4.

**NO :** Check the windshield wiper switch input circuit. Refer to Inspection Procedure N-15 (P.54B-260).

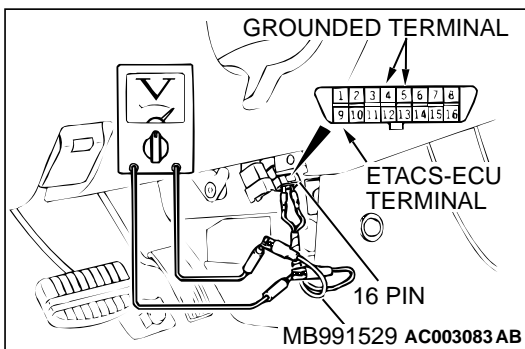

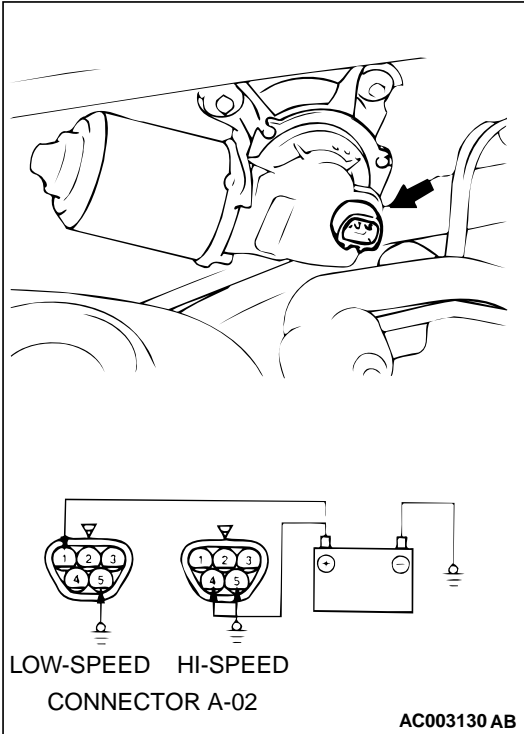
**STEP 4. Check the windshield wiper motor.**

- (1) Disconnect the wiper motor connector A-02.
- (2) Connect a battery to the wiper motor as shown in the illustration and check motor operation at low-speed and high-speed.

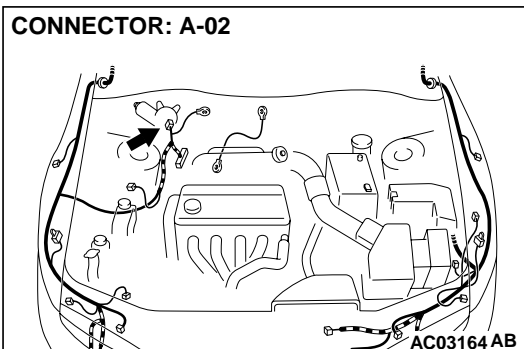
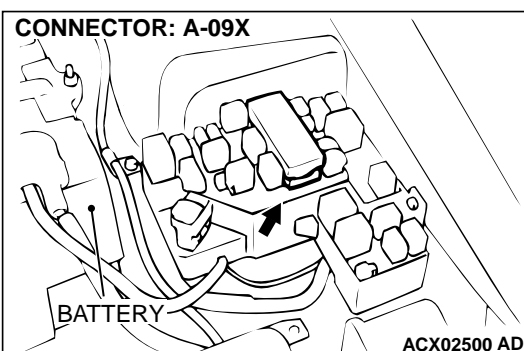
**Q: Is the wiper motor in good condition?****YES** : Go to Step 5.**NO** : Replace the wiper motor. The windshield wiper should work normally when the windshield wiper switch is set to all positions.**STEP 5. Check the wiper motor connector A-02 and front-ECU connector A-09X for damage.****Q: Are wiper motor connector A-02 and front-ECU connector A-09X in good condition?****YES** : Go to Step 6.**NO** : Repair or replace them. Refer to GROUP 00E, Harness Connector Inspection [P.00E-2](#) . The windshield wiper should work normally when the windshield wiper switch is set to all positions.



CONNECTOR: A-02

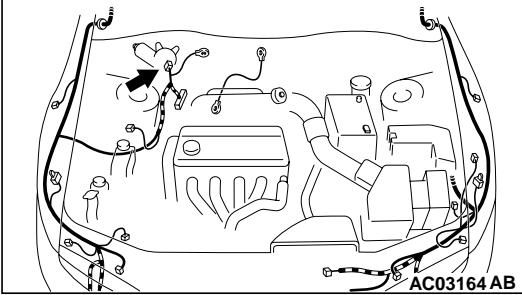

CONNECTOR: A-09X

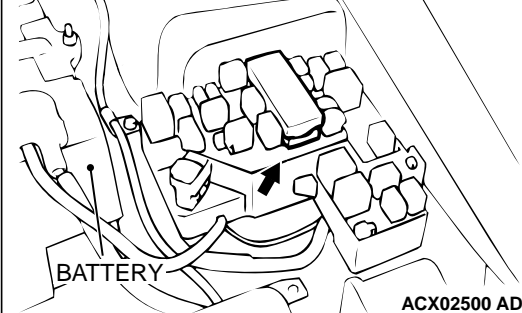

CONNECTOR: C-23

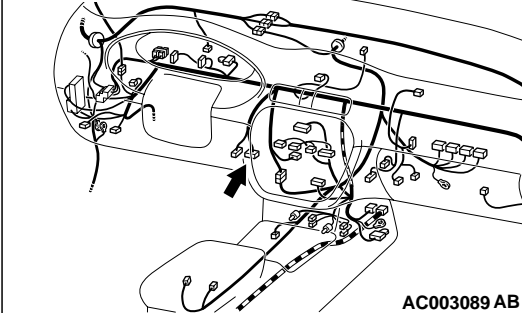

**STEP 6.** Check the harness wires between wiper motor connector A-02 and front-ECU connector A-09X.

*NOTE:* After checking intermediate connector C-05, check the wires. If intermediate connector C-05 is damaged, repair or replace it. Refer to GROUP 00E, Harness Connector Inspection P.00E-2 .

**Q:** Are the harness wires between wiper motor connector A-02 and front-ECU connector A-09X in good condition?

**YES :** There is no action to be taken.

**NO :** Repair them. The windshield wiper should work normally when the windshield wiper switch is set to all positions.

**Inspection Procedure F-3: Windshield wiper and washer: Windshield wiper does not stop at the predetermined park position.**

**WINDSHIELD WIPER Motor Driver Circuit.**

- Refer to Inspection Procedure F-1 (P.54B-82).

**CIRCUIT OPERATION**

A signal from the windshield wiper switch is sent through the column-ECU inside the column switch to the front-ECU. The signal turns on the relay inside the front-ECU to operate the wiper motor.

**TECHNICAL DESCRIPTION (COMMENT)**

The wiper motor or the front-ECU may be defective.

**TROUBLESHOOTING HINTS**

- Malfunction of the wiper motor
- Malfunction of the front-ECU
- Damaged harness wires and connectors

## DIAGNOSIS

## Required Special Tool:

- MB991223: Test Harness Set

**STEP 1. Check the windshield wiper motor**

- (1) Disconnect the wiper motor connector A-02.
- (2) Run the wiper motor at low-speed, disconnect the battery, and stop the motor.
- (3) Reconnect the battery as shown in the illustration, and confirm that after the motor starts turning at low-speed, and stops at the automatic stop position.

**Q: Is the wiper motor in good condition?**

**YES** : Go to Step 2.

**NO** : Replace the wiper motor. The windshield wiper should stop at the predetermined park position.

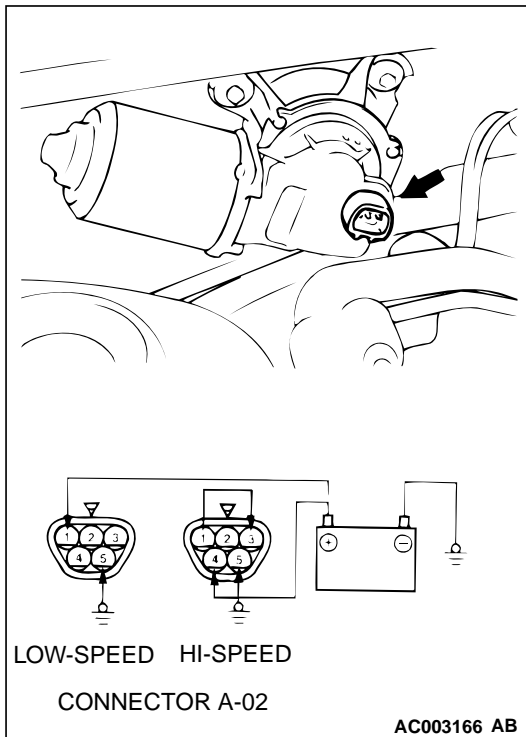
**STEP 2. Check the wiper motor power supply circuit at the wiper motor connector A-02 by backprobing.**

- (1) Do not disconnect the wiper motor connector A-02.
- (2) Turn the ignition switch to "ACC" position.
- (3) Measure the voltage between terminal 2 and ground by backprobing.

**Q: Is the voltage approximately 12 volts (battery positive voltage)?**

**YES** : Go to Step 5.

**NO** : Go to Step 3.

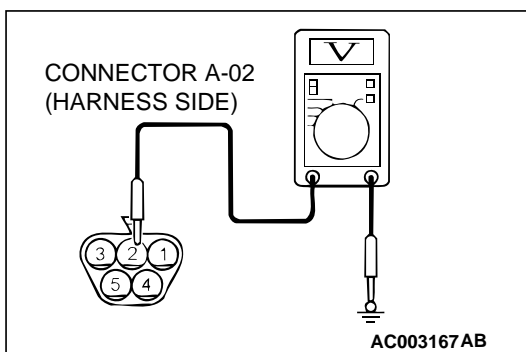

CONNECTOR: A-02

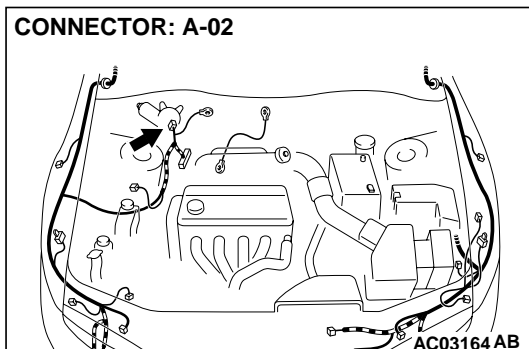

**STEP 3. Check wiper motor connector A-02 for damage.**

**Q: Is wiper motor connector A-02 in good condition?**

**YES :** Go to Step 4.

**NO :** Repair or replace it. Refer to GROUP 00E, Harness Connector Inspection [P.00E-2](#) . The windshield wiper should stop at the predetermined park position.

CONNECTOR: A-02

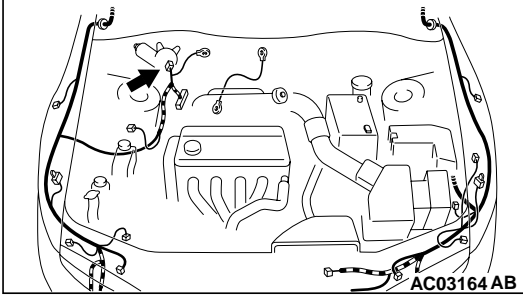

CONNECTOR: C-12

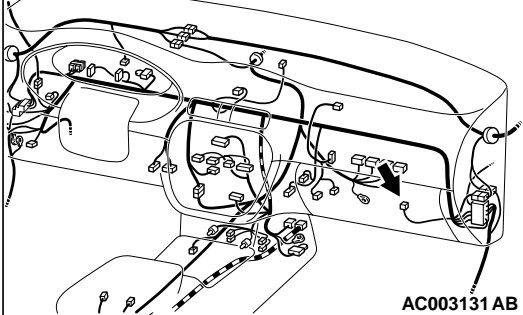
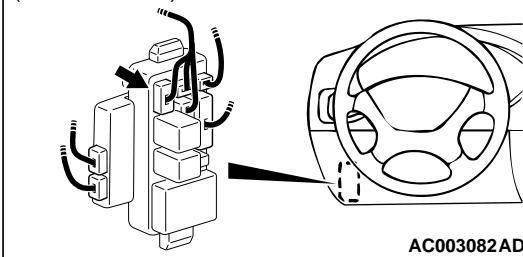
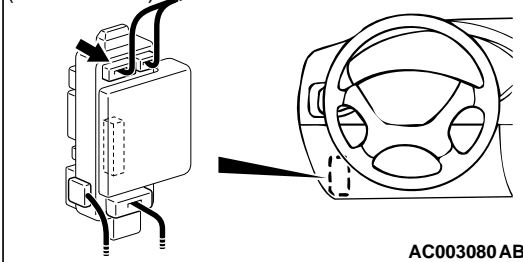
CONNECTOR: C-73  
JUNCTION BLOCK  
(FRONT VIEW)CONNECTOR: C-84  
JUNCTION BLOCK  
(REAR VIEW)**STEP 4. Check the harness wires between wiper motor connector A-02 and ignition switch (ACC).**

**NOTE:** After checking intermediate connector C-12 and junction block connectors C-73 and C-84, check the wires. If intermediate connector C-12 and junction block connectors C-73 and C-84 are damaged, repair or replace them. Refer to GROUP 00E, Harness Connector Inspection P.00E-2 .

**Q:** Are the harness wires between wiper motor connector A-02 and ignition switch (ACC) in good condition?

**YES :** There is no action to be taken.

**NO :** Repair or replace them. The windshield wiper should stop at the predetermined park position.

**STEP 5.** Check the wiper motor connector A-02 and front-ECU connector A-09X for damage.

**Q:** Are wiper motor connector A-02 and front-ECU connector A-09X in good condition?

**YES :** Go to Step 6.

**NO :** Repair or replace them. Refer to GROUP 00E, Harness Connector Inspection [P.00E-2](#) . The windshield wiper should stop at the predetermined park position.

CONNECTOR: A-02

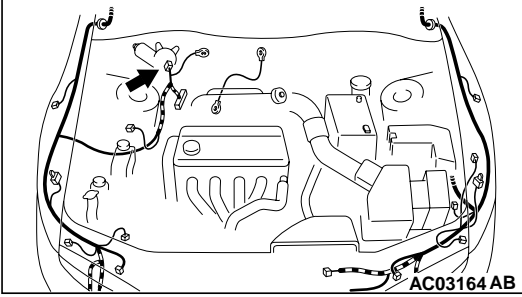

CONNECTOR: A-09X

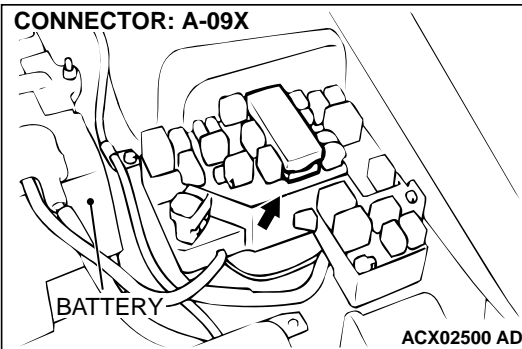

CONNECTOR: A-02

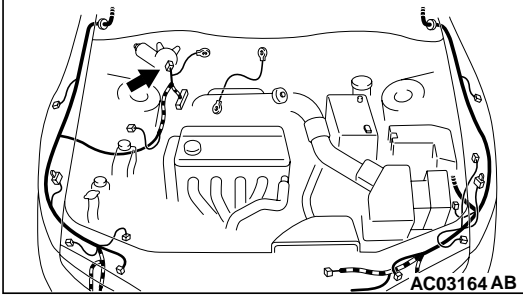

CONNECTOR: A-09X

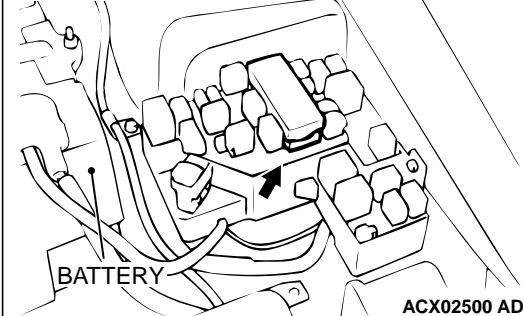

CONNECTOR: C-05

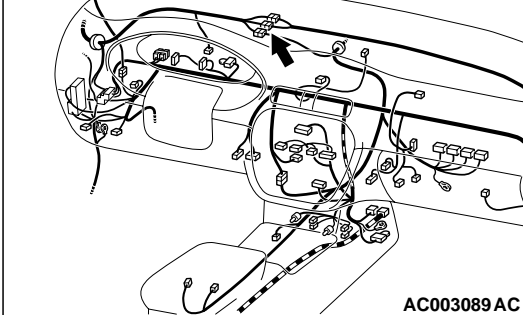

**STEP 6. Check the harness wires between wiper motor connector A-02 and front-ECU connector A-09X.**

**NOTE:** After checking intermediate connector C-05, check the wires. If intermediate connector C-05 is damaged, repair or replace it. Refer to GROUP 00E, Harness Connector Inspection P.00E-2 .

**Q: Is the harness wires between wiper motor connector A-02 and front-ECU connector A-09X in good condition?**

**YES :** There is no action to be taken.

**NO :** Repair them. The windshield wiper should stop at the predetermined park position.

**Inspection Procedure F-4: Windshield wiper and washer: Windshield intermittent wiper interval cannot be adjusted.**

#### TECHNICAL DESCRIPTION (COMMENT).

The ETACS-ECU calculates the intermittent wiper interval, and sends a signal to the front-ECU through the SWS communication line. If the signal is defective, the front-ECU will ignore the signal and set the intermittent wiper interval to four seconds.

#### TROUBLESHOOTING HINTS

- Malfunction of speed sensor
- Malfunction of the column switch (windshield wiper and washer switch)
- Malfunction of the ETACS-ECU
- Malfunction of the front-ECU
- Damaged harness wires or connectors

#### DIAGNOSIS

##### Required Special Tools:

- MB991502: Scan Tool (MUT-II)
- MB991529: Diagnostic Trouble Code Check Harness

**STEP 1. Check method of the input signal**

**Q: Which is to be used, the scan tool or the voltmeter to check the input signal?**

**Scan tool MB991502 :** Go to Step 2.

**Voltmeter :** Go to Step 3.

**STEP 2. Check the input signal (by using scan tool MB991502).**

Check the input signals from the Windshield intermittent wiper interval adjusting knob switches.

*NOTE: If the windshield intermittent wiper interval adjusting knob is rotated from "FAST" to "SLOW" when the ignition switch is at the "ON" position, the ETACS-ECU will send a signal around the medium knob position.*

**⚠ CAUTION**

**To prevent damage to scan tool MB991502, always turn the ignition switch to the "LOCK" (OFF) position before connecting or disconnecting scan tool MB991502.**

- (1) Connect scan tool MB991502 to the data link connector.
- (2) Check that the tone alarm of scan tool MB991502 sounds when the input signal enters.

**Q: Does the tone alarm of scan tool MB991502 sound when the input signal enters?**

**YES :** Go to Step 4.

**NO :** Check the relevant input circuit. Refer to [P.54B-9](#).

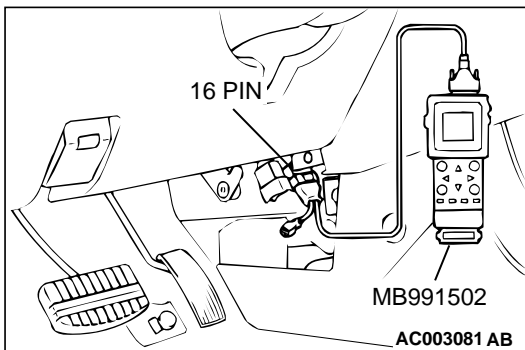

**STEP 3. Check the input signal (by using a voltmeter).**

Check the input signals from the Windshield intermittent wiper interval adjusting knob switches.

*NOTE: If the windshield intermittent wiper interval adjusting knob is rotated from "FAST" to "SLOW" when the ignition switch is at the "ON" position, the ETACS-ECU will send a signal around the medium knob position.*

- (1) Use special tool MB991529 to connect a voltmeter between ground terminal 4 or 5 and ETACS-ECU terminal 9 of the data link connector.
- (2) Check that the voltmeter indicator deflects once when the input signal enters.

**Q: Does the voltmeter indicator deflect?**

**YES :** Go to Step 4.

**NO :** Check the relevant input circuit. Refer to [P.54B-9](#).

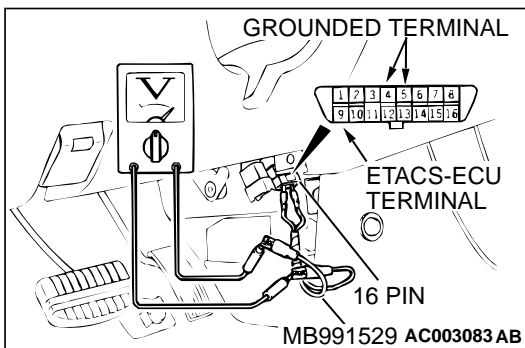

**STEP 4. Replacement of ECU**

- (1) Replace the front-ECU.
- (2) The windshield intermittent wiper interval should be changed.

**Q: Is it possible to adjust the windshield intermittent wiper interval?**

**YES :** There is no action to be taken.

**NO :** Replace the ETACS-ECU. The windshield intermittent wiper interval should be changed.



**Inspection Procedure F-5: Windshield wiper and washer: Windshield washer does not work.**

**Windshield Washer Motor Driver Circuit**

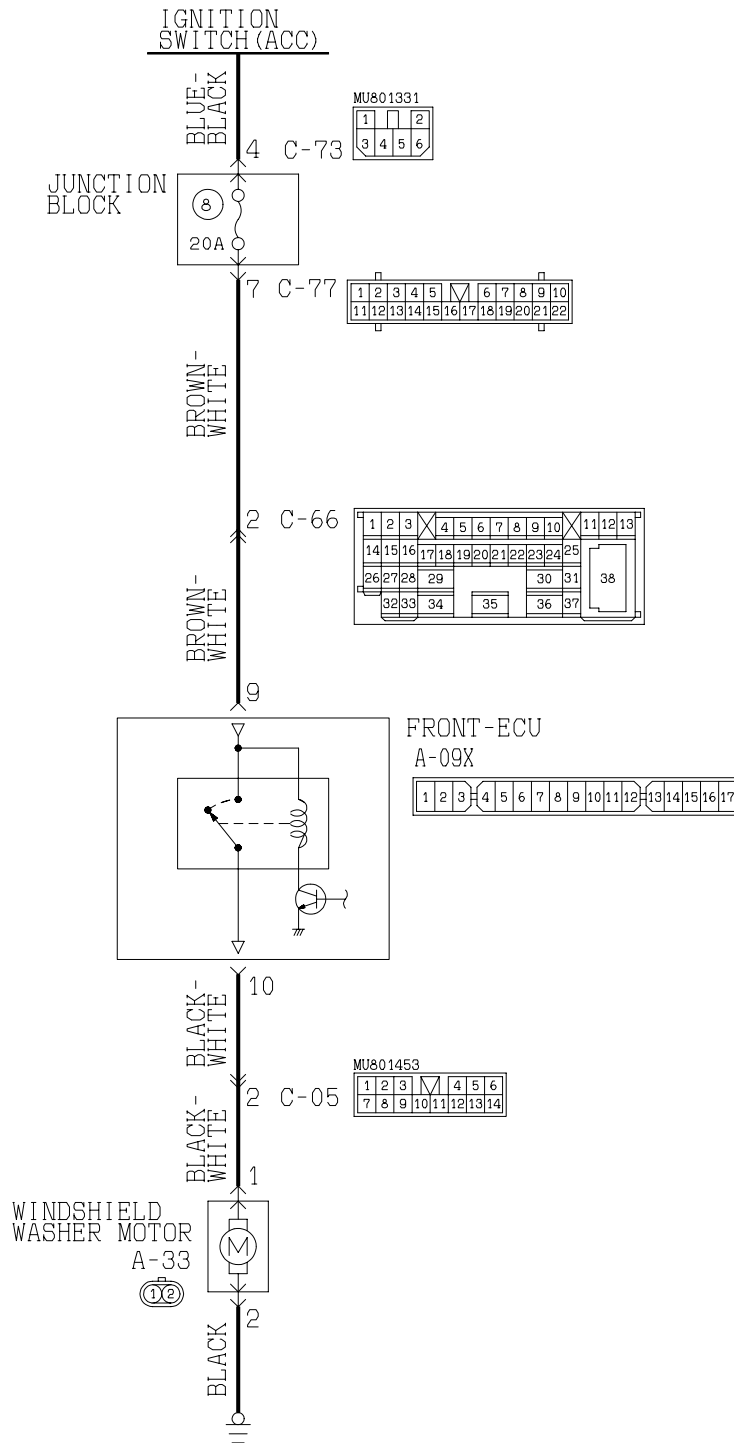

W1S09M09AA  
AC004207

**TSB Revision**

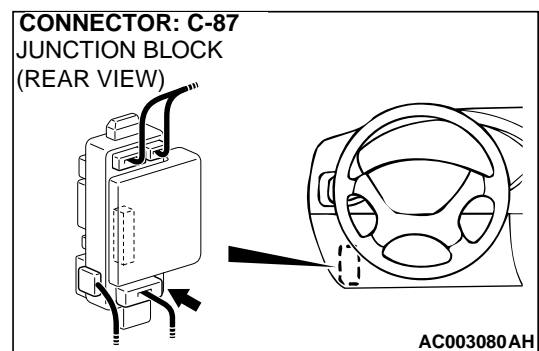
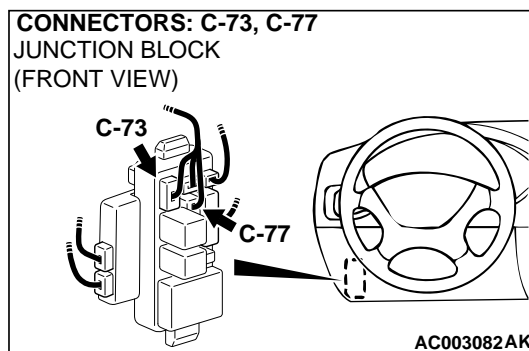
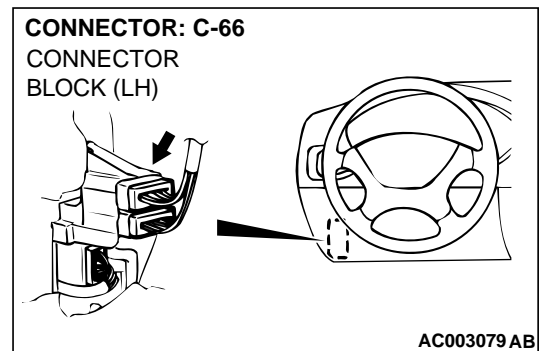
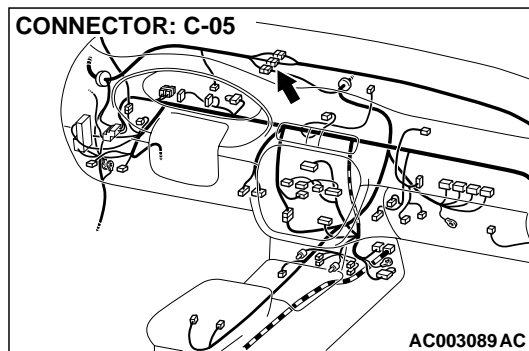
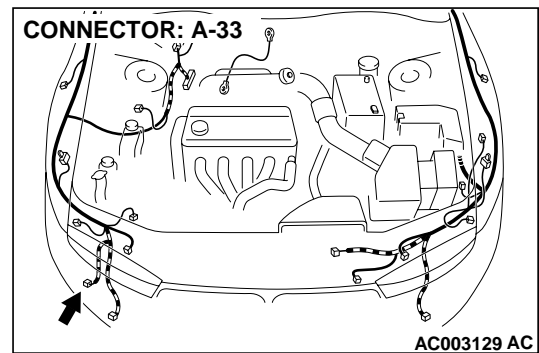
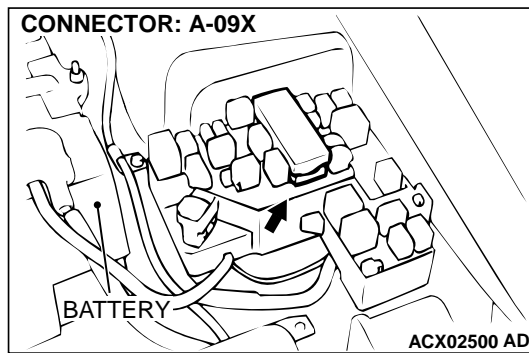

### CIRCUIT OPERATION

A signal from the windshield washer switch is sent through the column-ECU inside the column switch to the front-ECU. The signal turns on the relay inside the front-ECU to operate the washer motor.

### TECHNICAL DESCRIPTION (COMMENT)

The washer motor, the column switch (windshield wiper and washer switch) or the front-ECU may be defective.

### TROUBLESHOOTING HINTS

- Malfunction of the washer motor
- Malfunction of the column switch (windshield wiper and washer switch)
- Malfunction of the front-ECU
- Damaged harness wires and connectors

### DIAGNOSIS

#### Required Special Tools:

- MB991223: Test Harness Set
- MB991502: Scan Tool (MUT-II)
- MB991529: Diagnostic Trouble Code Check Harness

**STEP 1. Check the windshield wiper operation.**

**Q: Does the windshield wiper work normally?**

**YES :** Go to Step 2 <when using scan tool MB991502> or 3 <when using a voltmeter>.

**NO :** Solve the problem first. Refer to [P.54B-82](#).

**STEP 2. Check the input signal (by using scan tool MB991502).**

Check the input signal from the windshield washer switch.

**⚠ CAUTION**

To prevent damage to scan tool MB991502, always turn the ignition switch to the "LOCK" (OFF) position before connecting or disconnecting scan tool MB991502.

- (1) Connect scan tool MB991502 to the data link connector.
- (2) Check that the tone alarm of scan tool MB991502 sounds when the input signal enters.

**Q: Does the tone alarm of scan tool MB991502 sound when the input signal enters?**

**YES :** Go to Step 4.

**NO :** Check the input signal circuit from the windshield washer switch. Refer to Inspection Procedure N-15 ([P.54B-260](#)).

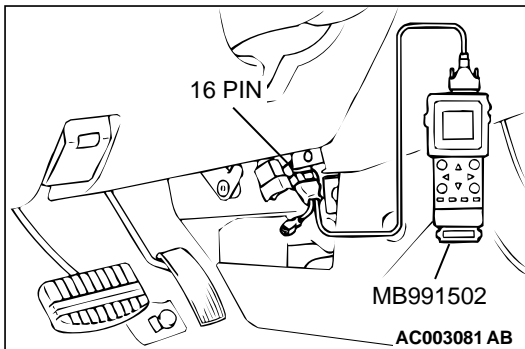

**STEP 3. Check the input signal (by using a voltmeter).**

Check the input signal from the windshield washer switch.

- (1) Use special tool MB991529 to connect a voltmeter between ground terminal 4 or 5 and ETACS-ECU terminal 9 of the data link connector.
- (2) Check that the voltmeter indicator deflects once when the input signal enters.

**Q: Does the voltmeter indicator deflect?**

**YES :** Go to Step 4.

**NO :** Check the input signal circuit from the windshield washer switch. Refer to Inspection Procedure N-15 ([P.54B-260](#)).

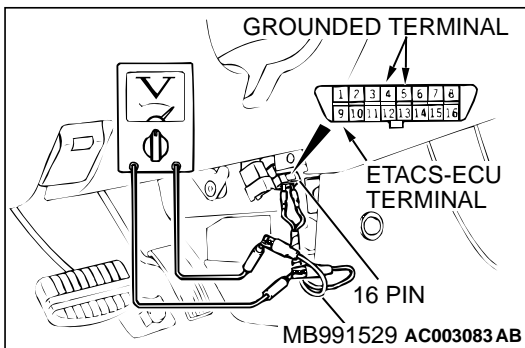

**STEP 4. Check the washer motor.**

- (1) Disconnect the washer motor connector A-33.
- (2) Fill the washer tank with water.
- (3) Check that the water squirts out strongly when battery positive voltage is applied to terminals 1 and 2.

**Q: Is the washer motor in good condition?**

**YES :** Go to Step 5.

**NO :** Replace it. The windshield washer should work normally.

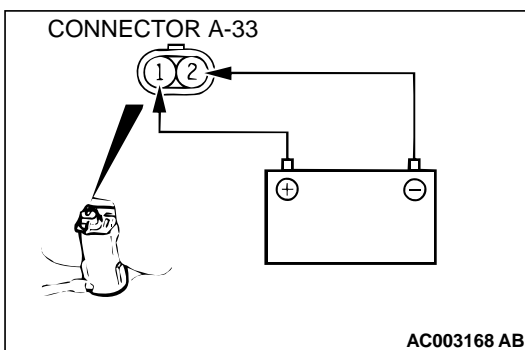

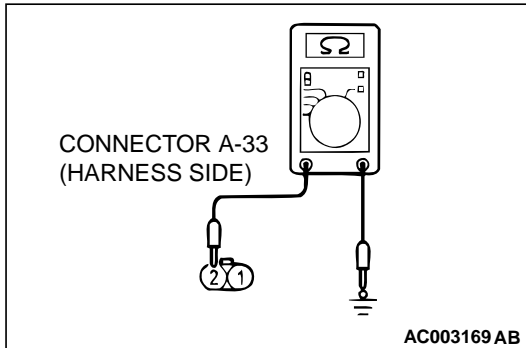

**STEP 5. Check the washer motor ground circuit at the washer motor connector A-33.**

- (1) Disconnect the washer motor connector A-33 and measure at the harness side.
- (2) Measure the resistance between terminal 2 and ground.

**Q: Is the resistance between terminal 2 and ground less than 2 ohm?**

- YES :** Go to Step 8.  
**NO :** Go to Step 6.

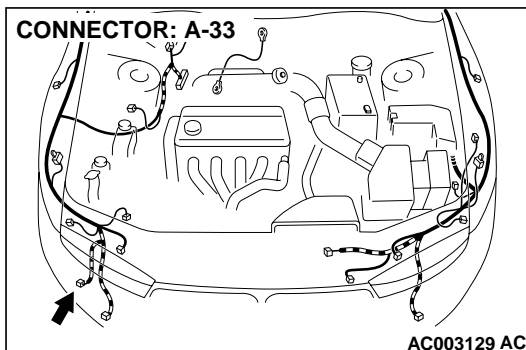

**STEP 6. Check washer motor connector A-33 for damage.**

**Q: Is washer motor connector A-33 in good condition?**

- YES :** Go to Step 7.  
**NO :** Repair or replace it. Refer to GROUP 00E, Harness Connector Inspection [P.00E-2](#) . The windshield washer should work normally.

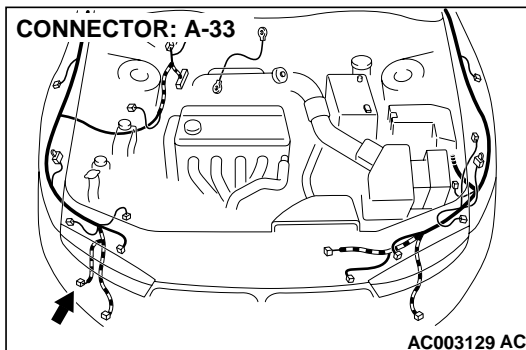

**STEP 7. Check the harness wire between washer motor connector A-33 and ground.**

**Q: Is the harness wire between washer motor connector A-33 and ground in good condition?**

- YES :** There is no action to be taken.  
**NO :** Repair it. The windshield washer should work normally.

**STEP 8. Check washer motor connector A-33 and front-ECU connector A-09X for damage.**

**Q: Are washer motor connector A-33 and front-ECU connector A-09X in good condition?**

**YES :** Go to Step 9.

**NO :** Repair or replace them. Refer to GROUP 00E, Harness Connector Inspection [P.00E-2](#) . The windshield washer should work normally.

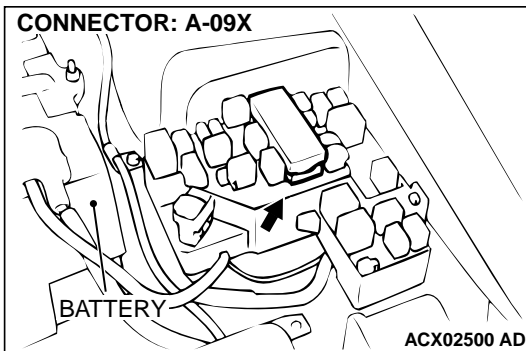
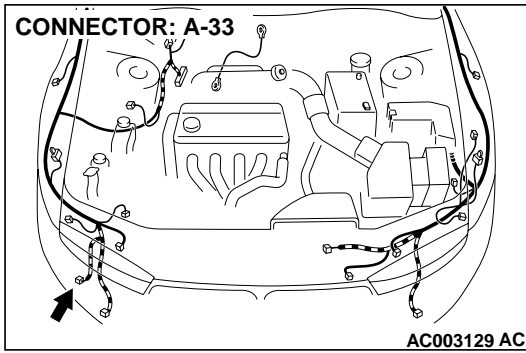

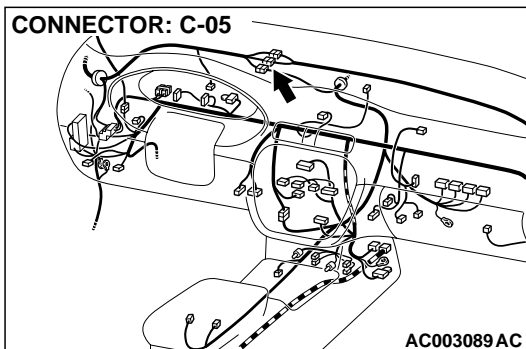
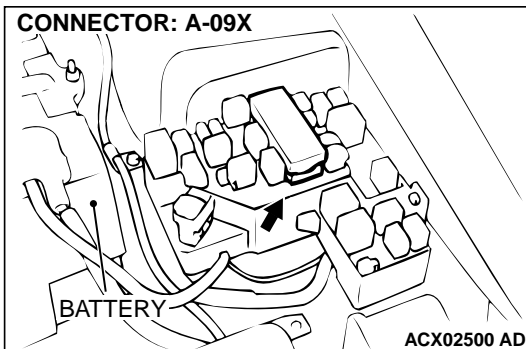
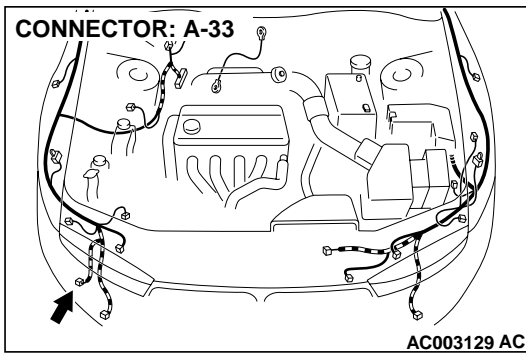

**STEP 9.** Check the harness wires between washer motor connector A-33 and front-ECU connector A-09X.

*NOTE:* After checking intermediate connector C-05, check the wires. If intermediate connector C-05 is damaged, repair or replace it. Refer to GROUP 00E, Harness Connector Inspection P.00E-2 .

**Q:** Are the harness wires between washer motor connector A-33 and front-ECU connector A-09X in good condition?

**YES :** There is no action to be taken.

**NO :** Repair them. The windshield washer should work normally.

**Inspection Procedure G-1: Seat belt warning light: Seat belt warning light does not work normally.**

**Seat Belt Warning Light Circuit**

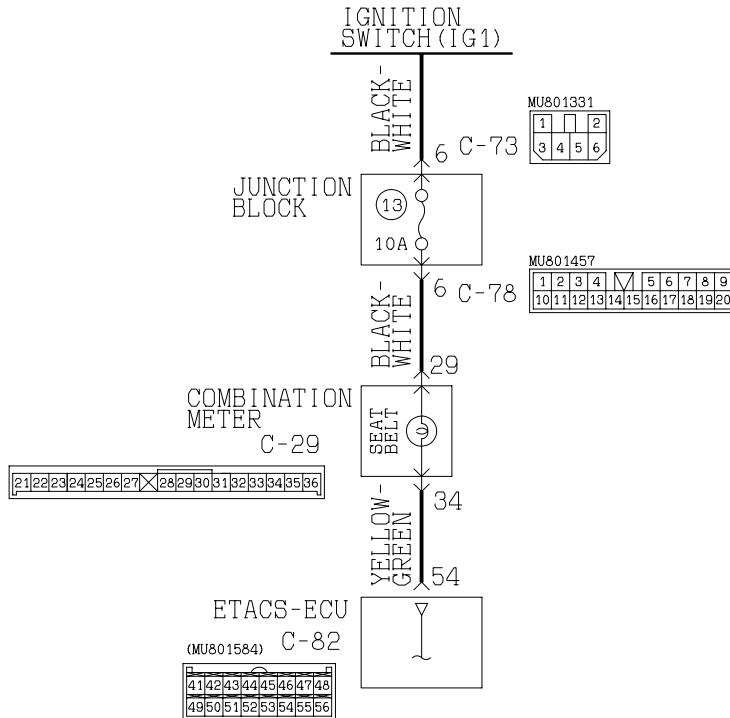

W1S09M10AA  
AC004208

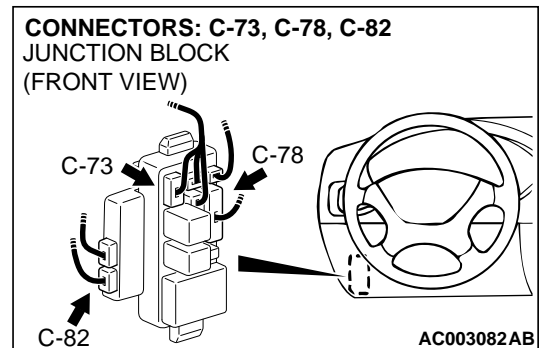
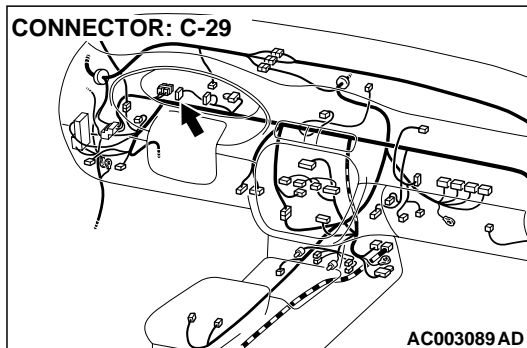

**CIRCUIT OPERATION**

The seat belt warning light illuminates when the driver turns the ignition switch to "ON" position without wearing the seat belt.

**TECHNICAL DESCRIPTION (COMMENT)**

The ETACS-ECU illuminates the seat belt warning light according to the input signals from the following switches:

- Ignition switch (IG1)
- Driver's seat belt switch

If the seat belt warning light does not illuminate, the relevant input signal circuit, the combination meter (seat belt warning light bulb or printed-circuit board) or the ETACS-ECU may be defective.

**TROUBLESHOOTING HINTS**

- Malfunction of the driver's side seat belt switch
- Malfunction of the combination meter (seat belt warning light bulb or printed-circuit board)
- Malfunction of the ETACS-ECU
- Damaged harness wires or connectors

**DIAGNOSIS**

**Required Special Tools:**

- MB991223: Test Harness Set

**TSB Revision**

- MB991502: Scan Tool (MUT-II)
- MB991529: Diagnostic Trouble Code Check Harness

**STEP 1. Check method of the input signal**

**Q: Which is to be used, the scan tool or the voltmeter to check the input signal?**

**Scan tool MB991502 :** Go to Step 2.

**Voltmeter :** Go to Step 3.

**STEP 2. Check the input signal (by using scan tool MB991502).**

Check the input signals from the following switches:

- Ignition switch (IG1)
- Driver's side seat belt switch

**⚠ CAUTION**

To prevent damage to scan tool MB991502, always turn the ignition switch to the "LOCK" (OFF) position before connecting or disconnecting scan tool MB991502.

- (1) Connect scan tool MB991502 to the data link connector.
- (2) Check that the tone alarm of scan tool MB991502 sounds when the input signal enters.

**Q: Does the tone alarm of scan tool MB991502 sound when the input signal enters?**

**YES :** Go to Step 4.

**NO :** Check the relevant input signal circuit. Refer to [P.54B-9](#) .

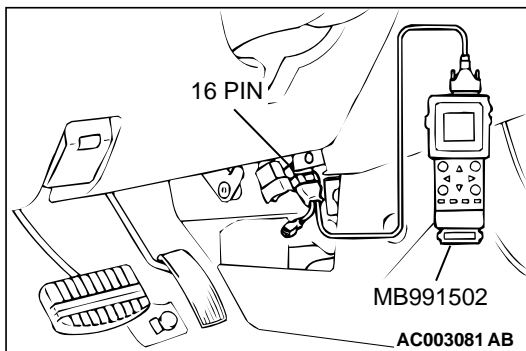
**STEP 3. Check the input signal (by using a voltmeter).**

Check the input signals from the following switches:

- Ignition switch (IG1)
- Driver's side seat belt switch

- (1) Use special tool MB991529 to connect a voltmeter between ground terminal 4 or 5 and ETACS-ECU terminal 9 of the data link connector.
- (2) Check that the voltmeter indicator deflects once when the input signal enters.

**Q: Does the voltmeter indicator deflect?**

**YES :** Go to Step 4.

**NO :** Check the relevant input signal circuit. Refer to [P.54B-9](#) .

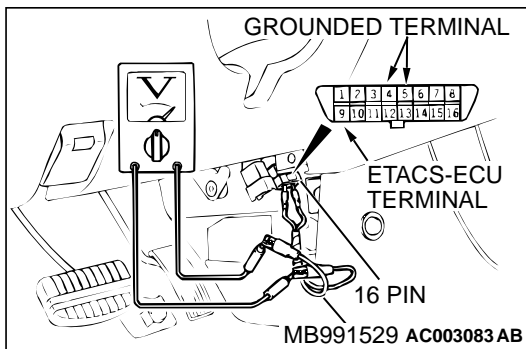



**STEP 4. Check the seat belt warning light circuit at the ETACS-ECU connector C-82.**

- (1) Disconnect the ETACS-ECU connector C-82 and measure at the harness side.
- (2) Turn the ignition switch to the "ON" position.
- (3) Connect terminal 54 to the ground.

**Q: Does the seat belt warning light illuminate?**

**YES :** Replace the ETACS-ECU. The seat belt warning light should work normally.

**NO :** Go to Step 5.

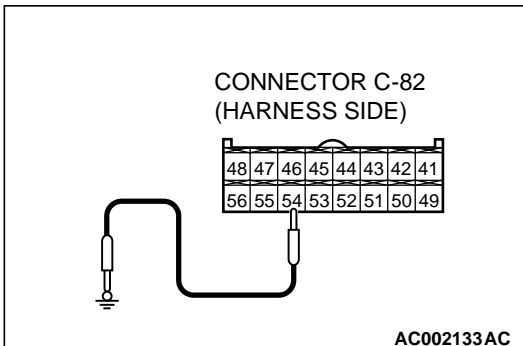

**STEP 5. Check the seat belt warning light bulb.**

**Q: Is the seat belt warning light bulb in good condition?**

**YES :** Go to Step 6.

**NO :** Replace it. The seat belt warning light should work normally.

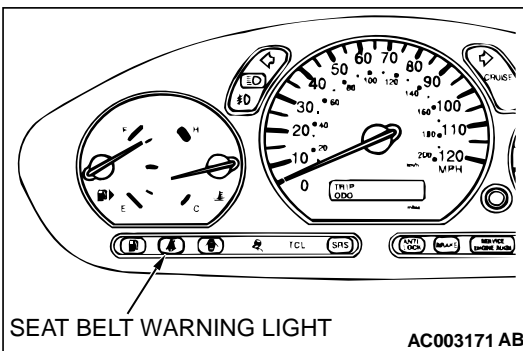

**STEP 6. Check the combination meter (printed-circuit board).**

- (1) Remove the combination meter.
- (2) Remove the seat belt warning light bulb. Then measure the resistance between the bulb terminals.
- (3) Install the bulb to the combination meter, and then measure the resistance between connector C-29 terminal 29 and 34. The resistance reading at this time should be much the same as the resistance measured at Step (2).

**Q: Are the two resistance values extremely different each other?**

**YES :** Repair or replace the combination meter (printed circuit board). The seat belt warning light should work normally.

**NO (much the same) :** Go to Step 7.

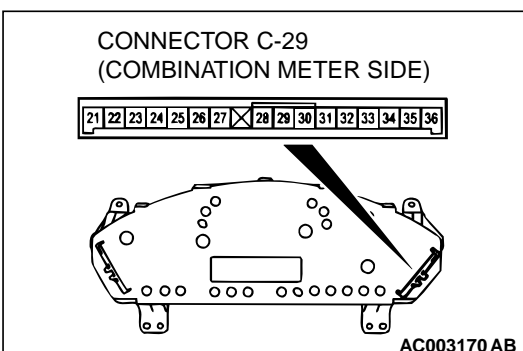

**STEP 7. Check the combination meter power supply circuit at the combination meter connector C-29.**

- (1) Disconnect the combination meter connector C-29 and measure at the harness side.
- (2) Turn the ignition switch to the "ON" position.
- (3) Measure the voltage between terminal 29 and ground.

**Q: Is the voltage approximately 12 volts (battery positive voltage)?**

**YES :** Go to Step 10.

**NO :** Go to Step 8.

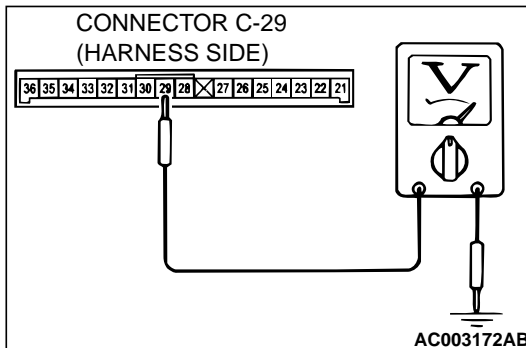
**STEP 8. Check combination meter connector C-29 for damage.**

**Q: Is combination meter connector C-29 in good condition?**

**YES :** Go to Step 9.

**NO :** Repair or replace it. Refer to GROUP 00E, Harness Connector Inspection [P.00E-2](#) . The seat belt warning light should work normally.

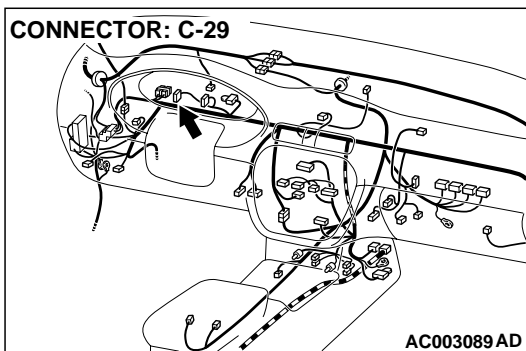

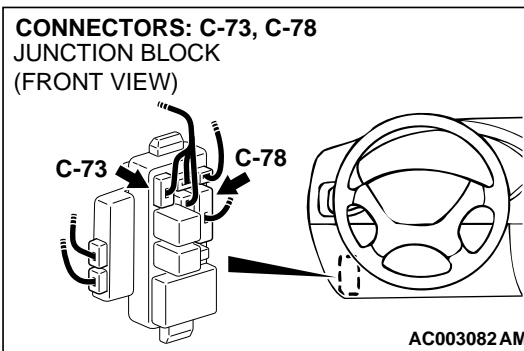
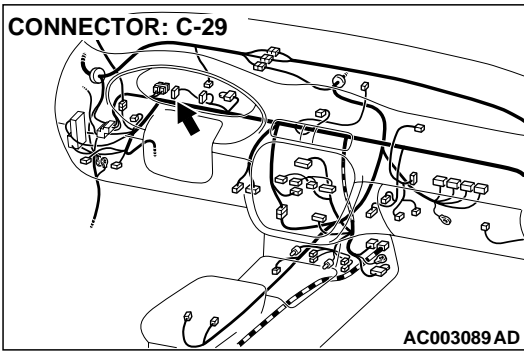

**STEP 9. Check the harness wires between combination meter connector C-29 and ignition switch (IG1).**

**NOTE:** After checking junction block connectors C-73 and C-78, check the wires. If junction block connectors C-73 and C-78 are damaged, repair or replace them. Refer to GROUP 00E, Harness Connector Inspection [P.00E-2](#).

**Q: Are the harness wires between combination meter connector C-29 and ignition switch (IG1) in good condition?**

**YES :** There is no action to be taken.

**NO :** Repair or replace them. The seat belt warning light should work normally.

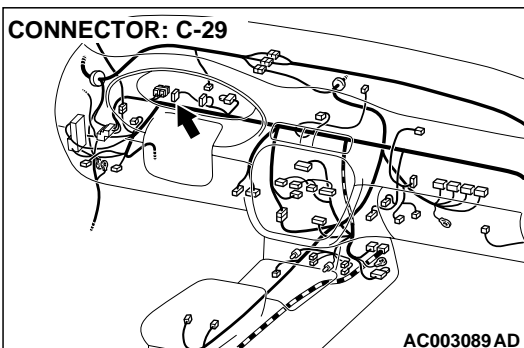

**STEP 10. Check combination meter connector C-29 and ETACS-ECU connector C-82 for damage.**

**Q: Are combination meter connector C-29 and ETACS-ECU connector C-82 in good condition?**

**YES :** Go to Step 11.

**NO :** Repair or replace them. Refer to GROUP 00E, Harness Connector Inspection [P.00E-2](#). The seat belt warning light should work normally.

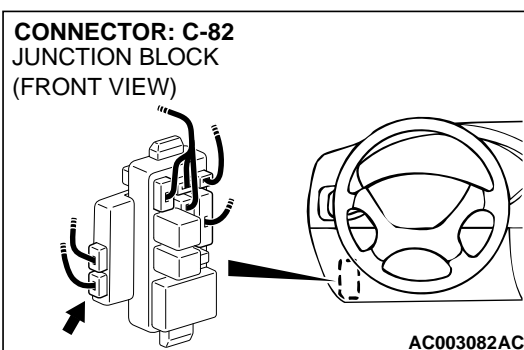

**STEP 11. Check the harness wire between combination meter connector C-29 and ETACS-ECU connector C-82.**

**Q: Is the harness wire between combination meter connector C-29 and ETACS-ECU connector C-82 in good condition?**

**YES :** There is no action to be taken.

**NO :** Repair it. The seat belt warning light should work normally.

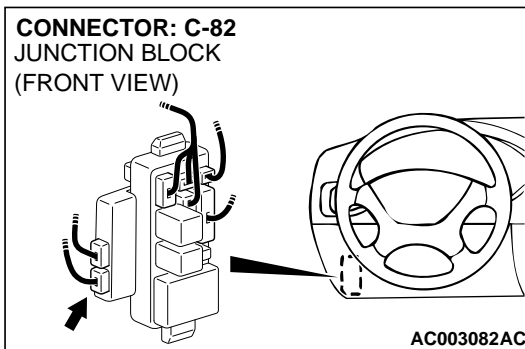
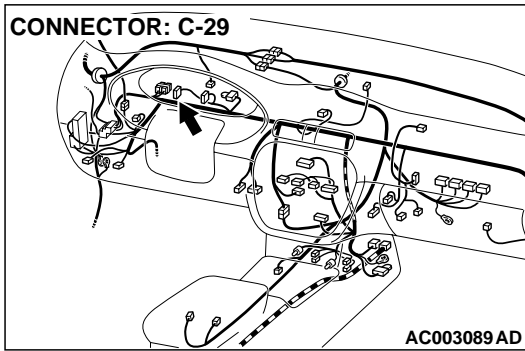

Inspection Procedure H-1: Ignition key hole illumination light : Ignition key hole illumination light does not work normally.

Ignition Key Hole Illumination Light Circuit

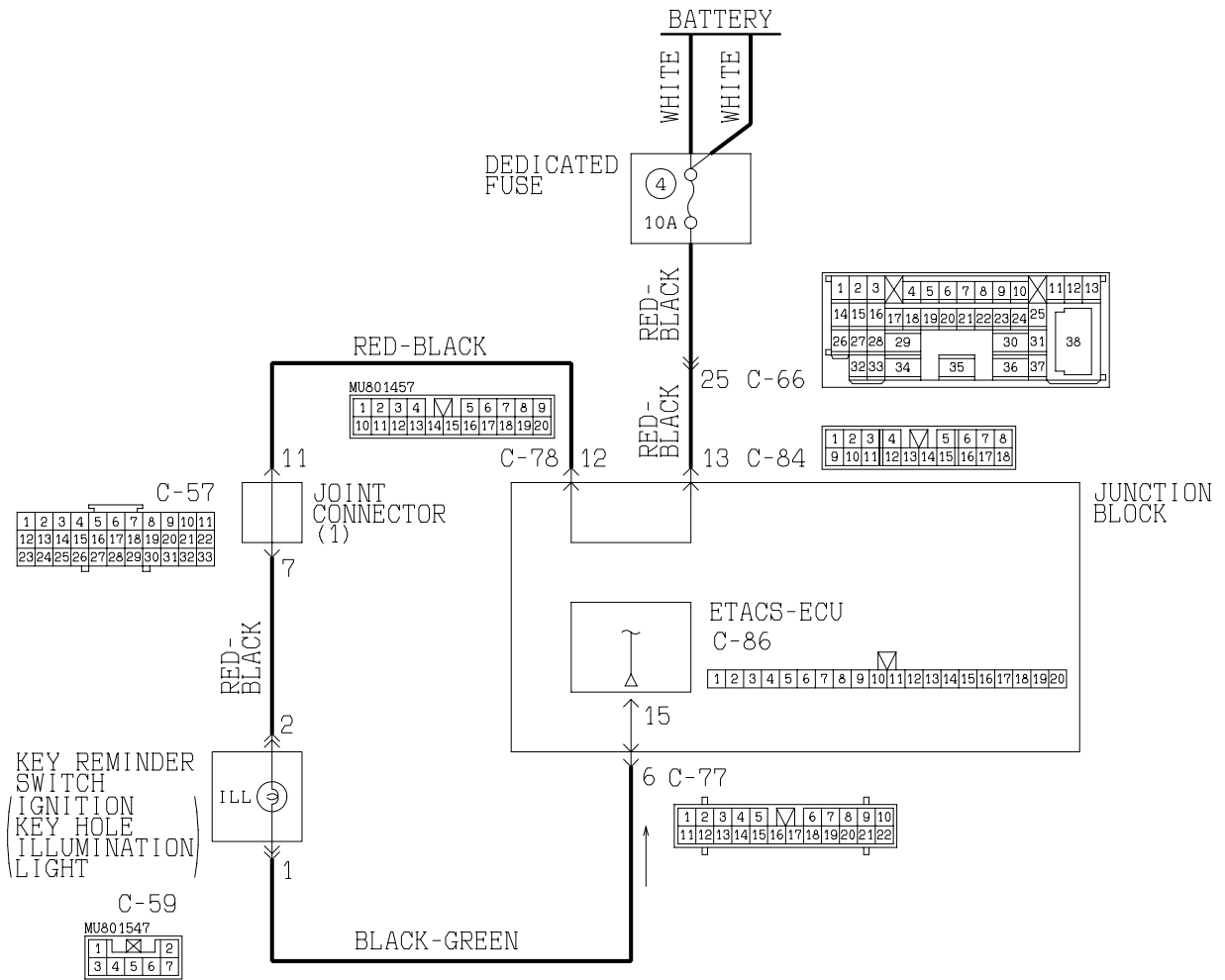

W1S09M11AA

AC004209

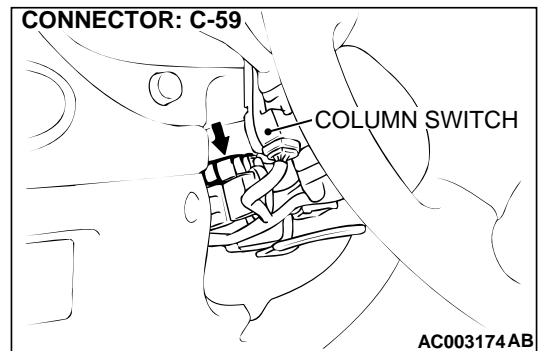
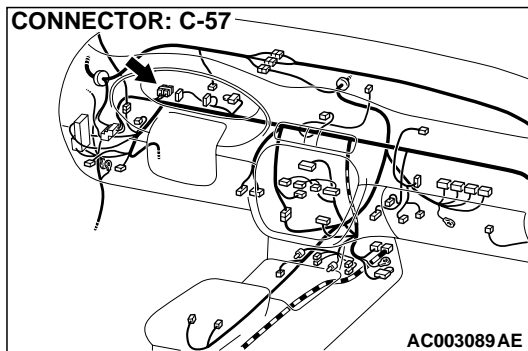

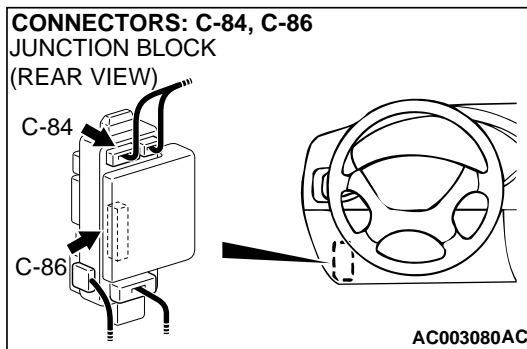
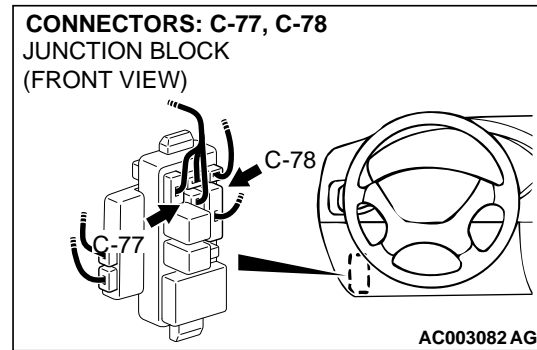
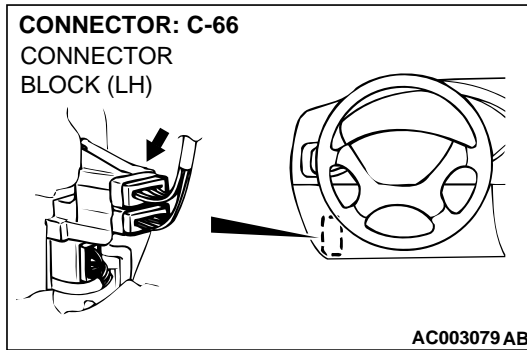

### CIRCUIT OPERATION

The ETACS-ECU illuminates the ignition key hole illumination light when the ignition switch is turned to "LOCK" (OFF) or "ACC" position and the driver's door is opened. The ignition key hole illumination light goes off 30 seconds after closing the driver's door. Also, the ignition key hole illumination light illuminates for 30 seconds after removing the ignition key.

### TECHNICAL DESCRIPTION (COMMENT)

The ETACS-ECU illuminates the ignition key hole illumination light according to the input signals from the following switches:

- Ignition switch (IG1)

- Key reminder switch
- Driver's door switch

If the ignition key hole illumination light does not illuminate, the relevant input signal circuit, the key reminder switch (Ignition key hole illumination light bulb) or the ETACS-ECU may be defective.

### TROUBLESHOOTING HINTS

- Malfunction of the driver's door switch
- Malfunction of the key reminder switch (Key reminder switch or ignition key hole illumination light bulb)
- Malfunction of the ETACS-ECU
- Damaged harness wires or connectors

### DIAGNOSIS

#### Required Special Tools:

- MB991223: Test Harness Set
- MB991502: Scan Tool (MUT-II)
- MB991529: Diagnostic Trouble Code Check Harness

#### STEP 1. Check method of the input signal

**Q: Which is to be used, the scan tool or the voltmeter to check the input signal?**

**Scan tool MB991502 :** Go to Step 2.

**Voltmeter :** Go to Step 3.

**STEP 2. Check the input signal (by using scan tool MB991502).**

Check the input signals from the following switches:

- Ignition switch (IG1)
- Key reminder switch
- Driver's side seat belt switch

**⚠ CAUTION**

To prevent damage to scan tool MB991502, always turn the ignition switch to the "LOCK" (OFF) position before connecting or disconnecting scan tool MB991502.

- (1) Connect scan tool MB991502 to the data link connector.
- (2) Check that the tone alarm of scan tool MB991502 sounds when the input signal enters.

**Q: Does the tone alarm of scan tool MB991502 sound when the input signal enters?**

**YES :** Go to Step 4.

**NO :** Check the relevant input signal circuit. Refer to [P.54B-9](#).

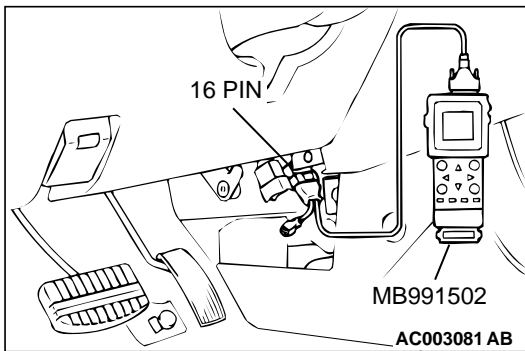

**STEP 3. Check the input signal (by using a voltmeter).**

Check the input signals from the following switches:

- Ignition switch (IG1)
- Key reminder switch
- Driver's side seat belt switch

- (1) Use special tool MB991529 to connect a voltmeter between ground terminal 4 or 5 and ETACS-ECU terminal 9 of the data link connector.
- (2) Check that the voltmeter indicator deflects once when the input signal enters.

**Q: Does the voltmeter indicator deflect?**

**YES :** Go to Step 4.

**NO :** Check the relevant input signal circuit. Refer to [P.54B-9](#).

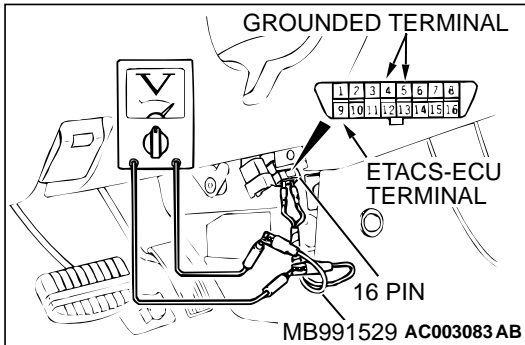

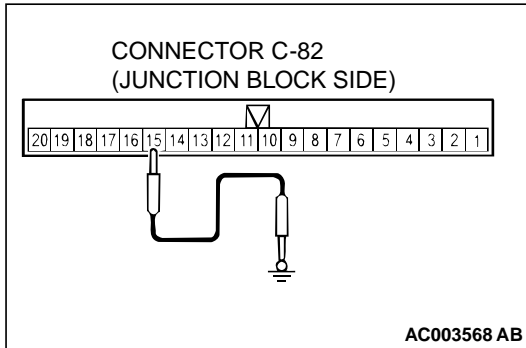

**STEP 4. Check the seat belt warning light circuit at the ETACS-ECU connector C-82.**

Disconnect the ETACS-ECU connector C-82 and measure at the harness side.

(1) Connect terminal 15 to the ground.

**Q: Does the seat belt warning light illuminate?**

**YES** : Replace the ETACS-ECU. The ignition hole illumination light should work normally.

**NO** : Go to Step 5.

**STEP 5. Check the ignition hole illumination light bulb.**

**Q: Is the ignition hole illumination light bulb in good condition?**

**YES** : Go to Step 6.

**NO** : Replace it. The ignition hole illumination light should work normally.

**STEP 6. Check the key reminder switch (ignition key hole illumination).**

(1) Disconnect the key reminder switch connector C-59.

(2) Remove the ignition key hole illumination light bulb. Then measure the resistance between the bulb terminals.

(3) Install the bulb to the key reminder switch, and then measure the resistance between connector C-59 terminal 1 and 2. The resistance reading at this time should be much the same as the resistance measured at Step (2).

**Q: Are the two resistance values extremely different each other?**

**YES** : Repair or replace the key reminder switch. The ignition key hole illumination light should work normally.

**NO (much the same)** : Go to Step 7.

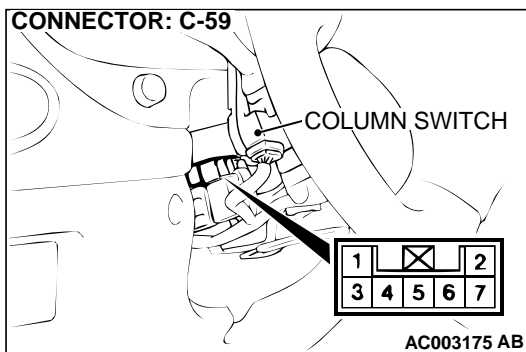



**STEP 7. Check the key reminder switch (ignition key hole illumination light) power supply circuit at the key reminder switch connector C-59.**

- (1) Disconnect the key reminder switch connector C-59 and measure at the harness side.
- (2) Measure the voltage between terminal 2 and ground.

**Q: Is the voltage approximately 12 volts (battery positive voltage)?**

**YES :** Go to Step 10.

**NO :** Go to Step 8.

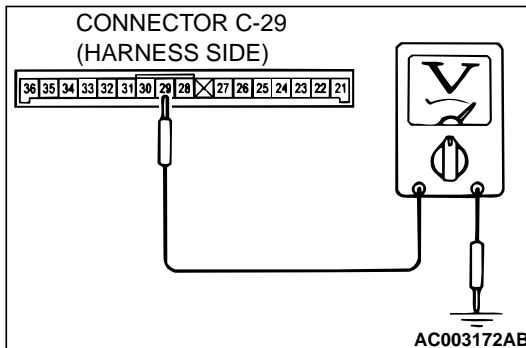

**STEP 8. Check the key reminder switch connector C-59 for damage.**

**Q: Is key reminder switch connector C-59 in good condition?**

**YES :** Go to Step 9.

**NO :** Repair or replace it. Refer to GROUP 00E, Harness Connector Inspection [P.00E-2](#). The ignition key hole illumination light should work normally.

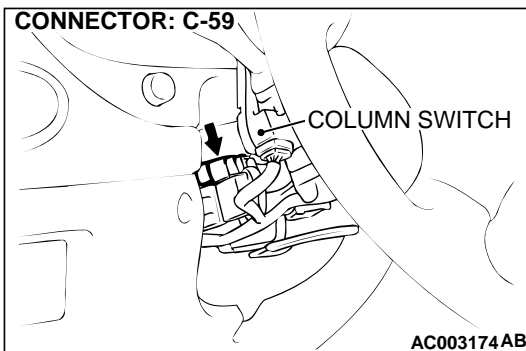

**STEP 9. Check the harness wires between key reminder switch connector C-59 and battery.**

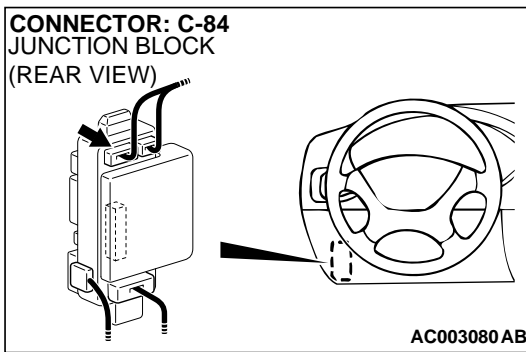
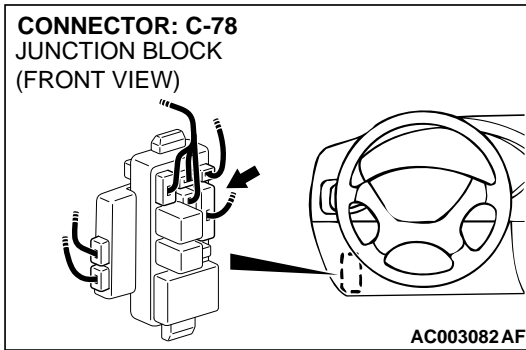
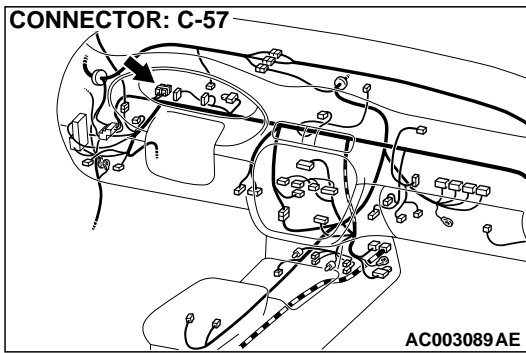
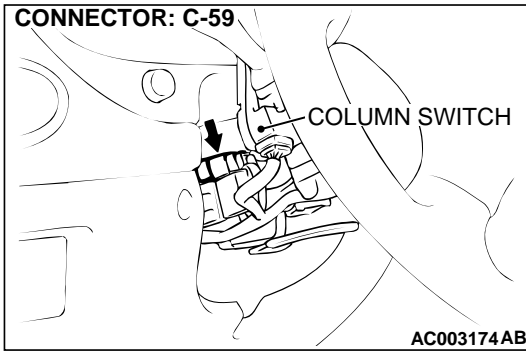

**CONNECTOR: C-66**  
CONNECTOR  
BLOCK (LH)

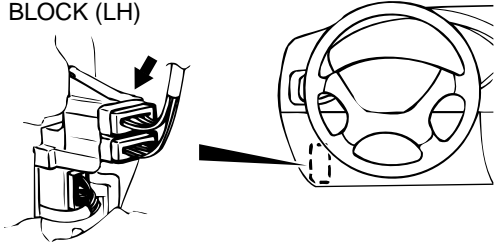

AC003079 AB

*NOTE: After checking joint connector C-57, junction block connectors C-78 and C-84 and intermediate connector C-66, check the wires. If joint connector C-57, junction block connectors C-78 and C-84 and intermediate connector C-66, are damaged, repair or replace them. Refer to GROUP 00E, Harness Connector Inspection [P.00E-2](#).*

**Q: Are the harness wires between key reminder switch connector C-59 and battery in good condition?**

**YES :** There is no action to be taken.

**NO :** Repair or replace them. The ignition key hole illumination light should work normally.

**CONNECTOR: C-59**

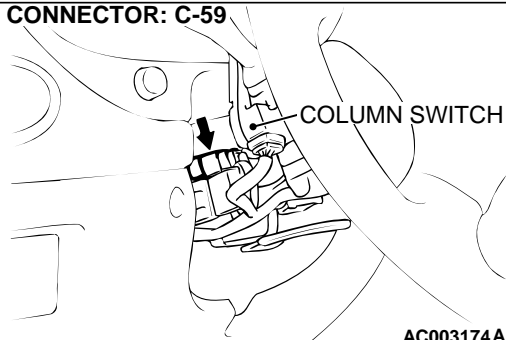

AC003174 AB

**STEP 10. Check key reminder switch connector C-59 and ETACS-ECU connector C-86 for damage.**

**Q: Are key reminder switch connector C-59 and ETACS-ECU connector C-86 in good condition?**

**YES :** Go to Step 11.

**NO :** Repair or replace them. Refer to GROUP 00E, Harness Connector Inspection [P.00E-2](#) . The ignition key hole illumination light should work normally.

**CONNECTOR: C-86**  
JUNCTION BLOCK  
(REAR VIEW)

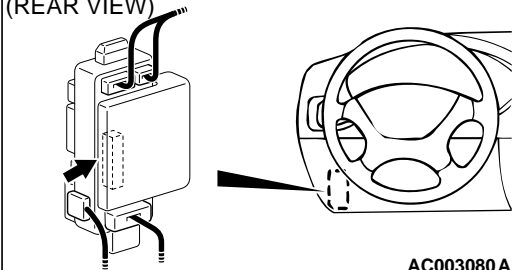

AC003080 AD

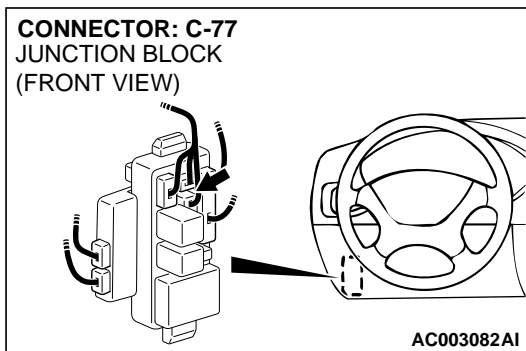
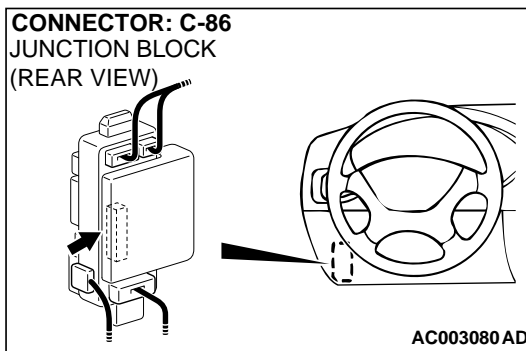
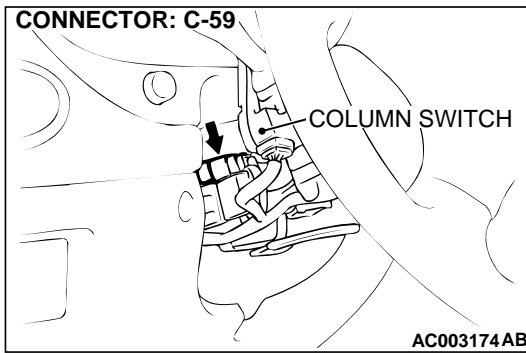

**STEP 11. Check the harness wire between key reminder switch connector C-59 and ETACS-ECU connector C-86.**  
*NOTE: After checking junction block connectors C-77, check the wires. If junction block connectors C-77, is damaged, repair or replace them. Refer to GROUP 00E, Harness Connector Inspection P.00E-2 .*

**Q: Is the harness wire between key reminder switch connector C-59 and ETACS-ECU connector C-86 in good condition?**

**YES :** There is no action to be taken.

**NO :** Repair it. The ignition key hole illumination light should work normally.

**Inspection Procedure I-1: Headlight, taillight: Taillights do not illuminate.**

**Taillight Relay Drive Circuit**

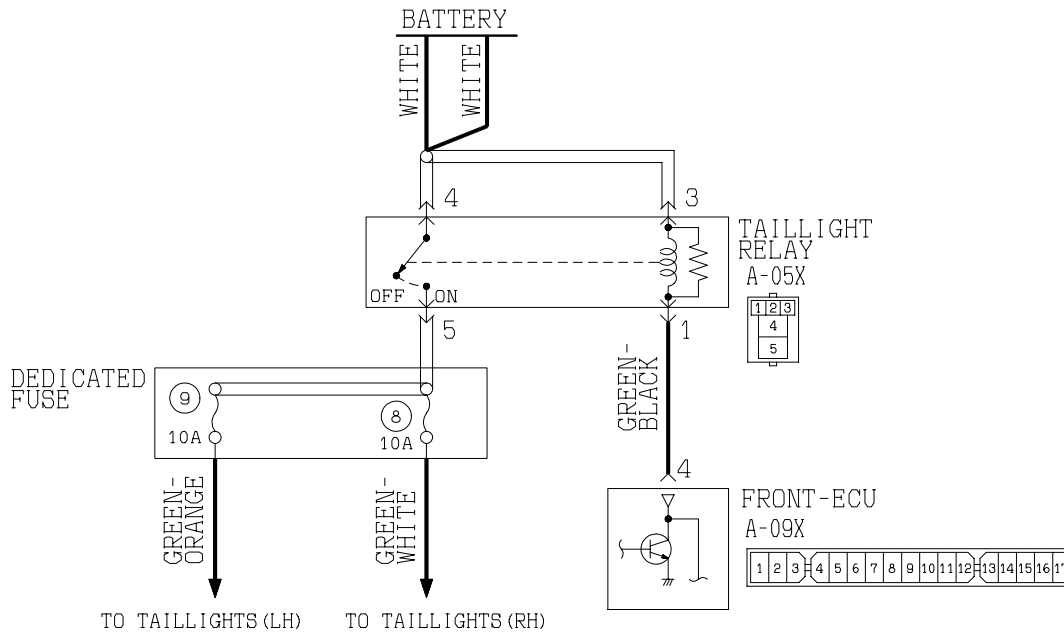

W1S09M12AA  
AC004210

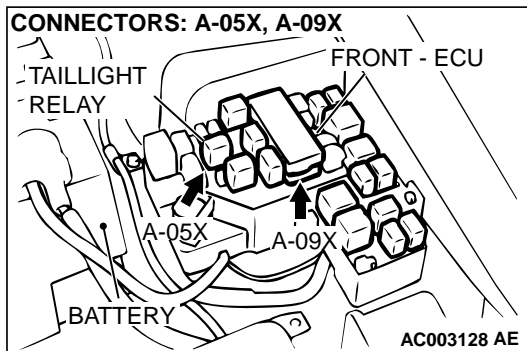

**CIRCUIT OPERATION**

The front-ECU illuminates the taillights if the column switch sends the taillight ON signal to the front-ECU.

**TECHNICAL DESCRIPTION (COMMENT)**

The taillight relay, column switch or the front-ECU may be defective.

*NOTE: If only one light does not illuminate, the harness wire between the light and the taillight relay may be defective or the light bulb may be burned out. In this case, check the circuit by referring to GROUP 90, Taillight, Position Light and License Plate Light P.90-64 .*

**TROUBLESHOOTING HINTS**

- Malfunction of the taillight relay
- Malfunction of the column switch (taillight switch)
- Malfunction of the front-ECU
- Damaged harness wires or connectors

**DIAGNOSIS**

**Required Special Tools:**

- MB991223: Test Harness Set

**TSB Revision**

- MB991502: Scan Tool (MUT-II)
- MB991529: Diagnostic Trouble Code Check Harness

**STEP 1. Check the DTC.**

**Q: Does DTC set when the ignition switch is turned to the "LOCK" (OFF) position?**

**YES :** Carry out the troubleshooting by referring to Diagnostic Trouble Code Chart (P.54B-8).

**NO :** Go to Step 2 <when using scan tool MB991502> or 3 <when using a voltmeter>.

**STEP 2. Check the input signal (by using scan tool MB991502).**

Check the input signal from the taillight switch.

**⚠ CAUTION**

To prevent damage to scan tool MB991502, always turn the ignition switch to the "LOCK" (OFF) position before connecting or disconnecting scan tool MB991502.

- (1) Connect scan tool MB991502 to the data link connector.
- (2) Check that the tone alarm of scan tool MB991502 sounds when the input signal enters.

**Q: Does the tone alarm of scan tool MB991502 sound when the input signal enters?**

**YES :** Go to Step 4.

**NO :** Check the taillight switch input signal circuit. Refer to Inspection Procedure N-14 (P.54B-258).

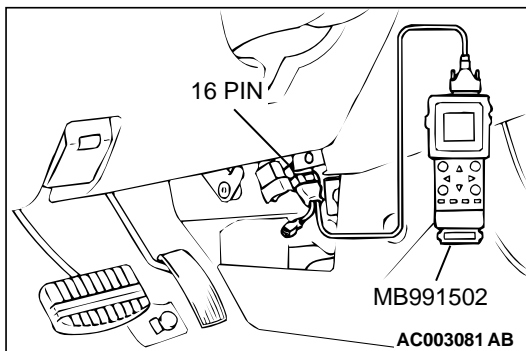
**STEP 3. Check the input signal (by using a voltmeter).**

Check the input signal from the taillight switch.

- (1) Use special tool MB991529 to connect a voltmeter between ground terminal 4 or 5 and ETACS-ECU terminal 9 of the data link connector.
- (2) Check that the voltmeter indicator deflects once when the input signal enters.

**Q: Does the voltmeter indicator deflect?**

**YES :** Go to Step 4.

**NO :** Check the taillight switch input signal circuit. Refer to Inspection Procedure N-14 (P.54B-258).

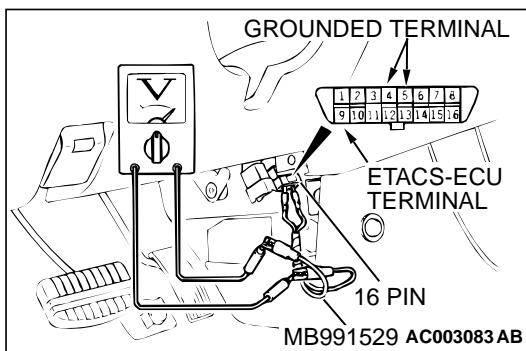

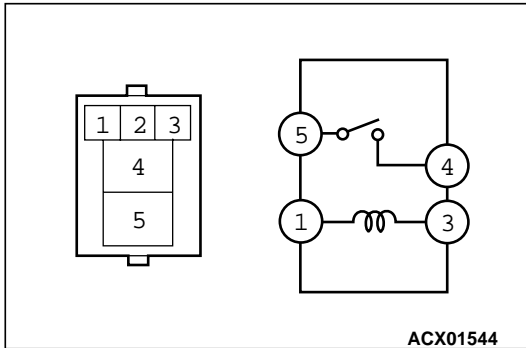

**STEP 4. Check the taillight relay.**

BATTERY VOLTAGE	TESTER CONNECTION	SPECIFIED CONDITION
Not applied	1 – 3	Continuity
1 – Battery (-) terminal, 3 – Battery (+) terminal	4 – 5	Continuity

**Q: Is the taillight relay in good condition?**

**YES :** Go to Step 5.

**NO :** Replace it. The taillights should illuminate normally.

**STEP 5. Check the taillight relay power supply circuit at the taillight relay connector A-05X.**

(1) Disconnect the taillight relay connector A-05X and measure at the relay box side.

(2) Measure the voltages between terminal 3, 4 and ground.

**Q: Are the voltages approximately 12 volts (battery positive voltage)?**

**YES :** Go to Step 8.

**NO :** Go to Step 6.

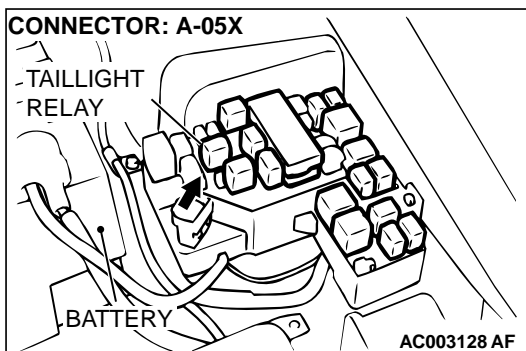
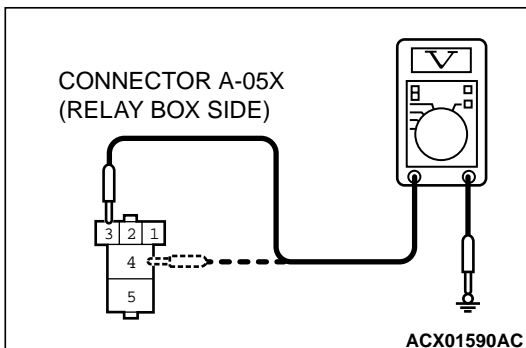

**STEP 6. Check taillight relay connector A-05X for damage.**

**Q: Is taillight relay connector A-05X in good condition?**

**YES :** Go to Step 7.

**NO :** Repair or replace it. Refer to GROUP 00E, Harness Connector Inspection [P.00E-2](#) . The taillights should illuminate normally.

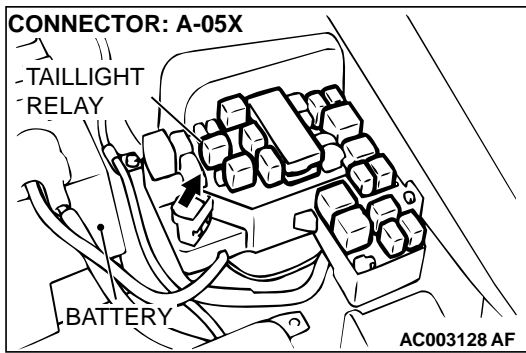

**STEP 7. Check the harness wire between taillight relay connector A-05X and battery.**

**Q: Is the harness wire between taillight relay connector A-05X and battery in good condition?**

**YES :** There is no action to be taken.

**NO :** Repair it. The taillights should illuminate normally.

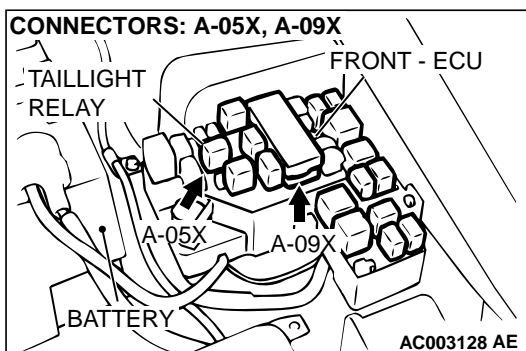

**STEP 8. Check taillight relay connector A-05X and front-ECU connector A-09X for damage.**

**Q: Are taillight relay connector A-05X and front-ECU connector A-09X in good condition?**

**YES :** Go to Step 9.

**NO :** Repair or replace them. Refer to GROUP 00E, Harness Connector Inspection [P.00E-2](#) . The taillights should illuminate normally.

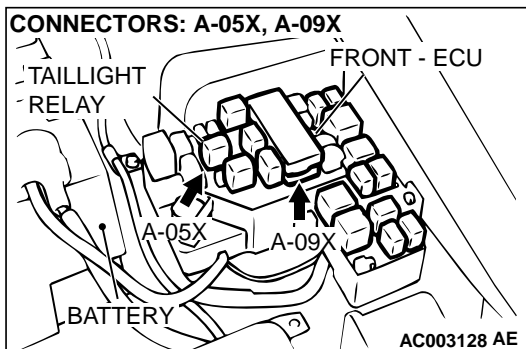

**STEP 9. Check the harness wire between taillight relay connector A-05X and front-ECU connector A-09X.**

**Q: Is the harness wire between taillight relay connector A-05X and front-ECU connector A-09X in good condition?**

**YES :** Replace the front-ECU. The taillights should illuminate normally.

**NO :** Repair it. The taillights should illuminate normally.



**Inspection Procedure I-2: Headlight, taillight: Headlights (low-beam) do not illuminate.**

**Headlight Relay (low) Drive Circuit**

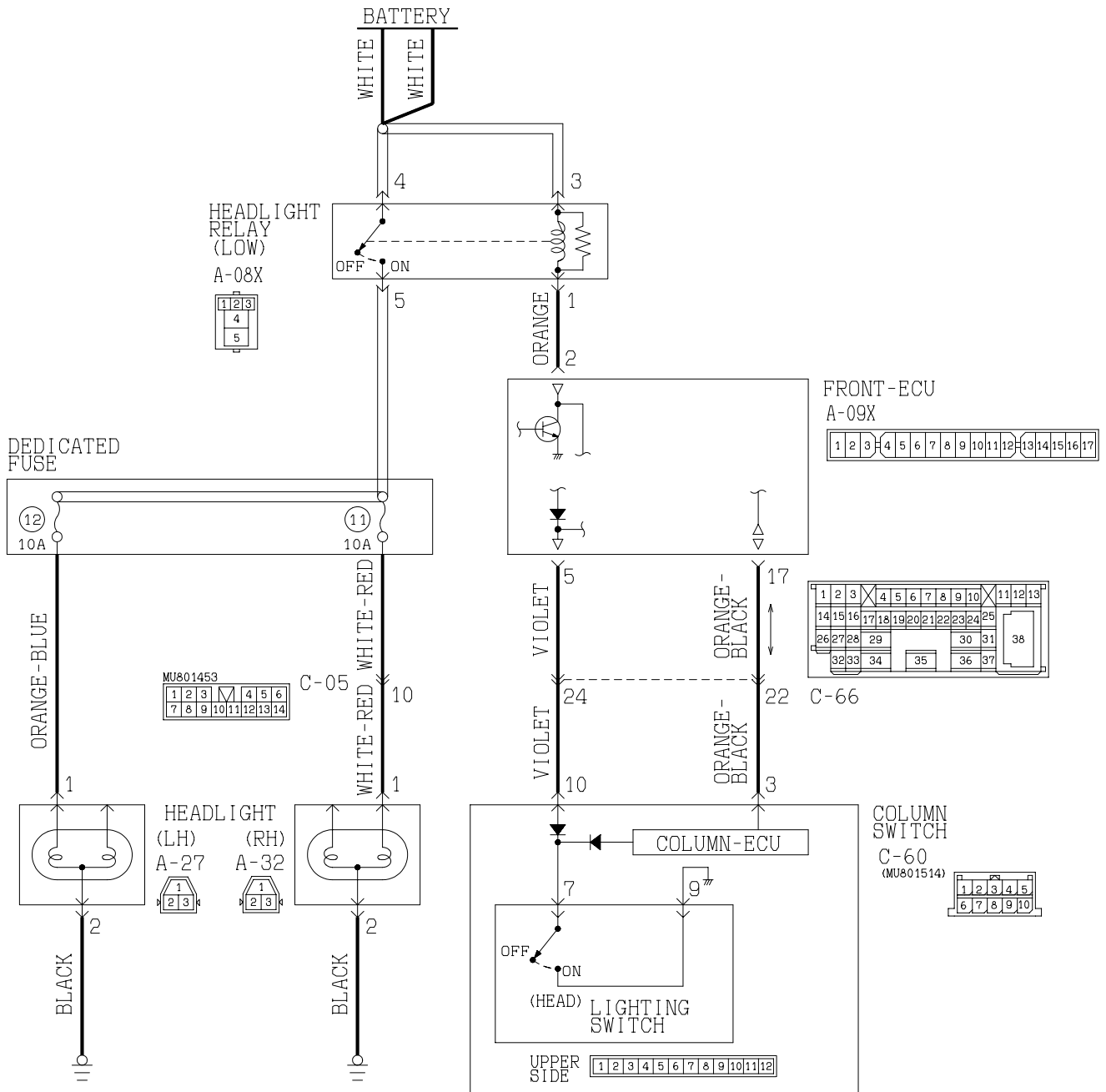

W1S09M13AA  
AC004211

**TSB Revision**

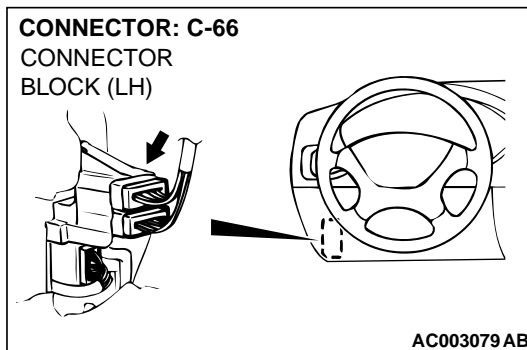
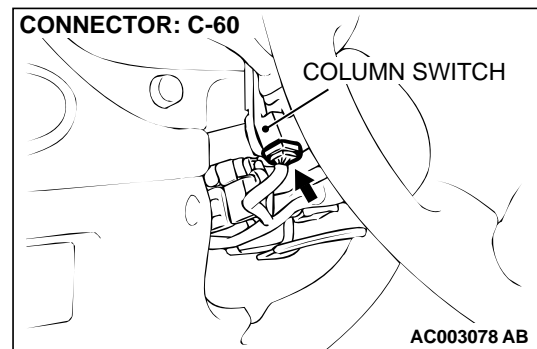
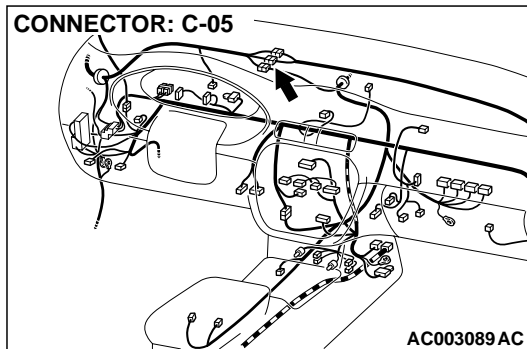
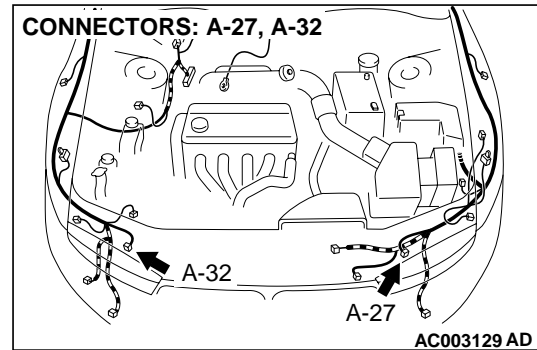
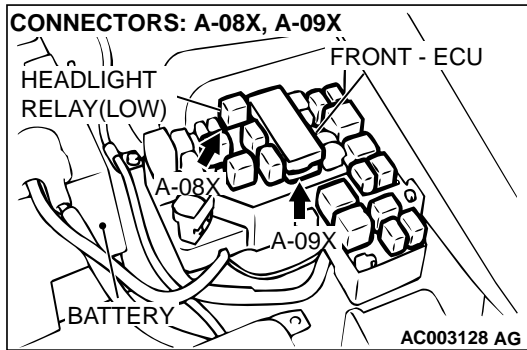

### CIRCUIT OPERATION

- If the headlight switch signal from the column switch turns on, the front-ECU makes the headlights illuminate. Whenever the headlights illuminate, the low-beam lights illuminate due to the headlight dimmer switch automatic resetting function.
- If the SWS communication line is defective, the low-beam headlights will illuminate by using other signal line (headlight back-up circuit).

### TECHNICAL DESCRIPTION (COMMENT)

The headlight relay (low), column switch or the front-ECU may be defective.

*NOTE: If only one of the headlights does not illuminate, the light bulb may be burned out or the harness wires between the light and the headlight relay (low) may be defective. In this case, check the circuit by referring to GROUP 90, Headlight P.90-60.*

### TROUBLESHOOTING HINTS

- Malfunction of the headlight relay (low)
- Malfunction of the column switch (turn-signal light and lighting switch)
- Malfunction of the front-ECU
- Damaged harness wires or connectors

### DIAGNOSIS

#### Required Special Tools:

- MB991223: Test Harness Set
- MB991502: Scan Tool (MUT-II)
- MB991529: Diagnostic Trouble Code Check Harness

**STEP 1. Check the DTC.**

**Q: Does the DTC set when the ignition switch is turned to the "LOCK" (OFF) position?**

**YES :** Carry out the troubleshooting by referring to Diagnostic Trouble Code Chart (P.54B-8 ).

**NO :** Go to Step 2 <when using scan tool MB991502> or 3 <when using a voltmeter>.

**STEP 2. Check the input signal (by using scan tool MB991502).**

Check the input signal from the headlight switch.

**⚠ CAUTION**

**To prevent damage to scan tool MB991502, always turn the ignition switch to the "LOCK" (OFF) position before connecting or disconnecting scan tool MB991502.**

- (1) Connect scan tool MB991502 to the data link connector.
- (2) Check that the tone alarm of scan tool MB991502 sounds when the input signal enters.

**Q: Does the tone alarm of scan tool MB991502 sound when the input signal enters?**

**YES :** Go to Step 4.

**NO :** Check the headlight switch input circuit. Refer to Inspection Procedure O-15 (P.54B-266 ).

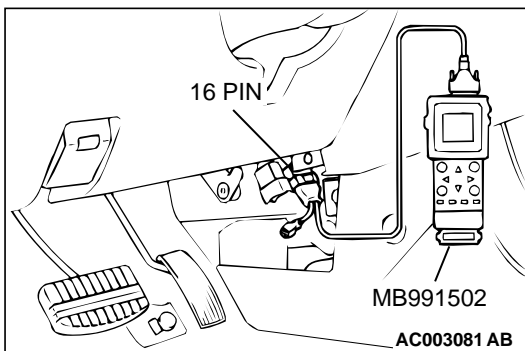

**STEP 3. Check the input signal (by using a voltmeter).**

Check the input signal from the headlight switch.

- (1) Use special tool MB991529 to connect a voltmeter between ground terminal 4 or 5 and ETACS-ECU terminal 9 of the data link connector.
- (2) Check that the voltmeter indicator deflects once when the input signal enters.

**Q: Does the voltmeter indicator deflect?**

**YES :** Go to Step 4.

**NO :** Check the headlight switch input circuit. Refer to Inspection Procedure O-15 (P.54B-266 ).

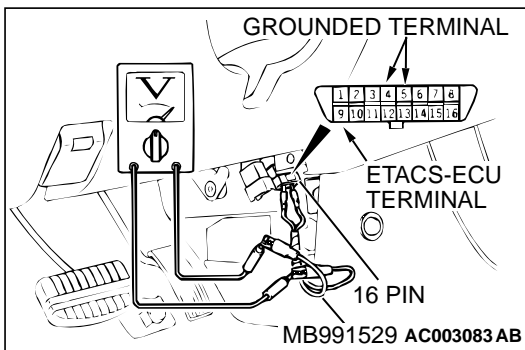

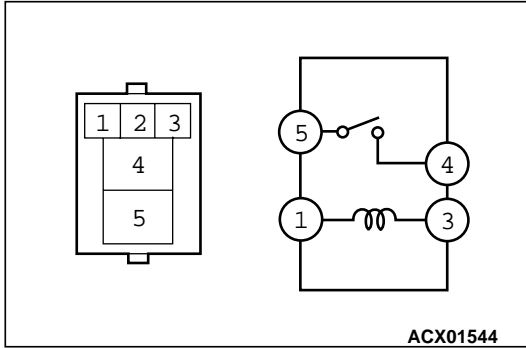

**STEP 4. Check the headlight relay (low).**

BATTERY VOLTAGE	TESTER CONNECTION	SPECIFIED CONDITION
Not applied	1 – 3	Continuity
1 – Battery (+) terminal, 3 – Battery (–) terminal	4 – 5	Continuity

**Q: Is the headlight relay (low) in good condition?**

**YES :** Go to Step 5.

**NO :** Replace it. The headlights (low-beam) should illuminate normally.

**STEP 5. Check the headlight relay (low) power supply circuit at the headlight relay (low) connector A-08X.**

- (1) Disconnect the headlight relay (low) connector A-08X and measure at the relay box side.
- (2) Measure the voltages between terminal 3, 4 and ground.

**Q: Are the voltages approximately 12 volts (battery positive voltage)?**

**YES :** Go to Step 8.

**NO :** Go to Step 6.

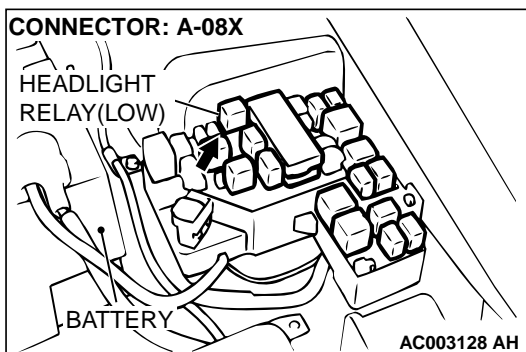
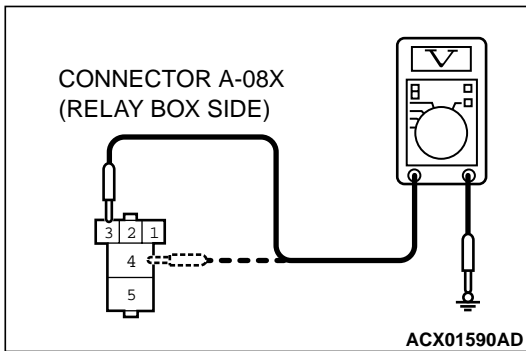

**STEP 6. Check headlight relay (low) connector A-08X for damage.**

**Q: Is headlight relay (low) connector A-08X in good condition?**

**YES :** Go to Step 7.

**NO :** Repair or replace it. Refer to GROUP 00E, Harness Connector Inspection [P.00E-2](#) . The headlight (low-beam) should illuminate normally.

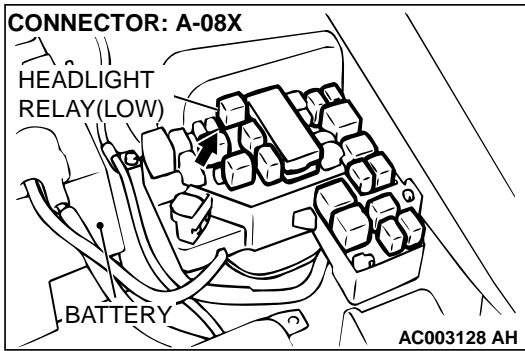

**STEP 7. Check the harness wire between headlight relay (low) connector A-08X and battery.**

**Q: Is the harness wire between headlight relay (low) connector A-08X and battery in good condition?**

**YES :** There is no action to be taken.

**NO :** Repair it. The headlights (low-beam) should illuminate normally.

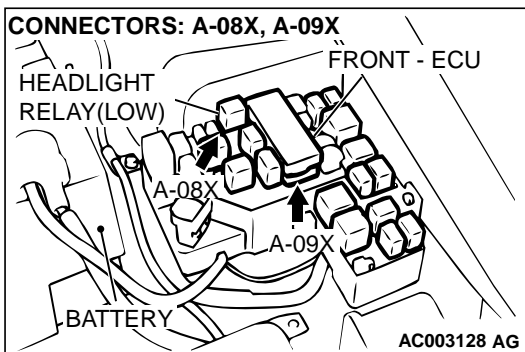

**STEP 8. Check headlight relay (low) connector A-08X and front-ECU connector A-09X for damage.**

**Q: Are headlight relay (low) connector A-08X and front-ECU connector A-09X in good condition?**

**YES :** Go to Step 9.

**NO :** Repair or replace them. Refer to GROUP 00E, Harness Connector Inspection [P.00E-2](#) . The headlights (low-beam) should illuminate normally.

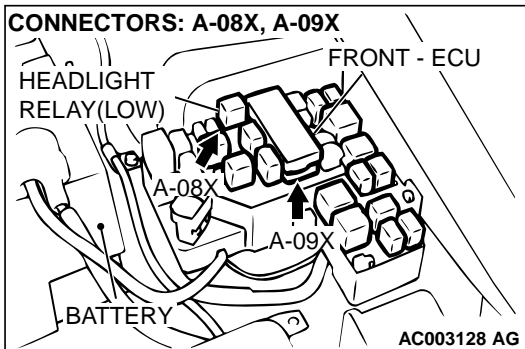

**STEP 9. Check the harness wire between headlight relay (low) connector A-08X and front-ECU connector A-09X.**

**Q: Is the harness wire between headlight relay (low) connector A-08X and front-ECU connector A-09X in good condition?**

**YES :** Go to Step 10.

**NO :** Repair it. The headlights (low-beam) should illuminate normally.

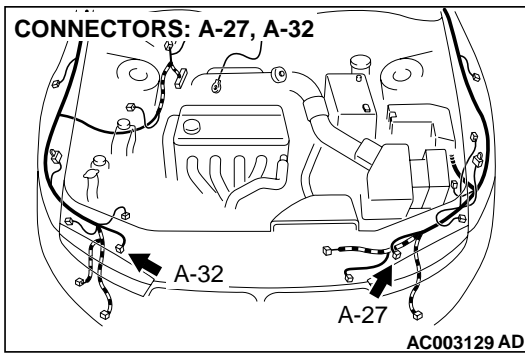

**STEP 10. Check headlight connectors A-27 and A-32 for damage.**

**Q: Are headlight connectors A-27 and A-32 in good condition?**

**YES :** Go to Step 11.

**NO :** Repair or replace it. Refer to GROUP 00E, Harness Connector Inspection [P.00E-2](#) . The headlights (low-beam) should illuminate normally.

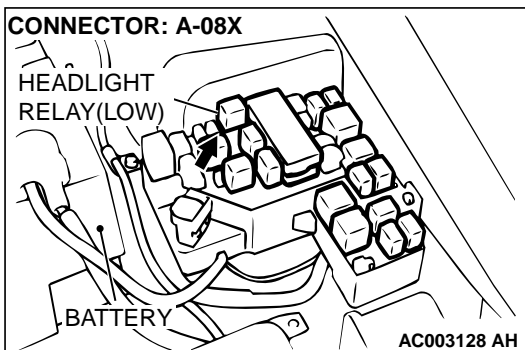

**STEP 11. Check the harness wires between headlight relay (low) connector A-08X and headlight connectors A-27 and A-32.**

**NOTE:** After checking intermediate connector C-05, check the wires. If intermediate connector C-05 is damaged, repair or replace it. Refer to GROUP 00E, Harness Connector Inspection [P.00E-2](#) .

**Q: Are the harness wires between headlight relay (low) connector A-08X and headlight connectors A-27 and A-32 in good condition?**

**YES :** Replace the front-ECU. The headlights (low-beam) should illuminate normally.

**NO :** Repair them. The headlights (low-beam) should illuminate normally.

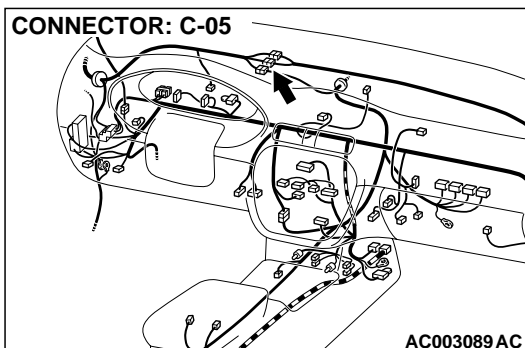
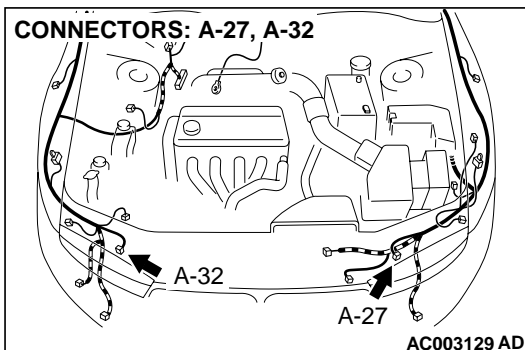

**Inspection Procedure I-3: Headlight, taillight: Headlights (high-beam) do not illuminate.**

**Headlight Relay (high) Drive Circuit**

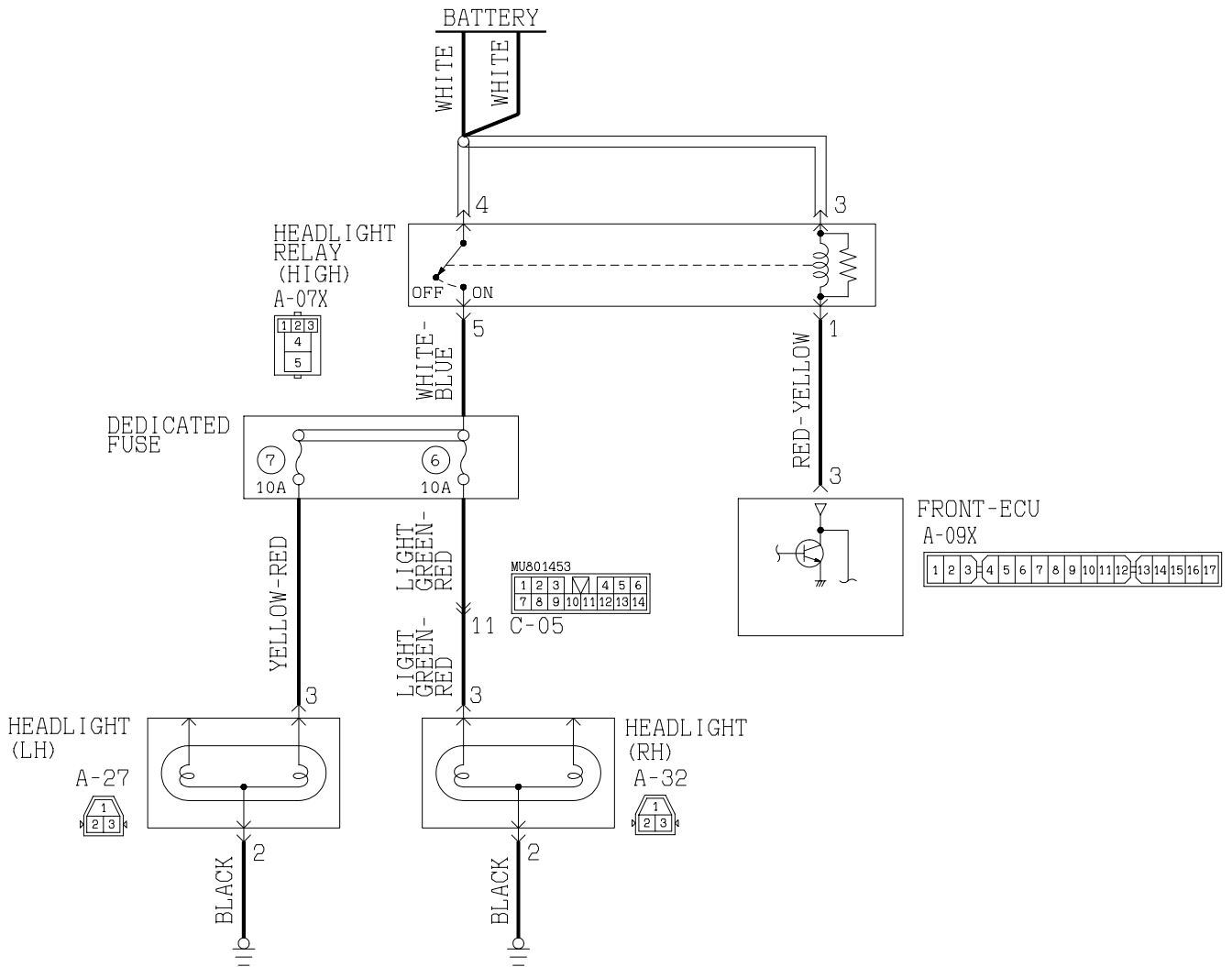

W1S09M14AA  
AC004373

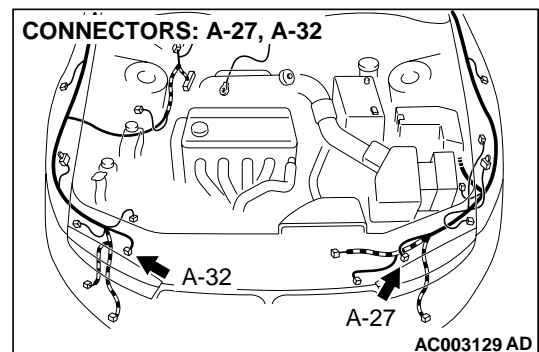
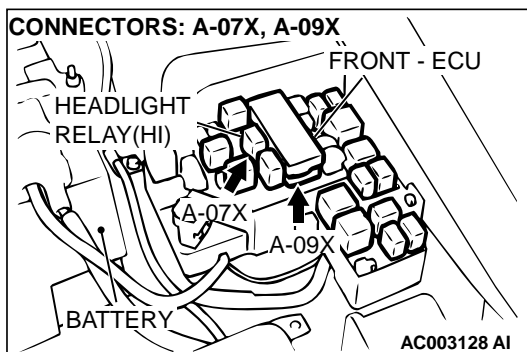

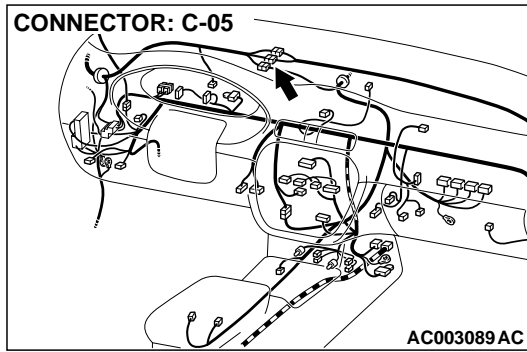
**CIRCUIT OPERATION**

If the column switch sends the dimmer switch ON signal to the front-ECU, the front-ECU switches the headlights from low-beam to high-beam or vice versa.

**TECHNICAL DESCRIPTION (COMMENT)**

The headlight relay (high), column switch or the front-ECU may be defective.

*NOTE: If only one of the headlights does not illuminate, the light bulb may be burned out or the harness wires between the light and the headlight relay (high) may be defective. In this case, check the circuit by referring to GROUP 90, Headlight P.90-60.*

**TROUBLESHOOTING HINTS**

- Malfunction of the headlight relay (high)
- Malfunction of the column switch (turn-signal light and lighting switch)
- Malfunction of the front-ECU
- Damaged harness wires or connectors

**DIAGNOSIS****Required Special Tools:**

- MB991223: Test Harness Set
- MB991502: Scan Tool (MUT-II)
- MB991529: Diagnostic Trouble Code Check Harness

**STEP 1. Check the headlight (low-beam) operation.****Q: Do the headlights (low-beam) illuminate normally?**

**YES** : Go to Step 2 <when using scan tool MB991502> or 3 <when using a voltmeter>.

**NO** : Solve the problem first. Refer to Inspection Procedure I-2 (P.54B-122 ).



**STEP 2. Check the input signal (by using scan tool MB991502).**

Check the input signal from the dimmer switch.

**⚠ CAUTION**

To prevent damage to scan tool MB991502, always turn the ignition switch to the "LOCK" (OFF) position before connecting or disconnecting scan tool MB991502.

- (1) Connect scan tool MB991502 to the data link connector.
- (2) Check that the tone alarm of scan tool MB991502 sounds when the input signal enters.

**Q: Does the tone alarm of scan tool MB991502 sound when the input signal enters?**

**YES :** Go to Step 4.

**NO :** Check the headlight switch input circuit. Refer to Inspection Procedure N-14 (P.54B-258 ).

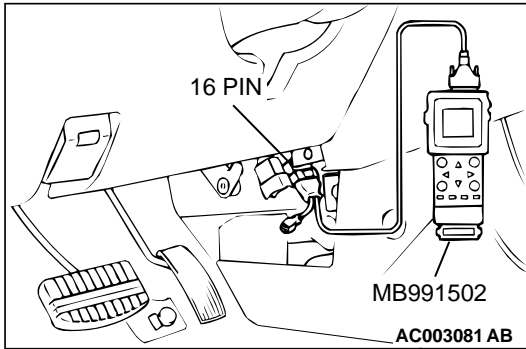

**STEP 3. Check the input signal (by using a voltmeter).**

Check the input signal from the dimmer switch.

- (1) Use special tool MB991529 to connect a voltmeter between ground terminal 4 or 5 and ETACS-ECU terminal 9 of the data link connector.
- (2) Check that the voltmeter indicator deflects once when the input signal enters.

**Q: Does the voltmeter indicator deflect?**

**YES :** Go to Step 4.

**NO :** Check the headlight switch input circuit. Refer to Inspection Procedure N-14 (P.54B-258 ).

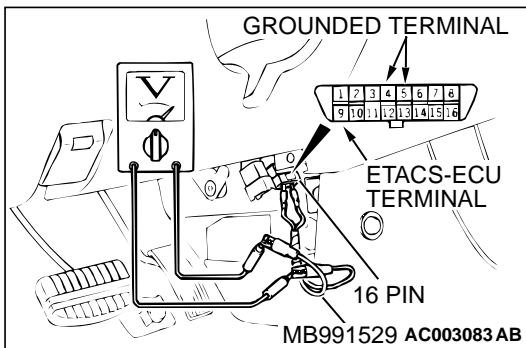

**STEP 4. Check the headlight relay (high).**

BATTERY VOLTAGE	TESTER CONNECTION	SPECIFIED CONDITION
Not applied	1 – 3	Continuity
1 – Battery (+) terminal, 3 – Battery (–) terminal	4 – 5	Continuity

**Q: Is the headlight relay (high) in good condition?**

**YES :** Go to Step 5.

**NO :** Replace it. The headlights (high-beam) should illuminate normally.

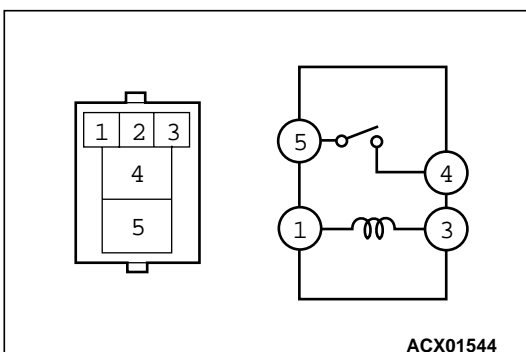

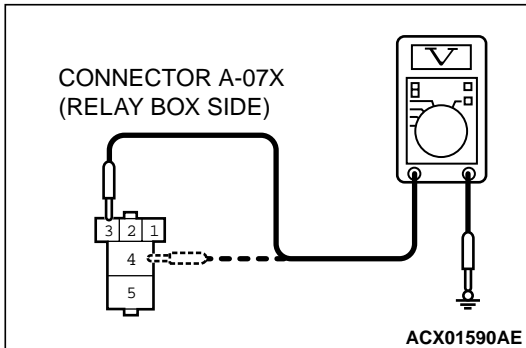

**STEP 5. Check the headlight relay (high) power supply circuit at the headlight relay (high) connector A-07X.**

- (1) Disconnect the headlight relay (high) connector A-07X and measure at the relay box side.
- (2) Measure the voltages between terminal 3, 4 and ground.

**Q: Are the voltages approximately 12 volts (battery positive voltage)?**

**YES :** Go to Step 8.

**NO :** Go to Step 6.

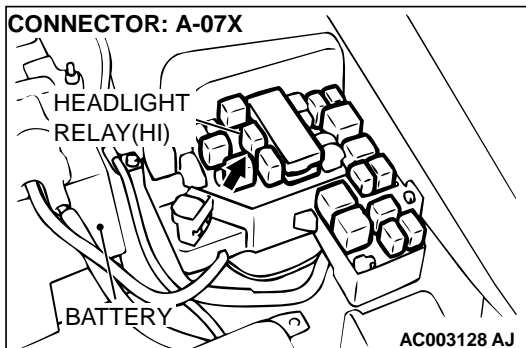

**STEP 6. Check headlight relay (high) connector A-07X for damage.**

**Q: Is headlight relay (high) connector A-07X in good condition?**

**YES :** Go to Step 7.

**NO :** Repair or replace it. Refer to GROUP 00E, Harness Connector Inspection [P.00E-2](#) . The headlight (high-beam) should illuminate normally.

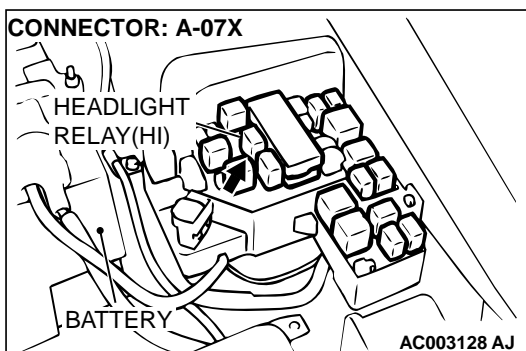

**STEP 7. Check the harness wire between headlight relay (high) connector A-07X and battery.**

**Q: Is the harness wire between headlight relay (high) connector A-07X and battery in good condition?**

**YES :** There is no action to be taken.

**NO :** Repair it. The headlights (high-beam) should illuminate normally.

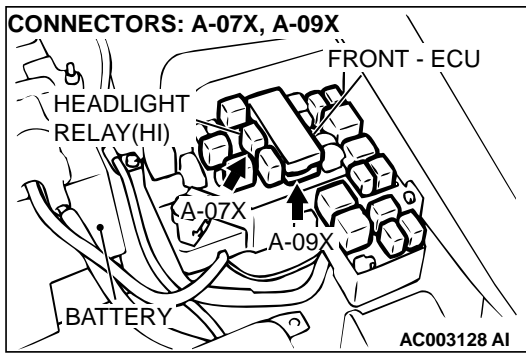

**STEP 8. Check headlight relay (high) connector A-07X and front-ECU connector A-09X for damage.**

**Q: Are headlight relay (high) connector A-07X and front-ECU connector A-09X in good condition?**

**YES :** Go to Step 9.

**NO :** Repair or replace them. Refer to GROUP 00E, Harness Connector Inspection [P.00E-2](#) . The headlights (high-beam) should illuminate normally.

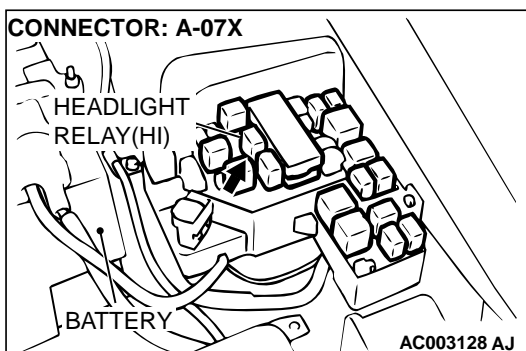

**STEP 9. Check the harness wire between headlight relay (high) connector A-07X and front-ECU connector A-09X.**

**Q: Is the harness wire between headlight relay (high) connector A-07X and front-ECU connector A-09X in good condition?**

**YES :** Go to Step 10.

**NO :** Repair it. The headlights (high-beam) should illuminate normally.

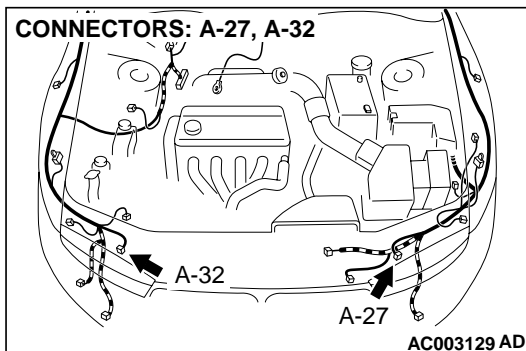

**STEP 10. Check headlight connectors A-27 and A-32 for damage.**

**Q: Are headlight connectors A-27 and A-32 in good condition?**

**YES :** Go to Step 11.

**NO :** Repair or replace it. Refer to GROUP 00E, Harness Connector Inspection [P.00E-2](#) . The headlights (high-beam) should illuminate normally.

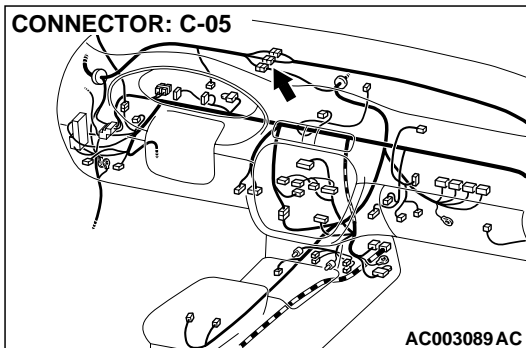
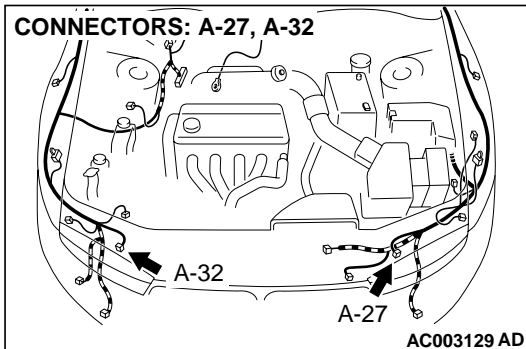
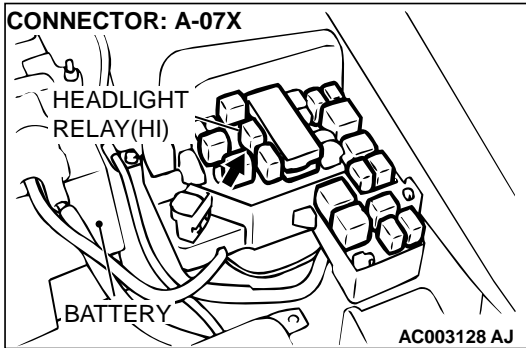

**STEP 11. Check the harness wires between headlight relay (high) connector A-07X and headlight connectors A-27 and A-32.**

*NOTE: After checking intermediate connector C-05, check the wires. If intermediate connector C-05 is damaged, repair or replace it. Refer to GROUP 00E, Harness Connector Inspection P.00E-2 .*

**Q: Are the harness wires between headlight relay (high) connector A-07X and headlight connectors A-27 and A-32 in good condition?**

**YES :** Replace the front-ECU. The headlights (high-beam) should illuminate normally.

**NO :** Repair them. The headlights (high-beam) should illuminate normally.

**Inspection Procedure I-4: Headlight, taillight: Headlights do not illuminate when the passing switch is operated.**

**HEADLIGHTS DO NOT ILLUMINATE WHEN THE PASSING SWITCH IS OPERATE.**

If the column switch or the front-ECU is suspected to be defective.

**TROUBLESHOOTING HINTS**

- Malfunction of the column switch (turn-signal light and lighting switch)
- Malfunction of the front-ECU
- Damaged harness wires or connectors

**DIAGNOSIS**

**Required Special Tools:**

- MB991502: Scan Tool (MUT-II)
- MB991529: Diagnostic Trouble Code Check Harness

**STEP 1. Check the headlight (low-beam and high-beam) operation.**

**Q: Do the headlights (low-beam and high-beam) illuminate normally?**

**YES :** Go to Step 2 <when using scan tool MB991502> or 3 <when using a voltmeter>.

**NO :** Solve the problem first. Refer to [P.54B-9](#).

**STEP 2. Check the input signal (by using scan tool MB991502).**

Check the input signal from the passing switch.

**⚠ CAUTION**

**To prevent damage to scan tool MB991502, always turn the ignition switch to the "LOCK" (OFF) position before connecting or disconnecting scan tool MB991502.**

- (1) Connect scan tool MB991502 to the data link connector.
- (2) Check that the tone alarm of scan tool MB991502 sounds when the input signal enters.

**Q: Does the tone alarm of scan tool MB991502 sound when the input signal enters?**

**YES :** Replace the front-ECU. The passing switch should work normally.

**NO :** Check the passing switch input circuit. Refer to Inspection Procedure N-14 ([P.54B-258](#)).

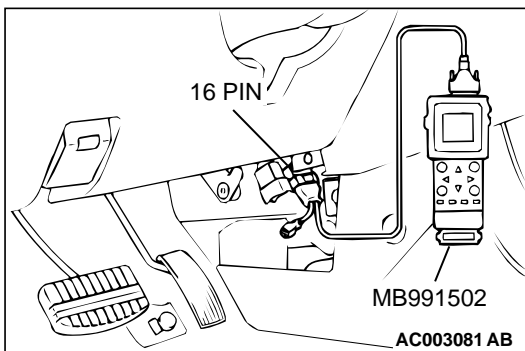

**STEP 3. Check the input signal (by using a voltmeter).**

Check the input signal from the passing switch.

- (1) Use special tool MB991529 to connect a voltmeter between ground terminal 4 or 5 and ETACS-ECU terminal 9 of the data link connector.
- (2) Check that the voltmeter indicator deflects once when the input signal enters.

**Q: Does the voltmeter indicator deflect?**

**YES :** Replace the front-ECU. The passing switch should work normally.

**NO :** Check the passing switch input circuit. Refer to Inspection Procedure N-14 ([P.54B-258](#)).

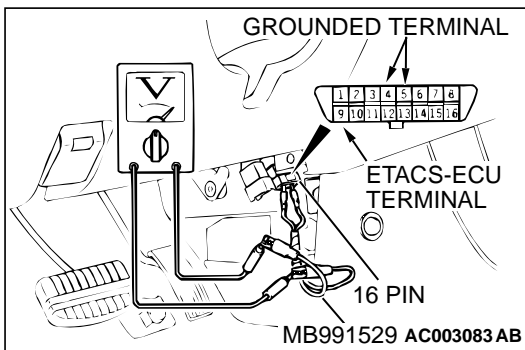

Inspection Procedure I-5: Headlight, taillight: High-beam indicator light does not illuminate.

High-beam Indicator Light Circuit

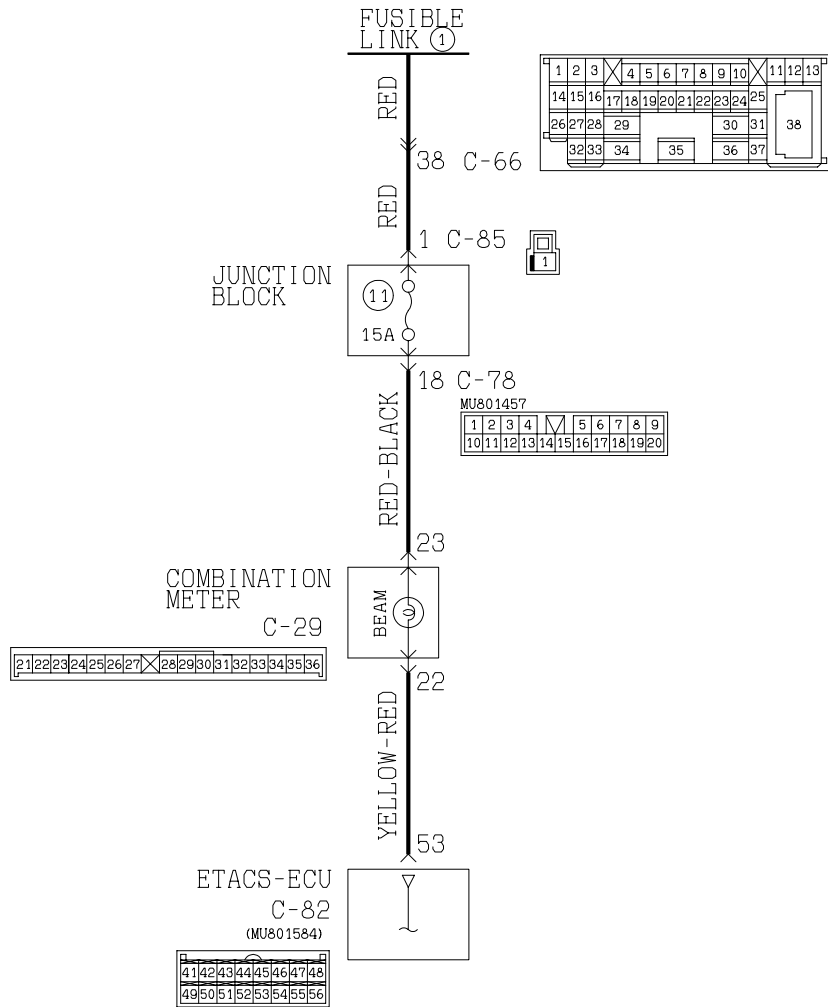

W1809M15AA  
AC004212

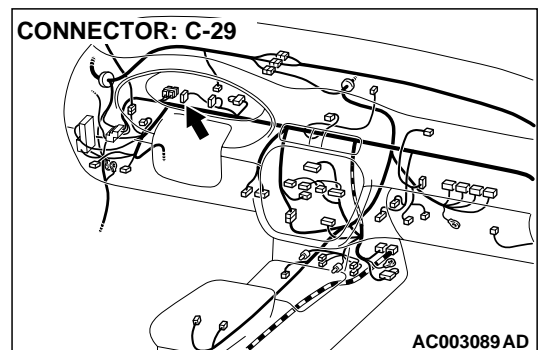
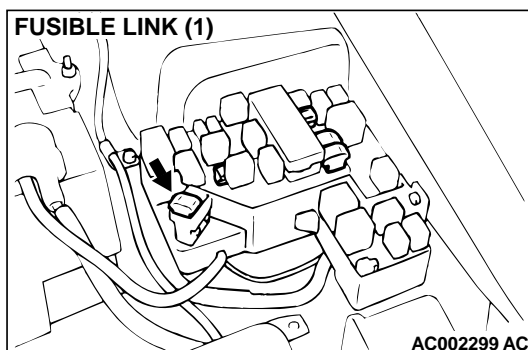

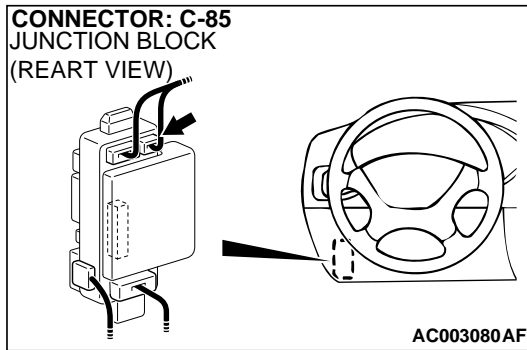
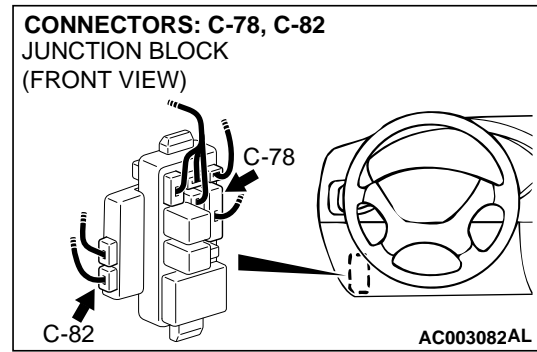
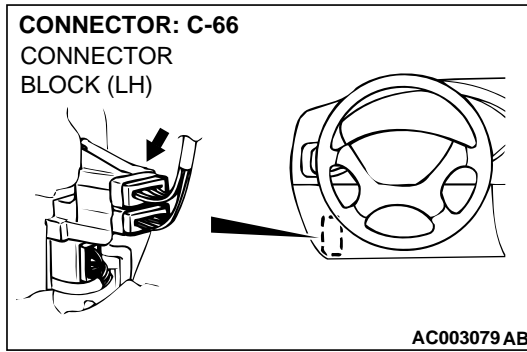

### CIRCUIT OPERATION

When the passing switch is on or the front-ECU is illuminating the headlights (high-beam), the ETACS-ECU illuminates the high-beam indicator light.

### TECHNICAL DESCRIPTION (COMMENT)

If the headlights (high-beam and passing) operate normally, the combination meter (high-beam indicator light bulb or printed-circuit board), the front-ECU or the ETACS-ECU is suspected to be defective.

### TROUBLESHOOTING HINTS

- Malfunction of the combination meter (high-beam indicator light bulb or printed-circuit board)
- Malfunction of the front-ECU
- Malfunction of the ETACS-ECU
- Damaged harness wires or connectors

### DIAGNOSIS

#### Required Special Tool:

- MB991223: Test Harness Set

**STEP 1. Check the headlights (high-beam and passing) operation.**

**Q: Do the headlights (high-beam and passing) illuminate normally?**

**YES :** Go to Step 2.

**NO :** Solve the problem first. Refer to [P.54B-9](#).

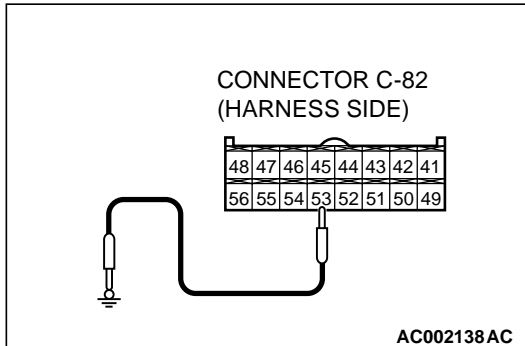

**STEP 2. Check the high-beam indicator light circuit at the ETACS-ECU connector C-82.**

- (1) Disconnect the ETACS-ECU connector C-82 and measure at the harness side.
- (2) Connect terminal 53 to the ground.

**Q: Does the high-beam indicator light illuminate?**

**YES :** Go to Step 10.

**NO :** Go to Step 3.

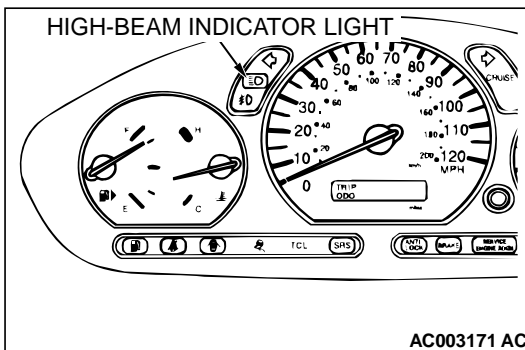

**STEP 3. Check the high-beam indicator light bulb.**

**Q: Is the high-beam indicator light bulb in good condition?**

**YES :** Go to Step 4.

**NO :** Replace it. The high-beam indicator light should work normally.

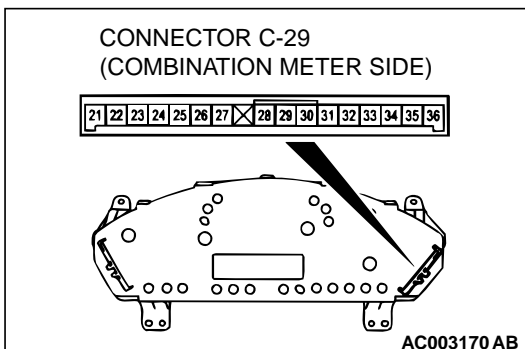

**STEP 4. Check the combination meter (printed-circuit board).**

- (1) Remove the combination meter.
- (2) Remove the high-beam indicator light bulb. Then measure the resistance between the bulb terminals.
- (3) Install the bulb to the combination meter, and then measure the resistance between connector C-29 terminal 22 and 23. The resistance reading at this time should be much the same as the resistance measured at Step (2).

**Q: Are the two resistance values extremely different each other?**

**YES :** Repair or replace the combination meter (printed circuit board). The high-beam indicator light should work normally.

**NO (much the same) :** Go to Step 5.



**STEP 5. Check the combination meter power supply circuit at the combination meter connector C-29.**

- (1) Disconnect the combination meter connector C-29 and measure at the harness side.
- (2) Measure the voltage between terminal 23 and ground.

**Q: Is the voltage approximately 12 volts (battery positive voltage)?**

- YES :** Go to Step 8.  
**NO :** Go to Step 6.

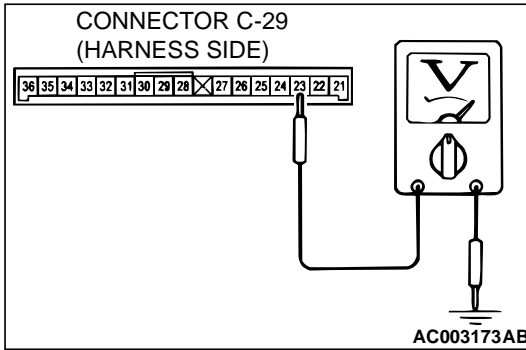

**STEP 6. Check combination meter connector C-29 for damage.**

**Q: Is combination meter connector C-29 in good condition?**

- YES :** Go to Step 7.  
**NO :** Repair or replace it. Refer to GROUP 00E, Harness Connector Inspection [P.00E-2](#) . The high-beam indicator light should work normally.

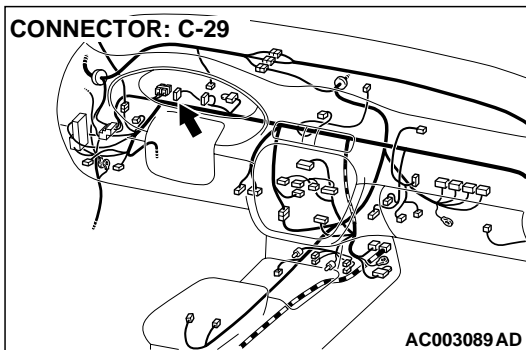

**STEP 7. Check the harness wires between combination meter connector C-29 and fusible link (1).**

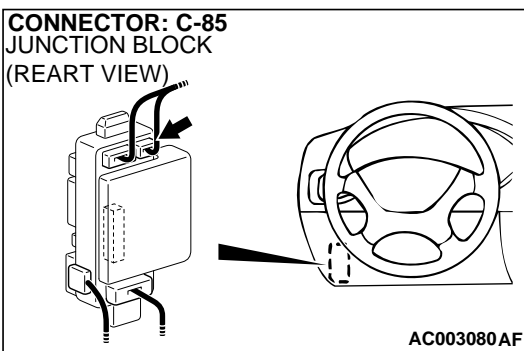
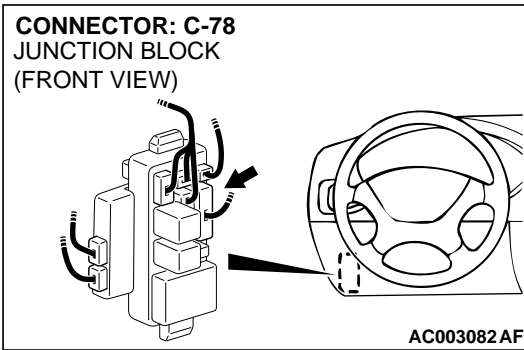
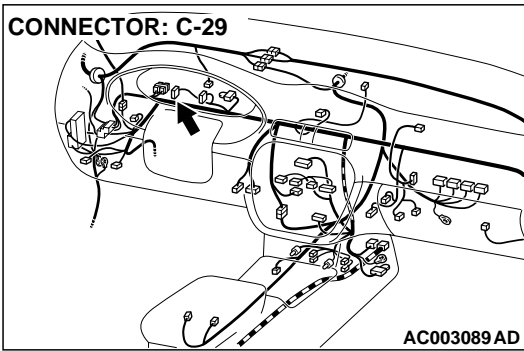
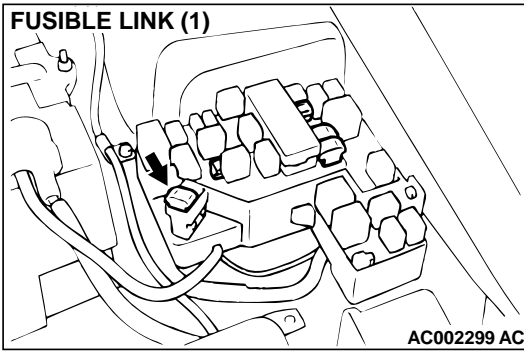

**CONNECTOR: C-66**  
CONNECTOR  
BLOCK (LH)

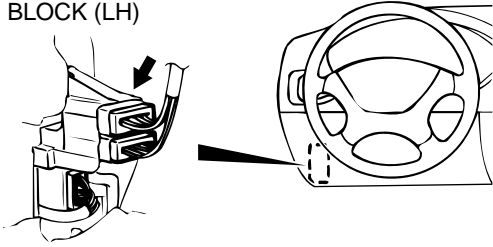

AC003079 AB

*NOTE: After checking junction block connectors C-78 and C-85 and intermediate connector C-66, check the wires. If junction block connectors C-78 and C-85 and intermediate connector C-66 are damaged, repair or replace them. Refer to GROUP 00E, Harness Connector Inspection [P.00E-2](#).*

**Q: Are the harness wires between combination meter connector C-29 and fusible link (1) in good condition?**

**YES :** There is no action to be taken.

**NO :** Repair or replace them. The high-beam indicator light should work normally.

**CONNECTOR: C-29**

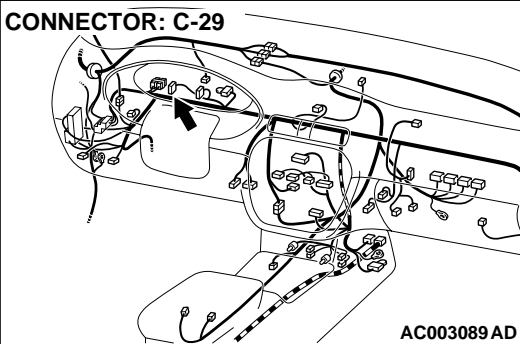

AC003089 AD

**STEP 8. Check combination meter connector C-29 and ETACS-ECU connector C-82 for damage.**

**Q: Are combination meter connector C-29 and ETACS-ECU connector C-82 in good condition?**

**YES :** Go to Step 9.

**NO :** Repair or replace them. Refer to GROUP 00E, Harness Connector Inspection [P.00E-2](#). The high-beam indicator light should work normally.

**CONNECTOR: C-82**  
JUNCTION BLOCK  
(FRONT VIEW)

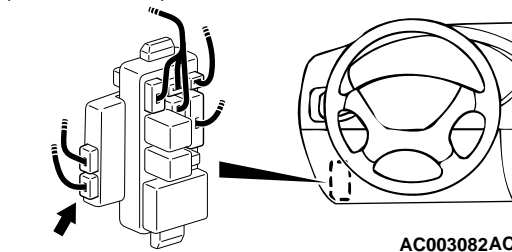

AC003082 AC

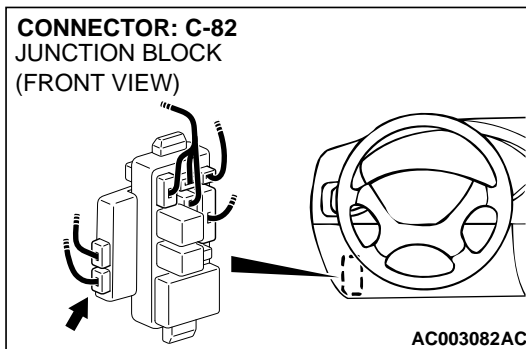
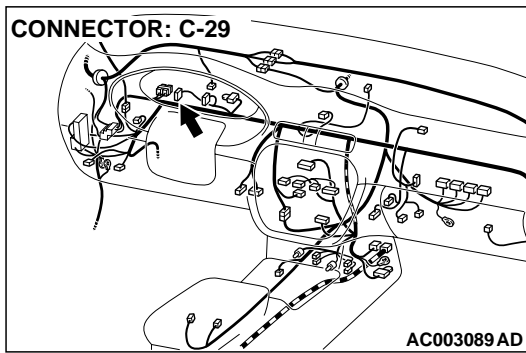

**STEP 9. Check the harness wire between combination meter connector C-29 and ETACS-ECU connector C-82.**

**Q: Is the harness wire between combination meter connector C-29 and ETACS-ECU connector C-82 in good condition?**

**YES :** There is no action to be taken.

**NO :** Repair it. The high-beam indicator light should work normally.

**STEP 10. Replacement of ECU.**

(1) Replace the ETACS-ECU.

(2) The high-beam indicator light should work normally.

**Q: Is the high-beam indicator light working normally?**

**YES :** There is no action to be taken.

**NO :** Replace the front-ECU. The high-beam indicator light should work normally.

**Inspection Procedure I-6: Headlight, taillight: Headlight automatic shutdown function does not work normally.**

**TECHNICAL DESCRIPTION (COMMENT).**

The ETACS-ECU operates the headlight automatic shutdown function, based on the signals from the following switches:

- Ignition switch (IG1)
- Driver's door switch
- Taillight switch
- Headlight switch

If the function does work normally, a defect on relevant input circuits, the ETACS-ECU or the front-ECU is suspected.

**TROUBLESHOOTING HINTS**

- Malfunction of the driver's door switch)
- Malfunction of the taillight switch
- Malfunction of the headlight switch
- Malfunction of the ETACS-ECU
- Malfunction of the front-ECU
- Damaged harness wires or connectors

**DIAGNOSIS**

**Required Special Tools:**

- MB991502: Scan Tool (MUT-II)

- MB991529: Diagnostic Trouble Code Check Harness

**STEP 1. Check the DTC.**

**Q: Does the DTC set when the ignition switch is turned to the "LOCK" (OFF) position?**

**YES :** Carry out the troubleshooting by referring to Diagnostic Trouble Code Chart. Refer to [P.54B-8](#).

**NO :** Go to Step 2 <when using scan tool MB991502> or 3 <when using a voltmeter>.

**STEP 2. Check the input signal (by using scan tool MB991502).**

Check the input signals from the following switches.

- Ignition switch (IG1)
- Driver's door switch
- Taillight switch
- Headlight switch

**⚠ CAUTION**

**To prevent damage to scan tool MB991502, always turn the ignition switch to the "LOCK" (OFF) position before connecting or disconnecting scan tool MB991502.**

- (1) Connect scan tool MB991502 to the data link connector.
- (2) Check that the tone alarm of scan tool MB991502 sounds when the input signal enters.

**Q: Does the tone alarm of scan tool MB991502 sound when the input signal enters?**

**YES :** Go to Step 4.

**NO :** Check the relevant input signal circuit. Refer to [P.54B-9](#).

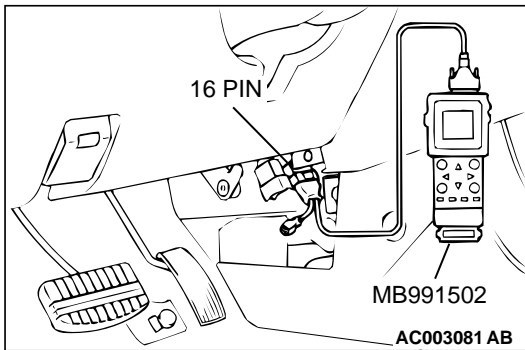

**STEP 3. Check the input signal (by using a voltmeter).**

Check the input signals from the following switches.

- Ignition switch (IG1)
- Driver's door switch
- Taillight switch
- Headlight switch

- (1) Use special tool MB991529 to connect a voltmeter between ground terminal 4 or 5 and ETACS-ECU terminal 9 of the data link connector.
- (2) Check that the voltmeter indicator deflects once when the input signal enters.

**Q: Does the voltmeter indicator deflect?**

**YES :** Go to Step 4.

**NO :** Check the relevant input signal circuit. Refer to [P.54B-9](#).

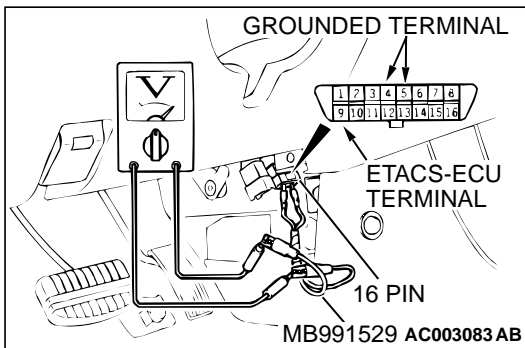

**STEP 4. Replacement of ECU.**

- (1) Replace the front-ECU.
- (2) The headlight automatic shutdown function should work normally.

**Q: Is the headlight automatic shutdown function working normally?****YES** : There is no action to be taken.**NO** : Replace the ETACS-ECU. The headlight automatic shutdown function should work normally.

---

**Inspection Procedure I-7: Headlight, taillight: Headlight dimmer switch automatic resetting function does not work normally.**

---

**TECHNICAL DESCRIPTION (COMMENT).**

The headlight dimmer switch automatic resetting function is controlled by the front-ECU. If a defect appears, the front-ECU may be defective.

**TROUBLESHOOTING HINT**

Malfunction of the front-ECU

**DIAGNOSIS**

Replace the front-ECU.

The headlight dimmer switch automatic resetting function should work normally.

**Inspection Procedure J-1: Flasher timer: Turn-signal lights does not flash when the turn-signal light switch is turned on.**

**Turn-signal Light Drive Circuit**



W1S09M16AA

AC004213

**TSB Revision**

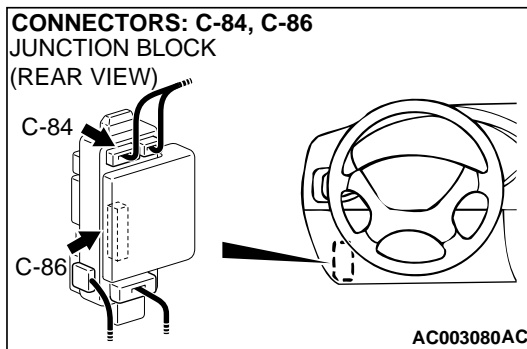
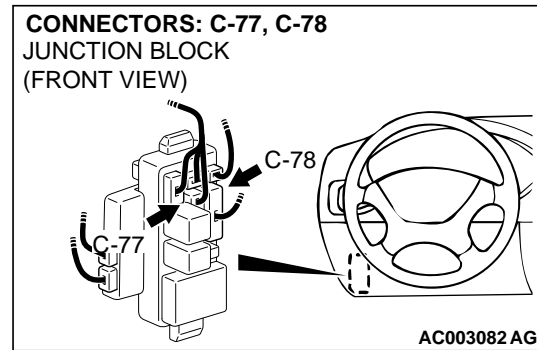
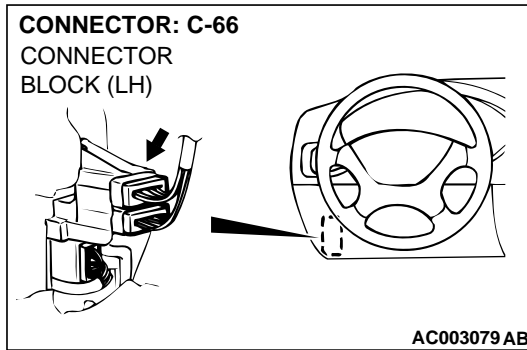

### CIRCUIT OPERATION

If the ETACS-ECU receives a signal from the turn-signal light switch, the flasher timer circuit (which is incorporated in the ETACS-ECU) makes the turn-signal lights flash.

### TECHNICAL DESCRIPTION (COMMENT)

The ETACS-ECU makes the turn-signal lights flash, based on the input signals from the following switches:

- Ignition switch (IG1)
- Turn-signal light switch

If the turn-signal lights do not flash normally, a defect on the relevant circuits or the ETACS-ECU may be suspected.

If the hazard warning lights also do not flash, a defect in the ETACS-ECU power supply line specific to the turn-signal lights is suspected.

*NOTE: If only one of the turn-signal lights does not flash, the light bulb may be burned out or the harness wires between the ETACS-ECU and the light may be defective. In this case, check the circuit by referring to GROUP 90, Turn-signal Light and Hazard Warning Light P.90-80.*

### TROUBLESHOOTING HINTS

- Malfunction of the column switch (turn-signal light and lighting switch)
- Malfunction of the ETACS-ECU
- Damaged harness wires or connectors

### DIAGNOSIS

#### Required Special Tools:

- MB991223: Test Harness Set
- MB991502: Scan Tool (MUT-II)
- MB991529: Diagnostic Trouble Code Check Harness

#### STEP 1. Check the hazard warning light operation.

#### Q: Do the hazard warning lights work normally?

**YES** : Go to Step 8 <when using scan tool MB991502> or 9 <when using a voltmeter>.

**NO** : Go to Step 2.



**STEP 2. Check turn-signal light state operation.**

**Q: Does any turn-signal lights flash?**

**YES (only one side illuminates) :** Go to Step 3.

**NO (no lights flash at all) :** Go to Step 5.

**STEP 3. Check ETACS-ECU connector C-86 and junction block connectors C-77, C-78 and C-84 for damage.**

**Q: Are ETACS-ECU connector C-86 and junction block connectors C-77, C-78 and C-84 in good condition?**

**YES :** Go to Step 4.

**NO :** Repair or replace them. Refer to GROUP 00E, Harness Connector Inspection [P.00E-2](#) . The turn-signal lights should flash normally.

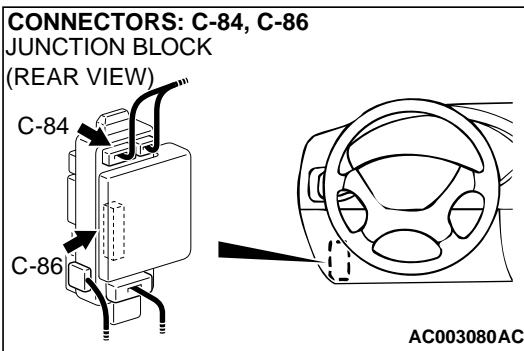
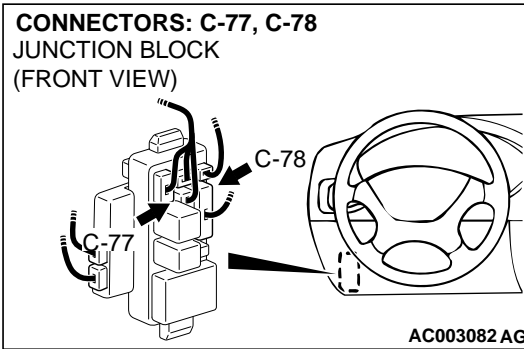

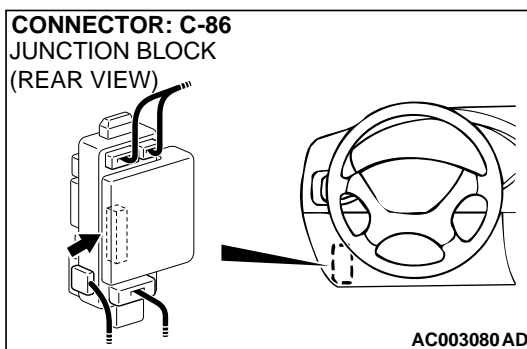
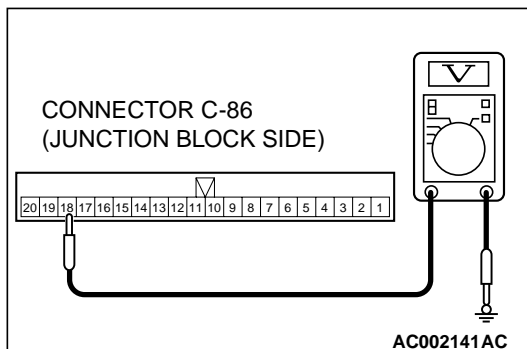
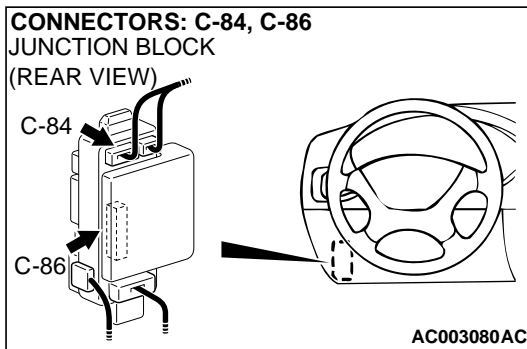
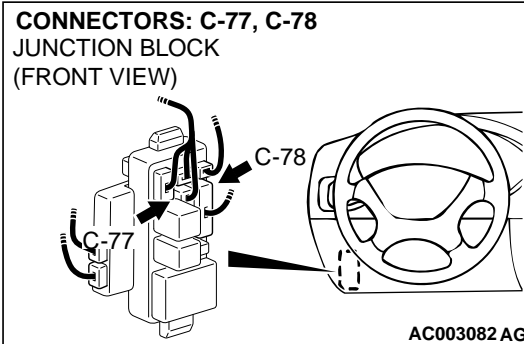

**STEP 4. Check the harness wires between ETACS-ECU connector C-86 and junction block connectors C-77, C-78 and C-84.**

**Q: Are the harness wires between ETACS-ECU connector C-86 and junction block connectors C-77, C-78 and C-84 in good condition?**

**YES :** Replace the ETACS-ECU. The turn-signal lights should flash normally.

**NO :** Repair them. The turn-signal lights should flash normally.

**STEP 5. Check the ETACS-ECU power supply circuit (for turn-signal light) at the ETACS-ECU connector C-86.**

(1) Disconnect the ETACS-ECU connector C-86 and measure at the junction block side.

(2) Measure the voltage between terminal 18 and ground.

**Q: Is the voltage approximately 12 volts (battery positive voltage)?**

**YES :** Replace the ETACS-ECU. The turn-signal lights should flash normally.

**NO :** Go to Step 6.

**STEP 6. Check ETACS-ECU connector C-86 for damage.**

**Q: Is ETACS-ECU connector C-86 in good condition?**

**YES :** Go to Step 7.

**NO :** Repair or replace it. Refer to GROUP 00E, Harness Connector Inspection [P.00E-2](#) . The turn-signal lights should flash normally.

**STEP 7. Check the harness wires between ETACS-ECU connector C-86 and battery.**

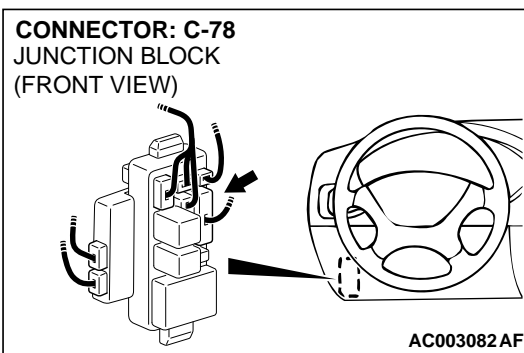
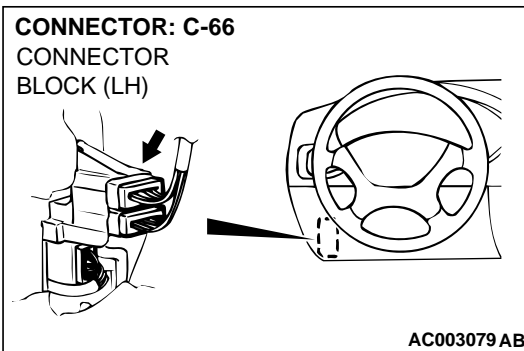
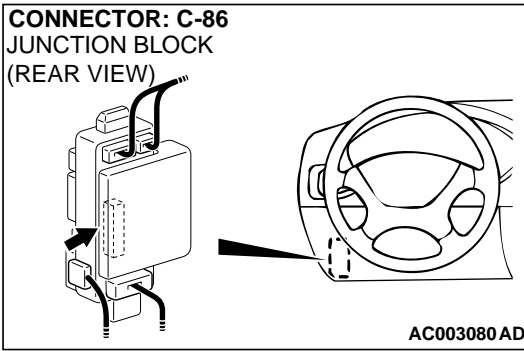

*NOTE: After checking junction block connector C-78 and intermediate connector C-66, check the wires. If junction block connector C-78 and intermediate connector C-66 are damaged, repair or replace them. Refer to GROUP 00E, Harness Connector Inspection [P.00E-2](#).*

**Q: Are the harness wires between ETACS-ECU connector C-86 and battery in good condition?**

**YES :** There is no action to be taken.

**NO :** Repair them. The turn-signal lights should flash normally.

**STEP 8. Check the input signal (by using scan tool MB991502).**

Check the input signals from the following switches.

- Ignition switch (IG1)
- Turn-signal light switch

**CAUTION**

To prevent damage to scan tool MB991502, always turn the ignition switch to the "LOCK" (OFF) position before connecting or disconnecting scan tool MB991502.

- (1) Connect scan tool MB991502 to the data link connector.
- (2) Check that the tone alarm of scan tool MB991502 sounds when the input signal enters.

**Q: Does the tone alarm of scan tool MB991502 sound when the input signal enters?**

**YES** : Replace the ETACS-ECU. The turn-signal lights should flash normally.

**NO** : Check the relevant input signal circuit. Refer to P.54B-9 .

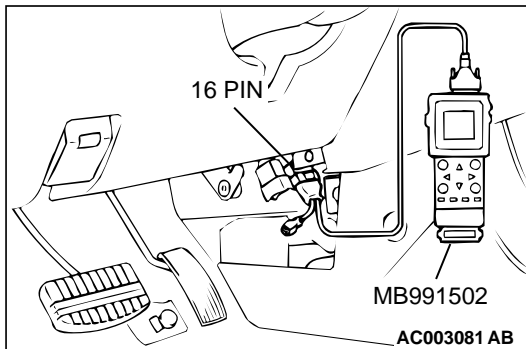
**STEP 9. Check the input signal (by using a voltmeter).**

Check the input signals from the following switches.

- Ignition switch (IG1)
- Turn-signal light switch

- (1) Use special tool MB991529 to connect a voltmeter between ground terminal 4 or 5 and ETACS-ECU terminal 9 of the data link connector.
- (2) Check that the voltmeter indicator deflects once when the input signal enters.

**Q: Does the voltmeter indicator deflect?**

**YES** : Replace the ETACS-ECU. The turn-signal lights should flash normally.

**NO** : Check the relevant input signal circuit. Refer to P.54B-9 .

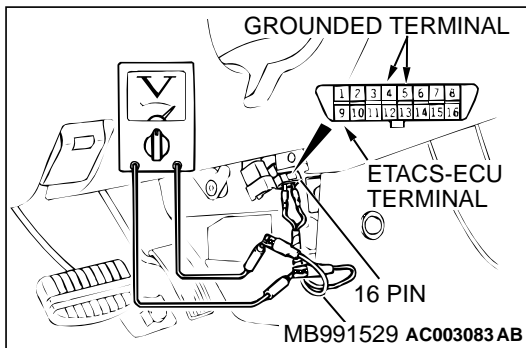
**Inspection Procedure J-2: Flasher timer: Hazard warning lights does not flash when the hazard warning light switch is turned on.****Turn-signal Light Drive Circuit**

- Refer to Inspection Procedure J-1 (P.54B-144).

**CIRCUIT OPERATION**

If the ETACS-ECU receives a signal from the hazard warning light switch, the flasher timer circuit (which is incorporated in the ETACS-ECU) makes the turn-signal lights flash.

**TECHNICAL DESCRIPTION (COMMENT)**

The ETACS-ECU makes the turn-signal lights flash, based on the input signals from the hazard warning light switch. If the turn-signal lights do not flash normally, the hazard warning light switch input circuit or the ETACS-ECU may be defective.

If the turn-signal lights do not flash, a defect in the ETACS-ECU power supply line specific to the turn-signal lights is suspected.

*NOTE: If only one of the turn-signal lights does not flash, the light bulb may be burned out or the harness wires between the ETACS-ECU and the light may be defective. In this case, check the circuit by referring to GROUP 90, Turn-signal Light and Hazard Warning Light P.90-80 .*

**TROUBLESHOOTING HINTS**

- Malfunction of the hazard warning light switch
- Malfunction of the ETACS-ECU
- Damaged harness wires or connectors

**DIAGNOSIS**

**Required Special Tools:**

- MB991502: Scan Tool (MUT-II)
- MB991529: Diagnostic Trouble Code Check Harness

**STEP 1. Check the turn-signal light operation.**

**Q: Do the turn-signal lights work normally?**

- YES :** Go to Step 2 <when using scan tool MB991502> or 3 <when using a voltmeter>.
- NO :** Solve the problem first. Refer to Inspection Procedure J-1 (P.54B-144 ).

**STEP 2. Check the input signal (by using scan tool MB991502).**

Check the input signals from the hazard warning light switch.

**⚠ CAUTION**

**To prevent damage to scan tool MB991502, always turn the ignition switch to the "LOCK" (OFF) position before connecting or disconnecting scan tool MB991502.**

- (1) Connect scan tool MB991502 to the data link connector.
- (2) Check that the tone alarm of scan tool MB991502 sounds when the input signal enters.

**Q: Does the tone alarm of scan tool MB991502 sound when the input signal enters?**

- YES :** Replace the ETACS-ECU. The hazard warning lights should flash normally.
- NO :** Check the hazard warning light switch input circuit. Refer to Inspection Procedure N-4 (P.54B-190).

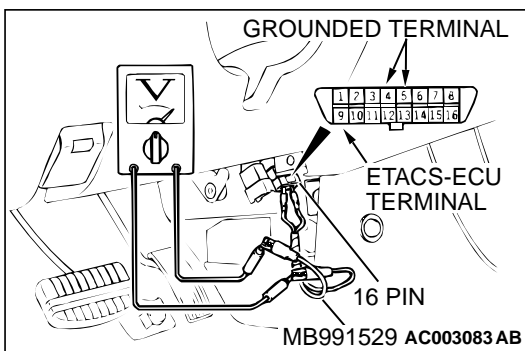
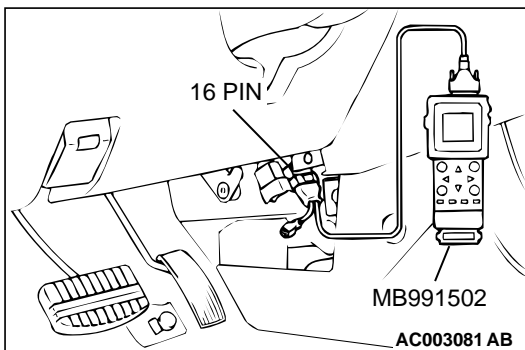

**STEP 3. Check the input signal (by using a voltmeter).**

Check the input signals from the hazard warning light switch.

- (1) Use special tool MB991529 to connect a voltmeter between ground terminal 4 or 5 and ETACS-ECU terminal 9 of the data link connector.
- (2) Check that the voltmeter indicator deflects once when the input signal enters.

**Q: Does the voltmeter indicator deflect?**

- YES :** Replace the ETACS-ECU. The hazard warning lights should flash normally.
- NO :** Check the hazard warning light switch input circuit. Refer to Inspection Procedure N-4 (P.54B-190).

Inspection Procedure K-1: Fog light: Fog lights do not illuminate when the fog light switch is turned on.

Fog Light Relay Drive Circuit

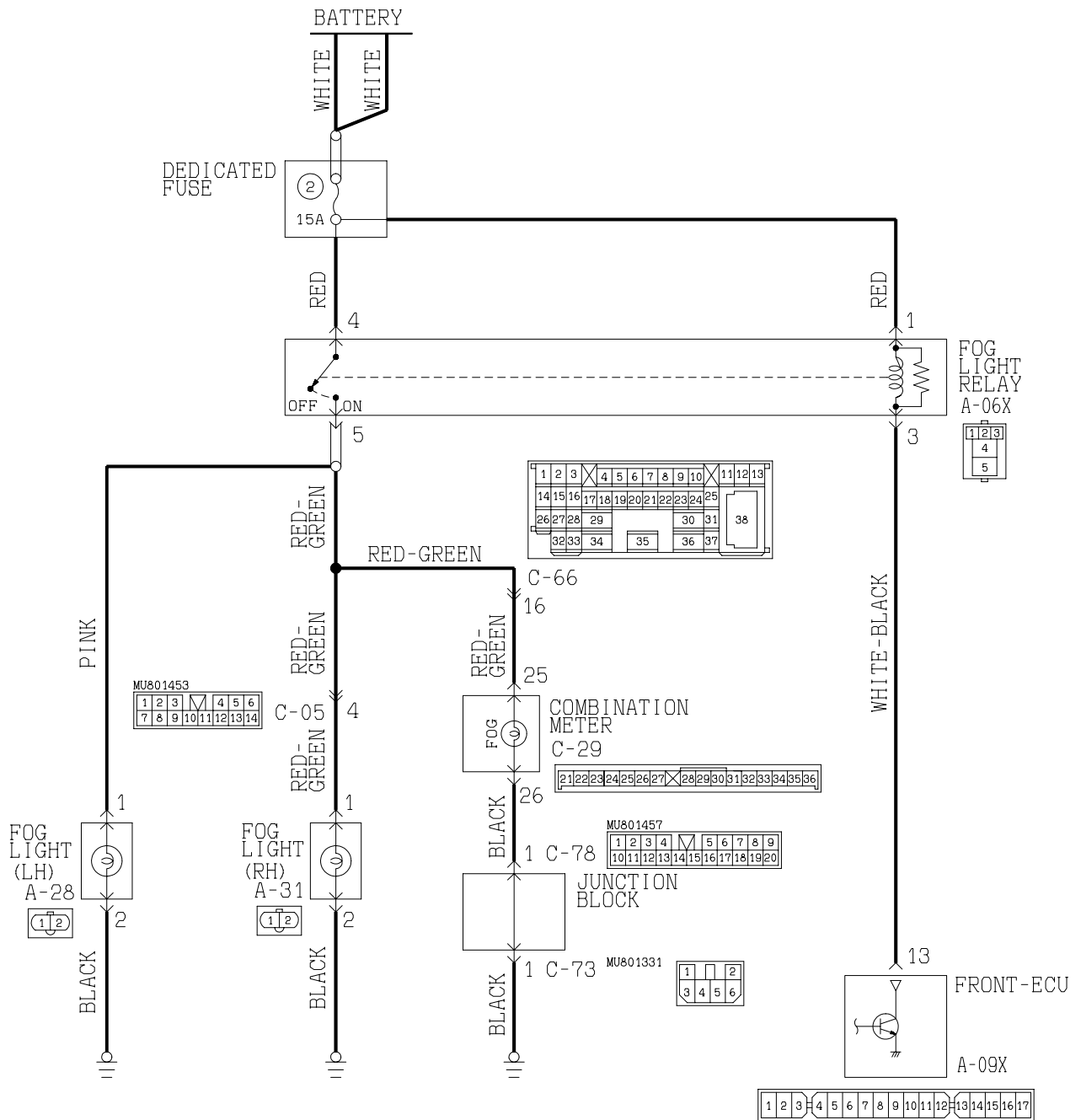

TSB Revision

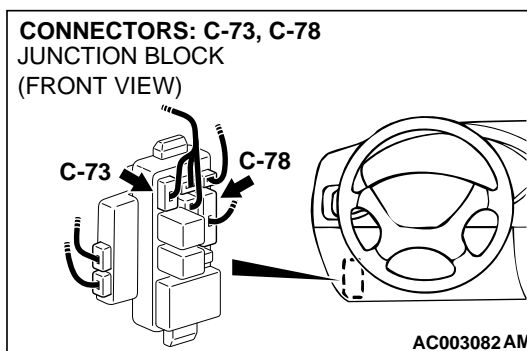
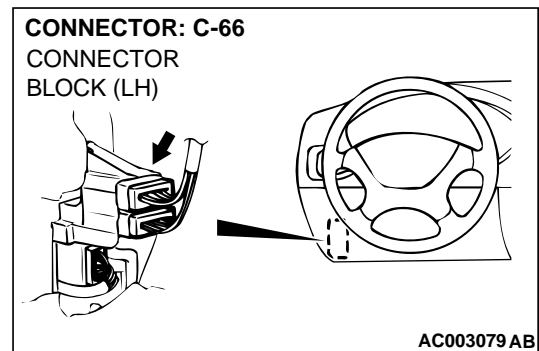
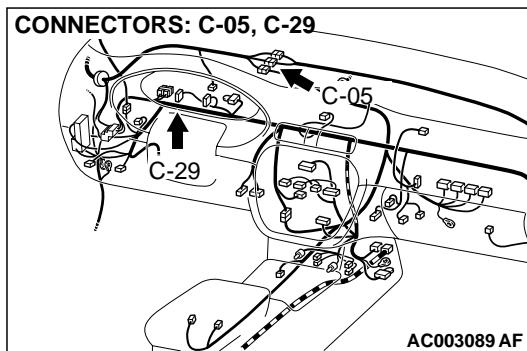
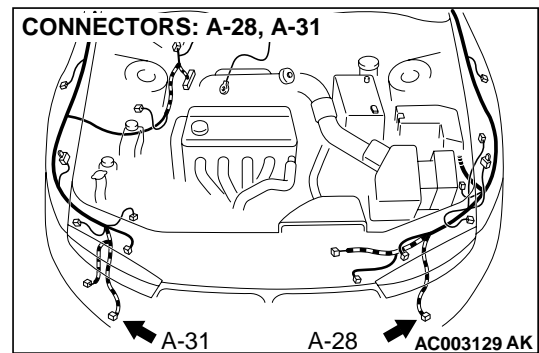
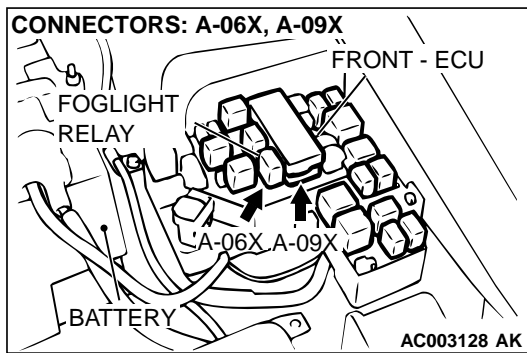

**CIRCUIT OPERATION.**

When the fog light switch is turned on while the front-ECU is illuminating the taillights or headlights (low-beam), the ETACS-ECU sends a 'light on' signal to the front-ECU, causing the front-ECU to illuminate the fog lights.

**TECHNICAL DESCRIPTION (COMMENT)**

If the taillights and headlights illuminate normally, the fog light relay, the fog light switch, the front-ECU or the ETACS-ECU may be defective.

*NOTE: If only one of the fog lights or the fog light indicator light does not illuminate, the relevant bulb may be burned out or the harness wire between the defective light and the fog light relay may be defective. In this case, check the relevant circuit by referring to GROUP 90, Fog Light P.90-68.*

**TROUBLESHOOTING HINTS**

- Malfunction of the fog light relay
- Malfunction of the fog light switch
- Malfunction of the front-ECU
- Malfunction of the ETACS-ECU
- Damaged harness wires or connectors

**DIAGNOSIS**

**Required Special Tools:**

- MB991223: Test Harness Set
- MB991502: Scan Tool (MUT-II)
- MB991529: Diagnostic Trouble Code Check Harness

**STEP 1. Check the taillights and headlight operation.**

**Q: Do the taillights and headlights illuminate normally?**

**YES :** Go to Step 2 <when using scan tool MB991502> or 3 <when using a voltmeter>.

**NO :** Solve the problem first. Refer to [P.54B-9](#).

**STEP 2. Check the input signal (by using scan tool MB991502).**

Check the input signals from the fog light switch.

**⚠ CAUTION**

To prevent damage to scan tool MB991502, always turn the ignition switch to the "LOCK" (OFF) position before connecting or disconnecting scan tool MB991502.

- (1) Connect scan tool MB991502 to the data link connector.
- (2) Check that the tone alarm of scan tool MB991502 sounds when the input signal enters.

**Q: Does the tone alarm of scan tool MB991502 sound when the input signal enters?**

**YES :** Go to Step 4.

**NO :** Check the fog light input signal circuit. Refer to Inspection Procedure N-5 ([P.54B-194](#)).

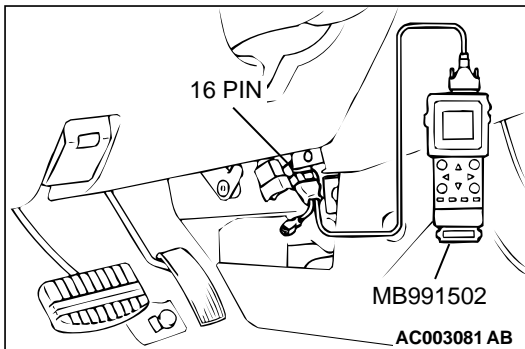

**STEP 3. Check the input signal (by using a voltmeter).**

Check the input signals from the fog light switch.

- (1) Use special tool MB991529 to connect a voltmeter between ground terminal 4 or 5 and ETACS-ECU terminal 9 of the data link connector.
- (2) Check that the voltmeter indicator deflects once when the input signal enters.

**Q: Does the voltmeter indicator deflect?**

**YES :** Go to Step 4.

**NO :** Check the fog light input signal circuit. Refer to Inspection Procedure N-5 ([P.54B-194](#)).

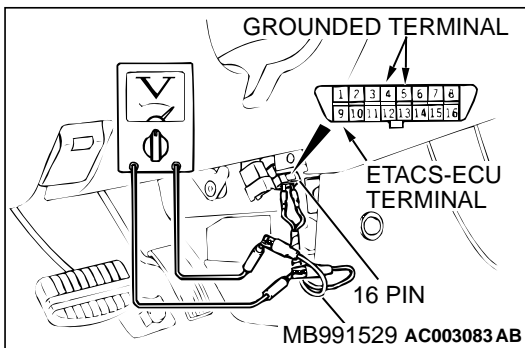

**STEP 4. Check the fog light relay.**

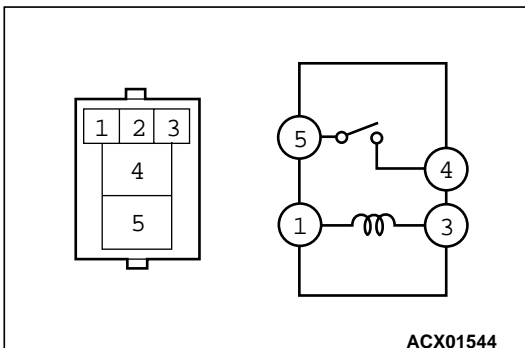

BATTERY VOLTAGE	TESTER CONNECTION	SPECIFIED CONDITION
Not applied	1 – 3	Continuity
1 – Battery (+) terminal, 3 – Battery (–) terminal	4 – 5	Continuity

**Q: Is the fog light relay in good condition?**

**YES :** Go to Step 5.

**NO :** Replace it. The fog lights should illuminate normally.



**STEP 5. Check the fog light relay power supply circuit at the fog light relay connector A-06X.**

- (1) Disconnect the fog light relay connector A-06X and measure at the relay box side.
- (2) Measure the voltages between terminal 1, 4 and ground.

**Q: Are the voltages approximately 12 volts (battery positive voltage)?**

**YES :** Go to Step 8.

**NO :** Go to Step 6.

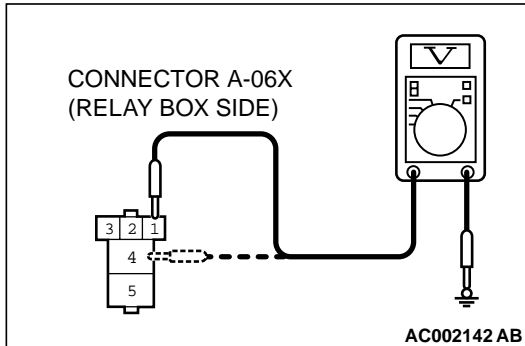

**STEP 6. Check fog light relay connector A-06X for damage.**

**Q: Is fog light relay connector A-06X in good condition?**

**YES :** Go to Step 7.

**NO :** Repair or replace it. Refer to GROUP 00E, Harness Connector Inspection [P.00E-2](#) . The fog lights should illuminate normally.

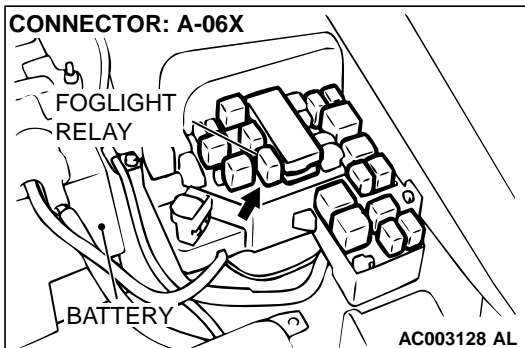

**STEP 7. Check the harness wire between fog light relay connector A-06X and battery.**

**Q: Is the harness wire between fog light relay connector A-06X and battery in good condition?**

**YES :** There is no action to be taken.

**NO :** Repair it. The fog lights should illuminate normally.

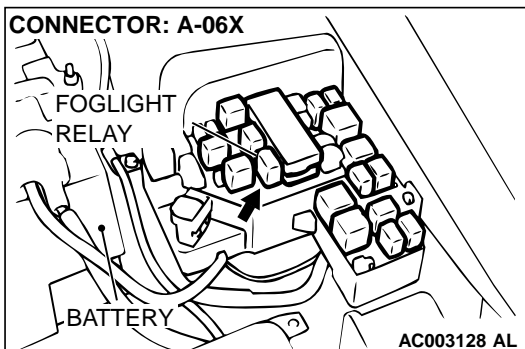

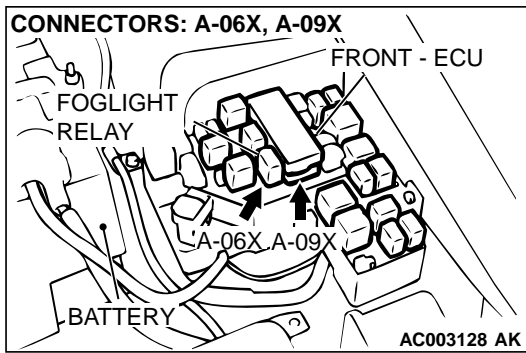

**STEP 8. Check fog light relay connector A-06X and front-ECU connector A-09X for damage.**

**Q: Are fog light relay connector A-06X and front-ECU connector A-09X in good condition?**

**YES :** Go to Step 9.

**NO :** Repair or replace them. Refer to GROUP 00E, Harness Connector Inspection [P.00E-2](#) . The fog lights should illuminate normally.

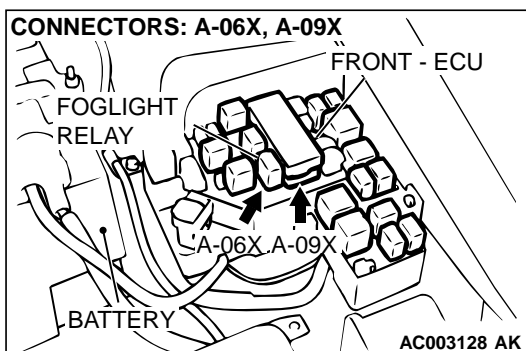

**STEP 9. Check the harness wire between fog light relay connector A-06X and front-ECU connector A-09X.**

**Q: Is the harness wire between fog light relay connector A-06X and front-ECU connector A-09X in good condition?**

**YES :** Go to Step 10.

**NO :** Repair it. The fog lights should illuminate normally.

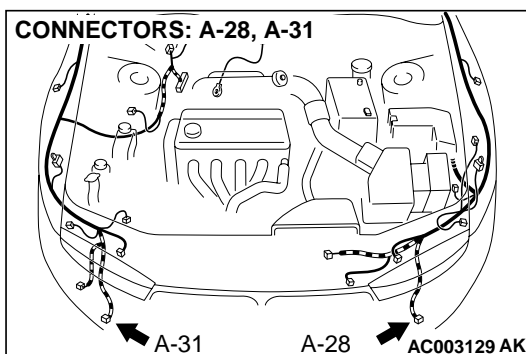

**STEP 10. Check fog light connectors A-28 and A-31 and combination meter connector C-29 for damage.**

**Q: Are fog light connectors A-28 and A-31 and combination meter connector C-29 in good condition?**

**YES :** Go to Step 11.

**NO :** Repair or replace them. Refer to GROUP 00E, Harness Connector Inspection [P.00E-2](#) . The fog lights should illuminate normally.

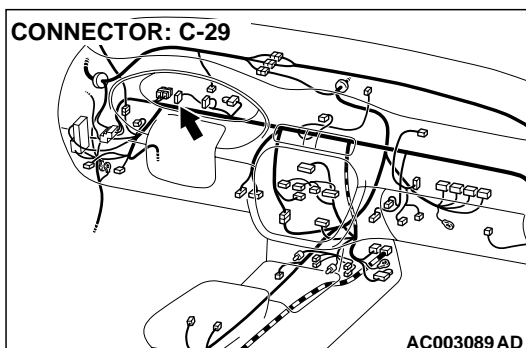

**STEP 11. Check the harness wires between fog light relay connector A-06X and fog light connectors A-28 and A-31 and combination meter connector C-29.**

*NOTE: After checking intermediate connectors C-05 and C-66, check the wires. If intermediate connectors C-05 and C-66 are damaged, repair or replace them. Refer to GROUP 00E, Harness Connector Inspection P.00E-2 .*

**Q: Are the harness wires between fog light relay connector A-06X and fog light connectors A-28 and A-31 and combination meter connector C-29 in good condition?**

**YES :** Go to Step 12.

**NO :** Repair them. The fog lights should illuminate normally.

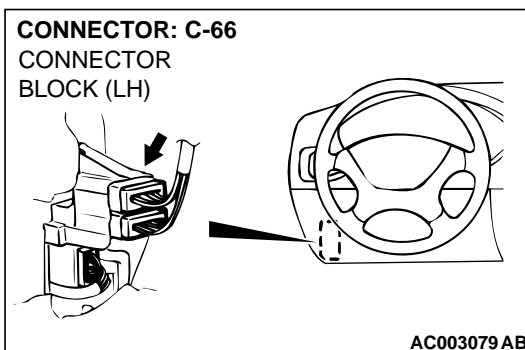
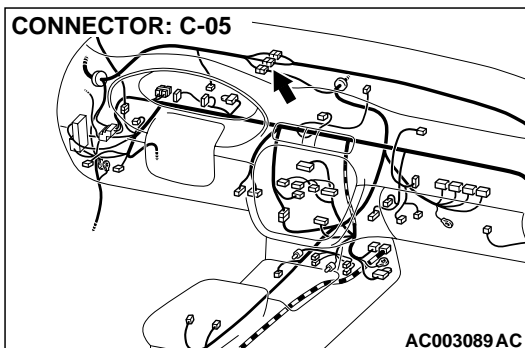
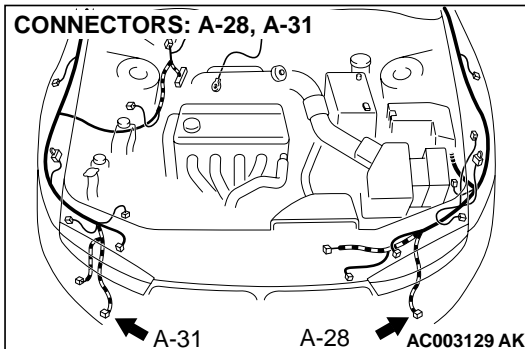
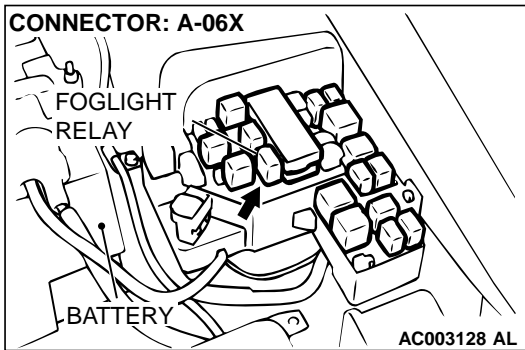

---

**STEP 12. Replacement of ECU**

- (1) Replace the front-ECU.
- (2) The fog lights should illuminate normally.

**Q: Do the fog lights illuminate normally?**

**YES** : There is no action to be taken.

**NO** : Replace the ETACS-ECU. The fog light should illuminate normally.

---

**Inspection Procedure K-2: Fog light: Fog lights do not go out when the headlights (low-beam) are turned off while the fog lights are on.**

---

**TECHNICAL DESCRIPTION (COMMENT).**

If the malfunction above occurs, the front-ECU may be defective.

**TROUBLESHOOTING HINT**

Malfunction of the front-ECU

**DIAGNOSIS**

Replace the front-ECU.

The fog lights should go out when the headlights (low-beam) are turned off while the fog lights are on.

**Inspection Procedure L-1: Dome light: Dome light does not illuminate.**

**Dome Light Drive Circuit**

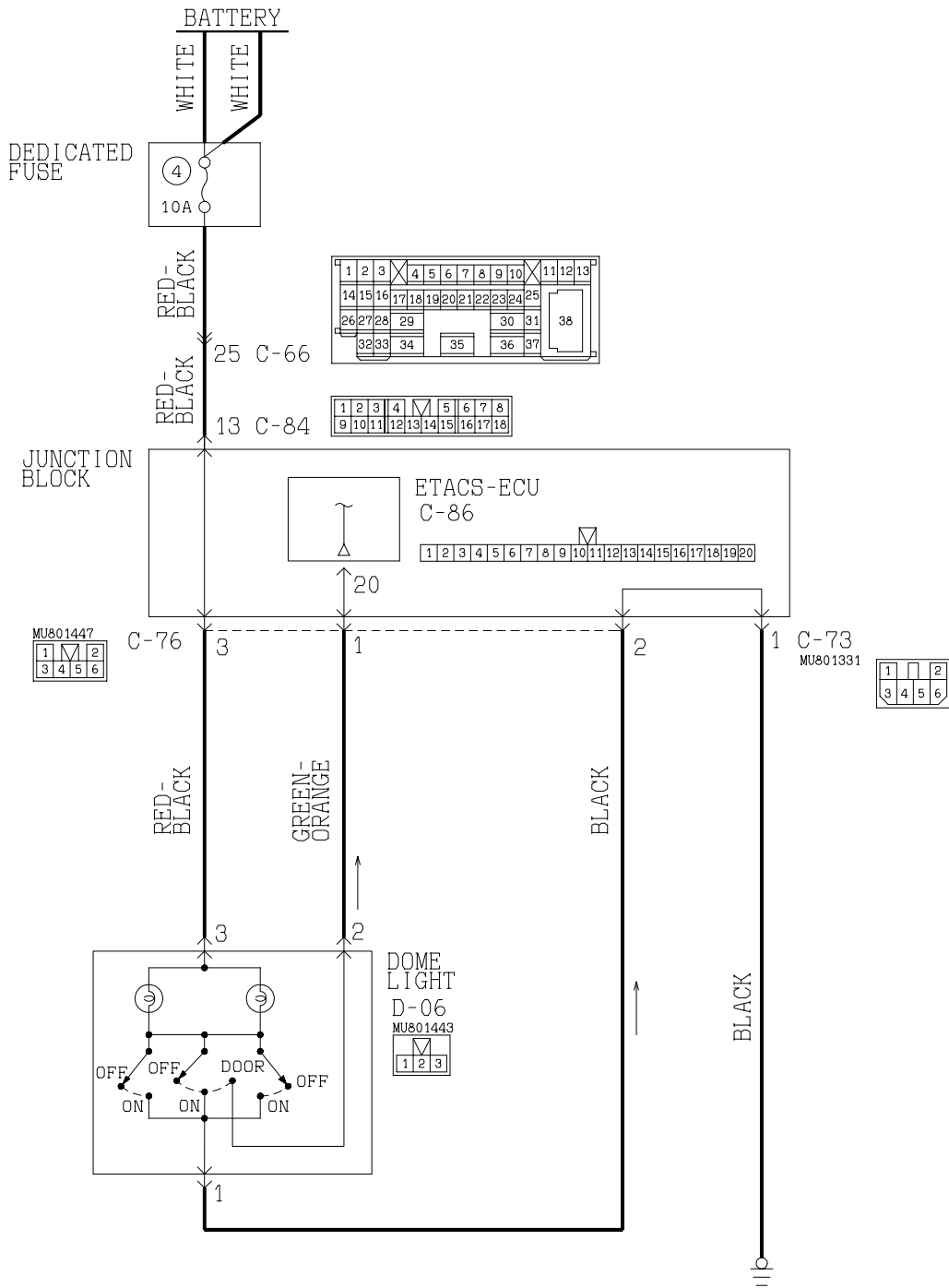

W1S09M18AA

**AC004215**

**TSB Revision**

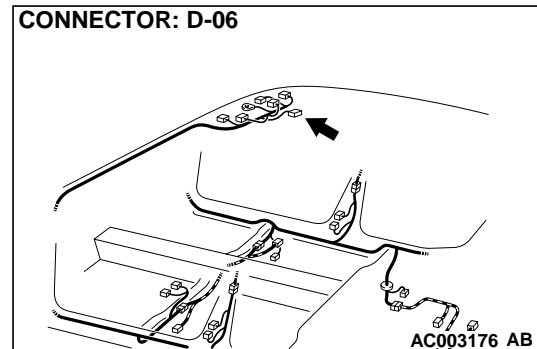
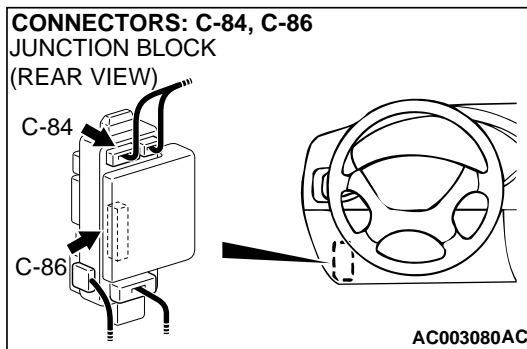
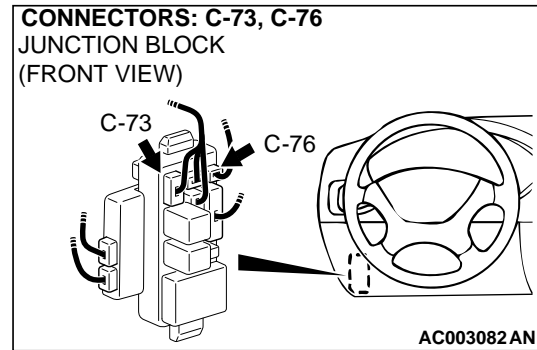
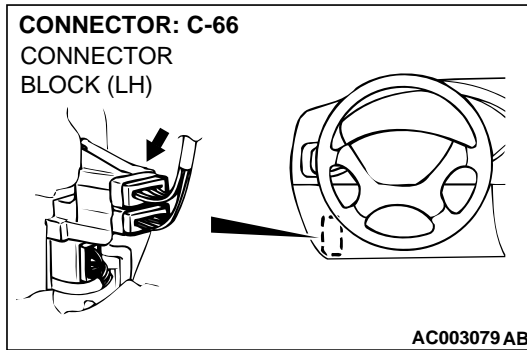

### CIRCUIT OPERATION

The dome light dimming function and the keyless entry system answerback function illuminate the dome light when the dome light switch is at "door controlled operation position."

### TECHNICAL DESCRIPTION (COMMENT)

If the dome light dose not illuminate at all, the dome light bulb may be burned out, or the power supply circuit or the ETACS-ECU may be defective.

### TROUBLESHOOTING HINTS

- Malfunction of the dome light
- Malfunction of the ETACS-ECU
- Damaged harness wires or connectors

### DIAGNOSIS

#### Required Special Tools:

- MB991223: Test Harness Set

#### STEP 1. Check the trouble symptom.

**Q: Does the dome light illuminate when the dome light switch is turned to "ON" position?**

**YES :** Go to Step 2.

**NO :** Go to Step 3.

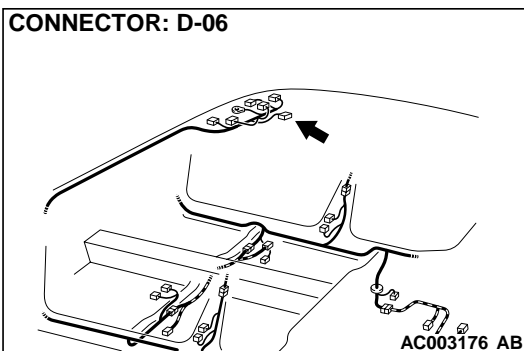
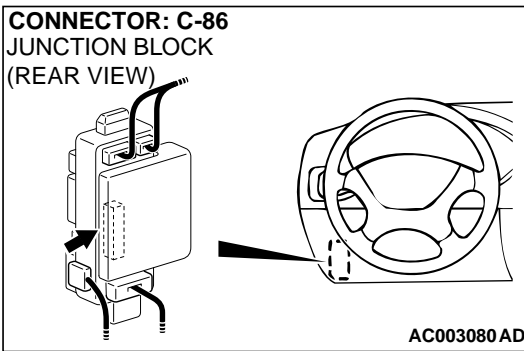

**STEP 2. Check the dome light connector D-06 and ETACS-ECU connectors C-86 for damage.**

**Q: Are dome light connector D-06 and ETACS-ECU connectors C-86 in good condition?**

**YES :** Go to Step 3.

**NO :** Repair or replace them. Refer to GROUP 00E, Harness Connector Inspection [P.00E-2](#) . The dome lights should illuminate normally.

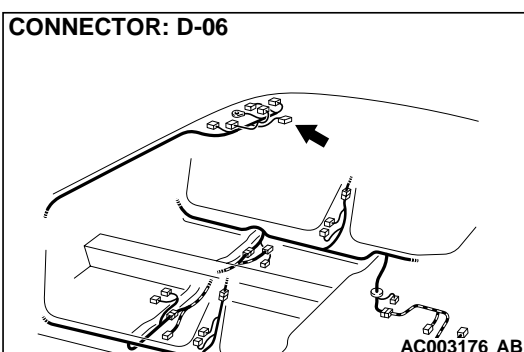
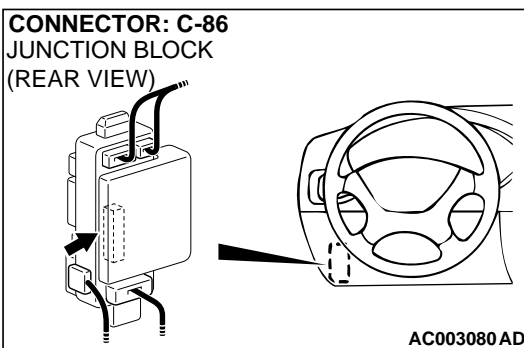

**STEP 3. Check the harness wire between dome light connector D-06 and ETACS-ECU connectors C-86.**

**Q: Is the harness wire between dome light connector D-06 and ETACS-ECU connectors C-86 in good condition?**

**YES :** Replace the ETACS-ECU. The dome lights should illuminate normally.

**NO :** Repair it. The dome lights should illuminate normally.

**Inspection Procedure L-2: Dome light: Dome light dimming function does not work normally.****TECHNICAL DESCRIPTION (COMMENT)**

The ETACS-ECU dims the dome light according to the input signals from the following switches :

**TROUBLESHOOTING HINTS**

- Malfunction of the dome light
- Malfunction of the ETACS-ECU
- Damaged harness wires or connectors

**DIAGNOSIS****Required Special Tools:**

- MB991223: Test Harness Set
- MB991502: Scan Tool (MUT-II)
- MB991529: Diagnostic Trouble Code Check Harness

**STEP 1. Check the trouble symptom.**

**Q: Does the dome light illuminate when the dome light switch is turned to "ON" position?**

**YES :** Go to Step 6.

**NO :** Go to Step 2.

**STEP 2. Check the dome light connector D-06 for damage.**

**Q: Are dome light connector D-06 in good condition?**

**YES :** Go to Step 3.

**NO :** Repair or replace them. Refer to GROUP 00E, Harness Connector Inspection [P.00E-2](#) . The dome lights should illuminate normally.

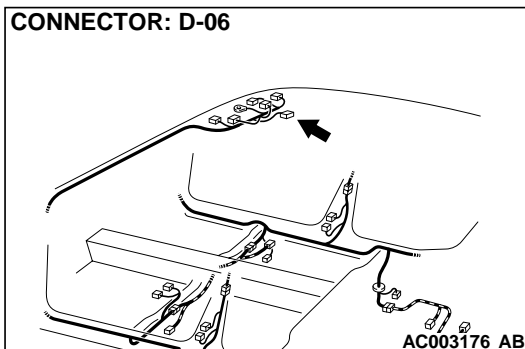
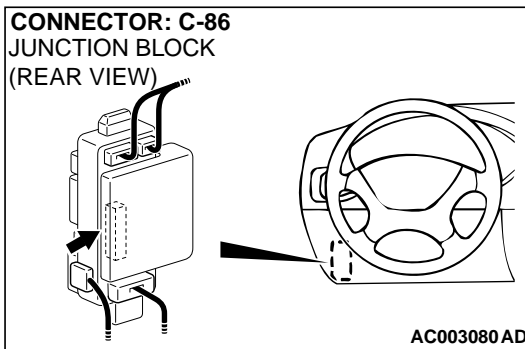



CONNECTOR: D-06

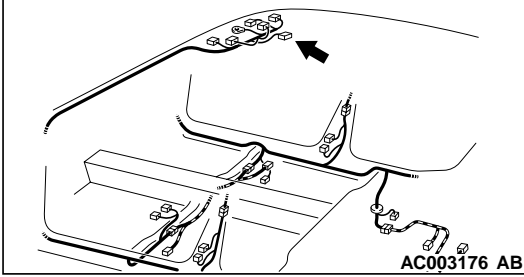

**STEP 3. Check the harness wire between dome light connector D-06 and battery.**

*NOTE: After checking junction block connector C-76 and C-84 and intermediate connector C-66, check the wires. If junction block connector C-76 and C-84 and intermediate connector C-66 are damaged, repair or replace it. Refer to GROUP 00E, Harness Connector Inspection P.00E-2 .*

**Q: Is the harness wire between dome light connector D-06 and battery in good condition?**

**YES :** Go to Step 4.

**NO :** Repair it. The interior dome should illuminate normally.

CONNECTOR: C-66  
CONNECTOR  
BLOCK (LH)

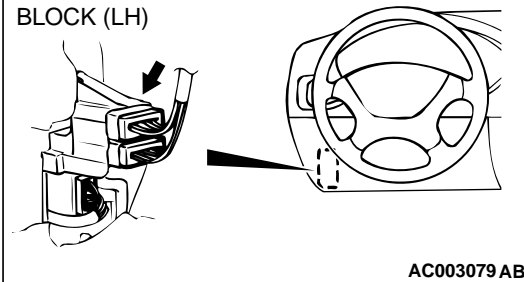

CONNECTOR: C-76  
JUNCTION BLOCK  
(FRONT VIEW)

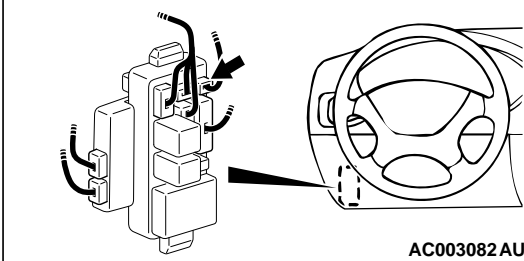

CONNECTOR: C-84  
JUNCTION BLOCK  
(REAR VIEW)

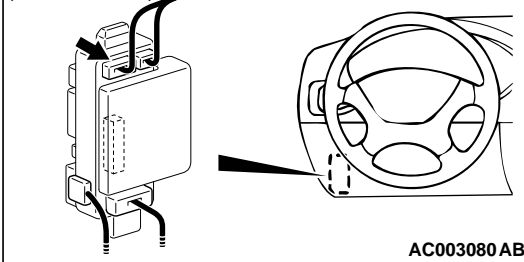

CONNECTOR: D-06

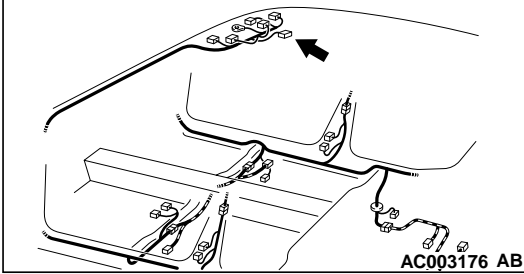

AC003176 AB

**STEP 4. Check the dome light connector D-06 for damage.****Q: Are dome light connector D-06 in good condition?****YES :** Go to Step 5.**NO :** Repair or replace them. Refer to GROUP 00E, Harness Connector Inspection [P.00E-2](#) . The dome lights should illuminate normally.

CONNECTOR: D-06

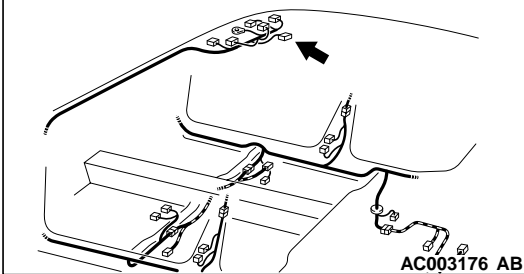

AC003176 AB

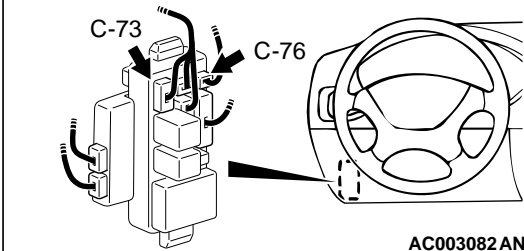
**STEP 5. Check the harness wire between dome light connector D-06 and ground.****NOTE:** After checking junction block connector C-73 and C-76 , check the wires. If junction block connector C-73 and C-76 are damaged, repair or replace it. Refer to GROUP 00E, Harness Connector Inspection [P.00E-2](#) .**Q: Is the harness wire between dome light connector D-06 and ground in good condition?****YES :** Replace the ETACS-ECU. The dome lights should illuminate normally.**NO :** Repair it. The interior dome should illuminate normally.CONNECTORS: C-73, C-76  
JUNCTION BLOCK  
(FRONT VIEW)

AC003082 AN

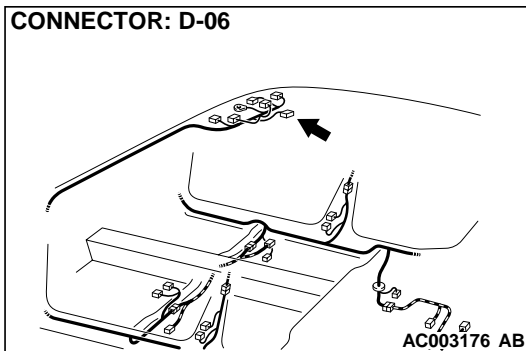
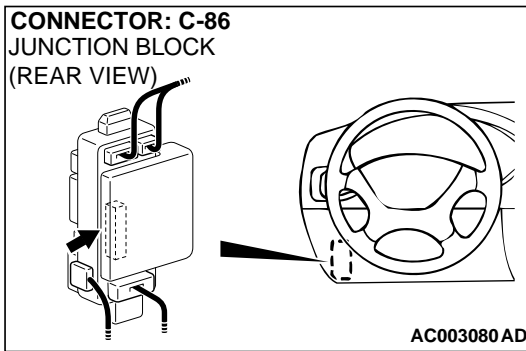

**STEP 6.** Check the dome light connector D-06 and ETACS-ECU connectors C-86 for damage.

**Q:** Are dome light connector D-06 and ETACS-ECU connectors C-86 in good condition?

**YES :** Go to Step 7.

**NO :** Repair or replace them. Refer to GROUP 00E, Harness Connector Inspection [P.00E-2](#) . The dome lights should illuminate normally.

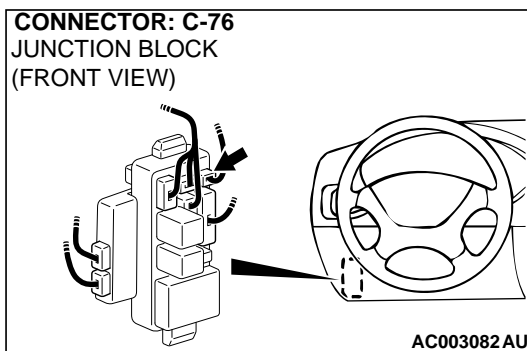
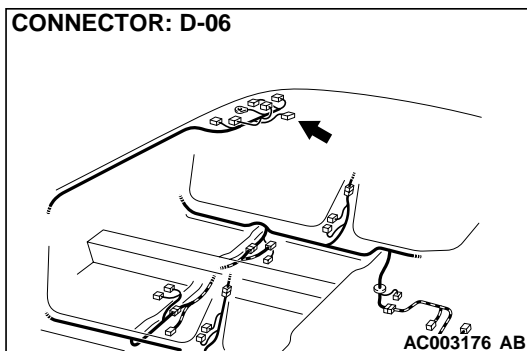
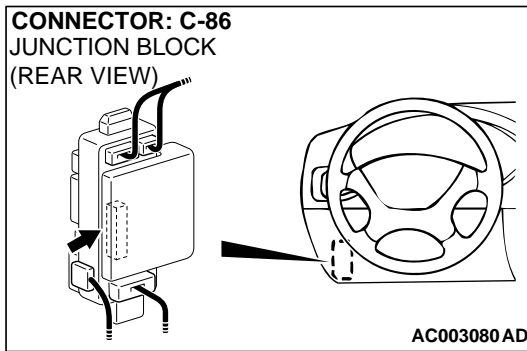

**STEP 7. Check the harness wire between dome light connector D-06 and ETACS-ECU connectors C-86.**

**NOTE:** After checking junction block connector C-76, check the wires. If junction block connector C-76 is damaged, repair or replace it. Refer to GROUP 00E, Harness Connector Inspection P.00E-2.

**Q: Is the harness wire between dome light connector D-06 and ETACS-ECU connectors C-86 in good condition?**

**YES :** Replace the ETACS-ECU. The dome lights should illuminate normally.

**NO :** Repair it. The interior dome should illuminate normally.

**Inspection Procedure M-1: Theft-alarm system: Theft-alarm system is not armed (security indicator light does not illuminate).**

**"SECURITY" Indication Light Circuit**

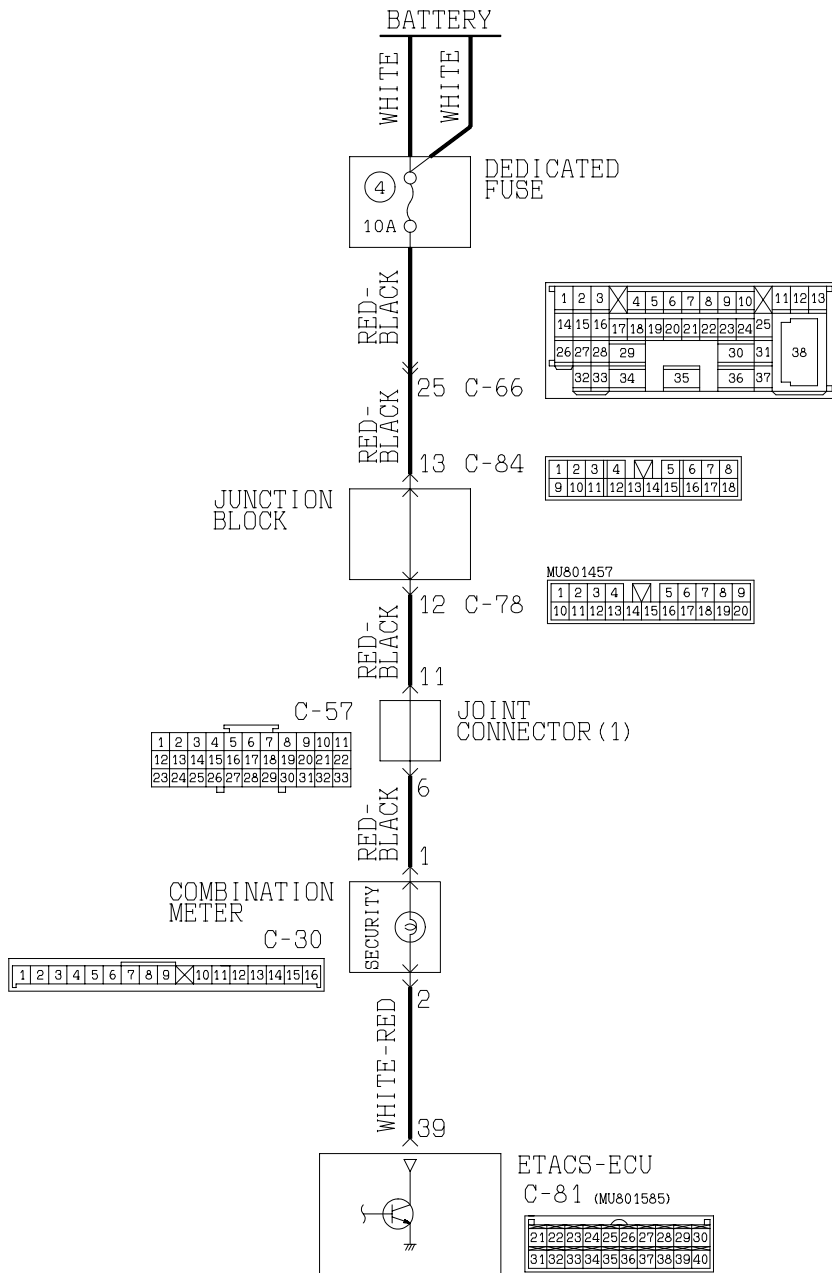

W1S09M19AA  
AC004216

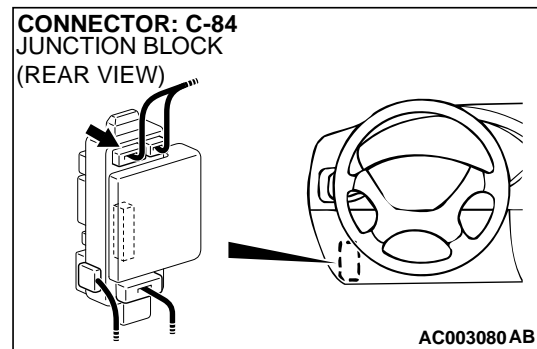
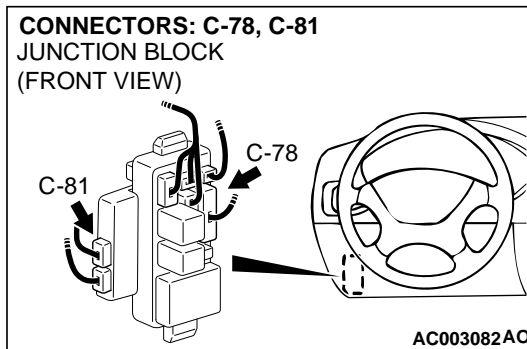
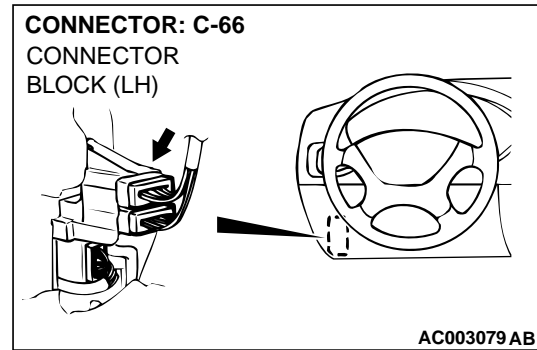
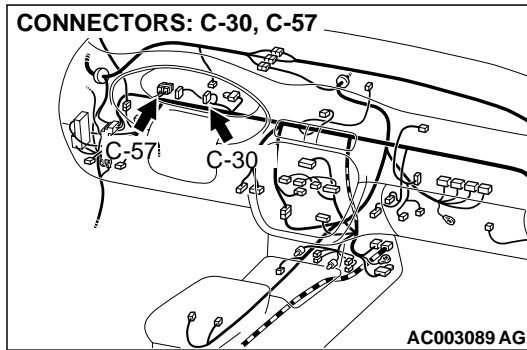

### CIRCUIT OPERATION

The theft-alarm system will be armed after the doors are locked and then the security indicator light has illuminated for approximately 18 seconds.

### TECHNICAL DESCRIPTION (COMMENT)

The ETACS-ECU arms the theft-alarm system according to the input signals from the following switches:

- Ignition key reminder switch
- Driver's and front passenger's door switch
- Door switches
- Driver's and front passenger's door key cylinder switch
- Driver's, front passenger's rear door lock actuator switch
- Hood switch
- Trunk lid latch switch
- Trunk lid lock key cylinder switch
- Transmitter

If the theft-alarm system is armed normally, the relevant input signal circuit(s), the "SECURITY" indicator light or the ETACS-ECU may be defective.

### TROUBLESHOOTING HINTS

- Malfunction of the combination meter ("SECURITY" indicator light bulb or printed-circuit board)
- Malfunction of the ignition key reminder switch
- Malfunction of the driver's, or front passenger's or rear door switch
- Malfunction of the driver's or front passenger's door lock key cylinder switch
- Malfunction of the driver's or front passenger's door lock actuator switch
- Malfunction of the hood switch
- Malfunction of the trunk lid latch switch
- Malfunction of the trunk lid lock key cylinder switch
- Malfunction of the transmitter
- Malfunction of the ETACS-ECU
- Damaged harness wires or connectors

### DIAGNOSIS

#### Required Special Tools:

- MB991223: Test Harness Set
- MB991502: Scan Tool (MUT-II)
- MB991529: Diagnostic Trouble Code Check Harness

**STEP 1. Check the ETACS-ECU power supply circuit.**

Do all of the following functions work when the ignition switch is turned to the "LOCK" (OFF) position?

- Ignition key reminder tone alarm function
- Light reminder tone alarm function
- Central door locking system
- Hazard warning light
- Interior light dimming function

**Q: Do any of the functions work?**

**YES :** Go to Step 2.

**NO :** Check the ETACS-ECU battery circuit. Refer to Inspection Procedure O-1 (P.54B-266 ).

**STEP 2. Check the "SECURITY" indicator circuit at the ETACS-ECU connector C-81.**

(1) Disconnect the ETACS-ECU connector C-81 and measure at the harness side.

(2) Connect terminal 39 to the ground.

**Q: Does the "SECURITY" indicator light illuminate?**

**YES :** Go to Step 10 <when using scan tool MB991502> or 11 <when using a voltmeter>.

**NO :** Go to Step 3.

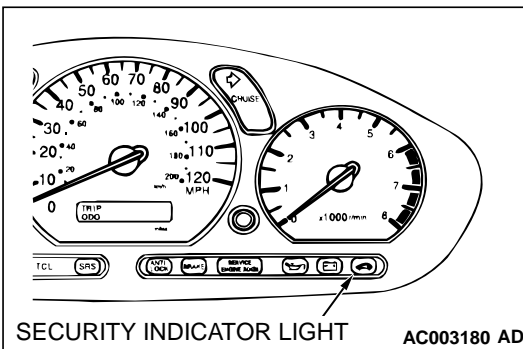
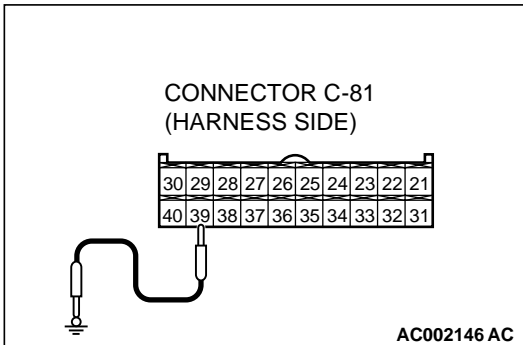

**STEP 3. Check the "SECURITY" indicator light bulb.**

**Q: Is the "SECURITY" indicator light bulb in good condition?**

**YES :** Go to Step 4.

**NO :** Replace it. The security indicator light should illuminate, and the theft-alarm system should be armed normally.

**STEP 4. Check the combination meter (printed-circuit board).**

- (1) Remove the combination meter.
- (2) Remove the seat belt warning light bulb. The measure the resistance between the bulb terminals.
- (3) Install the bulb to the combination meter, and then measure the resistance between connector C-30 terminal 1 and 2. The resistance reading at this time should be muck the same as the resistance measured at Step (2).

**Q: Are the two resistance values extremely different each other?**

**YES :** Repair or replace the combination meter (printed-circuit board). The security indicator light should illuminate, and the theft-alarm system should be armed normally.

**NO :** Go to Step 5.

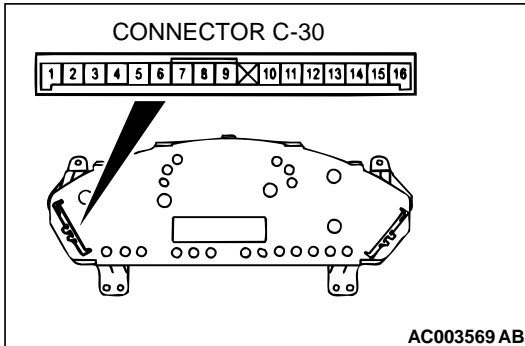

**STEP 5. Check the combination meter power supply circuit at the combination meter connector C-30.**

- (1) Disconnect the combination meter connector C-30 and measure at the harness side.
- (2) Measure the voltage between terminal 1 and ground.

**Q: Is the voltage approximately 12 volts (battery positive voltage)?**

**YES :** Go to Step 8.

**NO :** Go to Step 6.

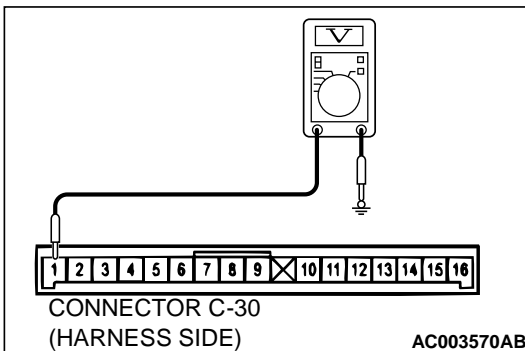

**STEP 6. Check combination meter connector C-30 for damage.**

**Q: Is combination meter connector C-30 in good condition?**

**YES :** Go to Step 7.

**NO :** Repair or replace it. Refer to GROUP 00E, Harness Connector Inspection [P.00E-2](#) . The security indicator light should illuminate, and the theft-alarm system should be armed normally.

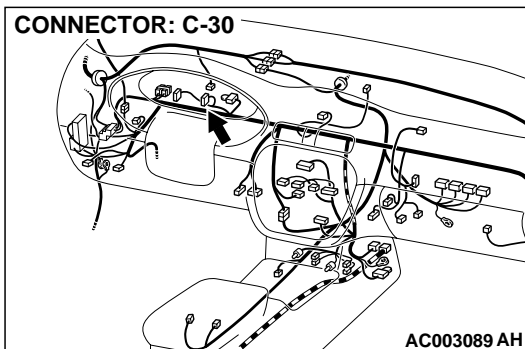



CONNECTORS: C-30, C-57

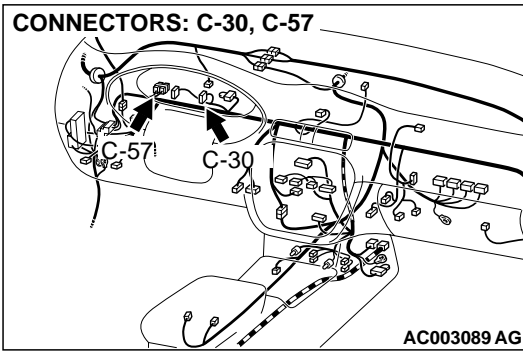

CONNECTOR: C-60

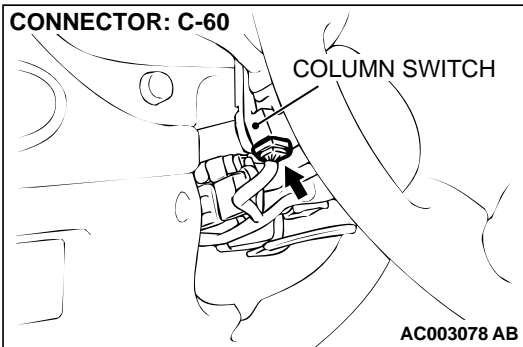

CONNECTOR: C-78  
JUNCTION BLOCK  
(FRONT VIEW)

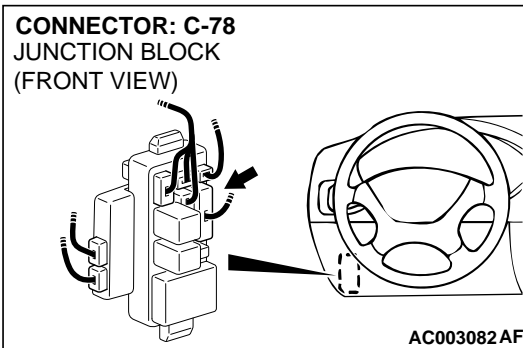

CONNECTOR: C-84  
JUNCTION BLOCK  
(REAR VIEW)

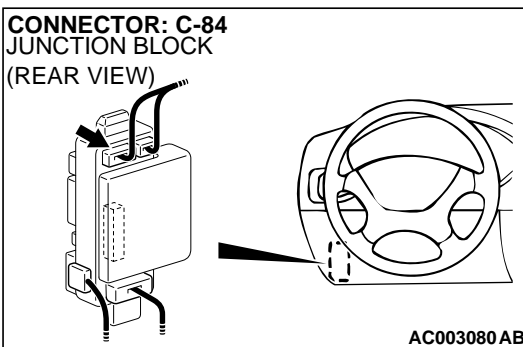

**STEP 7. Check the harness wires between combination meter connector C-30 and battery.**

**NOTE:** After checking junction block connectors C-78 and C-84, joint connector C-57 and intermediate connector C-66, check the wires. If junction block connectors C-78 and C-84, joint connector C-57 and intermediate connector C-66 are damaged, repair or replace them. Refer to GROUP 00E, Harness Connector Inspection [P.00E-2](#).

**Q: Are the harness wires between combination meter connector C-30 and battery in good condition?**

**YES :** There is no action to be taken.

**NO :** Repair or replace them. The security indicator light should illuminate, and the theft-alarm system should be armed normally.

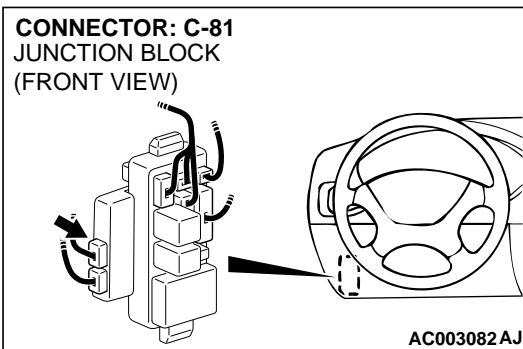
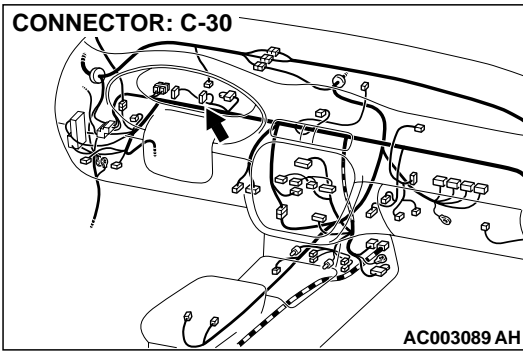

**STEP 8. Check combination meter connector C-30 and ETACS-ECU connector C-81 for damage.**

**Q: Are combination meter connector C-30 and ETACS-ECU connector C-81 in good condition?**

**YES :** Go to Step 9.

**NO :** Repair or replace them. Refer to GROUP 00E, Harness Connector Inspection [P.00E-2](#) . The security indicator light should illuminate, and the theft-alarm system should be armed normally.

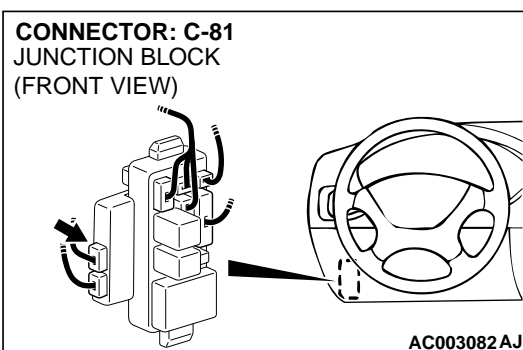
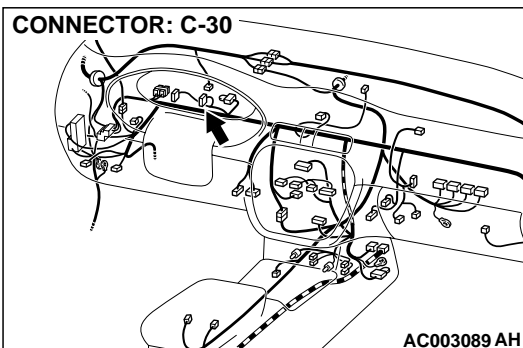

**STEP 9. Check the harness wire between combination meter connector C-30 and ETACS-ECU connector C-81.**

**Q: Is the harness wire between combination meter connector C-30 and ETACS-ECU connector C-81 in good condition?**

**YES :** There is no action to be taken.

**NO :** Repair it. The security indicator light should illuminate, and the theft-alarm system should be armed normally.

**STEP 10. Check the input signal (by using scan tool MB991502).**

Check the input signals from the following switches:

- Ignition key reminder switch
- Driver's and front passenger's switch
- Door switches
- Driver's and front passenger's door key cylinder switch
- Driver's, front passenger's and rear door lock actuator switch
- Hood switch
- Trunk lid latch switch
- Trunk lid lock key cylinder switch
- Transmitter

**⚠ CAUTION**

To prevent damage to scan tool MB991502, always turn the ignition switch to the "LOCK" (OFF) position before connecting or disconnecting scan tool MB991502.

- (1) Connect scan tool MB991502 to the data link connector.
- (2) Check that the tone alarm of scan tool MB991502 sounds when the input signal enters.

**Q: Does the tone alarm of scan tool MB991502 sound when the input signal enters?**

**YES :** Replace the ETACS-ECU. The security indicator light should illuminate, and the theft-alarm system should be armed normally.

**NO :** Check the relevant input signal circuit. Refer to [P.54B-9](#) .

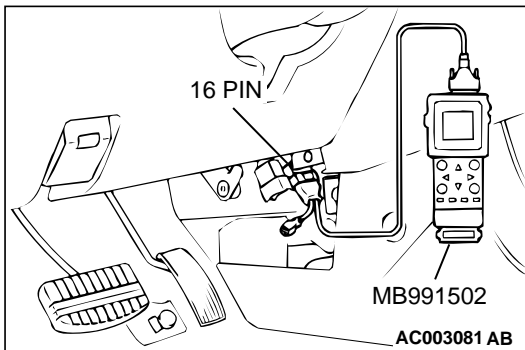

**STEP 11. Check the input signal (by using a voltmeter).**

Check the input signals from the following switches:

- Ignition key reminder switch
- Driver's and front passenger's switch
- Door switches
- Driver's and front passenger's door key cylinder switch
- Driver's, front passenger's and rear door lock actuator switch
- Hood switch
- Trunk lid latch switch
- Trunk lid lock key cylinder switch
- Transmitter

- (1) Use special tool MB991529 to connect a voltmeter between ground terminal 4 or 5 and ETACS-ECU terminal 9 of the data link connector.
- (2) Check that the voltmeter indicator deflects once when the input signal enters.

**Q: Does the voltmeter indicator deflect?**

**YES :** Replace the ETACS-ECU. The security indicator light should illuminate, and the theft-alarm system should be armed normally.

**NO :** Check the relevant input signal circuit. Refer to [P.54B-9](#) .

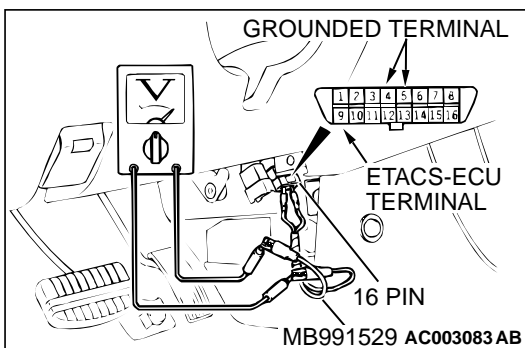

Inspection Procedure M-2: Theft-alarm system: Horn does not sound when the theft-alarm is triggered.

Theft-alarm Horn Circuit

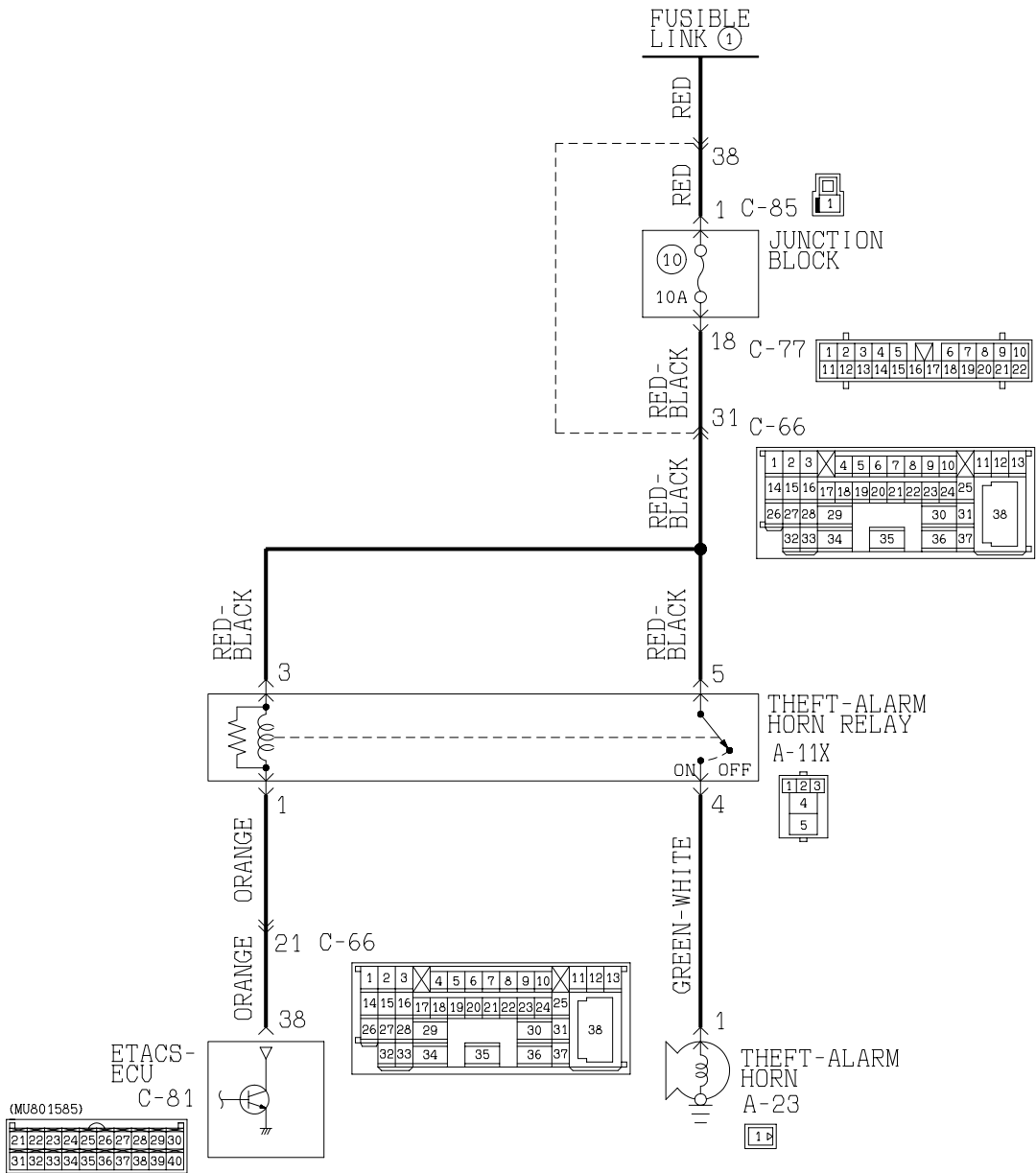

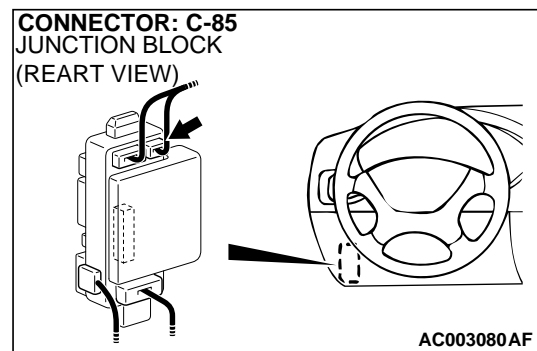
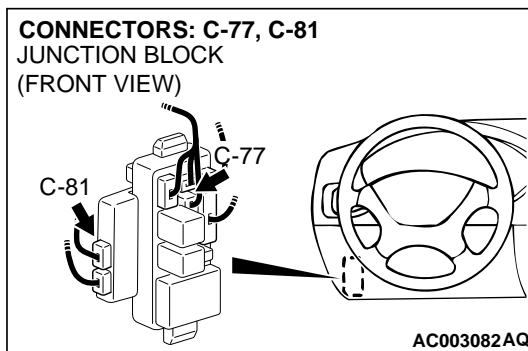
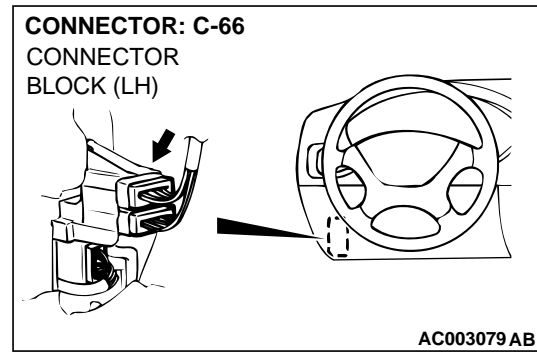
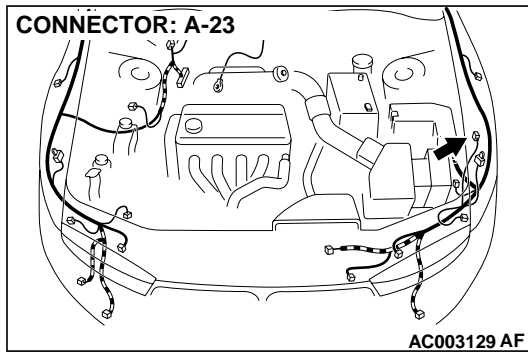
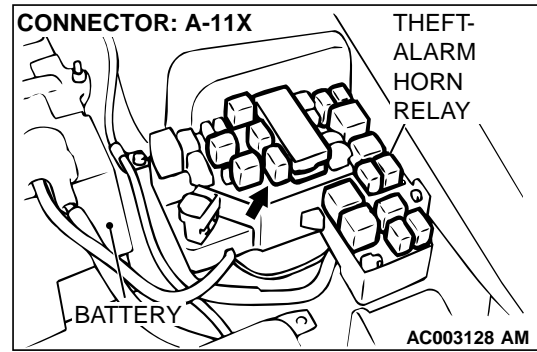
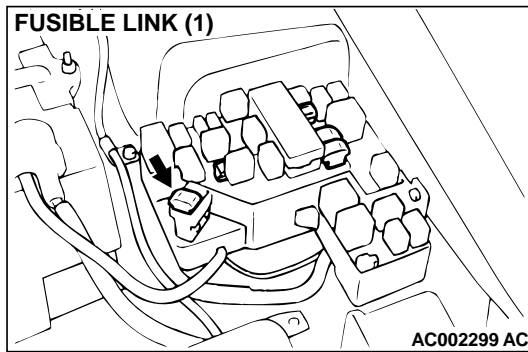

**CIRCUIT OPERATION**

The ETACS-ECU will sound the theft-alarm horn and horn if the theft-alarm system or the keyless entry system answerback is triggered.

**TECHNICAL DESCRIPTION (COMMENT)**

The theft-alarm horn is shared by the keyless entry system. If the theft-alarm horn sounds normally through the keyless entry system answerback, the ETACS-ECU may be defective.

**TROUBLESHOOTING HINTS**

- Malfunction of the theft-alarm horn
- Malfunction of the theft-alarm horn relay
- Malfunction of the ETACS-ECU
- Damaged harness wires or connectors

**DIAGNOSIS**

**Required Special Tool:**

- MB991223: Test Harness Set

**STEP 1. Check the keyless entry system horn answerback.**

Activate the keyless entry system horn answerback. (Refer to GROUP 42, Keyless Entry System – On-vehicle Service – Enabling/disabling the Answerback Function P.42-68.)

**Q: Does the horn answerback function work?**

**YES :** Replace the ETACS-ECU. The horn should sound when the theft-alarm system is triggered.

**NO :** Go to Step 2.

**STEP 2. Check the theft-alarm horn.**

Connect the battery as shown and check that the theft-alarm horn sounds.

**Q: Is the theft-alarm horn in good condition?**

**YES :** Go to Step 3.

**NO :** Replace it. The horn should sound when the theft-alarm system is triggered.

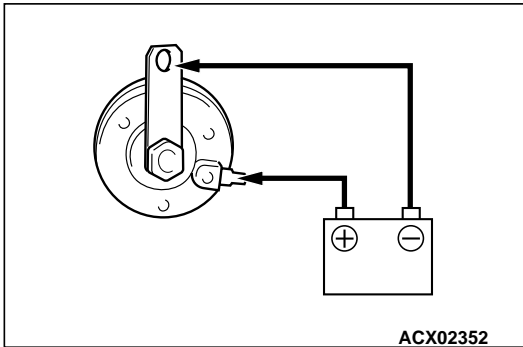

**STEP 3. Check the theft-alarm horn relay.**

BATTERY VOLTAGE	TESTER CONNECTION	SPECIFIED CONDITION
Not applied	1 – 3	Continuity
1 – Battery (+) terminal, 3 – Battery (-) terminal	4 – 5	Continuity

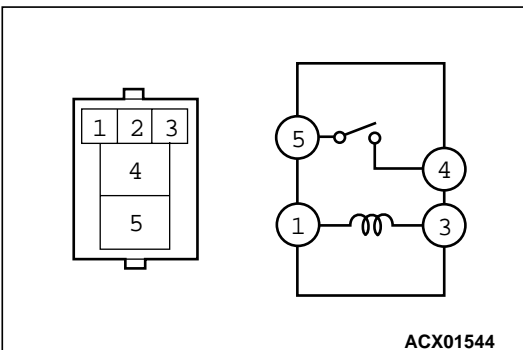

**Q: Is the theft-alarm horn relay in good condition?**

**YES :** Go to Step 4.

**NO :** Replace it. The horn should sound when the theft-alarm system is triggered.

**STEP 4. Check the theft-alarm horn relay power supply circuit at the theft-alarm horn relay connector A-11X.**

(1) Disconnect the theft-alarm horn relay connector A-11X and measure at the relay box side.

(2) Measure the voltages between terminals 3, 5 and ground.

**Q: Are the voltages approximately 12 volts (battery positive voltage)?**

**YES :** Go to Step 7.

**NO :** Go to Step 5.

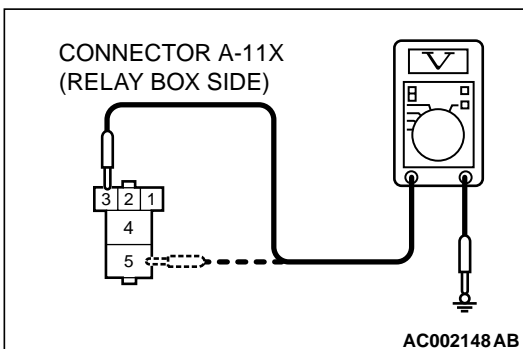

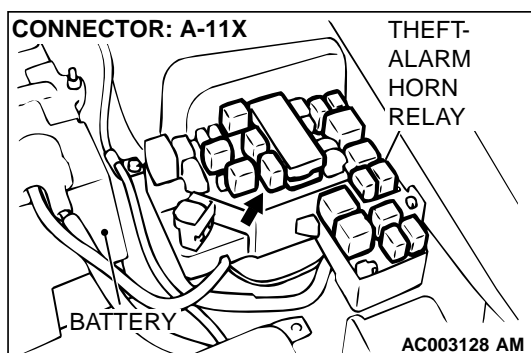

**STEP 5. Check the theft-alarm horn relay connector A-11X for damage.**

**Q: Is theft-alarm horn relay connector A-11X in good condition?**

**YES :** Go to Step 6.

**NO :** Repair or replace it. Refer to GROUP 00E, Harness Connector Inspection [P.00E-2](#) . The horn should sound when the theft-alarm system is triggered.

**STEP 6. Check the harness wires between theft-alarm horn relay connector A-11X and fusible link (1).**

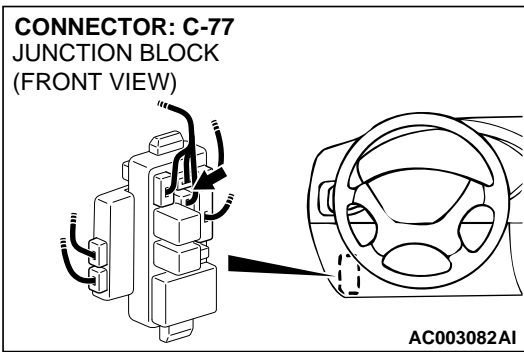
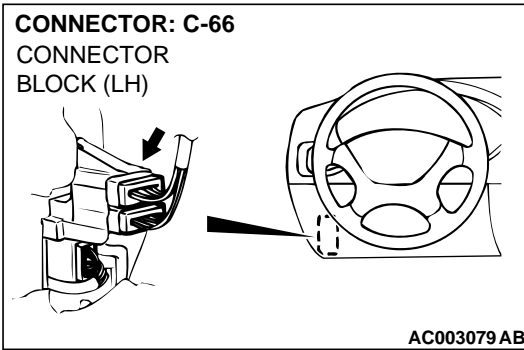
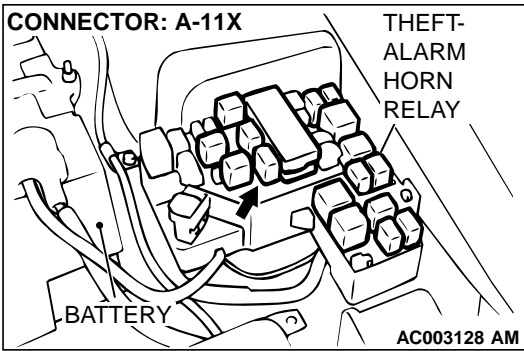
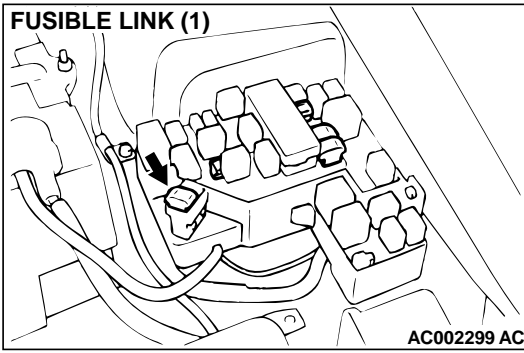



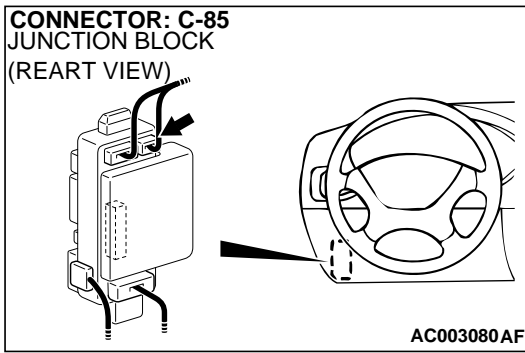

*NOTE: After checking intermediate connector C-66 and junction block connector C-77 and C-85, check the wires. If intermediate connector C-66 and junction block connector C-77 and C-85 are damaged, repair or replace them. Refer to GROUP 00E, Harness Connector Inspection P.00E-2 .*

**Q: Are the harness wire between theft-alarm horn relay connector A-11X and fusible link (1) in good condition?**

**YES :** There is no action to be taken.

**NO :** Repair them. The horn should sound when the theft-alarm system is triggered.

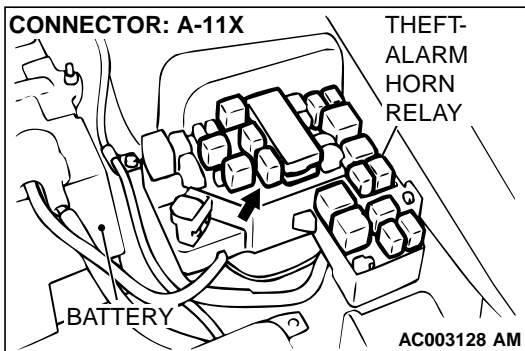

**STEP 7. Check the theft-alarm horn relay connector A-11X and ETACS-ECU connector C-81 for damage.**

**Q: Are theft-alarm horn relay connector A-11X and ETACS-ECU connector C-81 in good condition?**

**YES :** Go to Step 8.

**NO :** Repair or replace them. Refer to GROUP 00E, Harness Connector Inspection P.00E-2 . The horn should sound when the theft-alarm system is triggered.

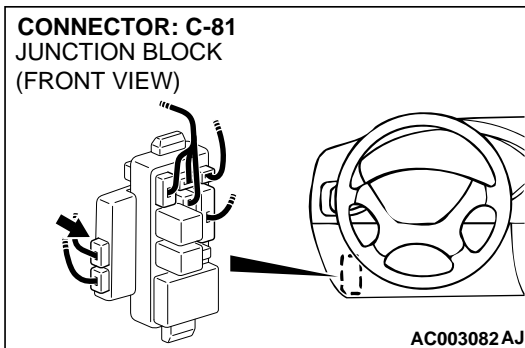

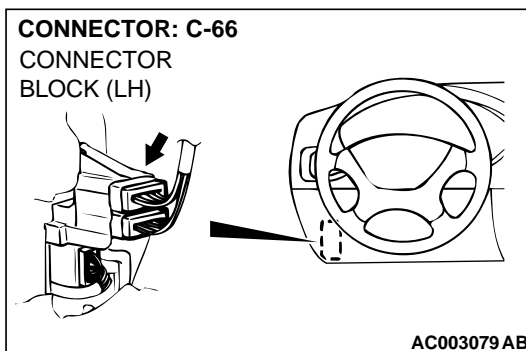
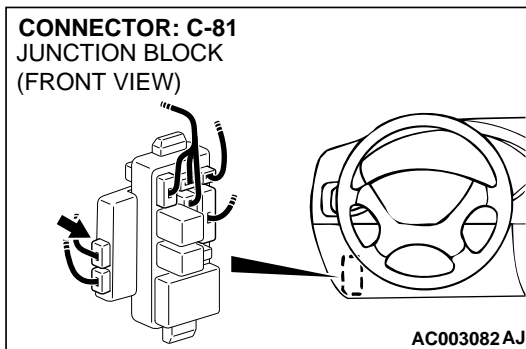
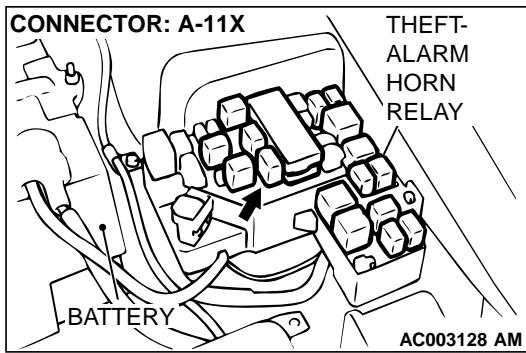

**STEP 8. Check the harness wires between theft-alarm horn relay connector A-11X and ETACS-ECU connector C-81.**

**NOTE:** After checking intermediate connector C-66, check the wires. If intermediate connector C-66 is damaged, repair or replace it. Refer to GROUP 00E, Harness Connector Inspection P.00E-2 .

**Q:** Are the harness wires between theft-alarm horn relay connector A-11X and ETACS-ECU connector C-81 in good condition?

**YES :** Go to Step 9.

**NO :** Repair them. The horn should sound when the theft-alarm system is triggered.

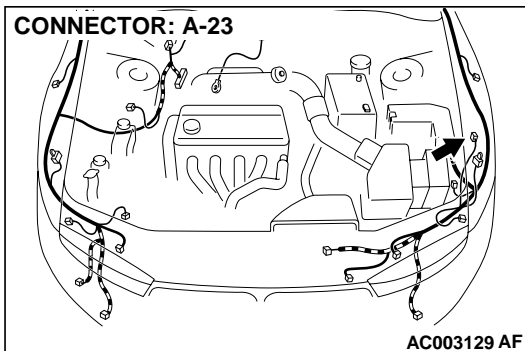
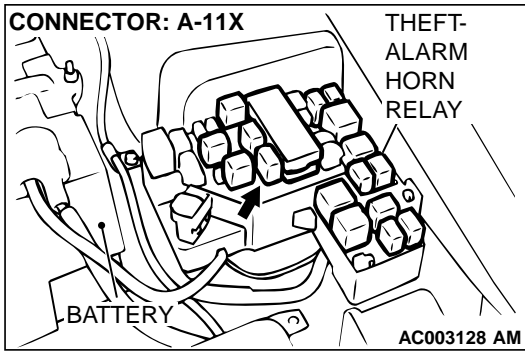

**STEP 9.** Check the theft-alarm horn relay connector A-11X and theft-alarm horn connector A-23 for damage.

**Q:** Are theft-alarm horn relay connector A-11X and theft-alarm horn connector A-23 in good condition?

**YES :** Go to Step 10.

**NO :** Repair or replace them. Refer to GROUP 00E, Harness Connector Inspection [P.00E-2](#) . The horn should sound when the theft-alarm system is triggered.

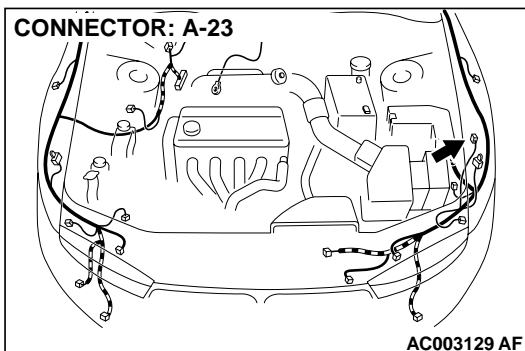
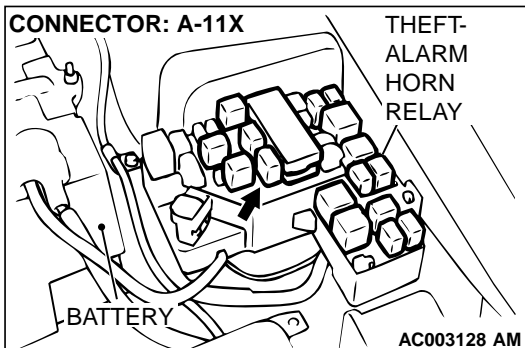

**STEP 10.** Check the harness wire between theft-alarm horn relay connector A-11X and theft-alarm horn connector A-23.

**Q:** Is the harness wire between horn relay connector A-11X and theft-alarm horn connector A-23 in good condition?

**YES :** Go to Step 11.

**NO :** Repair it. The horn should sound when the theft-alarm system is triggered.

**STEP 11. Check that the theft-alarm horn is installed properly.**

*NOTE: The theft-alarm horn is grounded to the body through the installation bolts.*

**Q: Is the theft-alarm horn installation in good condition?**

**YES :** Replace the ETACS-ECU. The horn should sound when the theft-alarm system is triggered.

**NO :** Repair it. The horn should sound when the theft-alarm system is triggered.

**Inspection Procedure M-3: Theft-alarm system: Headlights (high-beam) do not flash when the theft-alarm system is triggered.**

**HEADLIGHTS (HIGH-BEAM) DO NOT FLASH WHEN THE THEFT-ALARM SYSTEM IS TRIGGERED**

If the headlights (high-beam) work normally, the front-ECU or the ETACS-ECU may be defective.

**TROUBLESHOOTING HINTS**

- Malfunction of the front-ECU
- Malfunction of the ETACS-ECU
- Damaged harness wires or connectors

**DIAGNOSIS**

**STEP 1. Check the headlight (high-beam) operation.**

**Q: Do the headlights (high-beam) illuminate normally?**

**YES :** Go to Step 2.

**NO :** Solve the problem first. Refer to [P.54B-128](#).

**STEP 2. Replacement of ECU**

(1) Replace the ETACS-ECU.

(2) The headlights (high-beam) should flash when the theft-alarm system is triggered.

**Q: Do the headlights (high-beam) flash normally by the theft-alarm system?**

**YES :** There is no action to be taken.

**NO :** Replace the front-ECU. The headlights (high-beam) should flash when the theft-alarm system is triggered.

**Inspection Procedure M-4: Theft-alarm system: Panic alarm function does not work.**

**PANIC ALARM FUNCTION DOES NOT WORK**

If the keyless entry system is normal, the ETACS-ECU is defective.

**TROUBLESHOOTING HINTS**

- Malfunction of the ETACS-ECU
- Damaged harness wires or connectors

**DIAGNOSIS**

**Required Special Tools:**

- MB991502: Scan Tool (MUT-II)
- MB991529: Diagnostic Trouble Code Check Harness

**STEP 1. Check the keyless entry system.**

**Q: Does the keyless entry system work normally?**

**YES :** Go to Step 2<when using scan tool MB991502> or 3<when using a voltmeter>.

**NO :** Solve the problem first. Refer to [P.54B-9](#).

**STEP 2. Check the input signal (by using scan tool MB991502).**

Check the input signals from the transmitter "PANIC" switch.

**⚠ CAUTION**

To prevent damage to scan tool MB991502, always turn the ignition switch to the "LOCK" (OFF) position before connecting or disconnecting scan tool MB991502.

- (1) Connect scan tool MB991502 to the data link connector.
- (2) Check that the tone alarm of scan tool MB991502 sounds when the input signal enters.

**Q: Does the tone alarm of scan tool MB991502 sound when the input signal enters?**

**YES :** Replace the ETACS-ECU. The panic alarm should work normally.

**NO :** Check the transmitter input signal circuit. Refer to Inspection Procedure N-17 ([P.54B-265](#)).

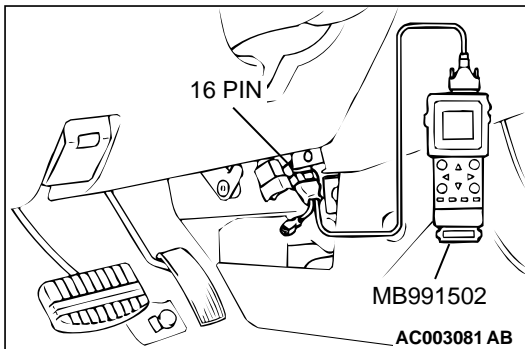

**STEP 3. Check the input signal (by using a voltmeter).**

Check the input signals from the transmitter "PANIC" switch.

- (1) Use special tool MB991529 to connect a voltmeter between ground terminal 4 or 5 and ETACS-ECU terminal 9 of the data link connector.
- (2) Check that the voltmeter indicator deflects once when the input signal enters.

**Q: Does the voltmeter indicator deflect?**

**YES :** Replace the ETACS-ECU. The panic alarm should work normally.

**NO :** Check the transmitter input signal circuit. Refer to Inspection Procedure N-17 ([P.54B-265](#)).

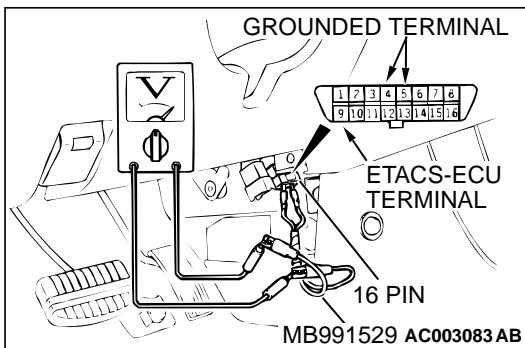

Inspection Procedure N-1: The ignition switch (ACC) signal is not sent to the ETACS-ECU.

Ignition Switch (ACC) Input Circuit

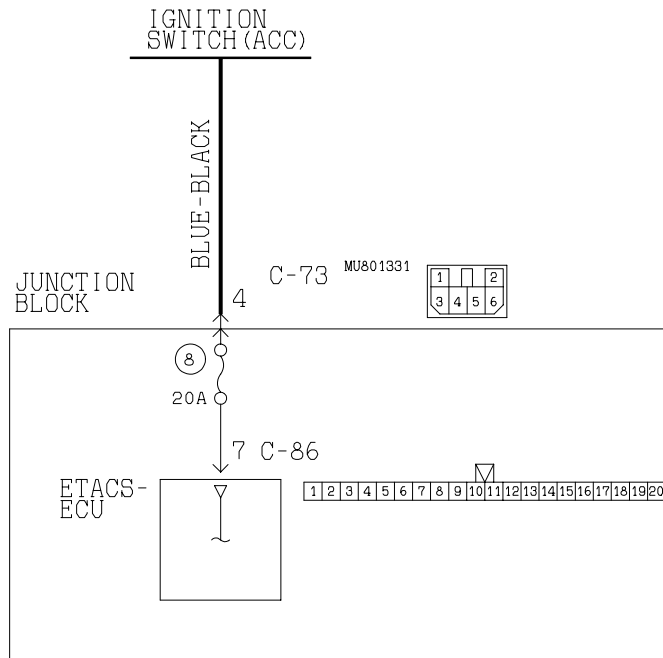

W1S09M21AA

AC004233

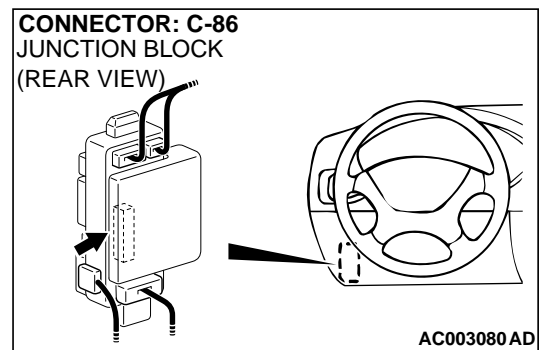
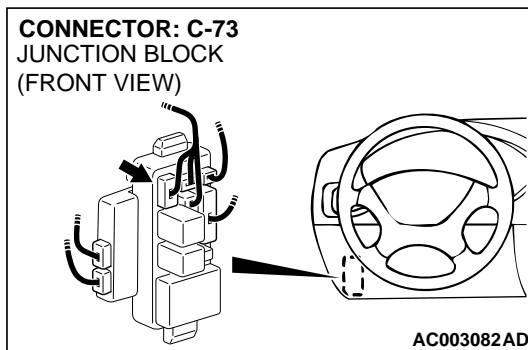

**CIRCUIT OPERATION.**

The ETACS-ECU operates various functions according to the input signal from the ignition switch (ACC).

**TECHNICAL DESCRIPTION (COMMENT)**

The ignition switch (ACC) input signal is used to operate the windshield wiper and washer. If the signal fails, windshield wiper and washer will not work normally.

*NOTE: The windshield wiper and washer works normally if a normal ignition switch (ACC) signal is sent from the ignition switch directly to the front-ECU.*

**TROUBLESHOOTING HINTS**

- Malfunction of the ETACS-ECU
- Damaged harness wires or connectors

**DIAGNOSIS**

**Required Special Tools:**

- MB991223: Test Harness Set

TSB Revision

**STEP 1. Check the ignition switch (ACC) circuit at the ETACS-ECU connector C-86.**

- (1) Disconnect the ETACS-ECU connector C-86 and measure at the junction block side.
- (2) Turn the ignition switch to the "ACC" position.
- (3) Measure the voltage between terminal 7 and ground.

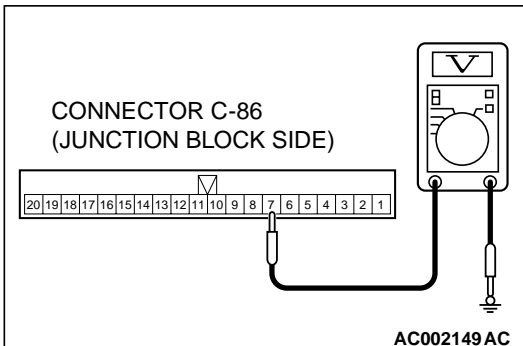

**Q: Is the voltage approximately 12 volts (battery positive voltage)?**

**YES :** Replace the ETACS-ECU. The ignition switch (ACC) input signal should be able to be checked and the windshield wiper and washer should work normally.

**NO :** Go to Step 2.

**STEP 2. Check ETACS-ECU connector C-86 for damage.**

**Q: Is ETACS-ECU connector C-86 in good condition?**

**YES :** Go to Step 3.

**NO :** Repair or replace it. Refer to GROUP 00E, Harness Connector Inspection [P.00E-2](#) . The ignition switch (ACC) input signal should be able to be checked and the windshield wiper and washer should work normally.

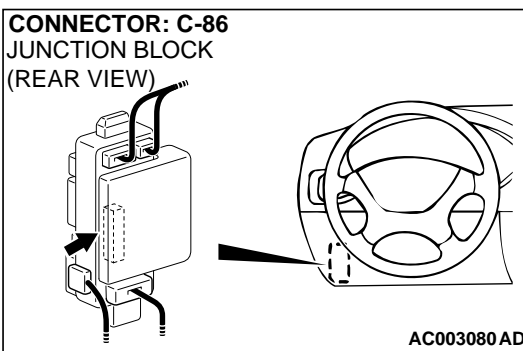

**STEP 3. Check the harness wires between ETACS-ECU connector C-86 and ignition switch (ACC).**

**NOTE:** After checking junction block connector C-73, check the wires. If junction block connector C-73 is damaged, repair or replace it. Refer to GROUP 00E, Harness Connector Inspection [P.00E-2](#) .

**Q: Are the harness wires between ETACS-ECU connector C-86 and ignition switch (ACC) in good condition?**

**YES :** There is no action to be taken.

**NO :** Repair them. The ignition switch (ACC) input signal should be able to be checked and the windshield wiper and washer should work normally.

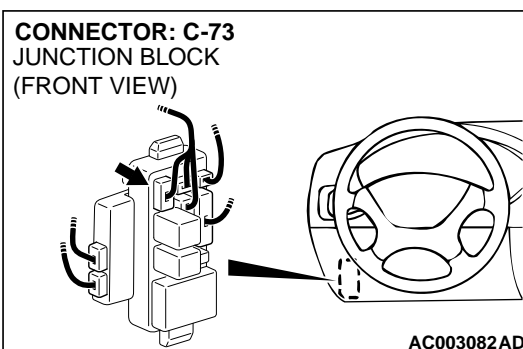
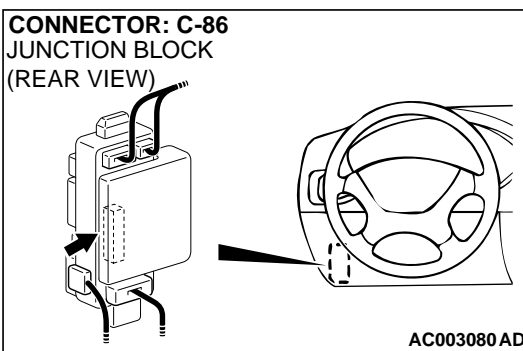

Inspection Procedure N-2: The ignition switch (IG1) signal is not sent to the ETACS-ECU.

Ignition Switch (IG1) Input Circuit

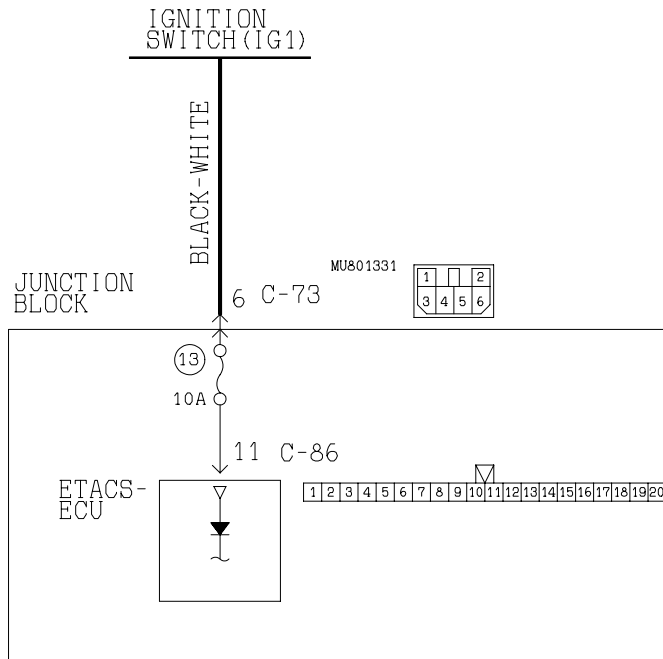

W1S09M22AA  
AC004234

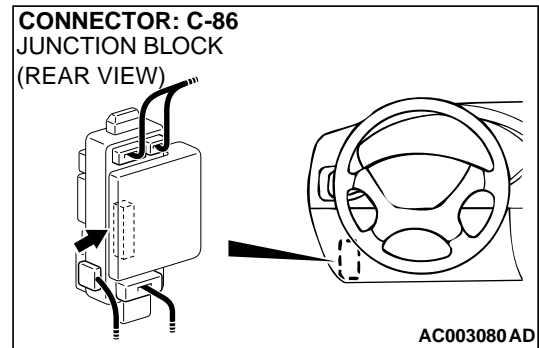
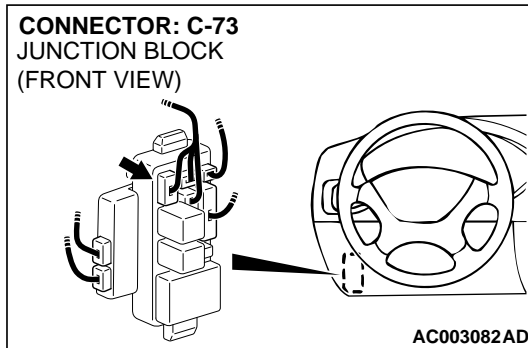

**CURCUIT OPERATION**

- The ETACS-ECU operates various functions according to the input signal from the ignition switch (IG1).
- This circuit will work as a backup circuit if the battery circuit to the ETACS-ECU is open circuit.

**TECHNICAL DESCRIPTION (COMMENT)**

The ignition switch (IG1) input signal is used to operate the following devices or functions:

- Ignition key reminder tone alarm function
- Light reminder tone alarm function
- Seat belt tone alarm function

- Power window timer function
- Seat belt warning light
- Ignition key hole illumination light
- Headlight automatic shutdown function
- Turn-signal light
- Dome light dimming function

**TROUBLESHOOTING HINTS**

- Malfunction of the ETACS-ECU
  - Damaged harness wires or connectors
- If the signal fails, these devices will not work normally.

**DIAGNOSIS**

**Required Special Tools:**

- MB991223: Test Harness Set

TSB Revision



**STEP 1. Check the ignition switch (IG1) circuit at the ETACS-ECU connector C-86.**

- (1) Disconnect the ETACS-ECU connector C-86 and measure at the junction block side.
- (2) Turn the ignition switch to the "ON" position.
- (3) Measure the voltage between terminal 11 and ground.

**Q: Is the voltage approximately 12 volts (battery positive voltage)?**

**YES :** Replace the ETACS-ECU. The ignition switch (IG1) input signal should be able to be checked and the functions, which are described in the "Technical Description (comment)," should work normally.

**NO :** Go to Step 2.

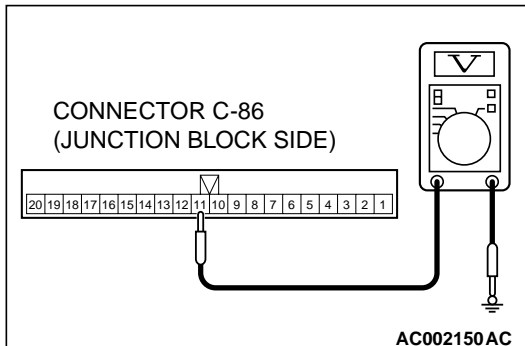

**STEP 2. Check ETACS-ECU connector C-86 for damage.**

**Q: Is ETACS-ECU connector C-86 in good condition?**

**YES :** Go to Step 3.

**NO :** Repair or replace it. Refer to GROUP 00E, Harness Connector Inspection [P.00E-2](#) . The ignition switch (IG1) input signal should be able to be checked and the functions, which are described in the "Technical Description (comment)," should work normally.

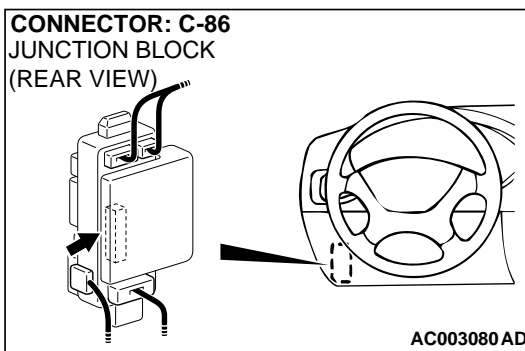

**STEP 3. Check the harness wires between ETACS-ECU connector C-86 and ignition switch (IG1).**

**NOTE:** After checking junction block connector C-73, check the wires. If junction block connector C-73 is damaged, repair or replace it. Refer to GROUP 00E, Harness Connector Inspection [P.00E-2](#) .

**Q: Are the harness wires between ETACS-ECU connector C-86 and ignition switch (IG1) in good condition?**

**YES :** There is no action to be taken.

**NO :** Repair them. The ignition switch (IG1) input signal should be able to be checked and the functions, which are described in the "Technical Description (comment)," should work normally.

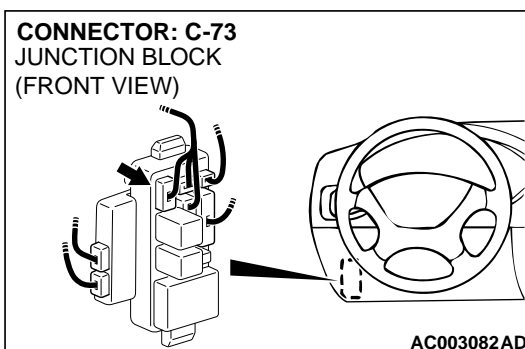
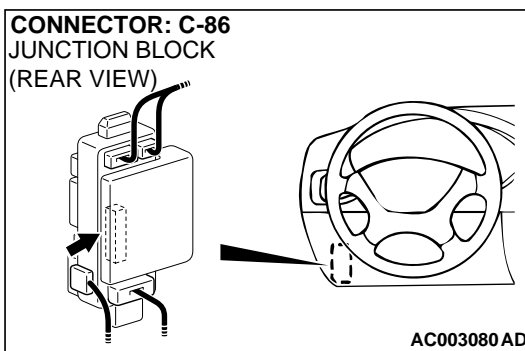

**Inspection Procedure N-3: The key reminder switch signal is not sent to the ETACS-ECU.**

**Key Reminder Switch Input Circuit**

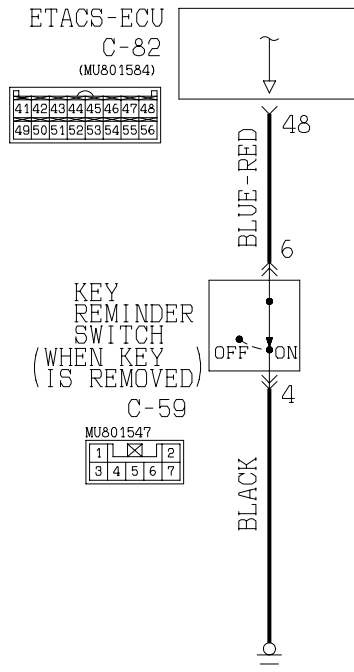

W1S09M23AA

AC004235

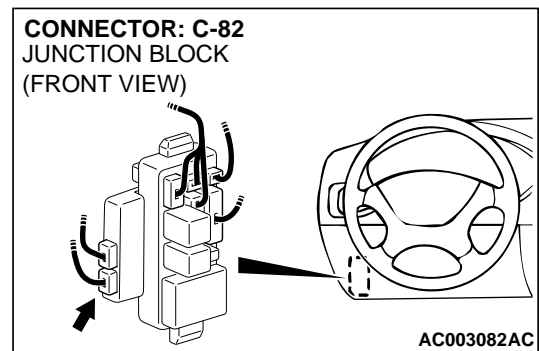
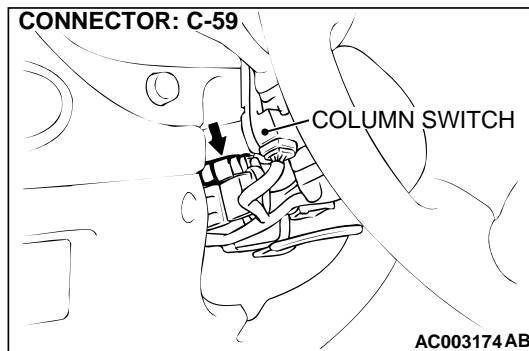

**THE KEY REMINDER SWITCH SIGNAL IS NOT SENT TO THE ETACS-ECU.**

The ETACS-ECU operates various functions according to the input signal from the key reminder switch.

**TECHNICAL DESCRIPTION (COMMENT)**

The key reminder switch input signal is used to operate the following functions or system:

- Ignition key reminder tone alarm function
- Forgotten key prevention function
- Keyless entry system <vehicles with keyless entry system>

- Ignition key hole illumination light
- Dome light dimming function
- Theft-alarm system <vehicles with theft-alarm system>

**TROUBLESHOOTING HINTS**

- Malfunction of the key reminder switch
- Malfunction of the ETACS-ECU
- Damaged harness wires or connectors

If the signal fails, these devices will not work normally.

**DIAGNOSIS**

**Required Special Tools:**

- MB991223: Test Harness Set

TSB Revision

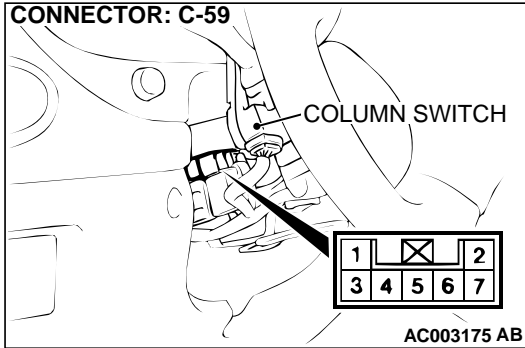

**STEP 1. Check the key reminder switch.**

Disconnect key reminder switch connector C-59. Then check the continuity.

IGNITION KEY	TESTER CONNECTION	SPECIFIED CONDITION
Removed	–	No continuity
Installed	4 – 6	Continuity

**Q: Is the key reminder switch in good condition?**

**YES :** Go to Step 2.

**NO :** Repair it. The key reminder switch input signal should be able to be checked and the functions, which are described in the "Technical Description (comment)," should work normally.

**STEP 2. Check the key reminder switch ground circuit at the key reminder switch connector C-59.**

- (1) Disconnect the key reminder switch connector C-59 and measure at the harness side.
- (2) Measure the resistance between terminal 4 and ground.

**Q: Is the resistance less than 2 ohm?**

**YES :** Go to Step 5.

**NO :** Go to Step 3.

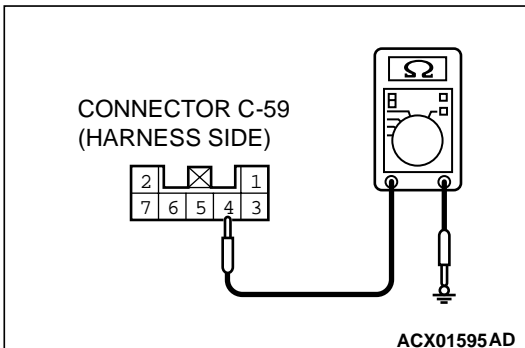

**STEP 3. Check key reminder switch connector C-59 for damage.**

**Q: Is key reminder switch connector C-59 in good condition?**

**YES :** Go to Step 4.

**NO :** Repair or replace it. Refer to GROUP 00E, Harness Connector Inspection [P.00E-2](#) . The key reminder switch input signal should be able to be checked and the functions, which are described in the "Technical Description (comment)," should work normally.

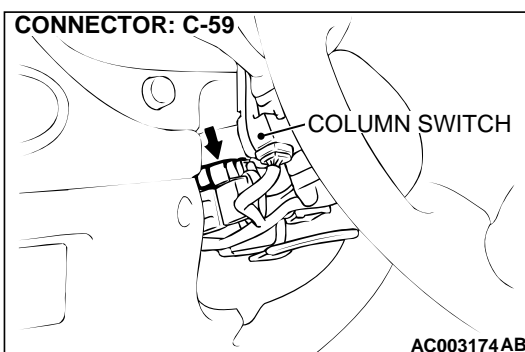

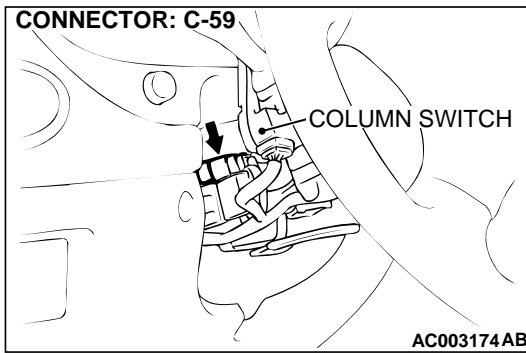

**STEP 4. Check the harness wire between key reminder switch connector C-59 and ground.**

**Q: Is the harness wires between key reminder switch connector C-59 and ground in good condition?**

**YES :** There is no action to be taken.

**NO :** Repair them. The key reminder switch input signal should be able to be checked and the functions, which are described in the "Technical Description (comment)," should work normally.

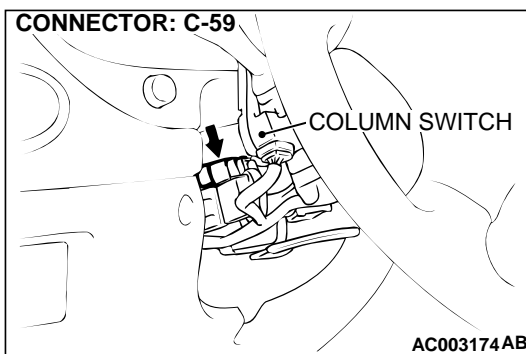

**STEP 5. Check key reminder switch connector C-59 and ETACS-ECU connector C-82 for damage.**

**Q: Are key reminder switch connector C-59 and ETACS-ECU connector C-82 in good condition?**

**YES :** Go to Step 6.

**NO :** Repair or replace them. Refer to GROUP 00E, Harness Connector Inspection [P.00E-2](#) . The key reminder switch input signal should be able to be checked and the functions, which are described in the "Technical Description (comment)," should work normally.

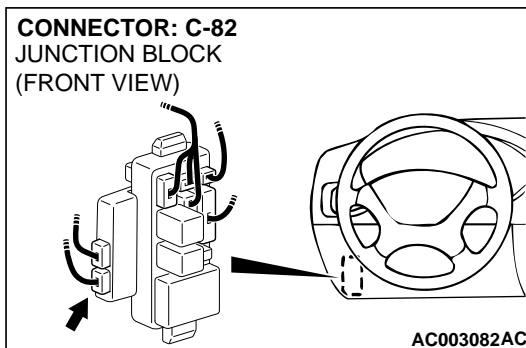

**STEP 6. Check the harness wire between key reminder switch connector C-59 and ETACS-ECU connector C-82.**

**Q: Is the harness wire between key reminder switch connector C-59 and ETACS-ECU connector C-82 in good condition?**

- YES :** Replace the ETACS-ECU. The key reminder switch input signal should be able to be checked and the functions, which are described in the "Technical Description (comment)," should work normally.
- NO :** Repair it. The key reminder switch input signal should be able to be checked and the functions, which are described in the "Technical Description (comment)," should work normally.

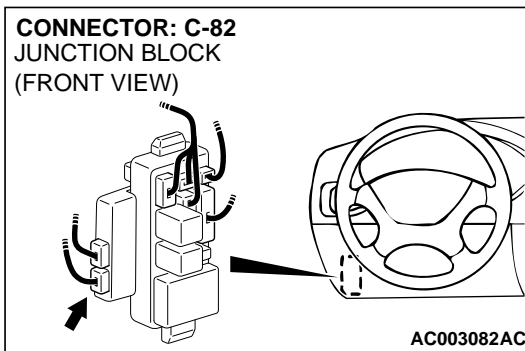
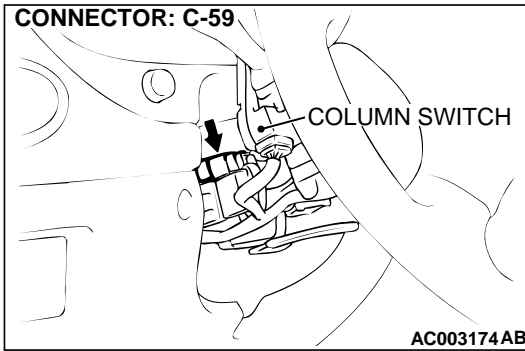

**Inspection Procedure N-4: The hazard warning light switch signal is not sent to the ETACS-ECU.**

**Hazard Warning Light Switch Input Circuit**

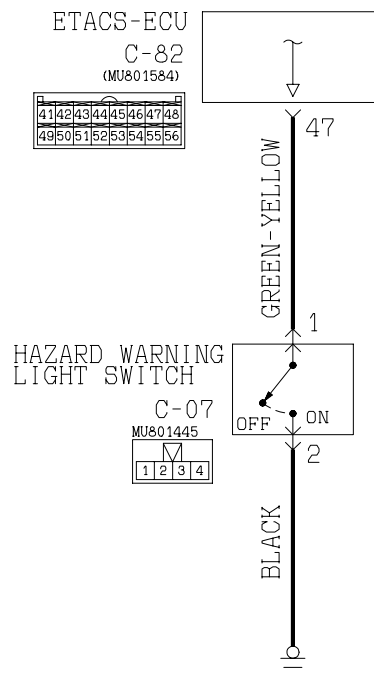

W1S09M24AA

AC004236

TSB Revision

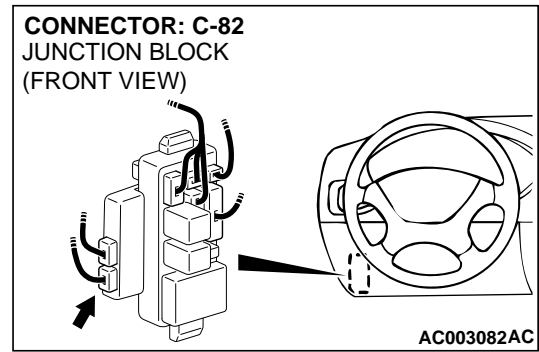
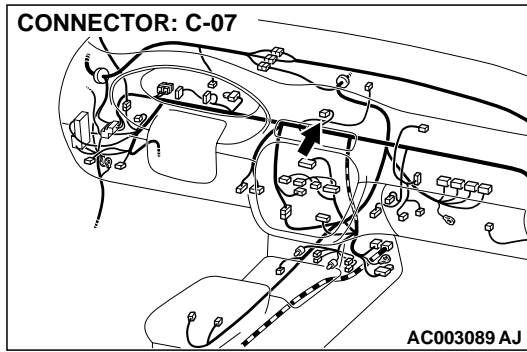

**CIRCUIT OPERATION**

The ETACS-ECU operates various functions according to the input signal from the hazard warning light switch.

**TECHNICAL DESCRIPTION (COMMENT)**

Hazard warning light switch input signal is used to operate the following device or system:

- Hazard warning light

- Keyless entry system (registering the encrypted code)

If the signal fails, these devices will not work normally.

**TROUBLESHOOTING HINTS**

- Malfunction of the hazard warning light switch
- Malfunction of the ETACS-ECU
- Damaged harness wires or connectors

**DIAGNOSIS**

**Required Special Tools:**

- MB991223: Test Harness Set
- MB991502: Scan Tool (MUT-II)
- MB991529: Diagnostic Trouble Code Check Harness

**STEP 1. Check the hazard warning light switch.**

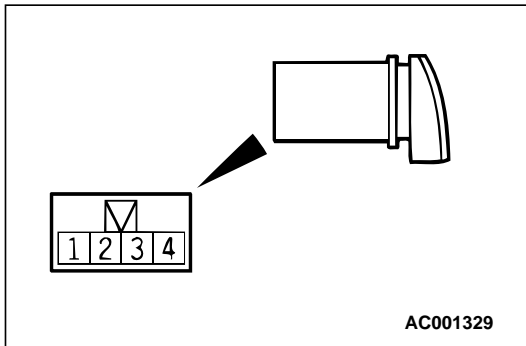

SWITCH POSITION	TESTER CONNECTION	SPECIFIED CONDITION
Released	–	No continuity
Pressed	1 – 2	Continuity

**Q: Is the hazard warning light switch in good condition?**

**YES :** Go to Step 2.

**NO :** Repair it. The hazard warning light switch input signal should be able to be checked and the functions, which are described in the "Technical Description (comment)," should work normally.

**STEP 2. Check the hazard warning light switch ground circuit at the hazard warning light switch connector C-07.**

- (1) Disconnect the hazard warning light switch connector C-07 and measure at the harness side.
- (2) Measure the resistance between terminal 2 and ground.

**Q: Is the resistance less than 2 ohm?**

**YES :** Go to Step 5.

**NO :** Go to Step 3.

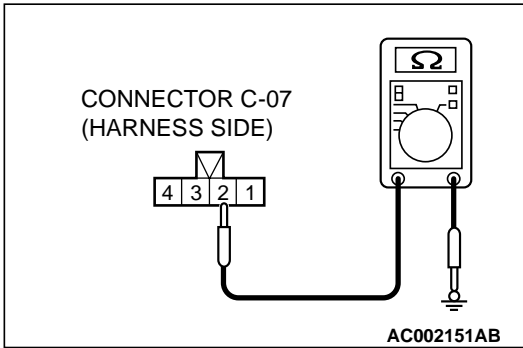

**STEP 3. Check hazard warning light switch connector C-07 for damage.**

**Q: Is hazard warning light switch connector C-07 in good condition?**

**YES :** Go to Step 4.

**NO :** Repair or replace it. Refer to GROUP 00E, Harness Connector Inspection [P.00E-2](#) . The hazard warning light switch input signal should be able to be checked and the functions, which are described in the "Technical Description (comment)," should work normally.

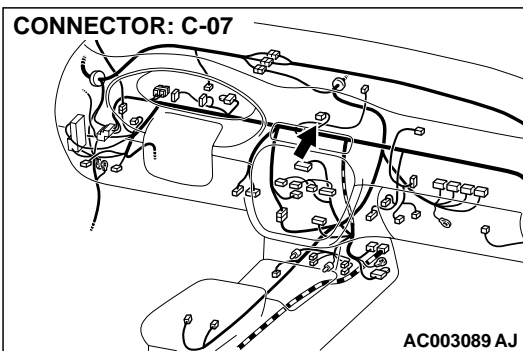

**STEP 4. Check the harness wire between hazard warning light switch connector C-07 and ground.**

**Q: Is the harness wire between hazard warning light switch connector C-07 and ground in good condition?**

**YES :** There is no action to be taken.

**NO :** Repair it. The hazard warning light switch input signal should be able to be checked and the functions, which are described in the "Technical Description (comment)," should work normally.

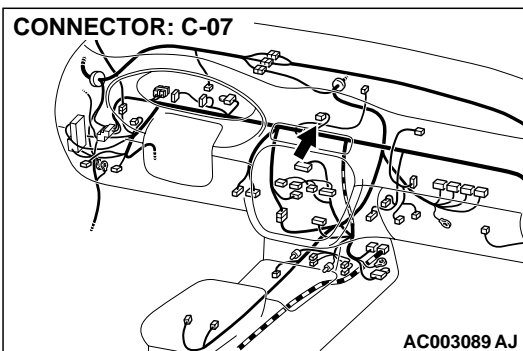

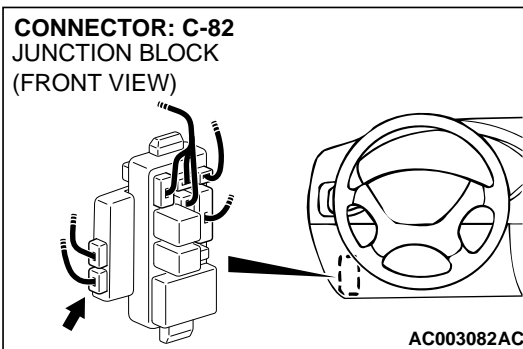
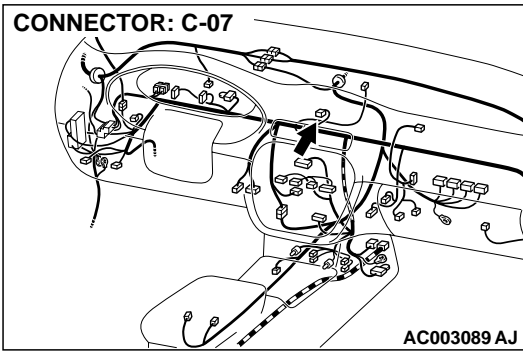

**STEP 5. Check the hazard warning light switch connector C-07 and ETACS-ECU connector C-82 for damage.**

**Q: Are hazard warning light switch connector C-07 and ETACS-ECU connector C-82 in good condition?**

**YES :** Go to Step 6.

**NO :** Repair or replace them. Refer to GROUP 00E, Harness Connector Inspection [P.00E-2](#) . The hazard warning light switch input signal should be able to be checked and the functions, which are described in the "Technical Description (comment)," should work normally.

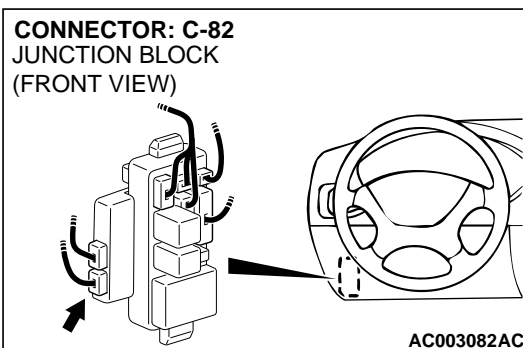
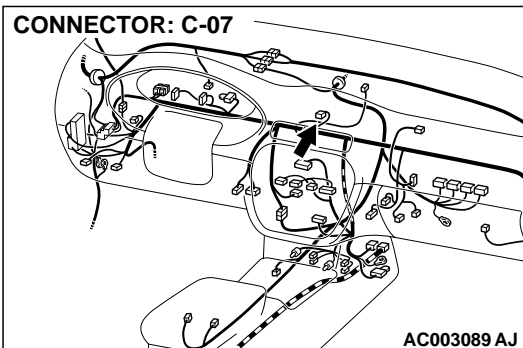

**STEP 6. Check the harness wire between hazard warning light switch connector C-07 and ETACS-ECU connector C-82.**

**Q: Is the harness wire between hazard warning light switch connector C-07 and ETACS-ECU connector C-82 in good condition?**

**YES :** Replace the ETACS-ECU. The hazard warning light switch input signal should be able to be checked and the functions, which are described in the "Technical Description (comment)," should work normally.

**NO :** Repair it. The hazard warning light switch input signal should be able to be checked and the functions, which are described in the "Technical Description (comment)," should work normally.



**Inspection Procedure N-5: The fog light switch signal is not sent to the ETACS-ECU.**

**Fog Light Switch Input Circuit**

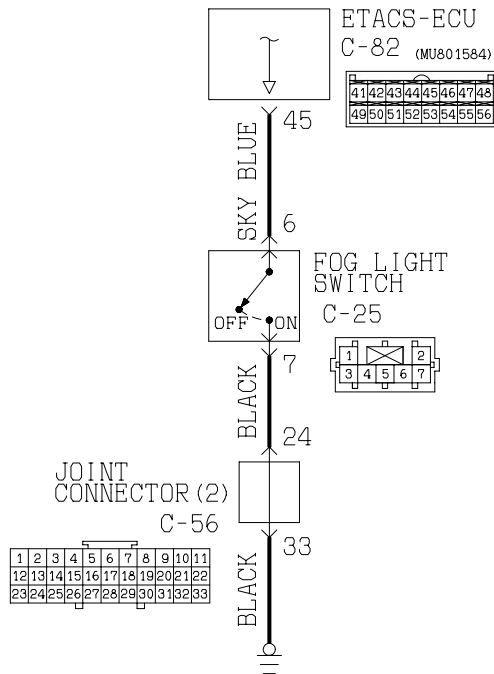

W1S09M25AA  
AC004237

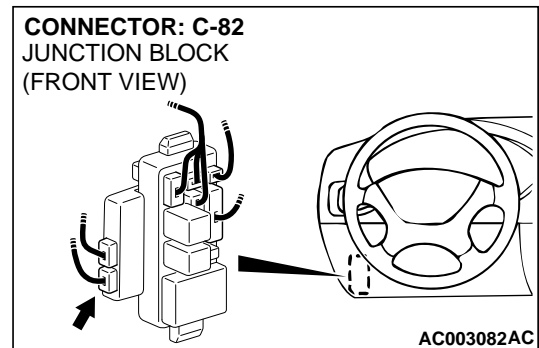
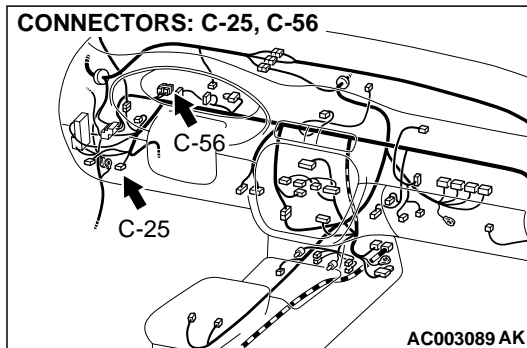

**CIRCUIT OPERATION**

The ETACS-ECU operates the fog lights according to the input signal from the fog light switch.

**TECHNICAL DESCRIPTION (COMMENT)**

The fog lights will not work normally if the fog light switch input signal is an error.

**TROUBLESHOOTING HINTS**

- Malfunction of the fog light switch
- Malfunction of the ETACS-ECU
- Damaged harness wires or connectors

**DIAGNOSIS**

**Required Special Tools:**

- MB991223: Test Harness Set

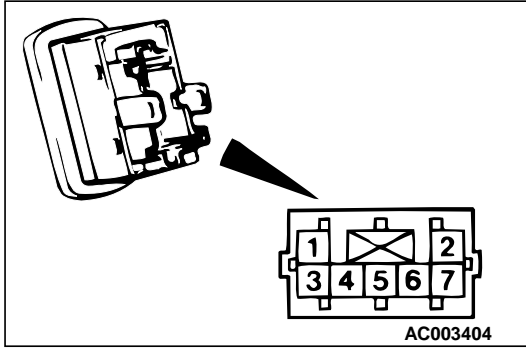
**STEP 1. Check the fog light switch.**

SWITCH POSITION	TESTER CONNECTION	SPECIFIED CONDITION
Released	–	No continuity
Pressed	6 – 7	Continuity

**Q: Is the fog light switch in good condition?****YES** : Go to Step 2.**NO** : Repair it. The fog light switch input signal should be able to be checked and the fog lights should work normally.**STEP 2. Check the fog light switch ground circuit at the fog light switch connector C-25.**

(1) Disconnect the fog light switch connector C-25 and measure at the harness side.

(2) Measure the resistance between terminal 7 and ground.

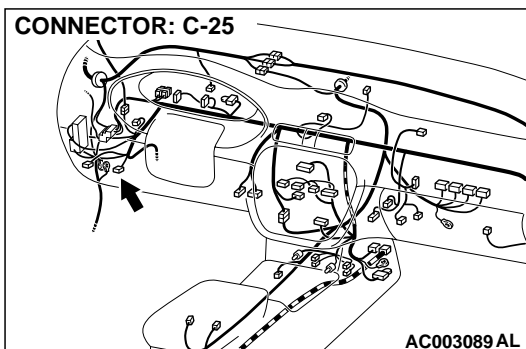
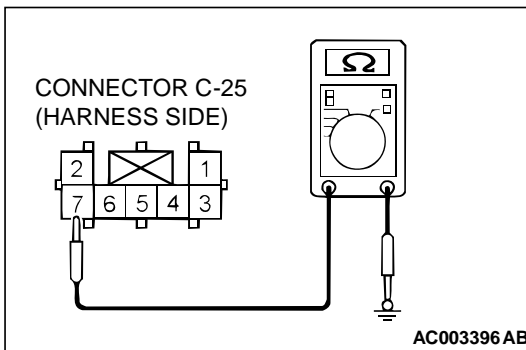
**Q: Is the resistance less than 2 ohm?****YES** : Go to Step 5.**NO** : Go to Step 3.**STEP 3. Check fog light switch connector C-25 for damage.****Q: Is fog light switch connector C-25 in good condition?****YES** : Go to Step 4.**NO** : Repair or replace it. Refer to GROUP 00E, Harness Connector Inspection [P.00E-2](#) . The fog light switch input signal should be able to be checked and the fog light should work normally.

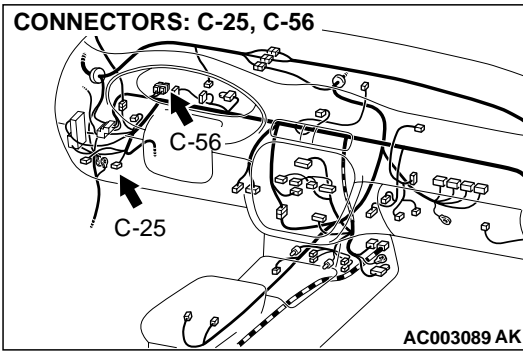

**STEP 4. Check the harness wires between fog light switch connector C-25 and ground.**

*NOTE: After checking joint connector C-56, check the wires. If joint connector C-56 is damaged, repair or replace it. Refer to GROUP 00E, Harness Connector Inspection P.00E-2 .*

**Q: Are the harness wires between fog light switch connector C-25 and ground in good condition?**

**YES :** There is no action to be taken.

**NO :** Repair them. The fog light switch input signal should be able to be checked and the fog lights should work normally.

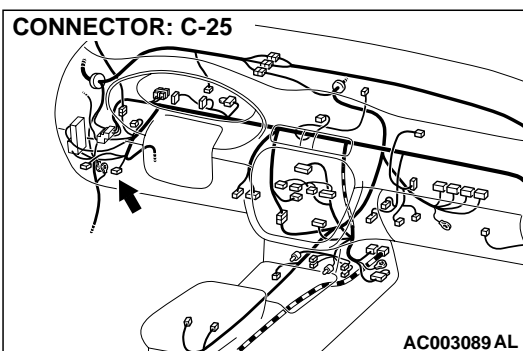

**STEP 5. Check fog light switch connector C-25 and ETACS-ECU connector C-82 for damage.**

**Q: Are fog light switch connector C-25 and ETACS-ECU connector C-82 in good condition?**

**YES :** Go to Step 6.

**NO :** Repair or replace them. Refer to GROUP 00E, Harness Connector Inspection P.00E-2 . The fog light switch input signal should be able to be checked and the fog lights should work normally.

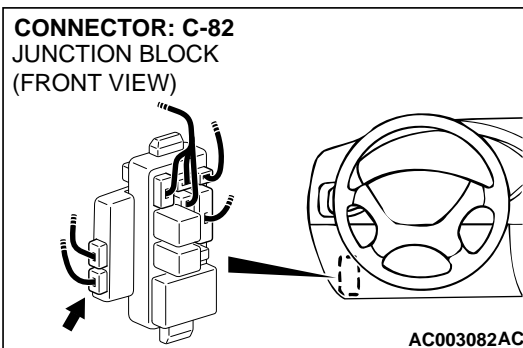

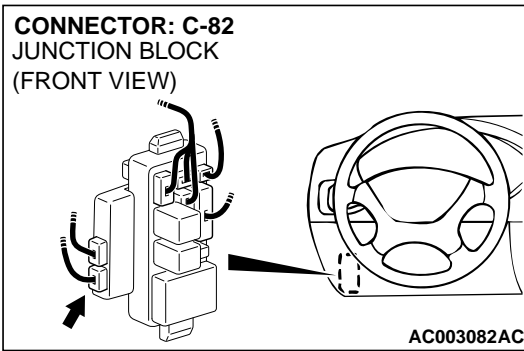
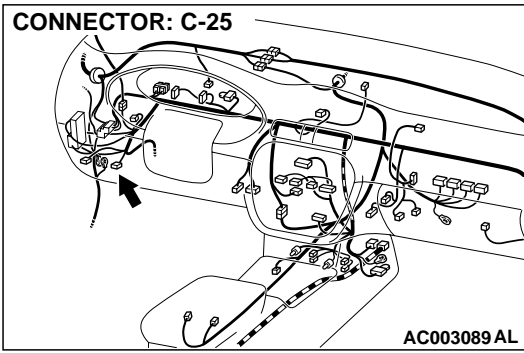

**STEP 6. Check the harness wire between fog light switch connector C-25 and ETACS-ECU connector C-82.**

**Q: Is the harness wire between fog light switch connector C-25 and ETACS-ECU connector C-82 in good condition?**

**YES :** Replace the ETACS-ECU. The fog light switch input signal should be able to be checked and the fog lights should work normally.

**NO :** Repair it. The fog light switch input signal should be able to be checked and the fog lights should work normally.

**Inspection Procedure N-6: The driver's seat belt switch is not sent to the ETACS-ECU.**

**Driver's Seat Belt Switch input Circuit**

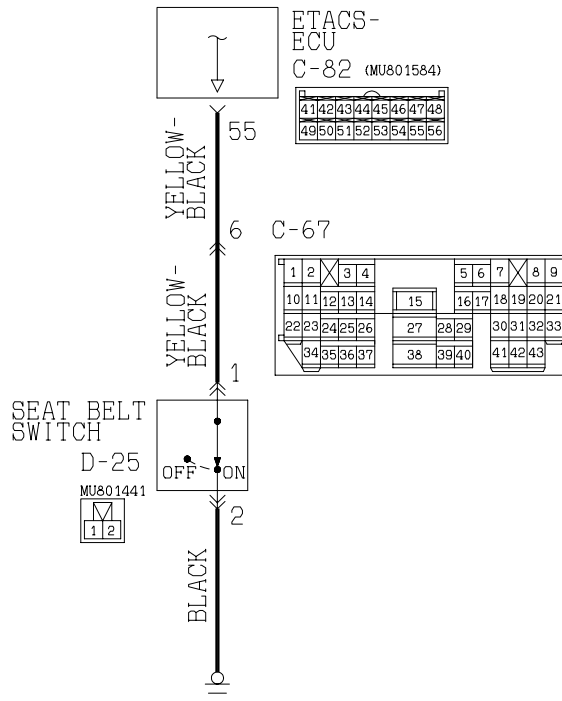

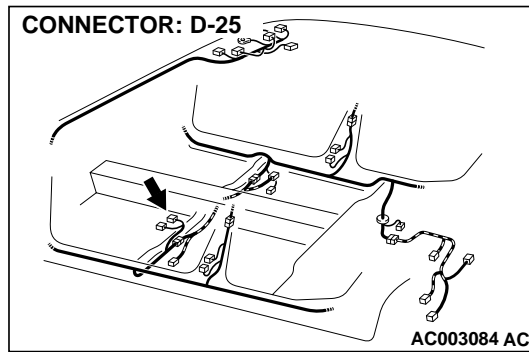
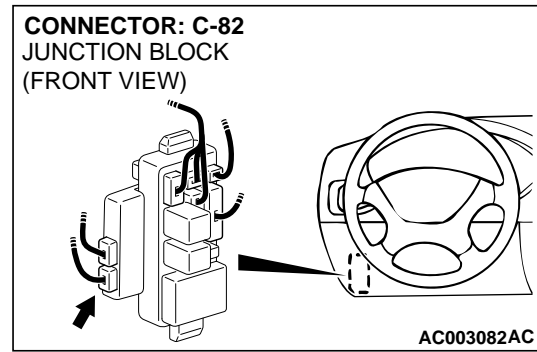
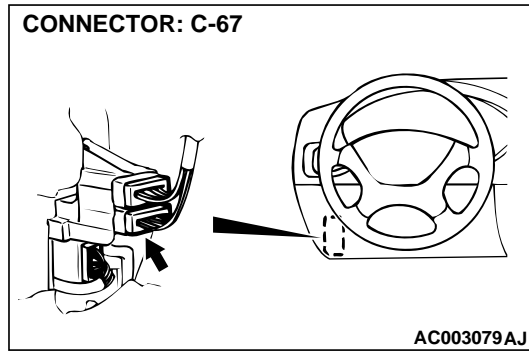

### CIRCUIT OPERATION

The ETACS-ECU operates various functions according to the input signals from the driver's seat belt switch.

### TECHNICAL DESCRIPTION (COMMENT)

The driver's seat belt switch input signal is used to operate the following functions; seat belt tone alarm function, seat belt warning light. If the input signal is an error, these functions will not work normally.

### TROUBLESHOOTING HINTS

- Malfunction of the driver's inner seat belt (driver's seat belt switch)
- Malfunction of the ETACS-ECU
- Damaged harness wires or connectors

### DIAGNOSIS

#### Required Special Tools:

- MB991223: Test Harness Set
- MB991502: Scan Tool (MUT-II)
- MB991529: Diagnostic Trouble Code Check Harness

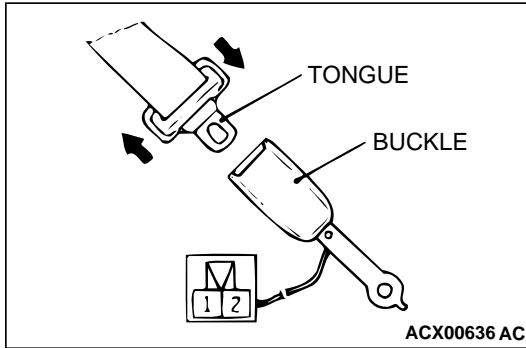

**STEP 1. Check the driver's seat belt switch.**

ITEM	TESTER CONNECTION	SPECIFIED CONDITION
Fastened seat belt	–	No continuity
Unfastened seat belt	1 – 2	Continuity

**Q: Is the driver's seat belt switch in good condition?**

**YES :** Go to Step 2.

**NO :** Replace the driver's inner seat belt. The driver's seat belt switch input signal should be able to be checked and the functions, which are described in the "Technical Description (comment)," should work normally.

**STEP 2. Check the driver's seat belt switch ground circuit at driver's seat belt switch connector D-25.**

- (1) Disconnect driver's seat belt switch connector D-25 and measure at the harness side.
- (2) Measure the resistance between terminal 2 and ground.

**Q: Is the resistance less than 2 ohm?**

**YES :** Go to Step 5.

**NO :** Go to Step 3.

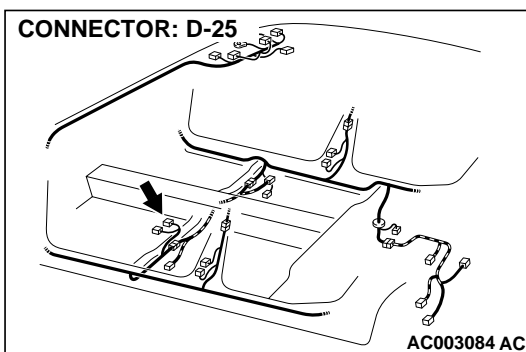
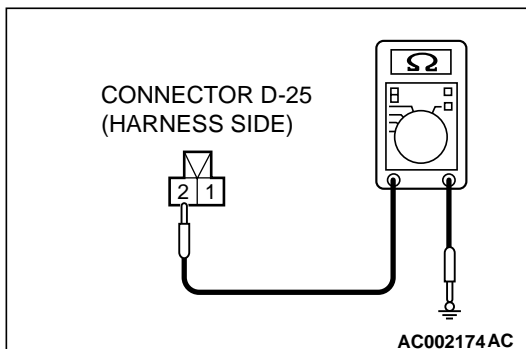

**STEP 3. Check driver's seat belt switch connector D-25 for damage.**

**Q: Is driver's seat belt switch connector D-25 in good condition?**

**YES :** Go to Step 4.

**NO :** Repair or replace it. Refer to GROUP 00E, Harness Connector Inspection [P.00E-2](#) . The driver's seat belt switch input signal should be able to be checked and the functions, which are described in the "Technical Description (comment)," should work normally.

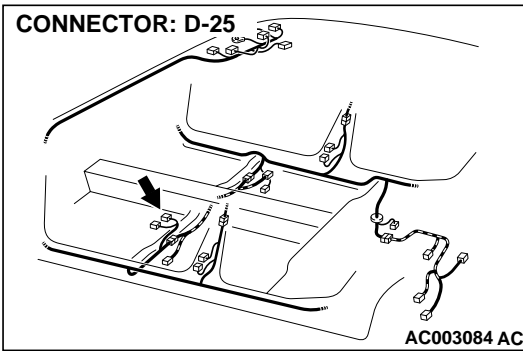

**STEP 4. Check the harness wire between driver's seat belt switch connector D-25 and ground.**

**Q: Is the harness wire between driver's seat belt switch connector D-25 and ground in good condition?**

**YES :** There is no action to be taken.

**NO :** Repair it. The driver's seat belt switch input signal should be able to be checked and the functions, which are described in the "Technical Description (comment)," should work normally.

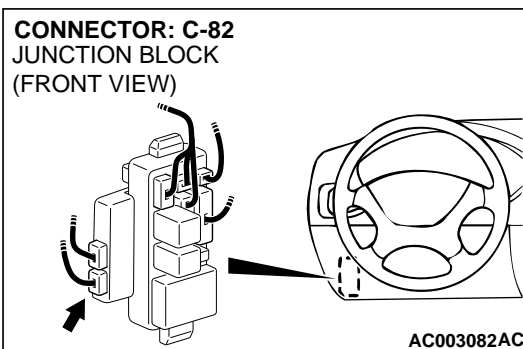

**STEP 5. Check driver's seat belt switch connector D-25 and ETACS-ECU connector C-82 for damage.**

**Q: Are driver's seat belt switch connector D-25 and ETACS-ECU connector C-82 in good condition?**

**YES :** Go to Step 6.

**NO :** Repair or replace them. Refer to GROUP 00E, Harness Connector Inspection [P.00E-2](#) . The driver's seat belt switch input signal should be able to be checked and the functions, which are described in the "Technical Description (comment)," should work normally.

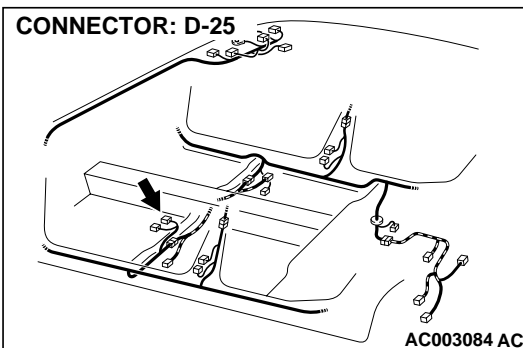

**CONNECTOR: C-82**  
JUNCTION BLOCK  
(FRONT VIEW)

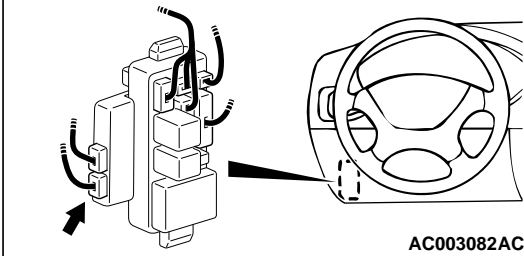

AC003082AC

**CONNECTOR: D-25**

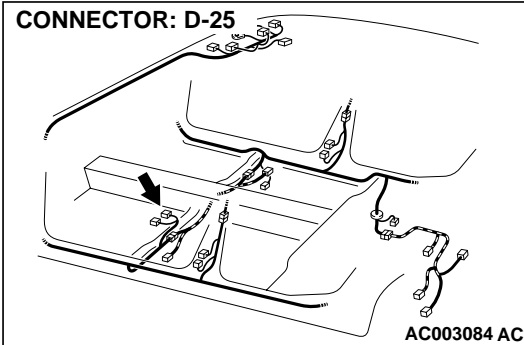

AC003084 AC

**CONNECTOR: C-67**

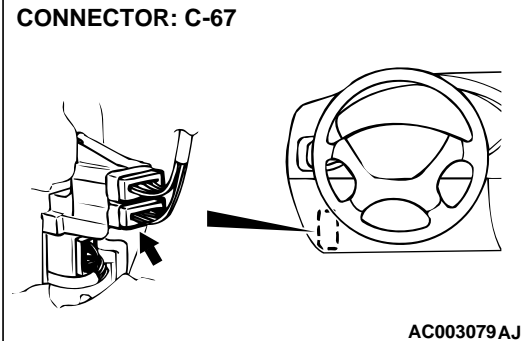

AC003079AJ

**STEP 6. Check the harness wires between driver's seat belt switch connector D-25 and ETACS-ECU connector C-82.**

*NOTE: After checking intermediate connector C-67, check the wires. If intermediate connector C-67 is damaged, repair or replace it. Refer to GROUP 00E, Harness Connector Inspection P.00E-2 .*

**Q: Are the harness wires between driver's seat belt switch connector D-25 and ETACS-ECU connector C-82 in good condition?**

**YES :** Replace the ETACS-ECU. The driver's seat belt switch input signal should be able to be checked and the functions, which are described in the "Technical Description (comment)," should work normally.

**NO :** Repair them. The driver's seat belt switch input signal should be able to be checked and the functions, which are described in the "Technical Description (comment)," should work normally.



**Inspection Procedure N-7: The driver's or front passenger's door switch or door switches signal is not sent to the ETACS-ECU.**

**Driver's Front Passenger's or Rear Door Switch Input Circuit <1999 Models>**

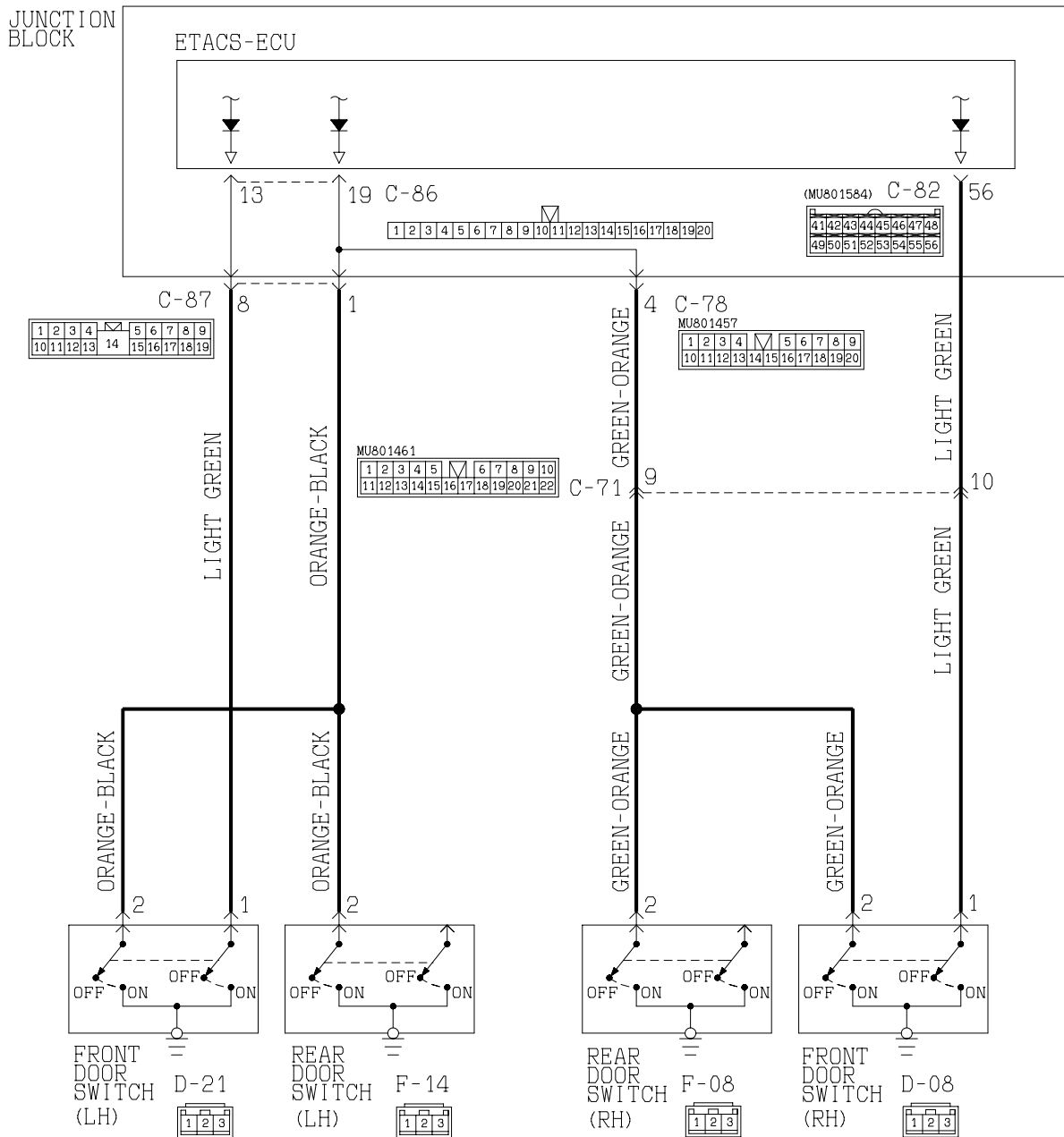

W1809M27AA

AC004239

**TSB Revision**

Driver's Front Passenger's or Rear Door switch Input Circuit <2000 Models>

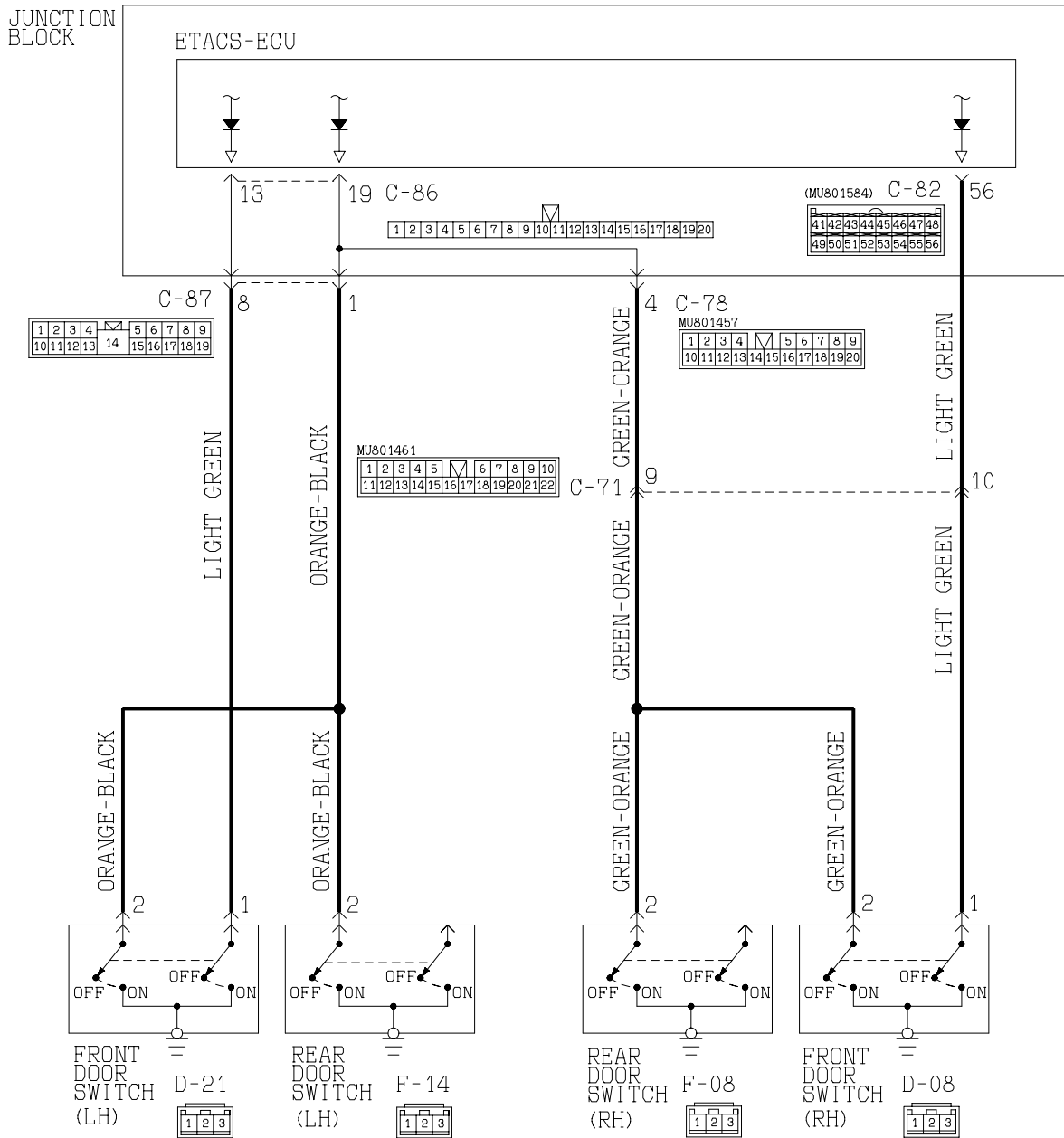

W1609M27AA  
AC004240

TSB Revision

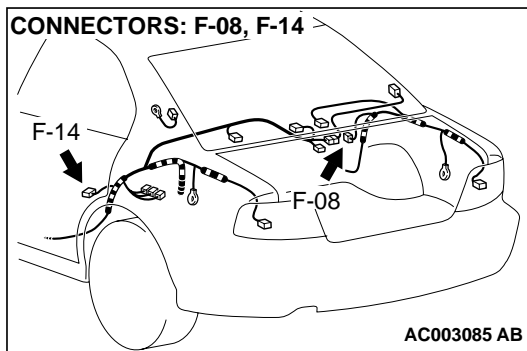
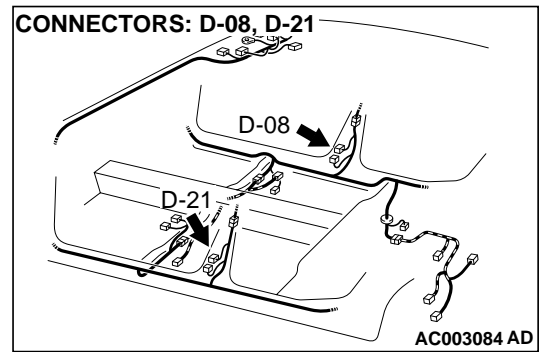
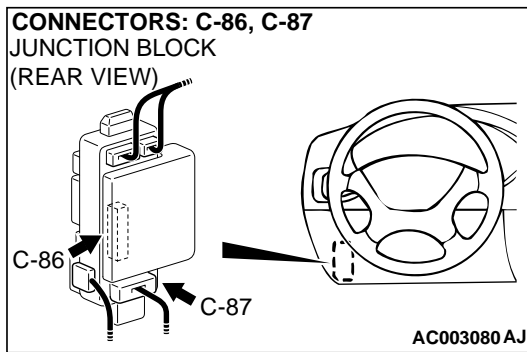
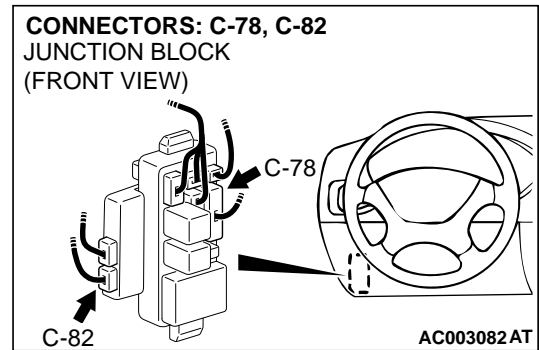
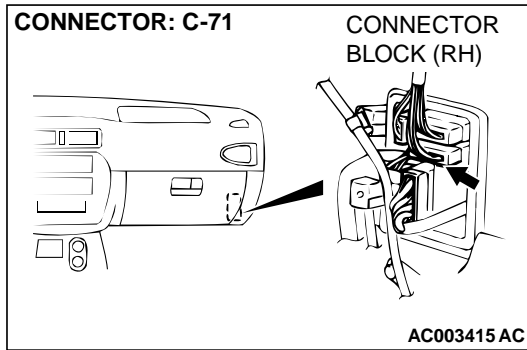

**CIRCUIT OPERATION**

The ETACS-ECU operates various functions according to the input signal from the driver's or front passenger's door switch.

**TECHNICAL DESCRIPTION (COMMENT)**

The driver's and front passenger's door switch and door switches are used to operate the following devices or systems:

- Ignition key reminder tone alarm function (driver's door switch only)
- Light reminder tone alarm function (driver's door switch only)
- Forgotten key prevention function (driver's and front passenger's door switch only)

- Power window timer function (driver's and front passenger's door switch only)
- Keyless entry system <vehicles with keyless entry system> (door switch)
- Dome light (door switch)
- Theft-alarm system <vehicles with theft-alarm system> (door switch)

If the signal fails, these devices will not work normally.

**TROUBLESHOOTING HINTS**

- Malfunction of the driver's, front passenger's or rear door switch
- Malfunction of the ETACS-ECU
- Damaged harness wires or connectors

**DIAGNOSIS**

**Required Special Tools:**

- MB991223: Test Harness Set
- MB991502: Scan Tool (MUT-II)

**TSB Revision**

- MB991529: Diagnostic Trouble Code Check Harness

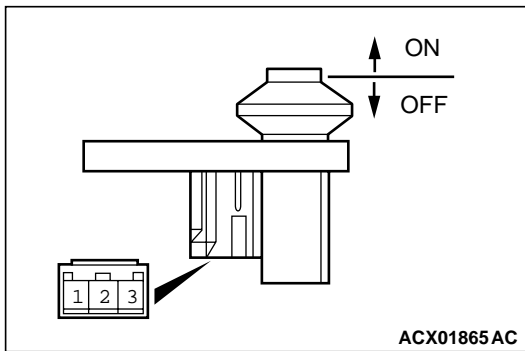
**STEP 1. Check the door switch.**

SWITCH POSITION	TESTER CONNECTION	SPECIFIED CONDITION
Released	1 – 2	Continuity
Pressed	–	No continuity

**Q: Is the door switch in good condition?****YES** : Go to Step 2.**NO** : Replace it. The driver's and front passenger's door switch and door switches input signal should be able to be checked and the functions, which are described in the "Technical Description (comment)," should work normally.**STEP 2. Check the door switch installation state.***NOTE: The door switch is grounded to the body through the mounting screws.*

Remove the cap and measure the resistance between the lower metal part and the ground.

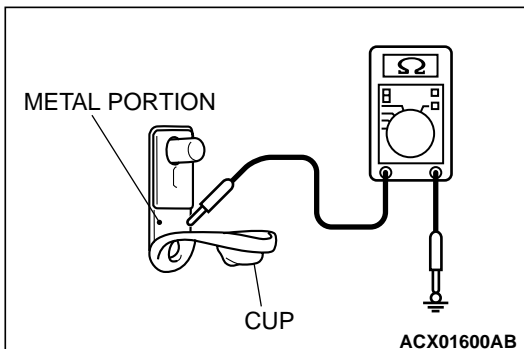
**Q: Is the resistance less than 2 ohm?****YES** : Go to Step 3.**NO** : Check the installation state and repair. The driver's and front passenger's door switch and door switches input signal should be able to be checked and the functions, which are described in the "Technical Description (comment)," should work normally.**STEP 3. Check the location of malfunction.****Q: Which door switch signal is not input?****Driver's door** : Go to Step 4.**Front passenger's door** : Go to Step 6.**Rear door (LH)** : Go to Step 8.**Rear door (RH)** : Go to Step 10.

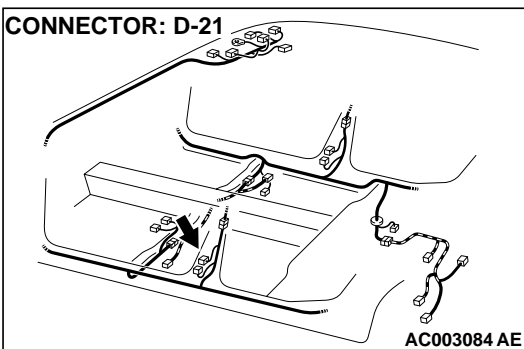
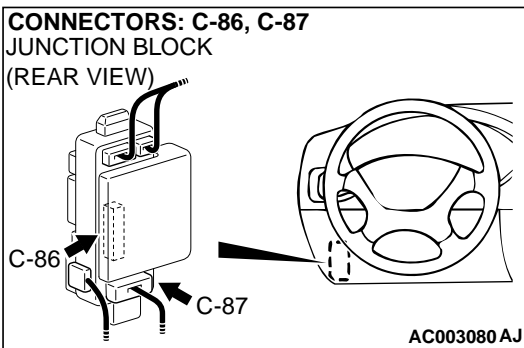
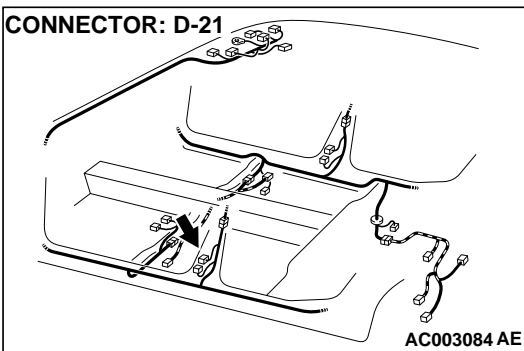
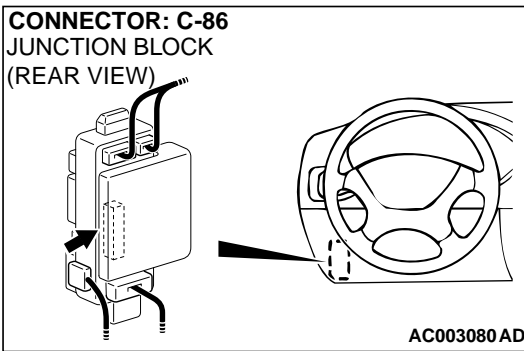

**STEP 4. Check driver's door switch connector D-21 and ETACS-ECU connector C-86 for damage.**

**Q: Are driver's door switch connector D-21 and ETACS-ECU connector C-86 in good condition?**

**YES :** Go to Step 5.

**NO :** Repair or replace them. Refer to GROUP 00E, Harness Connector Inspection [P.00E-2](#). The driver's door switch input signal should be able to be checked and the functions, which are described in the "Technical Description (comment)," should work normally.

**STEP 5. Check the harness wires between driver's door switch connector D-21 and ETACS-ECU connector C-86.**

*NOTE: After checking junction block connector C-87, check the wires. If junction block connector C-87 is damaged, repair or replace it. Refer to GROUP 00E, Harness Connector Inspection [P.00E-2](#).*

**Q: Is the harness wires between the driver's door switch connector D-21 and ETACS-ECU connector C-86 in good condition?**

**YES :** Replace the ETACS-ECU. The driver's door switch input signal should be able to be checked and the functions, which are described in the "Technical Description (comment)," should work normally.

**NO :** Repair them. The driver's door switch input signal should be able to be checked and the functions, which are described in the "Technical Description (comment)," should work normally.

**CONNECTOR: C-82**  
JUNCTION BLOCK  
(FRONT VIEW)

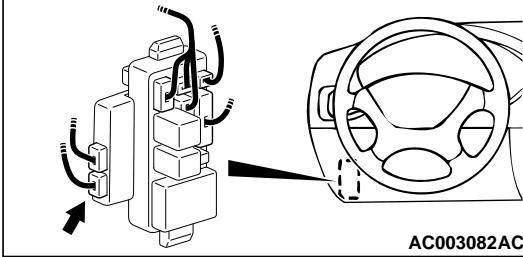

**CONNECTOR: C-86**  
JUNCTION BLOCK  
(REAR VIEW)

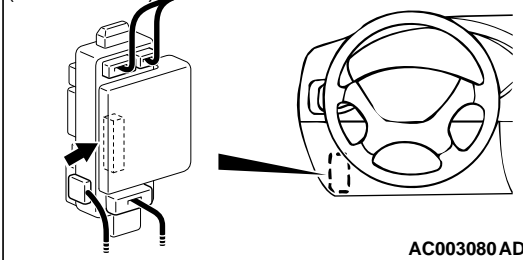

**CONNECTOR: D-08**

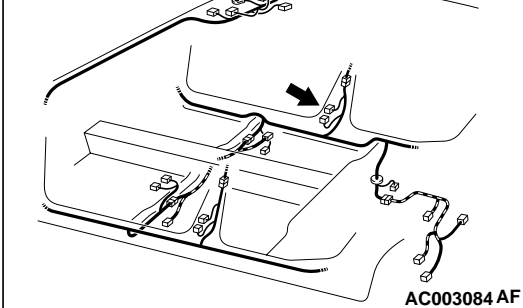

**STEP 6.** Check front passenger's door switch connector D-08 and ETACS-ECU connectors C-82 and C-86 for damage.  
**Q:** Are front passenger's door switch connector D-21 and ETACS-ECU connectors C-82 and C-86 in good condition?

**YES :** Go to Step 7.

**NO :** Repair or replace them. Refer to GROUP 00E, Harness Connector Inspection [P.00E-2](#). The front passenger's door switch input signal should be able to be checked and the functions, which are described in the "Technical Description (comment)," should work normally.

**STEP 7.** Check the harness wires between front passenger's door switch connector D-08 and ETACS-ECU connectors C-82 and C-86.

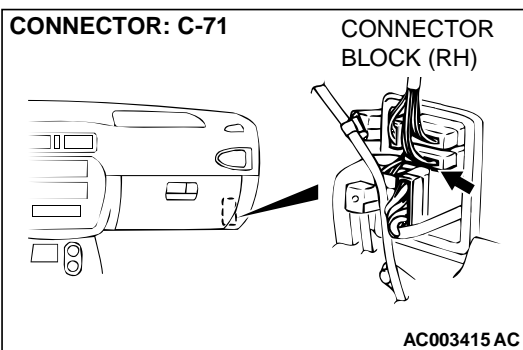
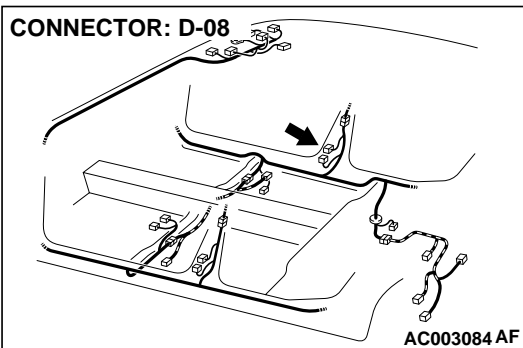
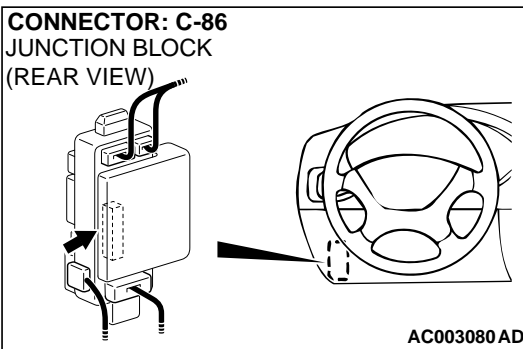
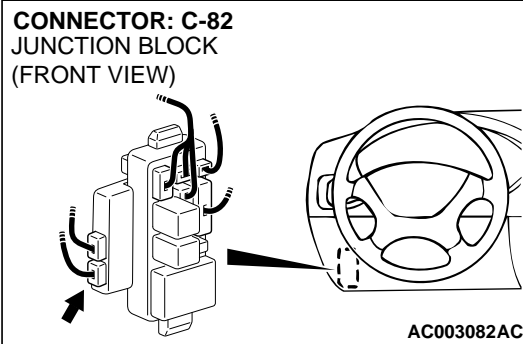

**CONNECTOR: C-78**  
JUNCTION BLOCK  
(FRONT VIEW)

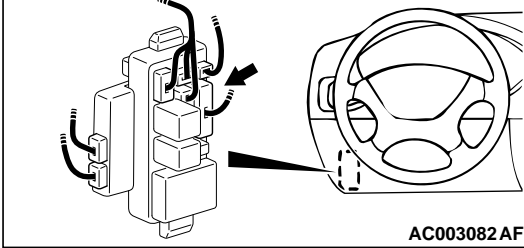

*NOTE: After checking intermediate connector C-71 and junction block connector C-87, check the wires. If intermediate connector C-71 and junction block connector C-87 are damaged, repair or replace them. Refer to GROUP 00E, Harness Connector Inspection P.00E-2.*

**Q: Are the harness wires between front passenger's door switch connector D-08 and ETACS-ECU connector C-82 and C-86 in good condition?**

**YES :** Replace the ETACS-ECU. The passenger's door switch input signal should be able to be checked and the functions, which are described in the "Technical Description (comment)," should work normally.

**NO :** Repair them. The front passenger's door switch input signal should be able to be checked and the functions, which are described in the "Technical Description (comment)," should work normally.

**CONNECTOR: C-86**  
JUNCTION BLOCK  
(REAR VIEW)

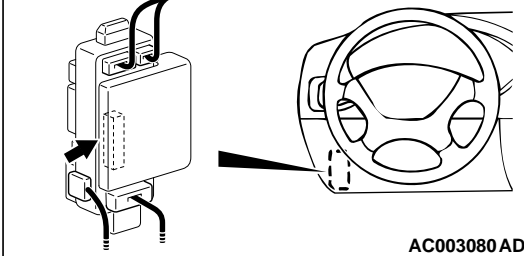

**STEP 8. Check rear door switch (LH) connector F-14 and ETACS-ECU connector C-86 for damage.**

**Q: Are driver's door switch connector F-14 and ETACS-ECU connector C-86 in good condition?**

**YES :** Go to Step 9.

**NO :** Repair or replace them. Refer to GROUP 00E, Harness Connector Inspection P.00E-2. The rear door (LH) switch input signal should be able to be checked and the functions, which are described in the "Technical Description (comment)," should work normally.

**CONNECTOR: F-14**

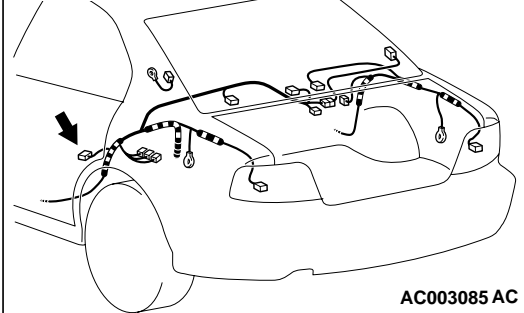



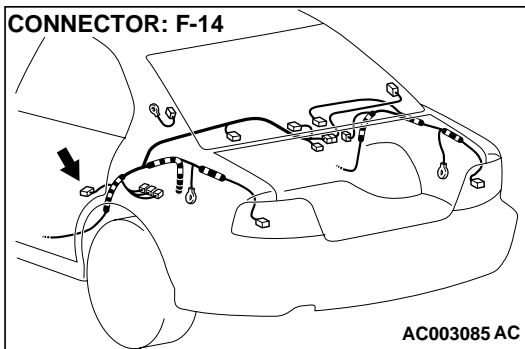
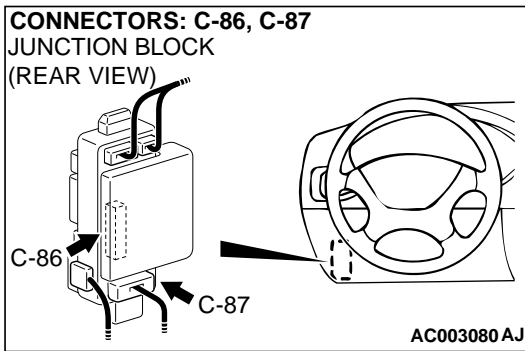

**STEP 9. Check the harness wires between rear door switch (LH) connector F-14 and ETACS-ECU connector C-86.**

**NOTE:** After checking junction block connector C-87, check the wires. If junction block connector C-87 are damaged, repair or replace it. Refer to GROUP 00E, Harness Connector Inspection [P.00E-2](#).

**Q: Is the harness wires between the rear door switch (LH) connector F-14 and ETACS-ECU connector C-86 in good condition?**

**YES :** Replace the ETACS-ECU. The driver's door switch input signal should be able to be checked and the functions, which are described in the "Technical Description (comment)," should work normally.

**NO :** Repair them. The rear door switch (LH) input signal should be able to be checked and the functions, which are described in the "Technical Description (comment)," should work normally.

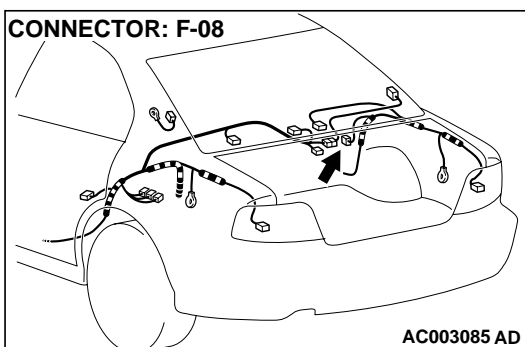
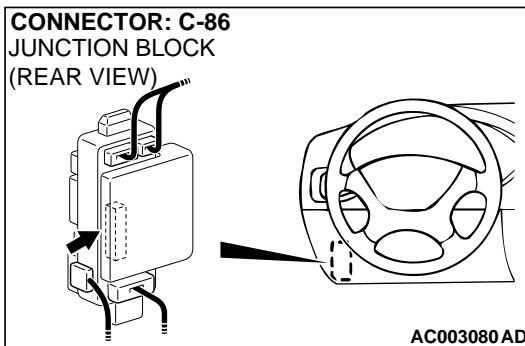

**STEP 10. Check rear door switch (RH) connector F-08 and ETACS-ECU connectors C-86 for damage.**

**Q: Are rear door switch (RH) connector F-08 and ETACS-ECU connectors C-86 in good condition?**

**YES :** Go to Step 11.

**NO :** Repair or replace them. Refer to GROUP 00E, Harness Connector Inspection [P.00E-2](#). The rear door switch (RH) input signal should be able to be checked and the functions, which are described in the "Technical Description (comment)," should work normally.

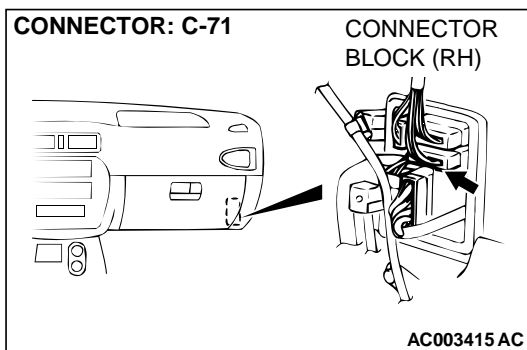
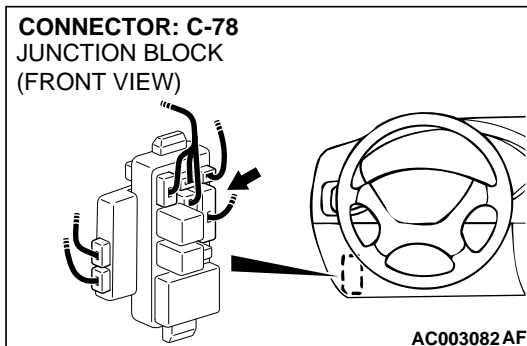
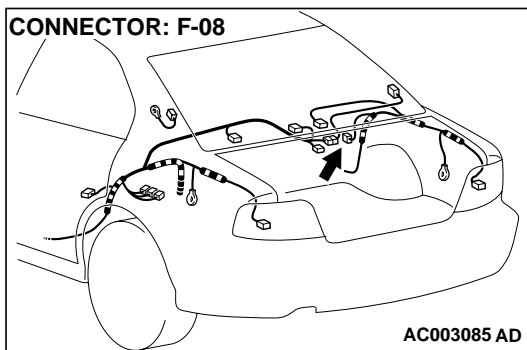
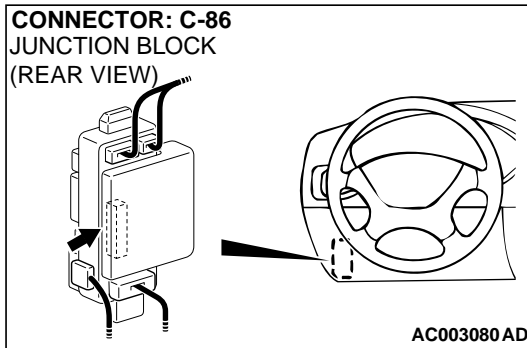

**STEP 11. Check the harness wires between rear door switch (RH) connector F-08 and ETACS-ECU connectors C-86.**

*NOTE: After checking intermediate connector C-71 and junction block connector C-78, check the wires. If intermediate connector C-71 and junction block connector C-78 are damaged, repair or replace them. Refer to GROUP 00E, Harness Connector Inspection P.00E-2.*

**Q: Are the harness wires between rear door switch (RH) connector F-08 and ETACS-ECU connector C-86 in good condition?**

**YES :** Replace the ETACS-ECU. The passenger's door switch input signal should be able to be checked and the functions, which are described in the "Technical Description (comment)," should work normally.

**NO :** Repair them. The rear door switch (RH) input signal should be able to be checked and the functions, which are described in the "Technical Description (comment)," should work normally.

**Inspection Procedure N-8: The driver's or front passenger's door lock key cylinder switch is not sent to the ETACS-ECU.**

**Driver's or Front Passenger's Door Lock Key Cylinder Switch Input Circuit**

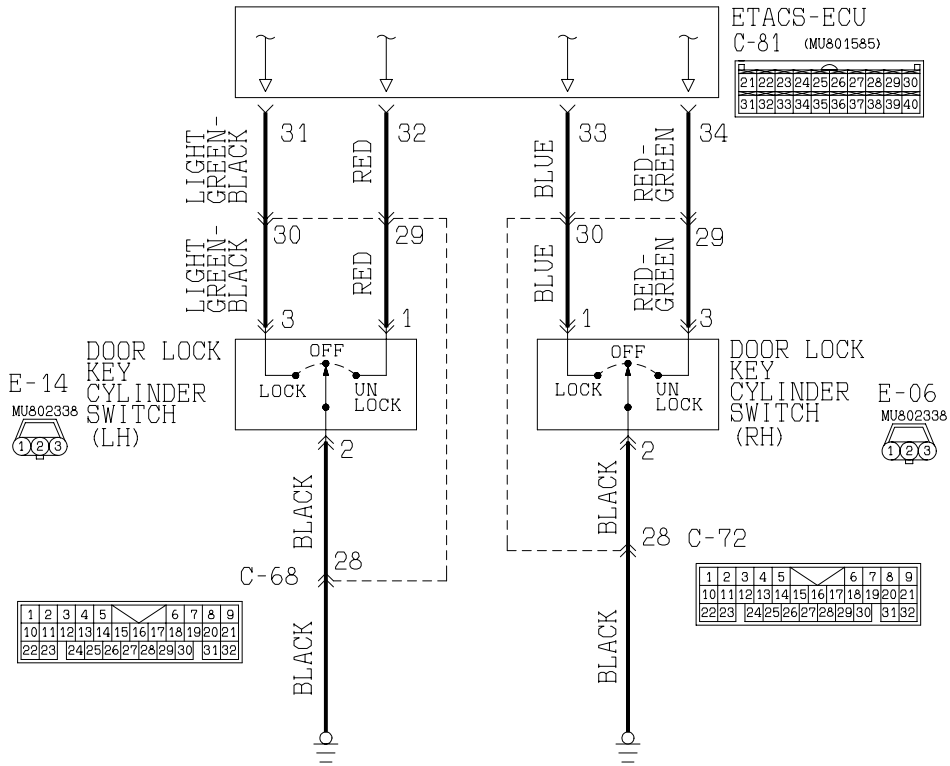

W 1S09M28AA

**AC004241**

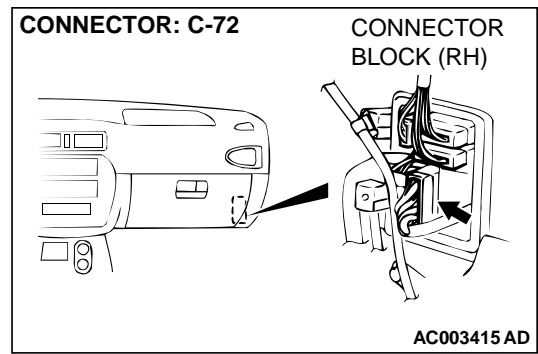
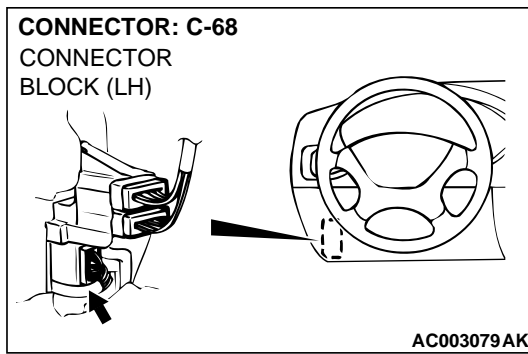

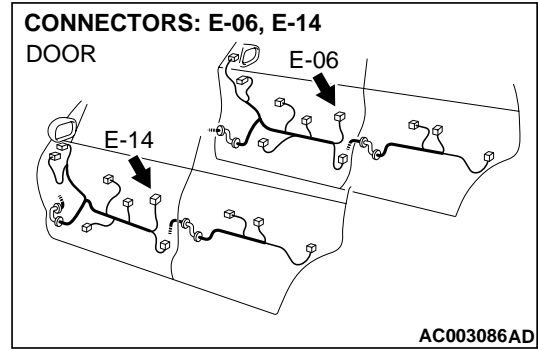
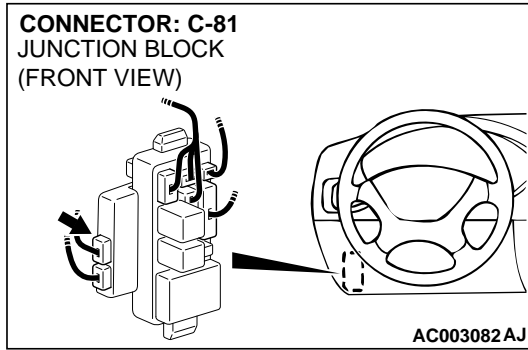

**CIRCUIT OPERATION**

The ETACS-ECU uses the input signals from the driver's and front passenger's door lock key cylinder switch to operate the following devices or functions.

**TECHNICAL DESCRIPTION (COMMENT)**

The driver's and front passenger's door lock key cylinder switch input signals is used to operate the following devices or functions:

- Central door locking system

- Theft-alarm system <vehicles with theft-alarm system>

If the signal fails, these devices will not work normally.

**TROUBLESHOOTING HINTS**

- Malfunction of the driver's or front passenger's door lock key cylinder switch
- Malfunction of the ETACS-ECU
- Damaged harness wires or connectors

**DIAGNOSIS**

**Required Special Tools:**

- MB991223: Test Harness Set
- MB991502: Scan Tool (MUT-II)
- MB991529: Diagnostic Trouble Code Check Harness

**STEP 1. Check the location of malfunction.**

**Q: Which door key switch signal is not input?**

**Driver's door :** Go to Step 2.

**Front passenger's door :** Go to Step 8.

**STEP 2. Check the driver's door lock key cylinder switch.**

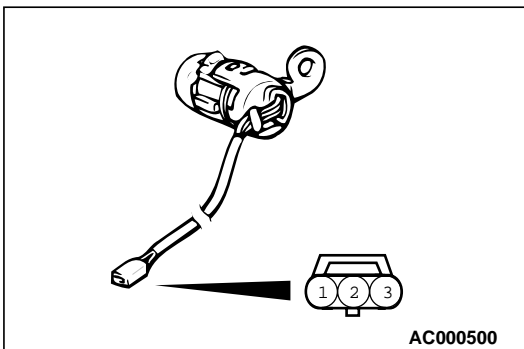

SWITCH POSITION	TESTER CONNECTION	SPECIFIED CONDITION
LOCK	2 – 3	Continuity
Neutral (OFF)	–	No continuity
UNLOCK	1 – 2	Continuity

**Q: Is the driver's door lock key cylinder switch in good condition?**

**YES :** Go to Step 3.

**NO :** Replace it. The input signal from the driver's door lock key cylinder switch should be able to be checked and the functions, which are described in the "Technical Description (comment)," should work normally.

**STEP 3. Check the driver's door lock key cylinder switch ground circuit at driver's door lock key cylinder switch connector E-14.**

- (1) Disconnect driver's door lock key cylinder switch connector E-14 and measure at the harness side.
- (2) Measure the resistance between terminal 2 and ground.

**Q: Is the resistance less than 2 ohm?**

**YES :** Go to Step 6.

**NO :** Go to Step 4.

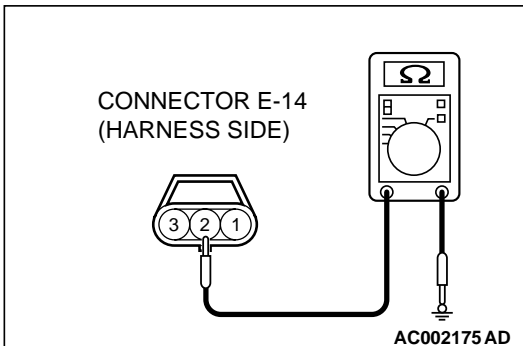

**STEP 4. Check driver's door lock key cylinder switch connector E-14 for damage.**

**Q: Is driver's door lock key cylinder switch connector E-14 in good condition?**

**YES :** Go to Step 5.

**NO :** Repair or replace it. Refer to GROUP 00E, Harness Connector Inspection [P.00E-2](#) . The input signal from the driver's door lock key cylinder switch should be able to be checked and the functions, which are described in the "Technical Description (comment)," should work normally.

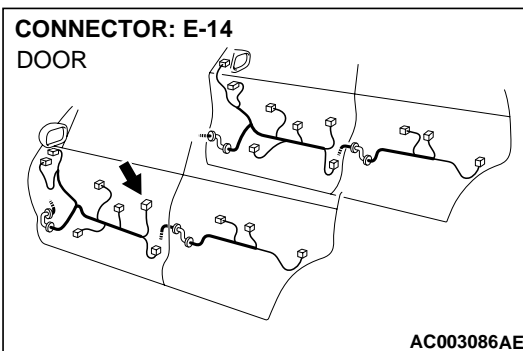

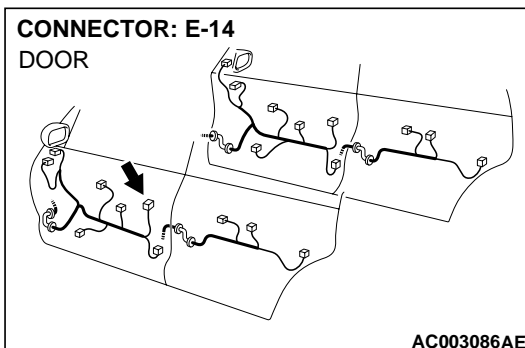
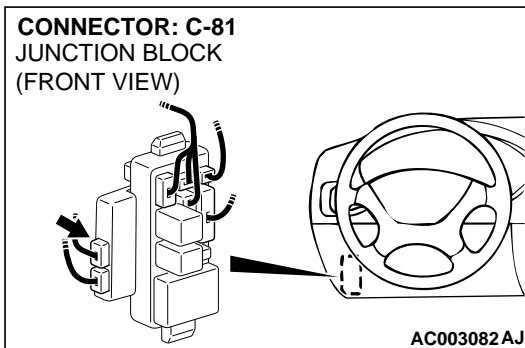
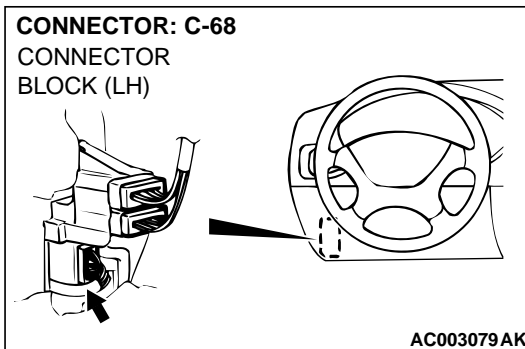
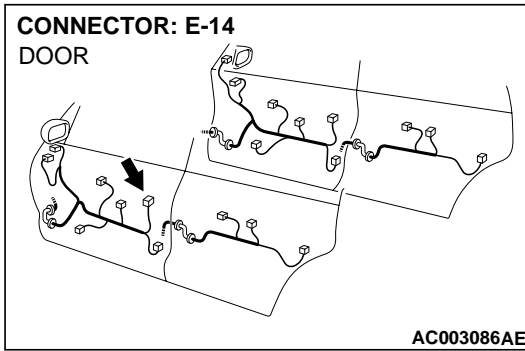

**STEP 5. Check the harness wires between driver's door lock key cylinder switch connector E-14 and ground.**

**NOTE:** After checking intermediate connector C-68, check the wires. If intermediate connector C-68 is damaged, repair or replace it. Refer to GROUP 00E, Harness Connector Inspection P.00E-2.

**Q: Are the harness wires between driver's door lock key cylinder switch connector E-14 and ground in good condition?**

**YES :** There is no action to be taken.

**NO :** Repair them. The input signal from the driver's door lock key cylinder switch should be able to be checked and the functions, which are described in the "Technical Description (comment)," should work normally.

**STEP 6. Check the driver's door lock key cylinder switch connector E-14 and ETACS-ECU connector C-81 for damage.**

**Q: Are driver's door lock key cylinder switch connector E-14 and ETACS-ECU connector C-81 in good condition?**

**YES :** Go to Step 7.

**NO :** Repair or replace them. Refer to GROUP 00E, Harness Connector Inspection P.00E-2. The input signal from the driver's door lock key cylinder switch should be able to be checked and the functions, which are described in the "Technical Description (comment)," should work normally.

**CONNECTOR: C-81**  
JUNCTION BLOCK  
(FRONT VIEW)

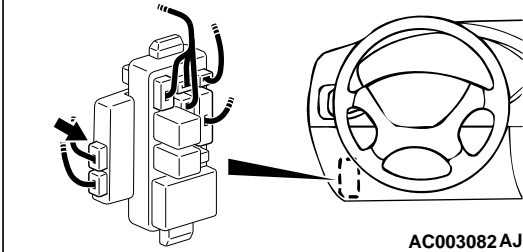

AC003082AJ

**CONNECTOR: E-14**  
DOOR

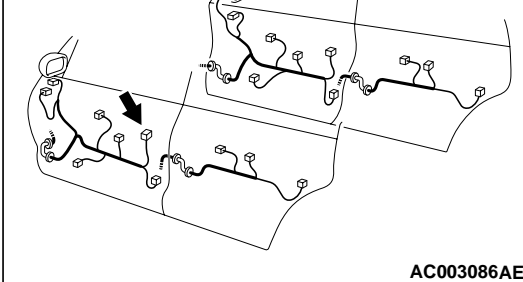

AC003086AE

**CONNECTOR: C-68**  
CONNECTOR  
BLOCK (LH)

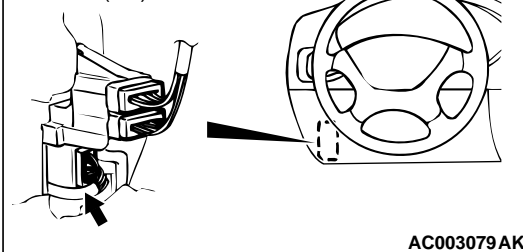

AC003079AK

**STEP 7. Check the harness wires between driver's door lock key cylinder switch connector E-14 and ETACS-ECU connector C-81.**

*NOTE: After checking intermediate connector C-68, check the wires. If intermediate connector C-68 is damaged, repair or replace it. Refer to GROUP 00E, Harness Connector Inspection P.00E-2 .*

**Q: Are the harness wires between driver's door lock key cylinder switch connector E-14 and ETACS-ECU connector C-81 in good condition?**

**YES :** Replace the ETACS-ECU. The input signal from the driver's door lock key cylinder switch should be able to be checked and the functions, which are described in the "Technical Description (comment)," should work normally.

**NO :** Repair them. The input signal from the driver's door lock key cylinder switch should be able to be checked and the functions, which are described in the "Technical Description (comment)," should work normally.

**STEP 8. Check the front passenger's door lock key cylinder switch.**

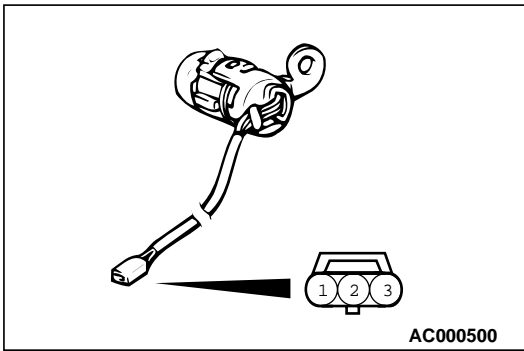

SWITCH POSITION	TESTER CONNECTION	SPECIFIED CONDITION
LOCK	1 – 2	Continuity
Neutral (OFF)	–	No continuity
UNLOCK	2 – 3	Continuity

**Q: Is the front passenger's door lock key cylinder switch in good condition?**

**YES :** Go to Step 9.

**NO :** Replace it. The input signal from the front passenger's door lock key cylinder switch should be able to be checked and the functions, which are described in the "Technical Description (comment)," should work normally.

**STEP 9. Check the front passenger's door lock key cylinder switch ground circuit at driver's door lock key cylinder switch connector E-06.**

- (1) Disconnect front passenger's door lock key cylinder switch connector E-06 and measure at the harness side.
- (2) Measure the resistance between terminal 2 and ground.

**Q: Is the resistance less than 2 ohm?**

**YES :** Go to Step 12.

**NO :** Go to Step 10.

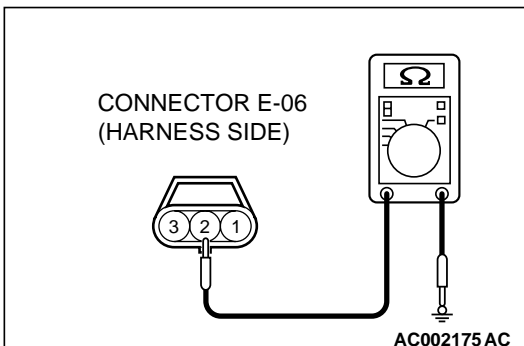

**STEP 10. Check front passenger's door lock key cylinder switch connector E-06 for damage.**

**Q: Is front passenger's door lock key cylinder switch connector E-06 in good condition?**

**YES :** Go to Step 11.

**NO :** Repair or replace it. Refer to GROUP 00E, Harness Connector Inspection [P.00E-2](#) . The input signal from the front passenger's door lock key cylinder switch should be able to be checked and the functions, which are described in the "Technical Description (comment)," should work normally.

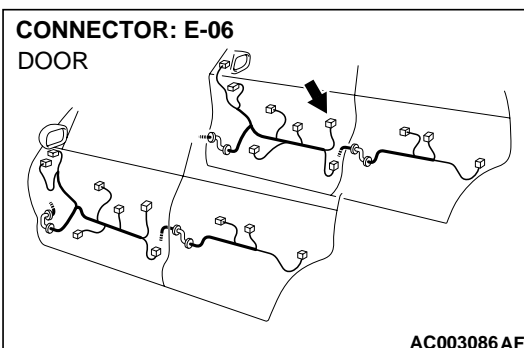



**STEP 11. Check the harness wires between front passenger's door lock key cylinder switch connector E-06 and ground.**

*NOTE: After checking intermediate connector C-72, check the wires. If intermediate connector C-72 is damaged, repair or replace it. Refer to GROUP 00E, Harness Connector Inspection P.00E-2 .*

**Q: Are the harness wires between front passenger's door lock key cylinder switch connector E-06 and ground in good condition?**

**YES :** There is no action to be taken.

**NO :** Repair them. The input signal from the front passenger's door lock key cylinder switch should be able to be checked and the functions, which are described in the "Technical Description (comment)," should work normally.

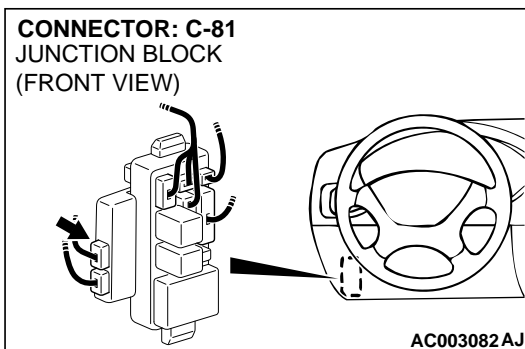
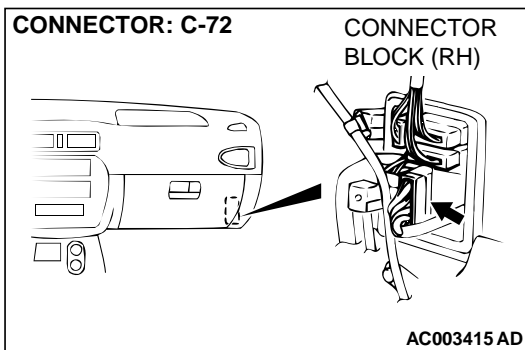
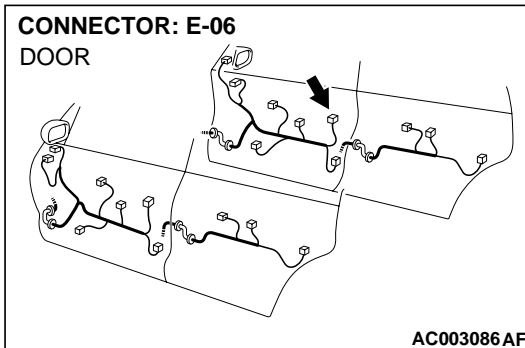

**STEP 12. Check the front passenger's door lock key cylinder switch connector E-06 and ETACS-ECU connector C-81 for damage.**

**Q: Are front passenger's door lock key cylinder switch connector E-06 and ETACS-ECU connector C-81 in good condition?**

**YES :** Go to Step 13.

**NO :** Repair or replace them. Refer to GROUP 00E, Harness Connector Inspection P.00E-2 . The input signal from the front passenger's door lock key cylinder switch should be able to be checked and the functions, which are described in the "Technical Description (comment)," should work normally.

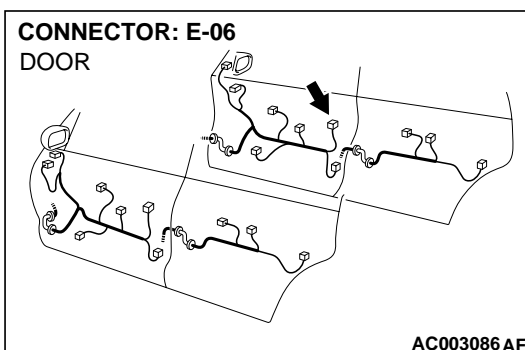

**CONNECTOR: C-81**  
JUNCTION BLOCK  
(FRONT VIEW)

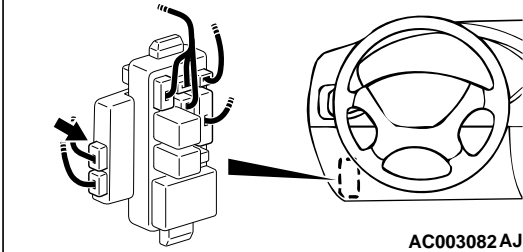

**CONNECTOR: E-06**  
DOOR

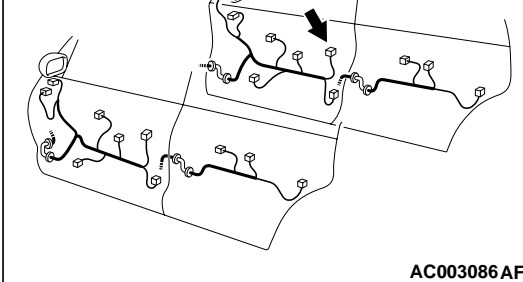

**CONNECTOR: C-72**

CONNECTOR  
BLOCK (RH)

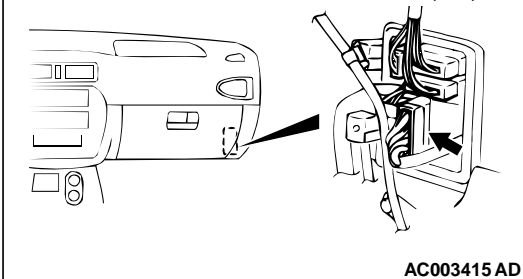

**STEP 13. Check the harness wires between front passenger's door lock key cylinder switch connector E-06 and ETACS-ECU connector C-81.**

*NOTE: After checking intermediate connector C-72, check the wires. If intermediate connector C-72 is damaged, repair or replace it. Refer to GROUP 00E, Harness Connector Inspection P.00E-2 .*

**Q: Are the harness wires between front passenger's door lock key cylinder switch connector E-06 and ETACS-ECU connector C-81 in good condition?**

**YES :** Replace the ETACS-ECU. The input signal from the front passenger's door lock key cylinder switch should be able to be checked and the functions, which are described in the "Technical Description (comment)," should work normally.

**NO :** Repair them. The input signal from the front passenger's door lock key cylinder switch should be able to be checked and the functions, which are described in the "Technical Description (comment)," should work normally.

**Inspection Procedure N-9: The driver's or front passenger's door lock actuator switch is not sent to the ETACS-ECU.**

**Driver's or Front Passenger's Door Lock Actuator Switch Input Circuit**

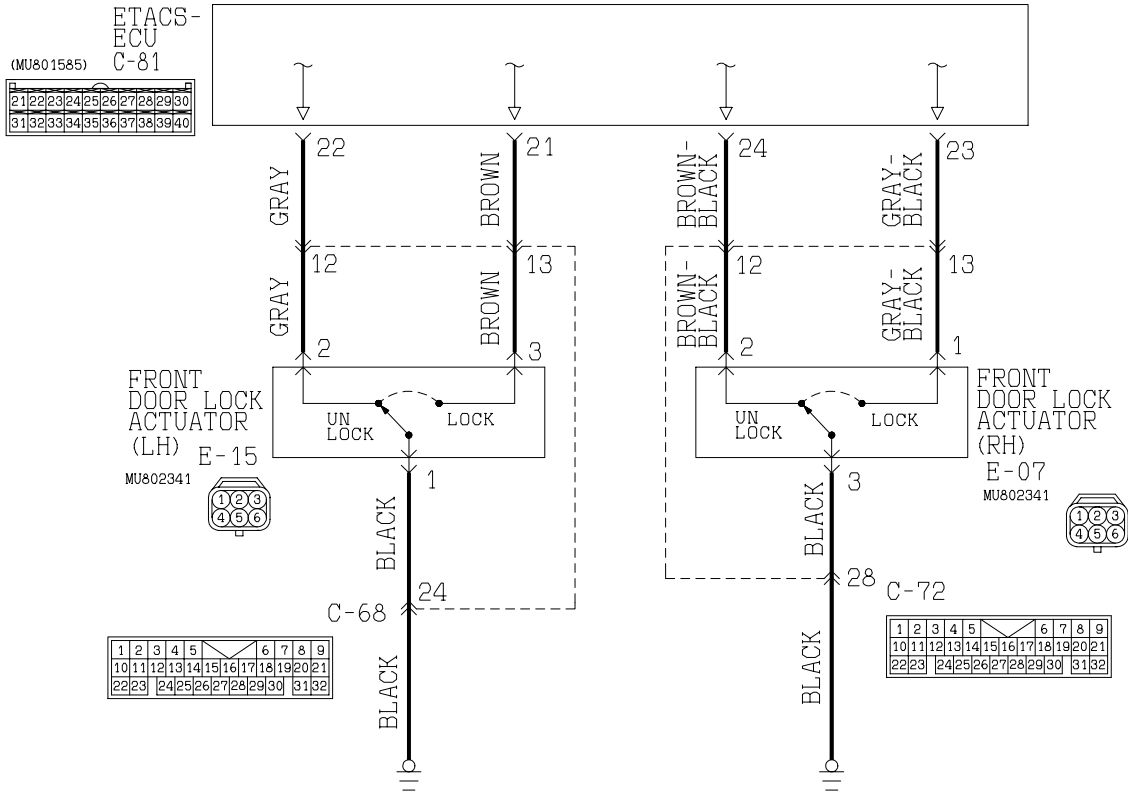

W1S09M29AA  
AC004242

Rear Door Lock Actuator Switch Input Circuit <Vehicles with Theft-alarm System Only>

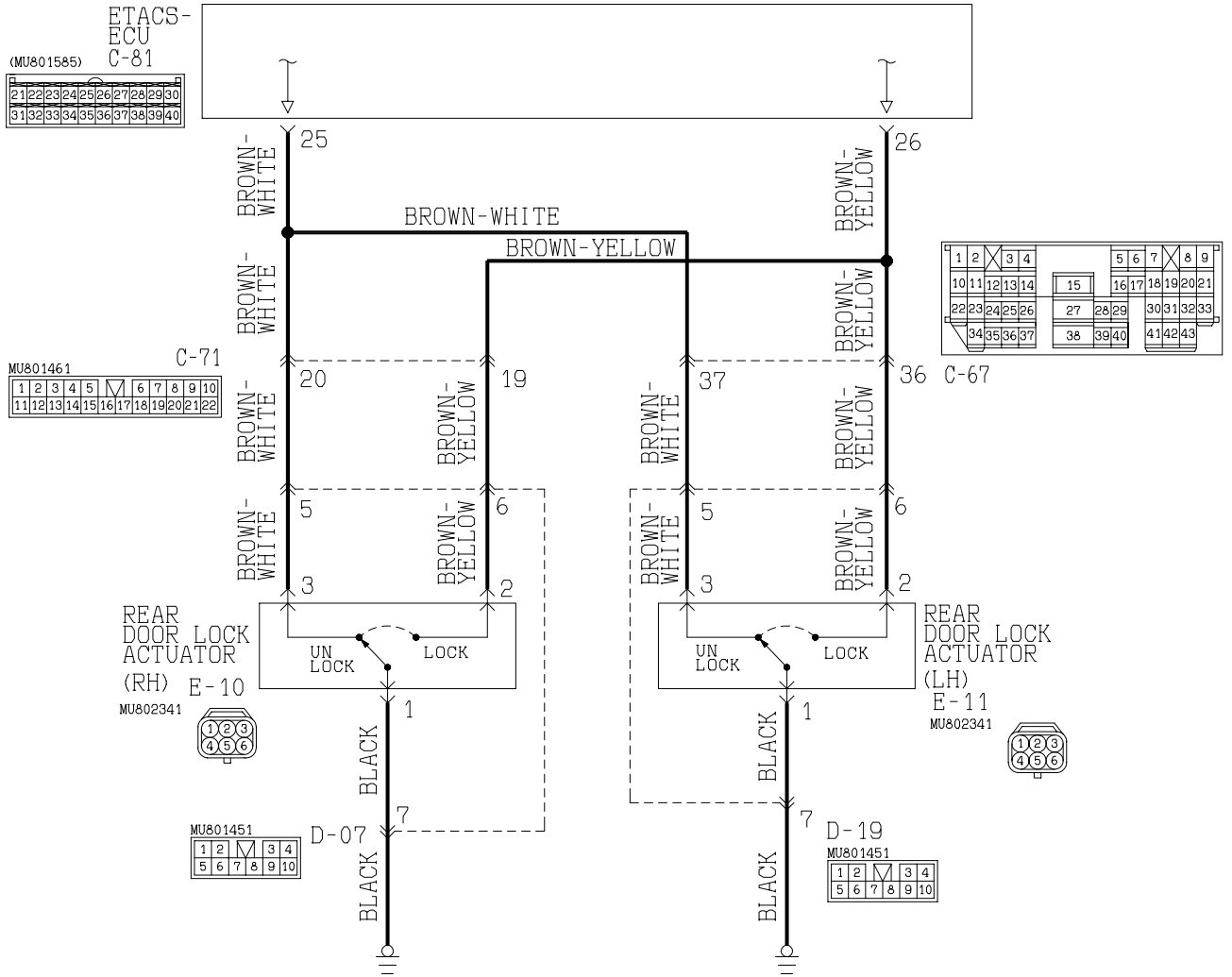

W1509M30AA

AC004243

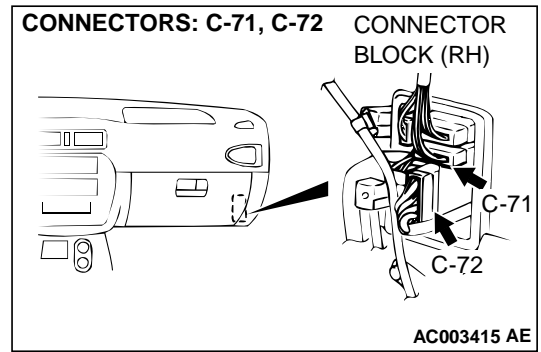
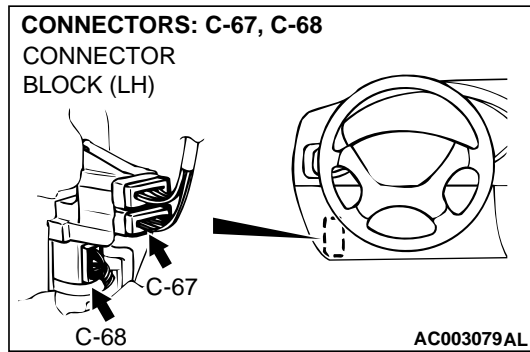

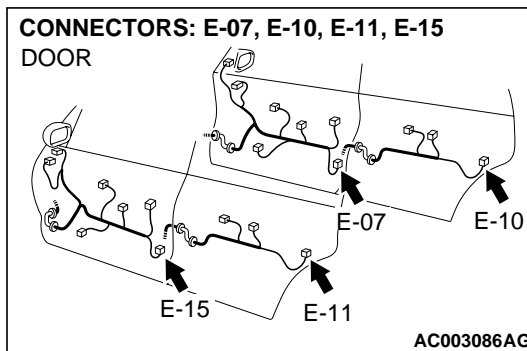
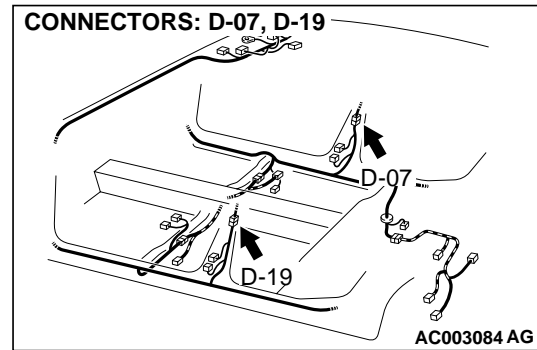
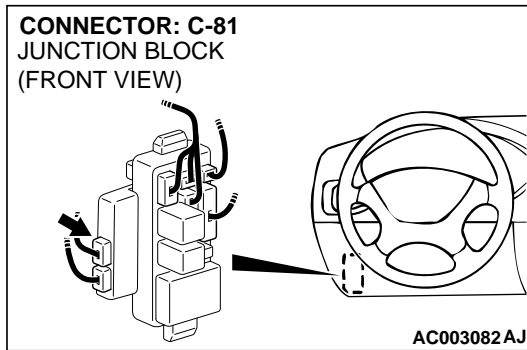

**CIRCUIT OPERATION**

The ETACS-ECU uses the input signal from the driver's, front passenger's, rear and back door lock actuator switch to operate the following functions.

**TECHNICAL DESCRIPTION (COMMENT)**

**<Driver's door lock actuator switch>**

The input signal from the driver's door lock actuator switch is used to operate the following systems or functions:

- Central door locking system
- Forgotten key prevention function
- Keyless entry system <vehicles with keyless entry system>
- Dome light dimming function
- Theft-alarm system <vehicles with theft-alarm system>

If the signal fails, these systems or function will not work normally.

**TECHNICAL DESCRIPTION (COMMENT) <Front passenger's door lock actuator switch>**

The input signal from the front passenger's door lock actuator switch is used to operate the following systems or functions:

- Forgotten key prevention function
- Theft-alarm system <vehicles with theft-alarm system>

If the signal fails, these systems or function will not work normally.

**TECHNICAL DESCRIPTION (COMMENT) <Rear door lock actuator switch>**

The input signal from the rear door lock actuator switch is used to operate the Theft-alarm system <vehicles with theft-alarm system> or function. If the signal fails, these systems or function will not work normally.

**TROUBLESHOOTING HINTS**

- Malfunction of the driver's or front passenger's door latch assembly
- Malfunction of the rear door latch assembly
- Malfunction of the ETACS-ECU
- Damaged harness wires or connectors

**DIAGNOSIS**

**Required Special Tools:**

- MB991223: Test Harness Set
- MB991502: Scan Tool (MUT-II)
- MB991529: Diagnostic Trouble Code Check Harness

**STEP 1. Check the location of malfunction.**

**Q: Which door lock actuator switch signal is not input?**

**Driver's door :** Go to Step 2.

**Front passenger's door :** Go to Step 8.

**Rear door (LH) :** Go to Step 14.

**Rear door (RH) :** Go to Step 20.

**STEP 2. Check the driver's door lock actuator switch.**

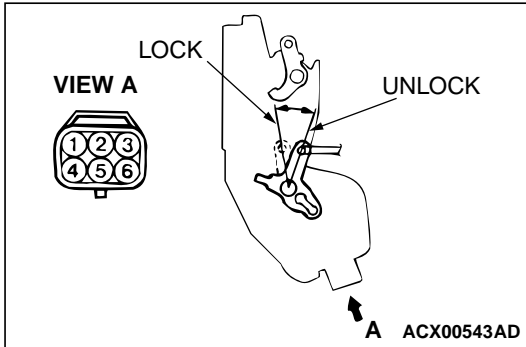

ROD POSITION	TESTER CONNECTION	SPECIFIED CONDITION
LOCK	1 – 3	Continuity
UNLOCK	1 – 2	Continuity

**Q: Is the driver's door lock actuator switch in good condition?**

**YES :** Go to Step 3.

**NO :** Replace it. The input signal from the driver's door lock actuator switch should be able to be checked and the functions, which are described in the "Technical Description (comment)," should work normally.

**STEP 3. Check the driver's door lock actuator switch ground circuit at driver's door lock actuator switch connector E-15**

- (1) Disconnect driver's door lock actuator switch connector E-15 and measure at the harness side.
- (2) Measure the resistance between terminal 1 and ground.

**Q: Is the resistance less than 2 ohm?**

**YES :** Go to Step 6.

**NO :** Go to Step 4.

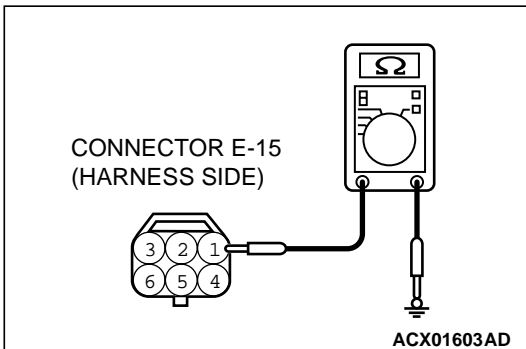

**STEP 4. Check driver's door lock actuator switch connector E-15 for damage.**

**Q: Is driver's door lock actuator switch connector E-15 in good condition?**

**YES :** Go to Step 5.

**NO :** Repair or replace it. Refer to GROUP 00E, Harness Connector Inspection. The input signal from the driver's door lock actuator switch should be able to be checked and the functions, which are described in the "Technical Description (comment)," should work normally.

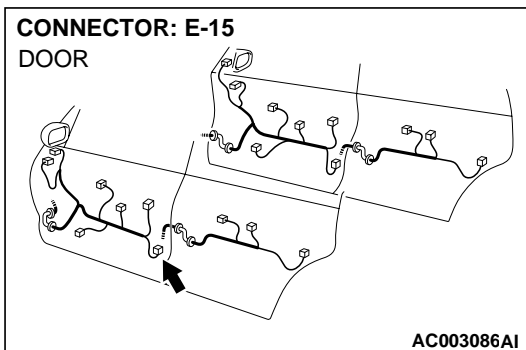

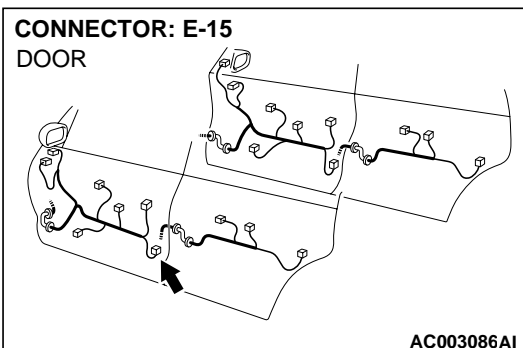
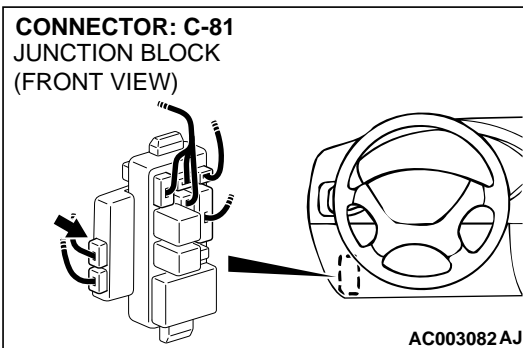
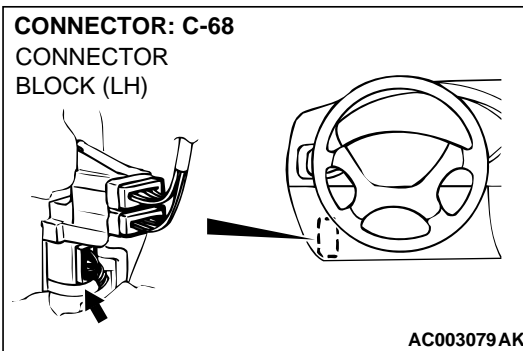
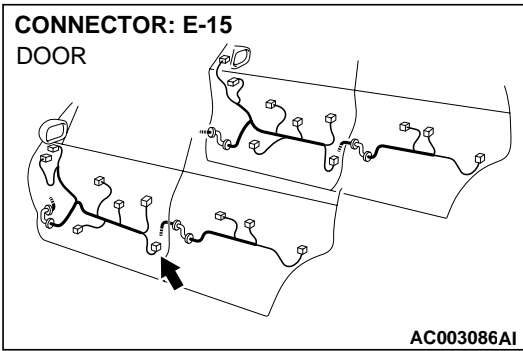

**STEP 5. Check the harness wires between driver's door lock actuator switch connector E-15 and ground.**

**NOTE:** After checking intermediate connector C-68, check the wires. If intermediate connector C-68 is damaged, repair or replace it. Refer to GROUP 00E, Harness Connector Inspection [P.00E-2](#).

**Q: Are the harness wires between driver's door lock actuator switch connector E-15 and ground in good condition?**

**YES :** There is no action to be taken.

**NO :** Repair them. The input signal from the driver's door lock actuator switch should be able to be checked and the functions, which are described in the "Technical Description (comment)," should work normally.

**STEP 6. Check the driver's door lock actuator switch connector E-15 and ETACS-ECU connector C-81 for damage.**

**Q:**

**YES :** Go to Step 7.

**NO :** Repair or replace them. Refer to GROUP 00E, Harness Connector Inspection [P.00E-2](#). The input signal from the driver's door lock actuator switch should be able to be checked and the functions, which are described in the "Technical Description (comment)," should work normally.

**CONNECTOR: C-81**  
JUNCTION BLOCK  
(FRONT VIEW)

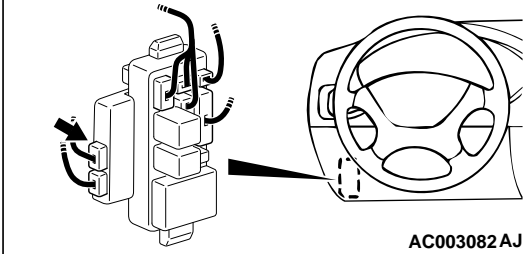

**CONNECTOR: E-15**  
DOOR

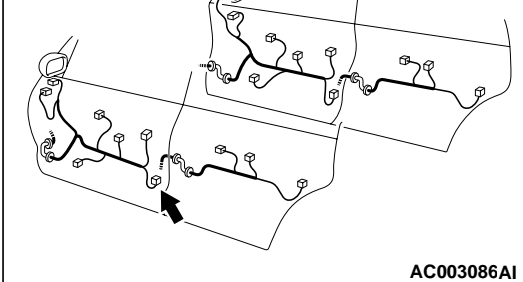

**CONNECTOR: C-68**  
CONNECTOR  
BLOCK (LH)

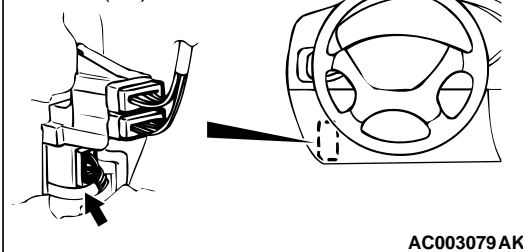

**STEP 7. Check the harness wires between driver's door lock actuator switch connector E-15 and ETACS-ECU connector C-81.**

**NOTE:** After checking intermediate connector C-68, check the wires. If intermediate connector C-68 is damaged, repair or replace it. Refer to GROUP 00E, Harness Connector Inspection [P.00E-2](#).

**Q: Are the harness wires between driver's door lock actuator switch connector E-15 and ETACS-ECU connector C-81 in good condition?**

**YES :** Replace the ETACS-ECU. The input signal from the driver's door lock actuator switch should be able to be checked and the functions, which are described in the "Technical Description (comment)," should work normally.

**NO :** Repair them. The input signal from the driver's door lock actuator switch should be able to be checked and the functions, which are described in the "Technical Description (comment)," should work normally.



**STEP 8. Check the front passenger's door lock actuator switch.**

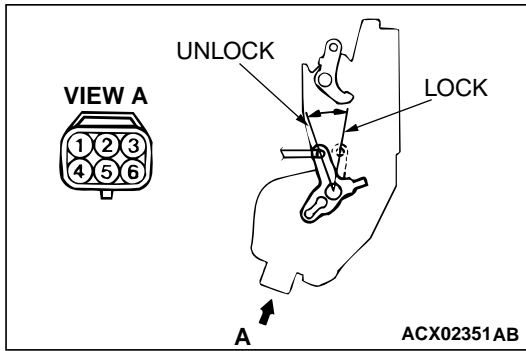

ROD POSITION	TESTER CONNECTION	SPECIFIED CONDITION
LOCK	1 – 3	No continuity
UNLOCK	2 – 3	Continuity

**Q: Is the front passenger's door lock actuator switch in good condition?**

**YES :** Go to Step 9.

**NO :** Replace it. The input signal from the front passenger's door lock actuator switch should be able to be checked and the functions, which are described in the "Technical Description (comment)," should work normally.

**STEP 9. Check the front passenger's door lock actuator switch ground circuit at front passenger's door lock actuator switch connector E-07.**

- (1) Disconnect front passenger's door lock actuator switch connector E-07 and measure at the harness side.
- (2) Measure the resistance between terminal 3 and ground.

**Q: Is the resistance less than 2 ohm?**

**YES :** Go to Step 12.

**NO :** Go to Step 10.

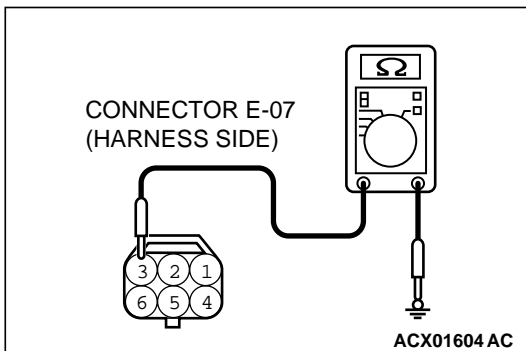

**STEP 10. Check front passenger's door lock actuator switch connector E-07 for damage.**

**Q: Is front passenger's door lock actuator switch connector E-07 in good condition?**

**YES :** Go to Step 11.

**NO :** Repair or replace it. Refer to GROUP 00E, Harness Connector Inspection. The input signal from the front passenger's door lock actuator switch should be able to be checked and the functions, which are described in the "Technical Description (comment)," should work normally.

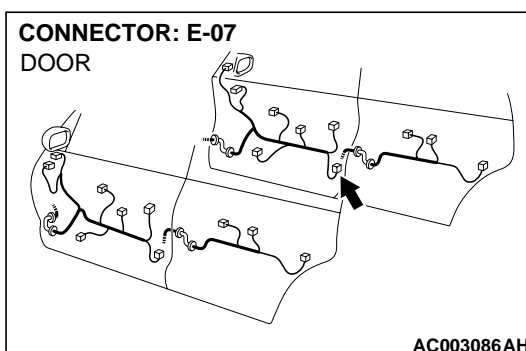

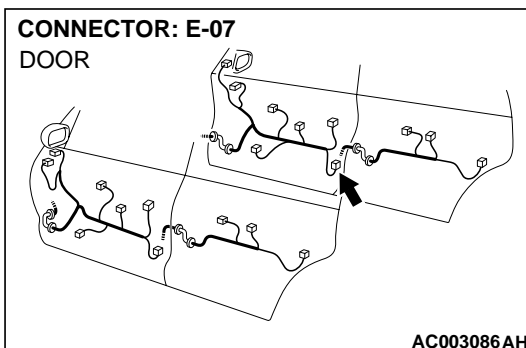
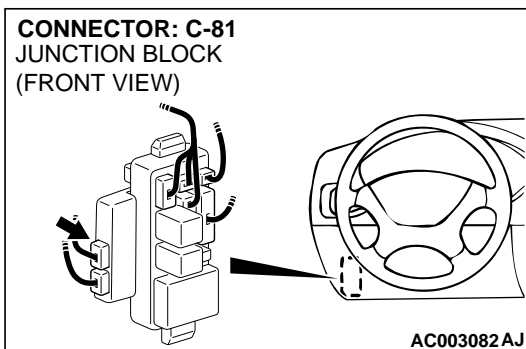
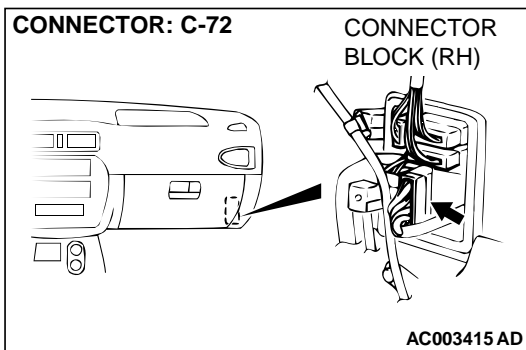
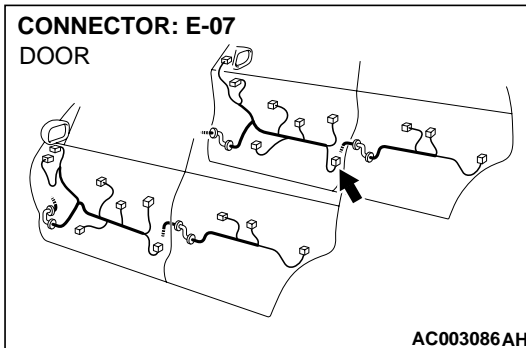

**STEP 11. Check the harness wires between front passenger's door lock actuator switch connector E-07 and ground.**

**NOTE:** After checking intermediate connector C-72, check the wires. If intermediate connector C-72 is damaged, repair or replace it. Refer to GROUP 00E, Harness Connector Inspection [P.00E-2](#).

**Q: Are the harness wires between front passenger's door lock actuator switch connector E-07 and ground in good condition?**

**YES :** There is no action to be taken.

**NO :** Repair them. The input signal from the front passenger's door lock actuator switch should be able to be checked and the functions, which are described in the "Technical Description (comment)," should work normally.

**STEP 12. Check the front passenger's door lock actuator switch connector E-07 and ETACS-ECU connector C-81 for damage.**

**Q:**

**YES :** Go to Step 13.

**NO :** Repair or replace them. Refer to GROUP 00E, Harness Connector Inspection [P.00E-2](#). The input signal from the front passenger's door lock actuator switch should be able to be checked and the functions, which are described in the "Technical Description (comment)," should work normally.

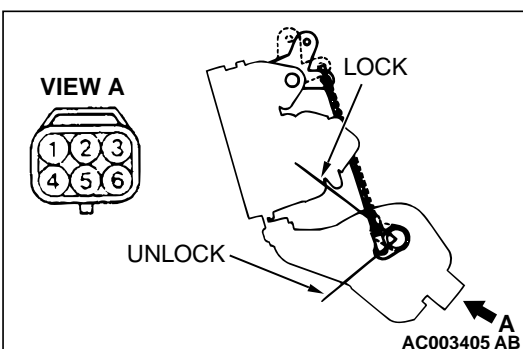
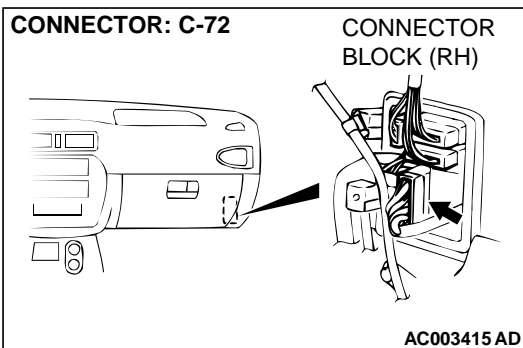
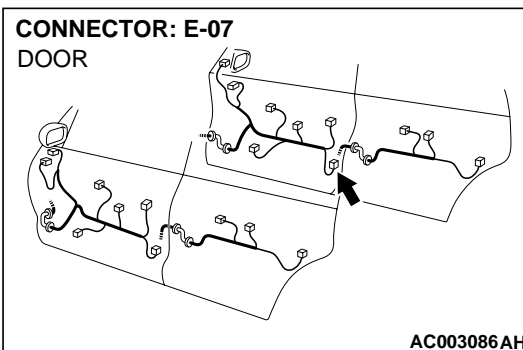
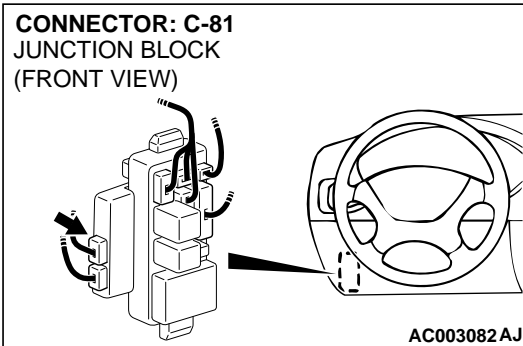

**STEP 13. Check the harness wires between front passenger's door lock actuator switch connector E-07 and ETACS-ECU connector C-81.**

*NOTE: After checking intermediate connector C-72, check the wires. If intermediate connector C-72 is damaged, repair or replace it. Refer to GROUP 00E, Harness Connector Inspection P.00E-2.*

**Q: Are the harness wires between front passenger's door lock actuator switch connector E-07 and ETACS-ECU connector C-81 in good condition?**

**YES :** Replace the ETACS-ECU. The input signal from the front passenger's door lock actuator switch should be able to be checked and the functions, which are described in the "Technical Description (comment)," should work normally.

**NO :** Repair them. The input signal from the front passenger's door lock actuator switch should be able to be checked and the functions, which are described in the "Technical Description (comment)," should work normally.

**STEP 14. Check the rear door lock actuator switch (LH).**

ROD POSITION	TESTER CONNECTION	SPECIFIED CONDITION
LOCK	1 - 2	Continuity
UNLOCK	1 - 3	Continuity

**Q: Is the rear door lock actuator switch (LH) in good condition?**

**YES :** Go to Step 15.

**NO :** Replace it. The input signal from the rear door lock actuator switch (LH) should be able to be checked and the functions, which are described in the "Technical Description (comment)," should work normally.

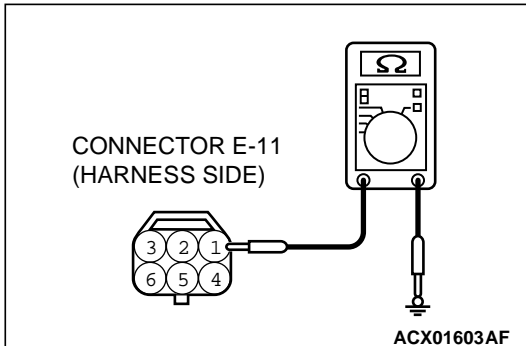

**STEP 15. Check the rear door lock actuator switch (LH) ground circuit at rear door lock actuator switch (LH) connector E-11**

- (1) Disconnect driver's door lock actuator switch connector E-11 and measure at the harness side.
- (2) Measure the resistance between terminal 1 and ground.

**Q: Is the resistance less than 2 ohm?**

**YES :** Go to Step 18.

**NO :** Go to Step 16.

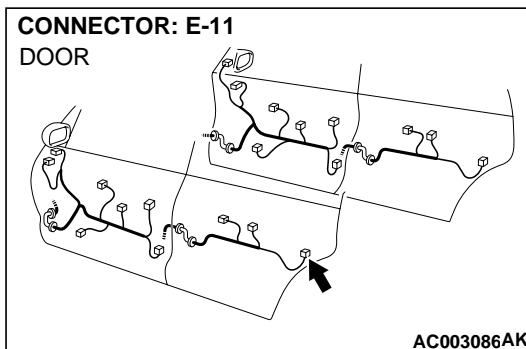

**STEP 16. Check rear door lock actuator switch (LH) connector E-11 for damage.**

**Q: Is rear door lock actuator switch (LH) connector E-11 in good condition?**

**YES :** Go to Step 17.

**NO :** Repair or replace it. Refer to GROUP 00E, Harness Connector Inspection. The input signal from the rear door lock actuator switch (LH) should be able to be checked and the functions, which are described in the "Technical Description (comment)," should work normally.

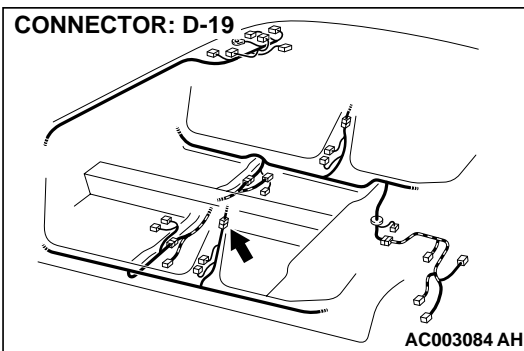
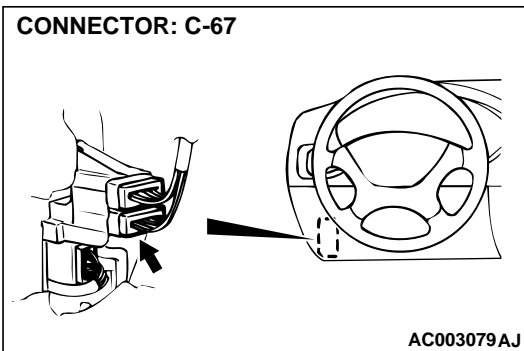
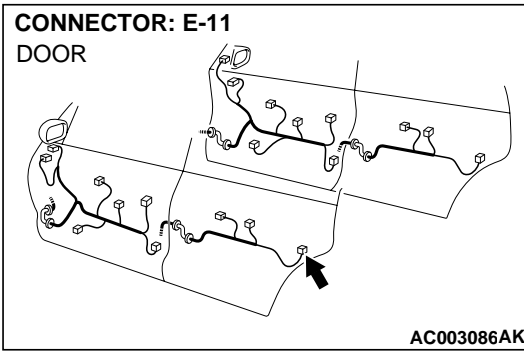

**STEP 17. Check the harness wires between rear door lock actuator switch (LH) connector E-11 and ground.**

*NOTE: After checking intermediate connector D-19, check the wires. If intermediate connector D-19 is damaged, repair or replace it. Refer to GROUP 00E, Harness Connector Inspection P.00E-2.*

**Q: Are the harness wires between rear door lock actuator switch (LH) connector E-11 and ground in good condition?**

**YES :** There is no action to be taken.

**NO :** Repair them. The input signal from the rear door lock actuator switch should be able to be checked and the functions, which are described in the "Technical Description (comment)," should work normally.

**STEP 18. Check the rear door lock actuator switch (LH) connector E-11 and ETACS-ECU connector C-81 for damage.**

**Q:**

**YES :** Go to Step 19.

**NO :** Repair or replace them. Refer to GROUP 00E, Harness Connector Inspection [P.00E-2](#). The input signal from the rear door lock actuator switch (LH) should be able to be checked and the functions, which are described in the "Technical Description (comment)," should work normally.

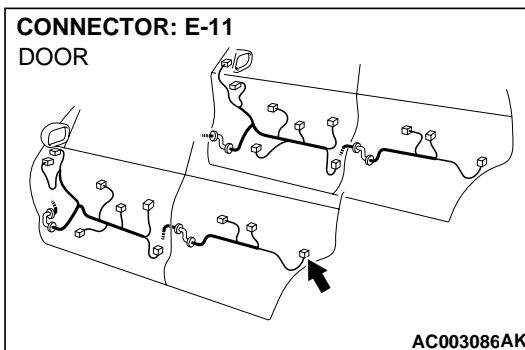
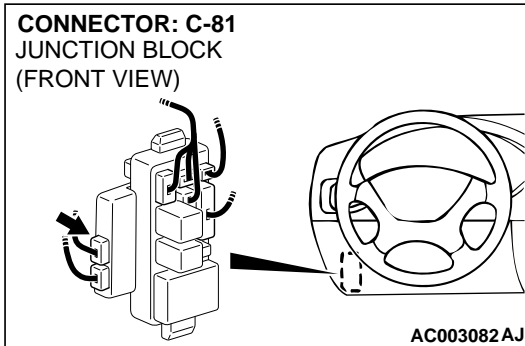

**STEP 19. Check the harness wires between rear door lock actuator switch (LH) connector E-11 and ETACS-ECU connector C-81.**

*NOTE: After checking intermediate connector C-67 and D-19, check the wires. If intermediate connector C-67 and D-19 are damaged, repair or replace it. Refer to GROUP 00E, Harness Connector Inspection [P.00E-2](#).*

**Q: Are the harness wires between rear door lock actuator switch (LH) connector E-11 and ETACS-ECU connector C-81 in good condition?**

**YES :** Replace the ETACS-ECU. The input signal from the rear door lock actuator switch (LH) should be able to be checked and the functions, which are described in the "Technical Description (comment)," should work normally.

**NO :** Repair them. The input signal from the rear door lock actuator switch (LH) should be able to be checked and the functions, which are described in the "Technical Description (comment)," should work normally.

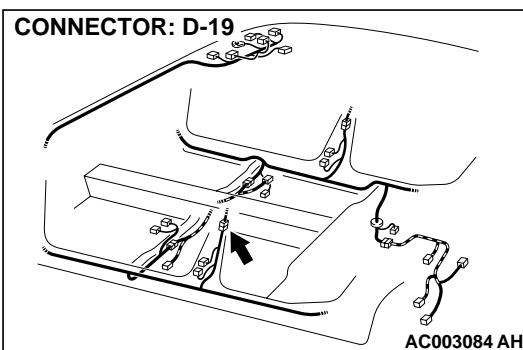
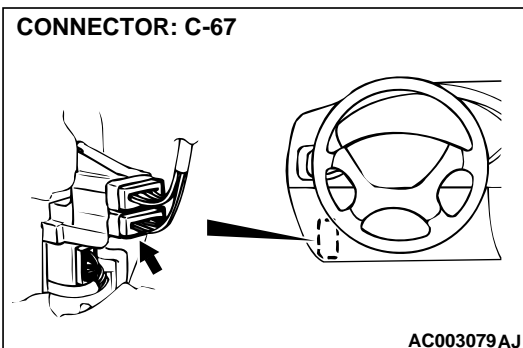
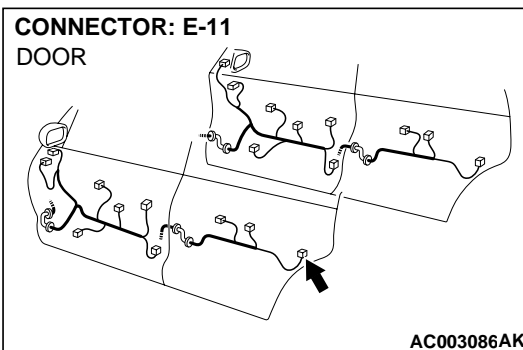
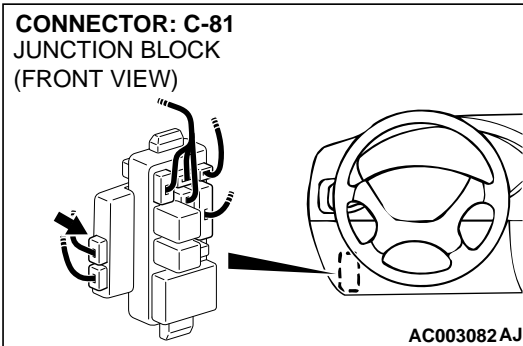

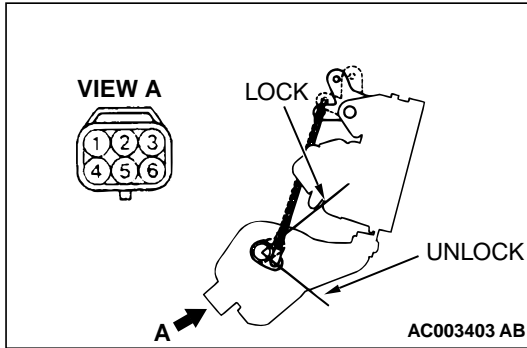
**STEP 20. Check the rear door lock actuator switch (RH).**

ROD POSITION	TESTER CONNECTION	SPECIFIED CONDITION
LOCK	1 – 2	No continuity
UNLOCK	1 – 3	Continuity

**Q: Is the rear door lock actuator switch (RH) in good condition?****YES** : Go to Step 21.**NO** : Replace it. The input signal from the rear door lock actuator switch (RH) should be able to be checked and the functions, which are described in the "Technical Description (comment)," should work normally.**STEP 21. Check the rear door lock actuator switch (RH) ground circuit at rear door lock actuator switch connector E-10.**

- (1) Disconnect rear door lock actuator switch (RH) connector E-10 and measure at the harness side.
- (2) Measure the resistance between terminal 1 and ground.

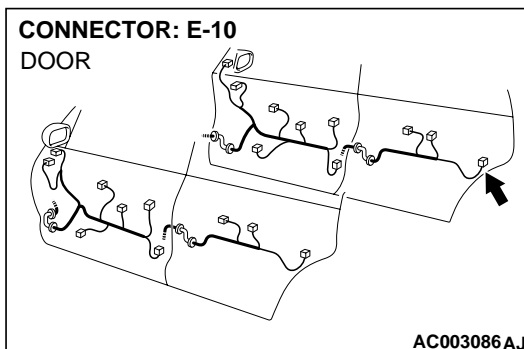
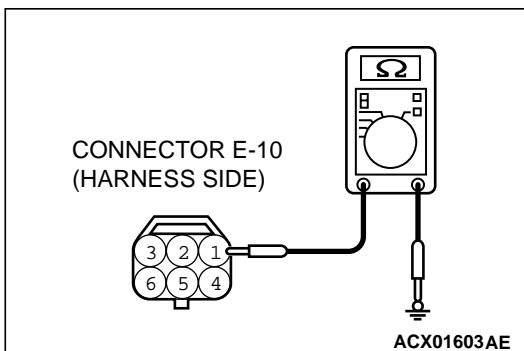
**Q: Is the resistance less than 2 ohm?****YES** : Go to Step 24.**NO** : Go to Step 22.**STEP 22. Check rear door lock actuator switch (RH) connector E-10 for damage.****Q: Is rear door lock actuator switch (RH) connector E-10 in good condition?****YES** : Go to Step 23.**NO** : Repair or replace it. Refer to GROUP 00E, Harness Connector Inspection. The input signal from the rear door lock actuator switch (RH) should be able to be checked and the functions, which are described in the "Technical Description (comment)," should work normally.



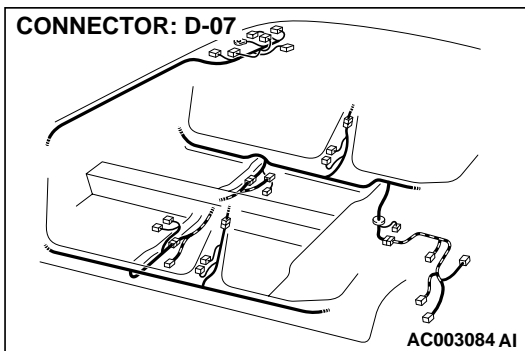
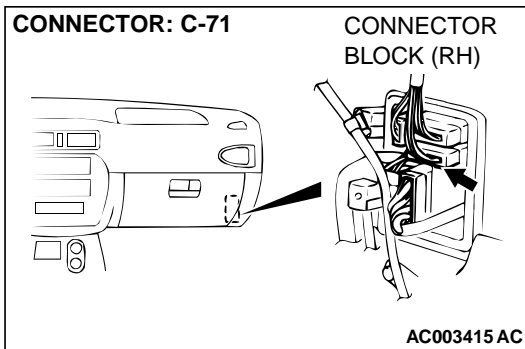
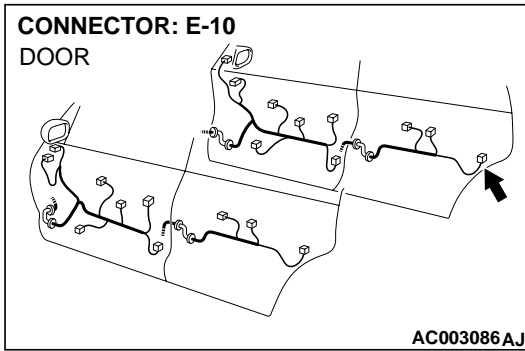

**STEP 23. Check the harness wires between rear door lock actuator switch (RH) connector E-10 and ground.**

**NOTE:** After checking intermediate connector D-07, check the wires. If intermediate connector D-07 is damaged, repair or replace it. Refer to GROUP 00E, Harness Connector Inspection [P.00E-2](#).

**Q: Are the harness wires between rear door lock actuator switch (RH) connector E-10 and ground in good condition?**

**YES :** There is no action to be taken.

**NO :** Repair them. The input signal from the rear door lock actuator switch (RH) should be able to be checked and the functions, which are described in the "Technical Description (comment)," should work normally.

**STEP 24. Check the rear door lock actuator switch connector E-10 and ETACS-ECU connector C-81 for damage.**

**Q:**

**YES :** Go to Step 25.

**NO :** Repair or replace them. Refer to GROUP 00E, Harness Connector Inspection [P.00E-2](#). The input signal from the rear door lock actuator switch (RH) should be able to be checked and the functions, which are described in the "Technical Description (comment)," should work normally.

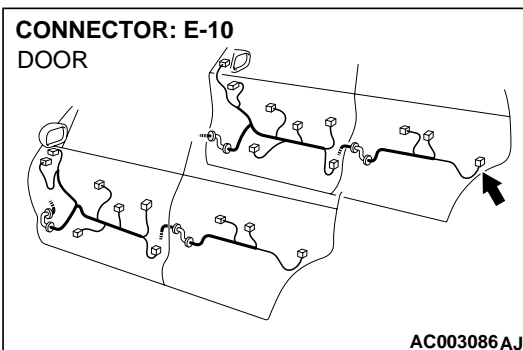
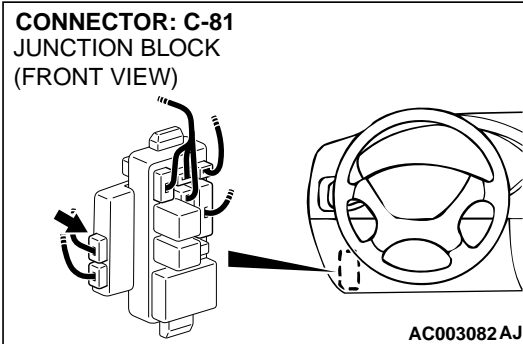

**CONNECTOR: C-81**  
JUNCTION BLOCK  
(FRONT VIEW)

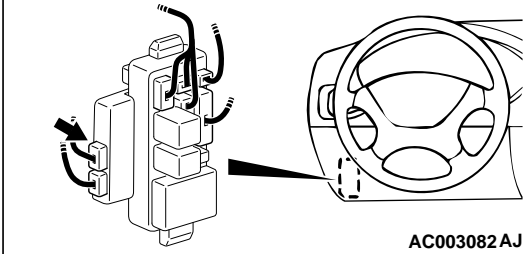

AC003082 AJ

**CONNECTOR: E-10**  
DOOR

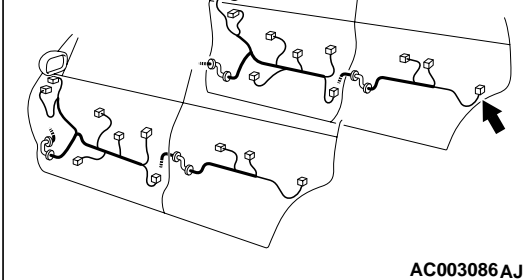

AC003086 AJ

**CONNECTOR: C-71**

CONNECTOR  
BLOCK (RH)

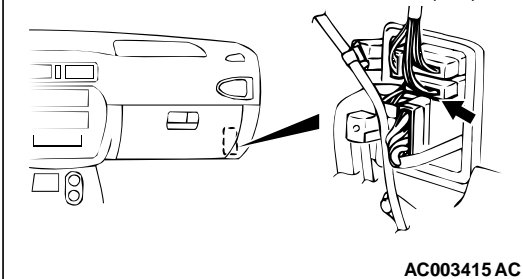

AC003415 AC

**CONNECTOR: D-07**

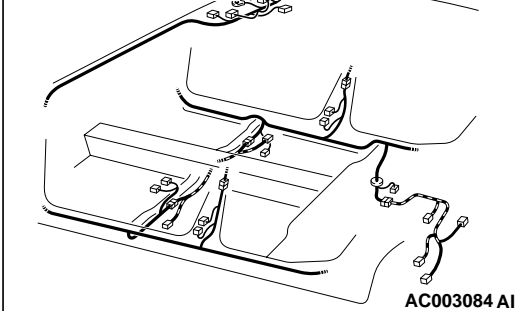

AC003084 AI

**STEP 25. Check the harness wires between rear door lock actuator switch (RH) connector E-10 and ETACS-ECU connector C-81.**

*NOTE: After checking intermediate connector C-71 and D-07, check the wires. If intermediate connector C-71 and D-07 is damaged, repair or replace it. Refer to GROUP 00E, Harness Connector Inspection [P.00E-2](#).*

**Q: Are the harness wires between rear door lock actuator switch (RH) connector E-10 and ETACS-ECU connector C-81 in good condition?**

**YES :** Replace the ETACS-ECU. The input signal from the rear door lock actuator switch (RH) should be able to be checked and the functions, which are described in the "Technical Description (comment)," should work normally.

**NO :** Repair them. The input signal from the rear door lock actuator switch (RH) should be able to be checked and the functions, which are described in the "Technical Description (comment)," should work normally.

Inspection Procedure N-10: The door lock switch (incorporated in power window main switch and power window sub switch) signal is not sent to the ETACS-ECU.

Door Lock Switch Input Circuit

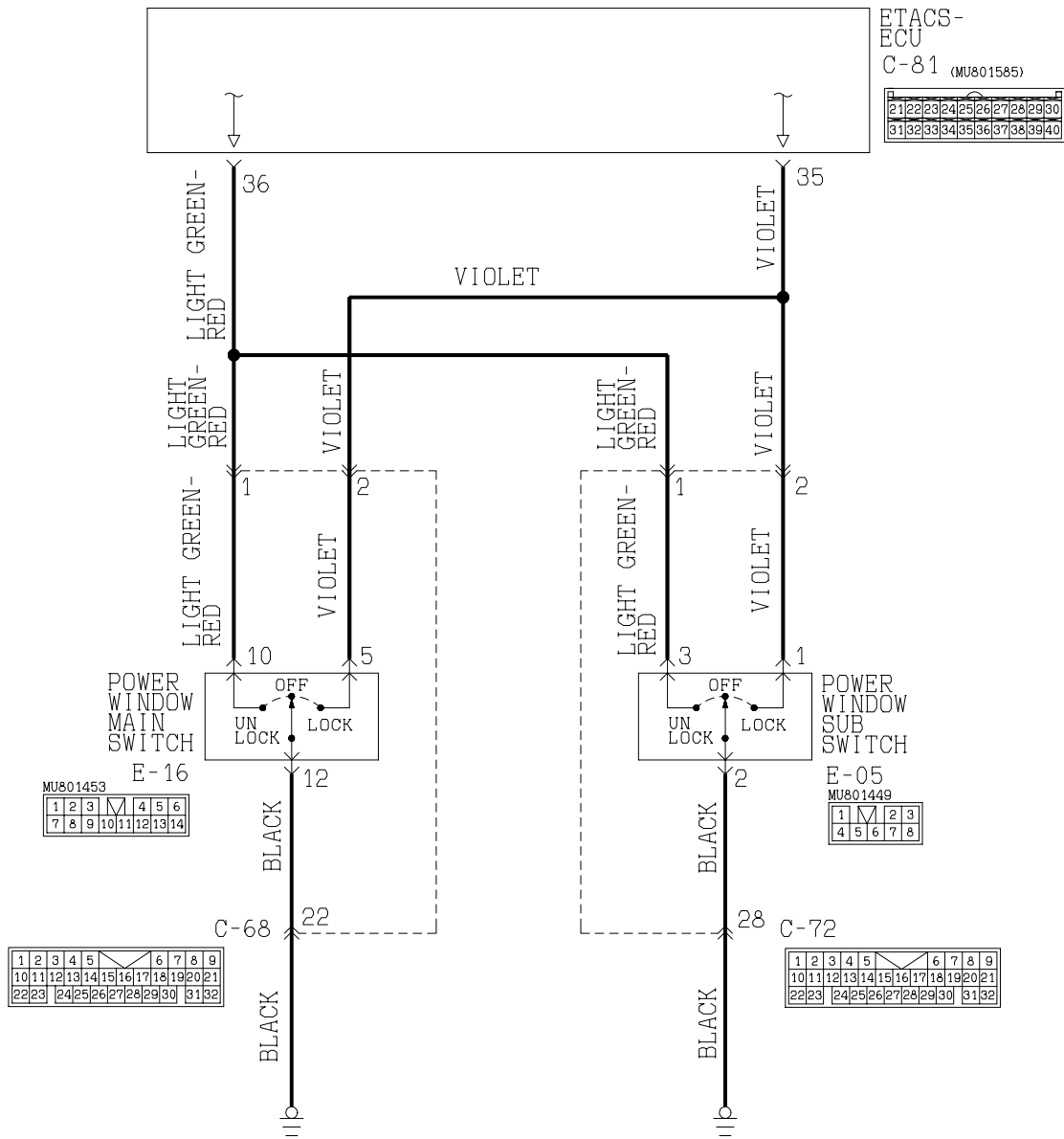

W1S09M31AA  
AC004244

TSB Revision

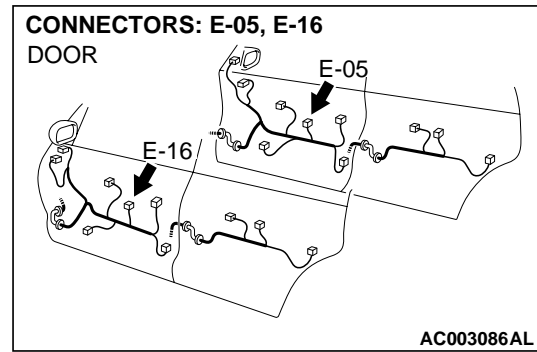
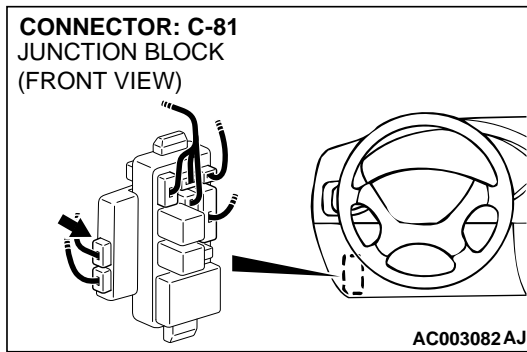
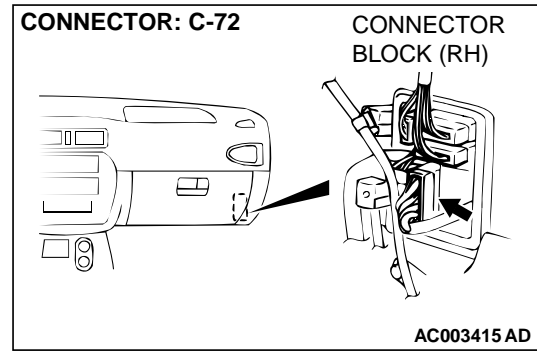
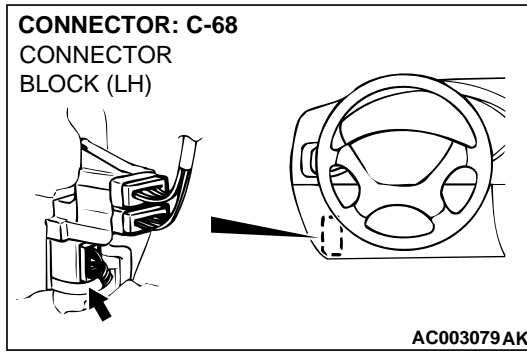

**CIRCUIT OPERATION**

The ETACS-ECU uses the input signal from the door lock switch to operate the central door locking system.

**TECHNICAL DESCRIPTION (COMMENT)**

The door lock switch input signal is used to operate the central door locking system. If the signal fails, the door will not be locked or unlocked when the door lock switch is operated.

**TROUBLESHOOTING HINTS**

- Malfunction of the power window main switch or power window sub switch (door lock switch)
- Malfunction of the ETACS-ECU
- Damaged harness wires or connectors

**DIAGNOSIS**

**Required Special Tools:**

- MB991223: Test Harness Set
- MB991502: Scan Tool (MUT-II)
- MB991529: Diagnostic Trouble Code Check Harness

**STEP 1. Check the location of malfunction.**

**Q: Which door lock switch signal is not input?**

**Power window main switch (Driver's door) :** Go to Step 2.

**Power window sub switch (Front passenger's door) :** Go to Step 8.

**STEP 2. Check the door lock switch (power window main switch).**

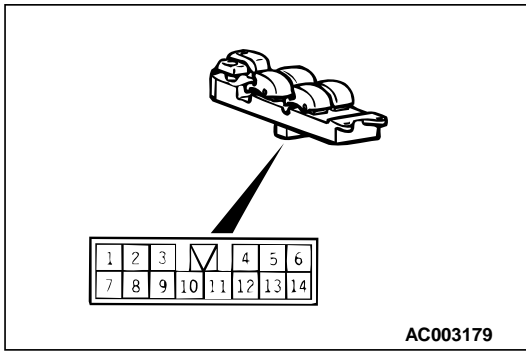

SWITCH POSITION	TESTER CONNECTION	SPECIFIED CONDITION
LOCK	5 – 10	Continuity
OFF	–	No continuity
UNLOCK	10 – 12	Continuity

**Q: Is the door lock switch (power window main switch) in good condition?**

**YES :** Go to Step 3.

**NO :** Replace the power window main switch. The door lock switch input signal should be able to be checked and the central door locking system should work normally.

**STEP 3. Check the power window main switch ground circuit at power window main switch connector E-16.**

- (1) Disconnect power window main switch connector E-16 and measure at the harness side.
- (2) Measure the resistance between terminal 12 and ground.

**Q: Is the resistance less than 2 ohm?**

**YES :** Go to Step 6.

**NO :** Go to Step 4.

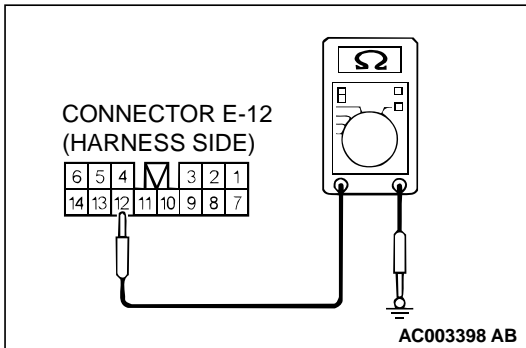

**STEP 4. Check power window main switch connector E-16 for damage.**

**Q: Is power window main switch connector E-16 in good condition?**

**YES :** Go to Step 5.

**NO :** Repair or replace it. Refer to GROUP 00E, Harness Connector Inspection [P.00E-2](#) . The door lock switch input signal should be able to be checked and the central door locking system should work normally.

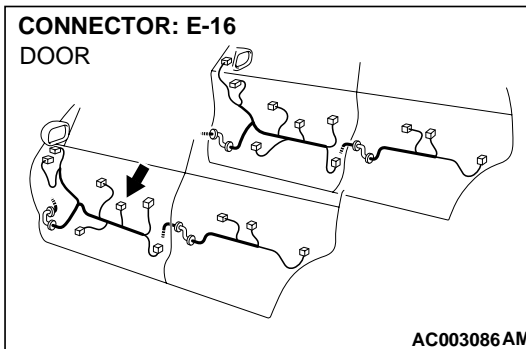

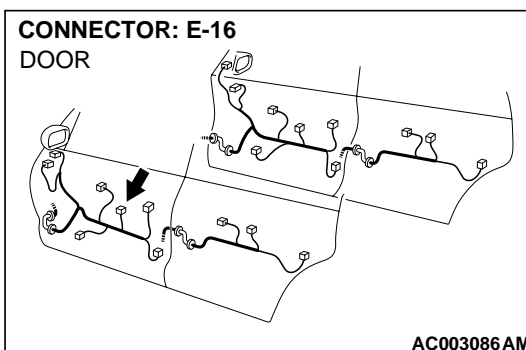
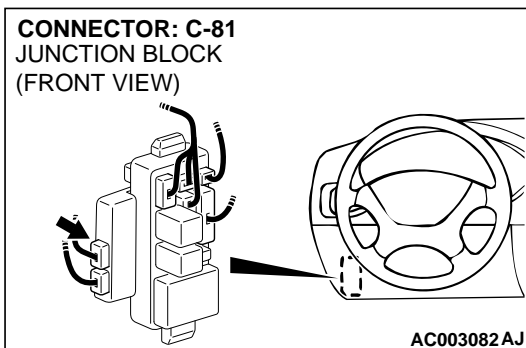
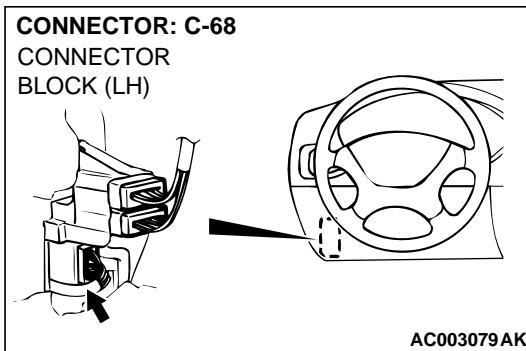
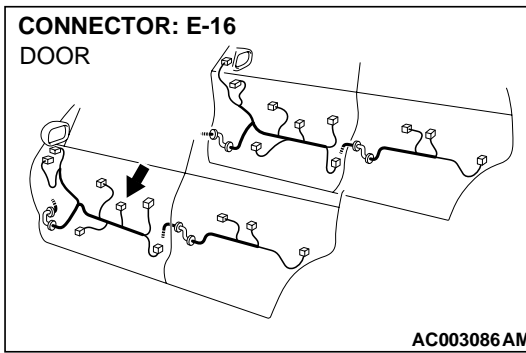

**STEP 5. Check the harness wires between power window main switch connector E-16 and ground.**

*NOTE: After checking intermediate connector C-68, check the wires. If intermediate connector C-68 is damaged, repair or replace it. Refer to GROUP 00E, Harness Connector Inspection.*

**Q: Are the harness wires between power window main switch connector E-16 and ground in good condition?**

**YES :** There is no action to be taken.

**NO :** Repair them. The door lock switch input signal should be able to be checked and the central door locking system should work normally.

**STEP 6. Check the power window main switch connector E-16 and ETACS-ECU connector C-81 for damage.**

**Q: Are power window main switch connector E-16 and ETACS-ECU connector C-81 in good condition?**

**YES :** Go to Step 7.

**NO :** Repair or replace them. Refer to GROUP 00E, Harness Connector Inspection [P.00E-2](#) . The door lock switch input signal should be able to be checked and the central door locking system should work normally.

**CONNECTOR: C-81**  
JUNCTION BLOCK  
(FRONT VIEW)

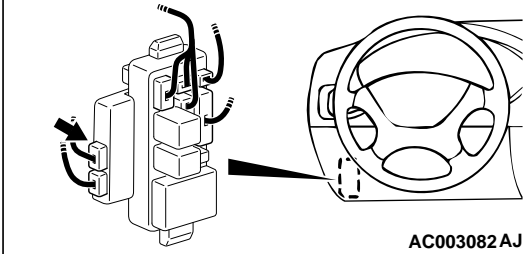

**CONNECTOR: E-16**  
DOOR

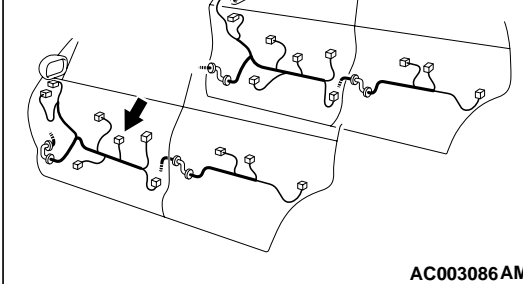

**CONNECTOR: C-68**  
CONNECTOR  
BLOCK (LH)

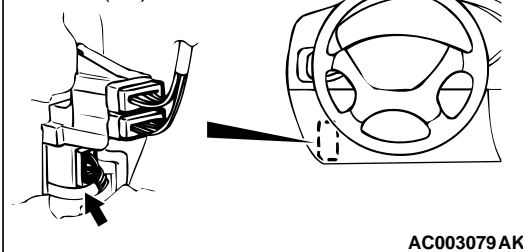

**STEP 7. Check the harness wires between power window main switch connector E-16 and ETACS-ECU connector C-81.**

*NOTE: After checking intermediate connector C-68, check the wires. If intermediate connector C-68 is damaged, repair or replace it. Refer to GROUP 00E, Harness Connector Inspection P.00E-2 .*

**Q: Are the harness wires between power window main switch connector E-16 and ETACS-ECU connector C-81 in good condition?**

**YES :** Replace the ETACS-ECU. The door lock switch input signal should be able to be checked and the central door locking system should work normally.

**NO :** Repair them. The door lock switch input signal should be able to be checked and the central door locking system should work normally.

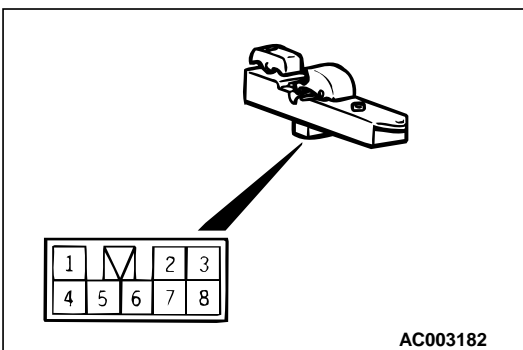

**STEP 8. Check the door lock switch (power window sub switch).**

SWITCH POSITION	TESTER CONNECTION	SPECIFIED CONDITION
LOCK	1 – 2	Continuity
OFF	–	No continuity
UNLOCK	2 – 3	Continuity

**Q: Is the door lock switch (power window sub switch) in good condition?**

**YES :** Go to Step 9.

**NO :** Replace the power window sub switch. The door lock switch input signal should be able to be checked and the central door locking system should work normally.



**STEP 9. Check the power window sub switch ground circuit at power window sub switch connector E-05.**

- (1) Disconnect power window sub switch connector E-05 and measure at the harness side.
- (2) Measure the resistance between terminal 2 and ground.

**Q: Is the resistance less than 2 ohm?**

**YES :** Go to Step 12.

**NO :** Go to Step 10.

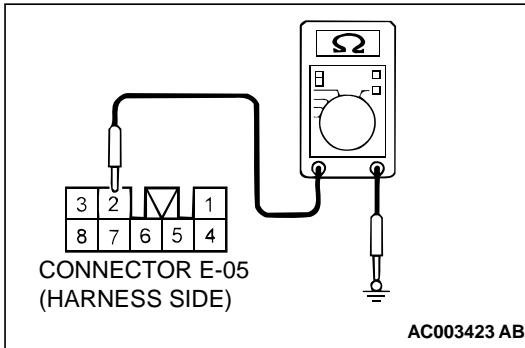

**STEP 10. Check power window sub switch connector E-05 for damage.**

**Q: Is power window sub switch connector E-05 in good condition?**

**YES :** Go to Step 11.

**NO :** Repair or replace it. Refer to GROUP 00E, Harness Connector Inspection [P.00E-2](#) . The door lock switch input signal should be able to be checked and the central door locking system should work normally.

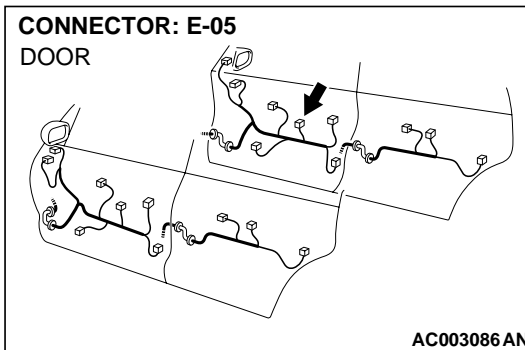

**STEP 11. Check the harness wires between power window sub switch connector E-05 and ground.**

**NOTE:** After checking intermediate connector C-72, check the wires. If intermediate connector C-72 is damaged, repair or replace it. Refer to GROUP 00E, Harness Connector Inspection.

**Q: Are the harness wires between power window sub switch connector E-05 and ground in good condition?**

**YES :** There is no action to be taken.

**NO :** Repair them. The door lock switch input signal should be able to be checked and the central door locking system should work normally.

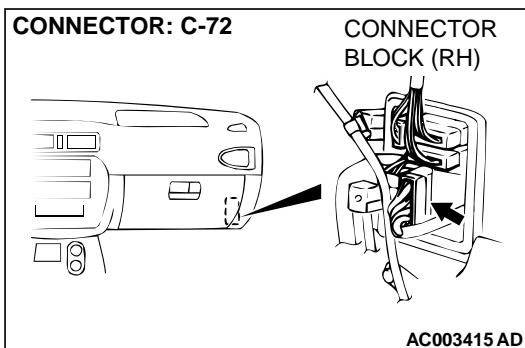
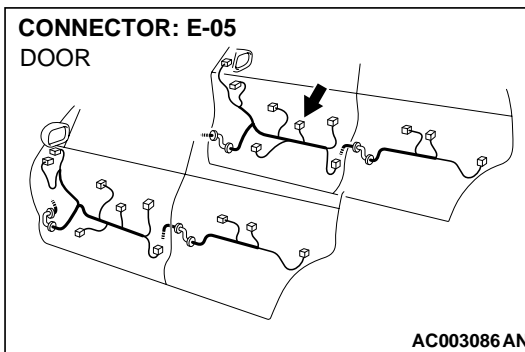

**STEP 12. Check the power window sub switch connector E-05 and ETACS-ECU connector C-81 for damage.**

**Q:**

**YES :** Go to Step 13.

**NO :** Repair or replace them. Refer to GROUP 00E, Harness Connector Inspection [P.00E-2](#) . The door lock switch input signal should be able to be checked and the central door locking system should work normally.

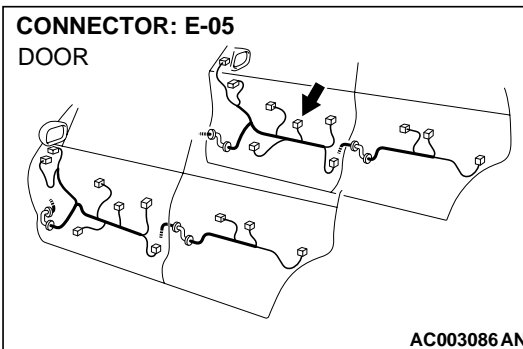
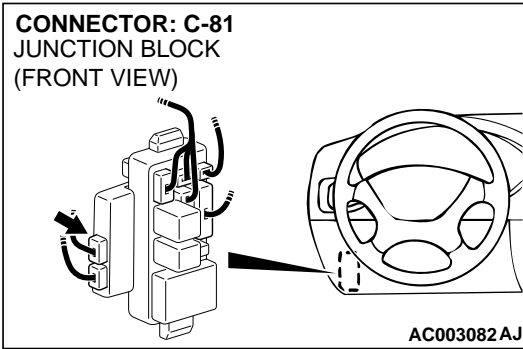

**CONNECTOR: C-81**  
JUNCTION BLOCK  
(FRONT VIEW)

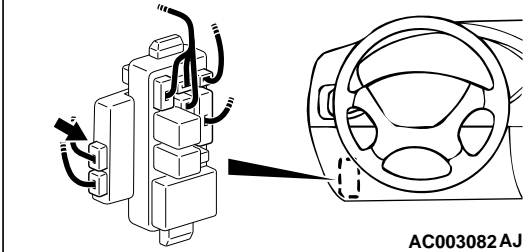

**CONNECTOR: E-05**  
DOOR

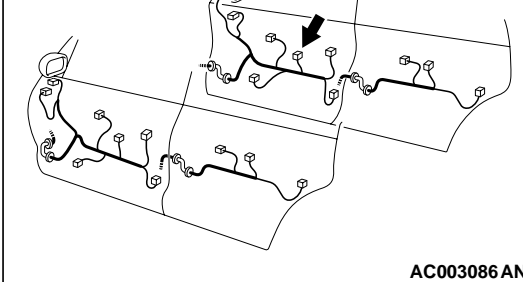

**CONNECTOR: C-72**

CONNECTOR  
BLOCK (RH)

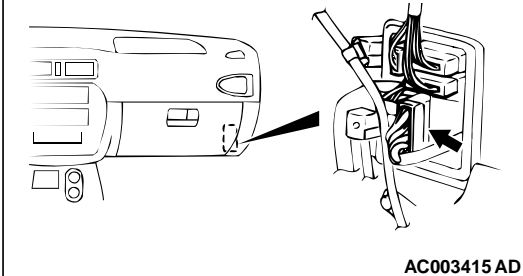

**STEP 13. Check the harness wires between power window sub switch connector E-05 and ETACS-ECU connector C-81.**

*NOTE: After checking intermediate connector C-72, check the wires. If intermediate connector C-72 is damaged, repair or replace it. Refer to GROUP 00E, Harness Connector Inspection P.00E-2 .*

**Q: Are the harness wires between power window sub switch connector E-05 and ETACS-ECU connector C-81 in good condition?**

**YES :** Replace the ETACS-ECU. The door lock switch input signal should be able to be checked and the central door locking system should work normally.

**NO :** Repair them. The door lock switch input signal should be able to be checked and the central door locking system should work normally.

Inspection Procedure N-11: The Hood switch signal is not sent to the ETACS-ECU.

Hood Switch Input Circuit

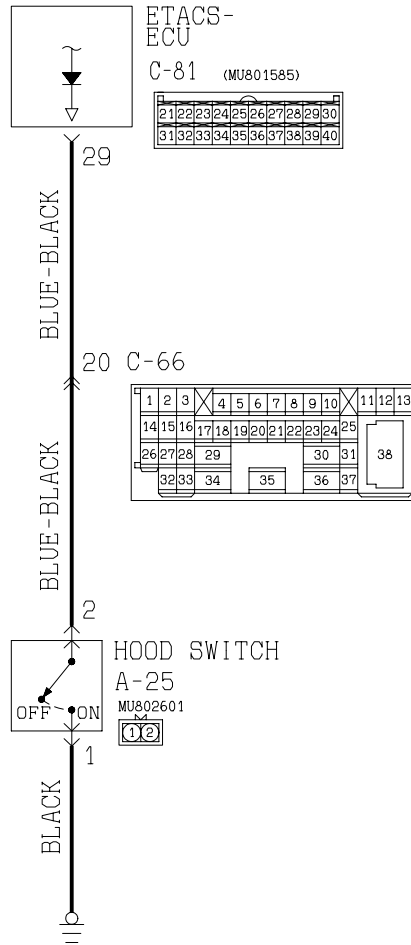

W1S09M32AA  
AC004245

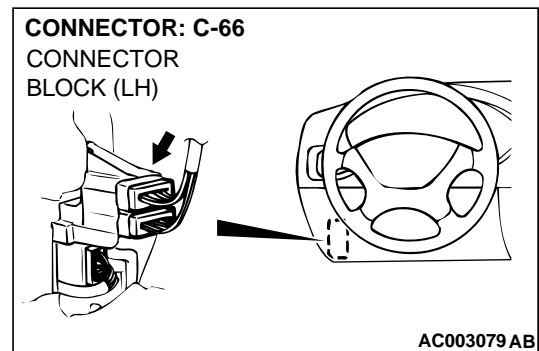
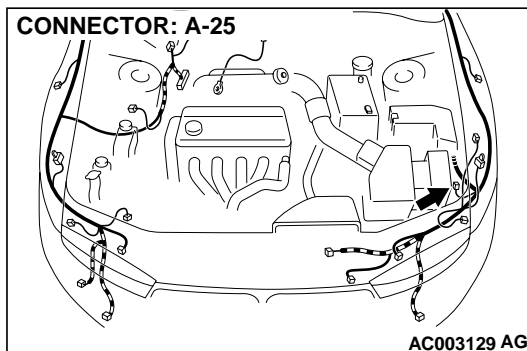

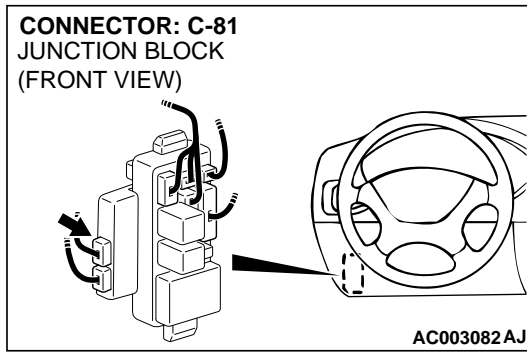

**CIRCUIT OPERATION**

The ETACS-ECU operates the hood switch according to the input signal from the theft-alarm system switch.

**TROUBLESHOOTING HINTS**

- Malfunction of the hood switch
- Malfunction of the ETACS-ECU
- Damaged harness wires or connectors

**TECHNICAL DESCRIPTION (COMMENT)**

The theft-alarm system will not work normally if the hood switch input signal is an error.

**DIAGNOSIS**

**Required Special Tools:**

- MB991223: Test Harness Set
- MB991502: Scan Tool (MUT-II)
- MB991529: Diagnostic Trouble Code Check Harness

**STEP 1. Check the hood switch.**

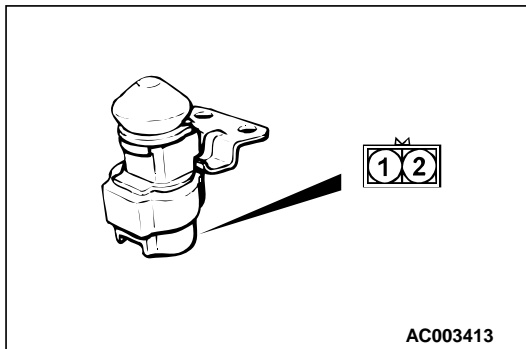

SWITCH POSITION	TESTER CONNECTION	SPECIFIED CONDITION
Released	–	No continuity
Pressed	1 – 2	Continuity

**Q: Is the hood switch in good condition?**

**YES** : Go to Step 2.

**NO** : Repair it. The hood switch input signal should be able to be checked and the theft-alarm should work normally.

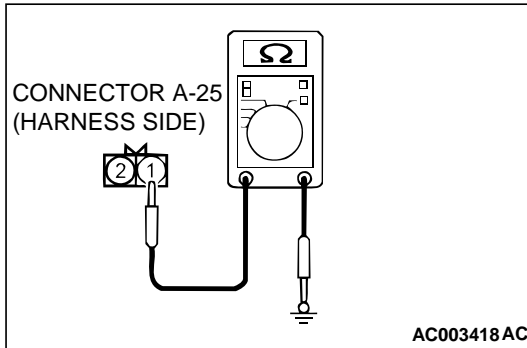

**STEP 2. Check the hood switch ground circuit at the hood switch connector A-25.**

- (1) Disconnect the hood switch connector A-25 and measure at the harness side.
- (2) Measure the resistance between terminal 1 and ground.

**Q: Is the resistance less than 2 ohm?**

**YES :** Go to Step 5.

**NO :** Go to Step 3.

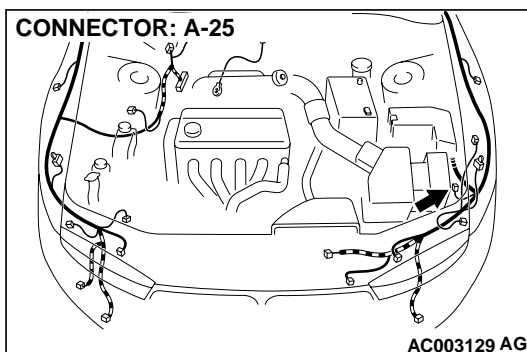

**STEP 3. Check hood switch connector A-25 for damage.**

**Q: Is hood switch connector A-25 in good condition?**

**YES :** Go to Step 4.

**NO :** Repair or replace it. Refer to GROUP 00E, Harness Connector Inspection [P.00E-2](#) . The hood switch input signal should be able to be checked and the theft-alarm system should work normally.

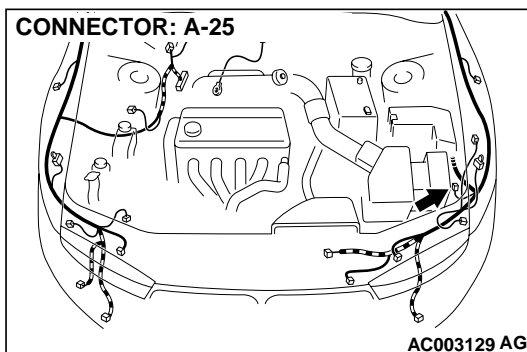

**STEP 4. Check the harness wires between hood switch connector A-25 and ground.**

**Q: Are the harness wires between hood switch connector A-25 and ground in good condition?**

**YES :** There is no action to be taken.

**NO :** Repair them. The hood switch input signal should be able to be checked and the theft-alarm system should work normally.

**STEP 5. Check hood switch connector A-25 and ETACS-ECU connector C-81 for damage.**

**Q: Are hood switch connector A-25 and ETACS-ECU connector C-81 in good condition?**

**YES :** Go to Step 6.

**NO :** Repair or replace them. Refer to GROUP 00E, Harness Connector Inspection [P.00E-2](#) . The hood switch input signal should be able to be checked and the theft-alarm system should work normally.

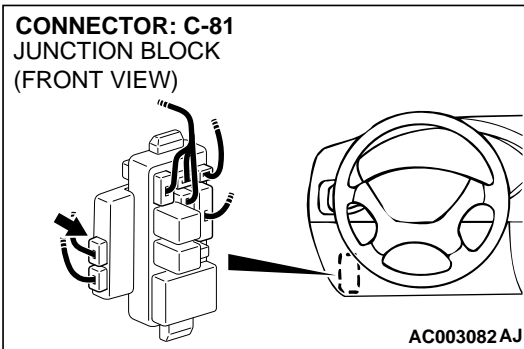
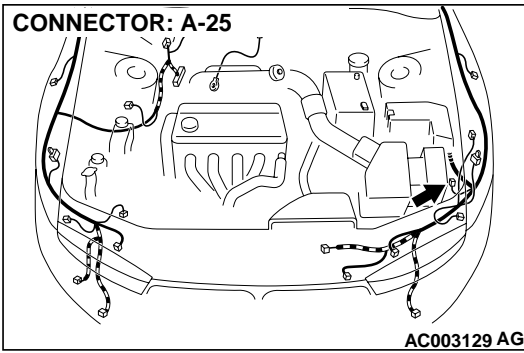

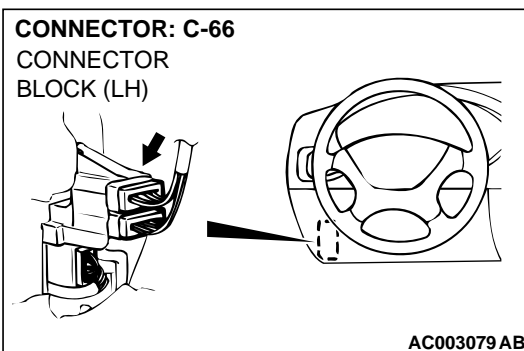
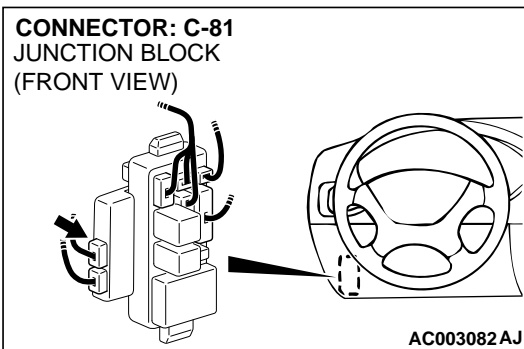
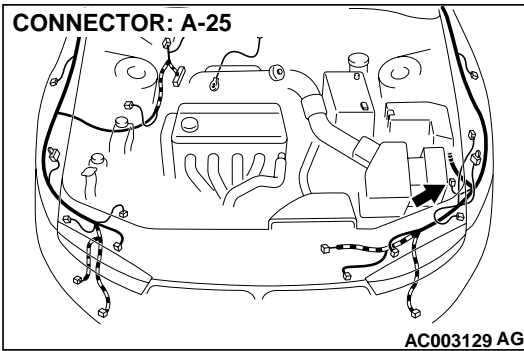

**STEP 6. Check the harness wire between hood switch connector A-25 and ETACS-ECU connector C-81.**

**NOTE:** After checking intermediate connector C-66, check the wires. If intermediate connector C-66 is damaged, repair or replace it. Refer to GROUP 00E, Harness Connector Inspection P.00E-2.

**Q: Is the harness wire between hood switch connector A-25 and ETACS-ECU connector C-81 in good condition?**

**YES :** Replace the ETACS-ECU. The hood switch input signal should be able to be checked and the theft-alarm system should work normally.

**NO :** Repair it. The hood switch input signal should be able to be checked and the theft-alarm should work normally.



**k Inspection Procedure N-12: The trunk lid latch switch signal is not sent to the ETACS-ECU.**

Trunk Lid Latch Switch Input Circuit

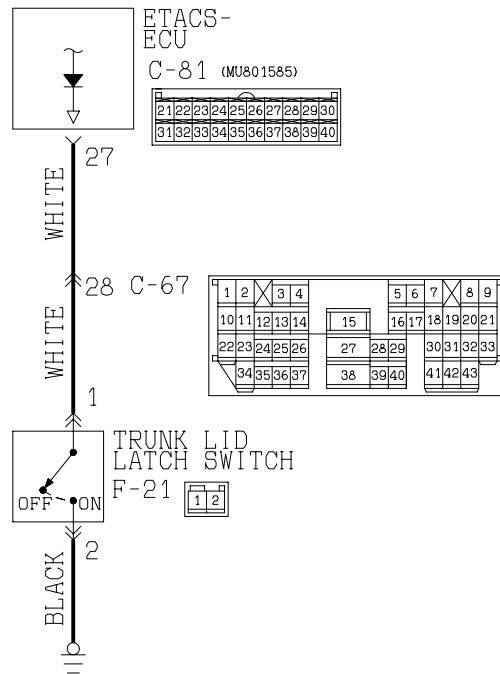

W1809M33AA

AC004246

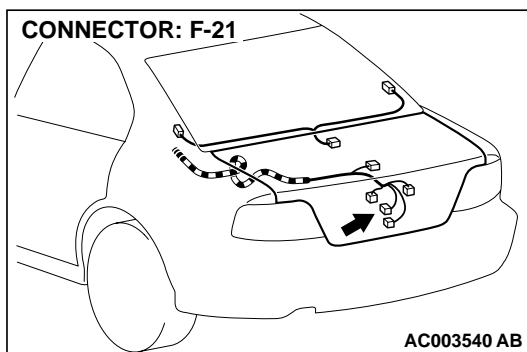
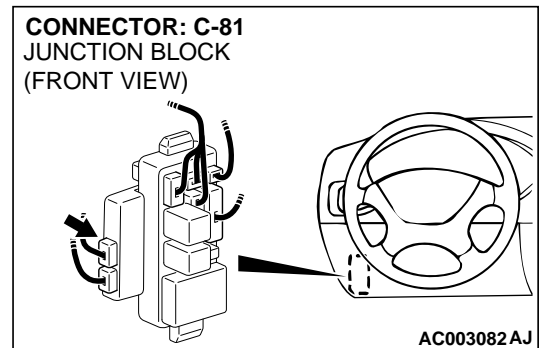
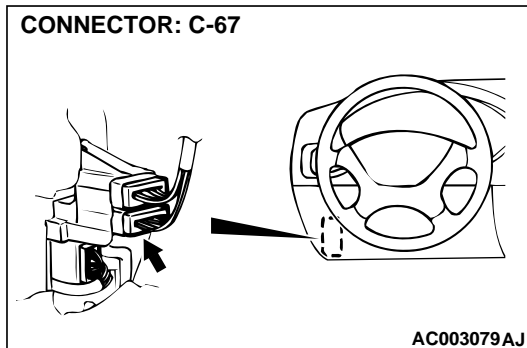

**CIRCUIT OPERATION**

The ETACS-ECU uses the input signal from the trunk lid latch switch to operate the following functions.

**TECHNICAL DESCRIPTION (COMMENT)**

The trunk lid latch switch input signal is used to operate the theft-alarm system. If the signal fails, these function will not work normally.

**TROUBLESHOOTING HINTS**

- Malfunction of the trunk lid latch
- Malfunction of the ETACS-ECU
- Damaged harness wires or connectors

**DIAGNOSIS**

**Required Special Tools:**

- MB991223: Harness Set
- MB991502: Scan Tool (MUT-II)
- MB991529: Diagnostic Trouble Code Check Harness

**STEP 1. Check the trunk lid latch switch.**

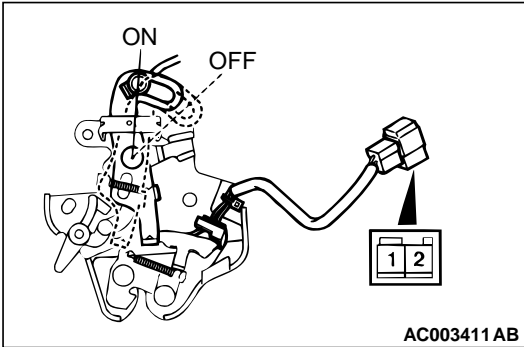

SWITCH POSITION	TESTER CONNECTION	SPECIFIED CONDITION
LOCK	–	No continuity
UNLOCK	1 – 2	Continuity

**Q: Is the trunk lid latch switch in good condition?**

**YES :** Go to Step 2.

**NO :** Replace it. The input signal from the trunk lid latch switch should be able to be checked and the functions, which are described in the "Technical Description (comment)," should work normally.

**STEP 2. Check the trunk lid latch switch ground circuit at trunk lid latch switch connector F-21.**

- (1) Disconnect trunk lid latch switch connector F-21 and measure at the harness side.
- (2) Measure the resistance between terminal 2 and ground.

**Q: Is the resistance less than 2 ohm?**

**YES :** Go to Step 5.

**NO :** Go to Step 3.

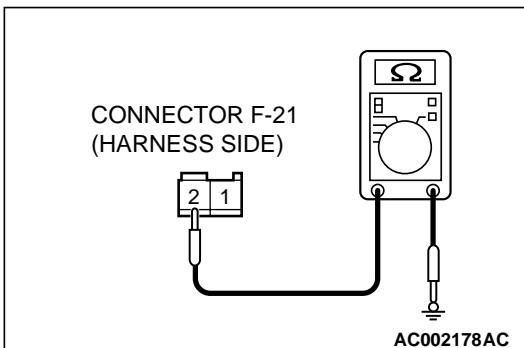

**STEP 3. Check trunk lid latch switch connector F-21 for damage.**

**Q: Is trunk lid latch switch connector F-21 in good condition?**

**YES :** Go to Step 4.

**NO :** Repair or replace it. Refer to GROUP 00E, Harness Connector Inspection P.00E-2 . The input signal from the trunk lid latch switch should be able to be checked and the functions, which are described in the "Technical Description (comment)," should work normally.

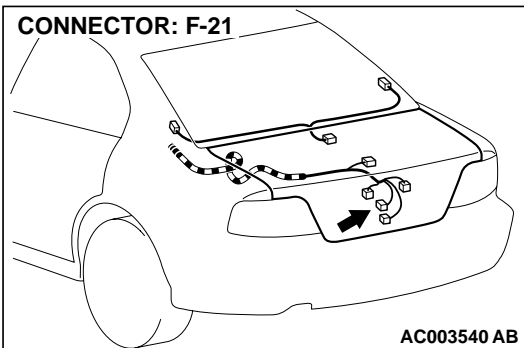

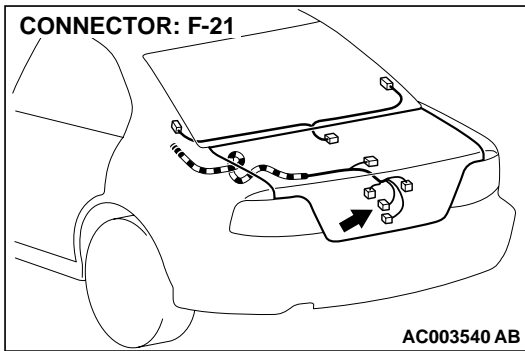

**STEP 4. Check the harness wire between trunk lid latch switch connector F-21 and ground.**

**Q: Is the harness wire between trunk lid latch switch connector F-21 and ground in good condition?**

**YES :** There is no action to be taken.

**NO :** Repair it. The input signal from the trunk lid latch switch should be able to be checked and the functions, which are described in the "Technical Description (comment)," should work normally.

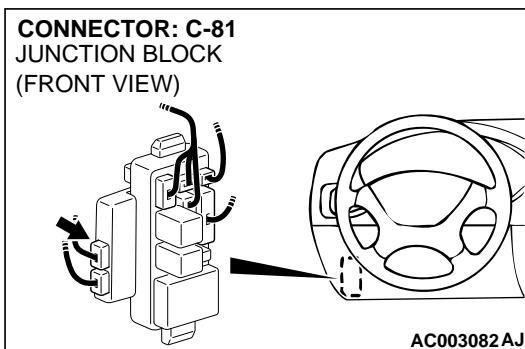

**STEP 5. Check trunk lid latch switch connector F-21 and ETACS-ECU connector C-81 for damage.**

**Q: Are trunk lid latch switch connector F-05 and ETACS-ECU connector C-81 in good condition?**

**YES :** Go to Step 6.

**NO :** Repair or replace them. Refer to GROUP 00E, Harness Connector Inspection [P.00E-2](#) . The input signal from the trunk lid latch switch should be able to be checked and the functions, which are described in the "Technical Description (comment)," should work normally.

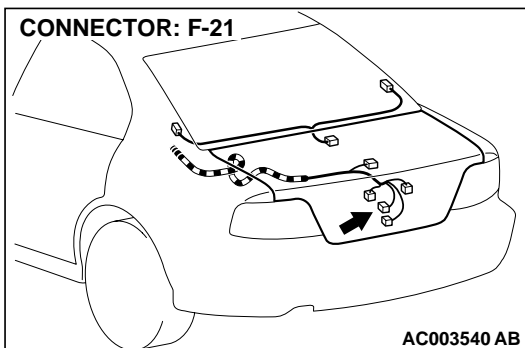

**CONNECTOR: C-81**  
JUNCTION BLOCK  
(FRONT VIEW)

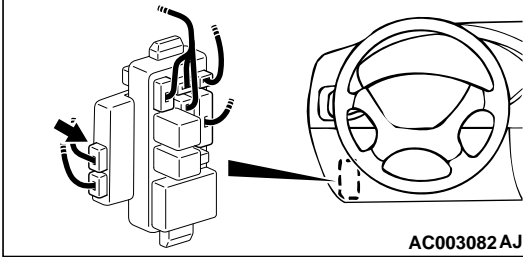

**CONNECTOR: F-21**

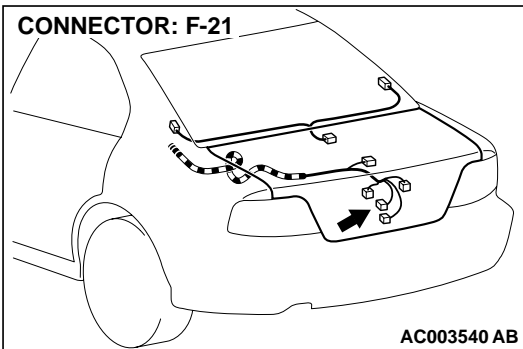

**CONNECTOR: C-67**

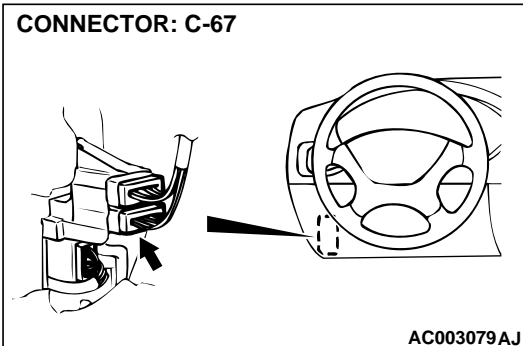

**STEP 6. Check the harness wires between trunk lid latch switch connector F-21 and ETACS-ECU connector C-81.**  
*NOTE: After checking intermediate connector C-67, check the wires. If intermediate connector C-67 is damaged, repair or replace it. Refer to GROUP 00E, Harness Connector Inspection P.00E-2 .*

**Q: Are the harness wires between trunk lid latch switch connector F-21 and ETACS-ECU connector C-81 in good condition?**

**YES :** Replace the ETACS-ECU. The input signal from the trunk lid latch switch should be able to be checked and the functions, which are described in the "Technical Description (comment)," should work normally.

**NO :** Repair them. The input signal from the trunk lid latch switch should be able to be checked and the functions, which are described in the "Technical Description (comment)," should work normally.

Inspection Procedure N-13: The trunk lid lock key cylinder switch signal is not sent to the ETACS-ECU.

Trunk lid Lock Key Cylinder Switch Input Circuit

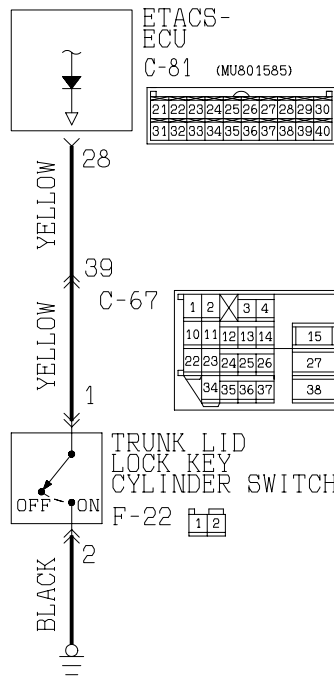

W1S09M34AA  
AC004247

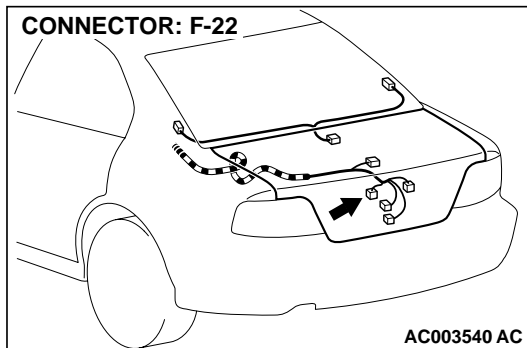
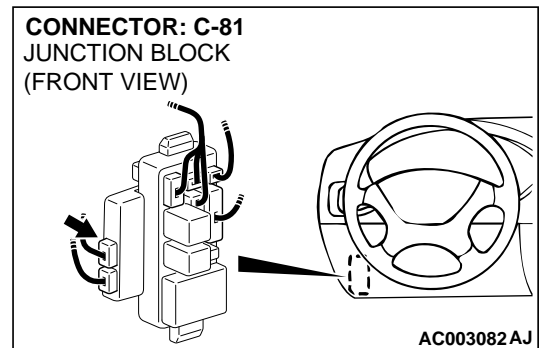
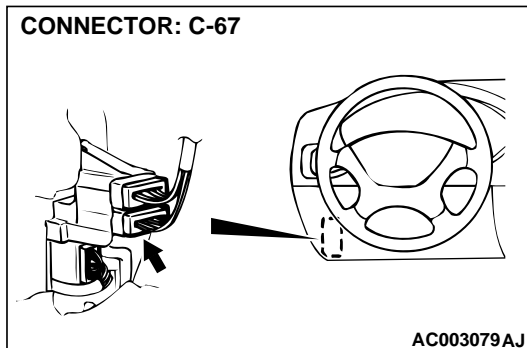

**CIRCUIT OPERATION**

The ETACS-ECU uses the input signal from the trunk lid lock key cylinder switch to arm the theft-alarm

system.

TSB Revision

**TECHNICAL DESCRIPTION (COMMENT)**

The trunk lid lock key cylinder switch input signal is used to arm the theft-alarm system. If the input signal is an error, the theft-alarm system will not be armed normally.

**TROUBLESHOOTING HINTS**

- Malfunction of the trunk lid lock key cylinder switch
- Malfunction of the ETACS-ECU
- Damaged harness wires or connectors

**DIAGNOSIS****Required Special Tools:**

- MB991223: Harness Set
- MB991502: Scan Tool (MUT-II)
- MB991529: Diagnostic Trouble Code Check Harness

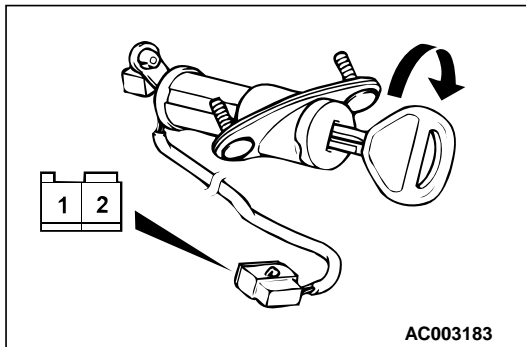
**STEP 1. Check the trunk lid lock key cylinder switch.**

SWITCH POSITION	TESTER CONNECTION	SPECIFIED CONDITION
UNLOCK	1 – 2	Continuity
Neutral (OFF)	–	No continuity

**Q: Is the trunk lid lock key cylinder switch in good condition?**

**YES** : Go to Step 2.

**NO** : Replace it. The input signal from the trunk lid lock key cylinder switch should be able to be checked and the theft-alarm system should be armed normally.

**STEP 2. Check the trunk lid lock key cylinder switch ground circuit at trunk lid lock key cylinder switch connector F-22.**

(1) Disconnect trunk lid lock key cylinder switch connector F-22 and measure at the harness side.

(2) Measure the resistance between terminal 2 and ground.

**Q: Is the resistance less than 2 ohm?**

**YES** : Go to Step 5.

**NO** : Go to Step 3.

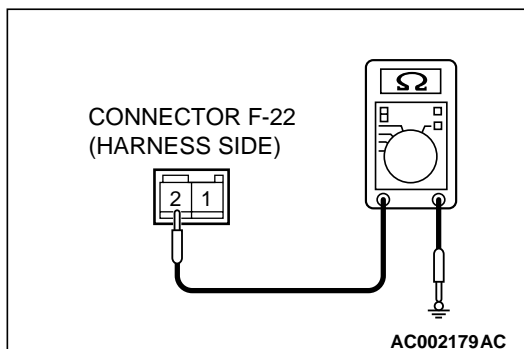

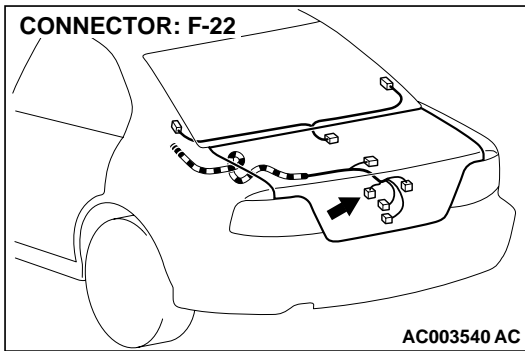

**STEP 3. Check trunk lid lock key cylinder switch connector F-22 for damage.**

**Q: Is trunk lid lock key cylinder switch connector F-22 in good condition?**

**YES :** Go to Step 4.

**NO :** Repair or replace it. Refer to GROUP 00E, Harness Connector Inspection [P.00E-2](#) . The input signal from the trunk lid lock key cylinder switch should be able to be checked and the theft-alarm system should be armed normally.

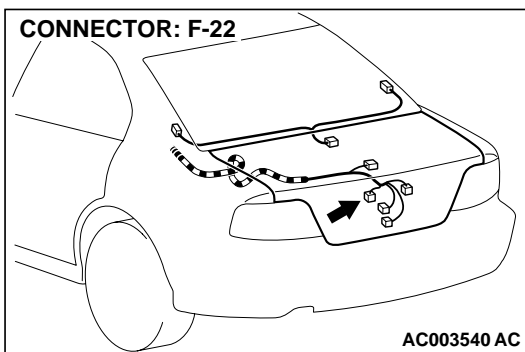

**STEP 4. Check the harness wire between trunk lid lock key cylinder switch connector F-22 and ground.**

**Q: Is the harness wire between trunk lid lock key cylinder switch connector F-22 and ground in good condition?**

**YES :** There is no action to be taken.

**NO :** Repair it. The input signal from the trunk lid lock key cylinder switch should be able to be checked and the theft-alarm system should be armed normally.

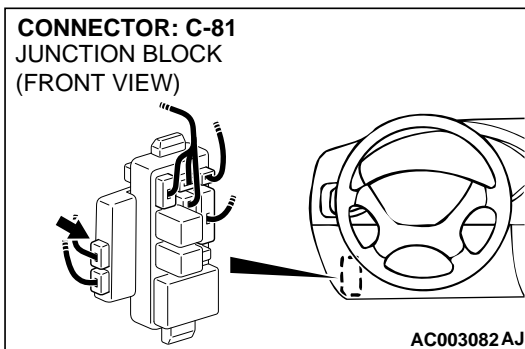

**STEP 5. Check trunk lid lock key cylinder switch connector F-22 and ETACS-ECU connector C-81 for damage.**

**Q: Are trunk lid lock key cylinder switch connector F-22 and ETACS-ECU connector C-81 in good condition?**

**YES :** Go to Step 6.

**NO :** Repair or replace them. Refer to GROUP 00E, Harness Connector Inspection [P.00E-2](#) . The input signal from the trunk lid lock key cylinder switch should be able to be checked and the theft-alarm system should be armed normally.

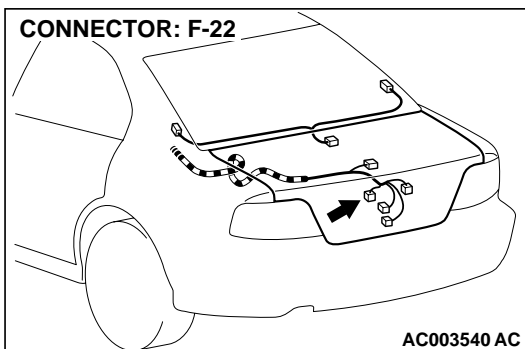

**CONNECTOR: C-81**  
JUNCTION BLOCK  
(FRONT VIEW)

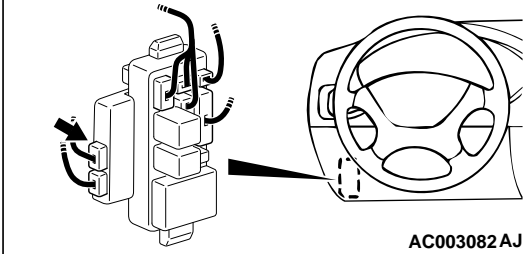

AC003082AJ

**CONNECTOR: F-22**

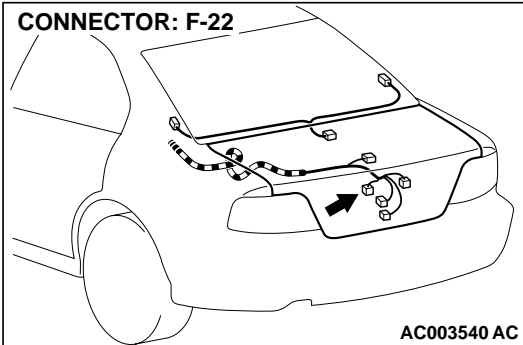

AC003540AC

**CONNECTOR: C-67**

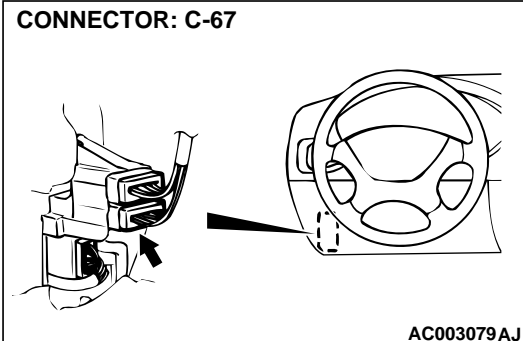

AC003079AJ

**STEP 6. Check the harness wires between trunk lid lock key cylinder switch connector F-22 and ETACS-ECU connector C-81.**

**NOTE:** After checking intermediate connector C-67, check the wires. If intermediate connector C-67 is damaged, repair or replace it. Refer to GROUP 00E, Harness Connector Inspection P.00E-2.

**Q: Are the harness wires between trunk lid lock key cylinder switch connector F-22 and ETACS-ECU connector C-81 in good condition?**

**YES :** Replace the ETACS-ECU. The input signal from the trunk lid lock key cylinder switch should be able to be checked and the theft-alarm system should be armed normally.

**NO :** Repair them. The input signal from the trunk lid lock key cylinder switch should be able to be checked and the theft-alarm system should be armed normally.



**Inspection Procedure N-14: Column switch: The taillight switch, headlight switch, passing light switch, dimmer switch or turn-signal light switch signal is not sent to the ETACS-ECU.**

**Turn-signal Light and Lighting Switch Input Circuit**

COLUMN SWITCH

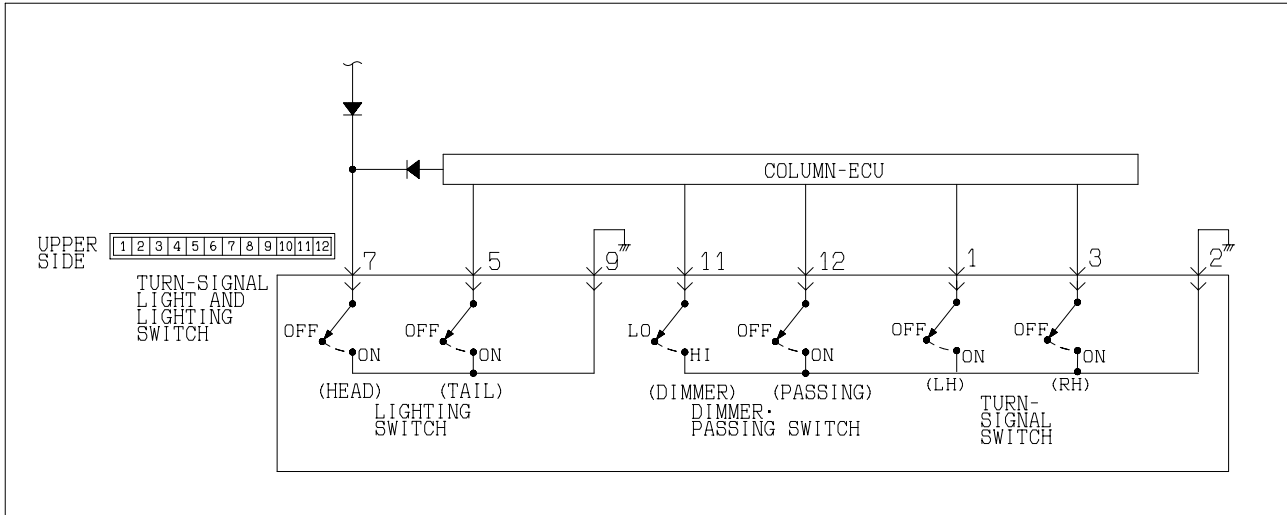

W1809M35AA  
AC004262

**CIRCUIT OPERATION**

The ETACS-ECU uses the input signal from the column switch (turn-signal light and lighting switch) to operate various functions.

- Turn-signal light
  - Fog light
- If the signal fails, these devices will not work normally.

**TECHNICAL DESCRIPTION (COMMENT)**

The column switch (turn-signal light and lighting switch) input signal is used to operate the following devices or functions:

**TROUBLESHOOTING HINTS**

- Light reminder tone alarm function
- Headlight

- Malfunction of the column switch (turn-signal light and lighting switch)
- Malfunction of the ETACS-ECU
- Damaged harness wires or connectors

**DIAGNOSIS**

**Required Special Tools:**

- MB991223: Test Harness Set

**STEP 1. Check the ignition switch positions.**

**Q: Does a diagnostic trouble code set when the ignition switch is at any of the positions?**

**YES :** Carry out the troubleshooting by referring to the Diagnostic Trouble Code Chart. Refer to [P.54B-8](#).

**NO :** Go to Step 2.

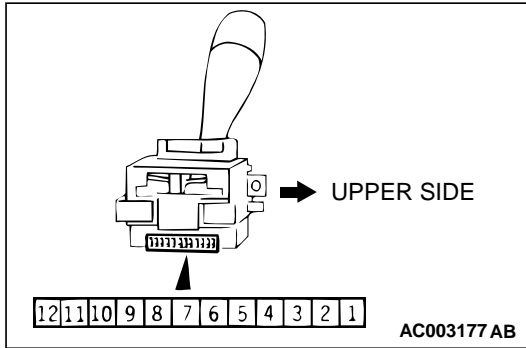
**STEP 2. Check the turn-signal light and lighting switch.**

SWITCH POSITION	TESTER CONNECTION	SPECIFIED CONDITION
OFF	–	No continuity
Taillight switch	5 – 9	Continuity
Headlight switch	5 – 7 – 9	Continuity
Passing switch	2 – 12	Continuity
Dimmer switch	2 – 11 – 12	Continuity
Turn-signal light switch (LH)	1 – 2	Continuity
Turn-signal light switch (RH)	2 – 3	Continuity

**Q: Is the turn-signal light and lighting switch in good condition?****YES** : Go to Step 3.**NO** : Replace it. The input signal from the column switch (turn-signal light and lighting switch) should be able to be checked and the functions, which are described in the "Technical Description (comment)," should work normally.**STEP 3. Replacement of ECU**

- (1) Replace the column switch.
- (2) The input signal from the column switch (turn-signal light and lighting switch) should be able to be checked and the functions, which are described in the "Technical Description (comment)," should work normally.

**Q: Is the input signal from the column switch (turn-signal light and lighting switch) input normally?****YES** : There is no action to be taken.**NO** : Replace the ETACS-ECU. The input signal from the column switch (turn-signal light and lighting switch) should be able to be checked and the functions, which are described in the "Technical Description (comment)," should work normally.

**Inspection Procedure N-15: Column switch: The windshield mist wiper switch, windshield intermittent wiper switch, windshield low-speed wiper switch or windshield high-speed wiper switch or windshield washer switch signal is not sent to the ETACS-ECU.**

**Windshield Wiper and Windshield Washer Switch Input Circuit**

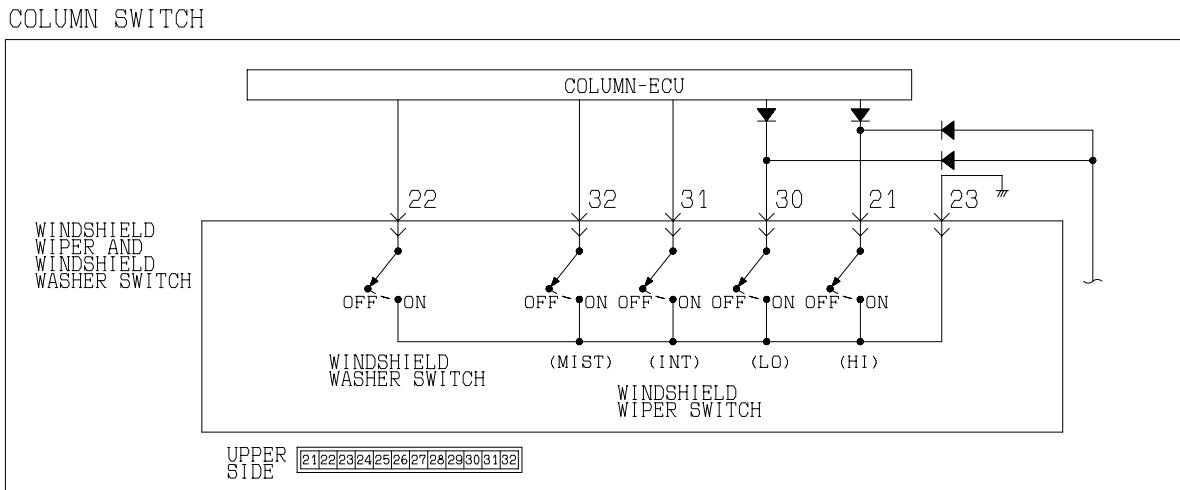

W1S09M36AA  
AC004263

**CIRCUIT OPERATION**

The ETACS-ECU uses the input signal from the column switch (windshield wiper and washer switch) to operate various functions.

**TECHNICAL DESCRIPTION (COMMENT)**

The column switch (windshield wiper and washer switch) input signal is used to operate the windshield wiper and washer. If the signal fails, windshield wiper and washer will not work normally.

**TROUBLESHOOTING HINTS**

- Malfunction of the column switch (windshield wiper and washer switch)
- Malfunction of the ETACS-ECU
- Damaged harness wires or connectors

**DIAGNOSIS**

**Required Special Tools:**

- MB991223: Test Harness Set

**STEP 1. Check the ignition switch positions.**

**Q: Does a diagnostic trouble code set when the ignition switch is at any of the positions?**

**YES :** Carry out the troubleshooting by referring to the Diagnostic Trouble Code Chart. Refer to [P.54B-8](#).

**NO :** Go to Step 2.

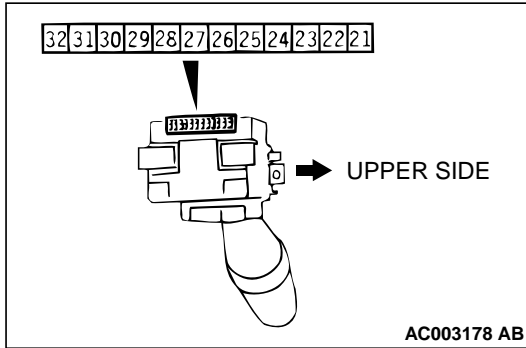
**STEP 2. Check the windshield wiper and washer switch.**

SWITCH POSITION	TESTER CONNECTION	SPECIFIED CONDITION
OFF	–	No continuity
Windshield mist wiper switch	22 – 32	Continuity
Windshield intermittent wiper switch	22 – 31	Continuity
Windshield low-speed wiper switch	22 – 30	Continuity
Windshield high-speed wiper switch	21 – 23	Continuity
Windshield washer switch	22 – 23	Continuity

**Q: Is the windshield wiper and washer switch in good condition?****YES :** Go to Step 3.**NO :** Replace it. The input signal from the column switch (windshield wiper and washer switch) should be able to be checked and the windshield wiper and washer should work normally.**STEP 3. Replacement of ECU**

- (1) Replace the column switch (turn-signal light and lighting switch).
- (2) The input signal from the column switch (windshield wiper and washer switch) should be able to be checked and the windshield wiper and washer should work normally.

**Q: Is the input signal from the column switch (windshield wiper and washer switch) input normally?****YES :** There is no action to be taken.**NO :** Replace the ETACS-ECU. The input signal from the column switch (windshield wiper and washer switch) should be able to be checked and the windshield wiper and washer should work normally.

**Inspection Procedure N-16: The windshield intermittent wiper interval adjusting knob signal is not sent to the ETACS-ECU.**

**Windshield Intermittent Wiper Intervals Adjusting Knob Input Circuit**

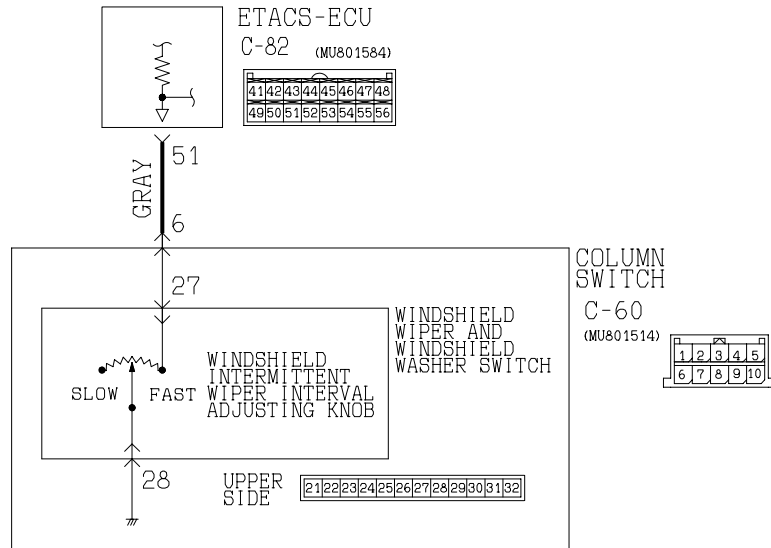

W1S09M37AA  
AC004264

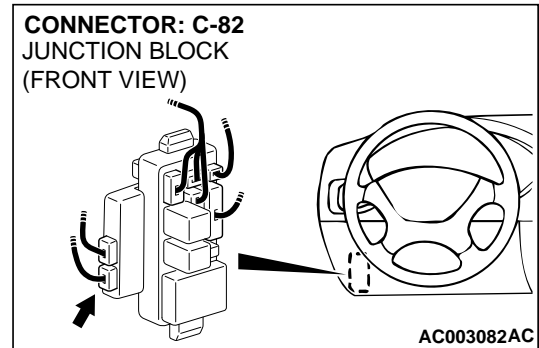
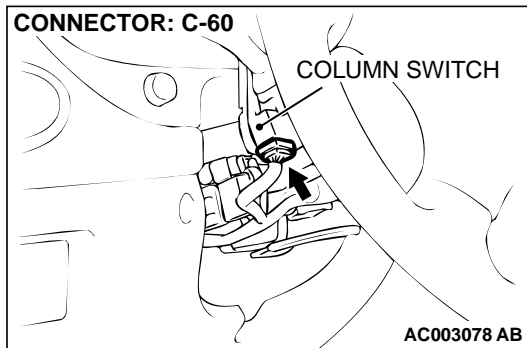

**CIRCUIT OPERATION**

The ETACS-ECU calculates the windshield intermittent wiper interval according to the resistance of the windshield intermittent wiper interval adjusting knob, which is incorporated in the column switch (windshield wiper and windshield washer switch).

**TECHNICAL DESCRIPTION (COMMENT)**

If the windshield intermittent wiper interval adjusting knob is defective, the windshield intermittent wiper interval can not be adjusted.

**TROUBLESHOOTING HINTS**

- Malfunction of the column switch
- Malfunction of the ETACS-ECU
- Damaged harness wires or connectors

**DIAGNOSIS**

**Required Special Tools:**

- MB991223: Test Harness Set

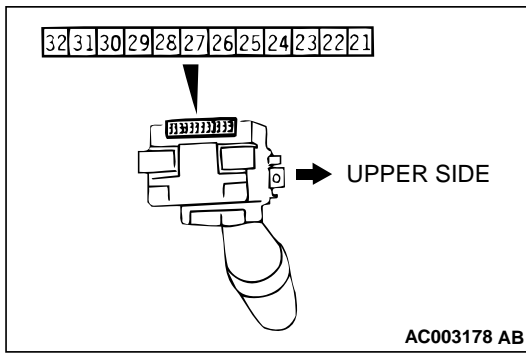
**STEP 1. Check the windshield intermittent wiper interval adjusting knob and column switch body.**

Check the resistance at terminal numbers 27 and 28. The resistance should change smoothly from approximately  $0\ \Omega$  ("FAST" position) to approximately  $1\ \text{k}\Omega$  ("SLOW" position).

**Q: Is the windshield intermittent wiper interval adjusting knob in good condition?**

**YES** : Go to Step 2.

**NO** : Replace the it. Check that the input signal from the windshield intermittent wiper interval adjusting knob can be checked and the wiper interval can be adjusted.

**STEP 2. Check column switch connector C-60 and ETACS-ECU connector C-82 for damage.****Q: Is column switch connector C-60 and ETACS-ECU connector C-82 in good condition?**

**YES** : Go to Step 3.

**NO** : Repair or replace them. Refer to GROUP 00E, Harness Connector Inspection [P.00E-2](#) . Check that the input signal from the windshield intermittent wiper interval adjusting knob can be checked and the wiper interval can be adjusted.

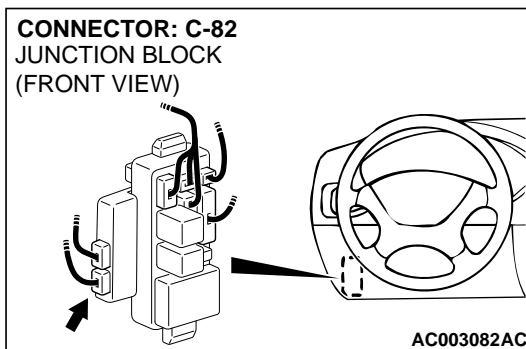
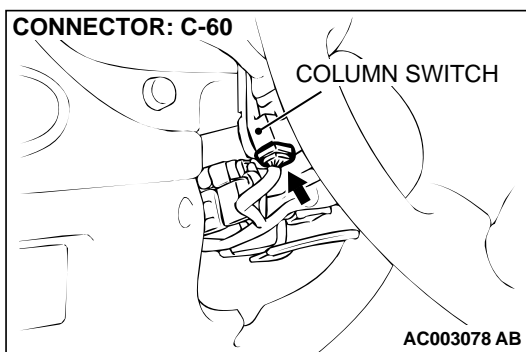

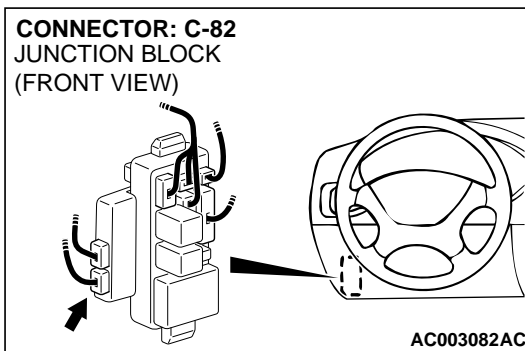
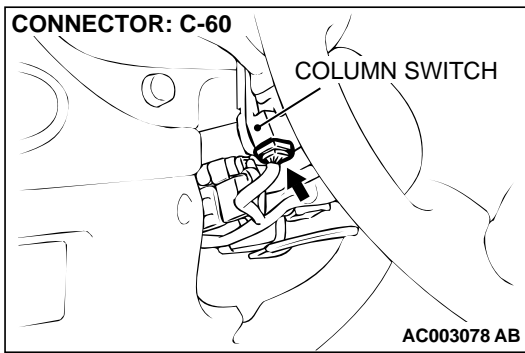

**STEP 3. Check the harness wire between column switch connector C-60 and ETACS-ECU connector C-82.**

**Q: Is the harness wire between column switch connector C-60 and ETACS-ECU connector C-82 in good condition?**

**YES :** Go to 4.

**NO :** Repair it. Check that the input signal from the windshield intermittent wiper interval adjusting knob can be checked and the wiper interval can be adjusted.

**STEP 4. Replacement of ECU**

- (1) Replace the ETACS-ECU.
- (2) Check that the input signal from the windshield intermittent wiper interval adjusting knob can be checked and the wiper interval can be adjusted.

**Q: Is the input signal from the windshield intermittent wiper interval adjusting knob input normally?**

**YES :** There is no action to be taken.

**NO :** Replace the column switch. Check that the input signal from the windshield intermittent wiper interval adjusting knob can be checked and the wiper interval can be adjusted.

**Inspection Procedure N-17: Transmitter: The lock, unlock, trunk or panic switch signal is not sent to the ETACS-ECU.**

**Receiver and Transmitter Communication System**

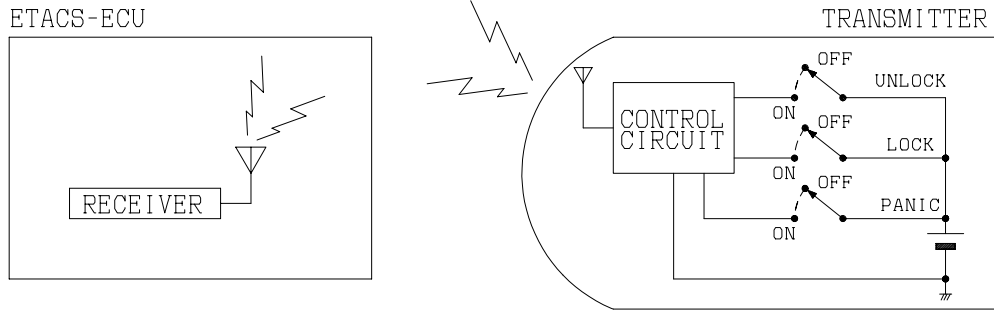

W9S02M05A  
AC004205

**CIRCUIT OPERATION**

The ETACS-ECU receives an input signal from the transmitter through its built-in receiver, and evaluates the signal to operate various functions.

**TECHNICAL DESCRIPTION (COMMENT)**

The transmitter input signal is used to operate the following systems:

- Keyless entry system

- Theft-alarm system <vehicles with theft-alarm system>
- If the signal fails, these systems will not work normally.

**TROUBLESHOOTING HINTS**

- Malfunction of the transmitter
- Malfunction of the ETACS-ECU

**STEP 1. Register the transmitter.**

Register the transmitter (Refer to GROUP 42, Keyless Entry System – On-vehicle Service – How To Secret Registration Method [P.42-70](#).)

**Q: Is the transmitter registered successfully?**

**YES :** The transmitter input signal should be able to be checked and the functions, which are described in the "Technical Description (comment)," should work normally.

**NO :** Go to Step 2.

**STEP 2. Check the transmitter battery.**

Measure the transmitter battery's voltage.

**Q: Is the voltage approximately 2.5 – 3.2 volts?**

**YES :** Go to Step 3.

**NO :** Replace the battery. If the transmitter is registered successfully, the transmitter input signal should be able to be checked and the functions, which are described in the "Technical Description (comment)," should work normally.

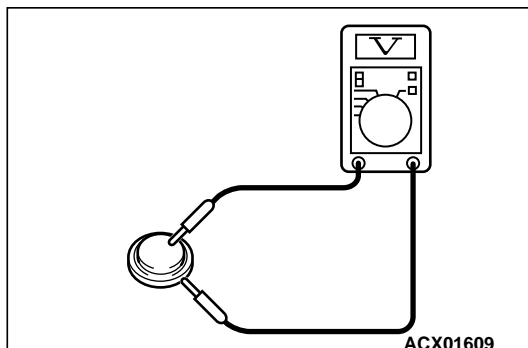



**STEP 3. Check the transmitter.**

(1) Use an other transmitter to register the secret code. (Refer to GROUP 42, Keyless Entry System – On-vehicle Service – How To Secret Registration Method P.42-70 .)

**Q: Is the transmitter registered successfully?**

**YES :** The transmitter input signal should be able to be checked and the functions, which are described in the "Technical Description (comment)," should work normally.

**NO :** Replace the ETACS-ECU. The transmitter input signal should be able to be checked and the functions, which are described in the "Technical Description (comment)," should work normally.

**Inspection Procedure O-1: Check the circuit (power supply line) from the battery to the ETACS-ECU.**

**CHECK THE CIRCUIT (POWER SUPPLY LINE) FROM BATTERY**

- Refer to Inspection Procedure A-1 (P.54B-31).

**CIRCUIT OPERATION**

The ETACS-ECU is always energized by the battery.

**TECHNICAL DESCRIPTION (COMMENT)**

If that power supply circuit is defective, the circuit flowing through the ignition switch (IG1) will function as a backup circuit. In this case, the following functions will not work when the ignition switch is at "LOCK" (OFF) position:

- Ignition key reminder tone alarm function

- Light reminder tone alarm function
- Central door locking system
- Hazard warning light
- Dome light dimming function
- Theft-alarm system <vehicles with theft-alarm system>

**TROUBLESHOOTING HINTS**

- Malfunction of the ETACS-ECU
- Damaged harness wires or connectors

**DIAGNOSIS**

**Required Special Tools:**

- MB991223: Test Harness Set
- MB991502: Scan Tool (MUT-II)
- MB991529: Diagnostic Trouble Code Check Harness

**STEP 1. Check the battery circuit at the ETACS-ECU connector C-86.**

(1) Disconnect the ETACS-ECU connector C-86 and measure at the junction block side.

(2) Measure the Voltage between terminal 2 and ground.

**Q: Is the voltage approximately 12 volts (battery positive voltage)?**

**YES :** Replace the ETACS-ECU. The functions, which are described in the "Technical Description (comment)," should work normally.

**NO :** Go to Step 2.

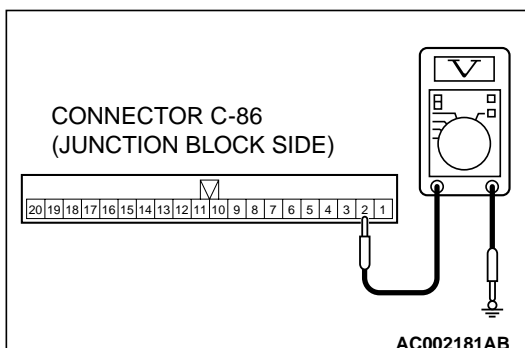

**CONNECTOR: C-86**  
JUNCTION BLOCK  
(REAR VIEW)

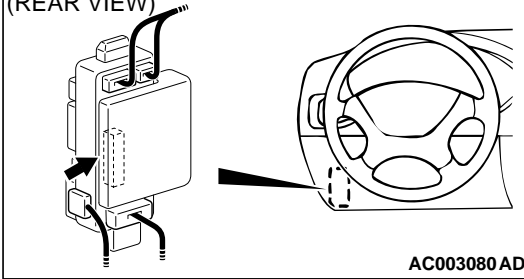

**STEP 2. Check ETACS-ECU connector C-86 for damage.**

**Q: Is ETACS-ECU connector C-86 in good condition?**

**YES :** Go to Step 3.

**NO :** Repair or replace it. Refer to GROUP 00E, Harness Connector Inspection [P.00E-2](#) . The functions, which are described in the "Technical Description (comment)," should work normally.

**CONNECTOR: C-86**  
JUNCTION BLOCK  
(REAR VIEW)

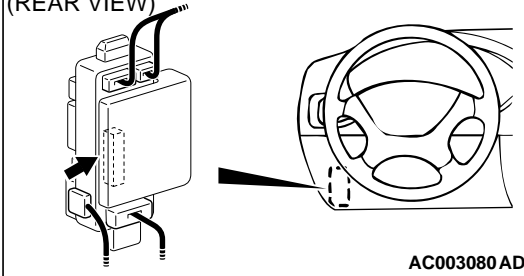

**STEP 3. Check the harness wires between ETACS-ECU connector C-86 and battery.**

**NOTE:** After checking junction block connector C-84 and intermediate connector C-66, check the wires. If junction block connector C-84 and intermediate connector C-66 are damaged, repair or replace them. Refer to GROUP 00E, Harness Connector Inspection [P.00E-2](#).

**Q: Are the harness wires between ETACS-ECU connector C-86 and battery in good condition?**

**YES :** There is no action to be taken.

**NO :** Repair them. The functions, which are described in the "Technical Description (comment)," should work normally.

**CONNECTOR: C-66**  
CONNECTOR  
BLOCK (LH)

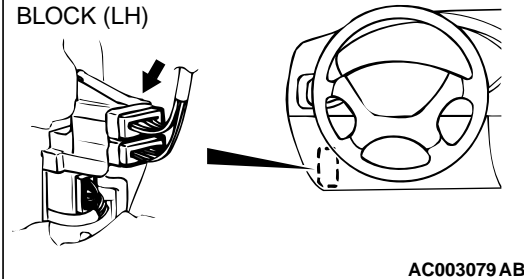

**CONNECTOR: C-84**  
JUNCTION BLOCK  
(REAR VIEW)

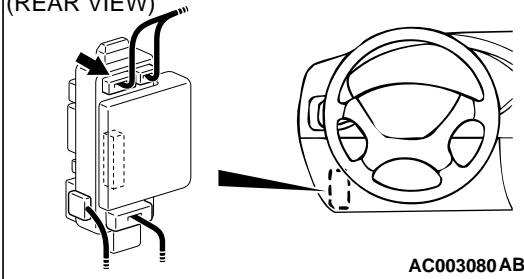

**SPECIAL TOOLS**

M1549000300065

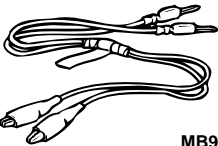
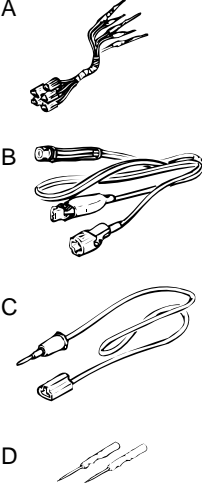
TOOL	TOOL NUMBER AND NAME	REPLACED BY MILLER TOOL NUMBER	APPLICATION
 <p>B991502</p>	<p>MB991502 Scan tool (MUT-II)</p>	<p>DRB-III scan tool</p>	<p>Checking the diagnostic trouble code and input signal</p>
 <p>MB991529</p>	<p>MB991529 Diagnostic trouble code check harness</p>	<p>MB991529</p>	<p>Checking input signal when using a voltmeter</p>
 <p>MB991223AD</p>	<p>MB991223 A:MB991219 B:MB991220 C:MB991221 D:MB991222 Harness set A:Test harness B:LED harness C:LED harness adaptor D:Probe</p>	<p>MB991223</p>	<p>Making voltage and resistance measurement during trouble-shooting A:Connector pin contact pressure inspection B:Power circuit inspection C:Power circuit inspection D:Commercial tester connection</p>



---

## NOTES