

GROUP 90

CIRCUIT DIAGRAMS

CONTENTS

HOW TO READ CIRCUIT DIAGRAMS	90-4	90-76
JUNCTION BLOCK	90-10	VANITY MIRROR LIGHT	90-78
JOINT CONNECTOR.....	90-12	TURN-SIGNAL LIGHT AND HAZARD WARNING LIGHT.....	90-80
CENTRALIZED JUNCTION.....	90-13	STOPLIGHT	90-84
POWER DISTRIBUTION SYSTEM ..	90-20	BACKUP LIGHT	90-86
STARTING SYSTEM	90-25	HORN	90-87
IGNITION SYSTEM <2.4L ENGINE>.	90-26	METER AND GAUGE.....	90-88
IGNITION SYSTEM <3.0L ENGINE>.	90-27	BRAKE WARNING LIGHT, OIL PRESSURE WARNING LIGHT, FUEL WARNING LIGHT	90-90
CHARGING SYSTEM	90-28	POWER WINDOWS	90-92
MFI SYSTEM <2.4L ENGINE>.....	90-30	CENTRAL DOOR LOCKING SYSTEM	90-96
MFI SYSTEM <3.0L ENGINE>.....	90-40	HEATER	90-106
COOLING SYSTEM	90-50	AIR CONDITIONING SYSTEM <2.4L ENGINE>	90-110
INVECS-II 4A/T	90-52	AIR CONDITIONING SYSTEM <3.0L ENGINE>	90-116
HEADLIGHT.....	90-60	WINDSHIELD WIPER AND WASHER	90-124
TAIL LIGHT, POSITION LIGHT AND LICENSE PLATE LIGHT	90-64	DEFOGGER AND DOOR MIRROR HEATER	90-128
FOG LIGHT	90-68		
DOME LIGHT AND TRUNK LIGHT..	90-72		
IGNITION KEY HOLE ILLUMINATION LIGHT			

REMOTE CONTROLLED MIRROR.	90-131	<VEHICLES WITHOUT TCL>.	90-152
RADIO AND TAPE PLAYER <4-SPEAKER SYSTEM>.	90-132	ANTI-LOCK BRAKING SYSTEM (ABS) <VEHICLES WITH TCL>	90-156
RADIO AND TAPE PLAYER <7-SPEAKER SYSTEM>.	90-134	SUPPLEMENTAL RESTRAINT SYSTEM (SRS) <VEHICLES WITHOUT SIDE AIR BAG>	90-160
CIGARETTE LIGHTER	90-138	SUPPLEMENTAL RESTRAINT SYSTEM (SRS) <VEHICLES WITH SIDE AIR BAG>..	90-162
ACCESSORY SOCKET.	90-139	POWER SEAT	90-164
SUNROOF	90-140	THEFT-ALARM SYSTEM.	90-166
LIGHTING MONITOR TONE ALARM	90-142	FORGOTTEN KEY PREVENTION FUNCTION	90-174
KEY REMINDER TONE ALARM.	90-144	RHEOSTAT.	90-177
SEAT BELT TONE ALARM.	90-146	IMMOBILIZER SYSTEM.	90-178
AUTO-CRUISE CONTROL SYSTEM	90-148		
ANTI-LOCK BRAKING SYSTEM (ABS)			

NOTES

TSB Revision

HOW TO READ CIRCUIT DIAGRAMS

M1901000100083

The circuit of each system from the fuse (or fusible link) to ground is shown. The power supply is shown at the top and the ground at the bottom to facilitate understanding of how the current flows.

Indicates power source.

Indicates that terminal is connected via a plate in the relay box.

Each circuit diagram consists of block(s). The blocks are divided by page number.

Indicates splice point numbers. These numbers are identical to those described in "Splice Locations."

Indicates the circuit name to be connected. The arrow indicates the current flow direction.

Indicates the power supply in the control unit. If no voltage is displayed, this indicates battery positive voltage.

An "X" at the end of a connector number indicates that the connector is connected to a centralized junction that is shown in the section "Centralized Junction."

Indicates that the diagram continues at ▽ which belongs to the [2] block in the same circuit.

Indicates the connector symbol. Connectors in the circuit diagram are indicated in numerical order.

Indicates connector number. The same number as used in the wiring harness diagram. Connector and connector numbers are shown at the lower part of the page. Connector numbers not enclosed by frame indicate the device incorporated into wiring harness.

Indicates the circuit name to be connected. The arrow indicates the current flow direction.

Indicates the operating conditions of the engine coolant switch, etc.

Indicates shield wire.

Indicates that current flows upwards.

TSB Revision

ACX02361AB

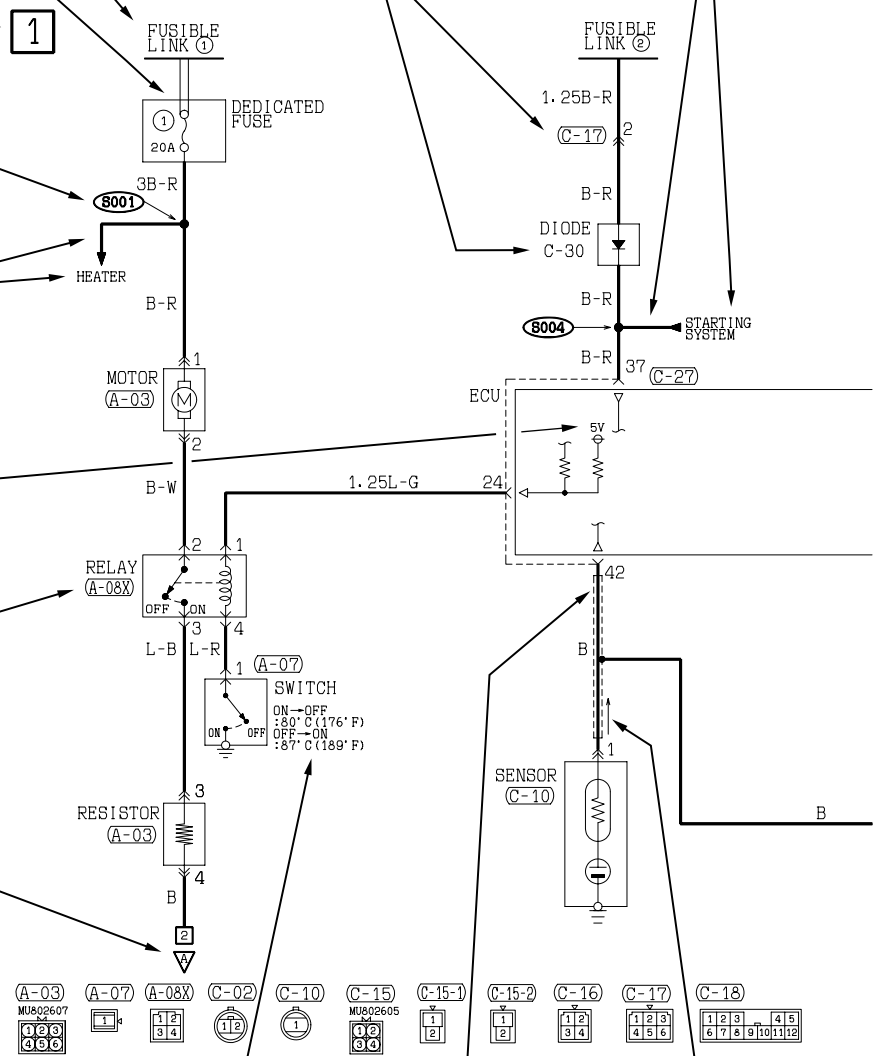

- (A-03) MU&C2607
1 2 3
4 5 6
- (A-07) [Symbol]
1 2
- (A-08X) 1 2
3 4
- (C-02) 1 2
- (C-10) 1
- (C-15) MU&C2605
1 2
3 0
- (C-15-1) 1
2
- (C-15-2) 1
2
- (C-16) 1 2
3 4
- (C-17) 1 2 3
4 5 6
- (C-18) 1 2 3 4 5
6 7 8 9 10 11 12

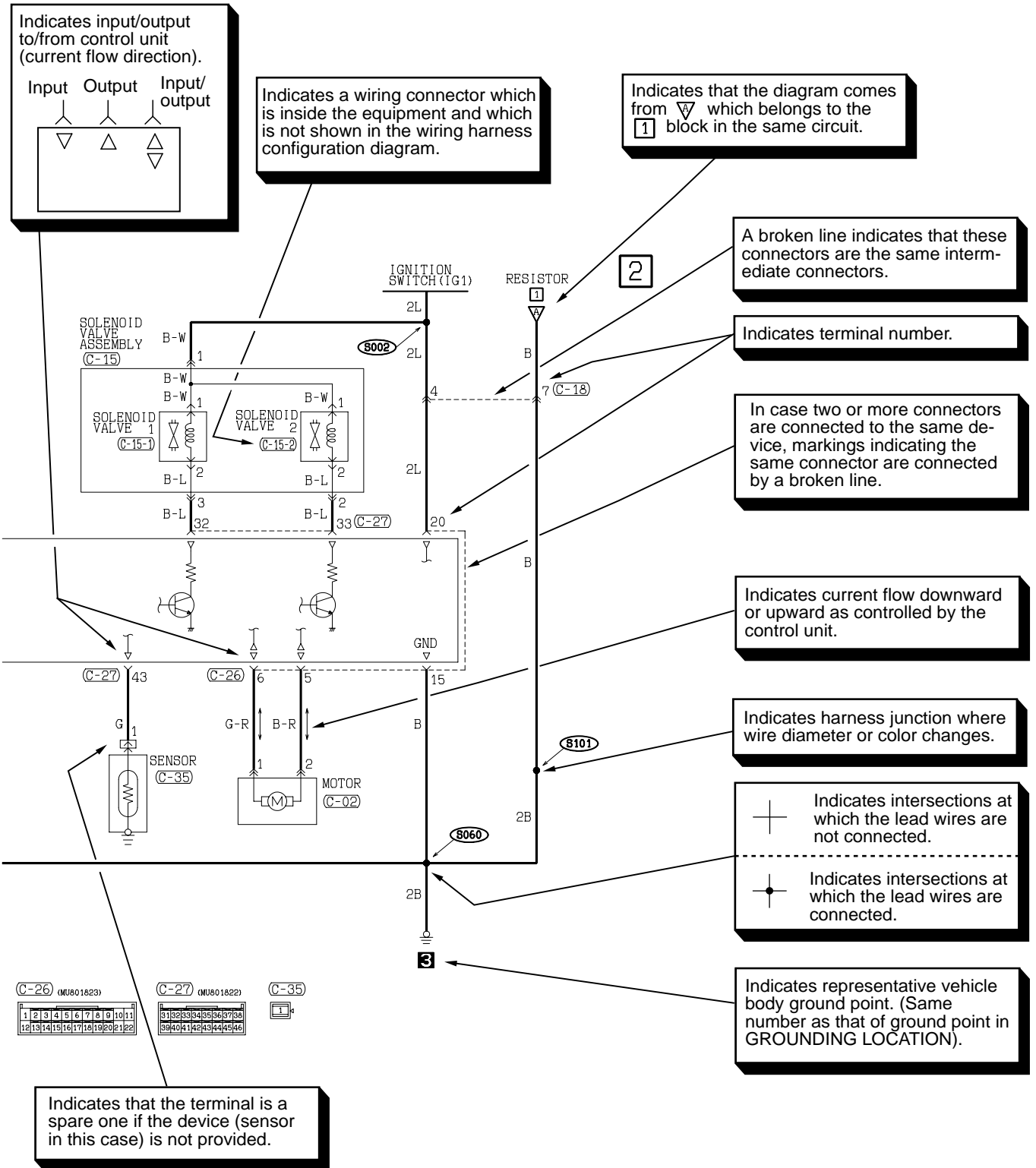



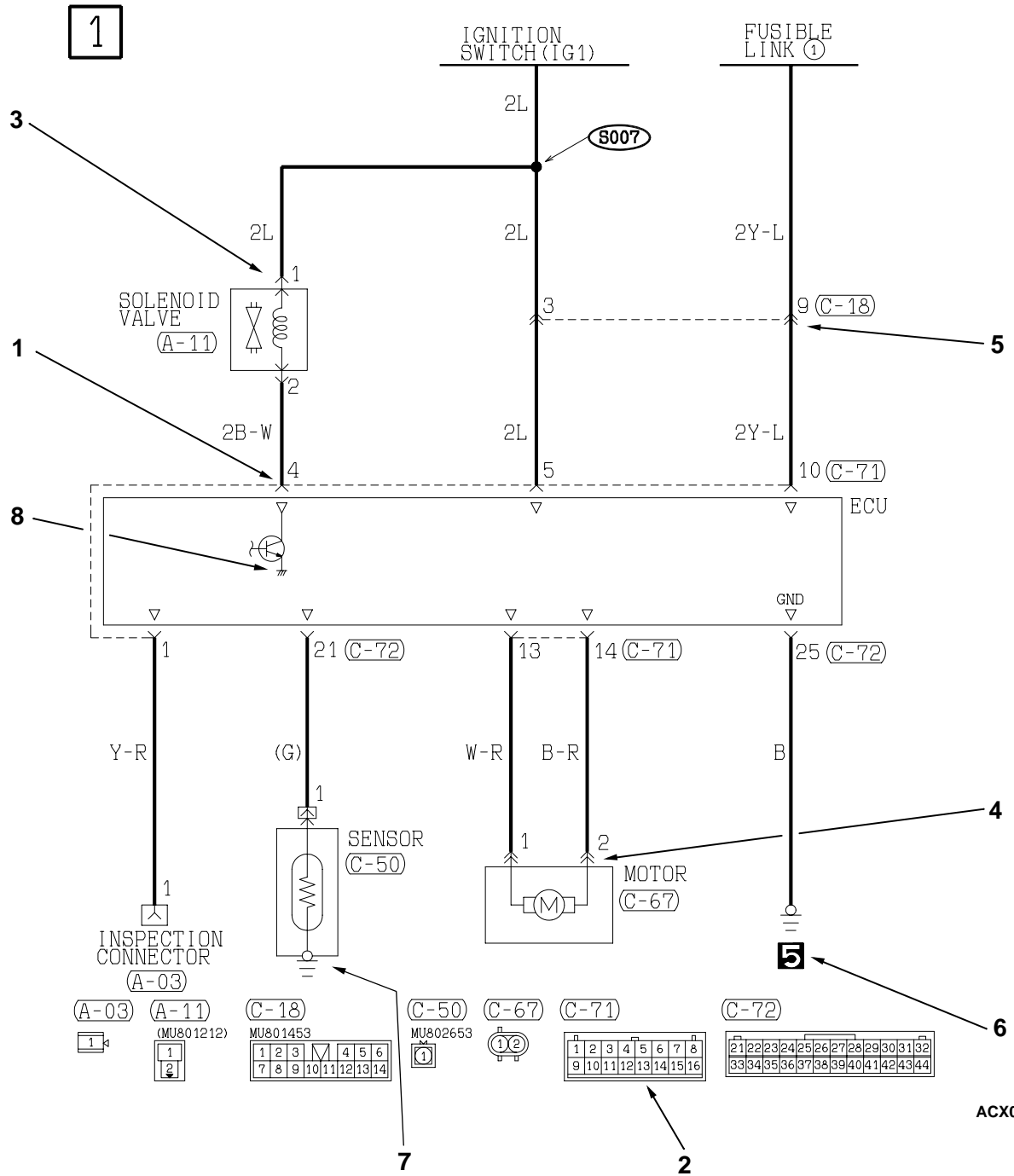





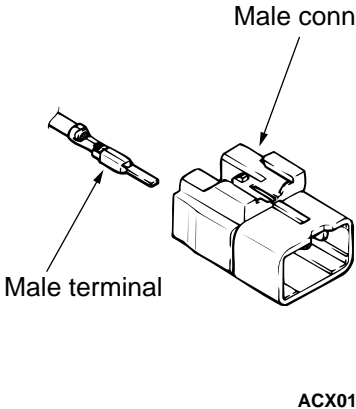

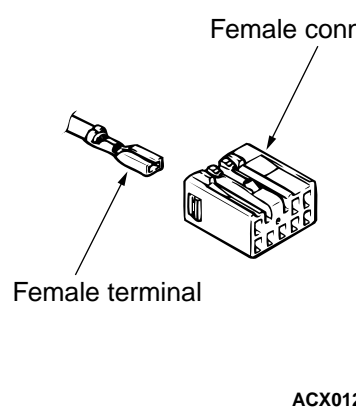
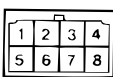
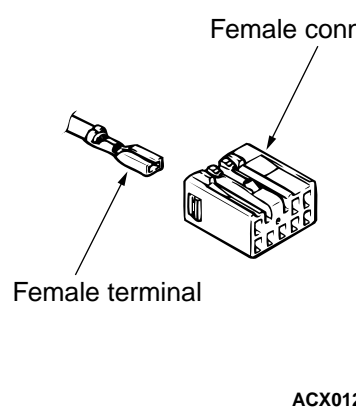

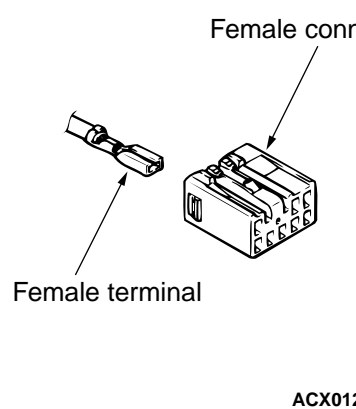
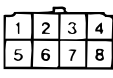
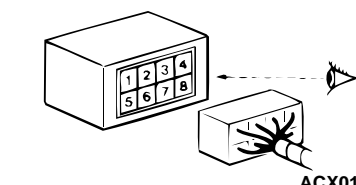
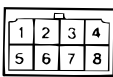
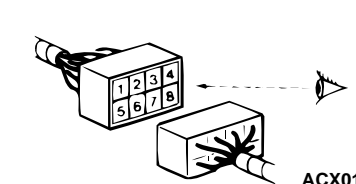

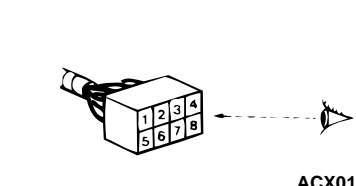
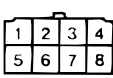

CONNECTOR/GROUNDING INDICATIONS

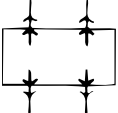
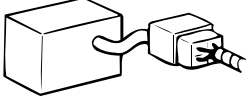
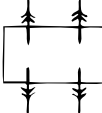

ACX02364AB





















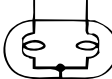

TSB Revision

ITEM	NO.	CONNECTOR/ GROUNDING	SYMBOL	CONTENTS
Connector and terminal marking	1		<p>Male terminal</p>  <p>ACX01252AB</p>	The male and female terminals are indicated as shown. The connector with male terminal(s) is called as male connector and indicated by two connector contour lines, while the connector with female terminal(s) is called as female connector and indicated by single connector contour line.
			<p>Male connector</p>  <p>ACX01253AB</p>	
			<p>Female terminal</p>  <p>ACX01255AB</p>	
			<p>Female connector</p>  <p>ACX01256 AB</p>	
Connector symbol marking	2	<p>Device</p> 	 <p>ACX01253</p>	The symbol indicates the connector is viewed as shown. At a device connection, the connector symbol on the device side is shown. For an intermediate connector, the male connector symbol is shown. For spare connectors and check connectors, no device is connected, and so the harness-side connector symbol is shown for these connectors. For the data link connector, its contents differ from the previous description. Refer to "scan tool operation instruction" in detail.
		<p>Intermediate connector</p> 		
		<p>Spare connector, check connector</p> 	 <p>ACX01256</p>	

ITEM	NO.	CONNECTOR/ GROUNDING	SYMBOL	CONTENTS
Connector connection marking	3	Direct connection type  ACX01260AB	 ACX01261	Connection between a device and the harness is either by direct insertion in the device (direct connection type) or by connection with a harness connector furnished on the device side furnished (harness connection type). The two types are indicated as illustrated.
	4	Harness connection type  ACX01262AB	 ACX01263	
	5	Intermediate connector  ACX01264AB	 ACX01265	
Ground markings	6	Body ground  ACX01273AB	 ACX01274	Grounding is either by body ground, device ground or control unit interior ground. These are indicated as illustrated.
	7	Device ground  ACX01275AB	 ACX01276	
	8	Ground in control unit  ACX01277AB	 ACX01278	

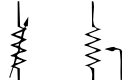
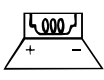
SYMBOLS (EXCEPT CONNECTOR AND GROUNDING)

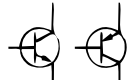
Devices appearing in circuit diagrams are indicated by the following symbols.

battery  ACX02377AB	buzzer  ACX02378AB	Capacitor  ACX02379AB	electrolytic capacitor  ACX02380AB	Variable capacitor  ACX02381AB	Coil  ACX02382AB
diode  ACX02383AB	light emitting diode  ACX02384AB	photo diode  ACX02385AB	Zener diode  ACX02386AB	dual bulb  ACX02387AB	Single bulb  ACX02388AB
Fuse  ACX02389AB	Fusible link  ACX02390AB	horn  ACX02391AB	motor  ACX02392AB	Pulse generator  ACX02393AB	Piezoelectric device  ACX02394AB
Resistor  ACX02395AB	Variable resistor  ACX02396AB	Speaker  ACX02397AB	Thermistor  ACX02398AB	Transistor  ACX02399AB	photo transistor  ACX02400AB

WIRE COLOR CODES

Wire color are identified by the following color codes.

CODE	WIRE COLOR	CODE	WIRE COLOR	CODE	WIRE COLOR	CODE	WIRE COLOR
B	Black	L	Blue	R	Red	Y	Yellow
BR	Brown	LG	Light green	SB	Sky blue	-	-
G	Green	O	Orange	V	Violet	-	-
GR	Gray	P	Pink	W	White	-	-

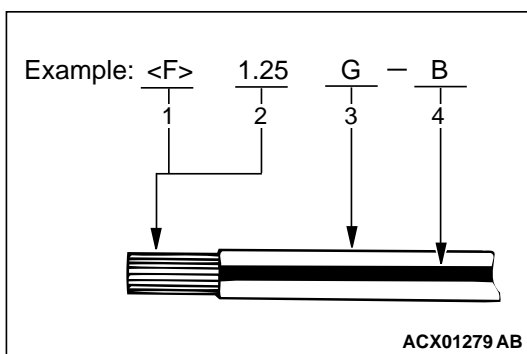

If a cable has two colors, the first of the two color code characters indicates the basic color (color of the cable coating) and the second indicates the marking color.

NO.	MEANING
1	<F>: Flexible wire <T>: Twisted wire
2	Wire size (mm ²)*
3	Basic color (color of the cable coating)
4	Marking color

NOTE:

*: No code indicates 0.5 mm²(0.0008 in²). Cable color code in parentheses indicates 0.3 mm² (0.0005 in²).

JUNCTION BLOCK

M1901000200057

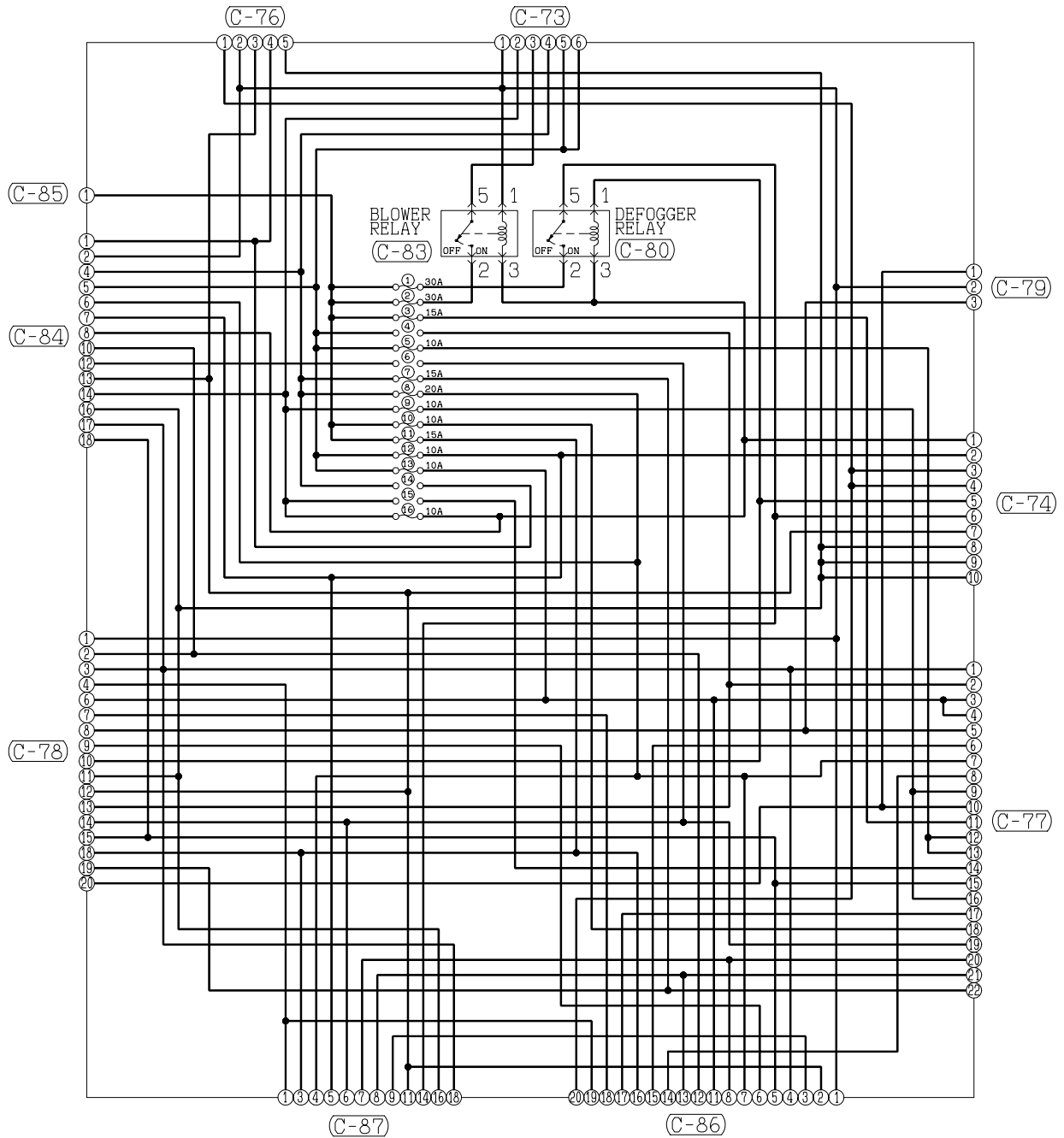

NOTE
CONNECTOR NUMBERS ARE KEYED TO THE CONFIGURATION
DIAGRAM (DASH PANEL) AND EACH CIRCUIT DIAGRAM.

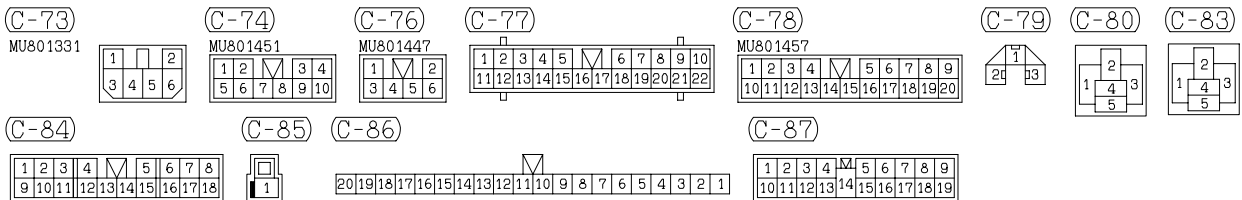

H1500M02AA

TSB Revision

FRONT SIDE

REAR SIDE

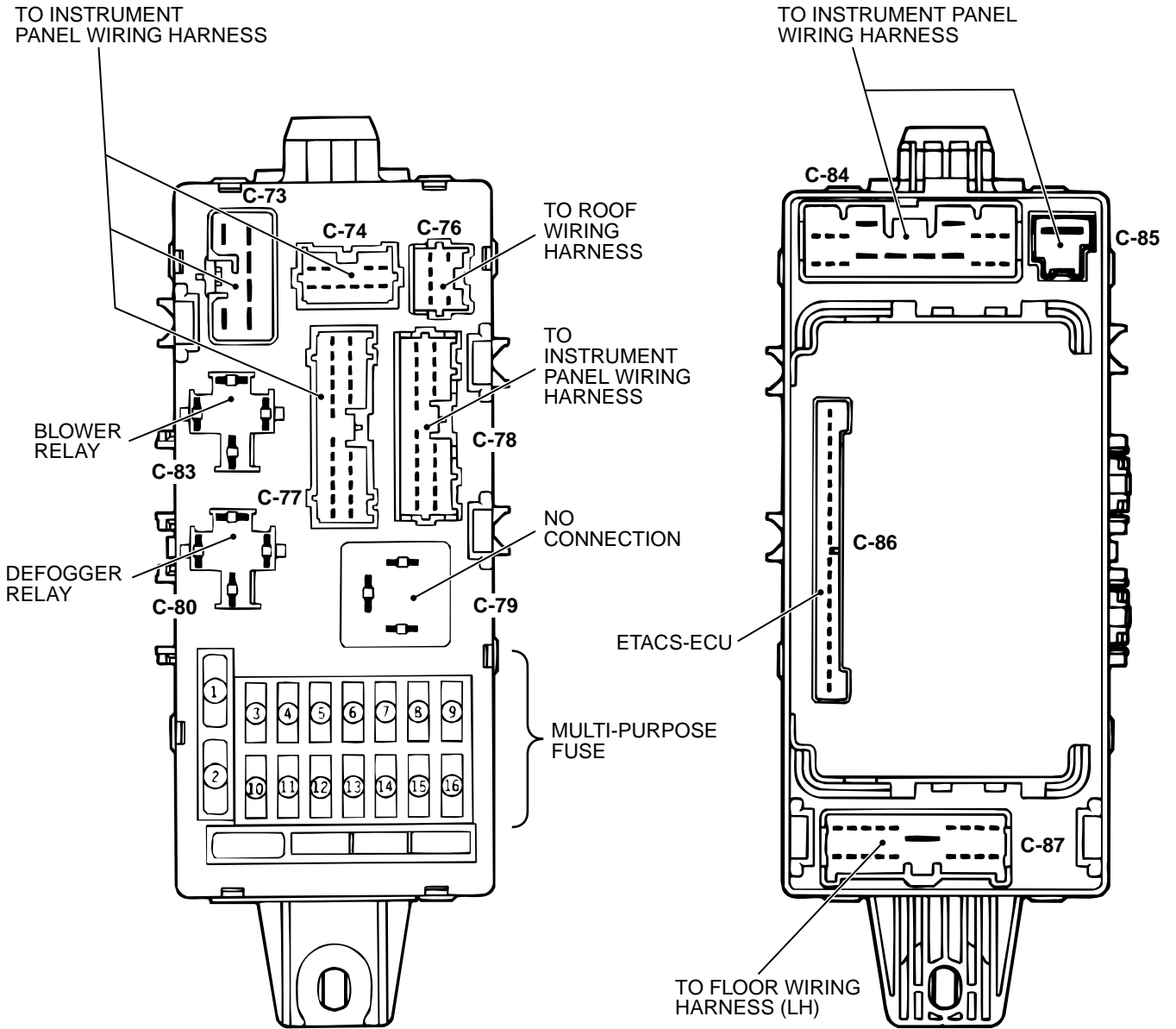

AC000313AC

TSB Revision

JOINT CONNECTOR

M1901014200050

NOTE
IN THE ACTUAL VEHICLE, SOME OF THE JOINT CONNECTOR TERMINALS IN THE SAME BUS ARE USED, SO IN SOME CASES, THE TERMINALS INDICATED ON THE CIRCUIT DIAGRAMS DO NOT AGREE WITH THE ONES IN THE ACTUAL VEHICLE.

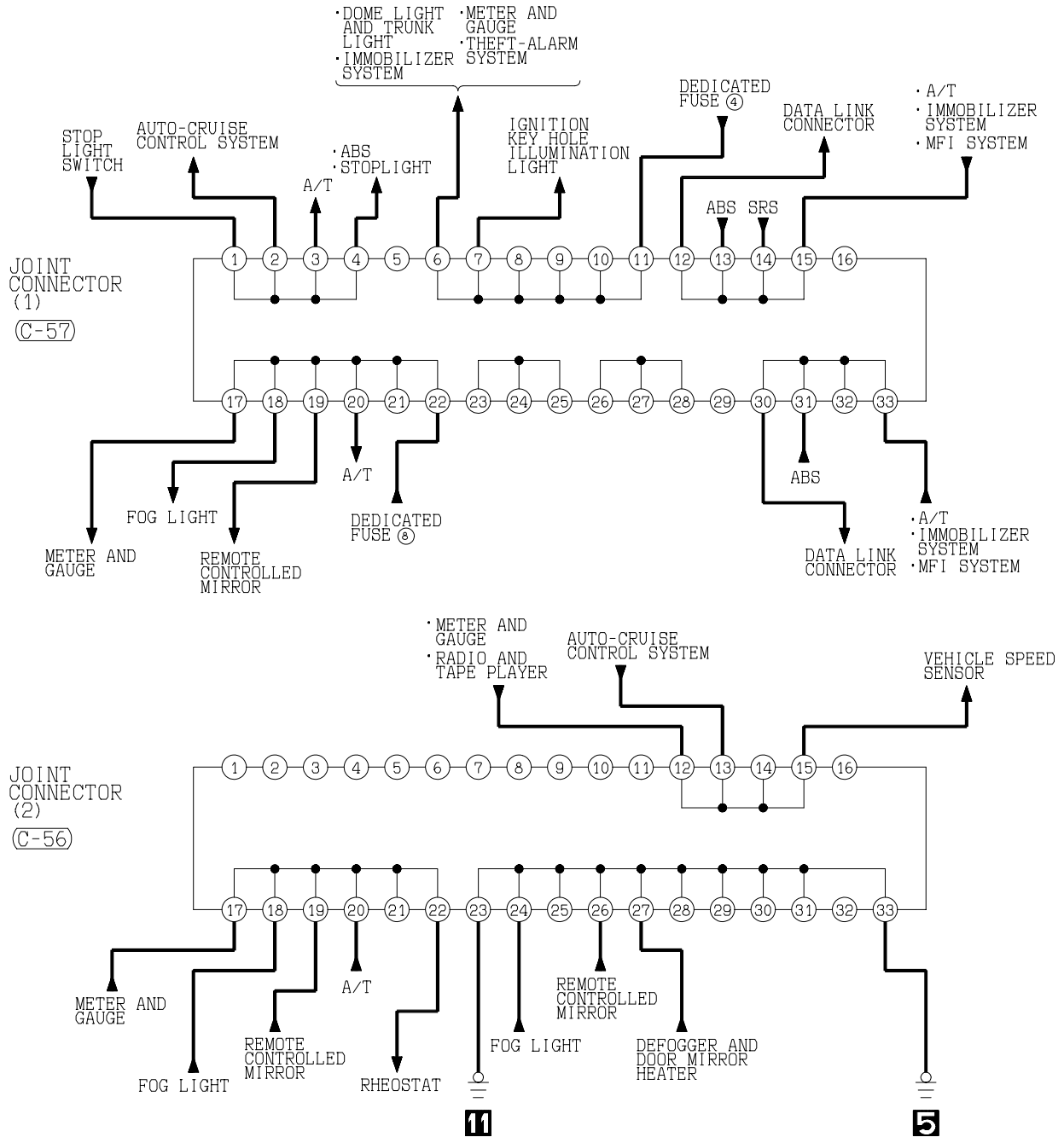

(C-56)

(C-57)

1	2	3	4	5	6	7	8	9	10	11
12	13	14	15	16	17	18	19	20	21	22
23	24	25	26	27	28	29	30	31	32	33

1	2	3	4	5	6	7	8	9	10	11
12	13	14	15	16	17	18	19	20	21	22
23	24	25	26	27	28	29	30	31	32	33

H1500M03AA

CENTRALIZED JUNCTION

M1901000300087

FUSIBLE LINK

NO.	CIRCUIT	HOUSING COLOR	RATED CAPACITY (A)
1	Multi-purpose fuse No.1, 2, 3, 10, 11	Yellow	60
2	–	–	–
3	Dedicated fuse No.15, 17, power windows and power seat	Pink	30
4	Air conditioning system and cooling system	Red	50
5	Anti-lock braking system	Red	50
6	–	–	–
7	Ignition switch circuit	Pink	30
8	Generator circuit	White	120

(RELAY BOX IN ENGINE COMPARTMENT)

FUSIBLE LINKS 1 TO 7

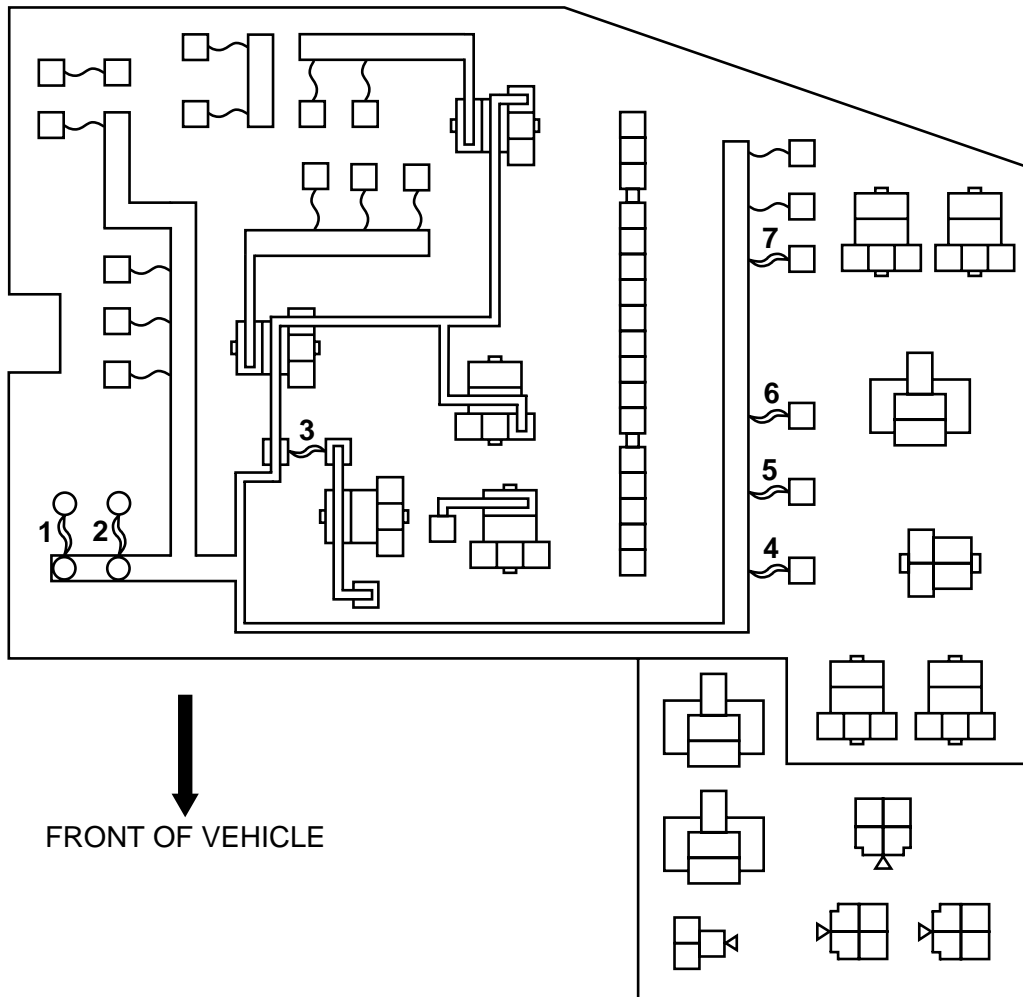

AC000312AD

TSB Revision

(CONNECTED DIRECTLY TO BATTERY POSITIVE TERMINAL)

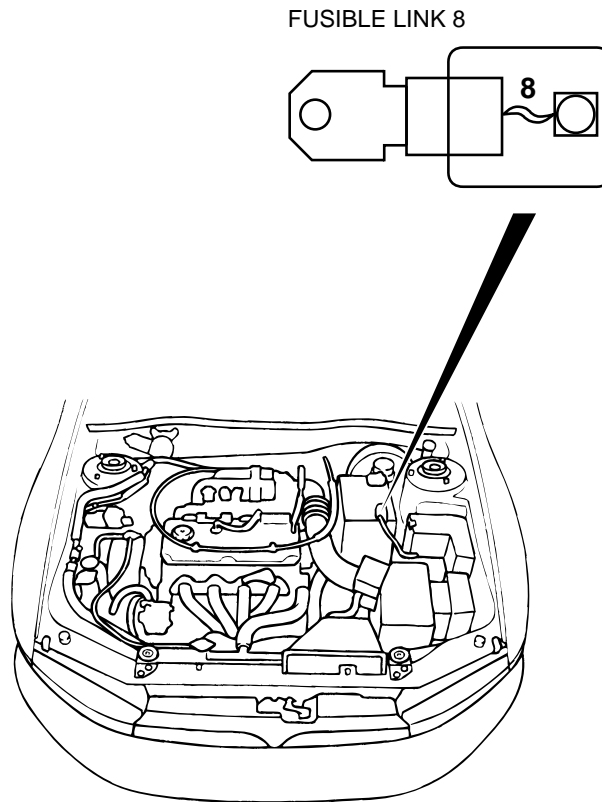

AC002480AB

DEDICATED FUSE

POWER SUPPLY CIRCUIT	NO.	RATED CAPACITY (A)	HOUSING COLOR	CIRCUIT
Battery	1	–	–	–
	2	15	Blue	Fog light
	3	10	Red	Air conditioning system
	4	10	Red	ECU power supply, dome light, trunk light, ignition key hole illumination light, meter, gauge, MFI system and vanity mirror light
Ignition switch (ACC)	5	10	Red	Radio and tape player
Headlight (High)	6	10	Red	Headlight and theft-alarm system
	7	10	Red	Headlight and theft-alarm system
Taillight relay	8	10	Red	Rheostat, taillight, position light and illumination light
	9	10	Red	Taillight, position light and license plate light
	10	–	–	–

TSB Revision

POWER SUPPLY CIRCUIT	NO.	RATED CAPACITY (A)	HOUSING COLOR	CIRCUIT
Headlight relay (Low)	11	10	Red	Headlight
	12	10	Red	Headlight
Battery	13	20	Yellow	INVECS-II 4A/T, MFI system, air conditioning system, cooling system and immobilizer system
	14	10	Red	Charging system, central door locking system, turn-signal light and hazard warning light
Fusible link No.3	15	20	Yellow	Radio and tape player <7-speakers>
–	16	–	–	–
Fusible link No.3	17	20	Yellow	Sunroof
Defogger relay	18	10	Red	Door mirror heater

(RELAY BOX IN ENGINE COMPARTMENT)

DEDICATED FUSES 1 TO 14

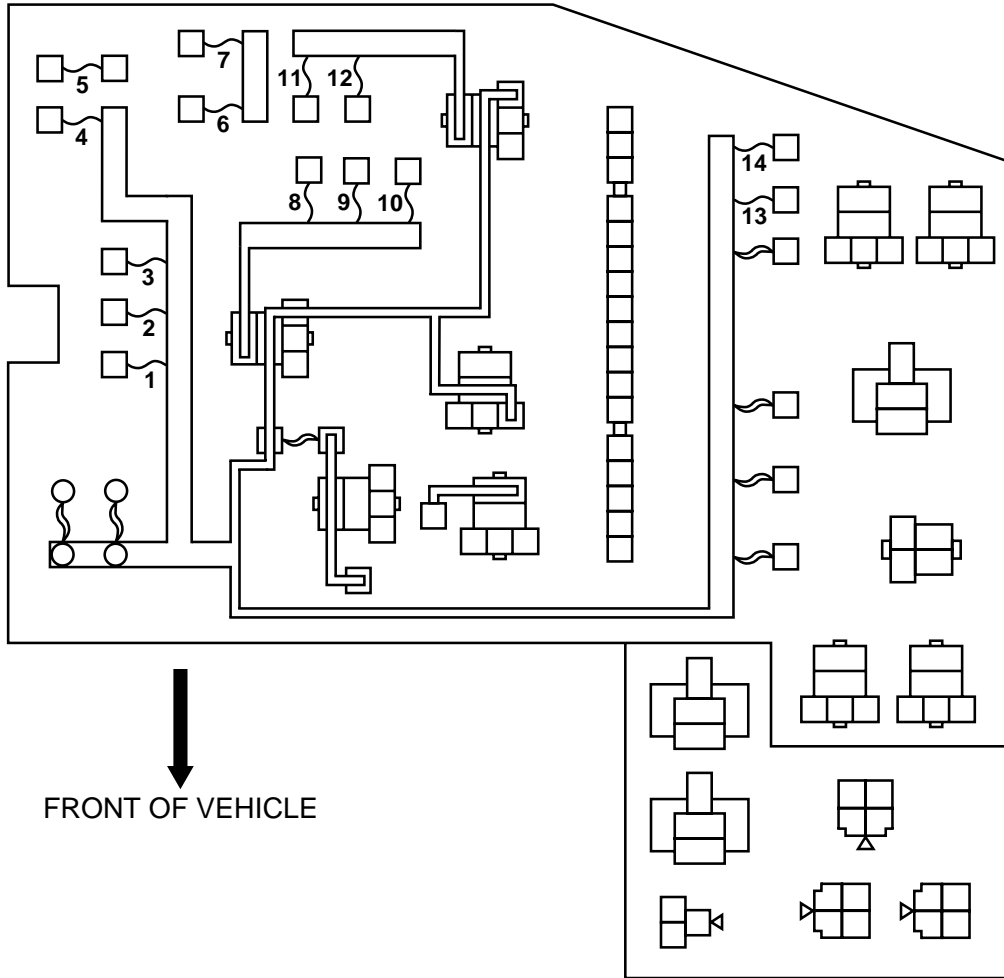

(CONNECTED TO JUNCTION BLOCK)

DEDICATED FUSES 15 TO 18

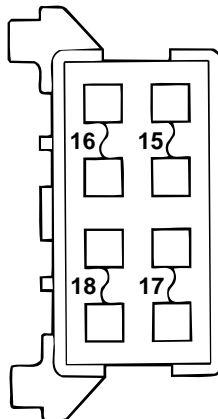

AC000314AC

MULTI-PURPOSE FUSE

POWER SUPPLY CIRCUIT	NO.	RATED CAPACITY (A)	HOUSING COLOR	LOAD CIRCUIT
Battery	1	30	Pink	Defogger and remote controlled mirror
	2	30	Pink	Blower motor
	3	15	Blue	Powertrain control module, ABS-ECU, stoplight, auto-cruise control-ECU and immobilizer-ECU
Ignition switch (IG1)	4	–	–	–
	5	10	Red	Powertrain control module, input shaft speed sensor, output shaft speed sensor, backup light and SRS-ECU
Ignition switch (ACC)	6	–	–	–
	7	15	Blue	Accessory socket, cigarette lighter and remote controlled mirror
	8	20	Yellow	ETACS-ECU and front-ECU
Ignition switch (IG2)	9	10	Red	Sunroof -ECU, ABS warning light relay and ABS-ECU
Battery	10	10	Red	Horn, horn relay, theft-alarm horn and theft-alarm horn relay
	11	15	Blue	Data link connector and ETACS-ECU
Ignition switch (IG1)	12	10	Red	Vehicle speed sensor
	13	10	Red	Combination meter, ETACS-ECU, SRS-ECU, auto-cruise control-ECU and column-ECU
Ignition switch (ACC)	14	–	–	–
Ignition switch (IG2)	15	–	–	–
	16	10	Red	Blower relay, outside/inside air selection damper control motor, defogger relay, A/C switch, front-ECU, A/C compressor relay and automatic compressor controller

(IN JUNCTION BLOCK)

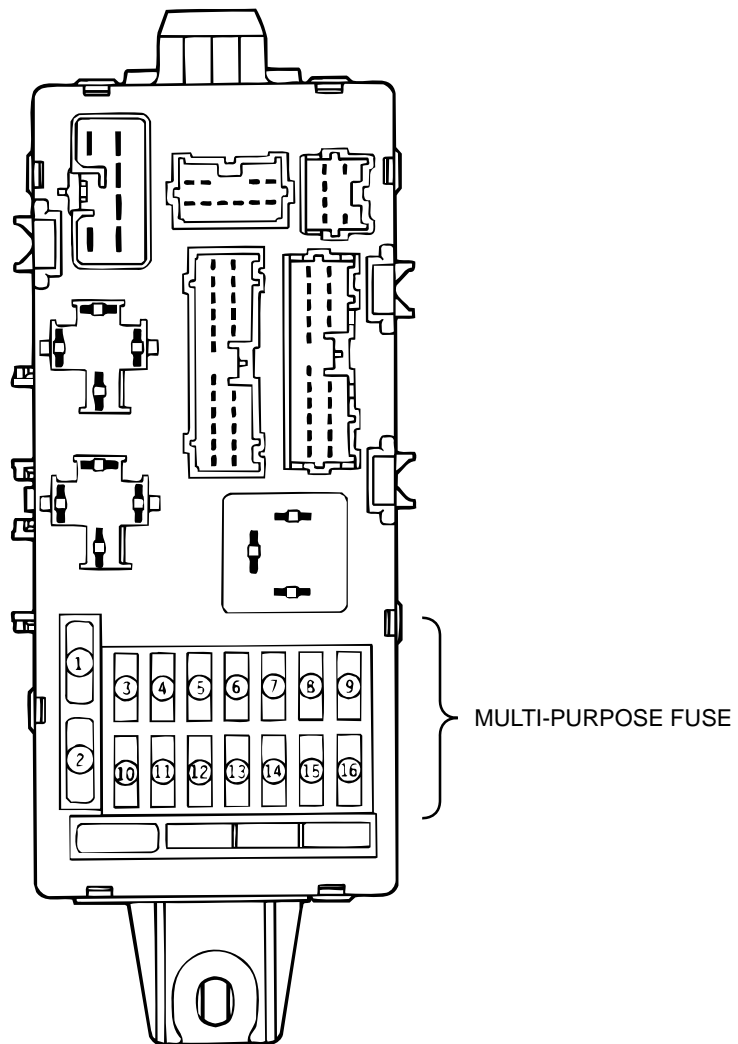

AC000315AB

CENTRALIZED RELAY

CONNECTOR NO.	NAME	CONNECTOR NO.	NAME
A-04X	Power window relay	A-13X	Fan control relay
A-05X	Taillight relay	A-14X	A/C compressor relay
A-06X	Fog light relay	A-15X	Horn relay
A-07X	Headlight relay (High)	A-16X	Inspection connector
A-08X	Headlight relay (Low)	A-17X	–
A-09X	Front-ECU	A-18X	–
A-10X	ABS warning light relay	A-19X	A/T control relay
A-11X	Theft-alarm horn relay	A-20X	Fuel pump relay
A-12X	–	A-21X	MFI relay

(RELAY BOX IN ENGINE COMPARTMENT)

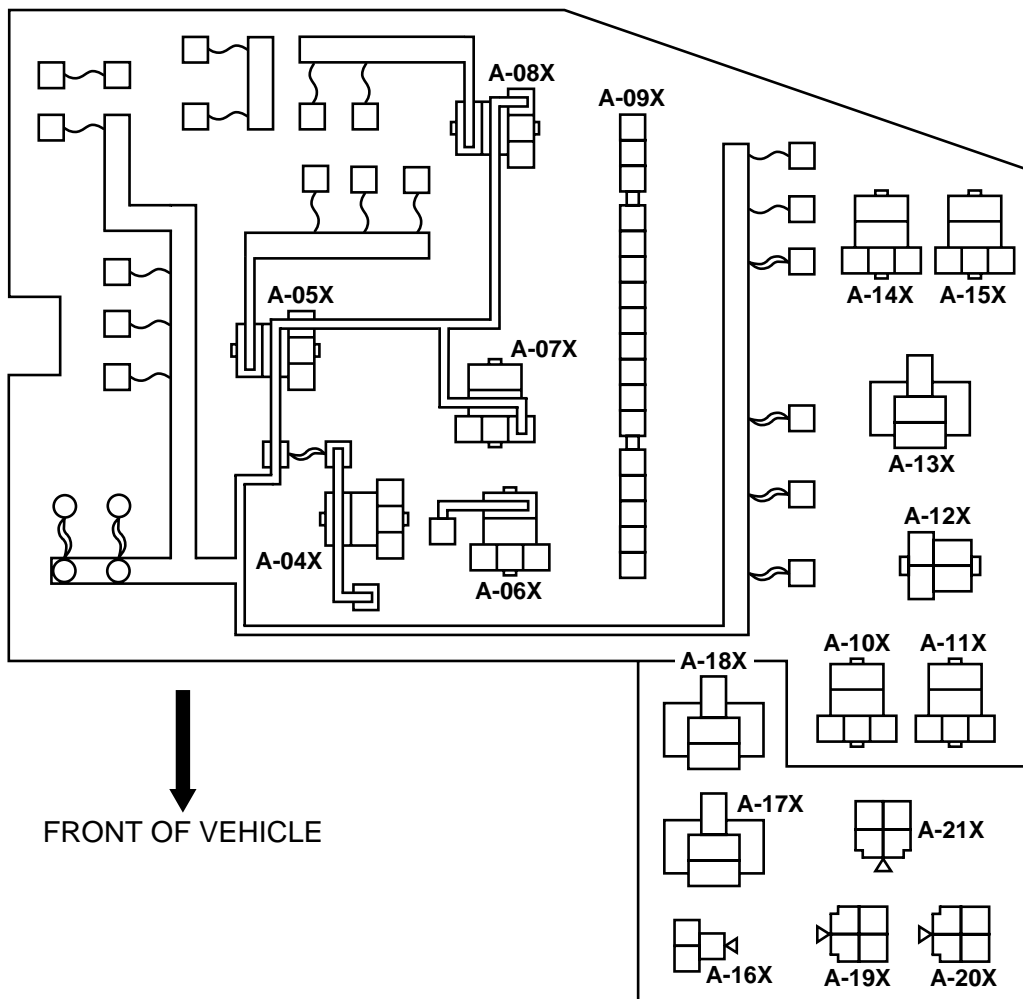

AC000312AC

TSB Revision

POWER DISTRIBUTION SYSTEM

M1901000400051

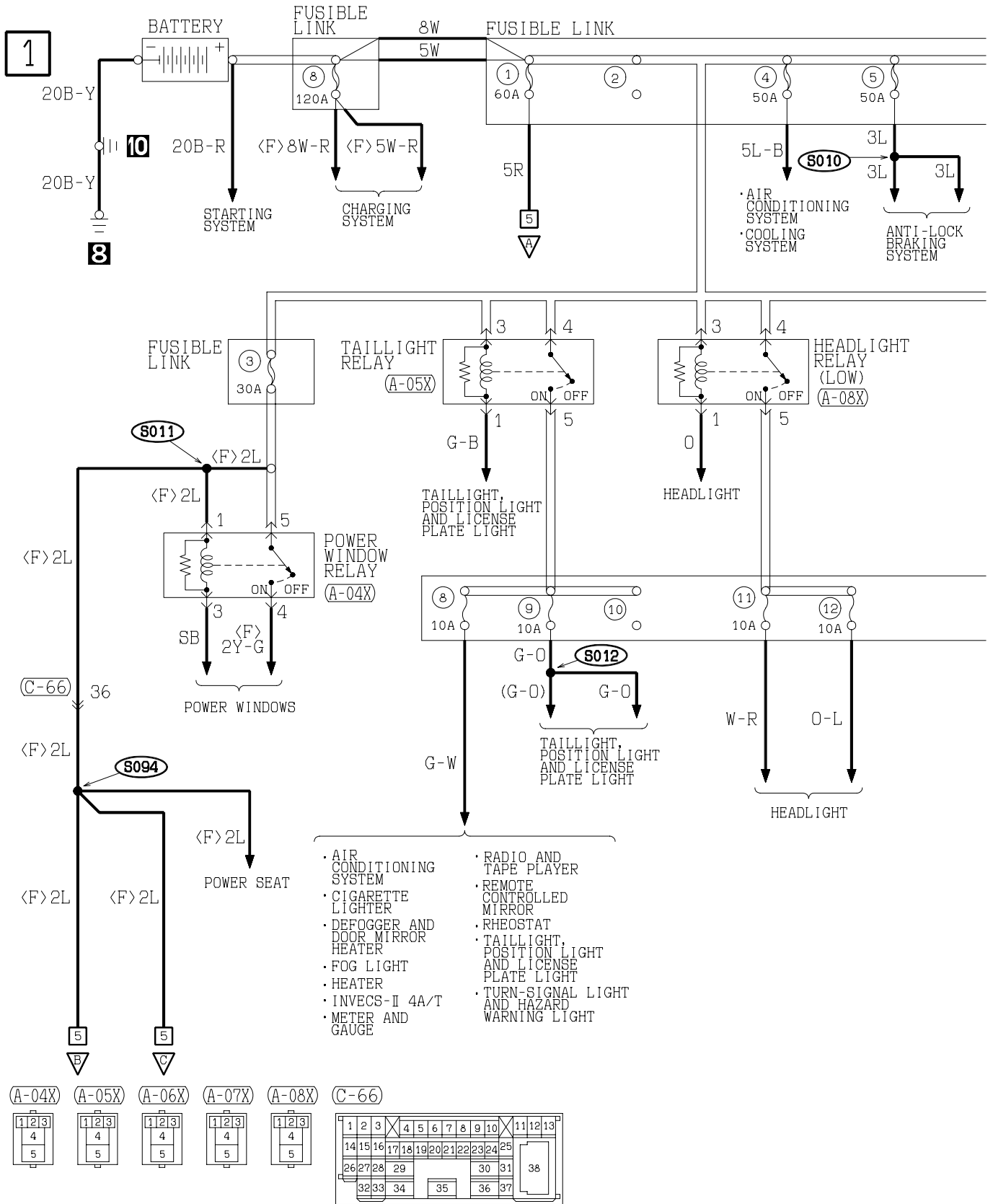

H1S01M01AA

2

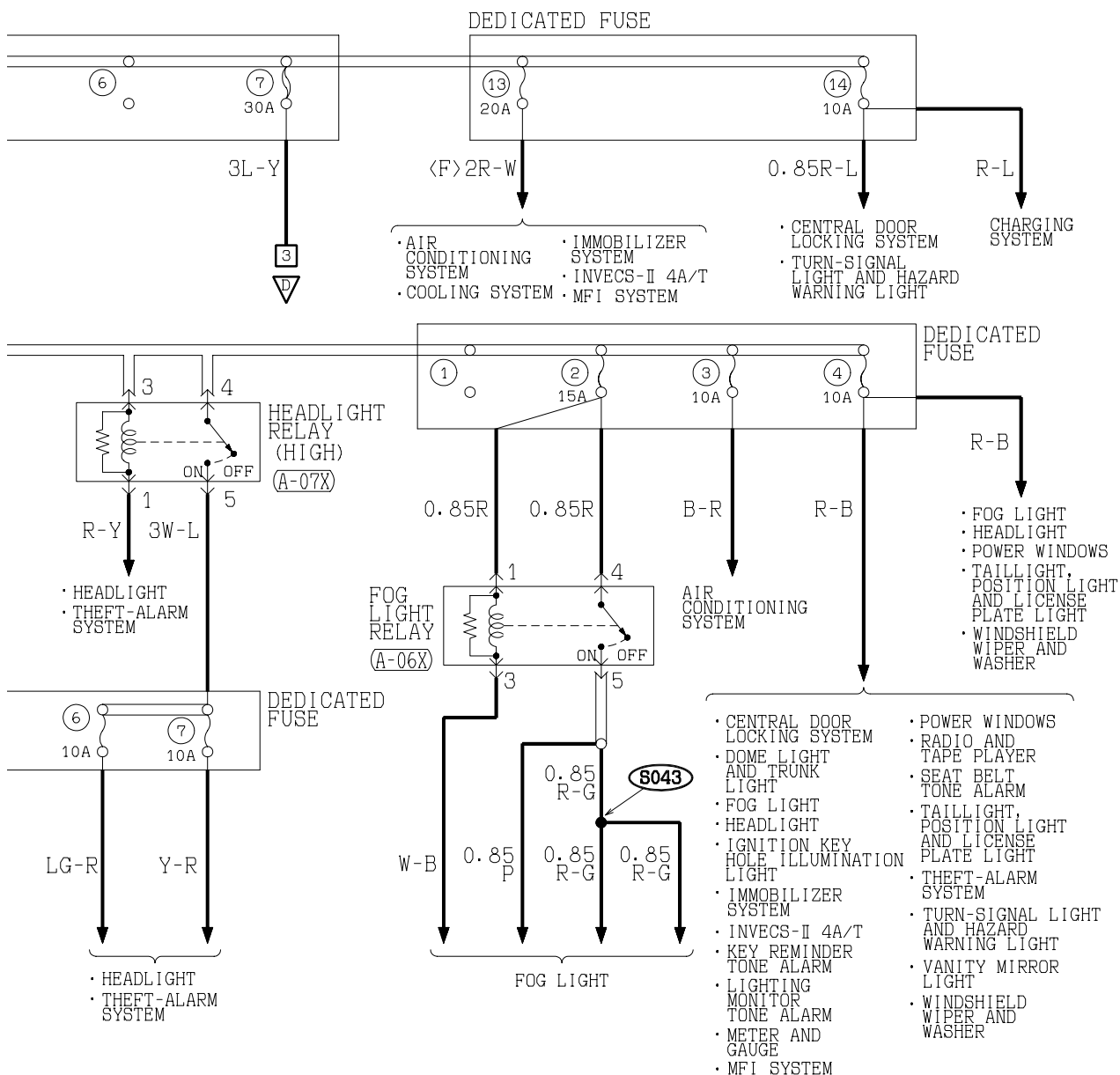

WIRE COLOR CODE
 B : BLACK BR : BROWN G : GREEN GR : GRAY L : BLUE LG : LIGHT GREEN O : ORANGE
 P : PINK R : RED SB : SKY BLUE V : VIOLET W : WHITE Y : YELLOW

TSB Revision

POWER DISTRIBUTION SYSTEM (CONTINUED)

3

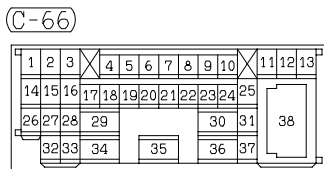
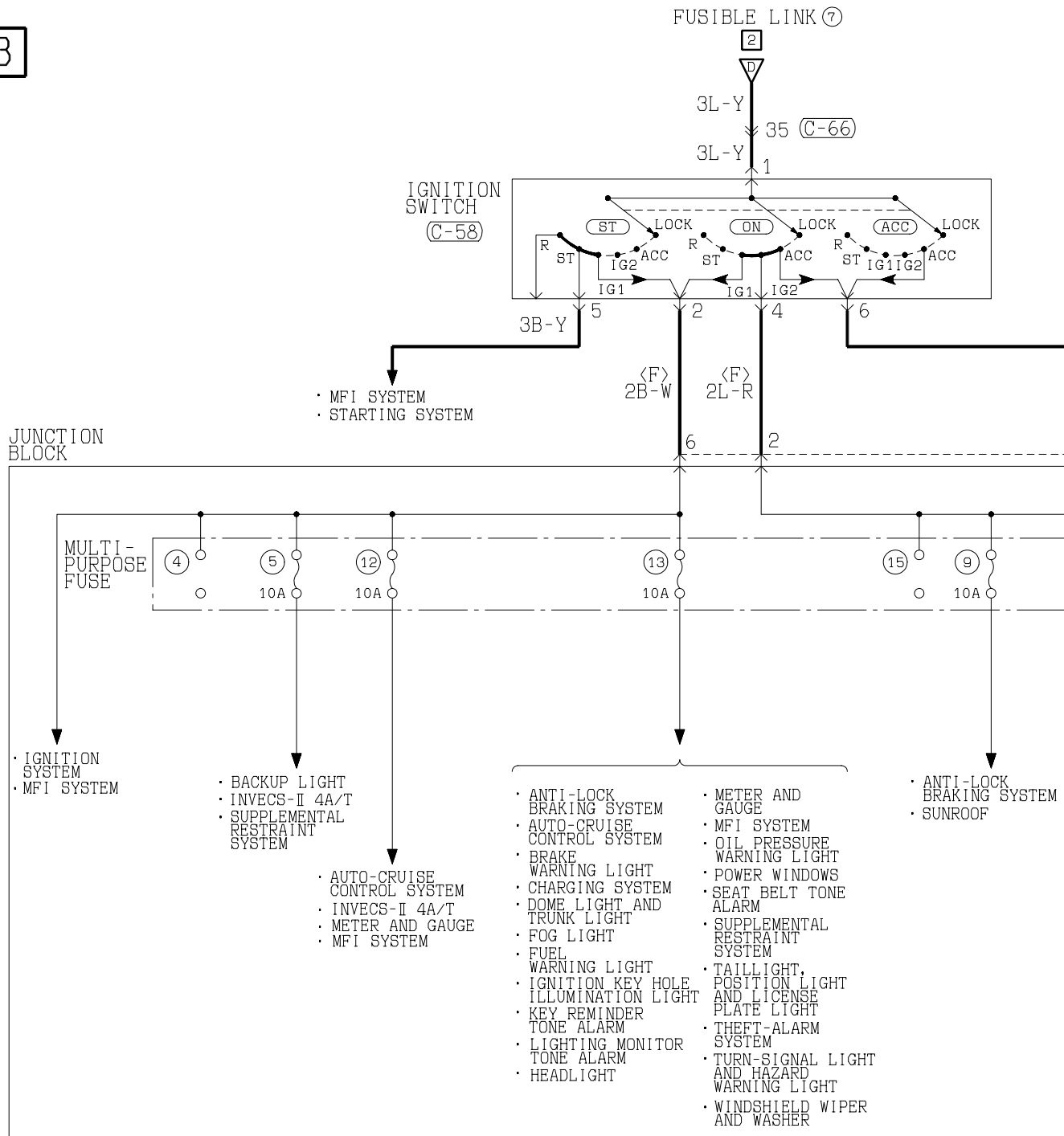

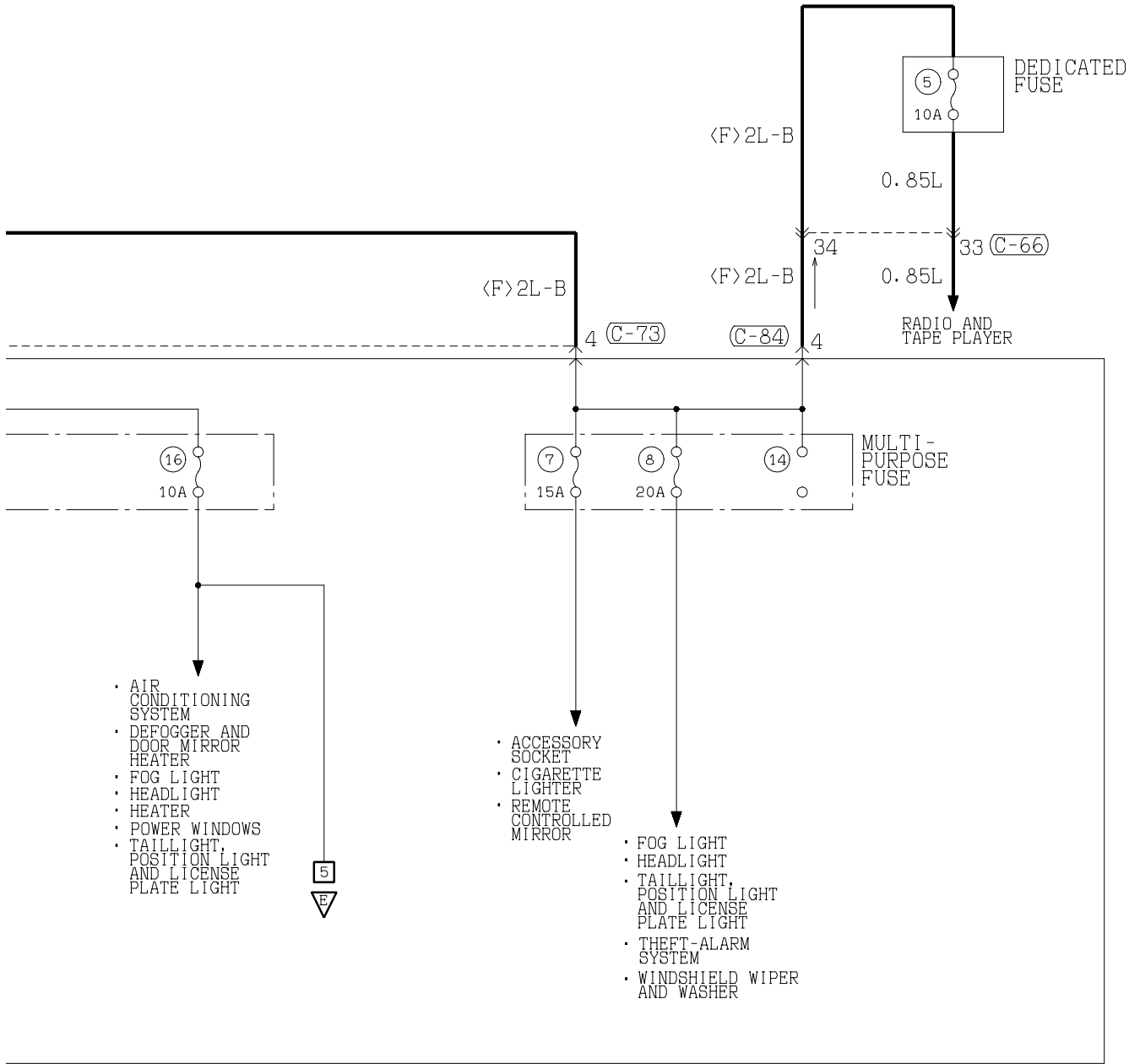

WIRE COLOR	CODE	G : GREEN	GR : GRAY	L : BLUE	LG : LIGHT GREEN	O : ORANGE
B : BLACK	BR : BROWN	SB : SKY BLUE	V : VIOLET	W : WHITE	Y : YELLOW	
P : PINK	R : RED					

H1801M01BB

TSB Revision

POWER DISTRIBUTION SYSTEM (CONTINUED)

5

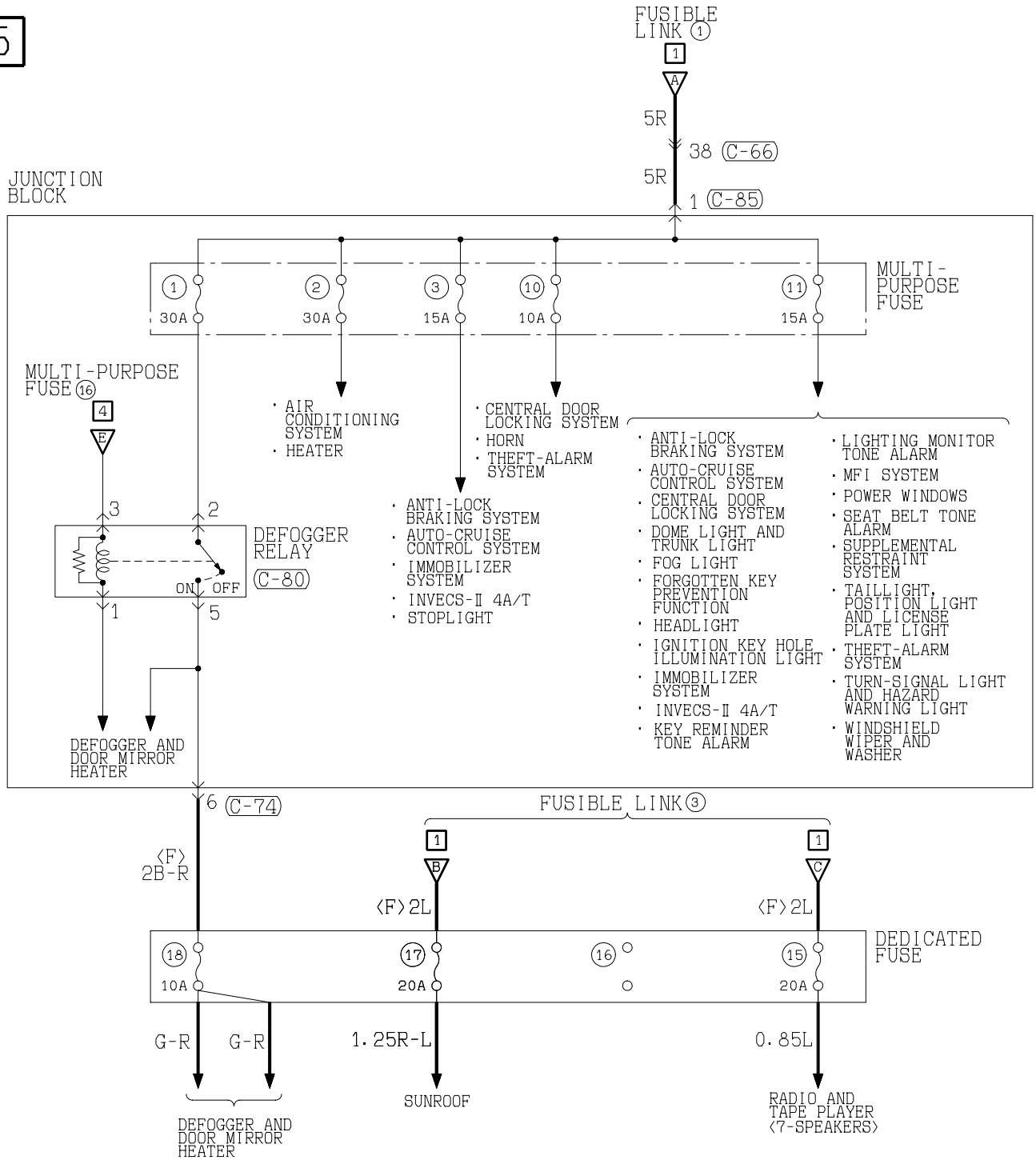

(C-66)

1	2	3	4	5	6	7	8	9	10	11	12	13
14	15	16	17	18	19	20	21	22	23	24	25	
26	27	28	29			30	31					
32	33	34	35			36	37					

(C-74)

1	2	3	4
5	6	7	8
9	10		

(C-80)

1	2	3
4	5	

(C-85)

1

WIRE COLOR CODE

B : BLACK BR: BROWN G : GREEN GR: GRAY
L : BLUE LG: LIGHT GREEN O : ORANGE P : PINK
R : RED SB: SKY BLUE V : VIOLET W : WHITE
Y : YELLOW

H1S01M01CA

TSB Revision

STARTING SYSTEM

M1901000500069

1

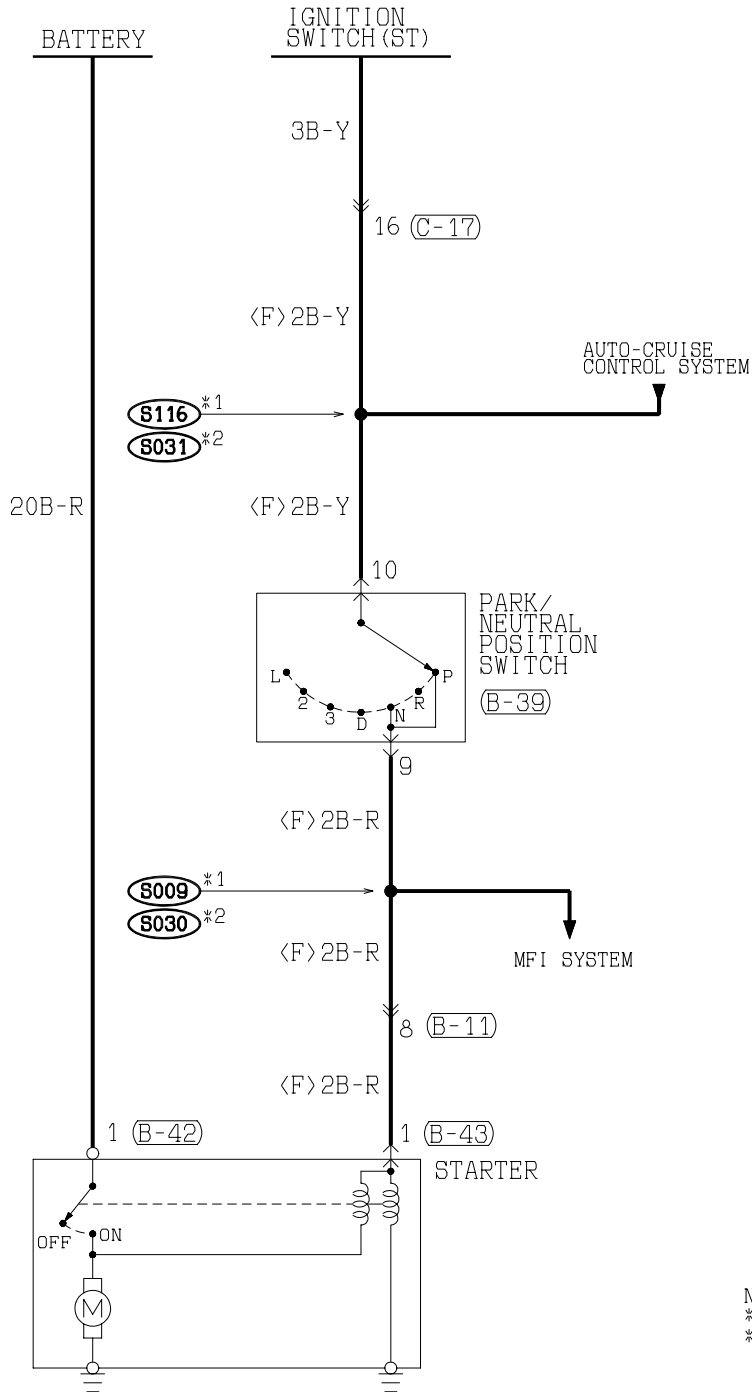

NOTE
*1: 2.4L ENGINE
*2: 3.0L ENGINE

(B-11)
MU802749

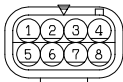

(B-39)
MU802355

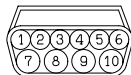

(B-42) ①

(B-43) ①

(C-17)

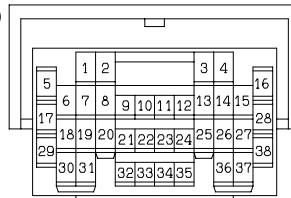

WIRE COLOR CODE

B : BLACK LG : LIGHT GREEN G : GREEN L : BLUE
BR : BROWN O : ORANGE GR : GRAY R : RED
W : WHITE SB : SKY BLUE P : PINK Y : YELLOW
V : VIOLET

H1S02M02AA

TSB Revision

IGNITION SYSTEM <2.4L ENGINE>

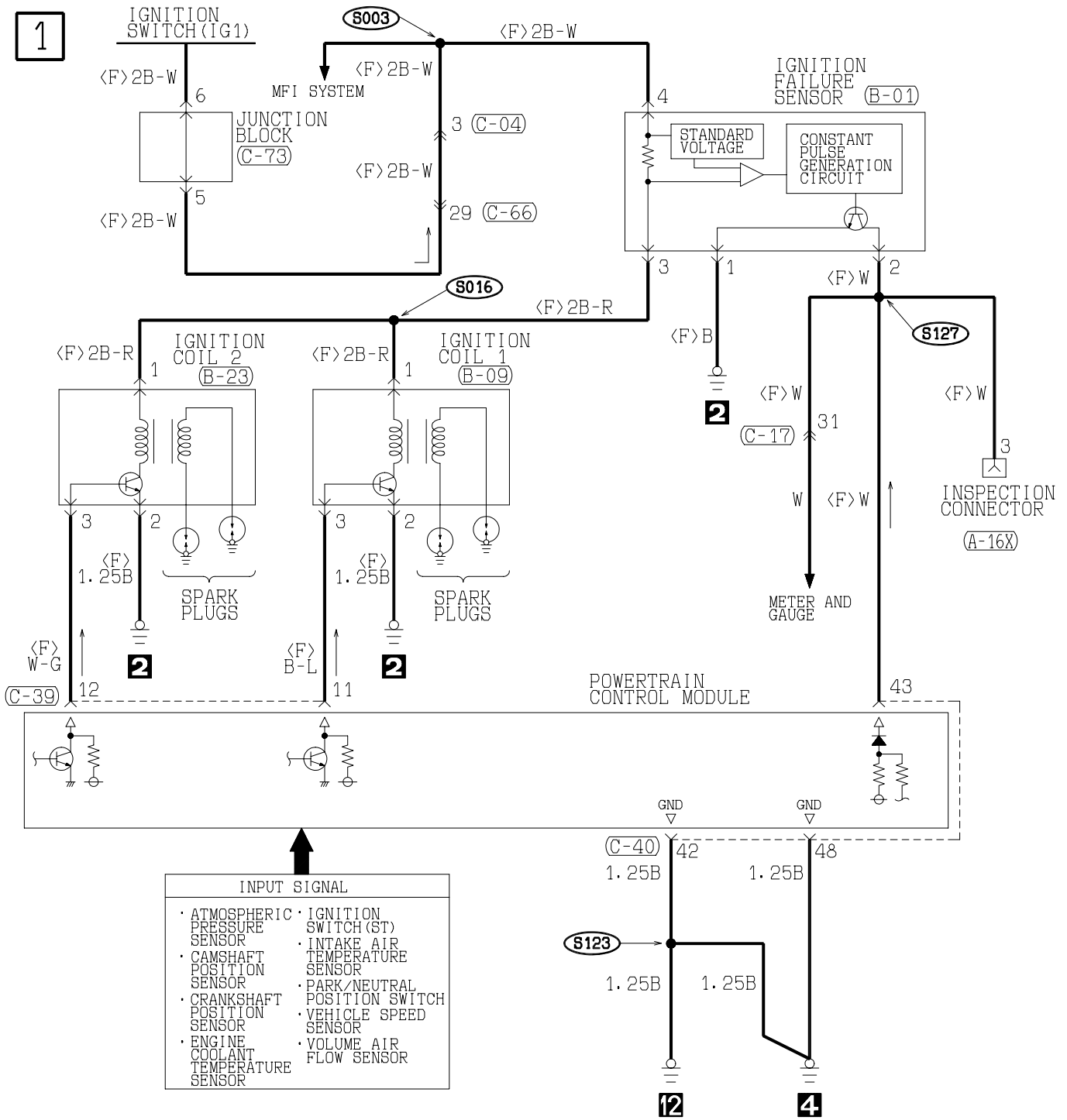

- INPUT SIGNAL**
- ATMOSPHERIC PRESSURE SENSOR
 - CAMSHAFT POSITION SENSOR
 - CRANKSHAFT POSITION SENSOR
 - ENGINE COOLANT TEMPERATURE SENSOR
 - IGNITION SWITCH (ST)
 - INTAKE AIR TEMPERATURE SENSOR
 - PARK/NEUTRAL POSITION SWITCH
 - VEHICLE SPEED SENSOR
 - VOLUME AIR FLOW SENSOR

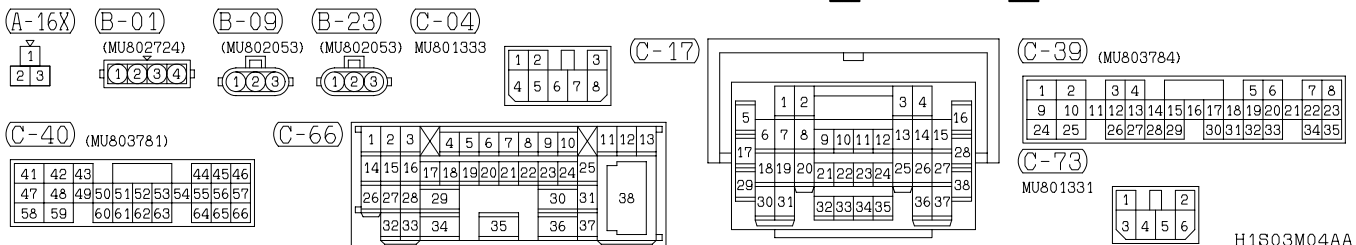

TSB Revision

IGNITION SYSTEM <3.0L ENGINE>

M1901000600099

1

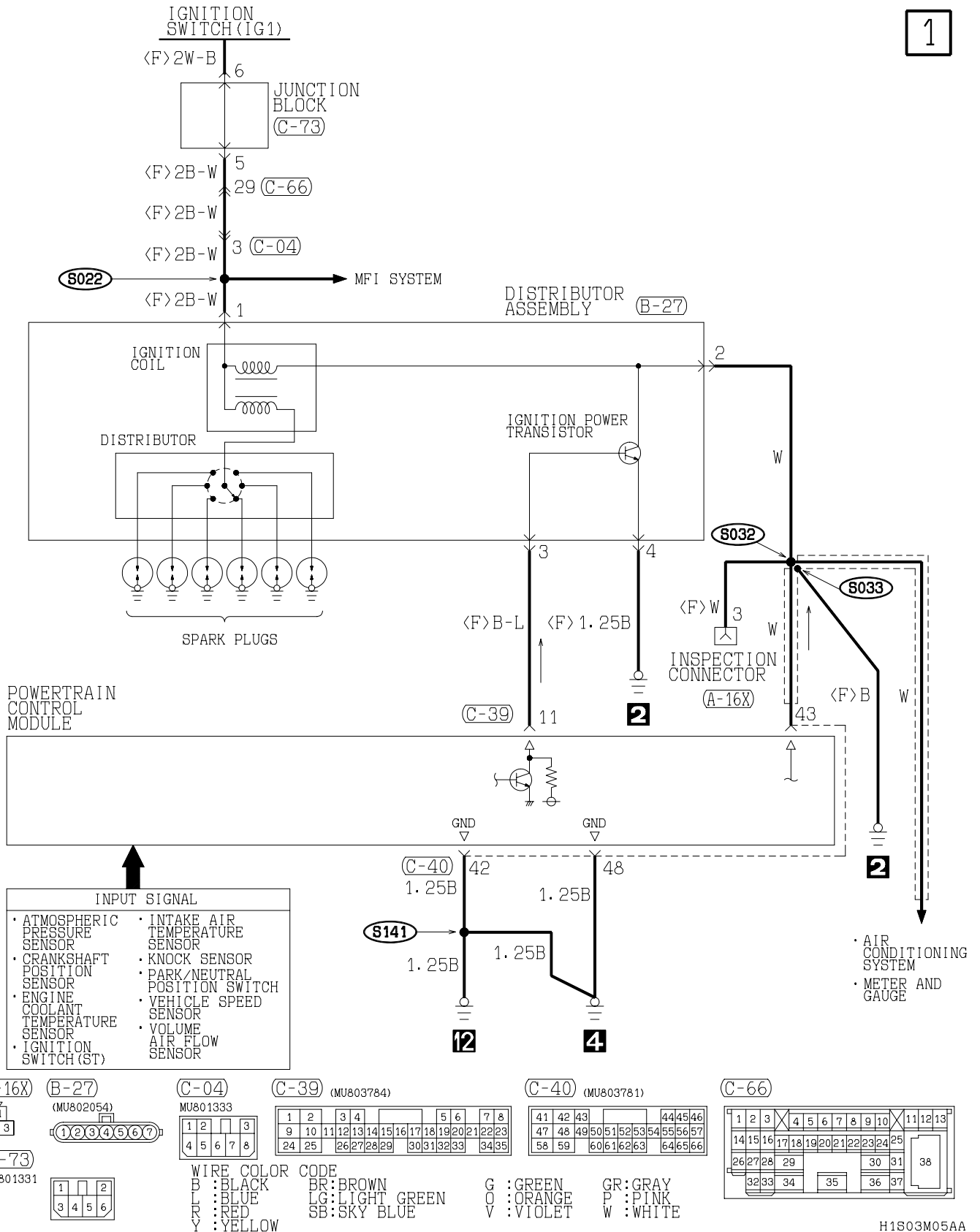

TSB Revision

H1S03M05AA

CHARGING SYSTEM

1

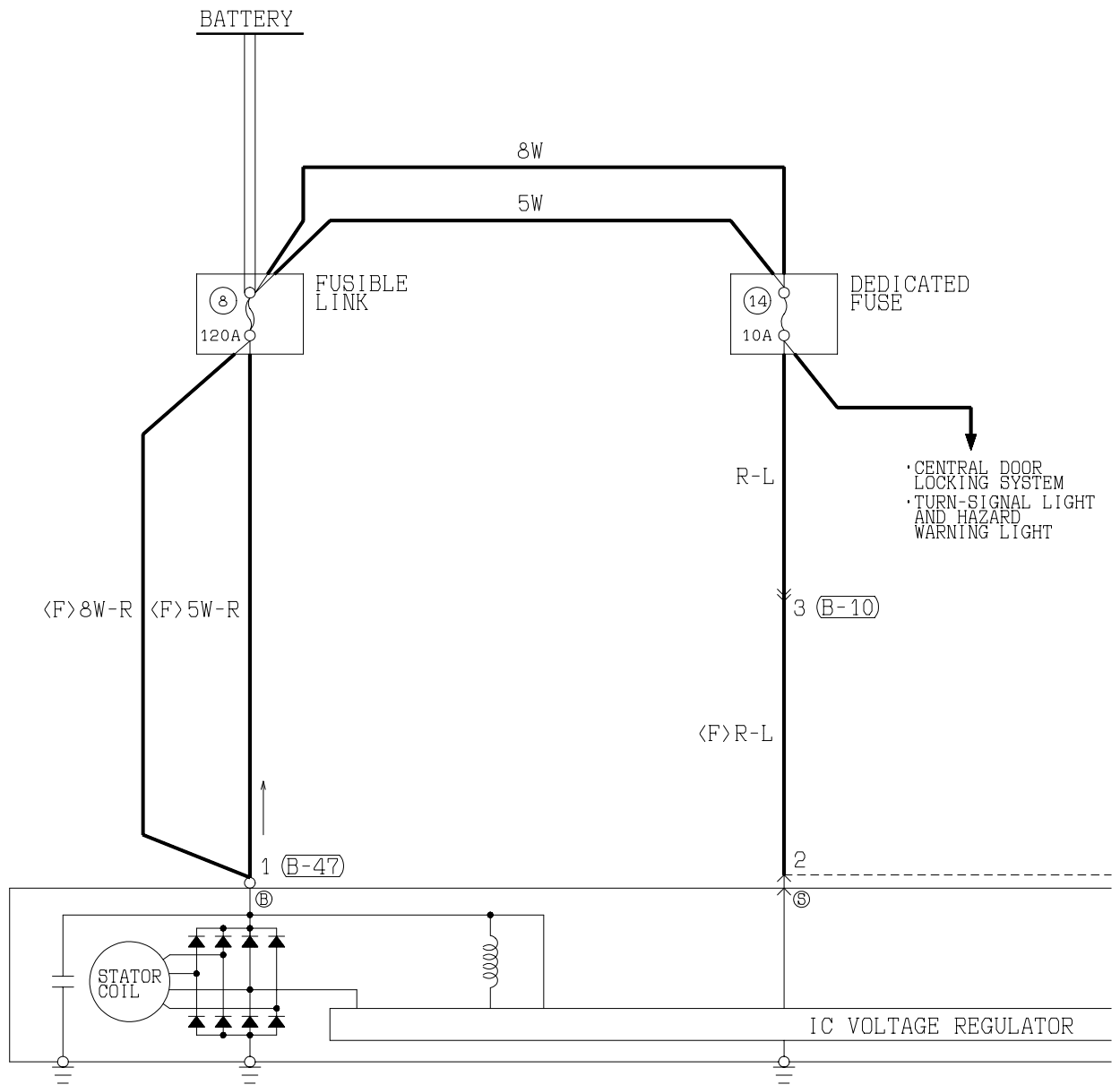

(B-10)
MU802351



(B-11)
MU802749

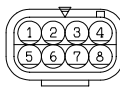

(B-46)
(MU802046)

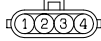

(B-47)
1

(C-29)

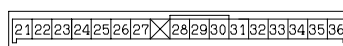

(C-30)

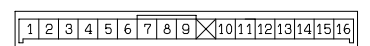

TSB Revision

2

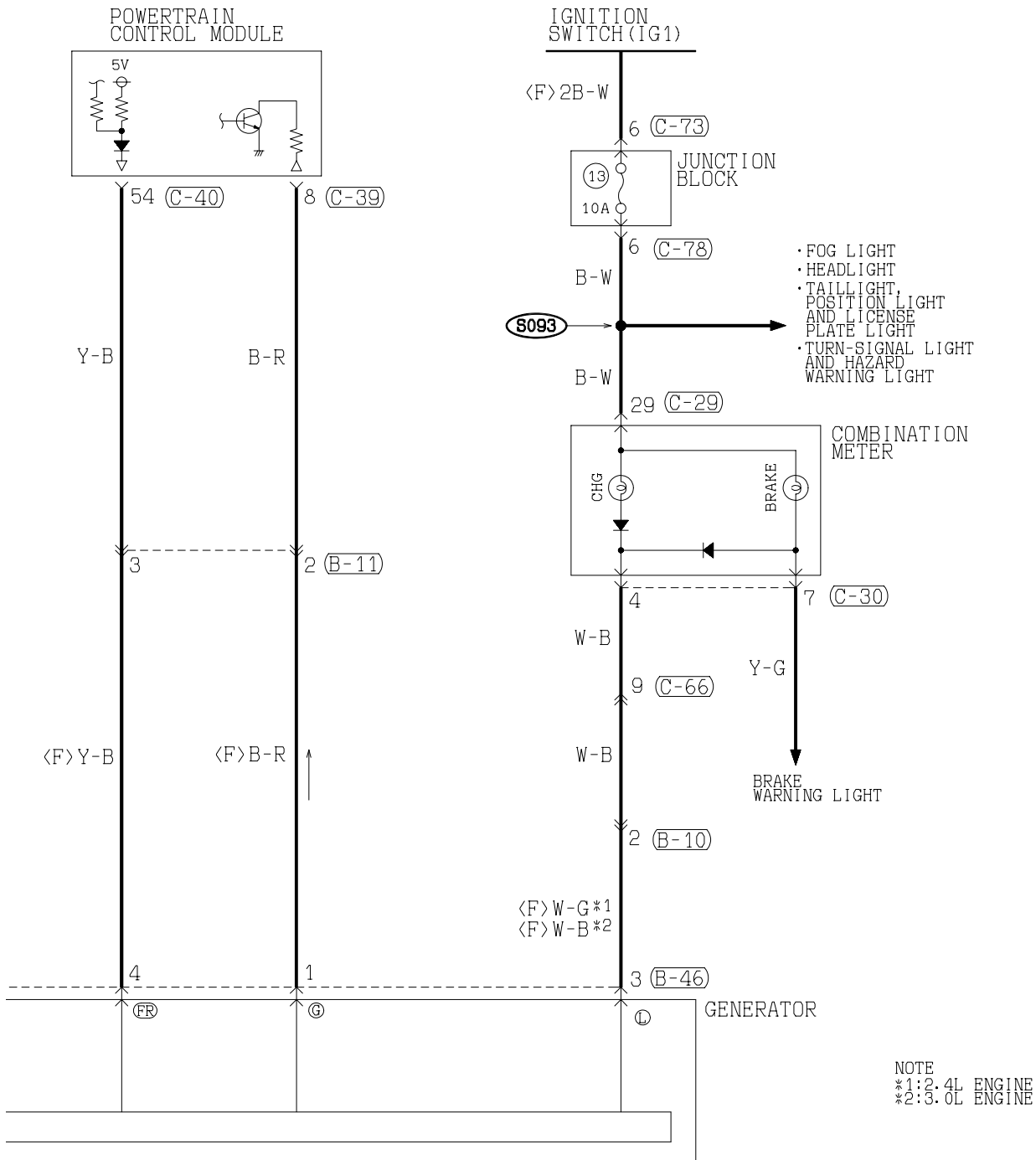

(C-39) (MU803784)

1	2	3	4	5	6	7	8
9	10	11	12	13	14	15	16
17	18	19	20	21	22	23	24
25	26	27	28	29	30	31	32
33	34	35					

(C-40) (MU803781)

41	42	43	44	45	46
47	48	49	50	51	52
53	54	55	56	57	58
59	60	61	62	63	64
65	66				

(C-66)

1	2	3	4	5	6	7	8	9	10	11	12	13
14	15	16	17	18	19	20	21	22	23	24	25	26
27	28	29	30	31	32	33	34	35	36	37	38	

(C-73)

1	2
3	4
5	6

(C-78)

1	2	3	4	5	6	7	8	9
10	11	12	13	14	15	16	17	18
19	20							

WIRE COLOR CODE
B : BLACK BR : BROWN
P : PINK R : RED

G : GREEN
SB : SKY BLUE

GR : GRAY
V : VIOLET

L : BLUE
W : WHITE

LG : LIGHT GREEN
Y : YELLOW

O : ORANGE

H1S04M02AB

TSB Revision

MFI SYSTEM <2.4L ENGINE>

M1901000800082

1

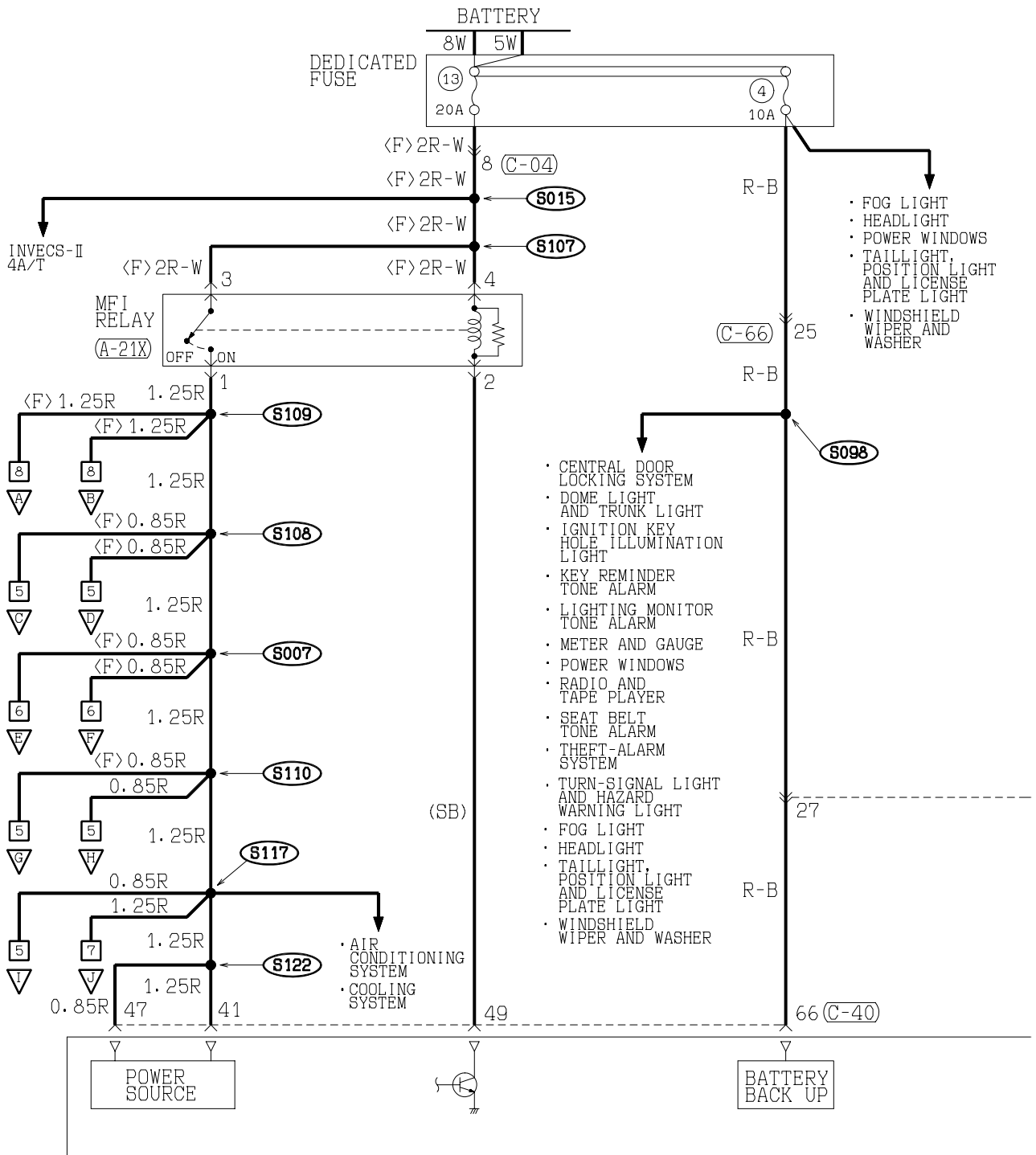

(A-20X)



(A-21X)



(B-16)



(MU801211) (MU801333)

(C-04)

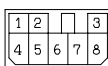

(C-17)

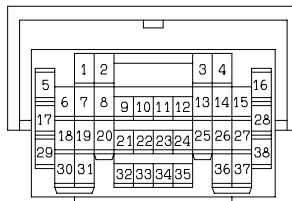

(C-29)

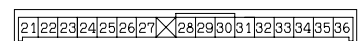

(C-30)

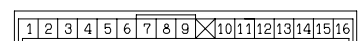

(C-71)

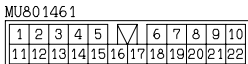

(C-73)

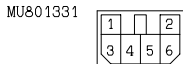

H1S05M04AA

TSB Revision

2

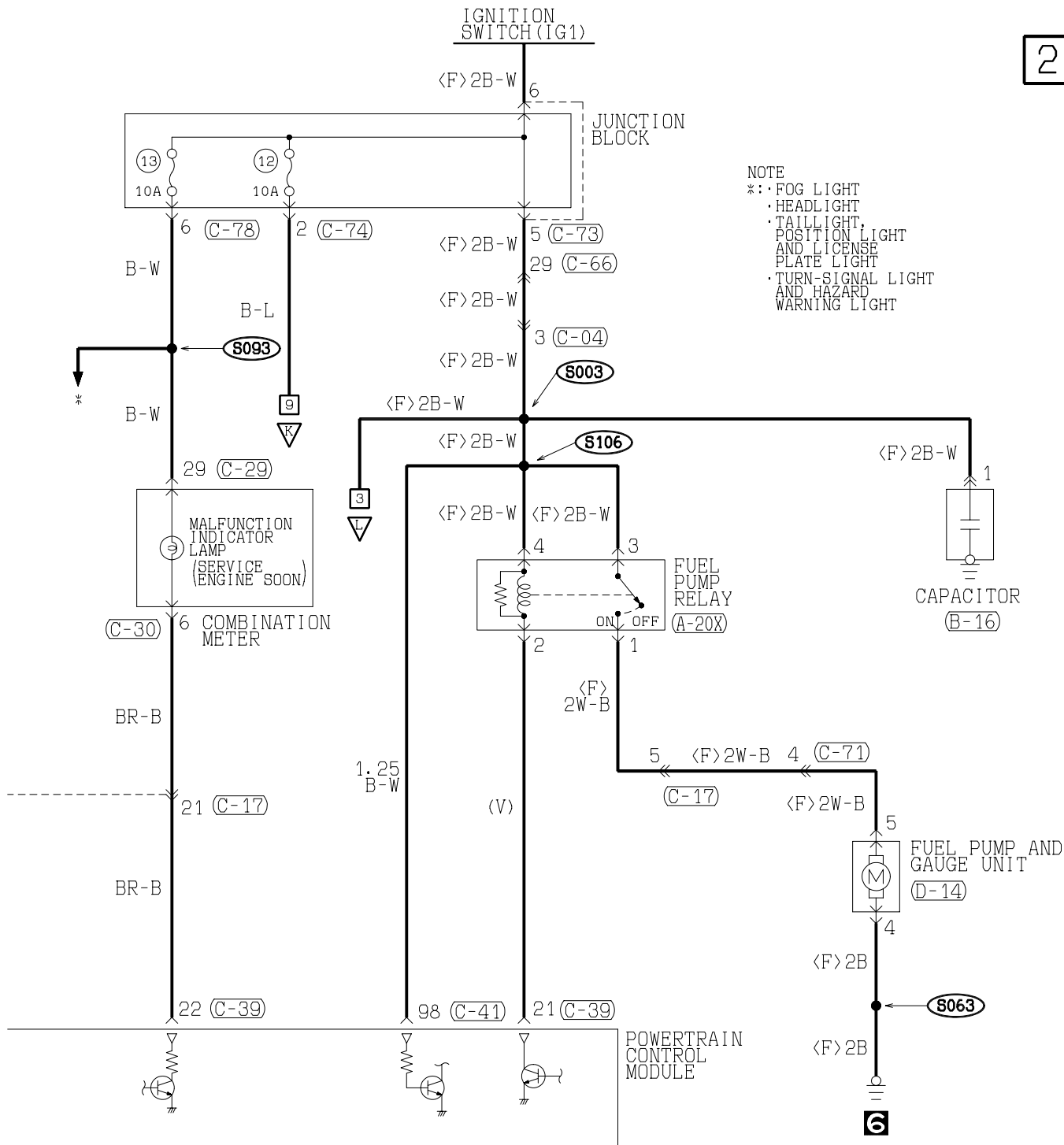

(C-39) (MU803784)

1	2	3	4	5	6	7	8							
9	10	11	12	13	14	15	16	17	18	19	20	21	22	23
24	25	26	27	28	29	30	31	32	33	34	35			

(C-40) (MU803781)

41	42	43	44	45	46	75	76	77														
47	48	49	50	51	52	53	54	55	56	57	78	79	80	81	82	83	84	85	86	87	88	89
58	59	60	61	62	63	64	65	66	90	91	92	93	94	95	96	97	98					

(C-41) (MU803782)

71	72	73	74	75	76	77					
78	79	80	81	82	83	84	85	86	87	88	89
90	91	92	93	94	95	96	97	98			

(C-66)

1	2	3	4	5	6	7	8	9	10	11	12	13
14	15	16	17	18	19	20	21	22	23	24	25	38
26	27	28	29	30	31	32	33	34	35	36	37	

G : GREEN GR : GRAY
O : ORANGE P : PINK
V : VIOLET W : WHITE

(C-74)

MU801451

1	2	3	4		
5	6	7	8	9	10

(C-78)

MU801457

1	2	3	4	5	6	7	8	9		
10	11	12	13	14	15	16	17	18	19	20

(D-14)

(MU802058)

1	2	3
4	5	

WIRE COLOR CODE
B : BLACK BR : BROWN
L : BLUE LG : LIGHT GREEN
R : RED SB : SKY BLUE
Y : YELLOW

H1S05M04AB

TSB Revision

MFI SYSTEM <2.4L ENGINE> (CONTINUED)

3

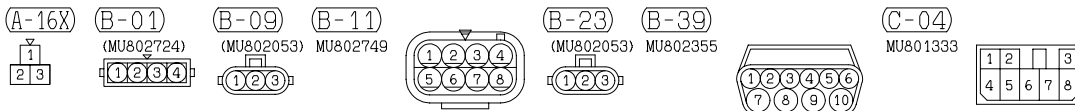
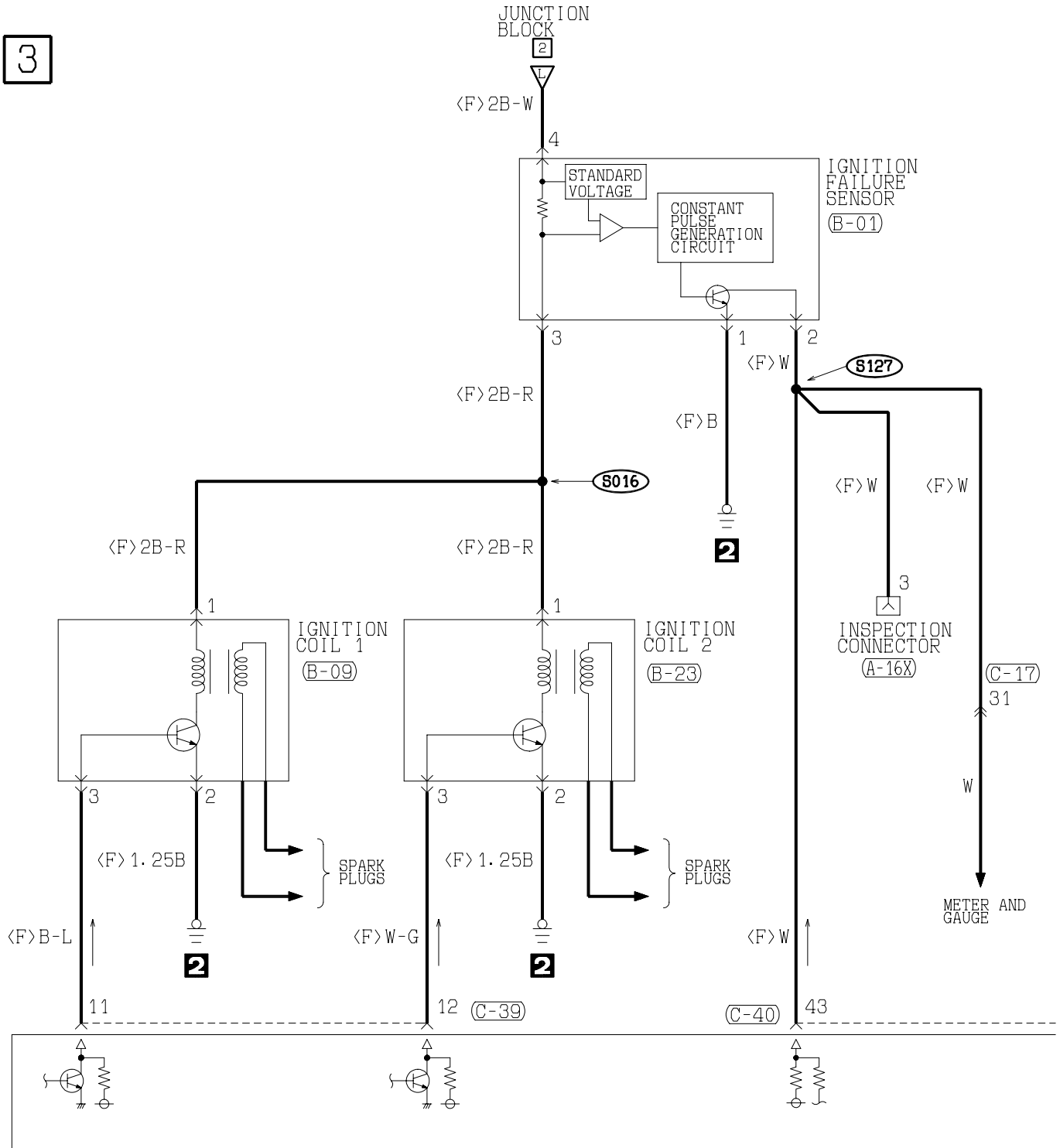

TSB Revision

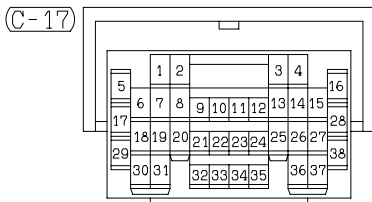
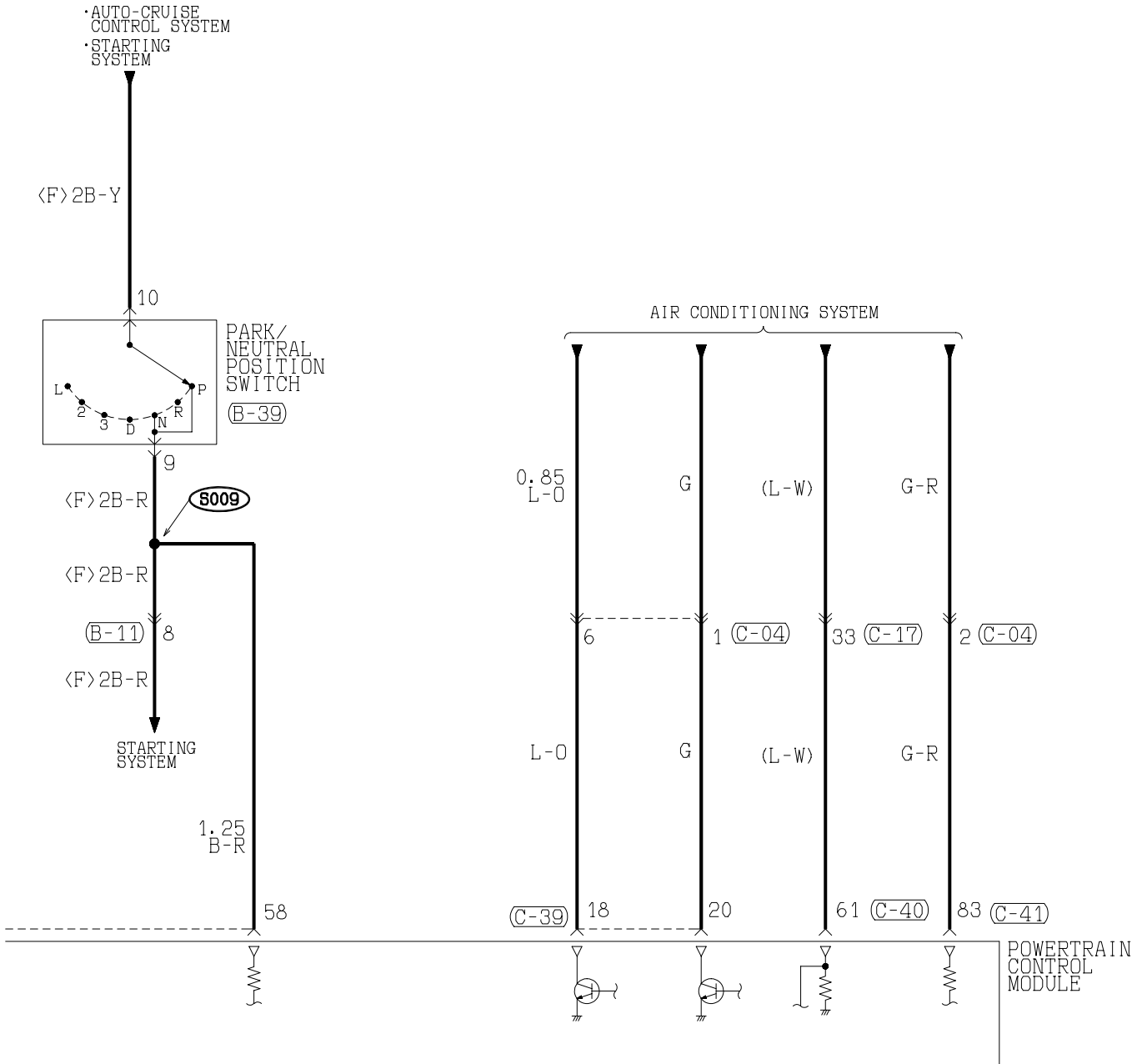

(C-39) (MU803784)

1	2	3	4	5	6	7	8
9	10	11	12	13	14	15	16
17	18	19	20	21	22	23	24
25	26	27	28	29	30	31	32
33	34	35					

(C-40) (MU803781)

41	42	43	44	45	46
47	48	49	50	51	52
53	54	55	56	57	58
59	60	61	62	63	64
65	66				

(C-41) (MU803782)

71	72	73	74	75	76	77
78	79	80	81	82	83	84
85	86	87	88	89	90	91
92	93	94	95	96	97	98

WIRE COLOR CODE

B : BLACK LG : LIGHT GREEN G : GREEN L : BLUE

BR : BROWN O : ORANGE GR : GRAY R : RED

W : WHITE SB : SKY BLUE P : PINK Y : YELLOW

V : VIOLET

H1S05M04BB

TSB Revision

MFI SYSTEM <2.4L ENGINE> (CONTINUED)

5

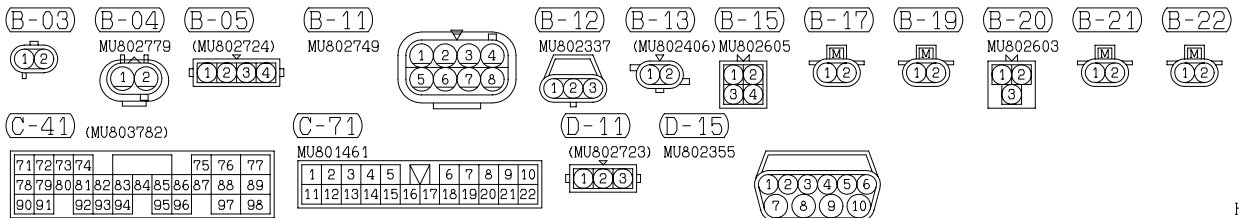
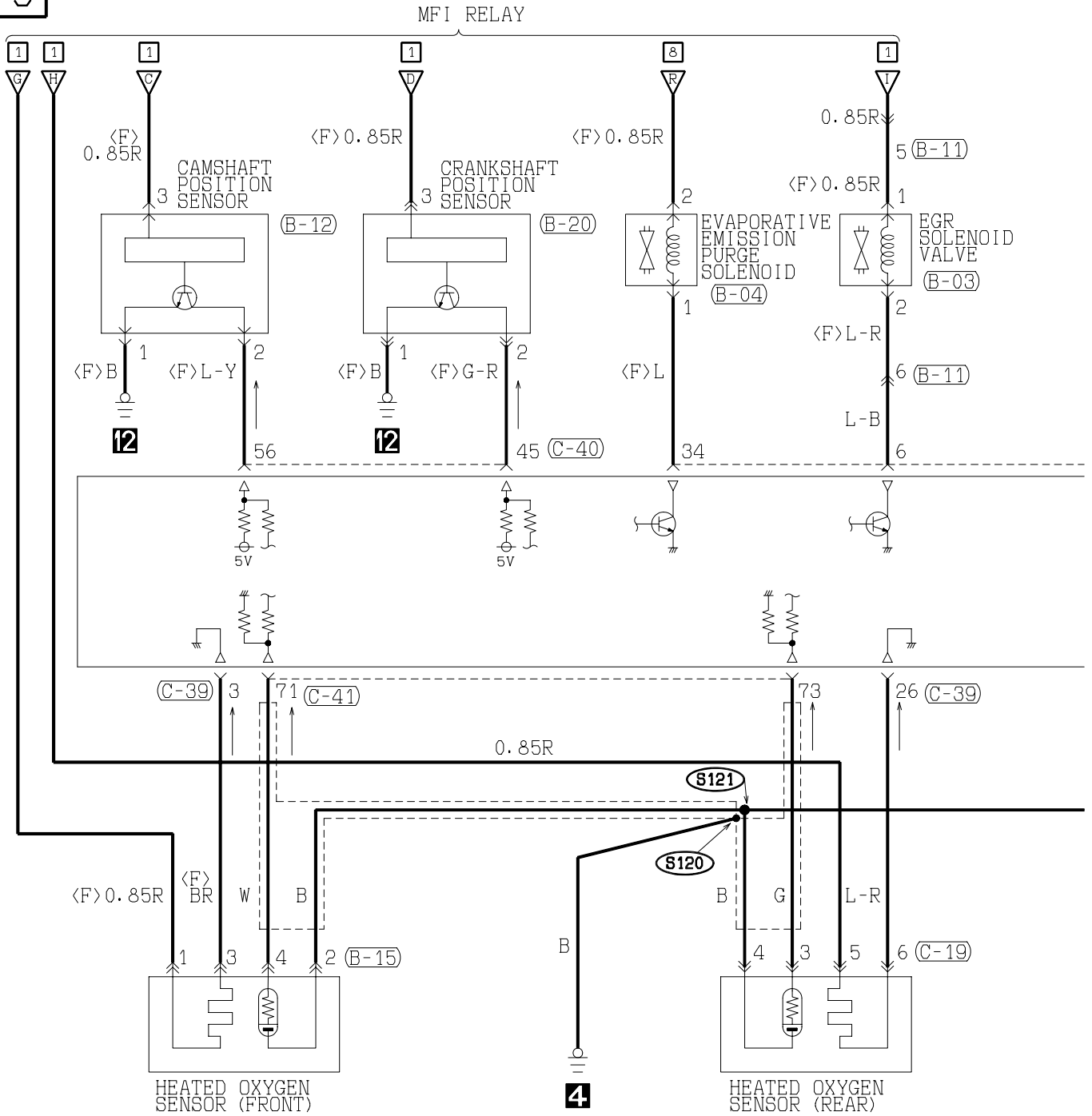

H1S05M04CA

TSB Revision

6

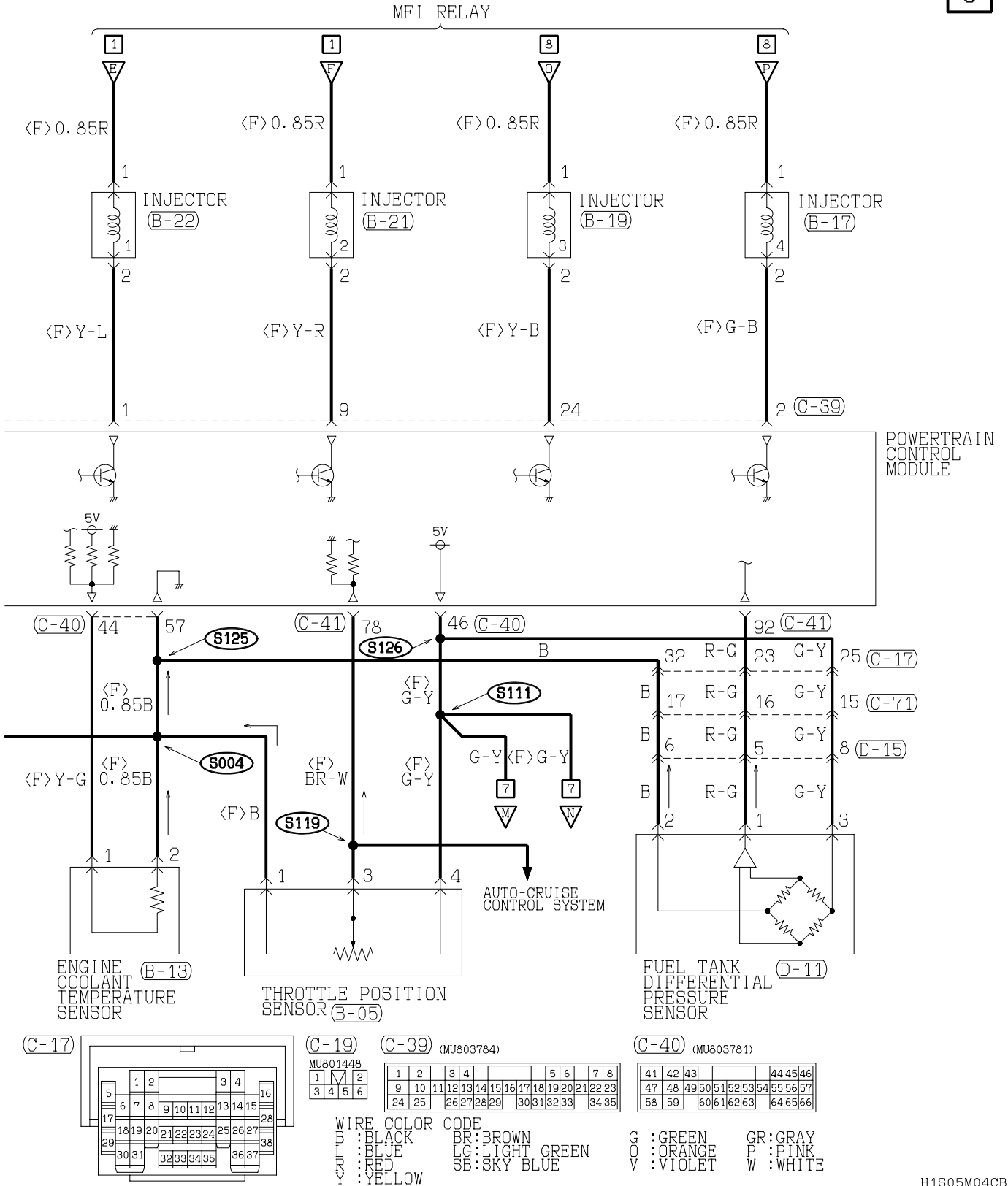

TSB Revision

MFI SYSTEM <2.4L ENGINE> (CONTINUED)

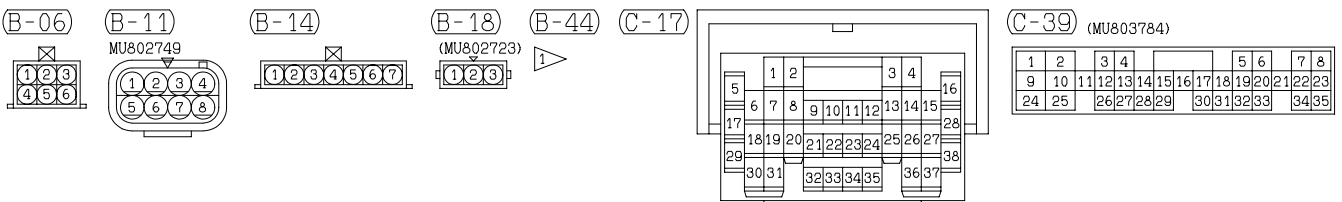
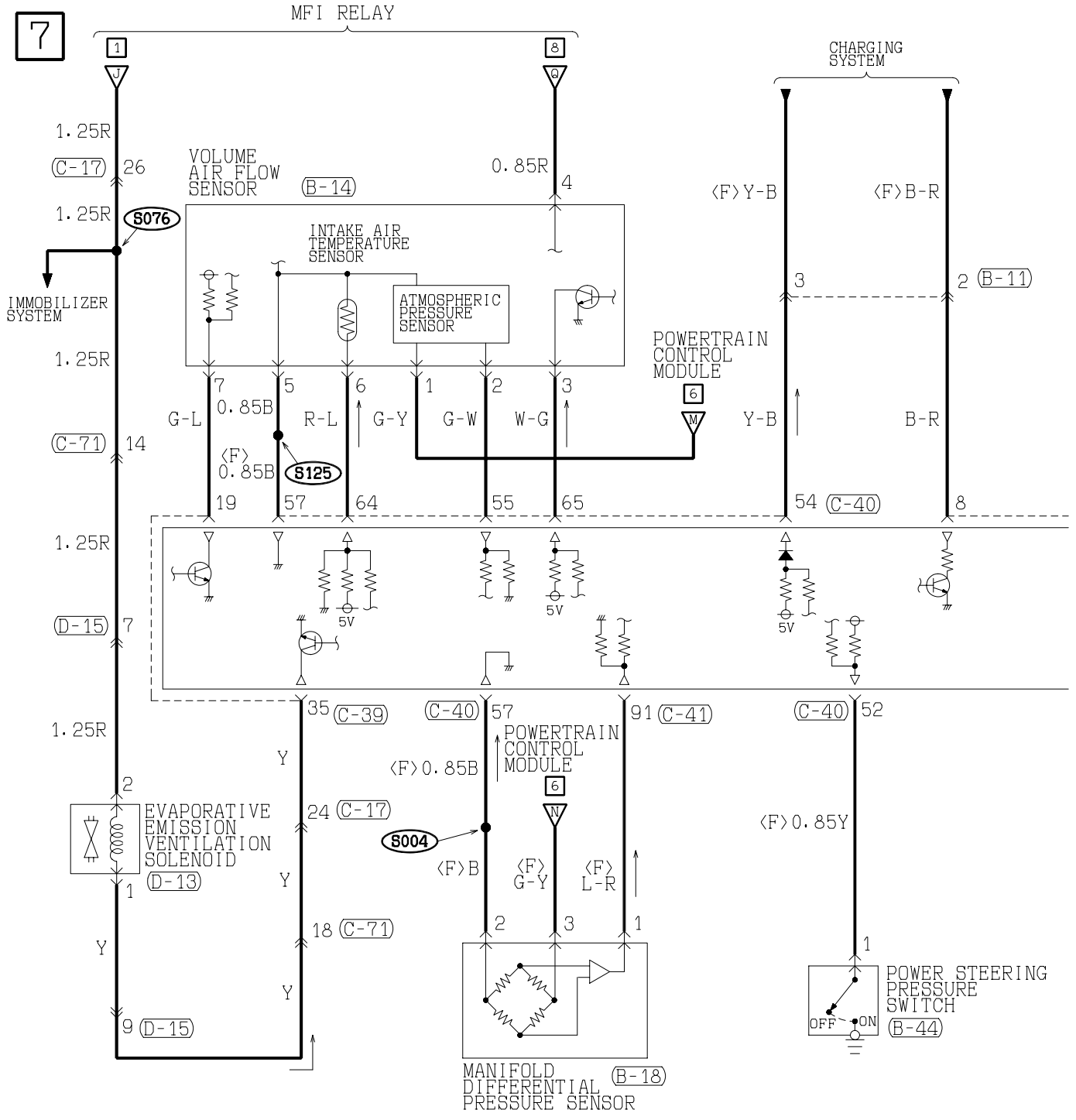

H1S05M04DA

8

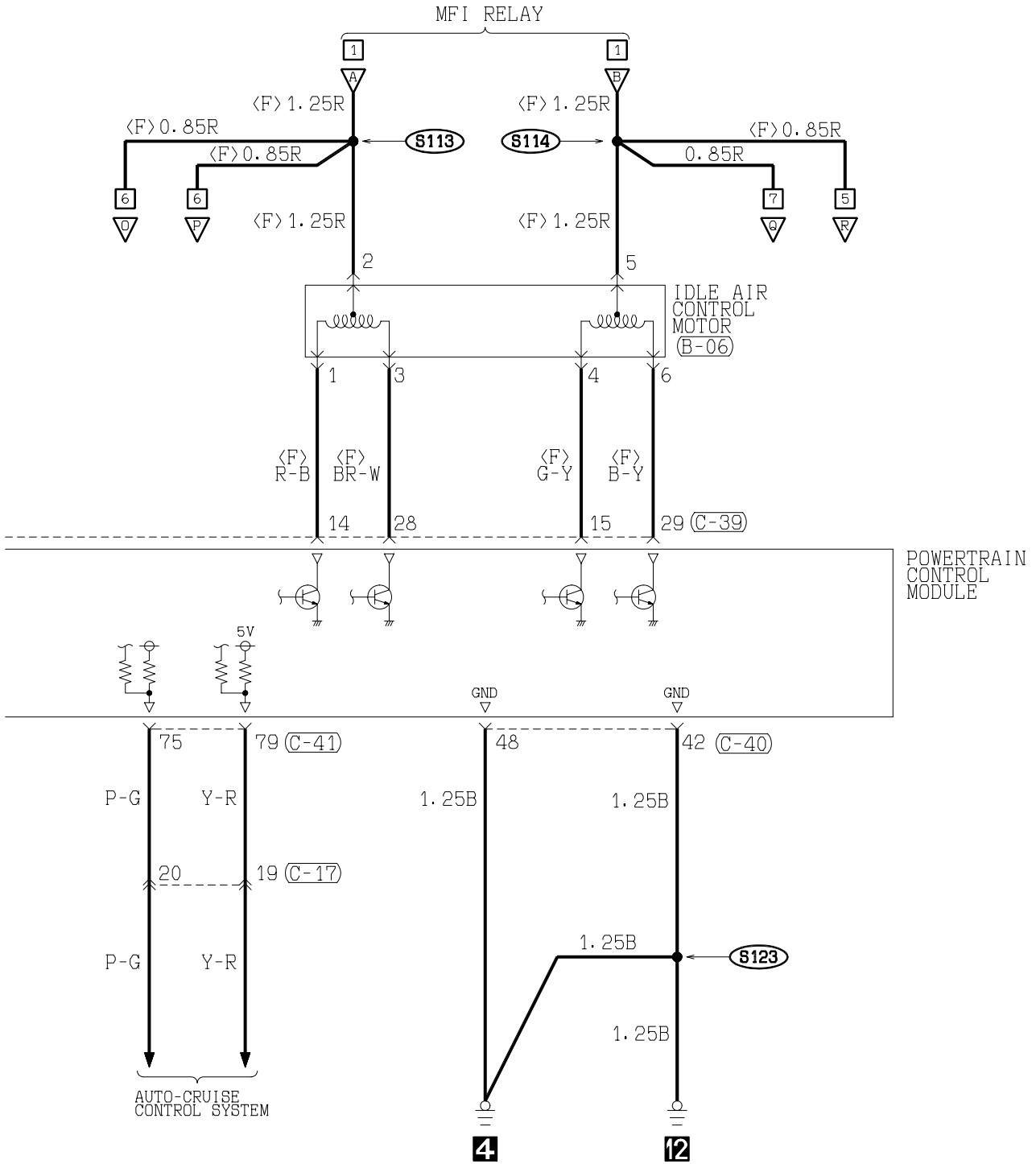

(C-40) (MU803781)

41	42	43		44	45	46
47	48	49	50	51	52	53
54	55	56	57	58	59	60
61	62	63	64	65	66	

(C-41) (MU803782)

71	72	73	74		75	76	77
78	79	80	81	82	83	84	85
86	87	88	89	90	91	92	93
94	95	96	97	98			

(C-71) MU801461

1	2	3	4	5	6	7	8	9	10
11	12	13	14	15	16	17	18	19	20
21	22								

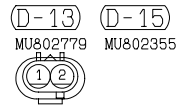

WIRE COLOR CODE
 B : BLACK BR : BROWN G : GREEN GR : GRAY L : BLUE LG : LIGHT GREEN O : ORANGE
 P : PINK R : RED SB : SKY BLUE V : VIOLET W : WHITE Y : YELLOW

H1F05M04DB

TSB Revision

MFI SYSTEM <2.4L ENGINE> (CONTINUED)

9

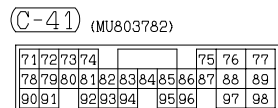
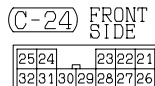
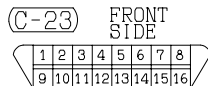
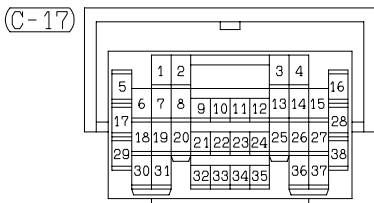
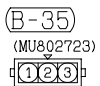
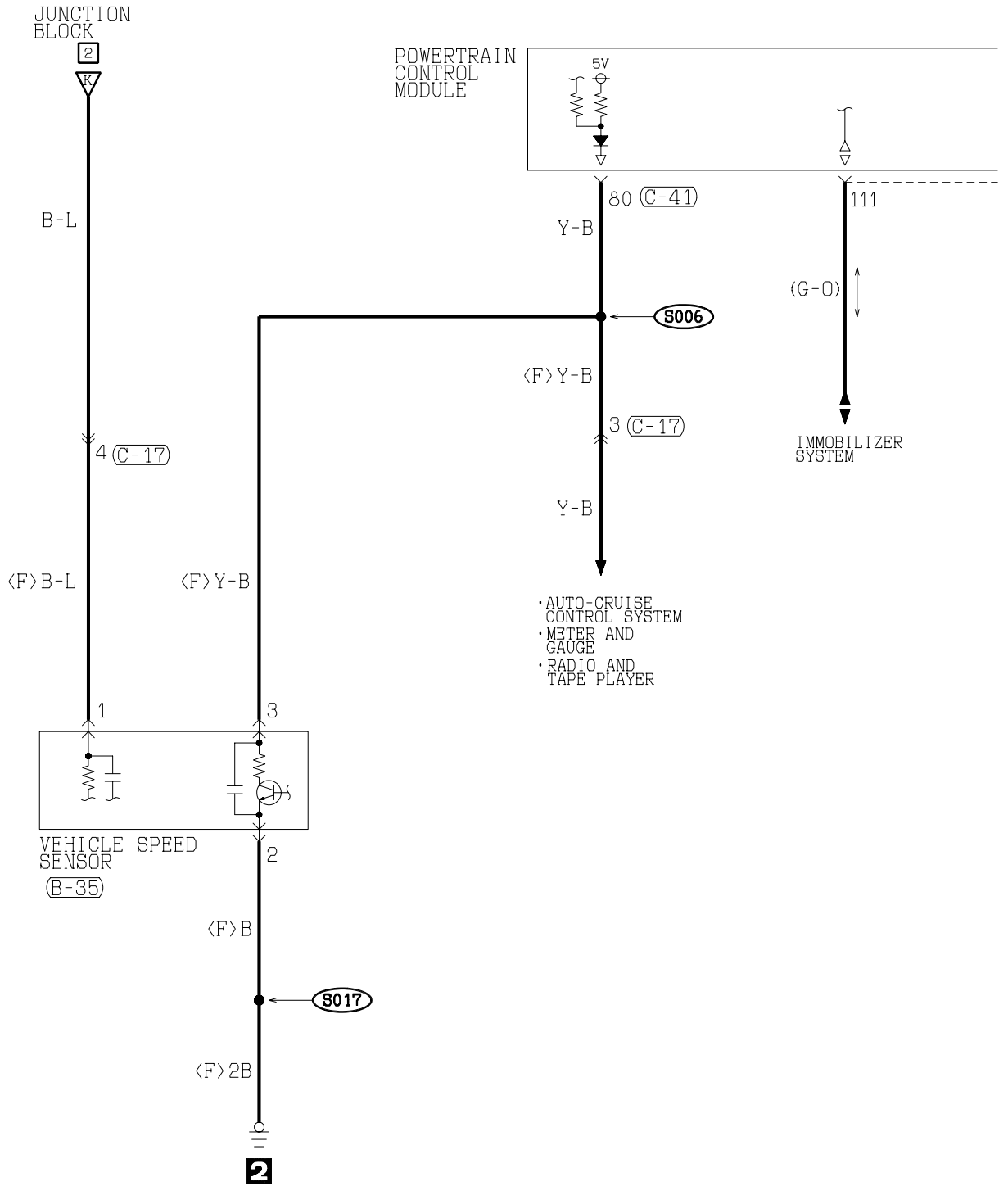

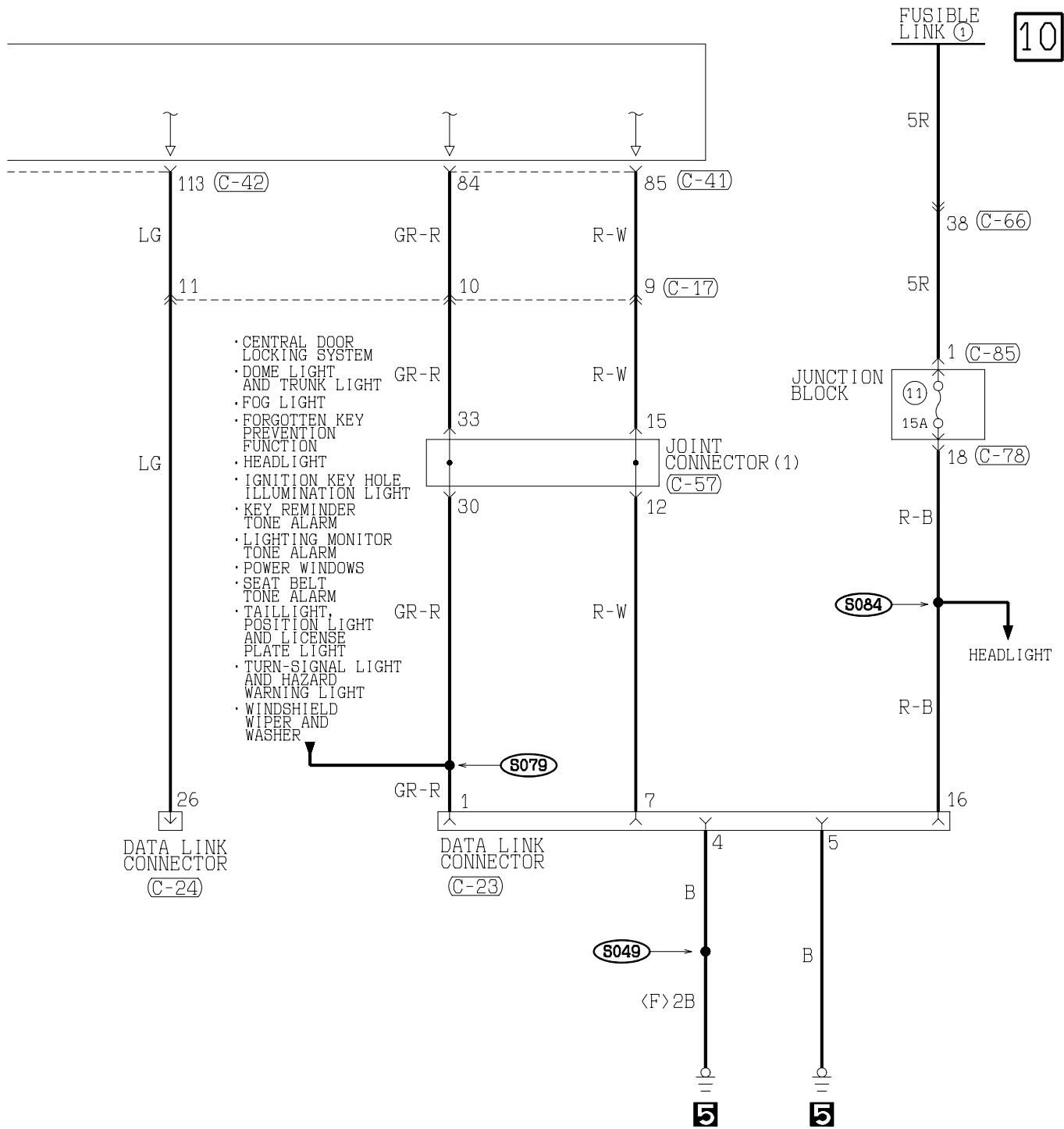

- CENTRAL DOOR LOCKING SYSTEM
- DOME LIGHT AND TRUNK LIGHT
- FOG LIGHT
- FORGOTTEN KEY PREVENTION FUNCTION
- HEADLIGHT
- IGNITION KEY HOLE ILLUMINATION LIGHT
- KEY REMINDER TONE ALARM
- LIGHTING MONITOR TONE ALARM
- POWER WINDOWS
- SEAT BELT TONE ALARM
- TAILLIGHT, POSITION LIGHT AND LICENSE PLATE LIGHT
- TURN-SIGNAL LIGHT AND HAZARD WARNING LIGHT
- WINDSHIELD WIPER AND WASHER

(C-42) (MU803783)

101	102	103	104	105	106	107
108	109	110	111	112	113	114
115	116	117	118	119	120	
121	122	123	124	125	126	127
128	129	130				

(C-57)

1	2	3	4	5	6	7	8	9	10	11
12	13	14	15	16	17	18	19	20	21	22
23	24	25	26	27	28	29	30	31	32	33

(C-66)

1	2	3	4	5	6	7	8	9	10	11	12	13
14	15	16	17	18	19	20	21	22	23	24	25	
26	27	28	29			30	31			38		
32	33	34		35		36	37					

(C-78) MU801457

1	2	3	4	5	6	7	8	9
10	11	12	13	14	15	16	17	18
19	20							

(C-85)

1

WIRE COLOR CODE
 B : BLACK BR : BROWN G : GREEN GR : GRAY L : BLUE LG : LIGHT GREEN O : ORANGE
 P : PINK R : RED SB : SKY BLUE V : VIOLET W : WHITE Y : YELLOW

H1S05M04EB

TSB Revision

MFI SYSTEM <3.0L ENGINE>

M1901000800093

1

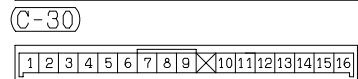
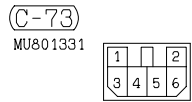
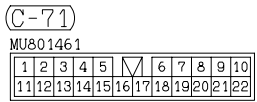
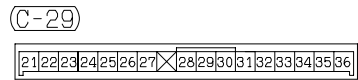
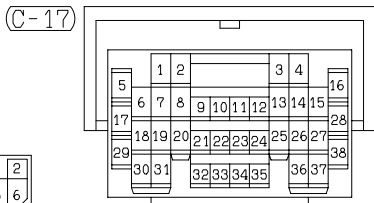
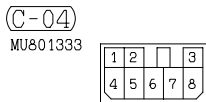
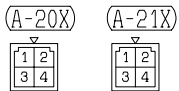
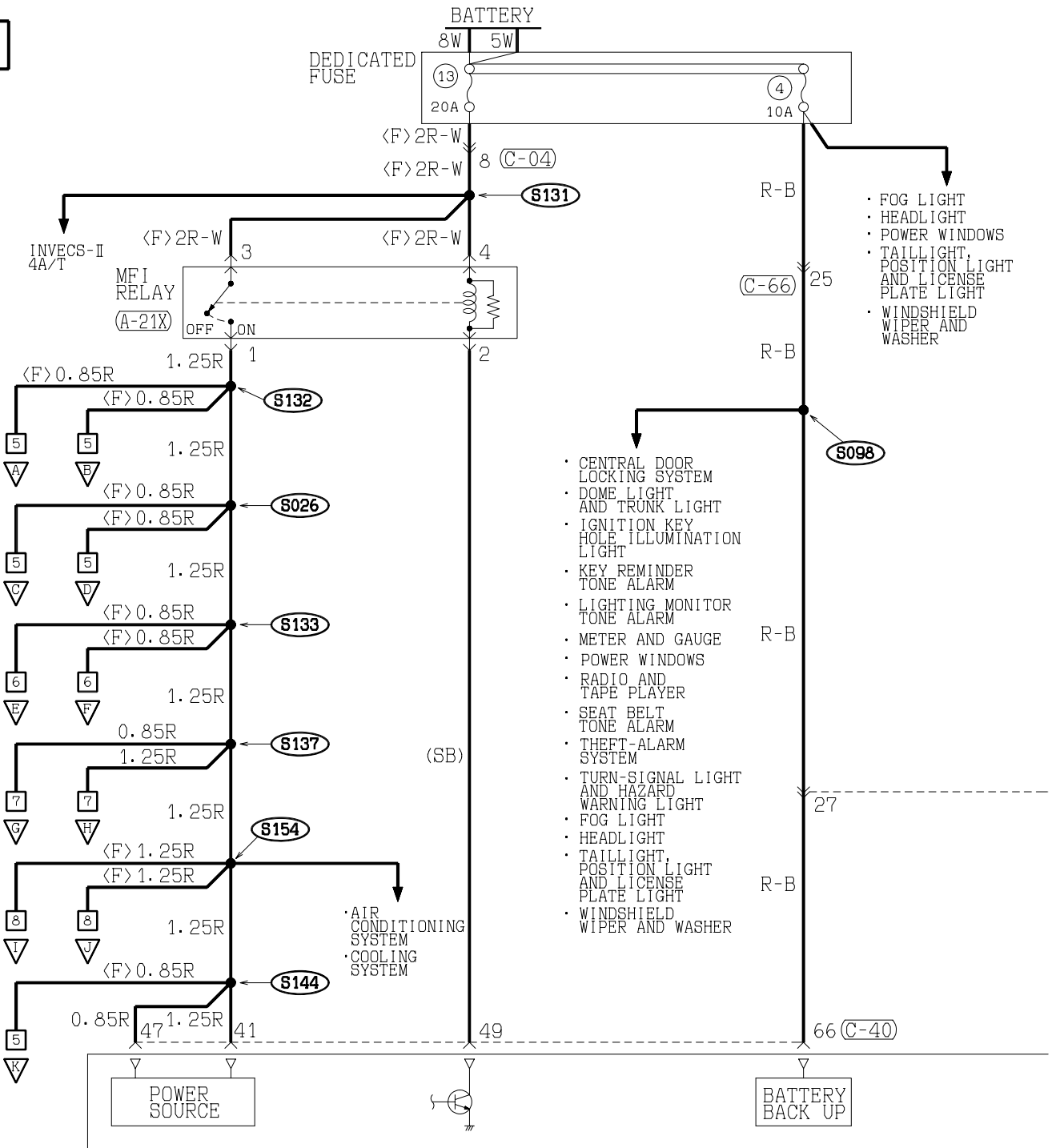

H1S05M05AA

TSB Revision

2

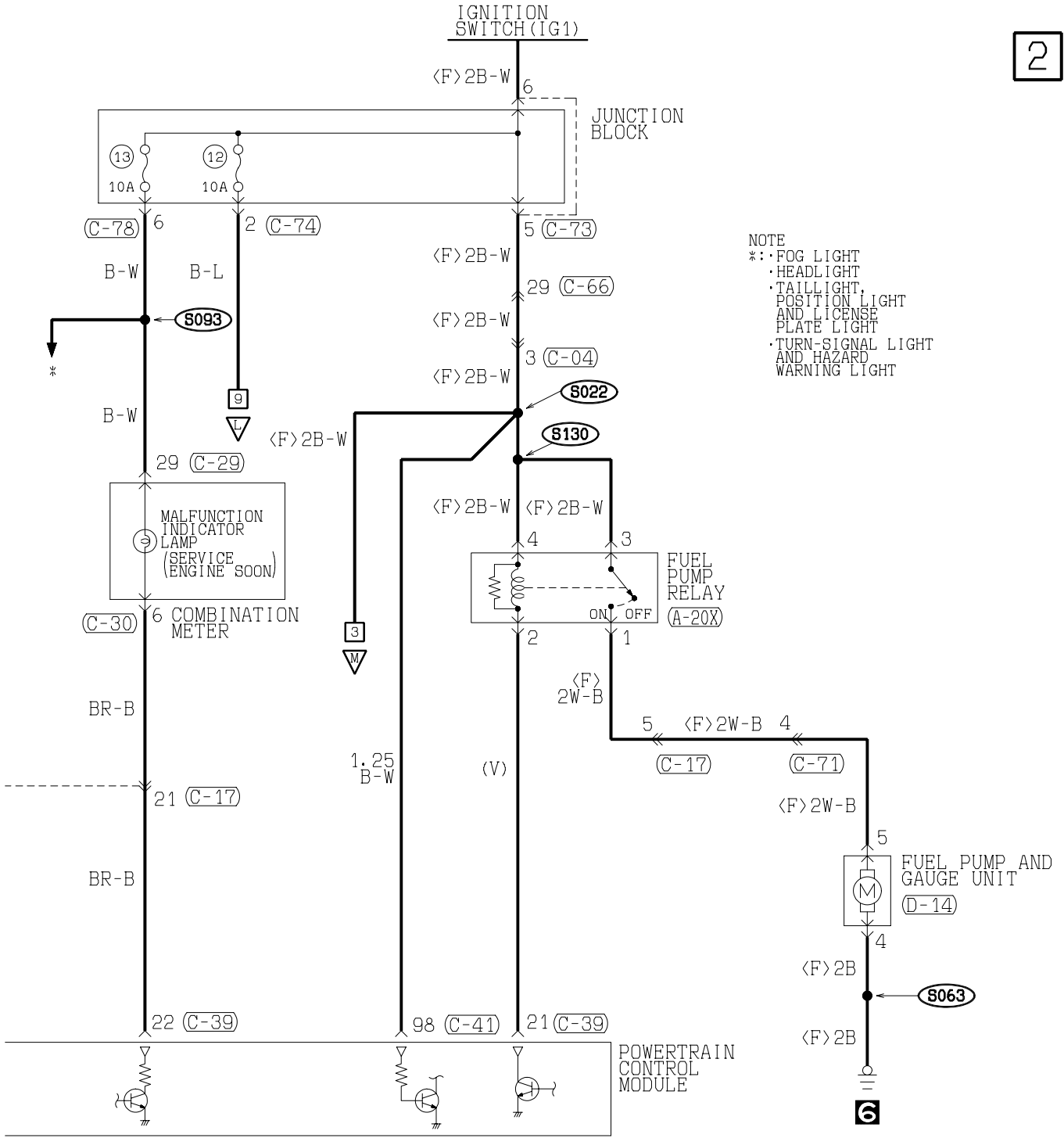

NOTE
* : FOG LIGHT
· HEADLIGHT
· TAILLIGHT
· POSITION LIGHT
AND LICENSE
PLATE LIGHT
· TURN-SIGNAL LIGHT
AND HAZARD
WARNING LIGHT

(C-39) (MU803784)

1	2	3	4	5	6	7	8							
9	10	11	12	13	14	15	16	17	18	19	20	21	22	23
24	25	26	27	28	29	30	31	32	33	34	35			

(C-40) (MU803781)

41	42	43	44	45	46					
47	48	49	50	51	52	53	54	55	56	57
58	59	60	61	62	63	64	65	66		

(C-41) (MU803782)

71	72	73	74	75	76	77					
78	79	80	81	82	83	84	85	86	87	88	89
90	91	92	93	94	95	96	97	98			

(C-66)

1	2	3	4	5	6	7	8	9	10	11	12	13
14	15	16	17	18	19	20	21	22	23	24	25	
26	27	28	29	30	31	38						
32	33	34	35	36	37							

(C-74)

1	2	3	4		
5	6	7	8	9	10

(C-78)

1	2	3	4	5	6	7	8	9		
10	11	12	13	14	15	16	17	18	19	20

(D-14)

1	2	3
4	5	

WIRE COLOR CODE

B : BLACK BR : BROWN
L : BLUE LG : LIGHT GREEN
R : RED SB : SKY BLUE
Y : YELLOW

G : GREEN GR : GRAY
O : ORANGE P : PINK
V : VIOLET W : WHITE

H1S05M05AB

TSB Revision

MFI SYSTEM <3.0L ENGINE> (CONTINUED)

3

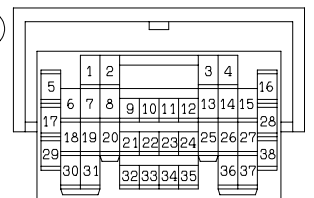
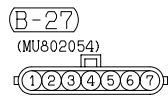
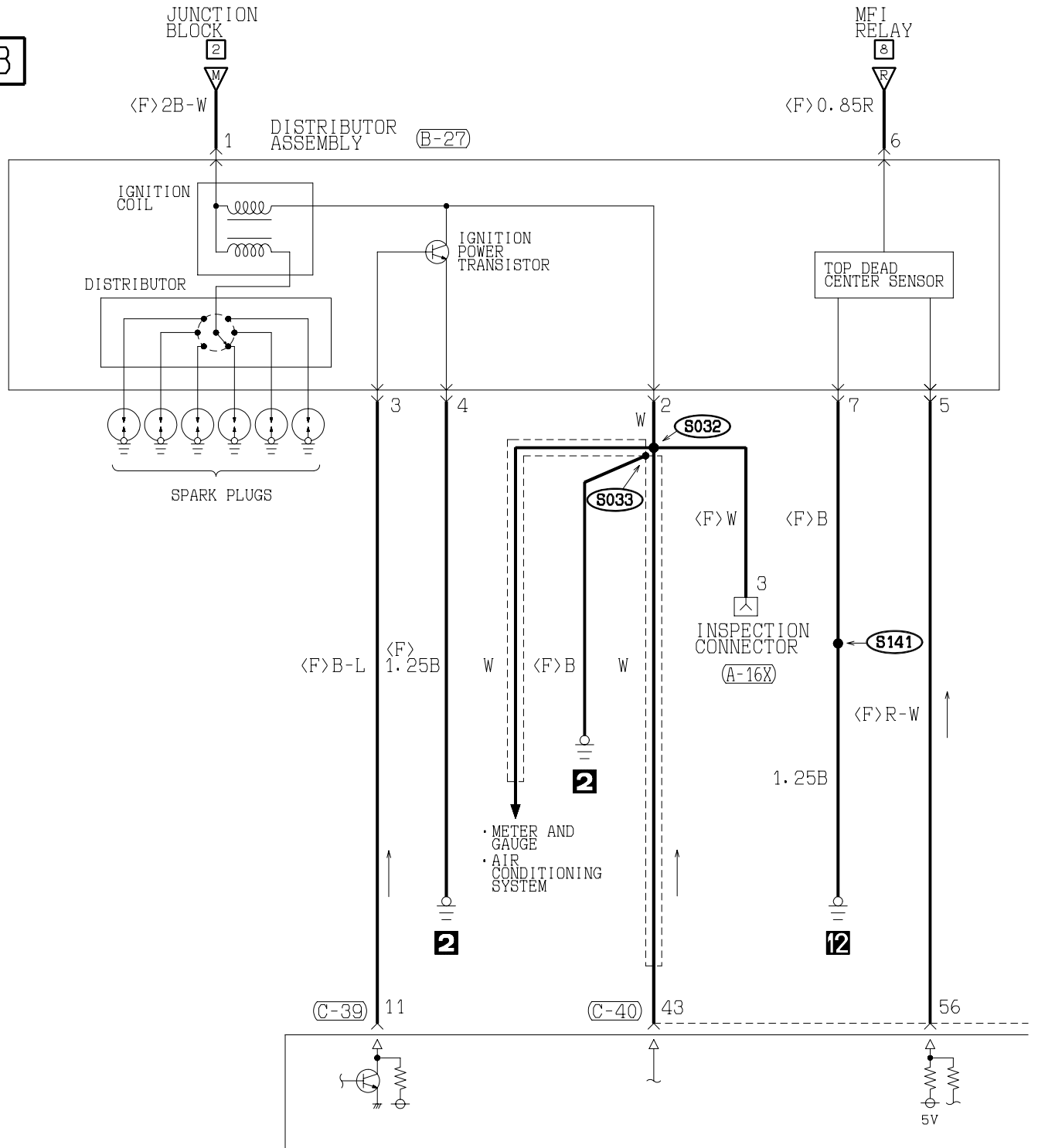

H1S05M05BA

TSB Revision

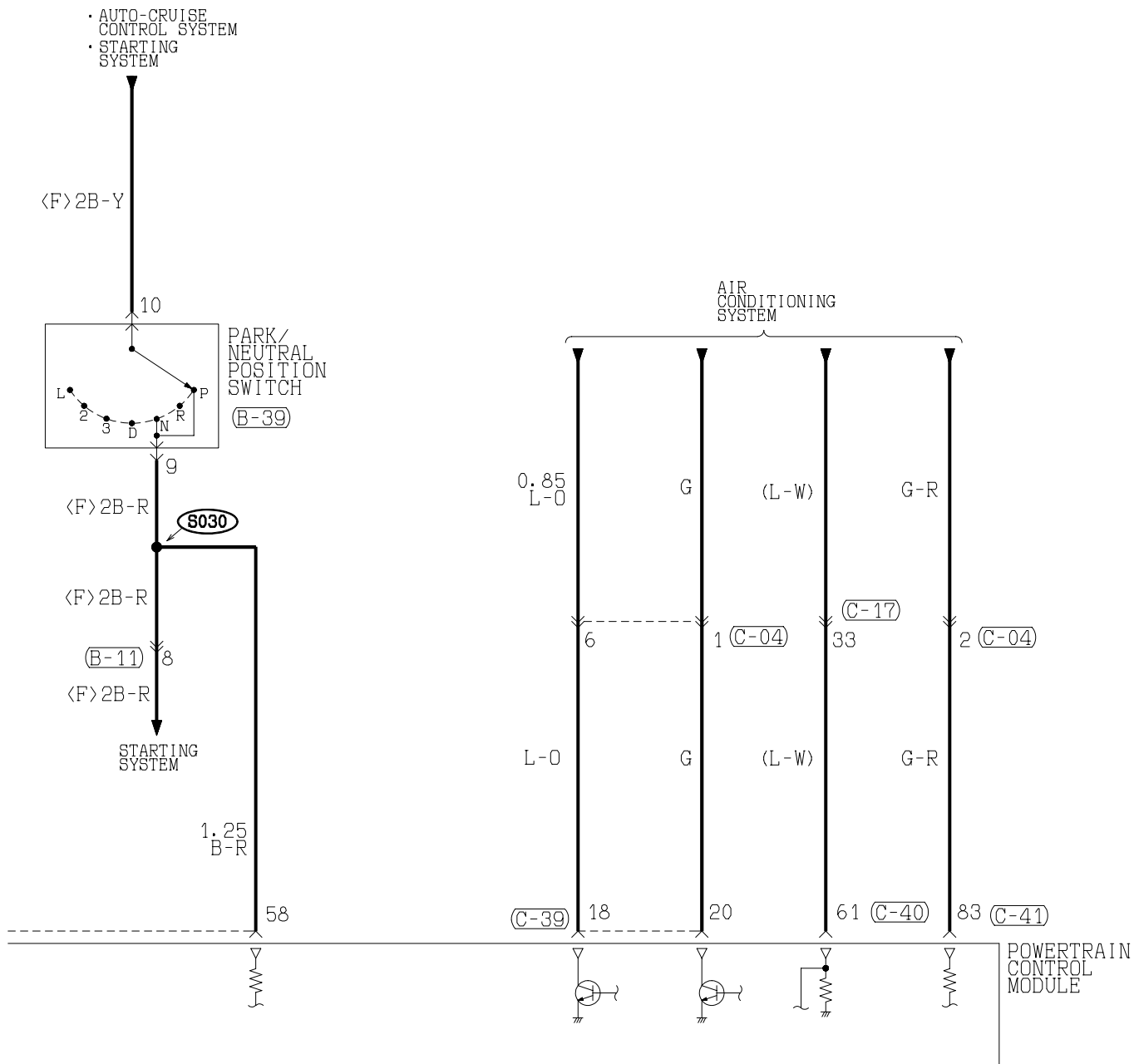

(C-39) (MU803784)

1	2	3	4	5	6	7	8							
9	10	11	12	13	14	15	16	17	18	19	20	21	22	23
24	25	26	27	28	29	30	31	32	33	34	35			

(C-40) (MU803781)

41	42	43	44	45	46					
47	48	49	50	51	52	53	54	55	56	57
58	59	60	61	62	63	64	65	66		

(C-41) (MU803782)

71	72	73	74	75	76	77					
78	79	80	81	82	83	84	85	86	87	88	89
90	91	92	93	94	95	96	97	98			

WIRE COLOR CODE

B : BLACK BR : BROWN
P : PINK R : RED

G : GREEN
SB : SKY BLUE

GR : GRAY
V : VIOLET

L : BLUE
W : WHITE

LG : LIGHT GREEN
Y : YELLOW

O : ORANGE

H1S05M05BB

MFI SYSTEM <3.0L ENGINE> (CONTINUED)

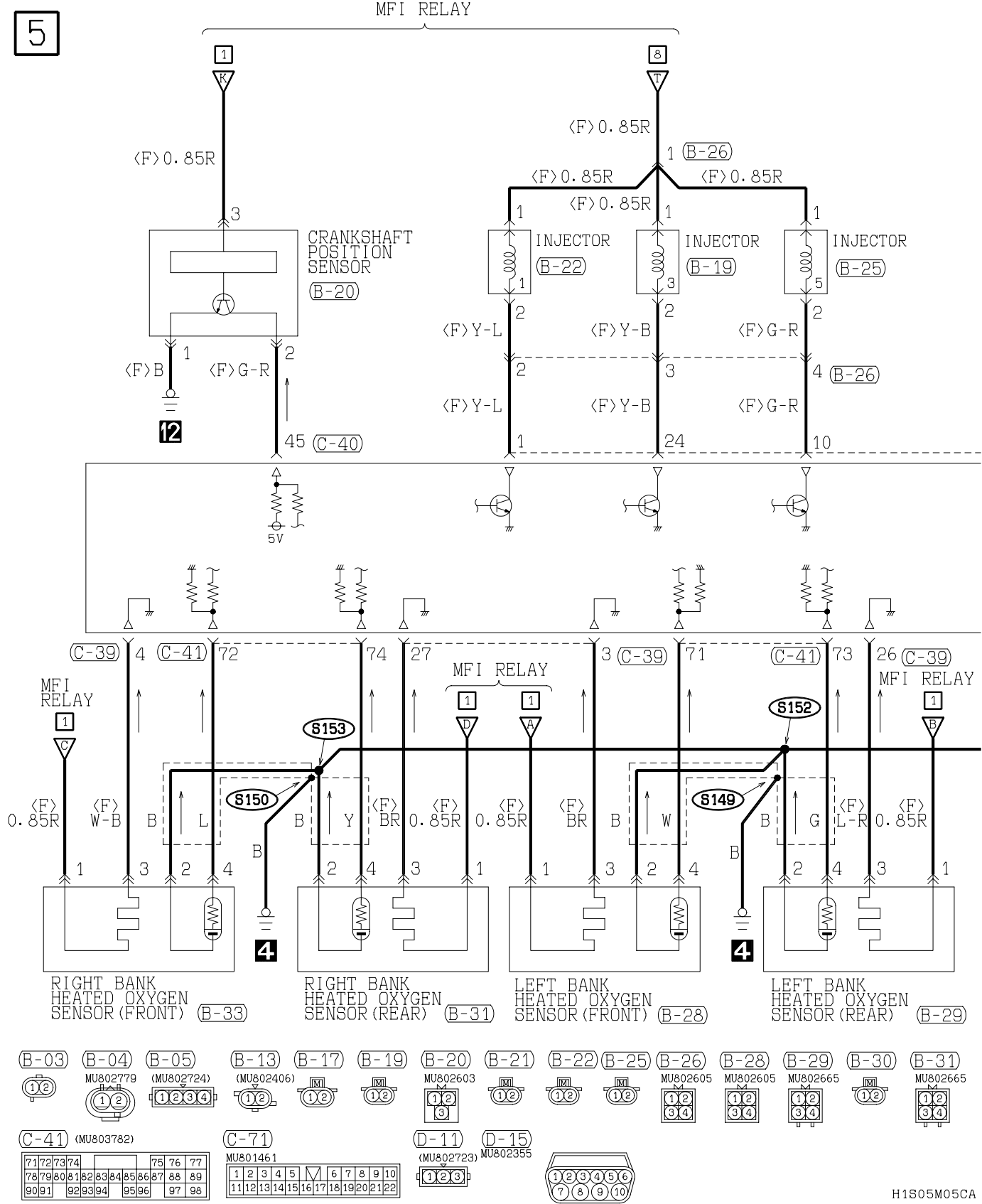

H1S05M05CA

TSB Revision

6

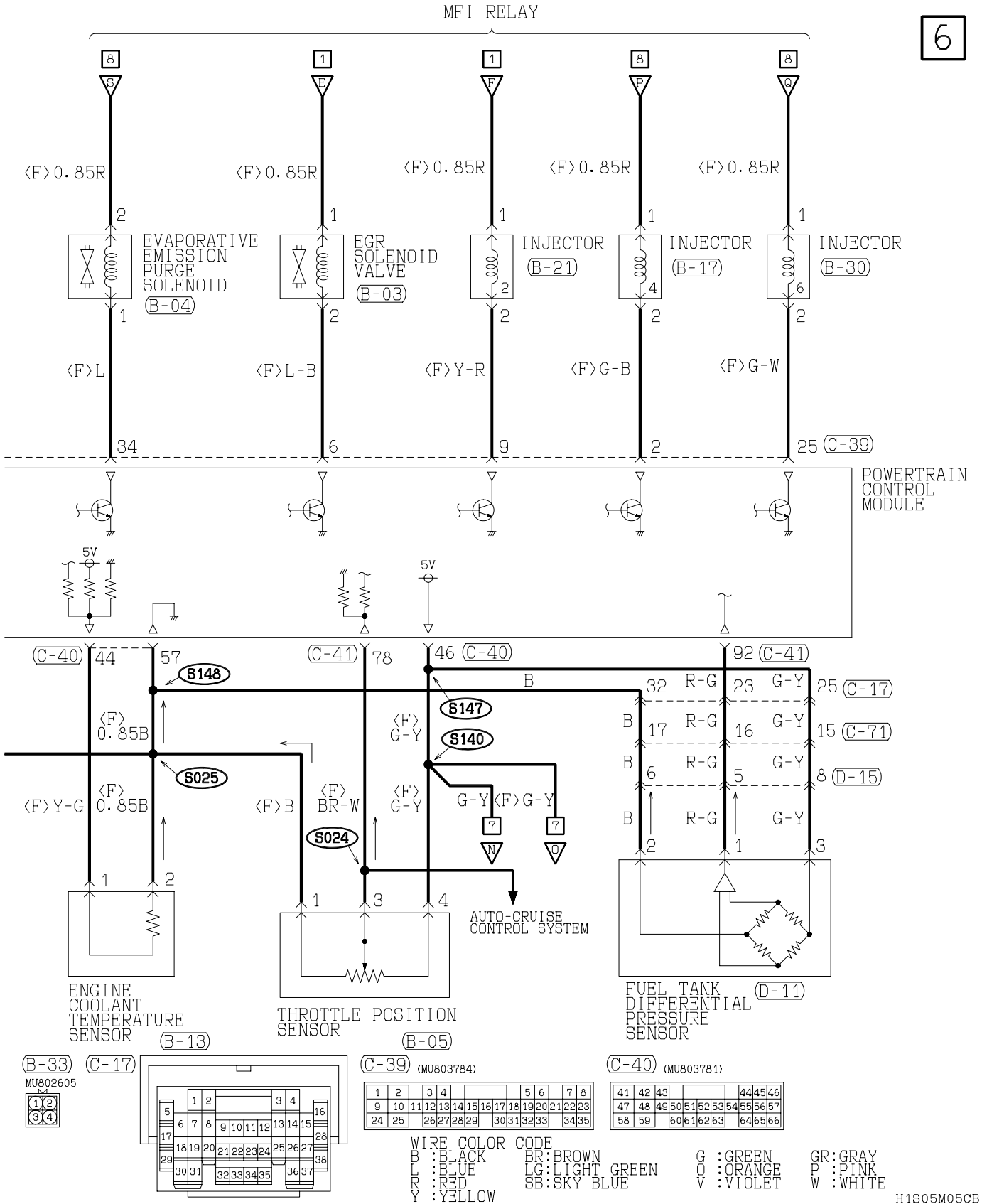

TSB Revision

MFI SYSTEM <3.0L ENGINE> (CONTINUED)

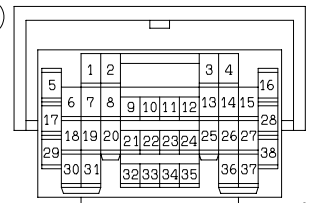
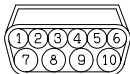
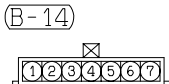
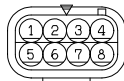
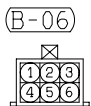
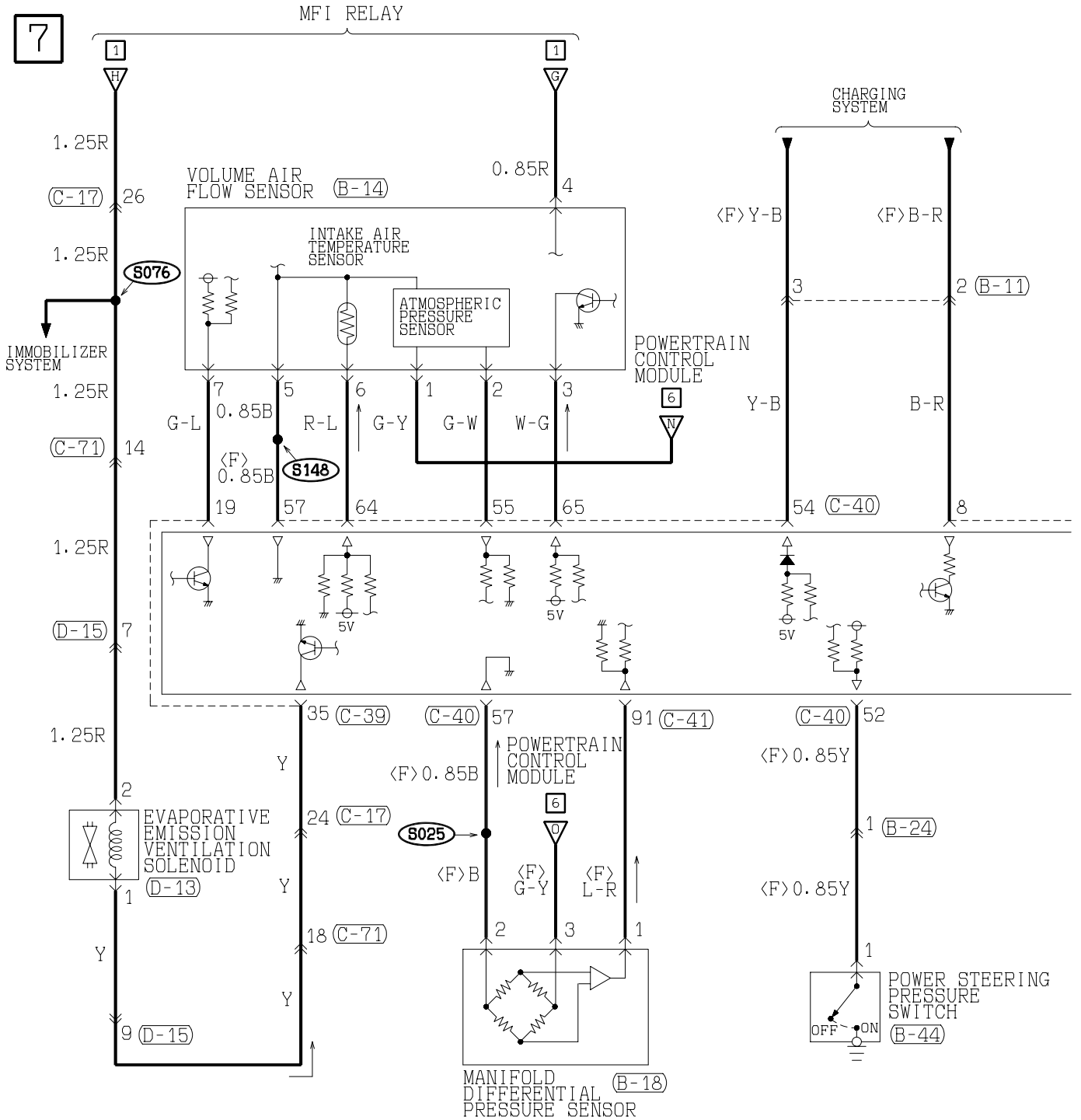

H1S05M05DA

8

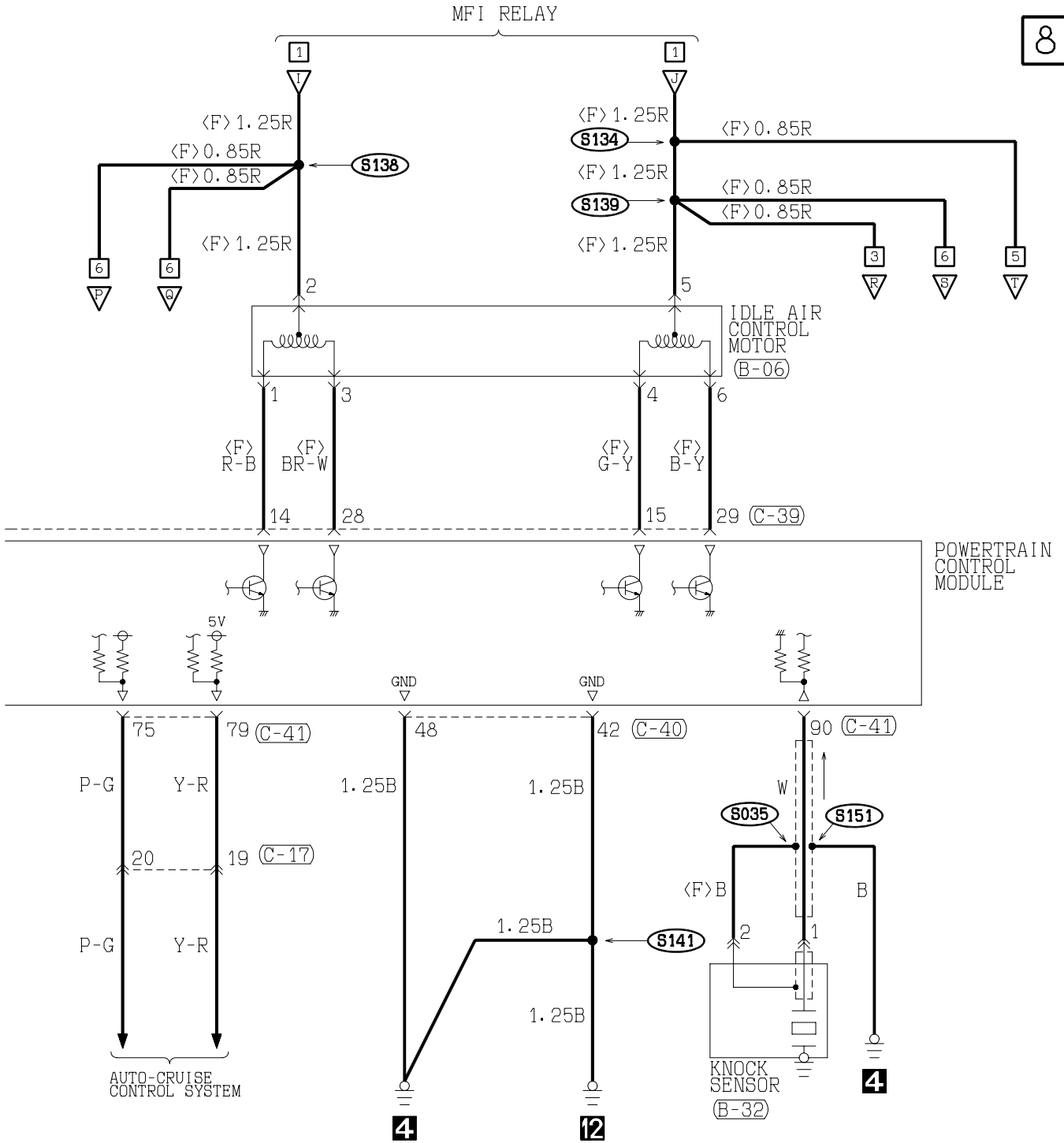

(C-39) (MU803784)

1	2	3	4	5	6	7	8							
9	10	11	12	13	14	15	16	17	18	19	20	21	22	23
24	25	26	27	28	29	30	31	32	33	34	35			

(C-40) (MU803781)

41	42	43		44	45	46				
47	48	49	50	51	52	53	54	55	56	57
58	59	60	61	62	63	64	65	66		

(C-41) (MU803782)

71	72	73	74		75	76	77				
78	79	80	81	82	83	84	85	86	87	88	89
90	91	92	93	94	95	96	97	98			

(C-71)

MU801461											
1	2	3	4	5	6	7	8	9	10		
11	12	13	14	15	16	17	18	19	20	21	22

(D-13)

MU802779	
1	2

WIRE COLOR CODE
 B : BLACK BR : BROWN G : GREEN GR : GRAY L : BLUE LG : LIGHT GREEN O : ORANGE
 P : PINK R : RED SB : SKY BLUE V : VIOLET W : WHITE Y : YELLOW

H1S05M05DB

TSB Revision

MFI SYSTEM <3.0L ENGINE> (CONTINUED)

9

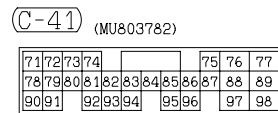
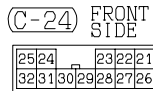
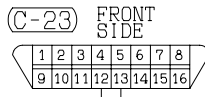
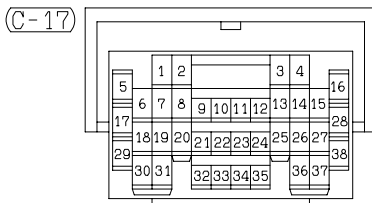
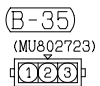
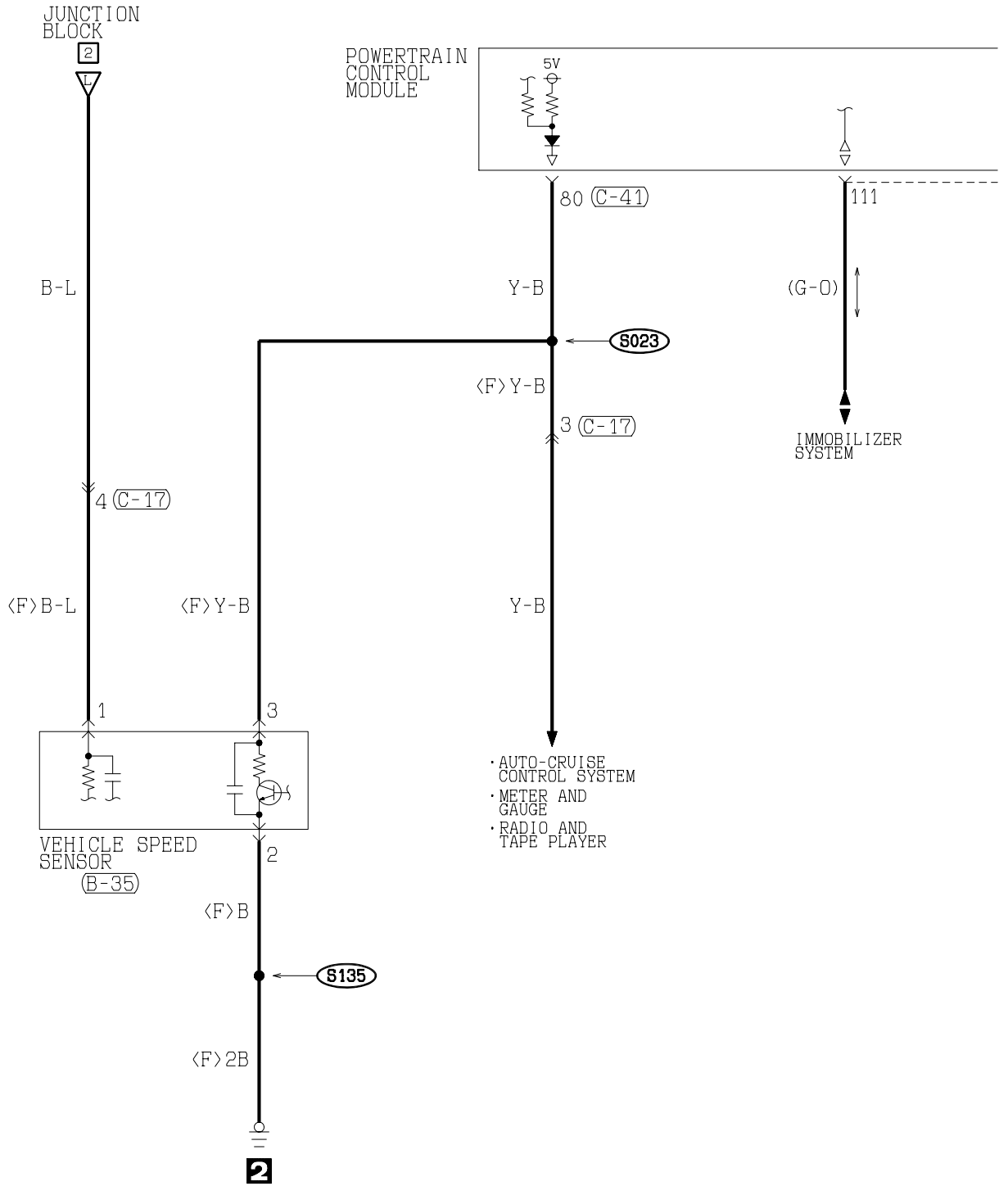

H1S05M05EA

TSB Revision

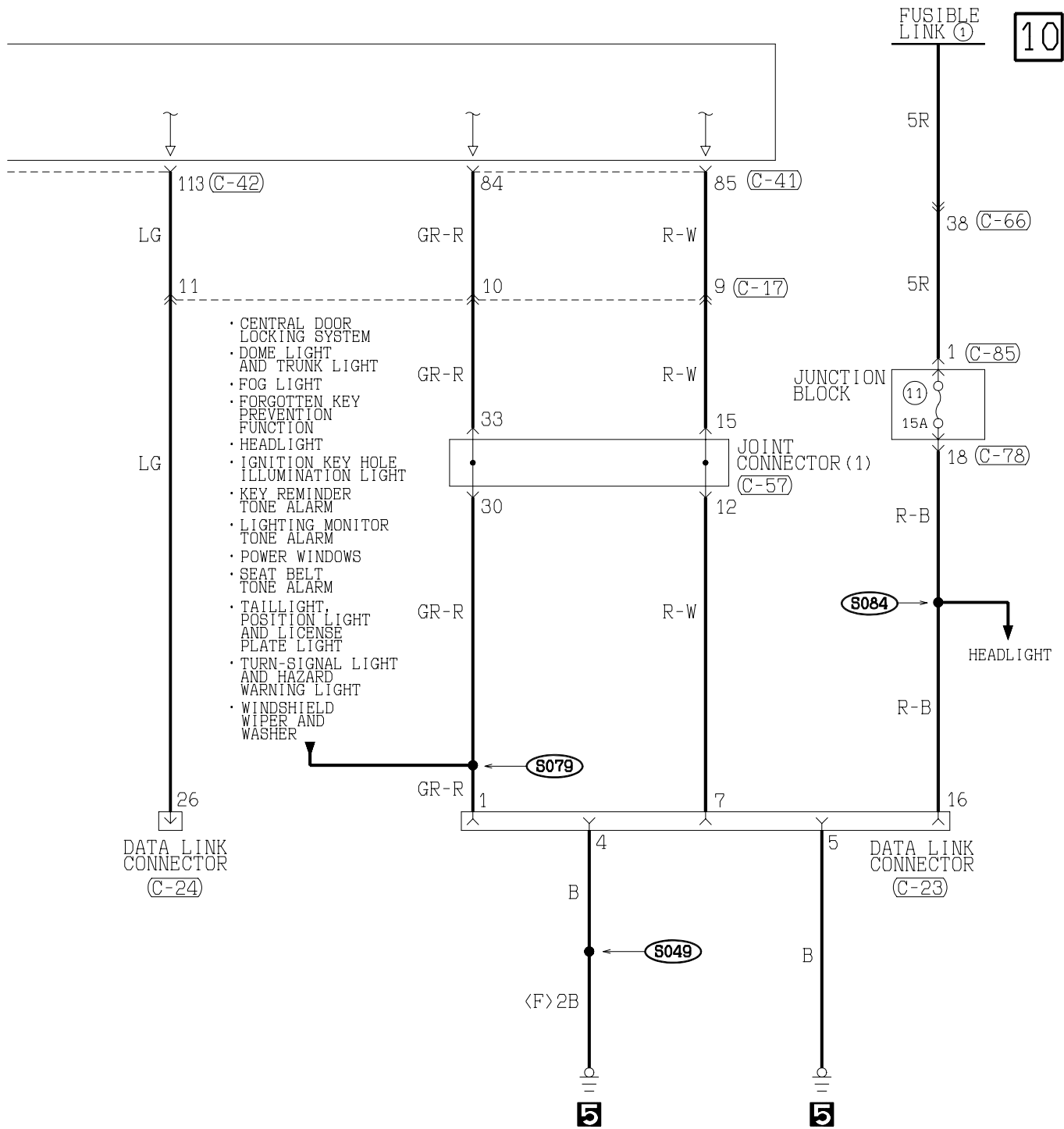

(C-42) (MU803783)

101	102	103	104	105	106	107
108	109	110	111	112	113	114
115	116	117	118	119	120	121
122	123	124	125	126	127	128
129	130					

(C-57)

1	2	3	4	5	6	7	8	9	10	11
12	13	14	15	16	17	18	19	20	21	22
23	24	25	26	27	28	29	30	31	32	33

(C-66)

1	2	3	4	5	6	7	8	9	10	11	12	13
14	15	16	17	18	19	20	21	22	23	24	25	38
26	27	28	29				30	31				
32	33	34		35			36	37				

(C-78) MU801457

1	2	3	4	5	6	7	8	9
10	11	12	13	14	15	16	17	18
19	20							

(C-85)

1

WIRE COLOR CODE
 B : BLACK BR : BROWN G : GREEN GR : GRAY L : BLUE LG : LIGHT GREEN O : ORANGE
 P : PINK R : RED SB : SKY BLUE V : VIOLET W : WHITE Y : YELLOW

H1S05M05EB

TSB Revision

COOLING SYSTEM

M1901001000045

1

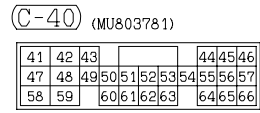
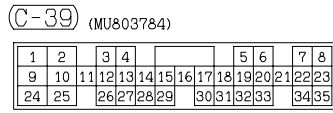
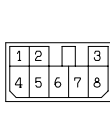
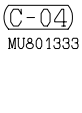
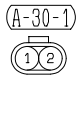
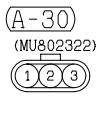
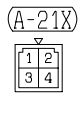
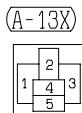
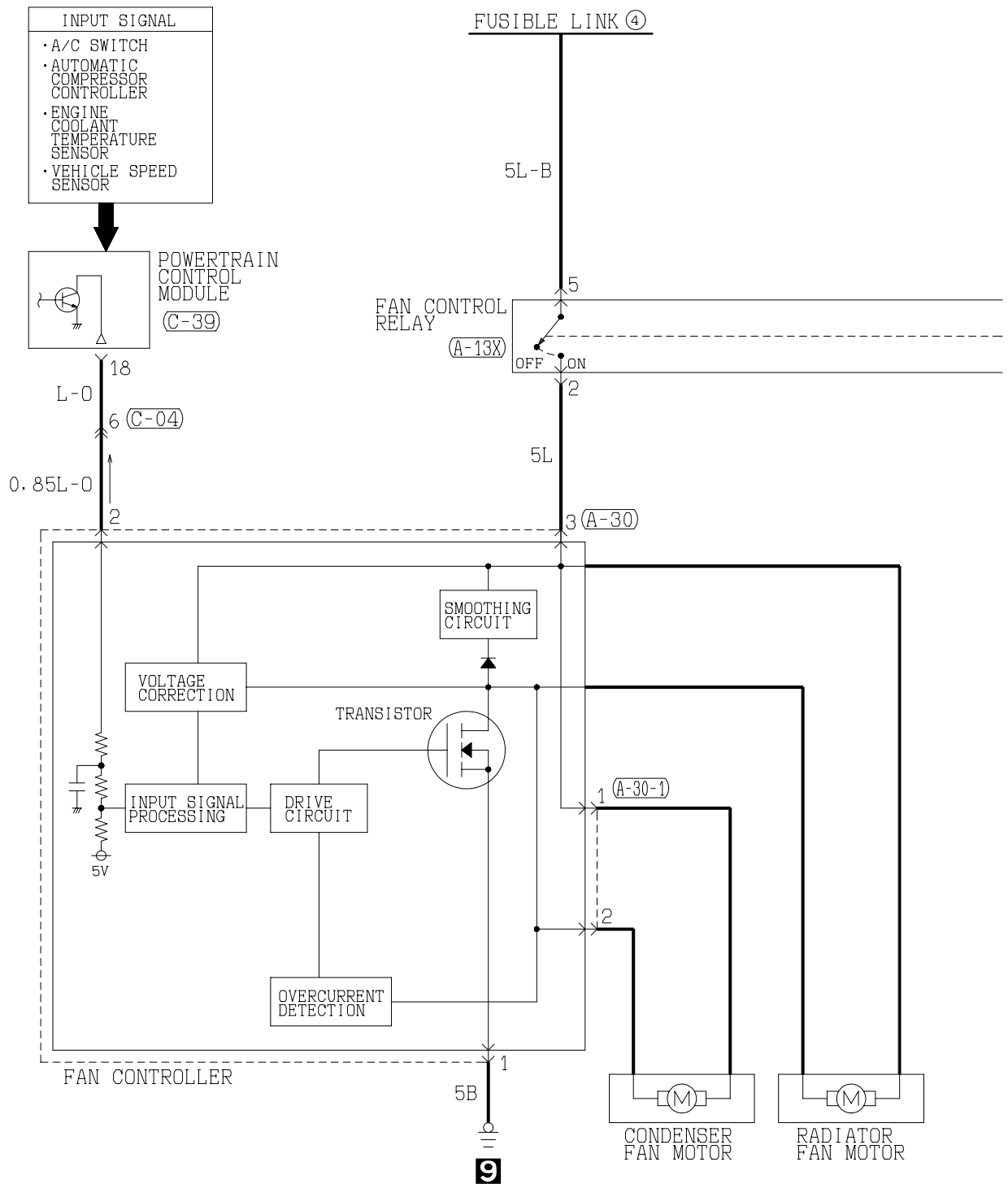

H1S06M02AA

TSB Revision

2

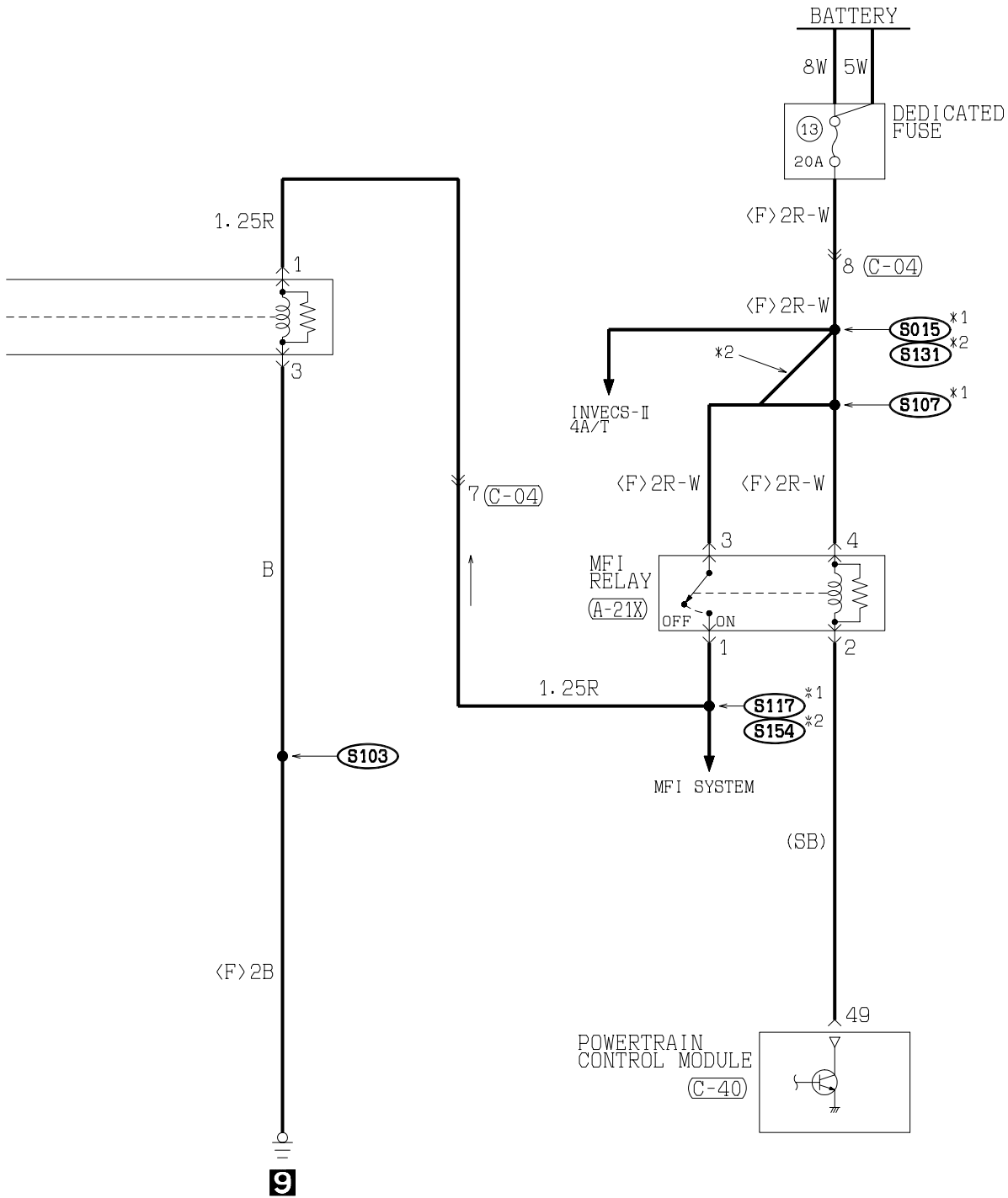

NOTE
*1:2.4L ENGINE
*2:3.0L ENGINE

WIRE COLOR CODE
B :BLACK BR: BROWN G :GREEN GR:GRAY L :BLUE LG: LIGHT GREEN O :ORANGE
P :PINK R :RED SB: SKY BLUE V :VIOLET W :WHITE Y :YELLOW

H1S06M02AB

TSB Revision

INVECS-II 4A/T

1

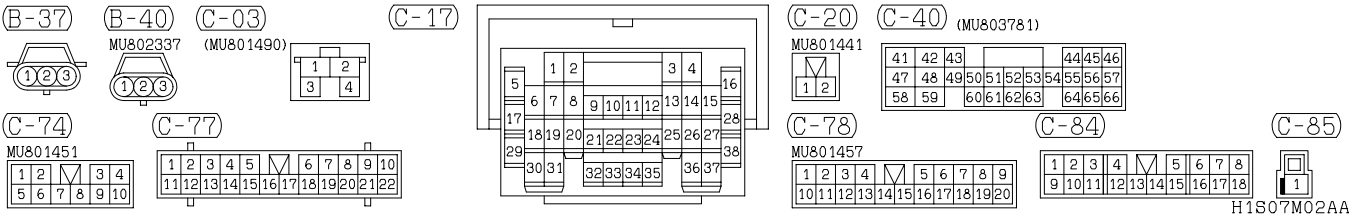
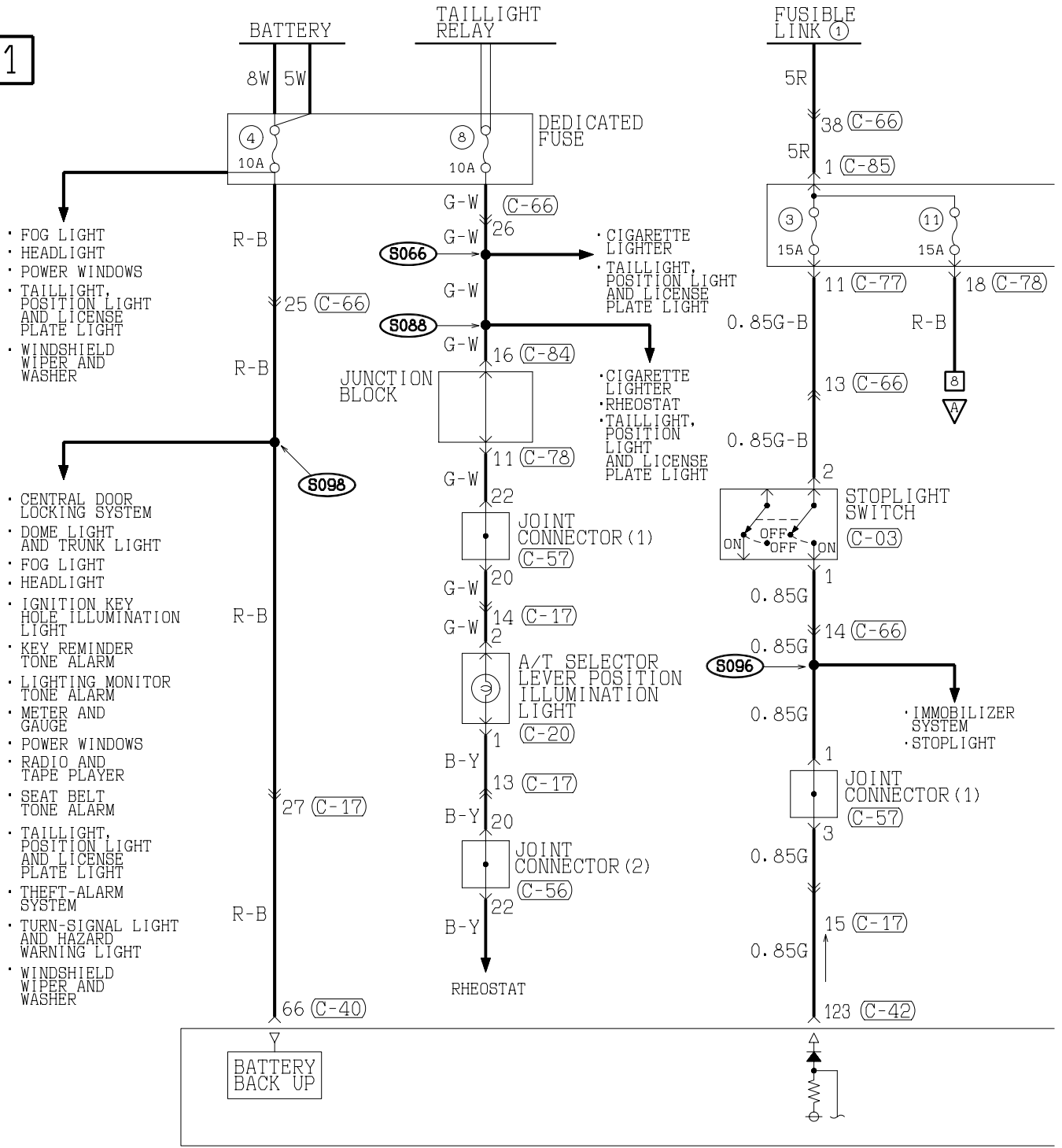

H1S07M02AA

TSB Revision

2

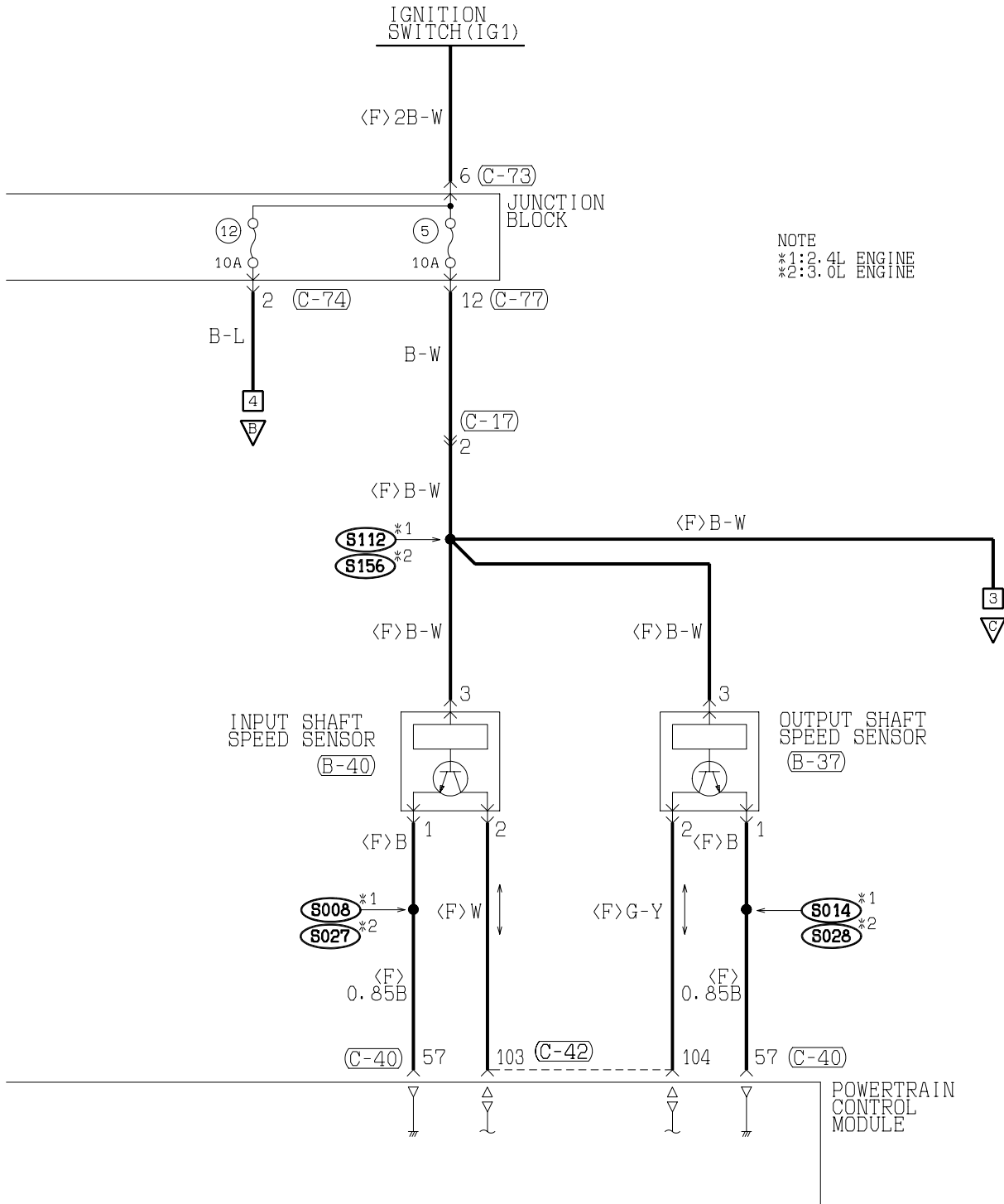

NOTE
*1: 2.4L ENGINE
*2: 3.0L ENGINE

(C-42) (MU803783)

101	102	103	104	105	106	107
108	109	110	111	112	113	114
115	116	117	118	119	120	121
122	123	124	125	126	127	128
129	130					

(C-56)

1	2	3	4	5	6	7	8	9	10	11
12	13	14	15	16	17	18	19	20	21	22
23	24	25	26	27	28	29	30	31	32	33

(C-57)

1	2	3	4	5	6	7	8	9	10	11
12	13	14	15	16	17	18	19	20	21	22
23	24	25	26	27	28	29	30	31	32	33

(C-66)

1	2	3	4	5	6	7	8	9	10	11	12	13
14	15	16	17	18	19	20	21	22	23	24	25	26
27	28	29	30	31	32	33	34	35	36	37	38	

(C-73) MU801331

1	2
3	4
5	6

TSB Revision

INVECS-II 4A/T (CONTINUED)

3

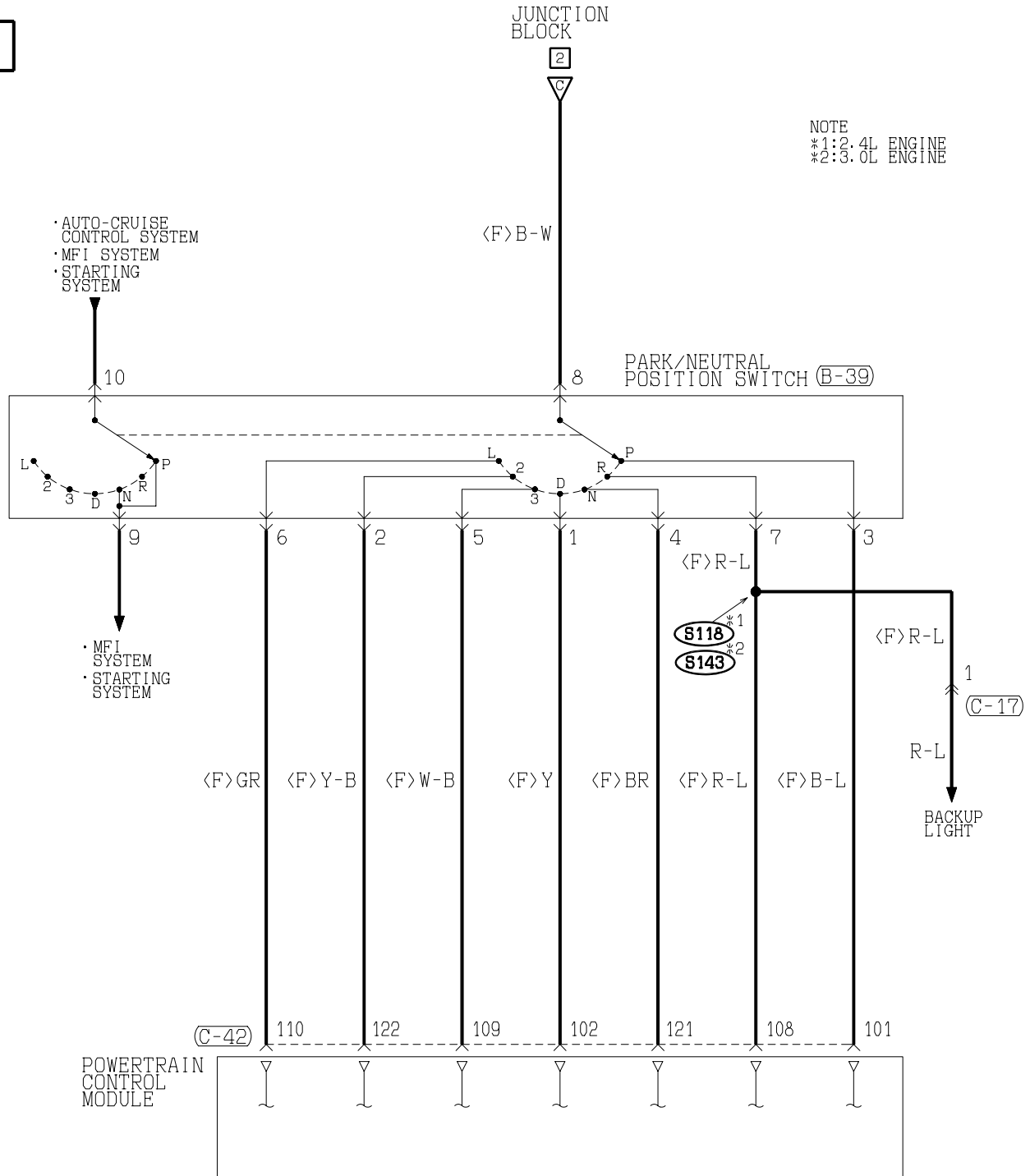

NOTE
*1: 2.4L ENGINE
*2: 3.0L ENGINE

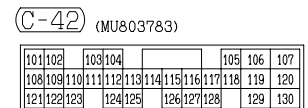
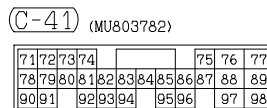
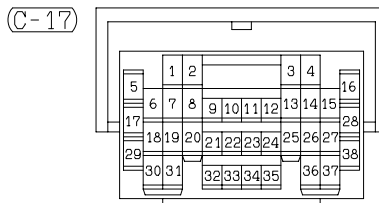
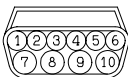
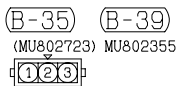

H1S07M02BA

TSB Revision

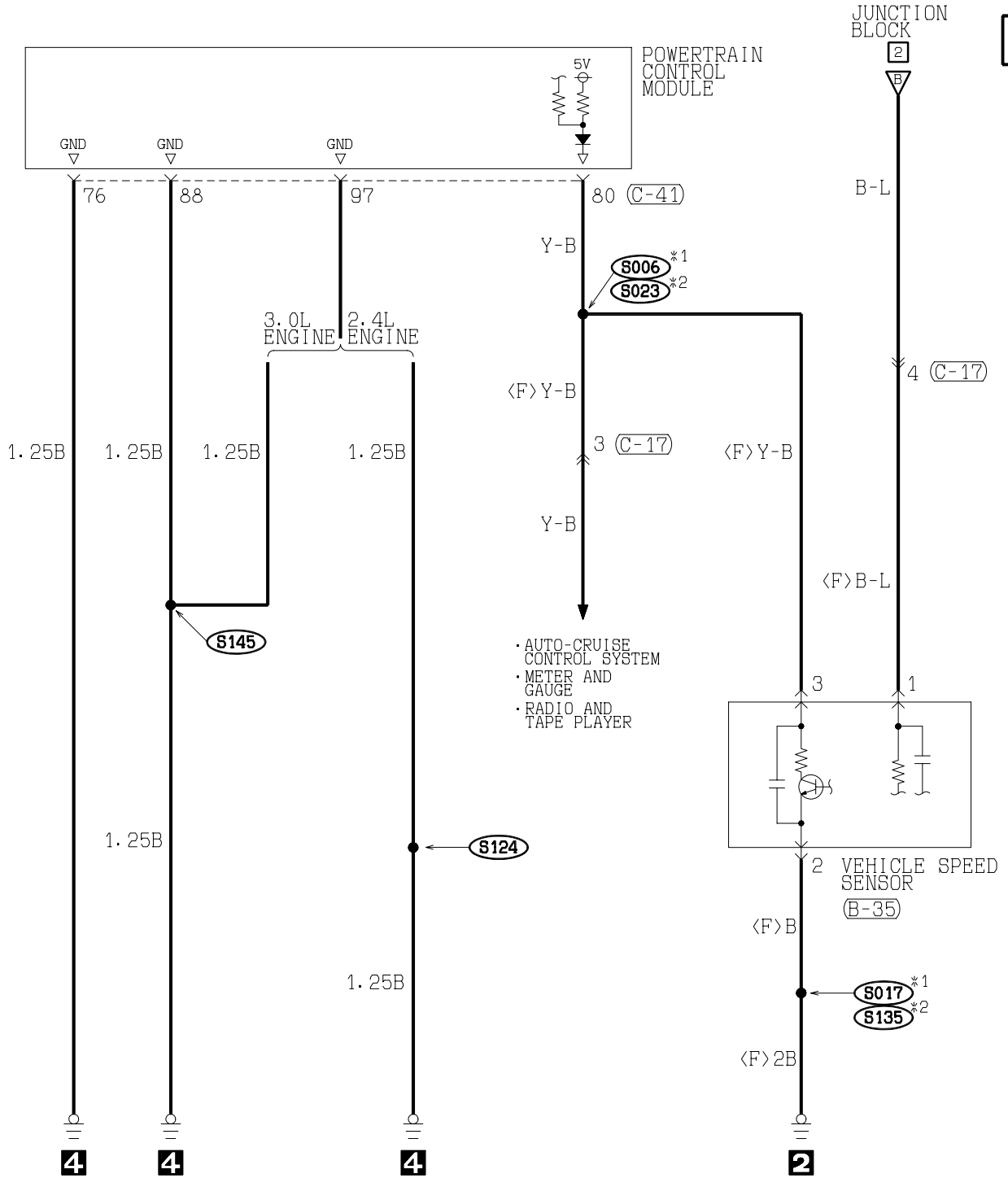

WIRE COLOR CODE		G : GREEN		GR : GRAY		L : BLUE		LG : LIGHT GREEN		O : ORANGE	
B : BLACK	BR : BROWN	SB : SKY BLUE	V : VIOLET	W : WHITE	Y : YELLOW						
P : PINK	R : RED										

H1507M02BB

TSB Revision

INVECS-II 4A/T (CONTINUED)

5

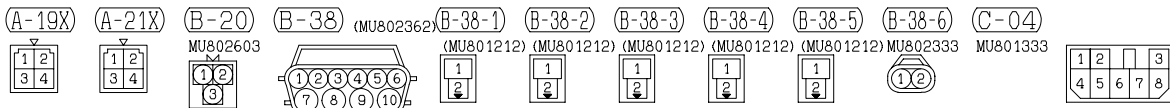
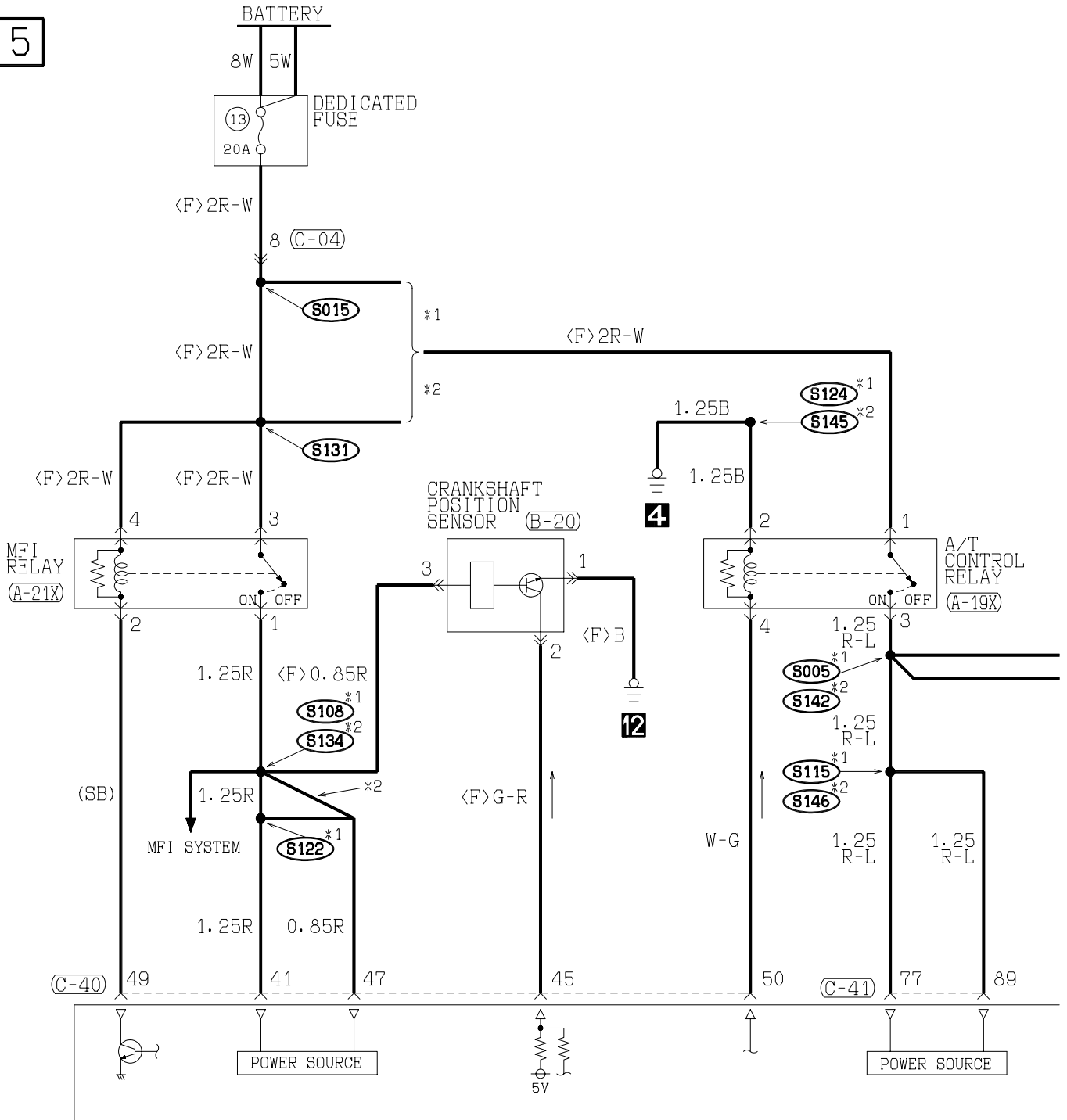

TSB Revision

6

- NOTE
- *1: 2.4L ENGINE
 - *2: 3.0L ENGINE
 - *3: UNDERDRIVE SOLENOID VALVE
 - *4: SECOND SOLENOID VALVE
 - *5: OVERDRIVE SOLENOID VALVE
 - *6: TORQUE CONVERTER CLUTCH CONTROL SOLENOID VALVE
 - *7: LOW AND REVERSE SOLENOID VALVE

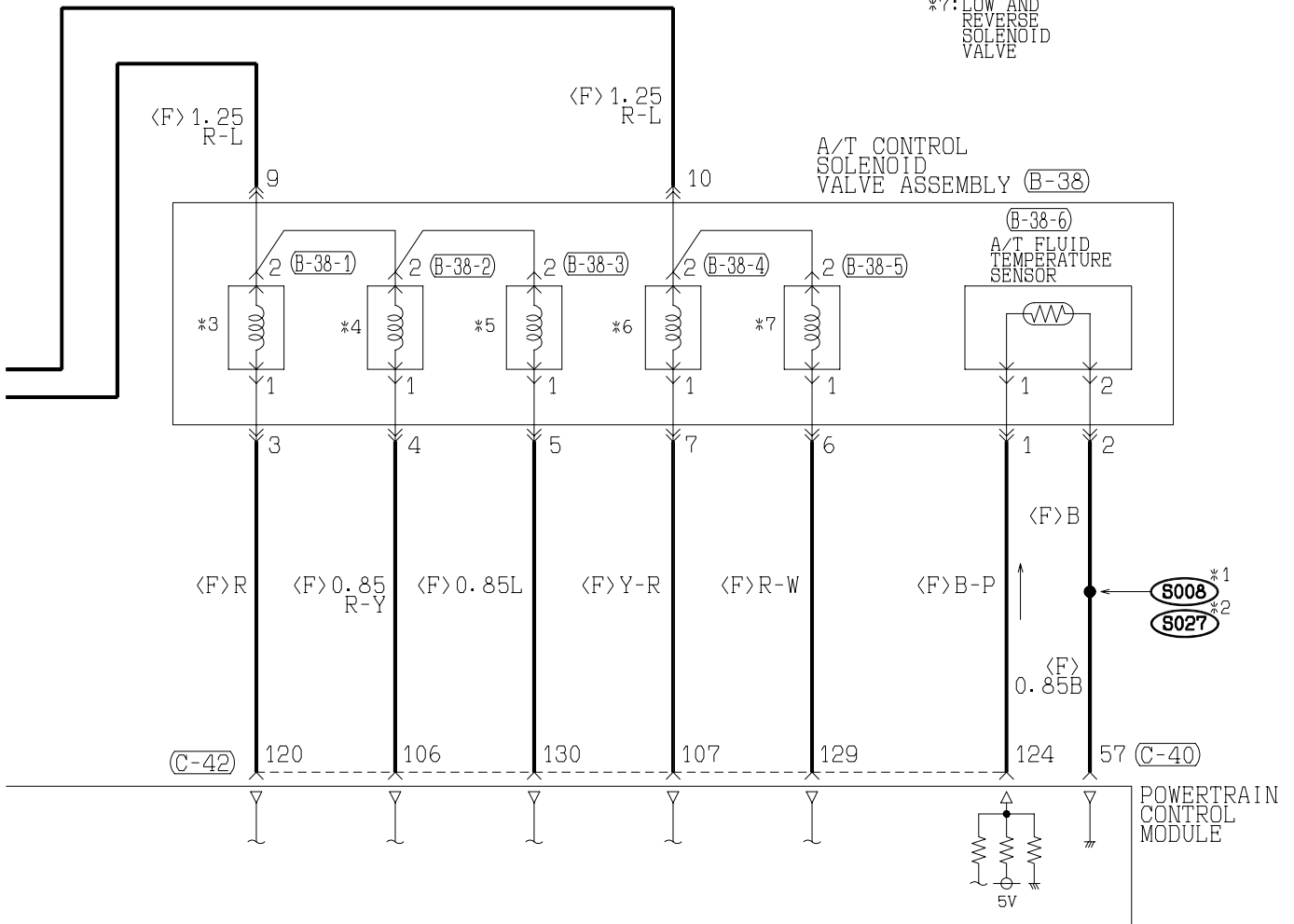

(C-40) (MU803781)

41	42	43		44	45	46				
47	48	49	50	51	52	53	54	55	56	57
58	59	60	61	62	63	64	65	66		

(C-41) (MU803782)

71	72	73	74			75	76	77			
78	79	80	81	82	83	84	85	86	87	88	89
90	91	92	93	94	95	96	97	98			

(C-42) (MU803783)

101	102		103	104			105	106	107			
108	109	110	111	112	113	114	115	116	117	118	119	120
121	122	123		124	125		126	127	128		129	130

WIRE COLOR CODE
 B : BLACK BR : BROWN G : GREEN GR : GRAY L : BLUE LG : LIGHT GREEN O : ORANGE
 P : PINK R : RED SB : SKY BLUE V : VIOLET W : WHITE Y : YELLOW

H1507M02CB

TSB Revision

INVECS-II 4A/T (CONTINUED)

7

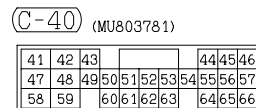
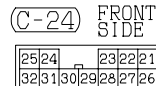
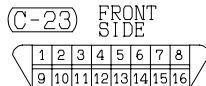
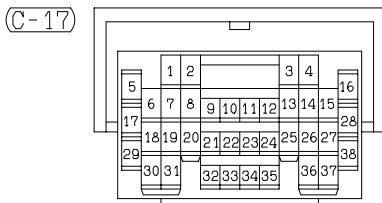
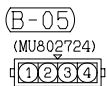
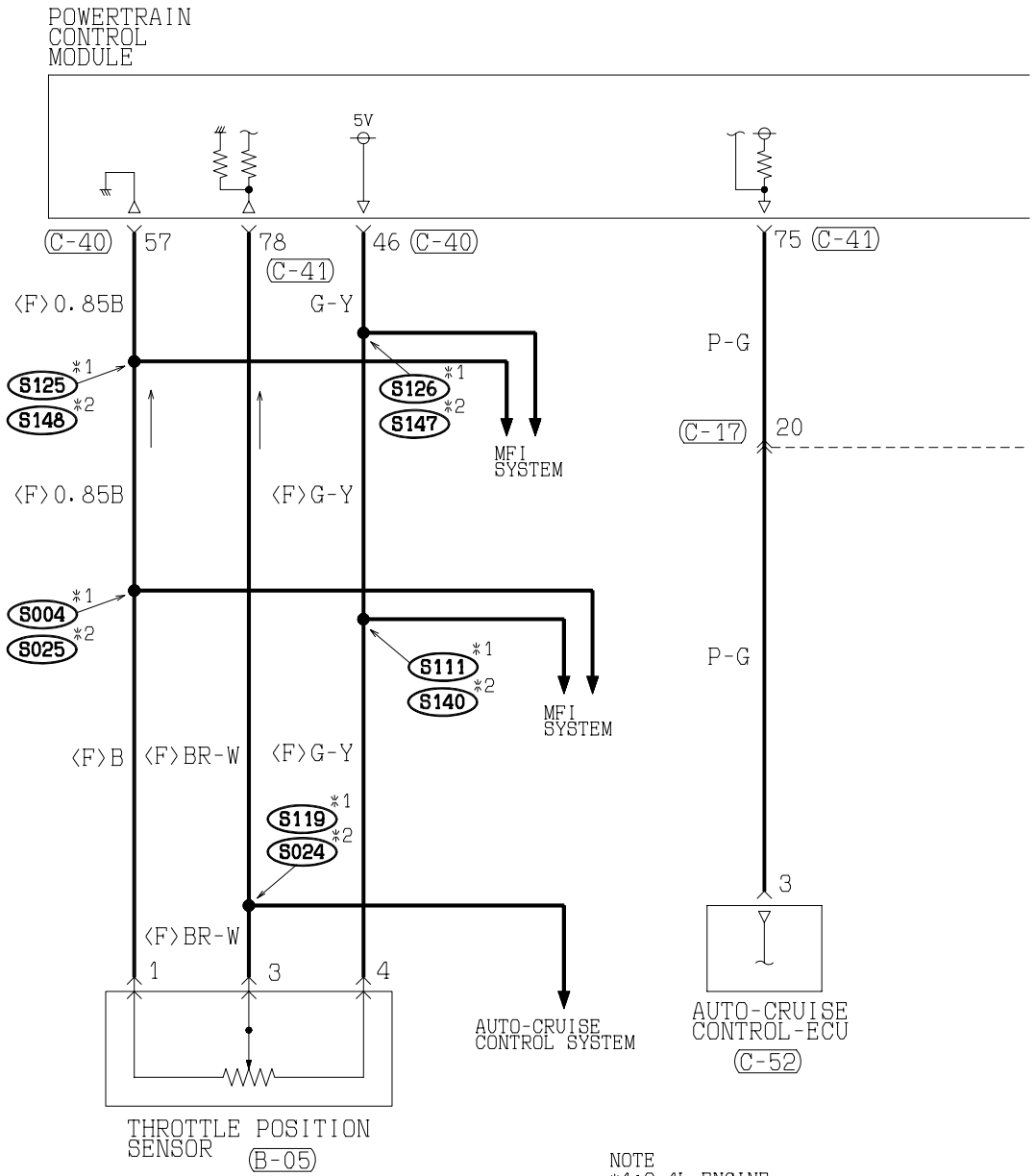

TSB Revision

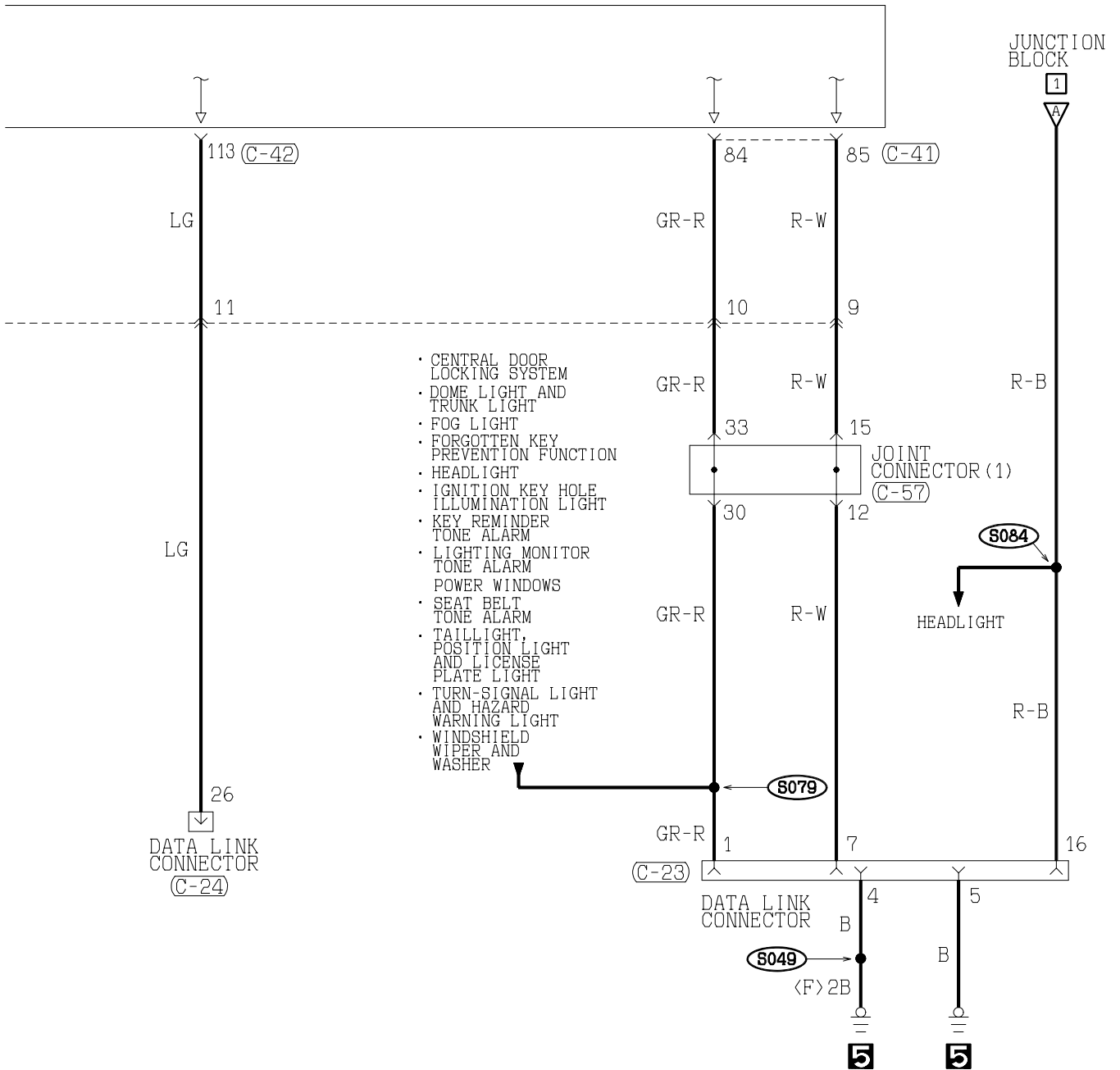

(C-41) (MU803782)

71	72	73	74		75	76	77				
78	79	80	81	82	83	84	85	86	87	88	89
90	91	92	93	94	95	96	97	98			

(C-42) (MU803783)

101	102		103	104		105	106	107				
108	109	110	111	112	113	114	115	116	117	118	119	120
121	122	123	124	125	126	127	128	129	130			

(C-52) (MU801584)

1	2	3	4	5	6	7	8
9	10	11	12	13	14	15	16

(C-57)

1	2	3	4	5	6	7	8	9	10	11
12	13	14	15	16	17	18	19	20	21	22
23	24	25	26	27	28	29	30	31	32	33

WIRE COLOR CODE
 B : BLACK BR : BROWN G : GREEN GR : GRAY L : BLUE LG : LIGHT GREEN O : ORANGE
 P : PINK R : RED SB : SKY BLUE V : VIOLET W : WHITE Y : YELLOW

H1507M02DB

TSB Revision

HEADLIGHT

1

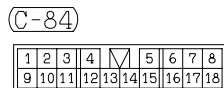
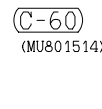
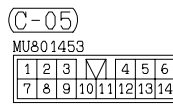
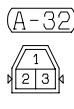
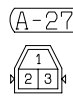
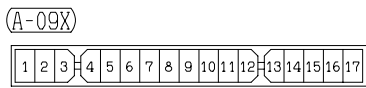
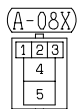
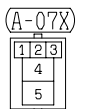
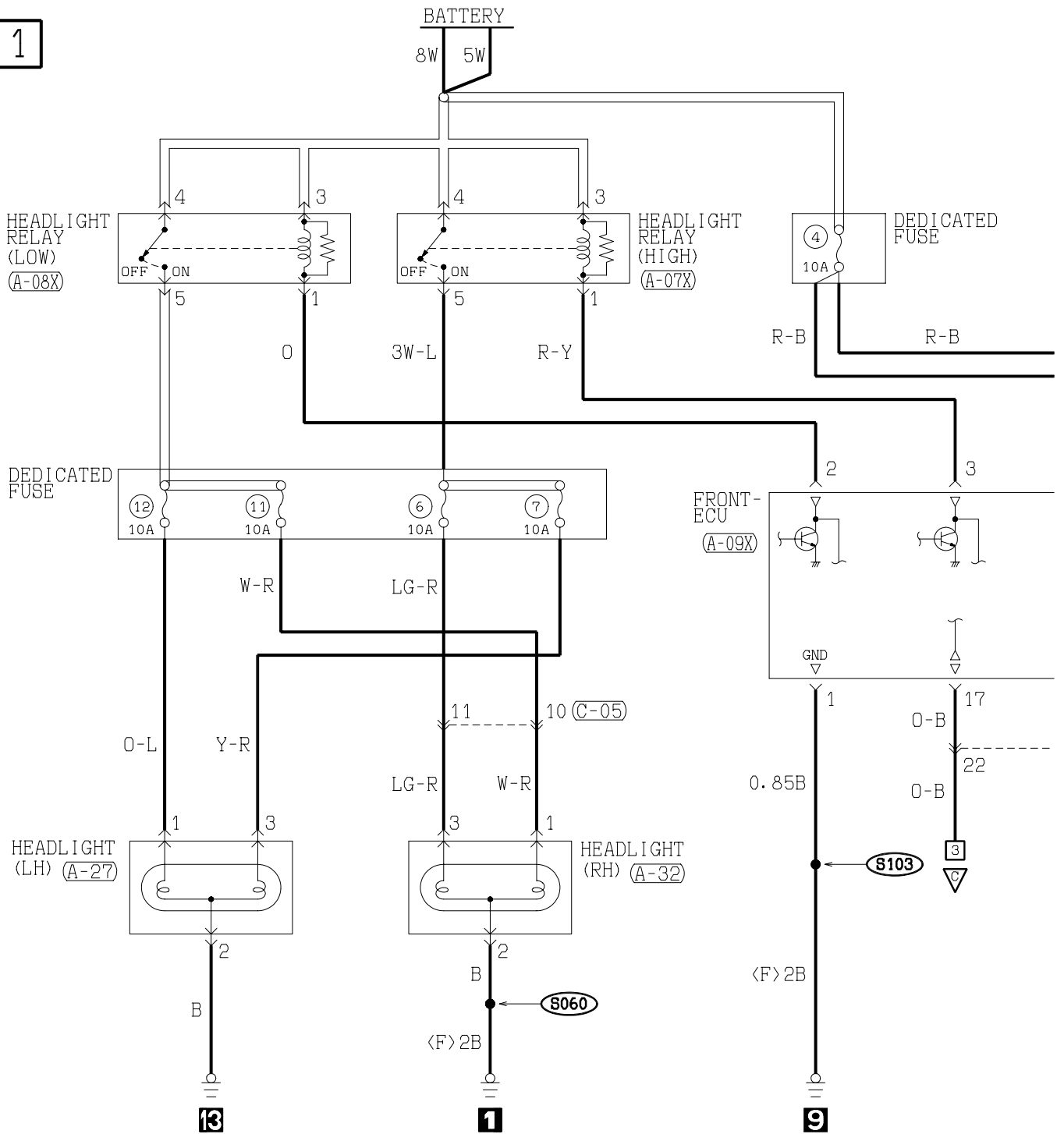

TSB Revision

2

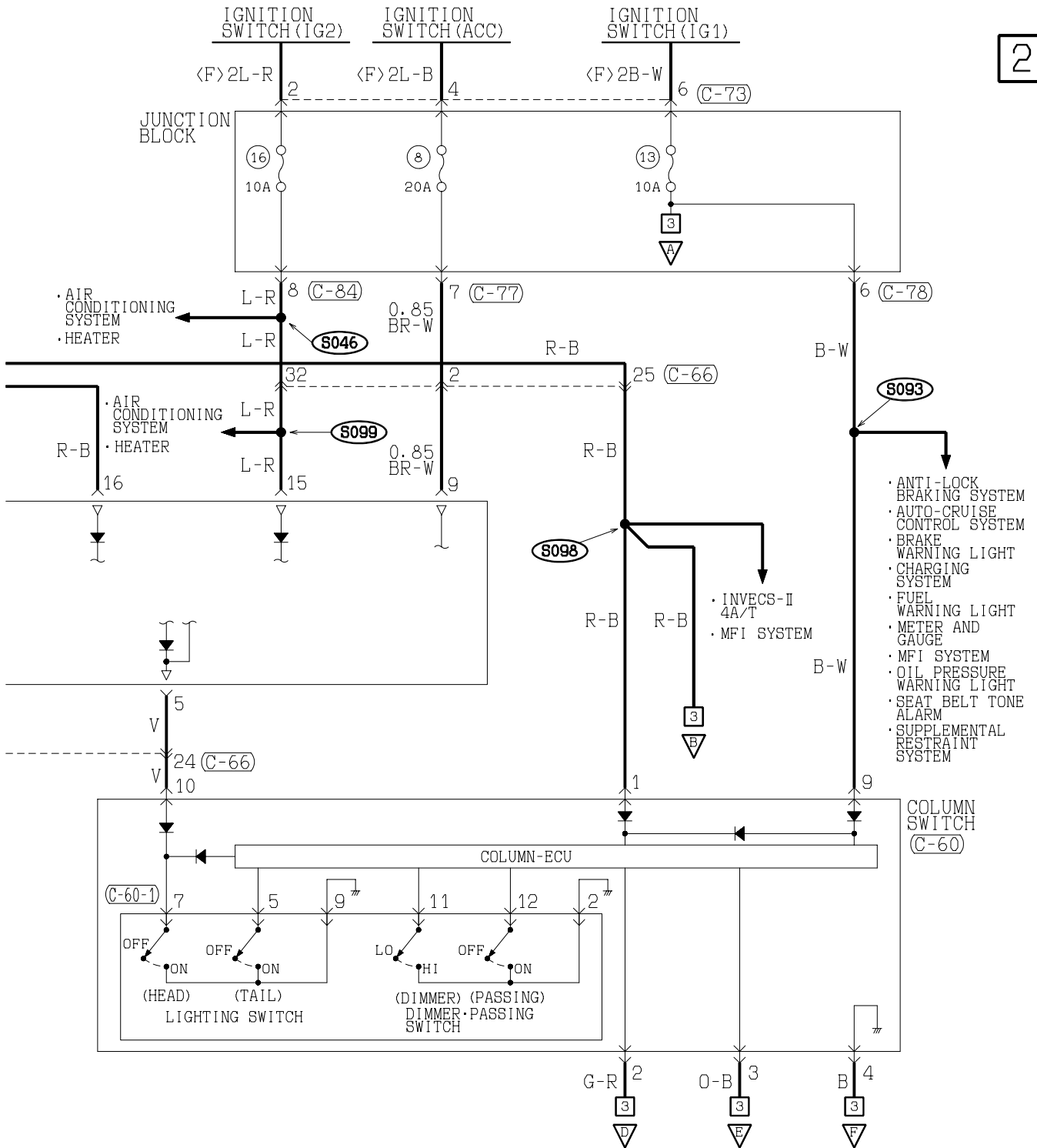

(C-60-1)

UPPER SIDE

1	2	3	4	5	6	7	8	9	10	11	12
---	---	---	---	---	---	---	---	---	----	----	----

(C-66)

1	2	3	4	5	6	7	8	9	10	11	12	13
14	15	16	17	18	19	20	21	22	23	24	25	38
26	27	28	29					30	31			
32	33	34	35			36	37					

(C-73)

MU801331

1	2
3	4
5	6

(C-77)

1	2	3	4	5	6	7	8	9	10
11	12	13	14	15	16	17	18	19	20
21	22								

WIRE COLOR CODE

- B : BLACK
- L : BLUE
- R : RED
- Y : YELLOW
- BR : BROWN
- LG : LIGHT GREEN
- SB : SKY BLUE
- G : GREEN
- O : ORANGE
- V : VIOLET
- GR : GRAY
- P : PINK
- W : WHITE

H1S08M04AB

TSB Revision

HEADLIGHT (CONTINUED)

3

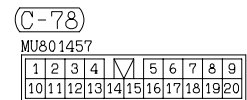
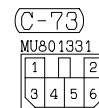
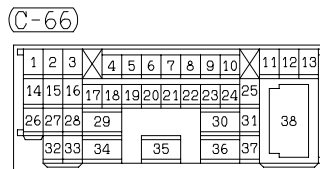
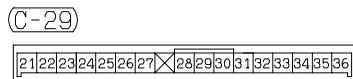
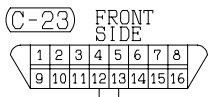
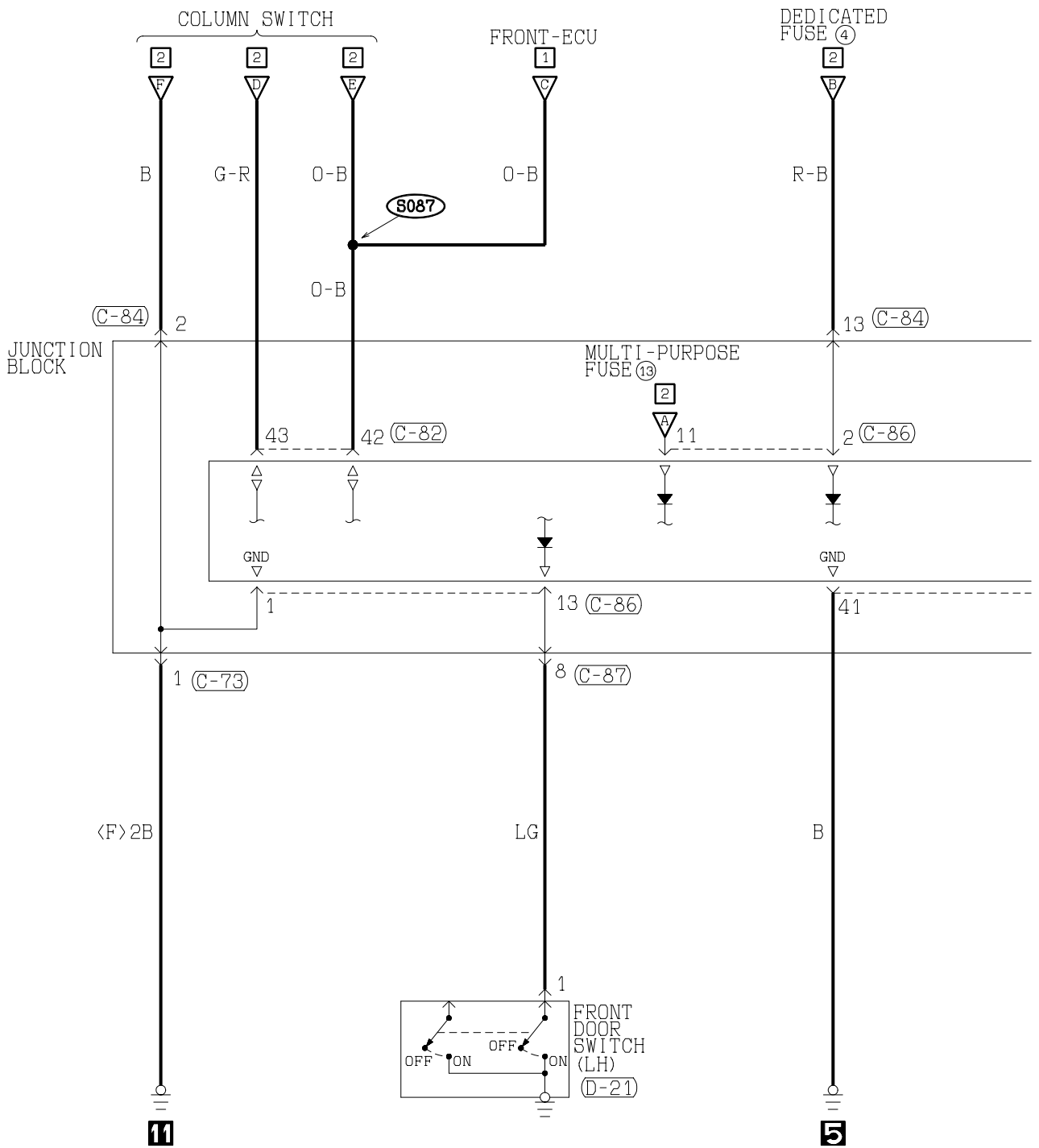

TSB Revision

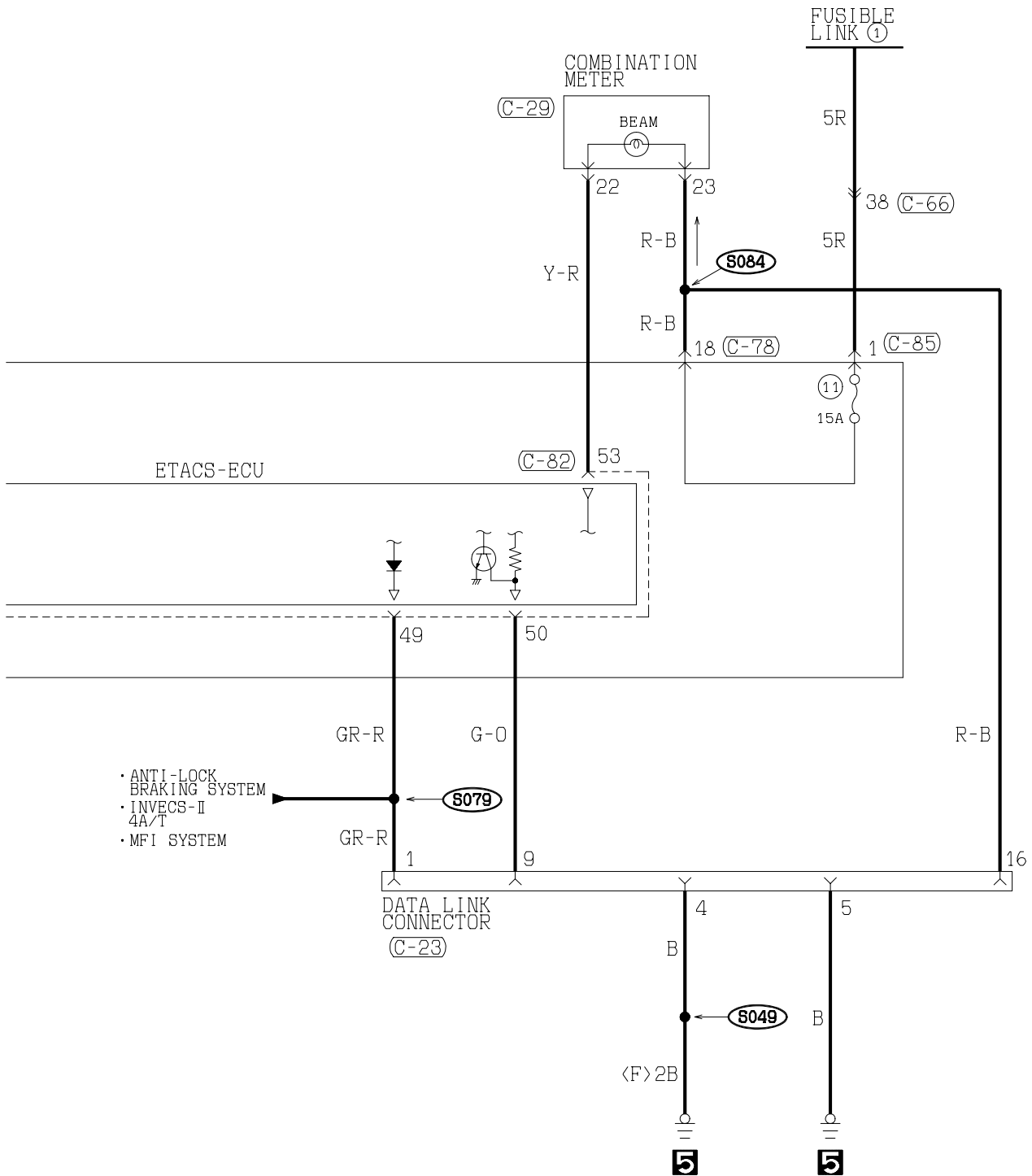

(C-82) (MU801584)



(C-84)

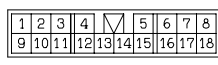

(C-85)



(C-86)

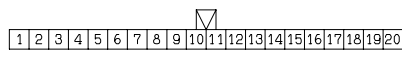

(C-87)

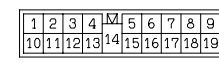

(D-21)



WIRE COLOR CODE

B : BLACK BR : BROWN G : GREEN GR : GRAY L : BLUE LG : LIGHT GREEN O : ORANGE
P : PINK R : RED SB : SKY BLUE V : VIOLET W : WHITE Y : YELLOW

H1508M04BB

TSB Revision

TAIL LIGHT, POSITION LIGHT AND LICENSE PLATE LIGHT

1

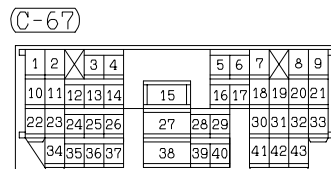
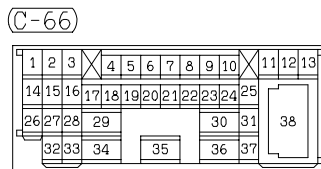
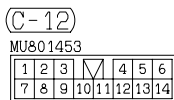
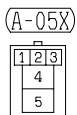
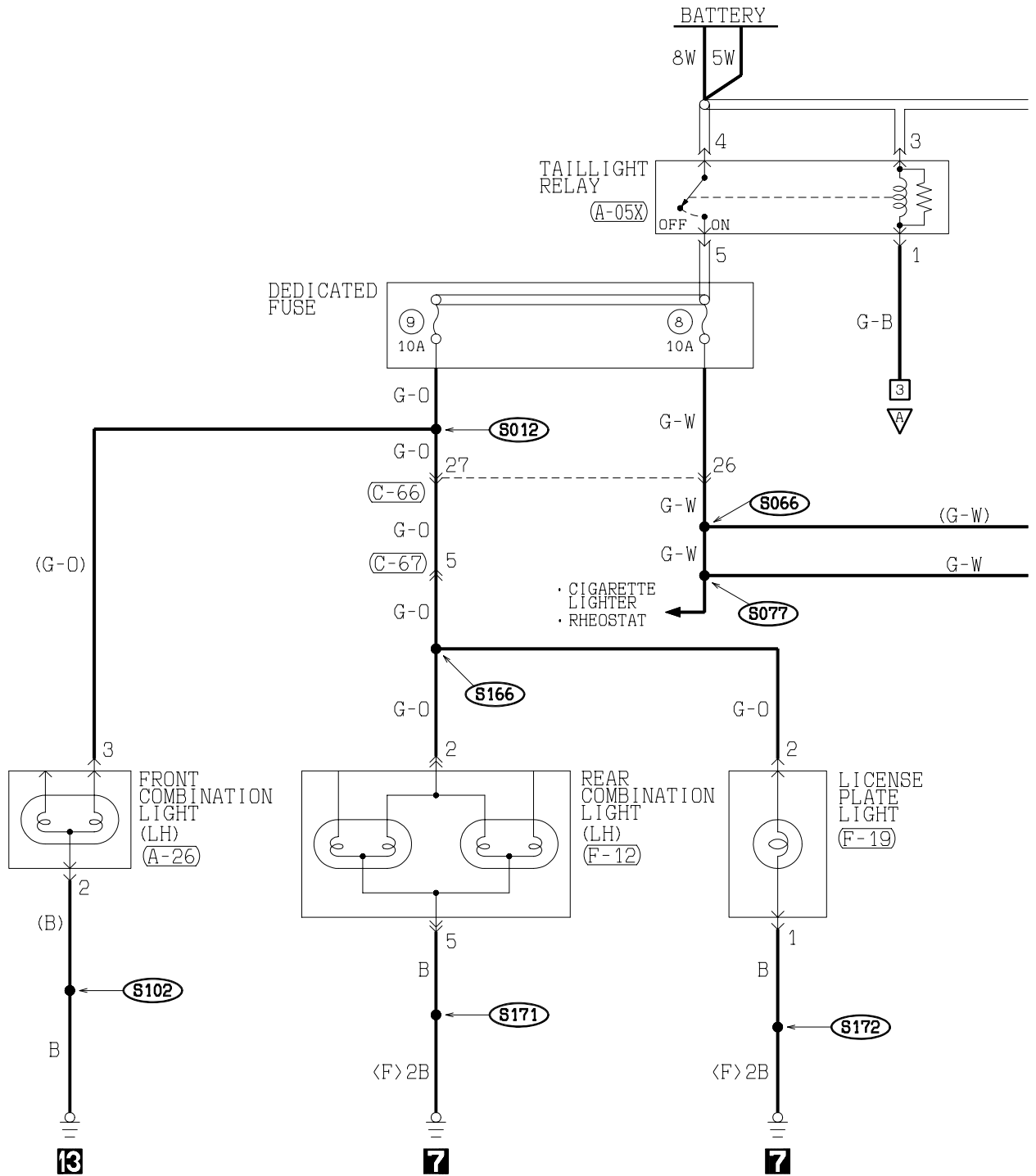

2

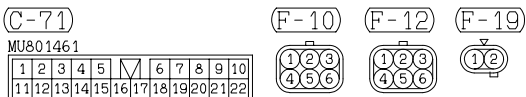
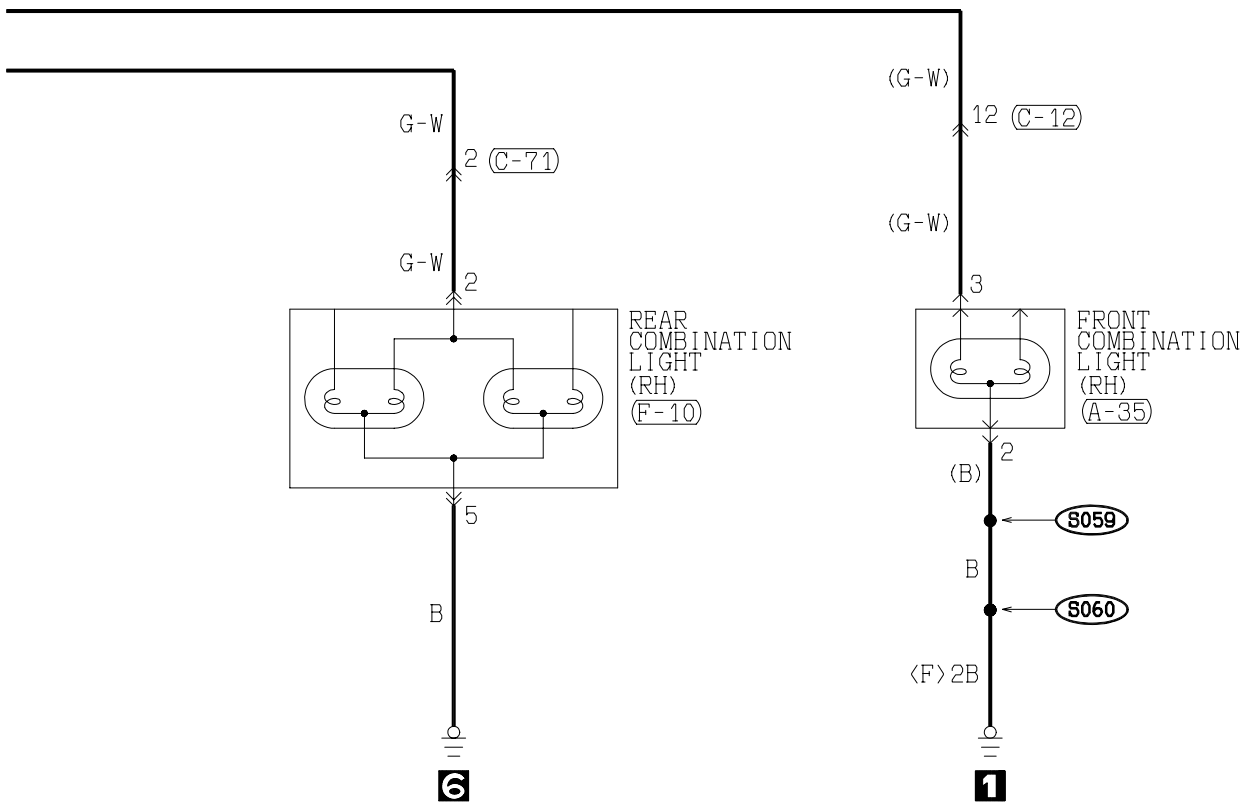
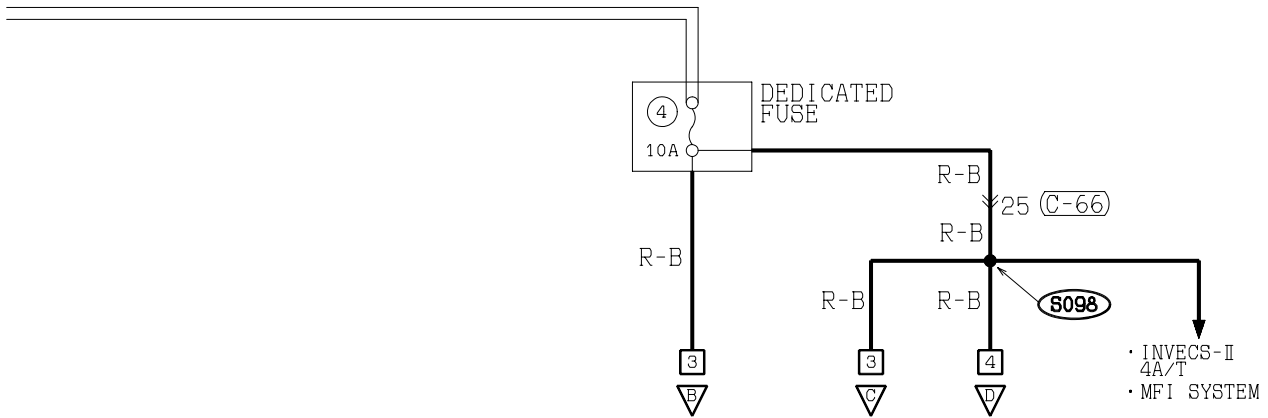

WIRE COLOR CODE
 B : BLACK BR : BROWN G : GREEN GR : GRAY L : BLUE LG : LIGHT GREEN O : ORANGE
 P : PINK R : RED SB : SKY BLUE V : VIOLET W : WHITE Y : YELLOW

H1S08M05AB

TSB Revision

TAILLIGHT, POSITION LIGHT AND LICENSE PLATE LIGHT (CONTINUED)

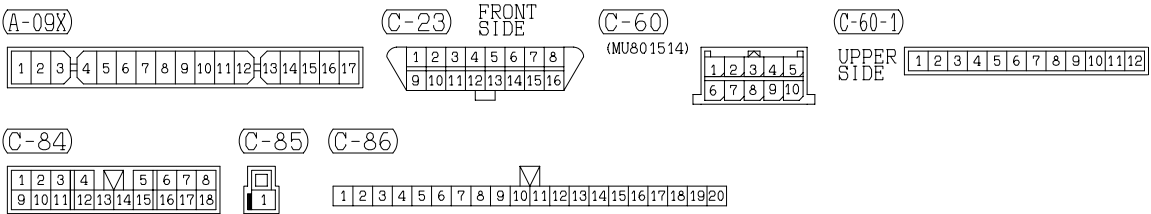
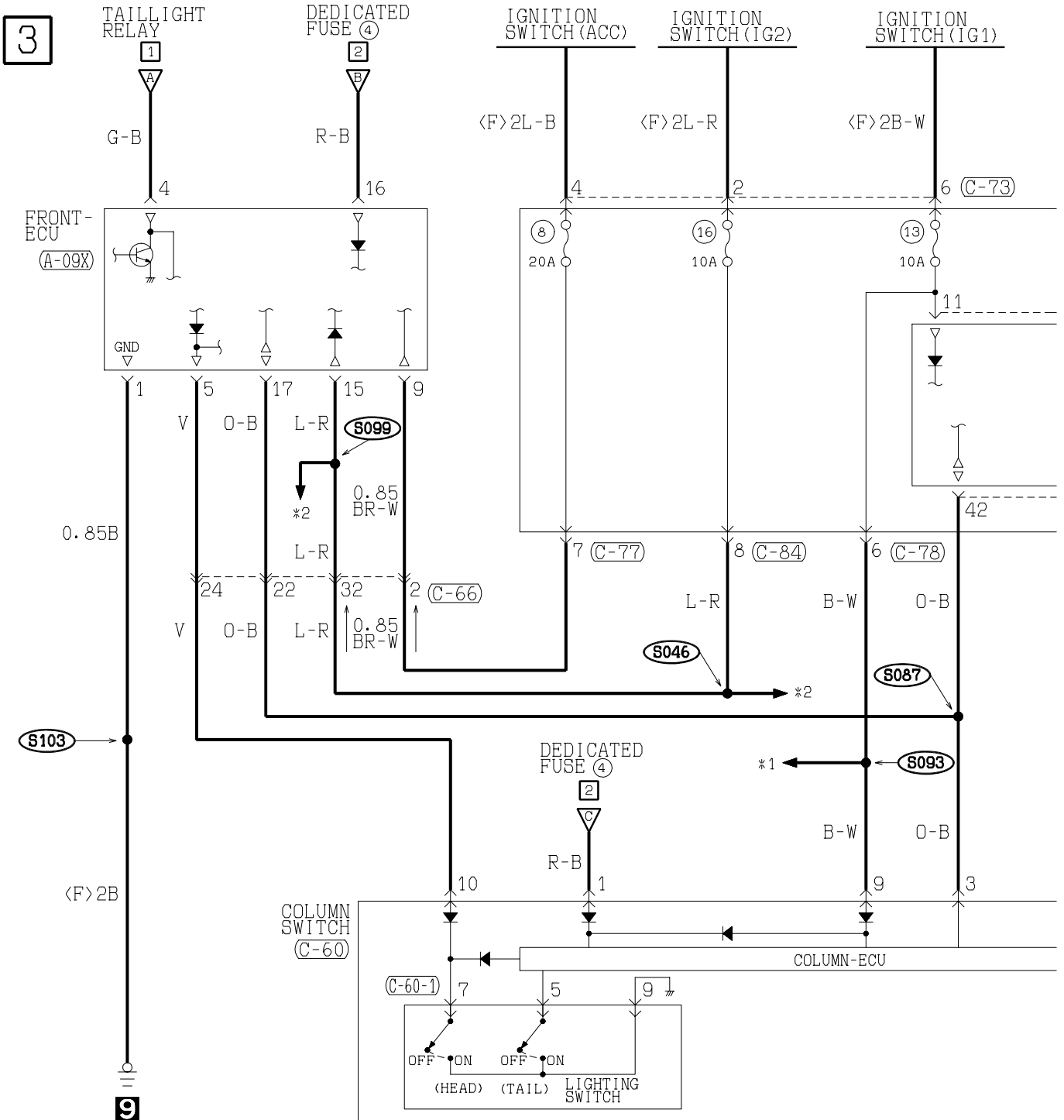

H1S08M05BA

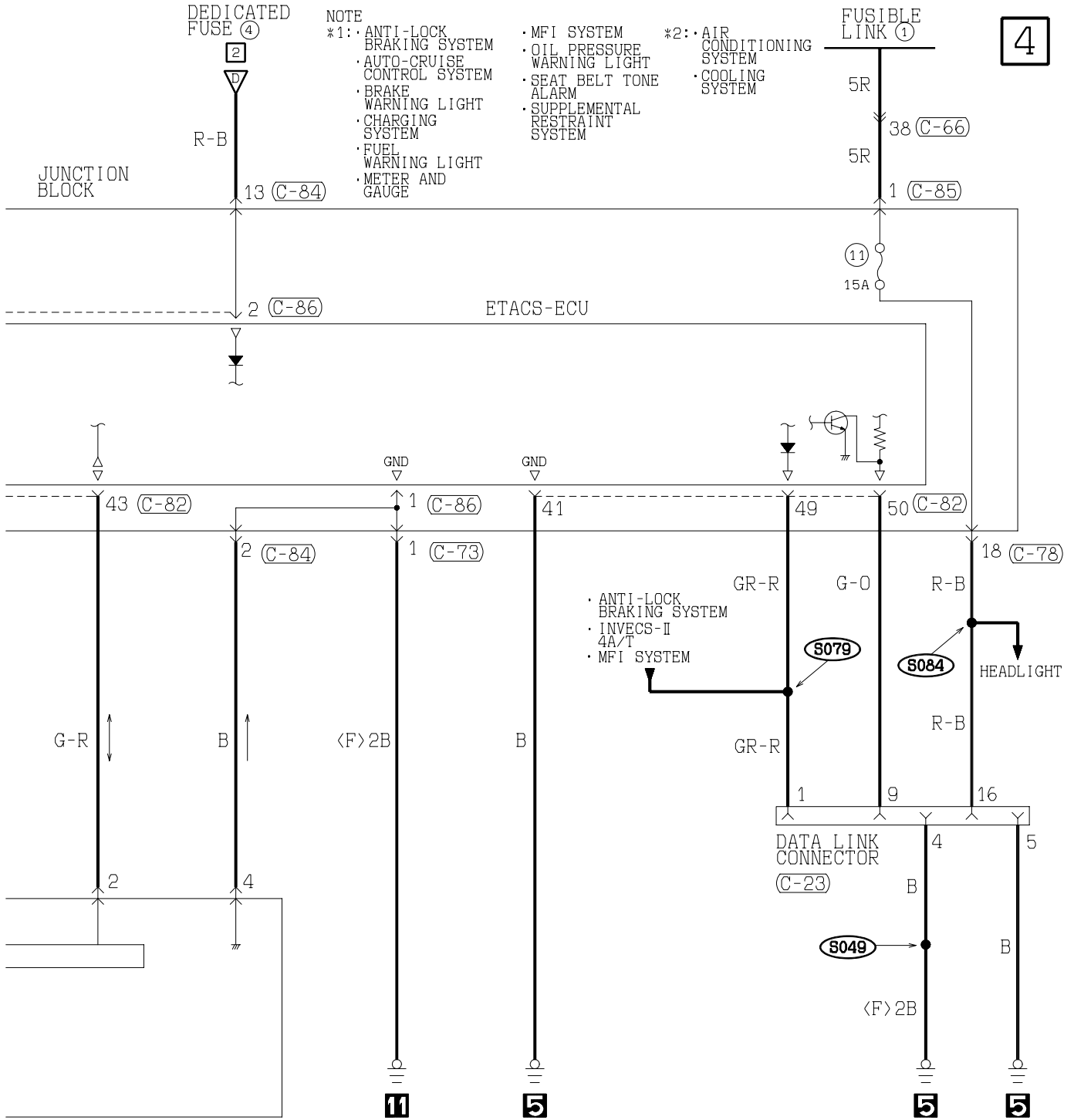

4

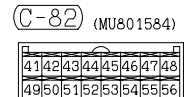
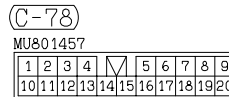
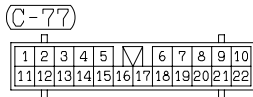
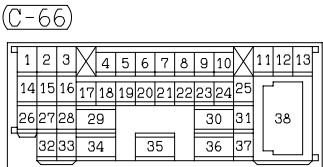

WIRE COLOR CODE
 B : BLACK LG : LIGHT GREEN G : GREEN L : BLUE
 BR : BROWN O : ORANGE GR : GRAY R : RED
 W : WHITE SB : SKY BLUE P : PINK Y : YELLOW
 V : VIOLET

H1S08M05BB

TSB Revision

FOG LIGHT

1

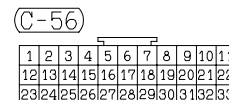
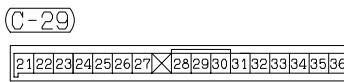
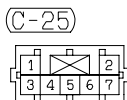
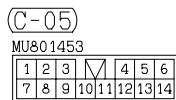
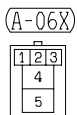
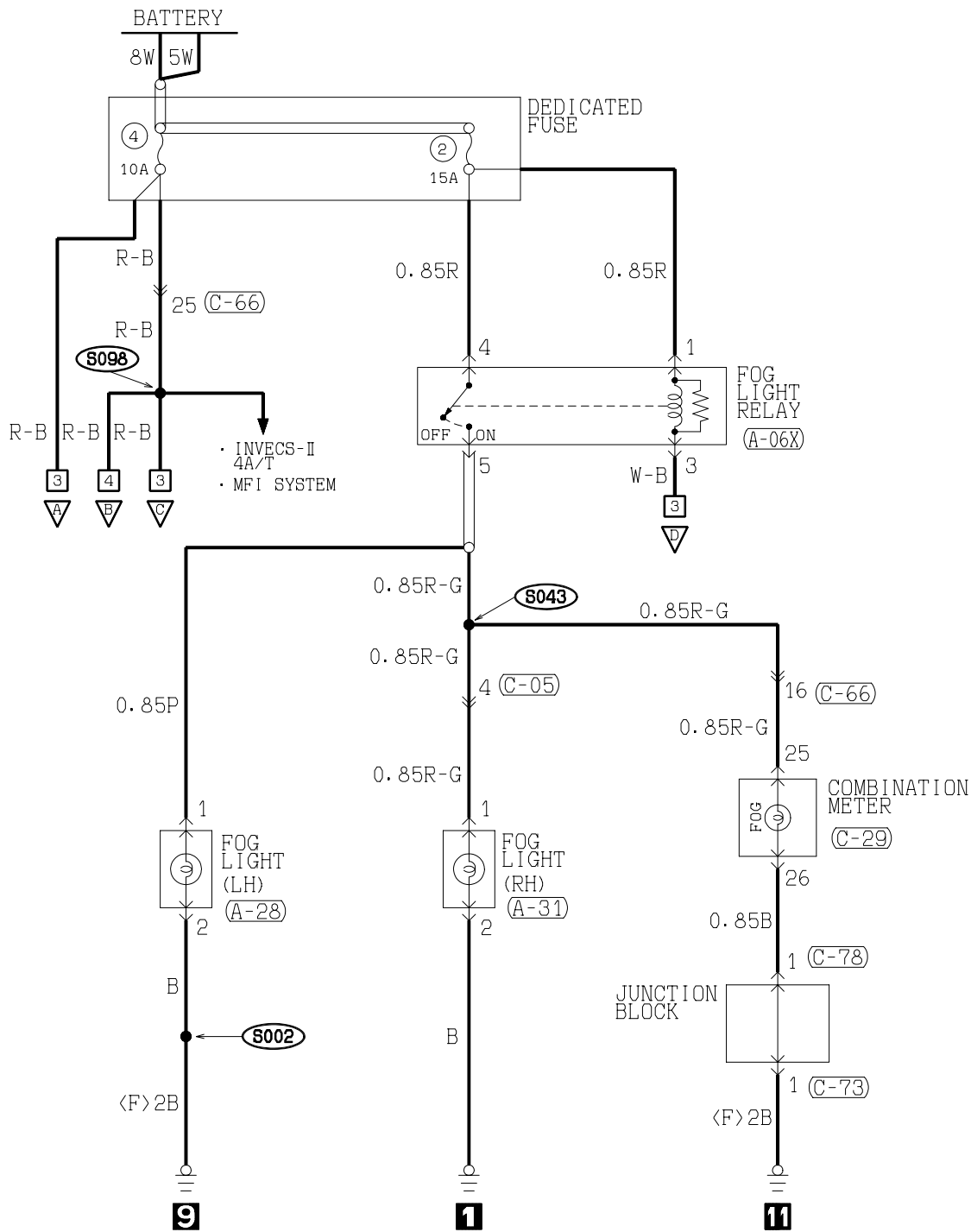

WIRE COLOR CODE
 B : BLACK BR : BROWN G : GREEN GR : GRAY L : BLUE LG : LIGHT GREEN O : ORANGE
 P : PINK R : RED SB : SKY BLUE V : VIOLET W : WHITE Y : YELLOW

TSB Revision

2

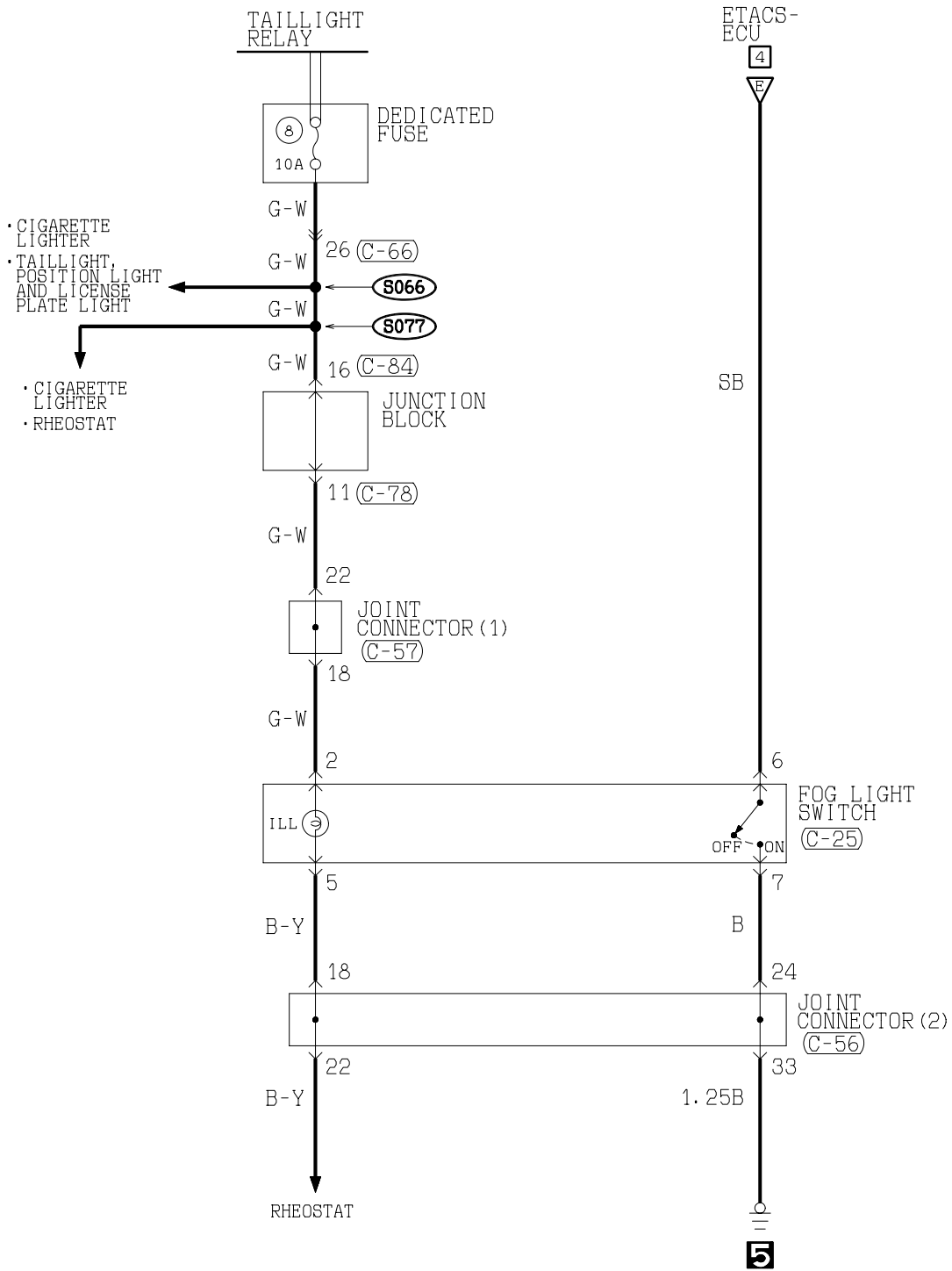

(C-57)

1	2	3	4	5	6	7	8	9	10	11
12	13	14	15	16	17	18	19	20	21	22
23	24	25	26	27	28	29	30	31	32	33

(C-66)

1	2	3	4	5	6	7	8	9	10	11	12	13
14	15	16	17	18	19	20	21	22	23	24	25	
26	27	28	29			30	31			38		
32	33	34		35		36	37					

(C-73)

MU801331

1		2
3	4	5
	6	

(C-78)

MU801457

1	2	3	4	5	6	7	8	9
10	11	12	13	14	15	16	17	18
19	20							

(C-84)

1	2	3	4	5	6	7	8
9	10	11	12	13	14	15	16
17	18						

TSB Revision

FOG LIGHT (CONTINUED)

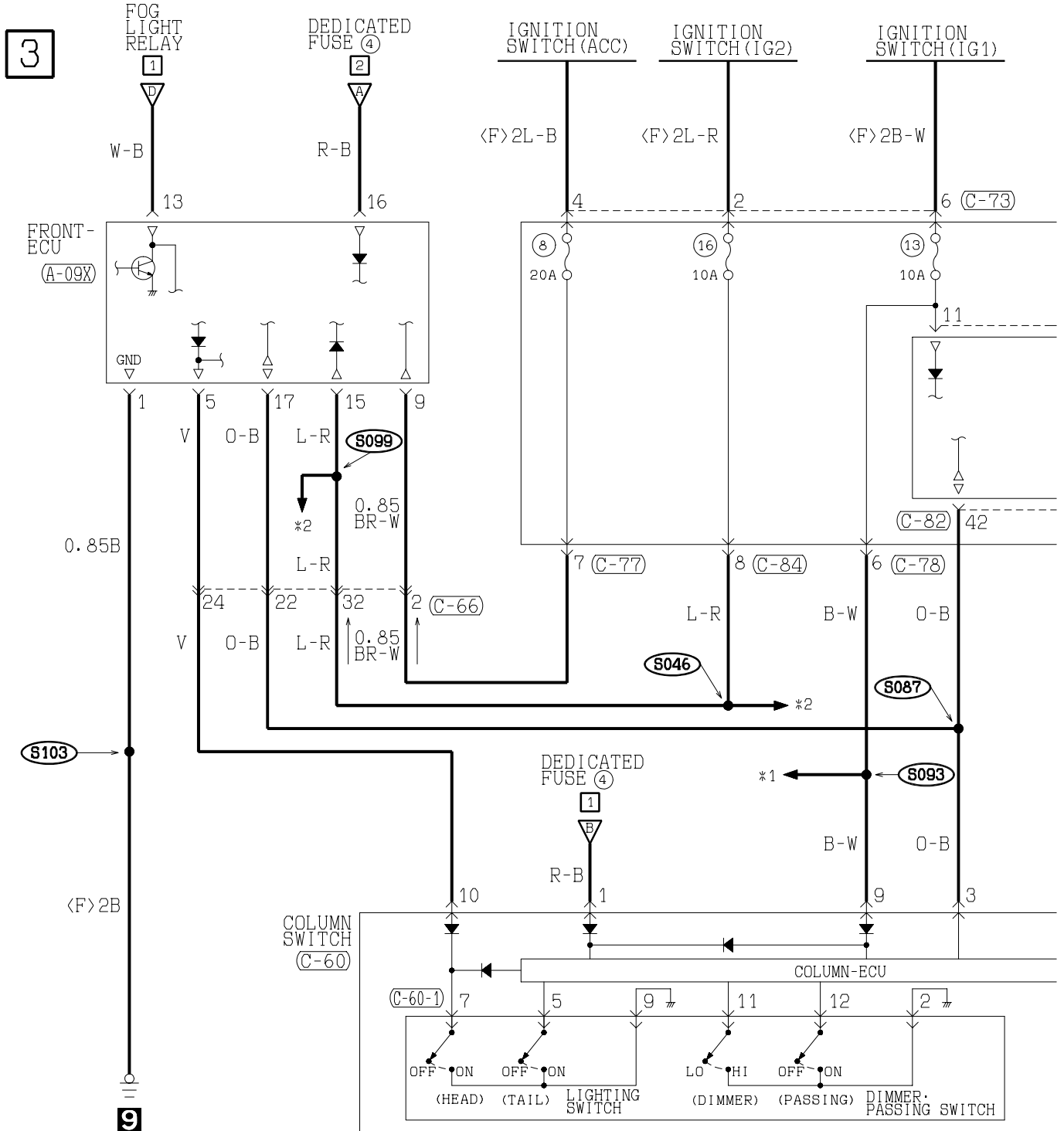

(A-09X)

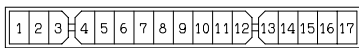

(C-23) FRONT SIDE

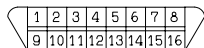

(C-60)

(MU801514)

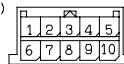

(C-60-1)

UPPER SIDE

1	2	3	4	5	6	7	8	9	10	11	12
---	---	---	---	---	---	---	---	---	----	----	----

(C-84)

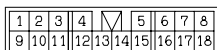

(C-85)



(C-86)

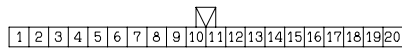

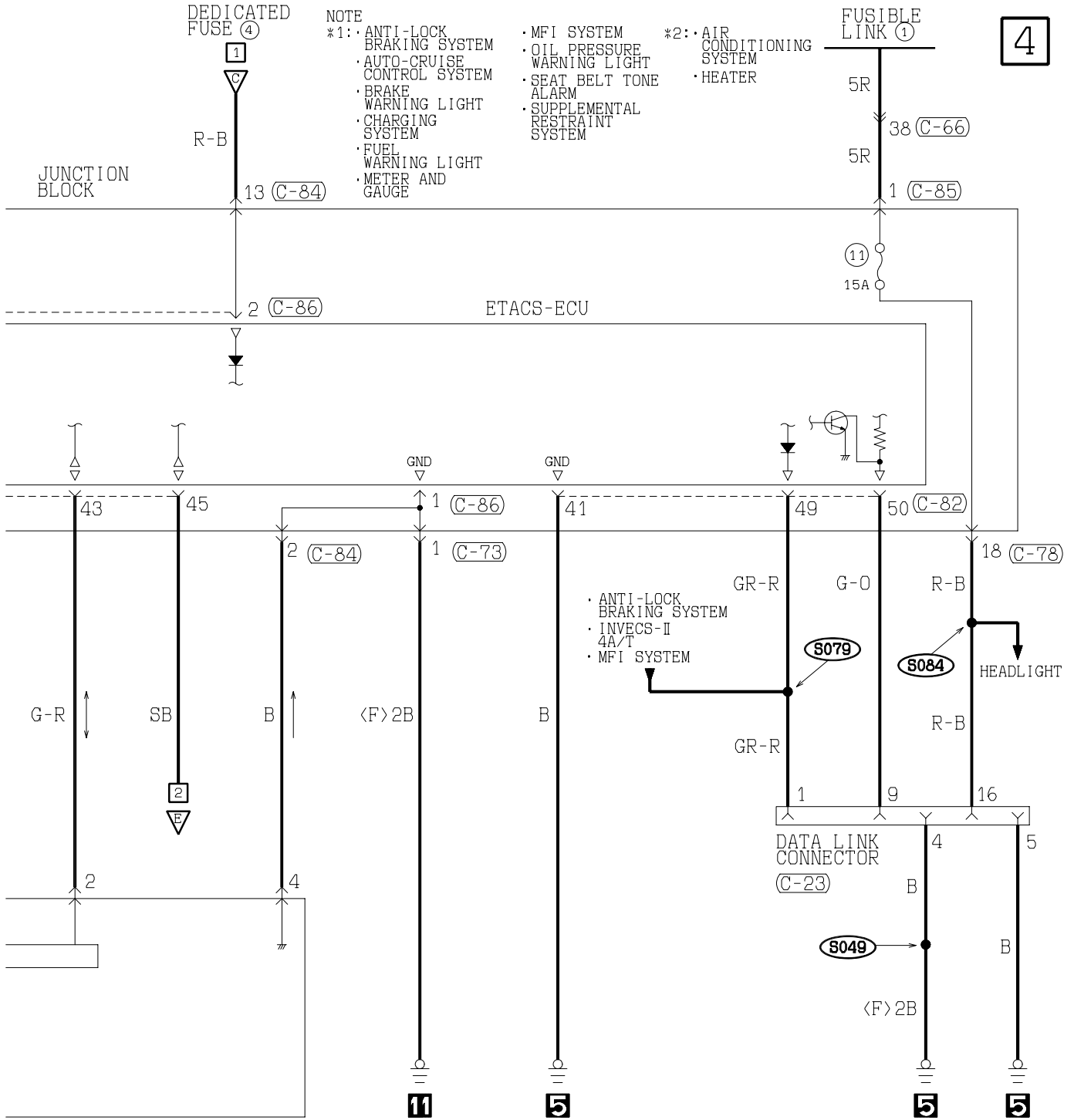

- NOTE
- *1:
 - ANTI-LOCK BRAKING SYSTEM
 - AUTO-CRUISE CONTROL SYSTEM
 - BRAKE WARNING LIGHT
 - CHARGING SYSTEM
 - FUEL WARNING LIGHT
 - METER AND GAUGE
 - *2:
 - MFI SYSTEM
 - OIL PRESSURE WARNING LIGHT
 - SEAT BELT TONE ALARM
 - SUPPLEMENTAL RESTRAINT SYSTEM
 - AIR CONDITIONING SYSTEM
 - HEATER

4

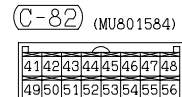
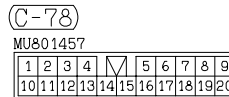
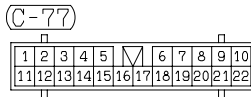
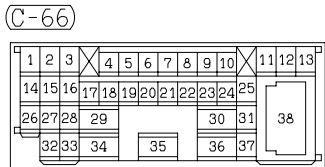

WIRE COLOR CODE

B : BLACK	LG : LIGHT GREEN	G : GREEN	L : BLUE
BR : BROWN	O : ORANGE	GR : GRAY	R : RED
W : WHITE	SB : SKY BLUE	P : PINK	Y : YELLOW
V : VIOLET			

H1508M06BB

TSB Revision

DOME LIGHT AND TRUNK LIGHT

1

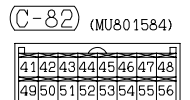
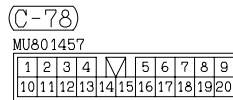
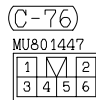
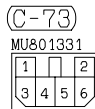
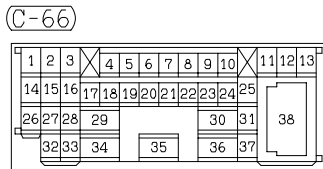
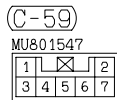
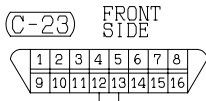
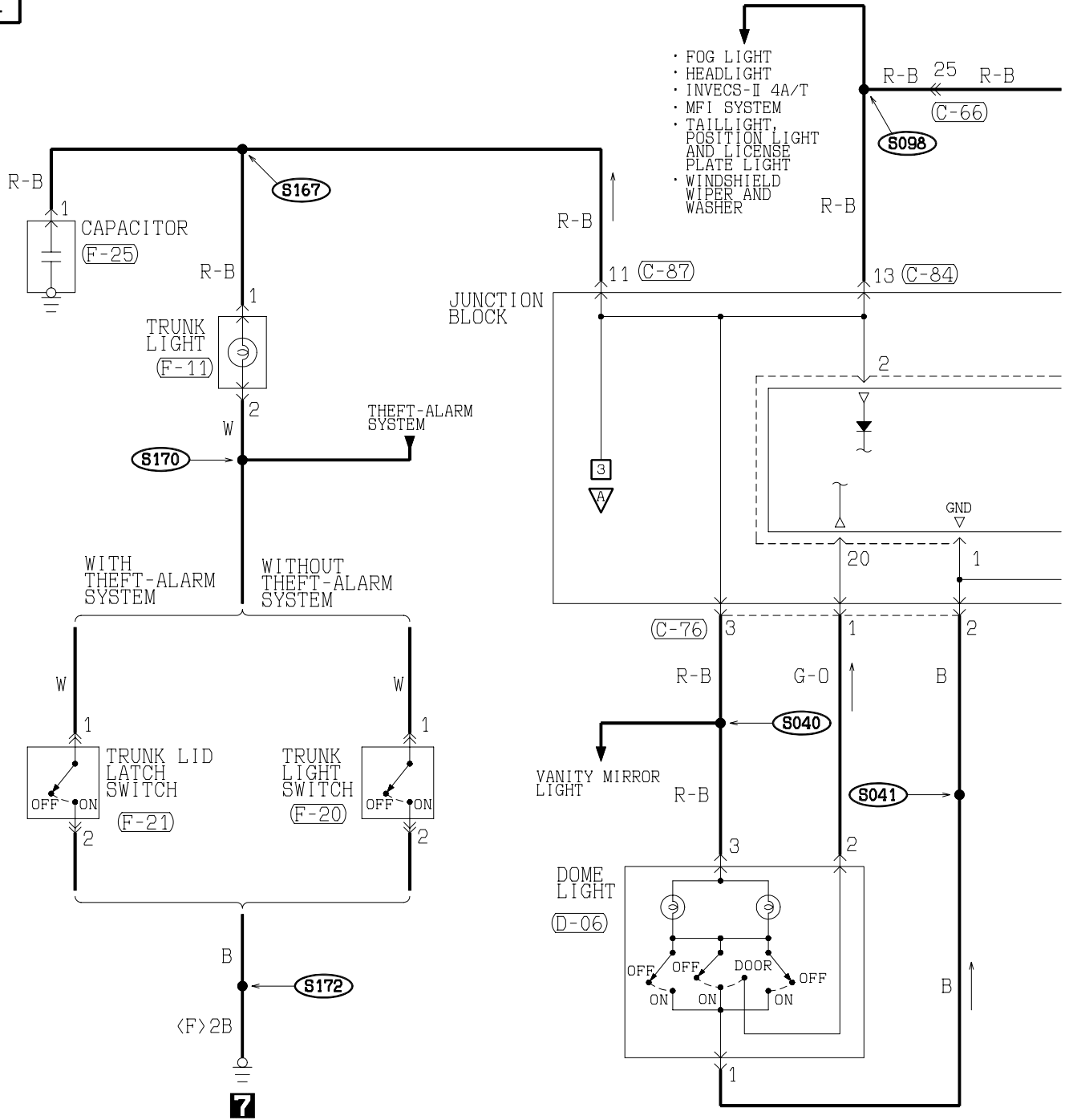

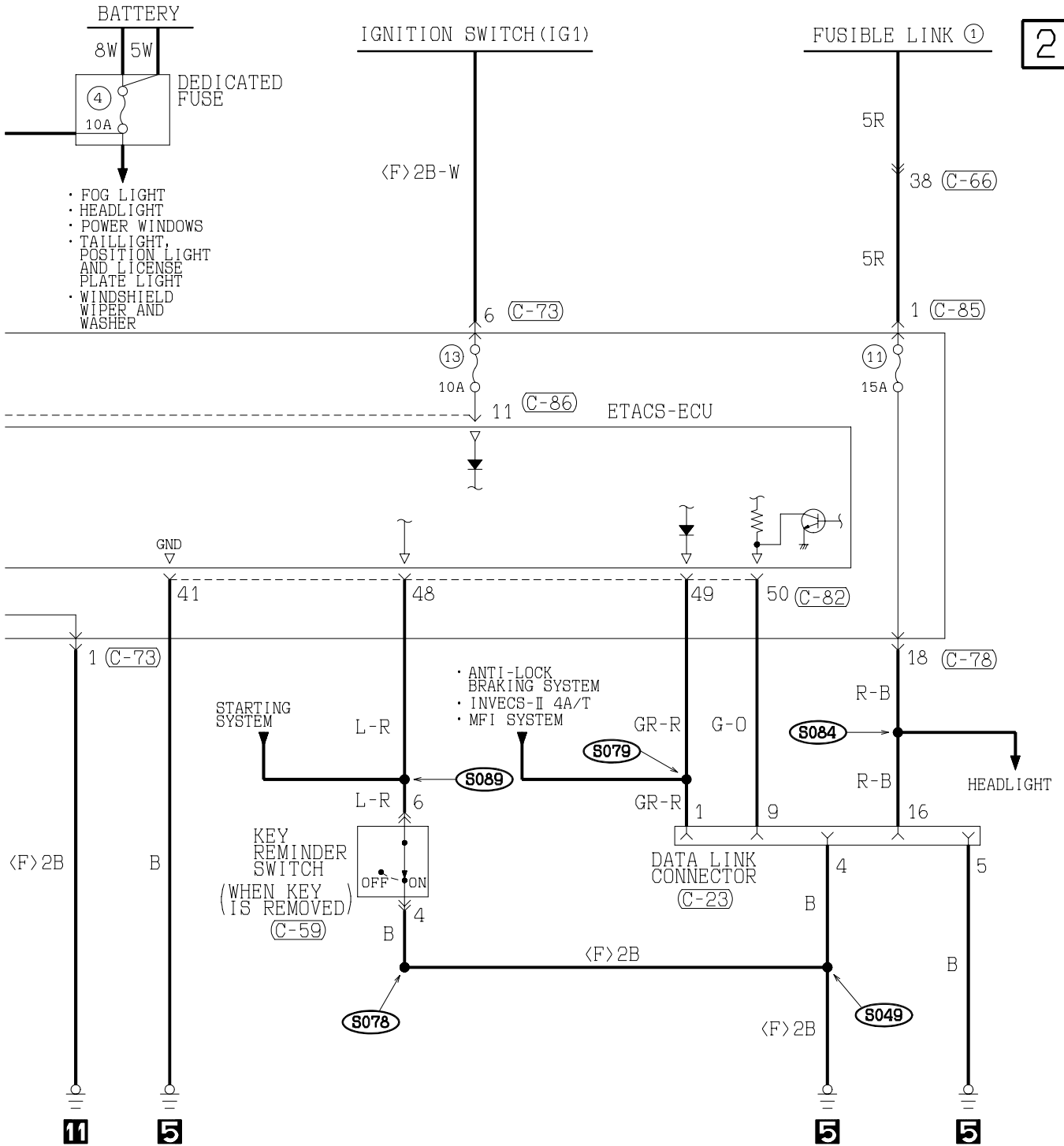

2

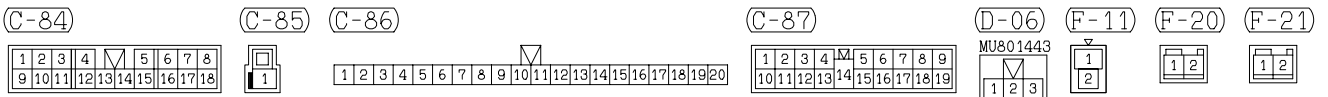

Wire color code
 B:Black LG:Light green G:Green L:Blue W:White Y:Yellow SB:Sky blue
 BR:Brown O:Orange GR:Gray R:Red P:Pink V:Violet

TSB Revision

DOME LIGHT AND TRUNK LIGHT

3

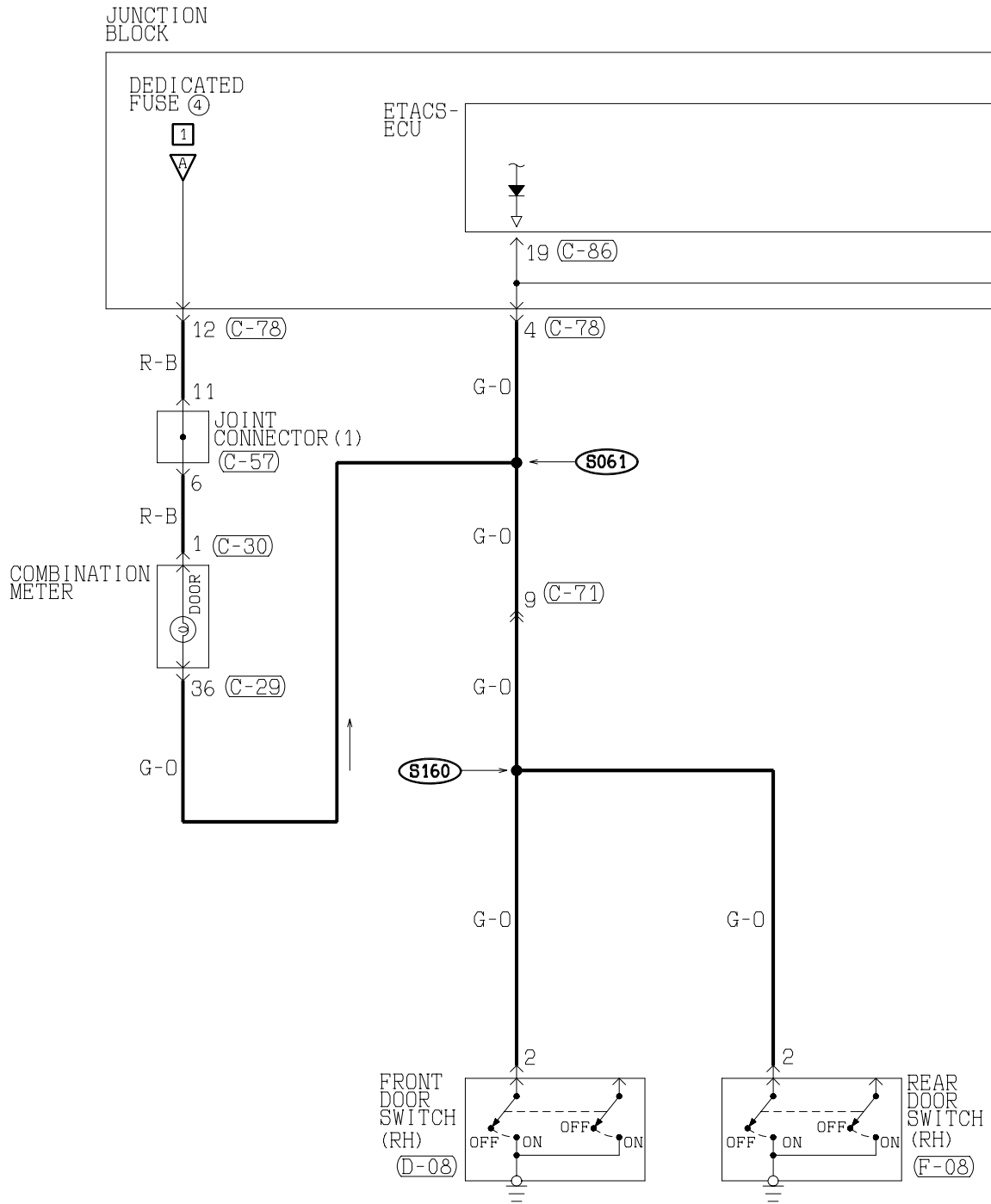

(C-29)

2	1	2	2	2	3	2	4	2	5	2	6	2	7	X	2	8	2	9	3	0	3	1	3	2	3	3	3	4	3	5	3	6
---	---	---	---	---	---	---	---	---	---	---	---	---	---	---	---	---	---	---	---	---	---	---	---	---	---	---	---	---	---	---	---	---

(C-30)

1	2	3	4	5	6	7	8	9	X	10	11	12	13	14	15	16
---	---	---	---	---	---	---	---	---	---	----	----	----	----	----	----	----

(C-57)

1	2	3	4	5	6	7	8	9	10	11
12	13	14	15	16	17	18	19	20	21	22
23	24	25	26	27	28	29	30	31	32	33

(C-68)

1	2	3	4	5	X	6	7	8	9		
10	11	12	13	14	15	16	17	18	19	20	21
22	23	24	25	26	27	28	29	30	31	32	

(C-87)

1	2	3	4	M	5	6	7	8	9
10	11	12	13	14	15	16	17	18	19

(D-08)

1	2	3
---	---	---

(D-21)

1	2	3
---	---	---

(E-15)

1	2	3
---	---	---

MU802341



(F-08)

1	2	3
---	---	---

(F-14)

1	2	3
---	---	---

TSB Revision

4

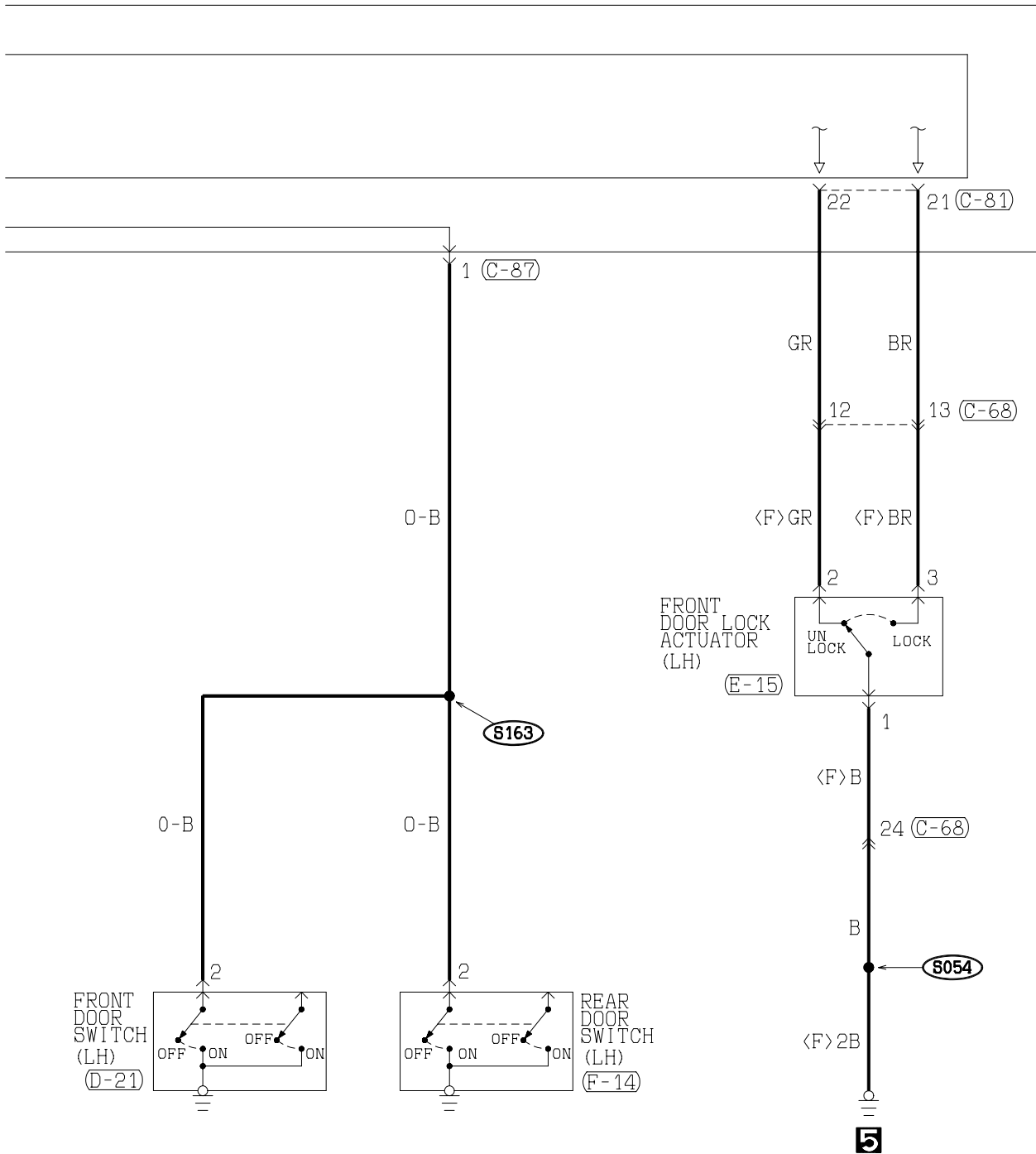

(C-71)
MU801461

1	2	3	4	5	6	7	8	9	10
11	12	13	14	15	16	17	18	19	20

(C-78)
MU801457

1	2	3	4	5	6	7	8	9
10	11	12	13	14	15	16	17	18

(C-81) (MU801585)

21	22	23	24	25	26	27	28	29	30
31	32	33	34	35	36	37	38	39	40

(C-86)

1	2	3	4	5	6	7	8	9	10	11	12	13	14	15	16	17	18	19	20
---	---	---	---	---	---	---	---	---	----	----	----	----	----	----	----	----	----	----	----

WIRE COLOR CODE

B : BLACK BR : BROWN G : GREEN GR : GRAY L : BLUE LG : LIGHT GREEN O : ORANGE
P : PINK R : RED SB : SKY BLUE V : VIOLET W : WHITE Y : YELLOW

H1508M07BB

TSB Revision

IGNITION KEY HOLE ILLUMINATION LIGHT

1

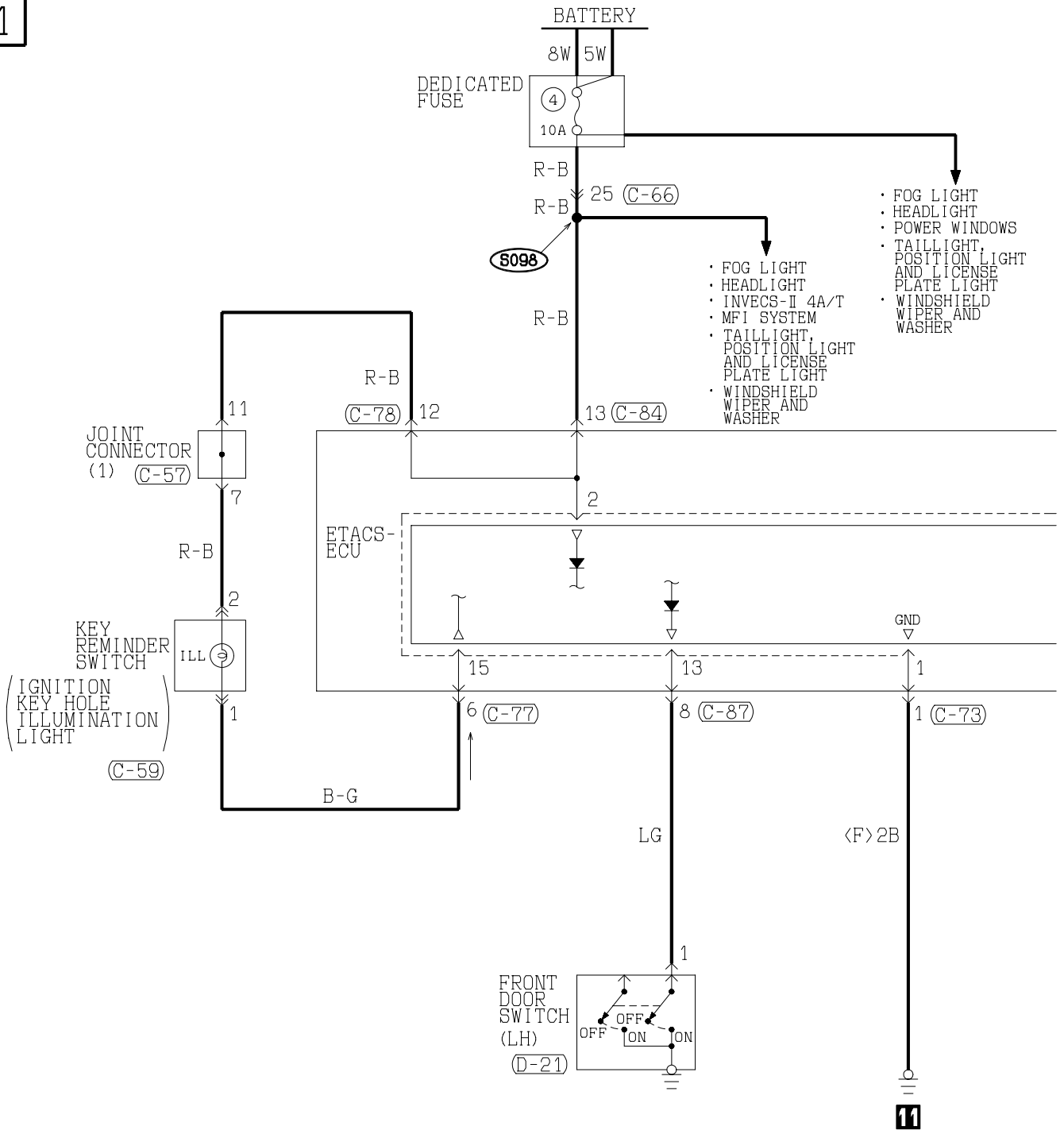

11

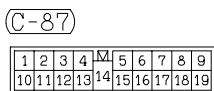
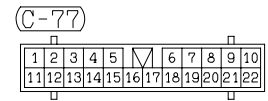
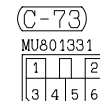
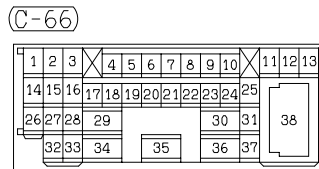
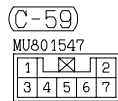
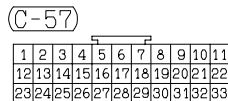
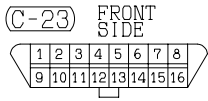

TSB Revision

2

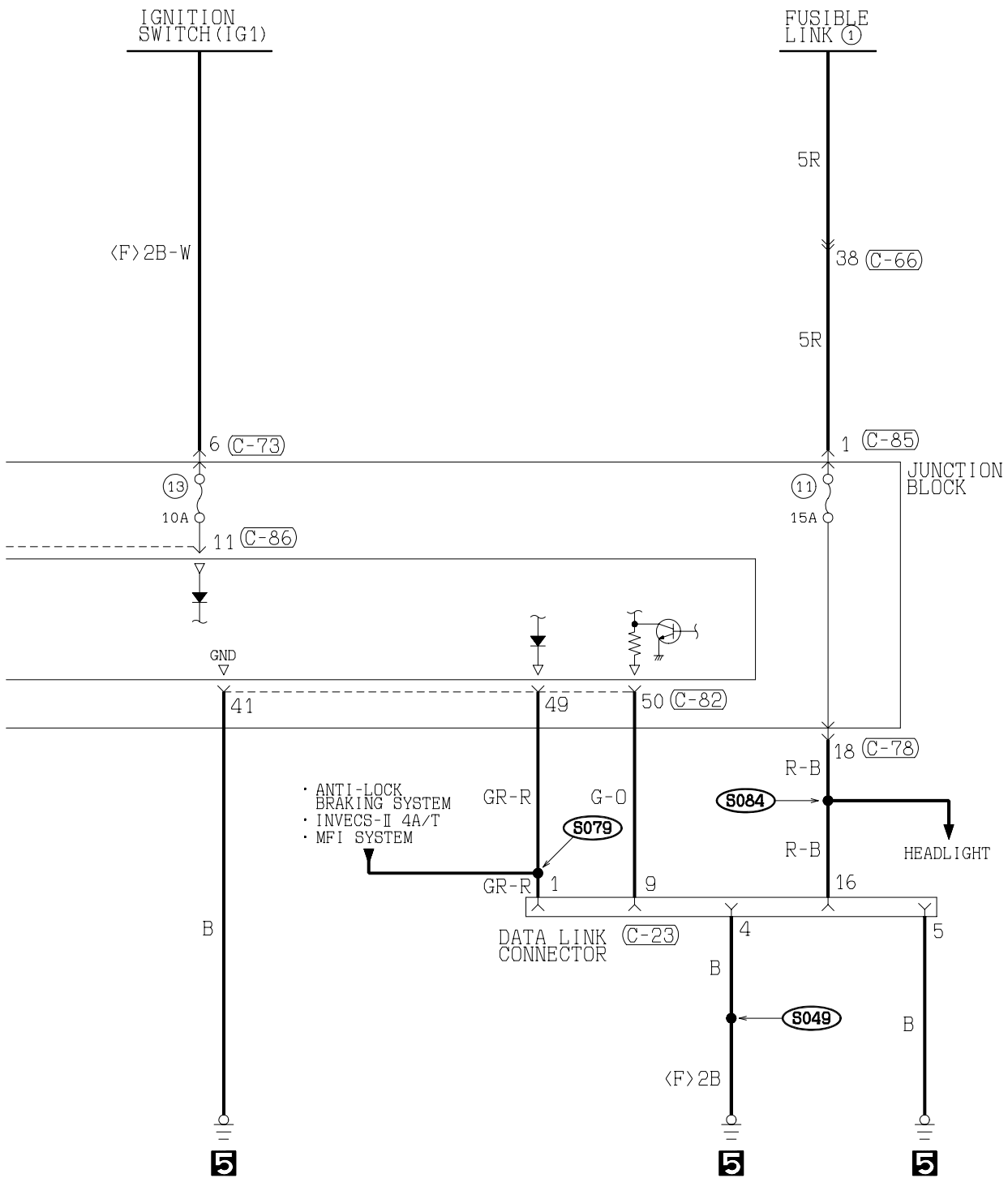

(C-78)

1	2	3	4	5	6	7	8	9		
10	11	12	13	14	15	16	17	18	19	20

(C-82) (MU801584)

41	42	43	44	45	46	47	48
49	50	51	52	53	54	55	56

(C-84)

1	2	3	4	5	6	7	8		
9	10	11	12	13	14	15	16	17	18

(C-85)

1

(C-86)

1	2	3	4	5	6	7	8	9	10	11	12	13	14	15	16	17	18	19	20
---	---	---	---	---	---	---	---	---	----	----	----	----	----	----	----	----	----	----	----

WIRE COLOR CODE

B : BLACK BR : BROWN
 P : PINK R : RED

G : GREEN SB : SKY BLUE

GR : GRAY V : VIOLET

L : BLUE W : WHITE

LG : LIGHT GREEN Y : YELLOW

O : ORANGE

TSB Revision

VANITY MIRROR LIGHT

1

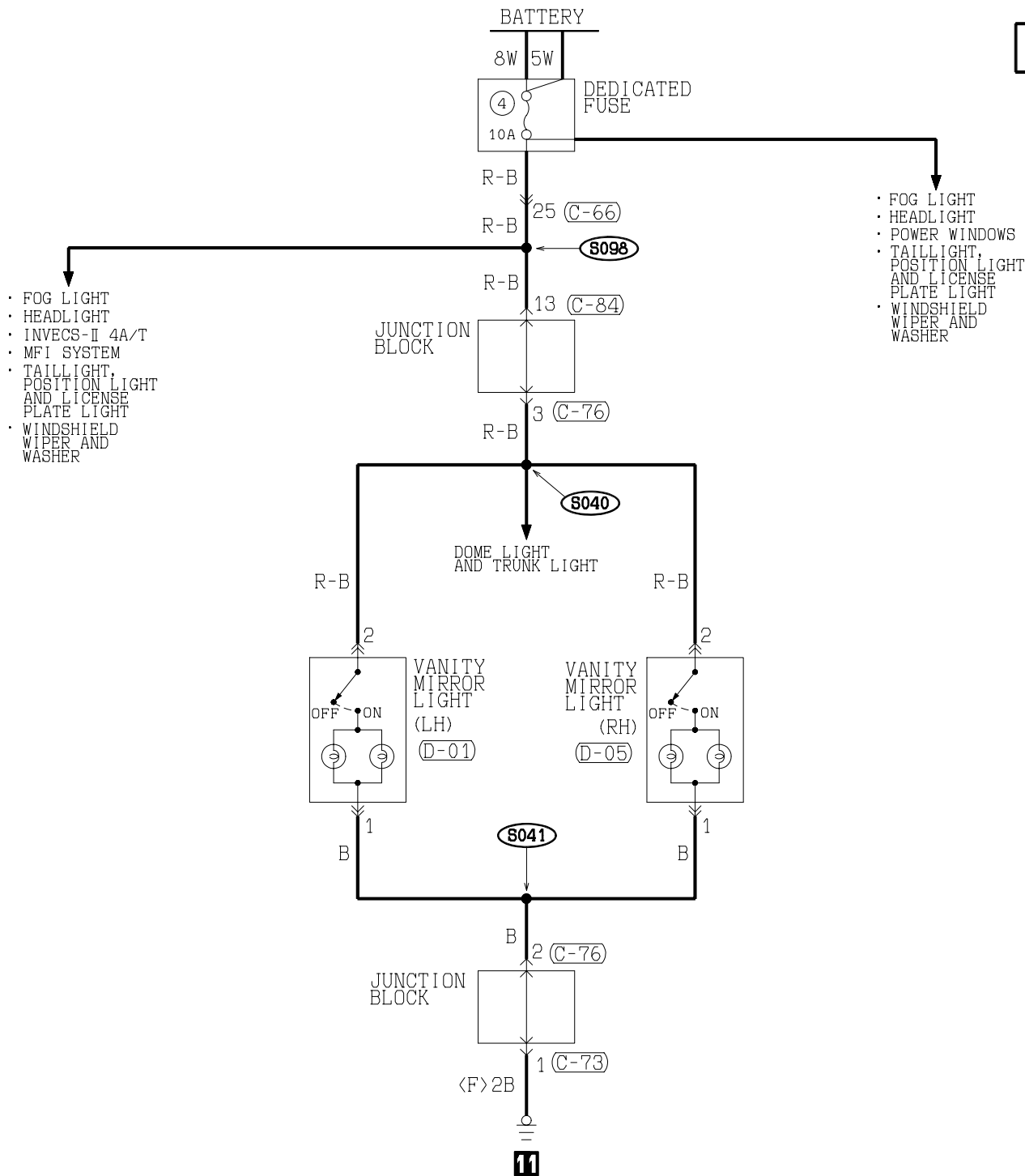

- FOG LIGHT
- HEADLIGHT
- INVECS-II 4A/T
- MFI SYSTEM
- TAILLIGHT, POSITION LIGHT AND LICENSE PLATE LIGHT
- WINDSHIELD WIPER AND WASHER

- FOG LIGHT
- HEADLIGHT
- POWER WINDOWS
- TAILLIGHT, POSITION LIGHT AND LICENSE PLATE LIGHT
- WINDSHIELD WIPER AND WASHER

(C-66)

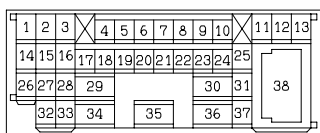

(C-73)

MU801331



(C-76)

MU801447



(C-84)

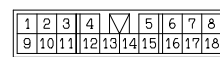

(D-01)



(D-05)



WIRE COLOR CODE
 B : BLACK BR : BROWN G : GREEN GR : GRAY
 L : BLUE LG : LIGHT GREEN O : ORANGE P : PINK
 R : RED SB : SKY BLUE V : VIOLET W : WHITE
 Y : YELLOW

TSB Revision

NOTES

TSB Revision

TURN-SIGNAL LIGHT AND HAZARD WARNING LIGHT

M19101002900063

1

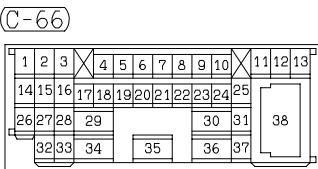
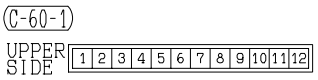
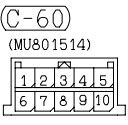
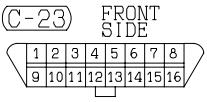
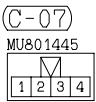
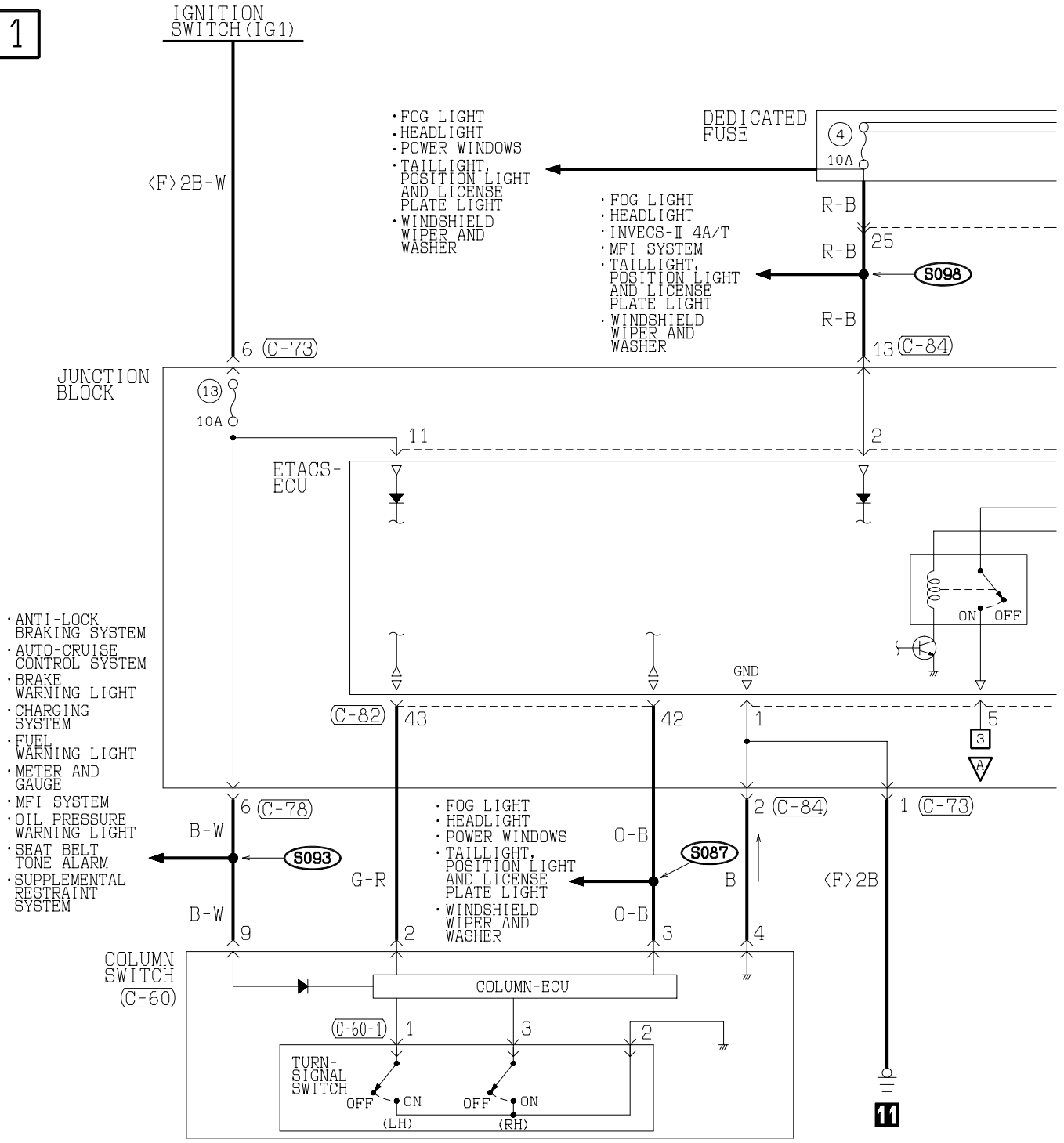

H1S09M05AA

TSB Revision

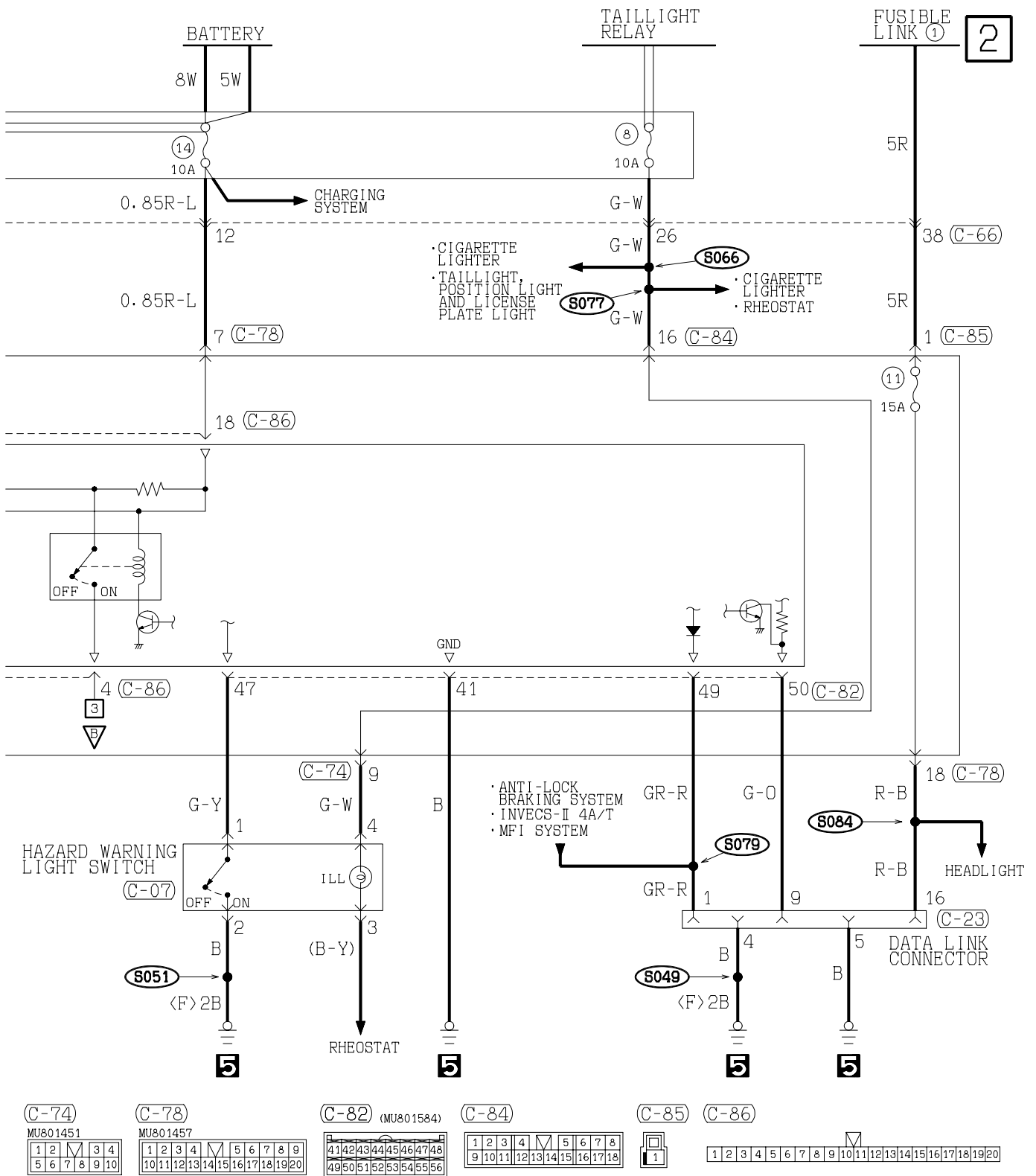

H1S09M05AB

TSB Revision

TURN-SIGNAL LIGHT AND HAZARD WARNING LIGHT (CONTINUED)

3

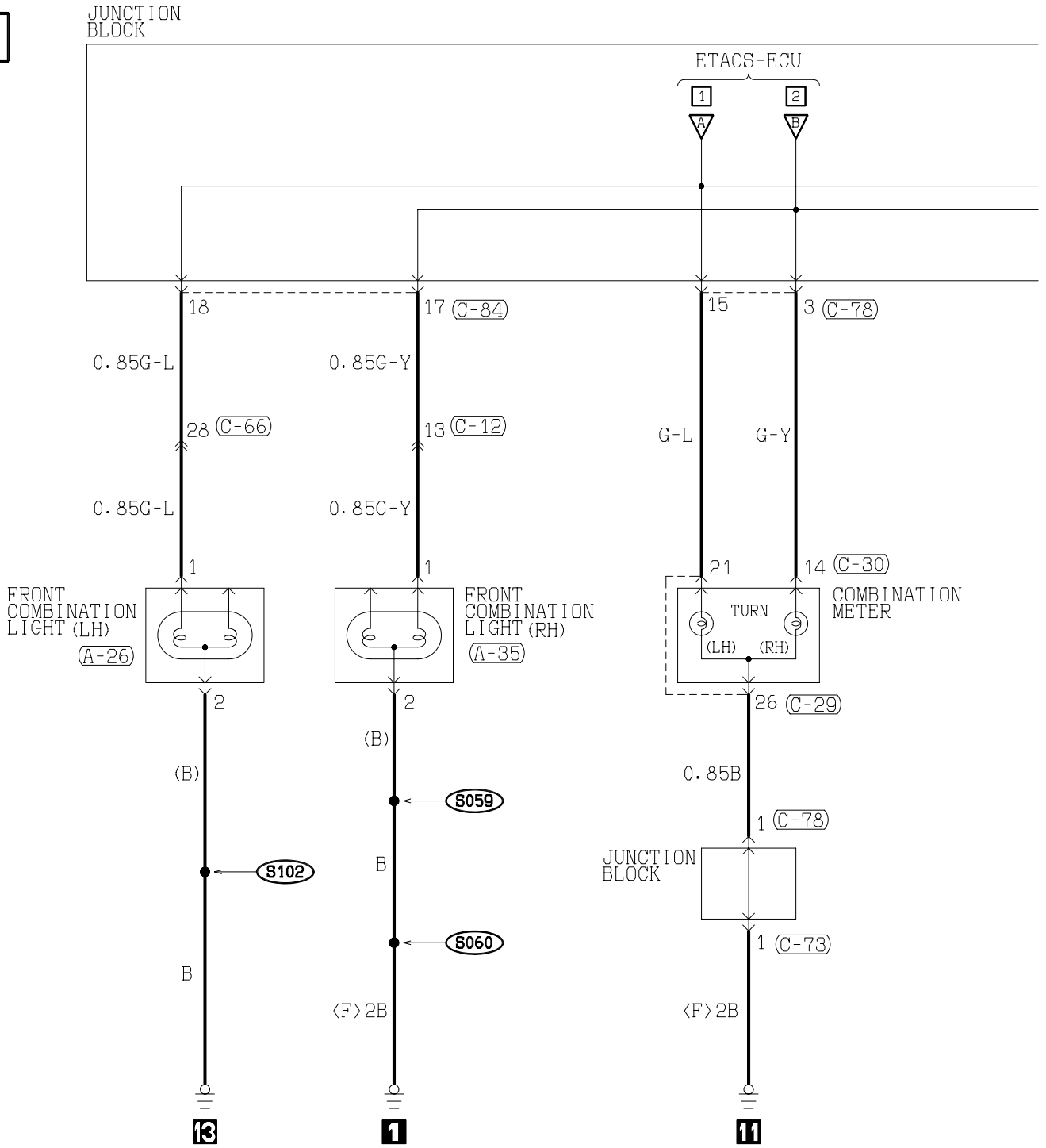

(A-26)



(A-35)



(C-12)

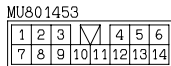

(C-29)

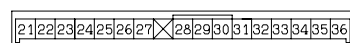

(C-30)

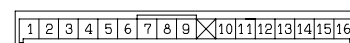

(C-78)

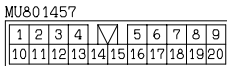

(C-84)

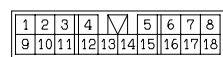

(F-10)



(F-12)



TSB Revision

4

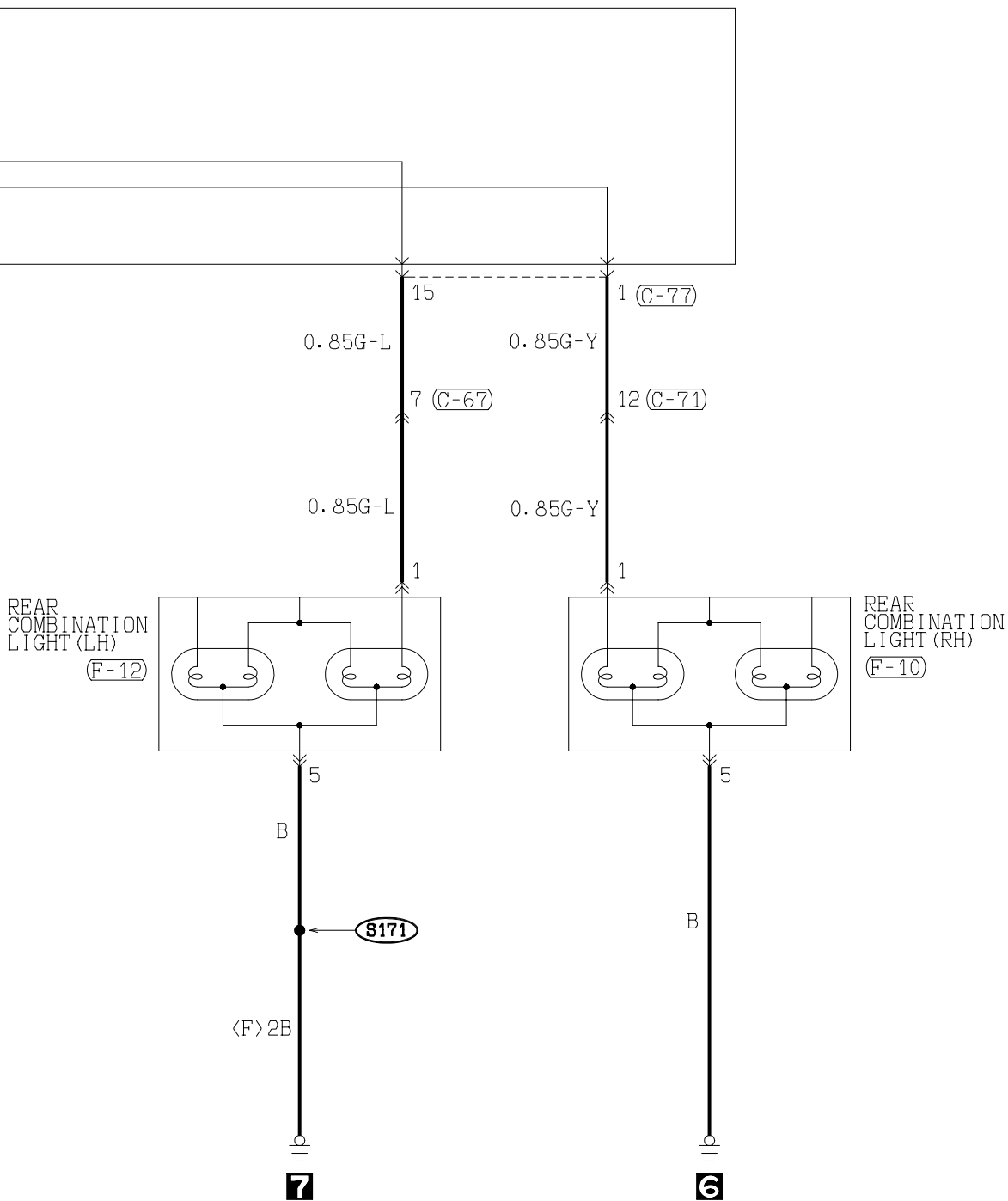

(C-66)

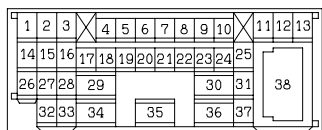

(C-67)

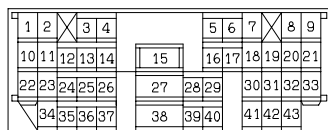

(C-71)

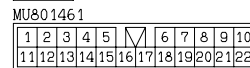

WIRE COLOR CODE
 B : BLACK BR: BROWN
 BL : BLUE LG: LIGHT GREEN
 R : RED SB: SKY BLUE
 Y : YELLOW

(C-73)



(C-77)

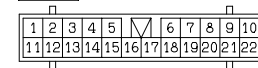

G : GREEN GR: GRAY
 O : ORANGE P : PINK
 V : VIOLET W : WHITE

H1S09M05BB

TSB Revision

STOPLIGHT

1

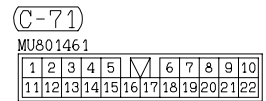
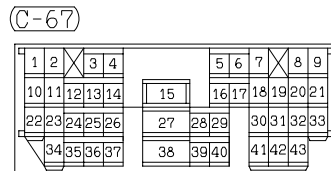
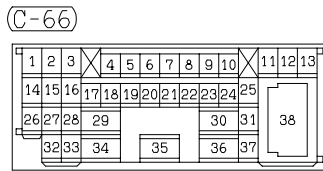
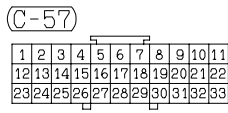
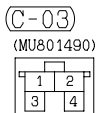
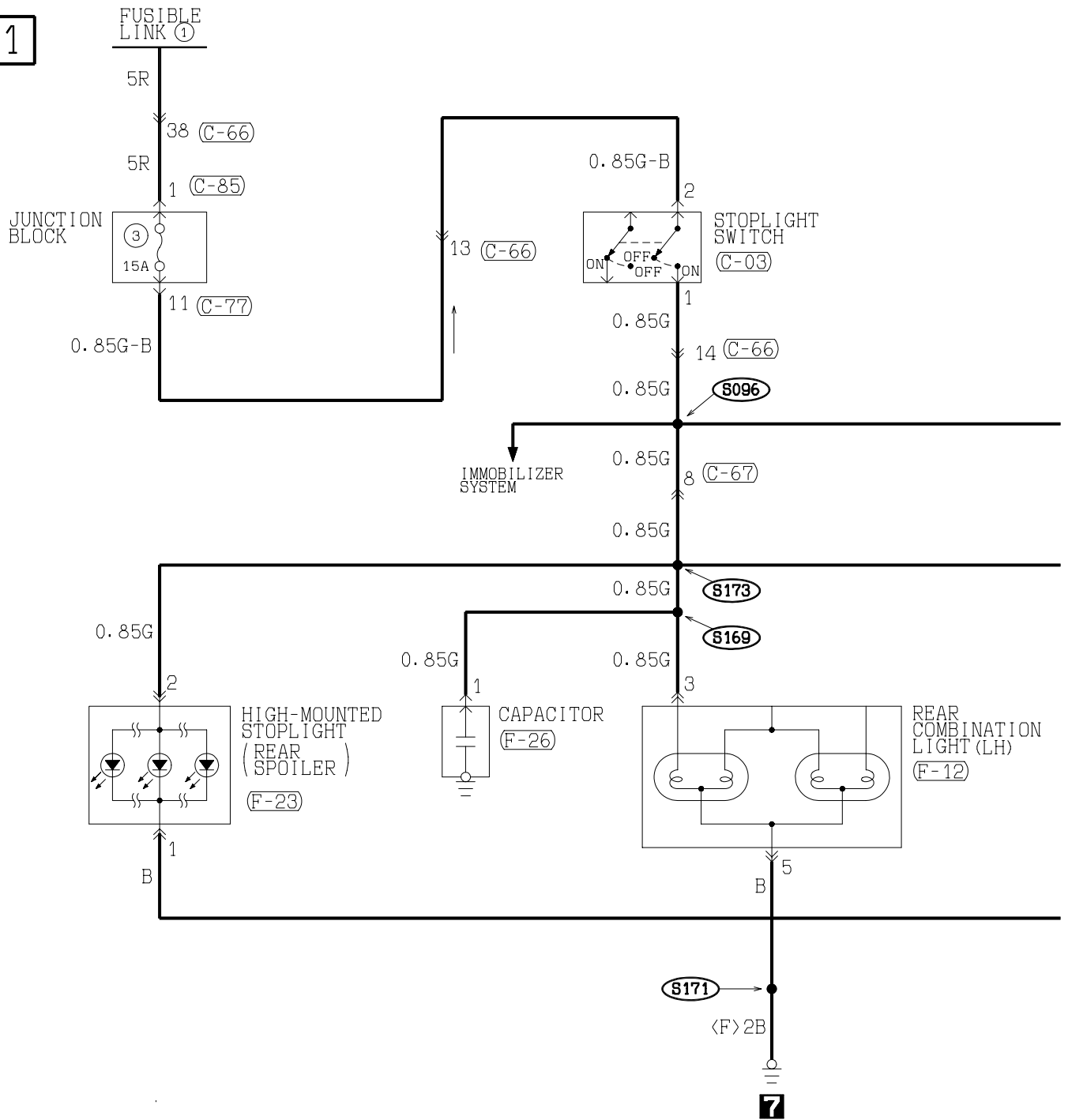

TSB Revision

2

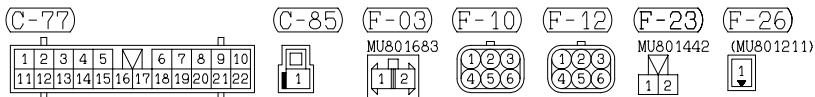
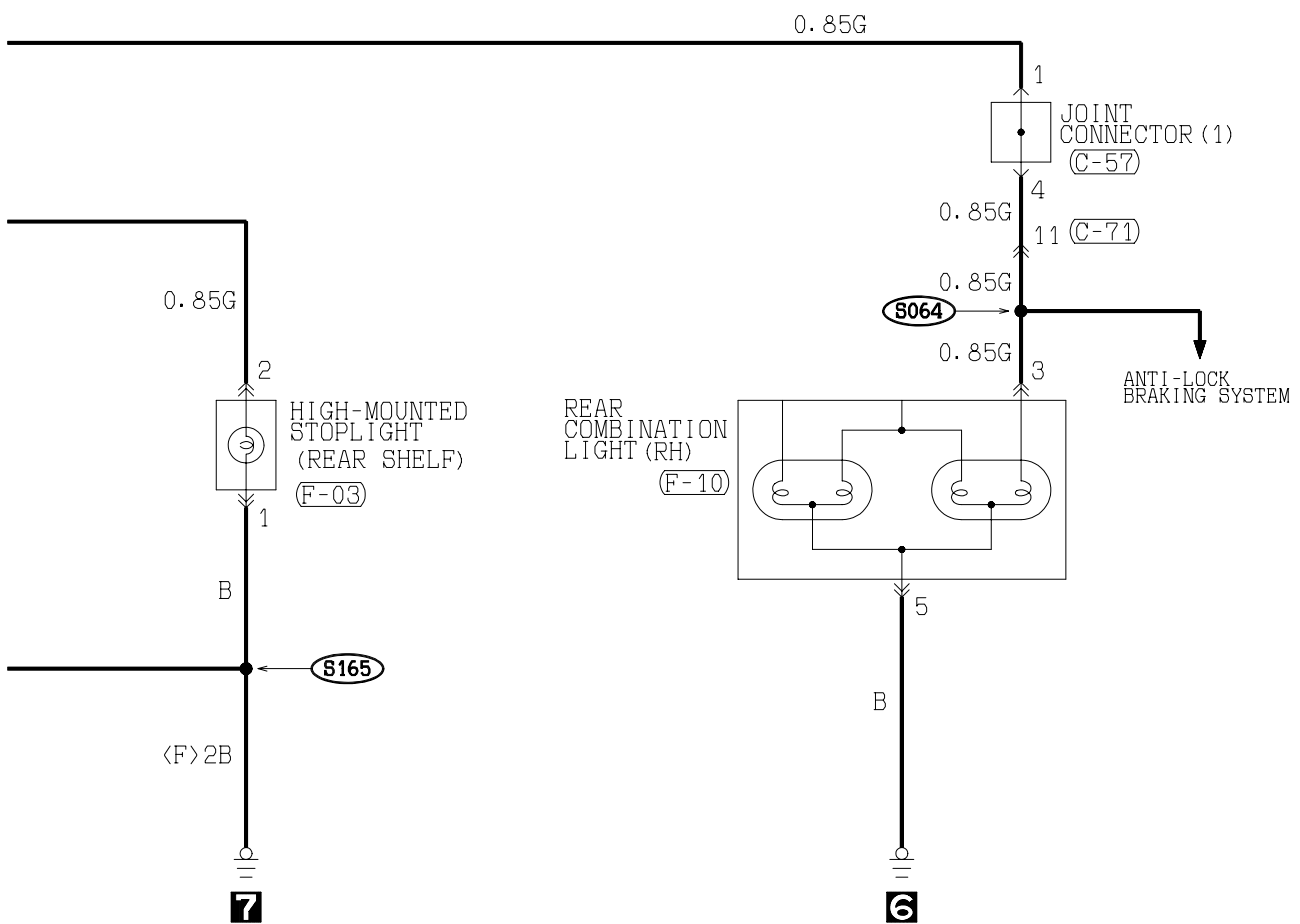

WIRE COLOR CODE
 B : BLACK BR : BROWN G : GREEN GR : GRAY L : BLUE LG : LIGHT GREEN O : ORANGE
 P : PINK R : RED SB : SKY BLUE V : VIOLET W : WHITE Y : YELLOW

H1S09M06AB

TSB Revision

BACKUP LIGHT

1

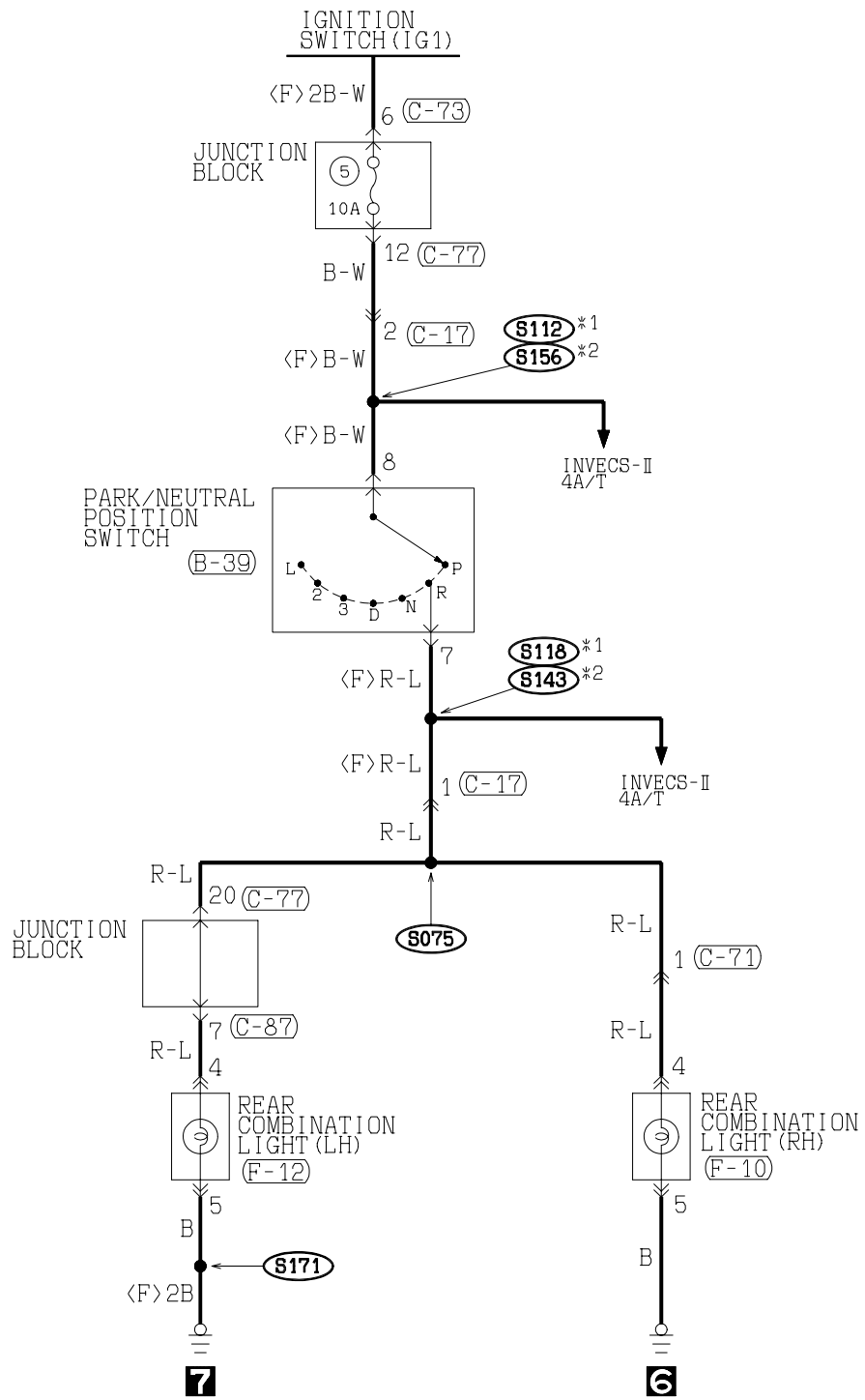

NOTE
*1: 2. 4L ENGINE
*2: 3. 0L ENGINE

(B-39)
MU802355

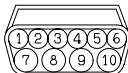

(C-17)

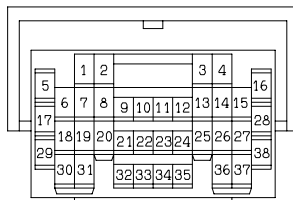

(C-71)
MU801461

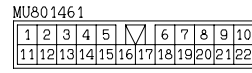

(F-10)



(F-12)



(C-73)
MU801331



(C-77)

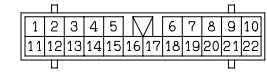

(C-87)

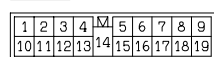

HORN

1

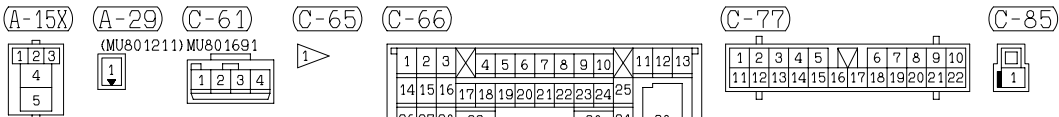
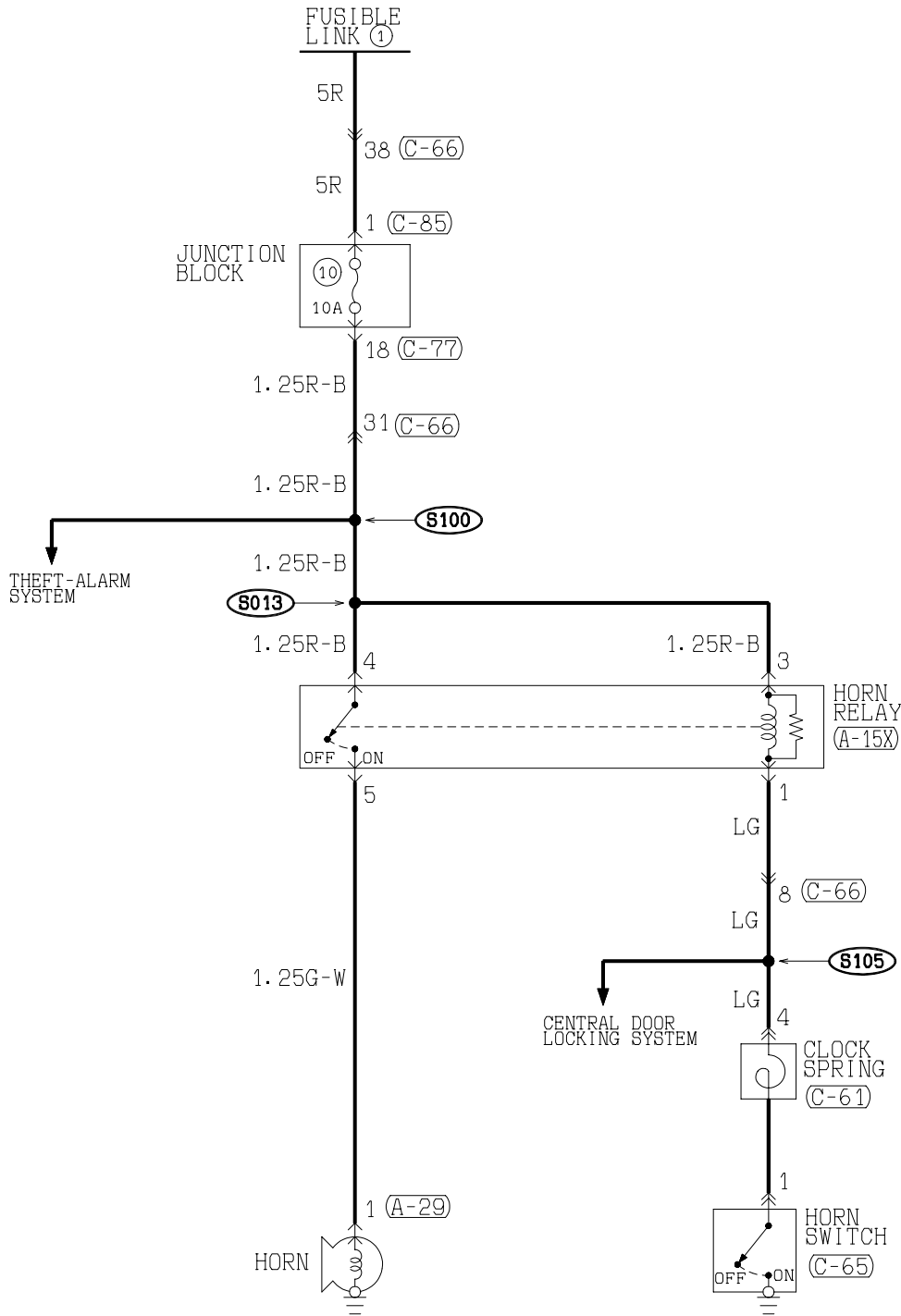

WIRE COLOR CODE
B : BLACK BR : BROWN
P : PINK R : RED

G : GREEN GR : GRAY L : BLUE
SB : SKY BLUE V : VIOLET W : WHITE

LG : LIGHT GREEN O : ORANGE
Y : YELLOW

H1509M08AA

TSB Revision

METER AND GAUGE

M1901003500057

1

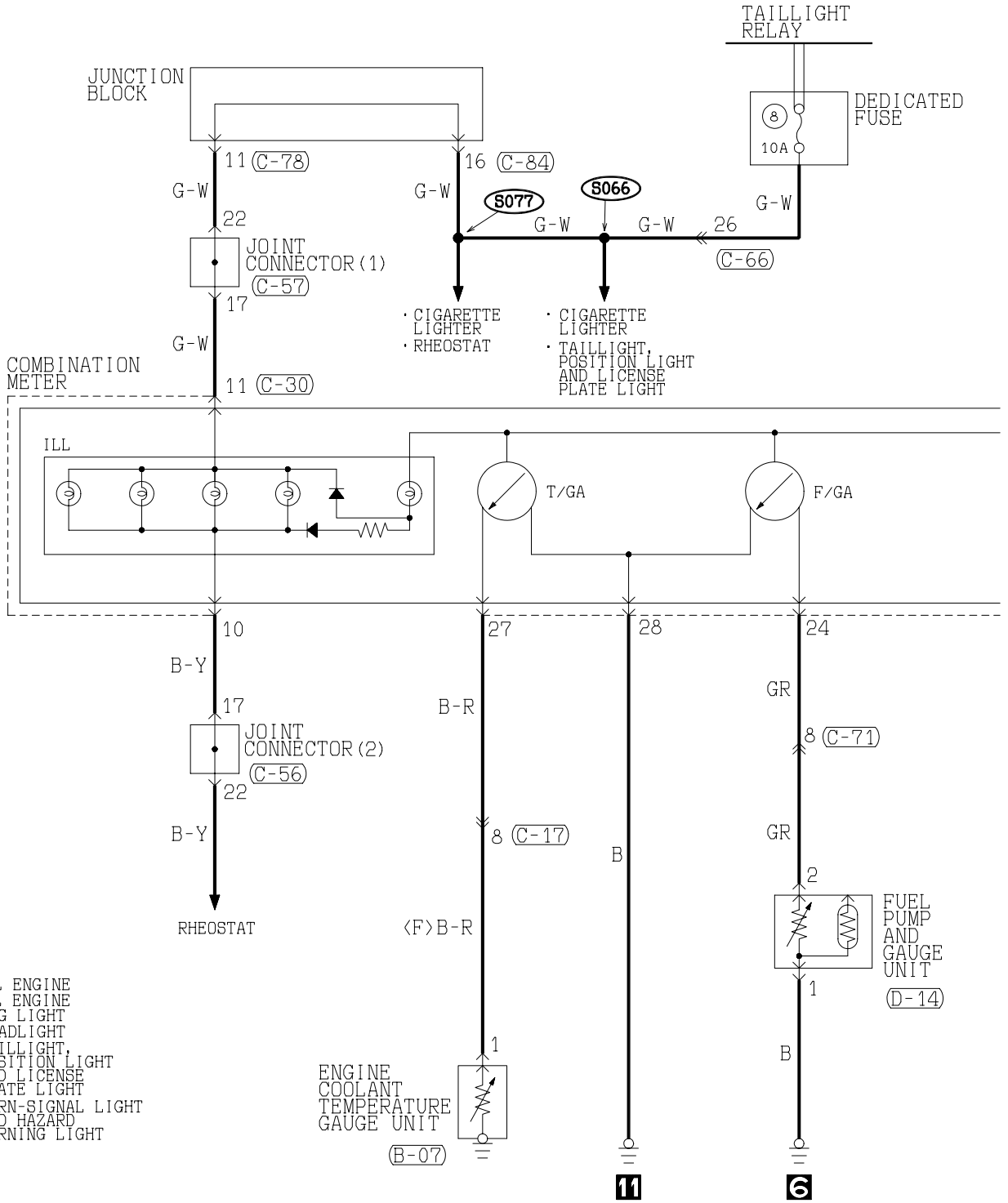

NOTE
 *1: 2.4L ENGINE
 *2: 3.0L ENGINE
 *3: FOG LIGHT
 • HEADLIGHT
 • TAILLIGHT, POSITION LIGHT AND LICENSE PLATE LIGHT
 • TURN-SIGNAL LIGHT AND HAZARD WARNING LIGHT

ENGINE COOLANT TEMPERATURE GAUGE UNIT (B-07)

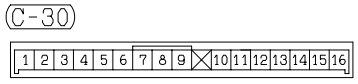
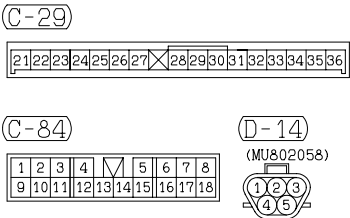
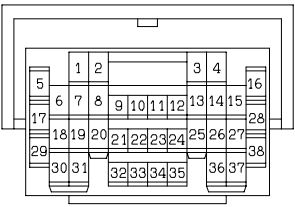
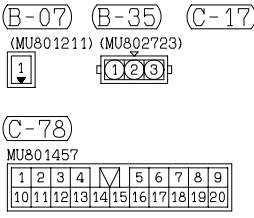

H1S10M02AA

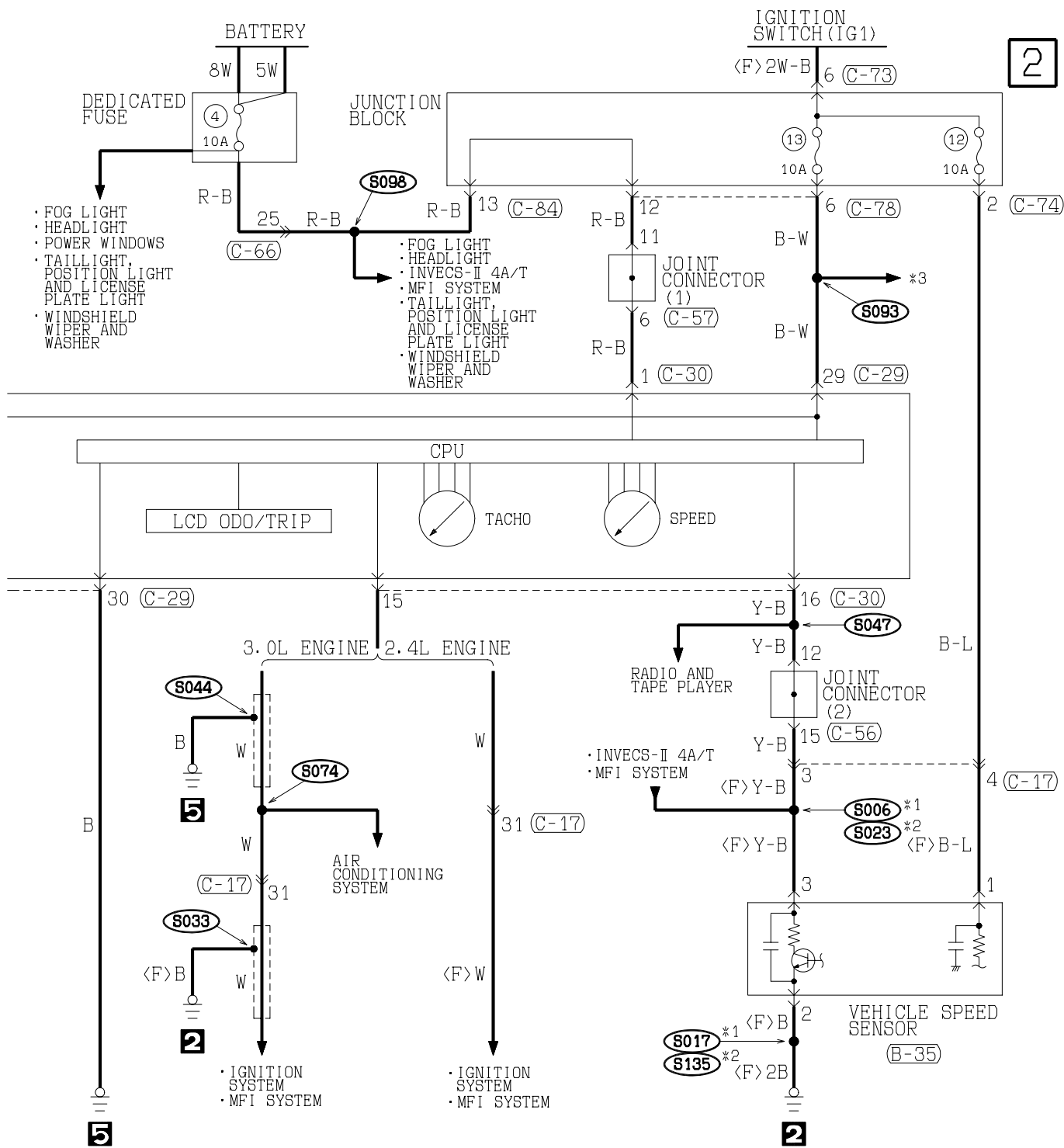

(C-56)

1	2	3	4	5	6	7	8	9	10	11
12	13	14	15	16	17	18	19	20	21	22
23	24	25	26	27	28	29	30	31	32	33

(C-57)

1	2	3	4	5	6	7	8	9	10	11
12	13	14	15	16	17	18	19	20	21	22
23	24	25	26	27	28	29	30	31	32	33

(C-66)

1	2	3	4	5	6	7	8	9	10	11	12	13
14	15	16	17	18	19	20	21	22	23	24	25	38
26	27	28	29	30	31	32	33	34	35	36	37	

(C-71)

1	2	3	4	5	6	7	8	9	10
11	12	13	14	15	16	17	18	19	20
21	22								

(C-73)

1	2	3
4	5	6

(C-74)

1	2	3	4
5	6	7	8
9	10		

WIRE COLOR CODE

B : BLACK BR : BROWN G : GREEN GR : GRAY L : BLUE LG : LIGHT GREEN O : ORANGE
P : PINK R : RED SB : SKY BLUE V : VIOLET W : WHITE Y : YELLOW

H1S10M02AB

TSB Revision

BRAKE WARNING LIGHT, OIL PRESSURE WARNING LIGHT, FUEL WARNING LIGHT

M1901011800053

1

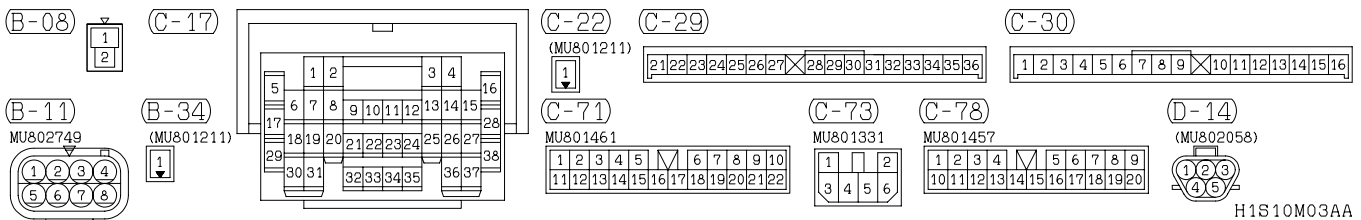
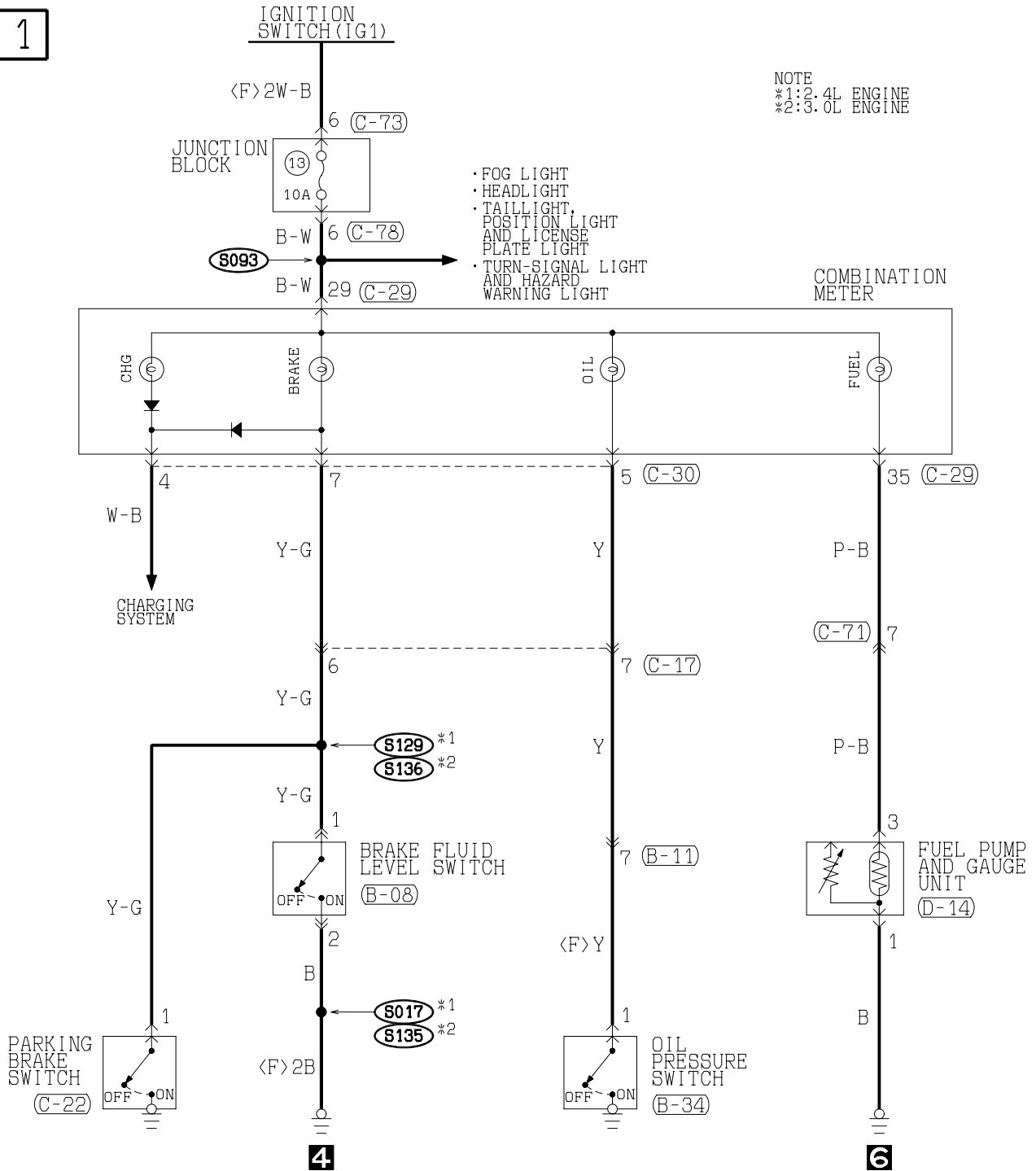

H1S10M03AA

TSB Revision

NOTES

TSB Revision

POWER WINDOWS

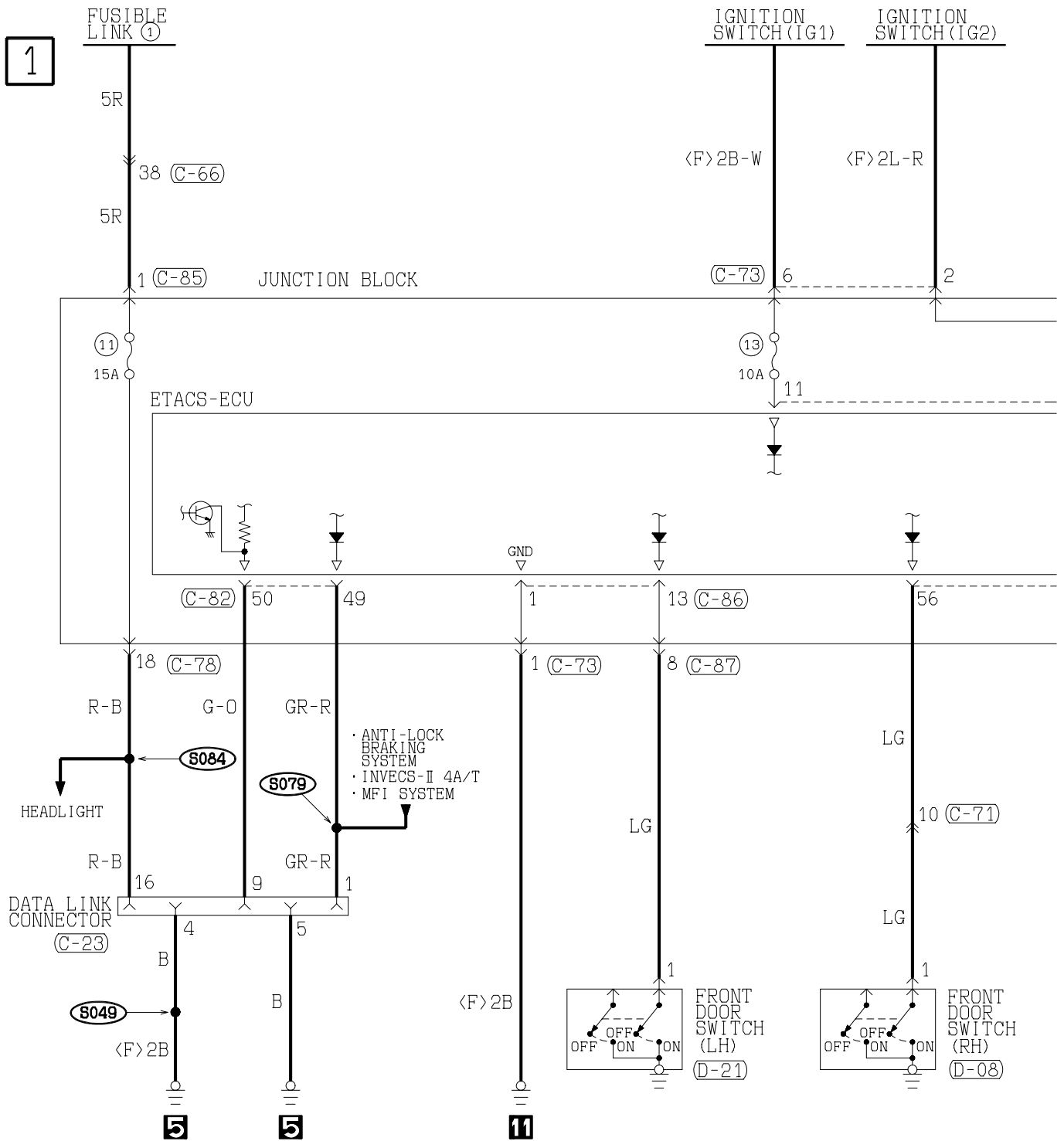

(A-04X)



(A-09X)

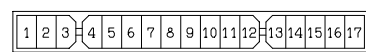

(C-23) FRONT SIDE

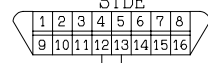

(C-66)

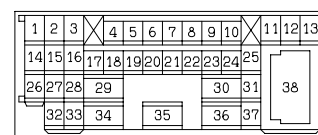

(C-67)

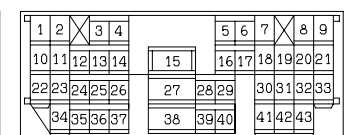

(C-86)

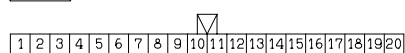

(C-87)

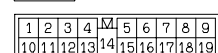

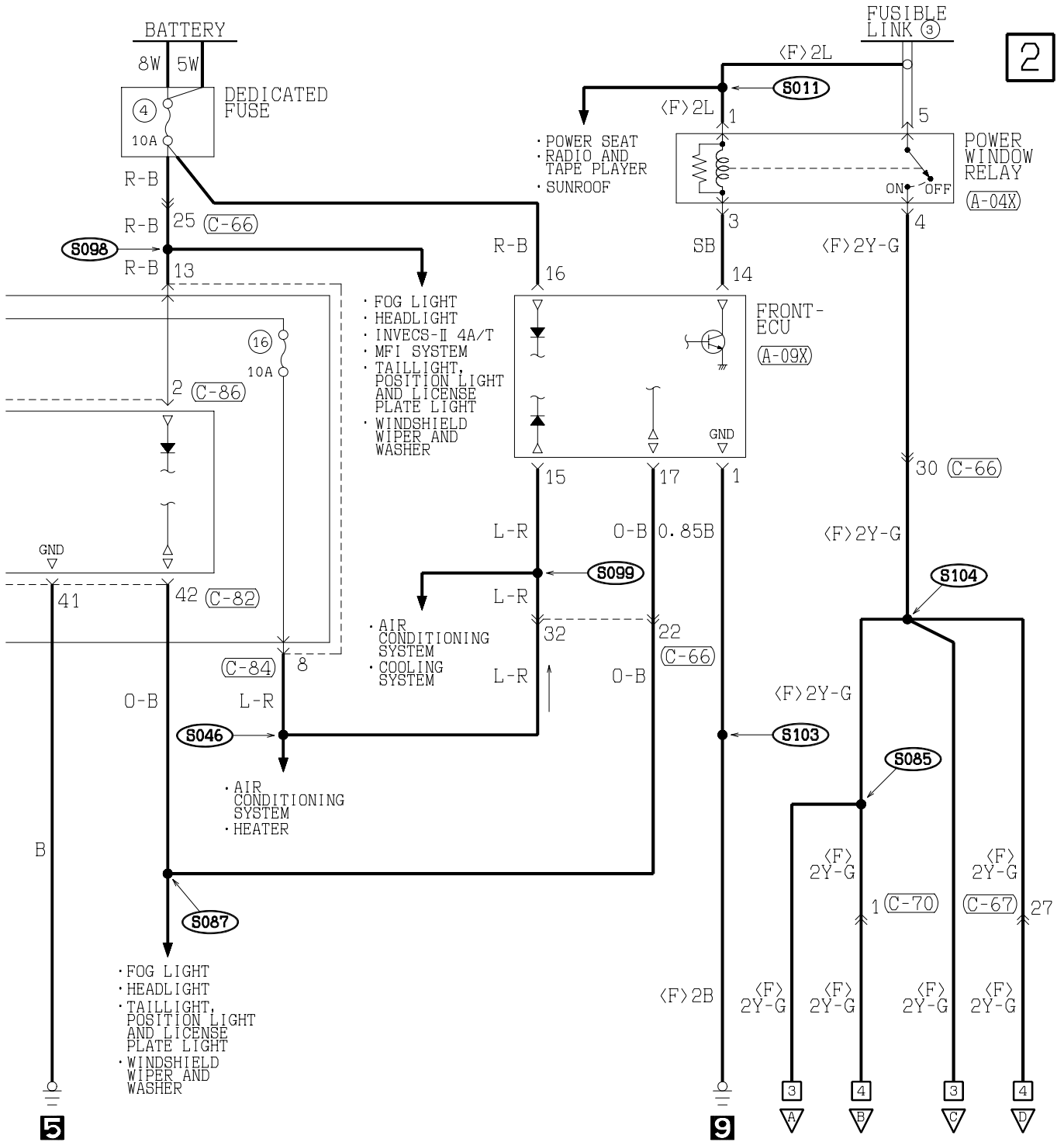

(C-70) MU801329



(C-71) MU801461

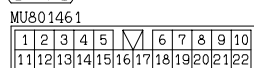

(C-73) MU801331



(C-78) MU801457

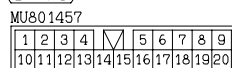

(C-82) (MU801584)

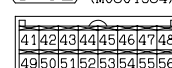

(C-84)

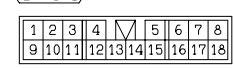

(C-85)



WIRE COLOR CODE
B : BLACK BR : BROWN
P : PINK R : RED

G : GREEN GR : GRAY
SB : SKY BLUE V : VIOLET

L : BLUE LG : LIGHT GREEN
Y : YELLOW

O : ORANGE

H1S11M02AB

POWER WINDOWS (CONTINUED)

3

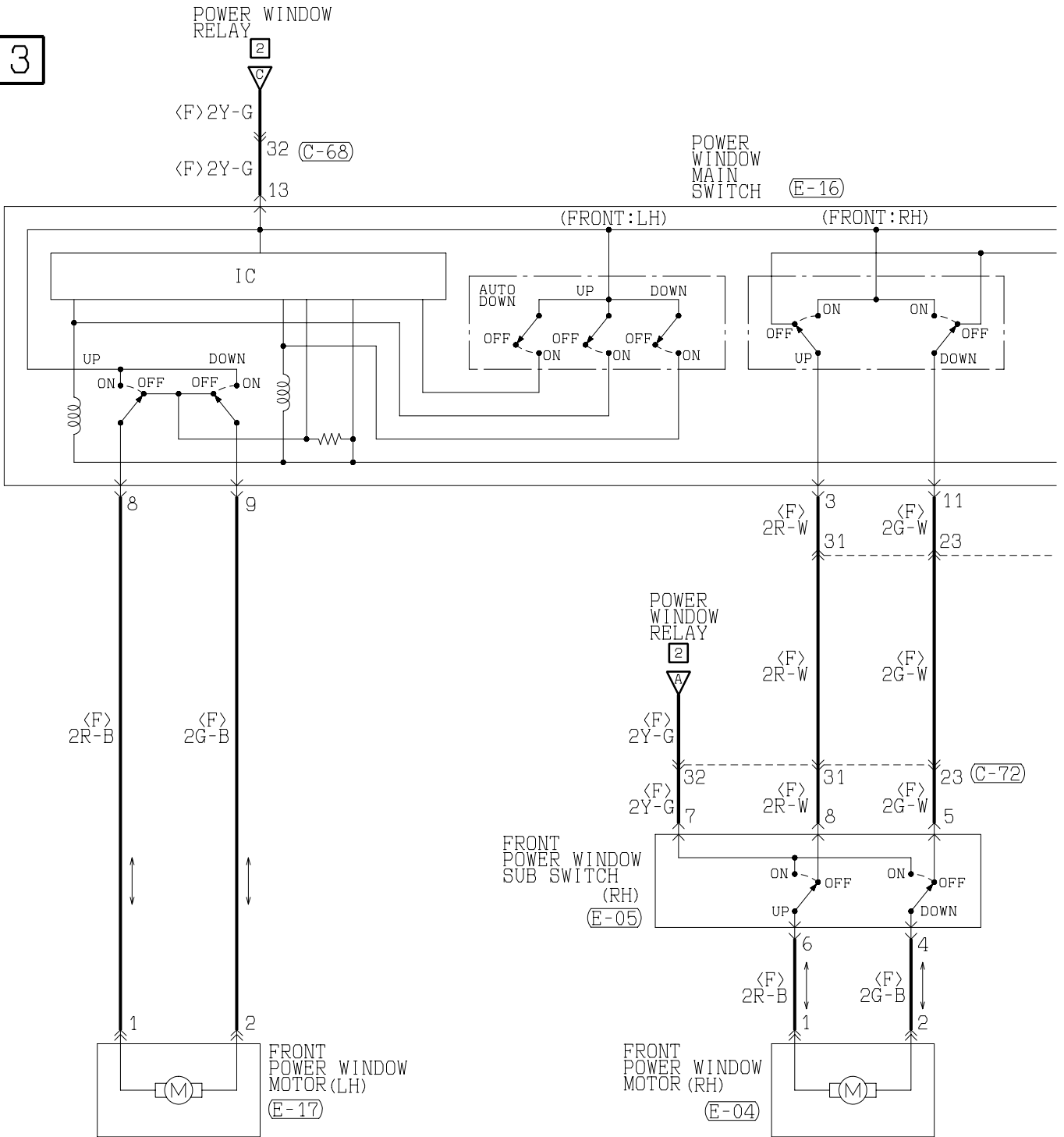

C-67

1	2	3	4		5	6	7	8	9		
10	11	12	13	14	15	16	17	18	19	20	21
22	23	24	25	26	27	28	29	30	31	32	33
34	35	36	37		38	39	40	41	42	43	

C-68

1	2	3	4	5	6	7	8	9			
10	11	12	13	14	15	16	17	18	19	20	21
22	23	24	25	26	27	28	29	30	31	32	

C-70

MU801329

1	2
3	4

C-72

1	2	3	4	5	6	7	8	9			
10	11	12	13	14	15	16	17	18	19	20	21
22	23	24	25	26	27	28	29	30	31	32	

D-07

MU801451

1	2	3	4		
5	6	7	8	9	10

D-19

1	2	3	4		
5	6	7	8	9	10

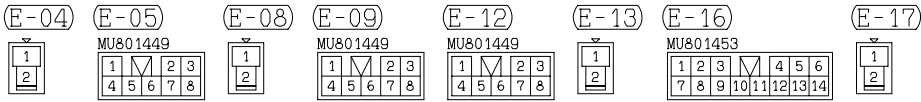
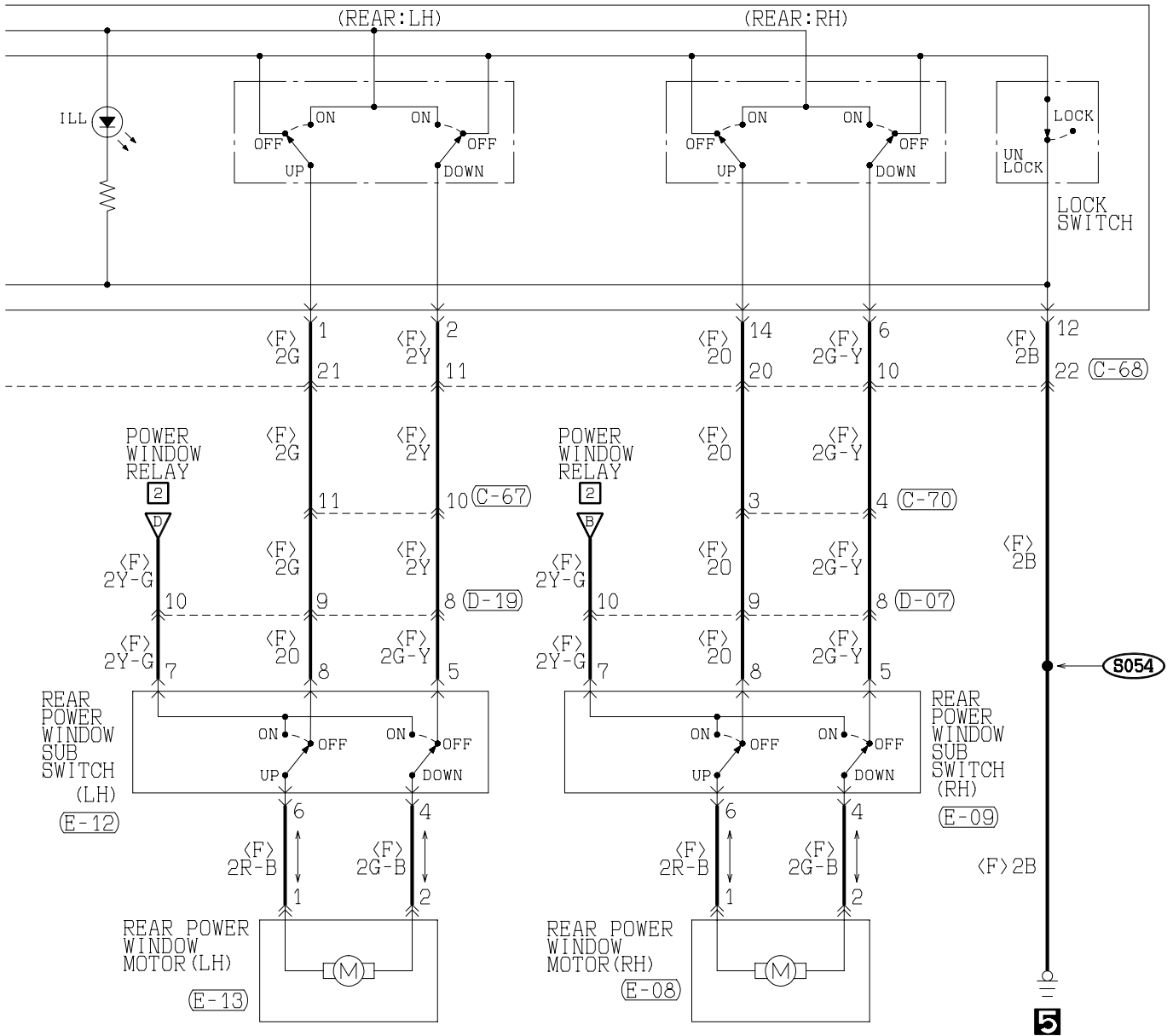

WIRE COLOR CODE
 B : BLACK BR : BROWN G : GREEN GR : GRAY L : BLUE LG : LIGHT GREEN O : ORANGE
 P : PINK R : RED SB : SKY BLUE V : VIOLET W : WHITE Y : YELLOW

H1S11M02BB

CENTRAL DOOR LOCKING SYSTEM

M1901004700087

1

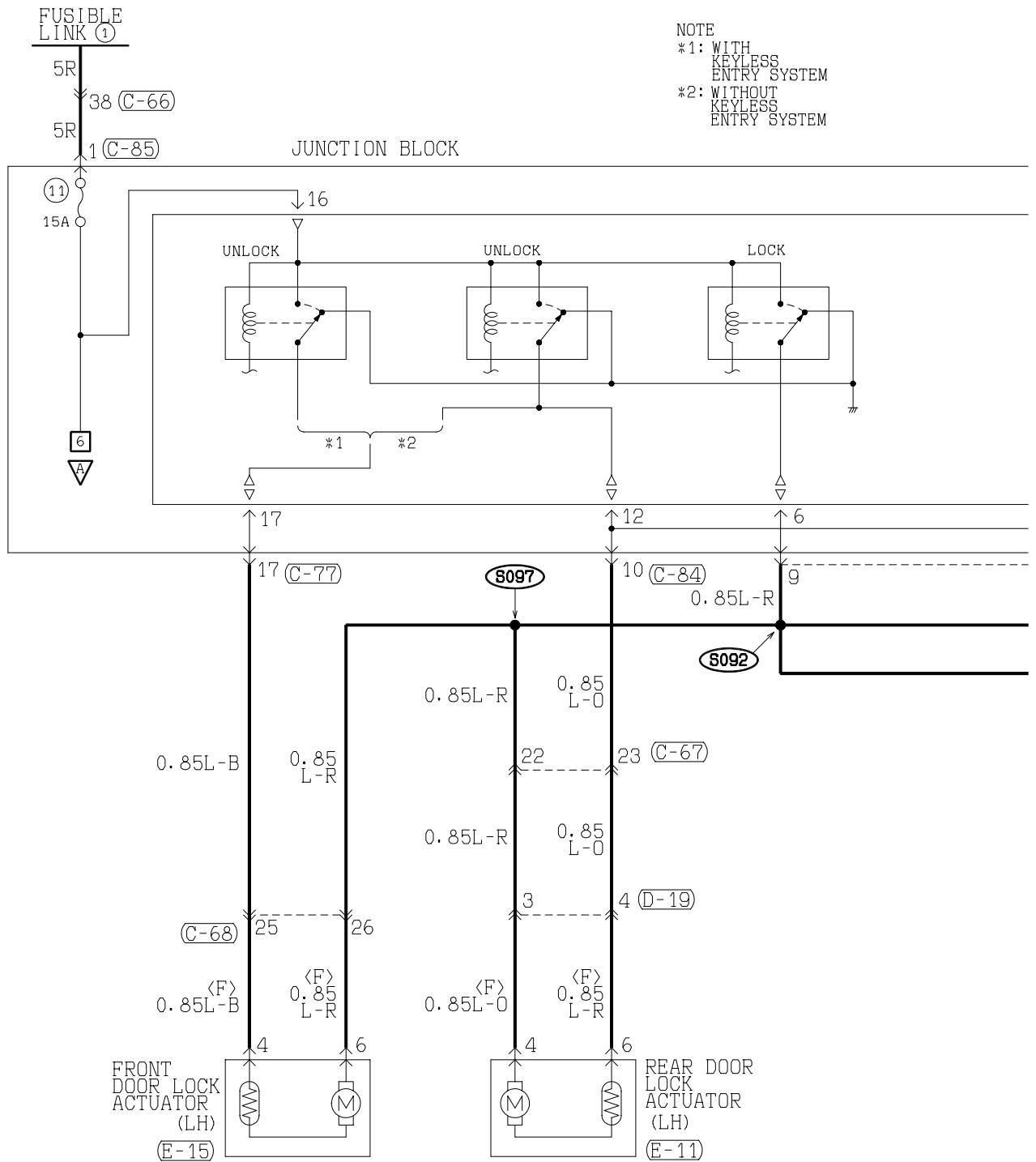

C-66

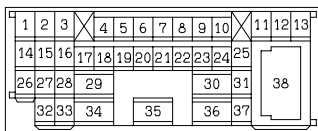

C-67

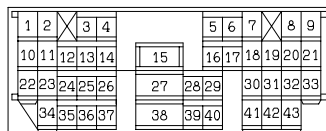

C-68

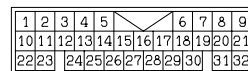

C-71

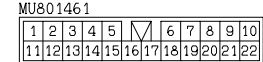

C-86

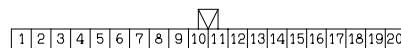

D-07

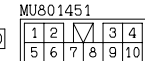

H1S11M03AA

TSB Revision

2

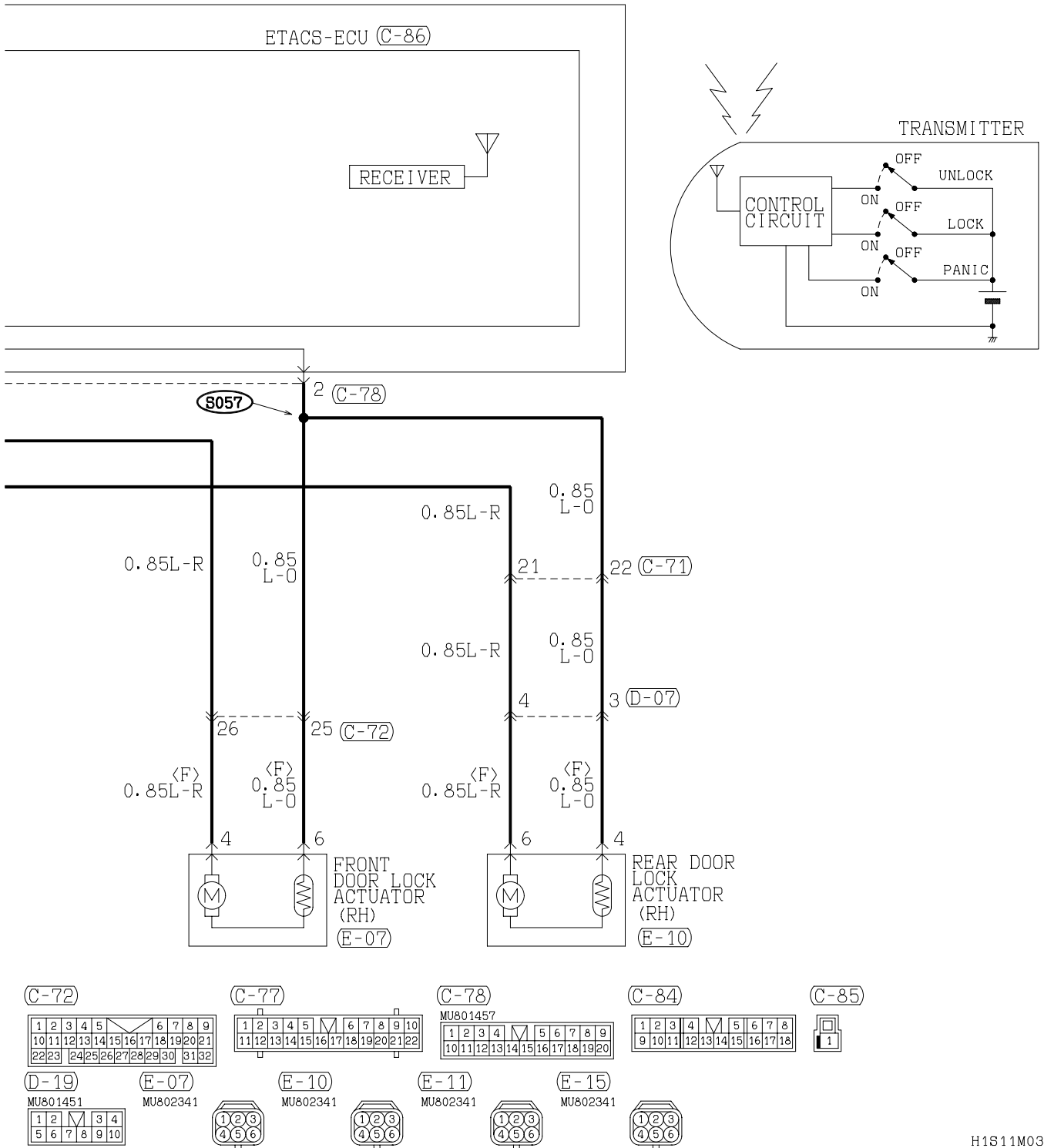

H1S11M03AB

TSB Revision

CENTRAL DOOR LOCKING SYSTEM (CONTINUED)

3 JUNCTION
BLOCK

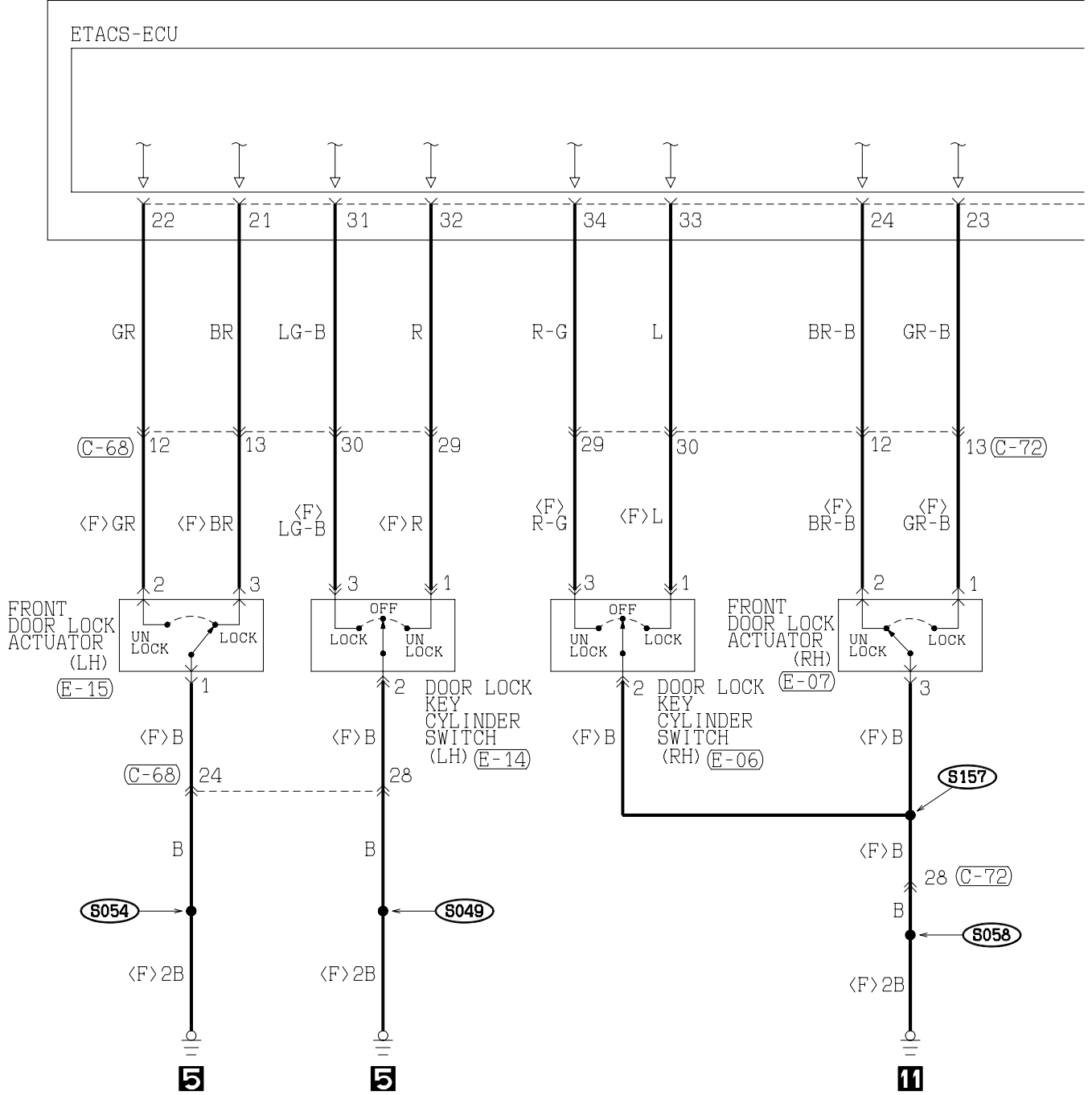

(C-59) MU801547

1	2	3	4	5	6	7	8	9
10	11	12	13	14	15	16	17	18
19	20	21	22	23	24	25	26	27
28	29	30	31	32				

(C-68)

1	2	3	4	5	6	7	8	9
10	11	12	13	14	15	16	17	18
19	20	21	22	23	24	25	26	27
28	29	30	31	32				

(C-72)

1	2	3	4	5	6	7	8	9
10	11	12	13	14	15	16	17	18
19	20	21	22	23	24	25	26	27
28	29	30	31	32				

(C-81) (MU801585)

1	2	3	4	5	6	7	8	9
10	11	12	13	14	15	16	17	18
19	20	21	22	23	24	25	26	27
28	29	30	31	32	33	34	35	36
37	38	39	40					

(C-82) (MU801584)

1	2	3	4	5	6	7	8
9	10	11	12	13	14	15	16
17	18	19	20	21	22	23	24
25	26	27	28	29	30	31	32
33	34	35	36	37	38	39	40
41	42	43	44	45	46	47	48
49	50	51	52	53	54	55	56

(E-05) MU801449

1	2	3	4	5	6	7	8

4

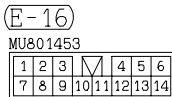
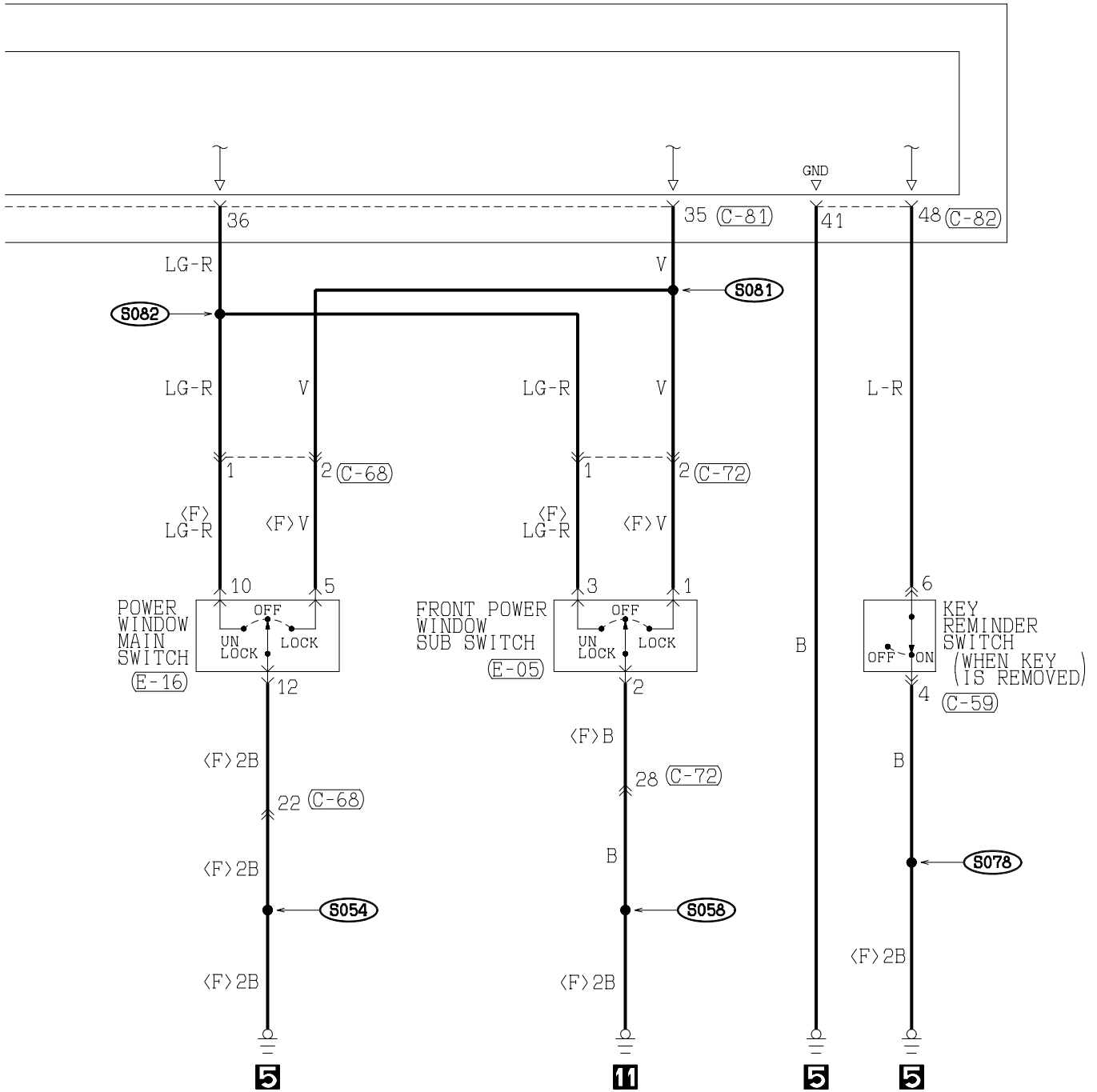

WIRE COLOR CODE
 B : BLACK BR : BROWN G : GREEN GR : GRAY L : BLUE LG : LIGHT GREEN O : ORANGE
 P : PINK R : RED SB : SKY BLUE V : VIOLET W : WHITE Y : YELLOW

H1S11M03BB

TSB Revision

CENTRAL DOOR LOCKING SYSTEM (CONTINUED)

5

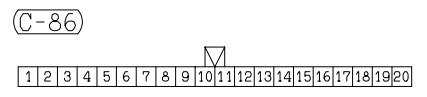
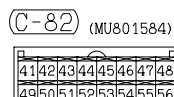
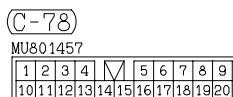
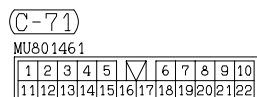
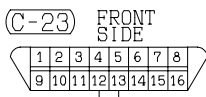
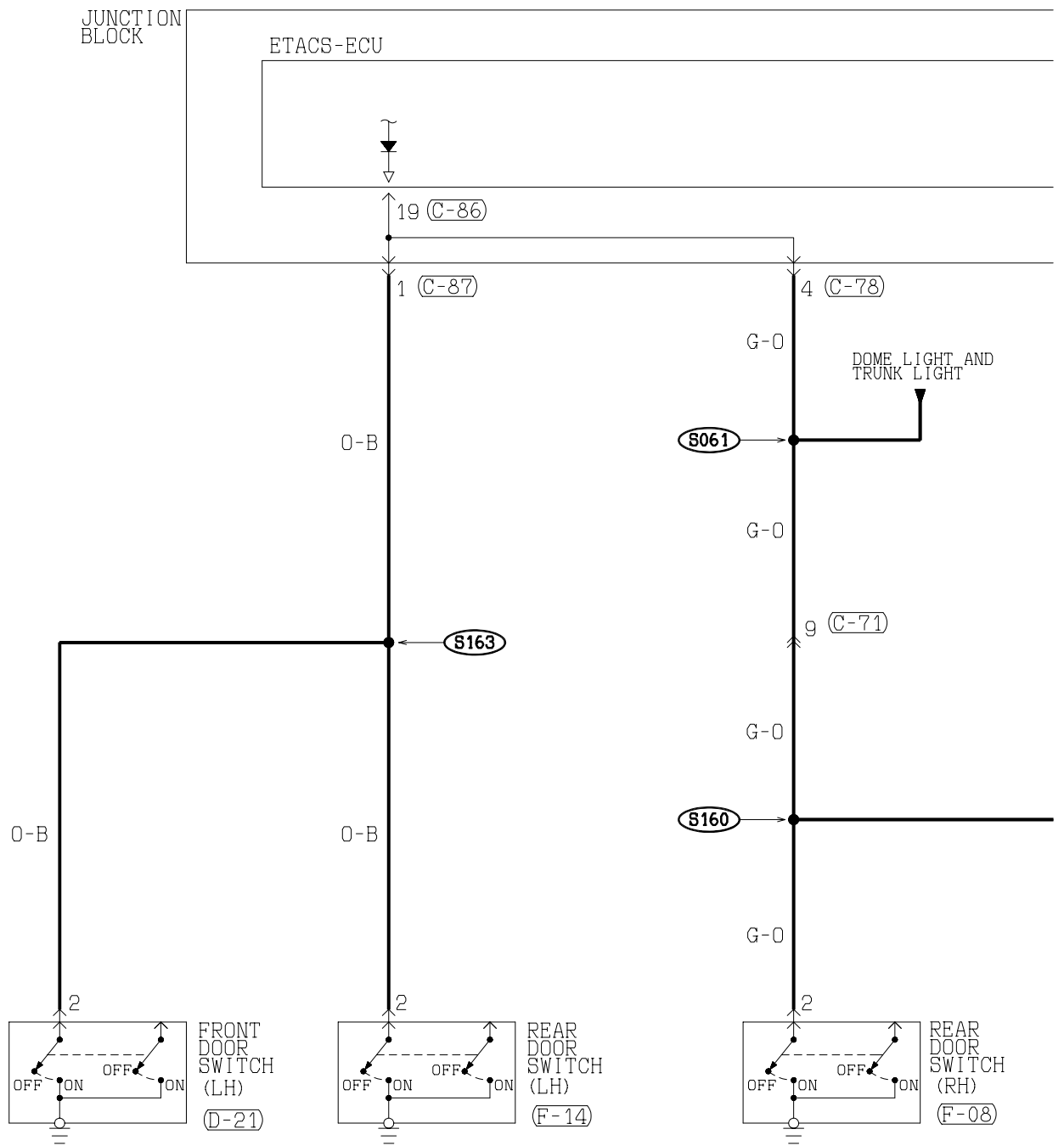

6

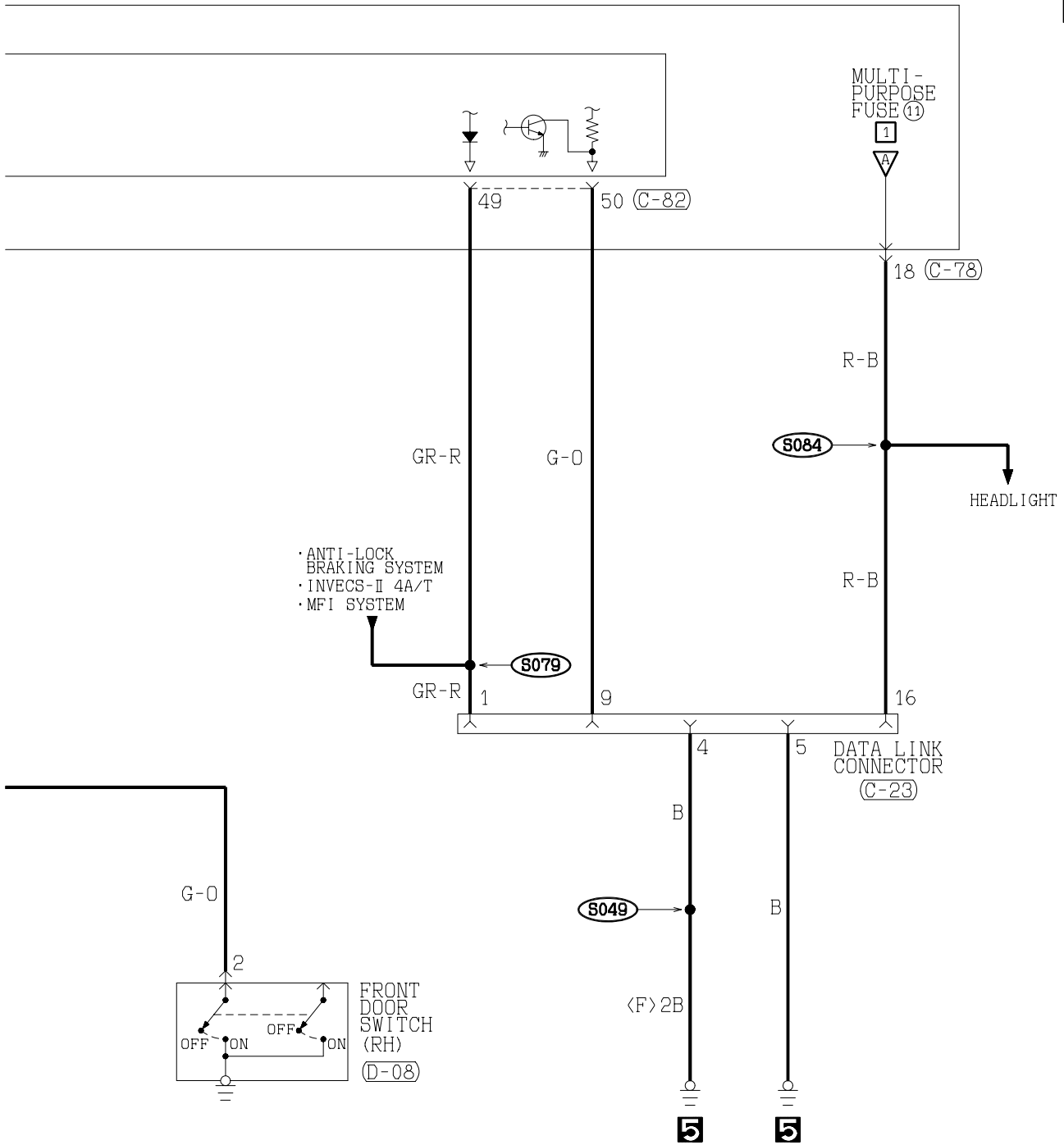

(C-87)

1	2	3	4	5	6	7	8	9	
10	11	12	13	14	15	16	17	18	19

(D-08)

1	2	3
---	---	---

(D-21)

1	2	3
---	---	---

(F-08)

1	2	3
---	---	---

(F-14)

1	2	3
---	---	---

WIRE COLOR CODE
 B : BLACK BR : BROWN G : GREEN GR : GRAY L : BLUE LG : LIGHT GREEN O : ORANGE
 P : PINK R : RED SB : SKY BLUE V : VIOLET W : WHITE Y : YELLOW

H1S11M03CB

TSB Revision

CENTRAL DOOR LOCKING SYSTEM (CONTINUED)

7

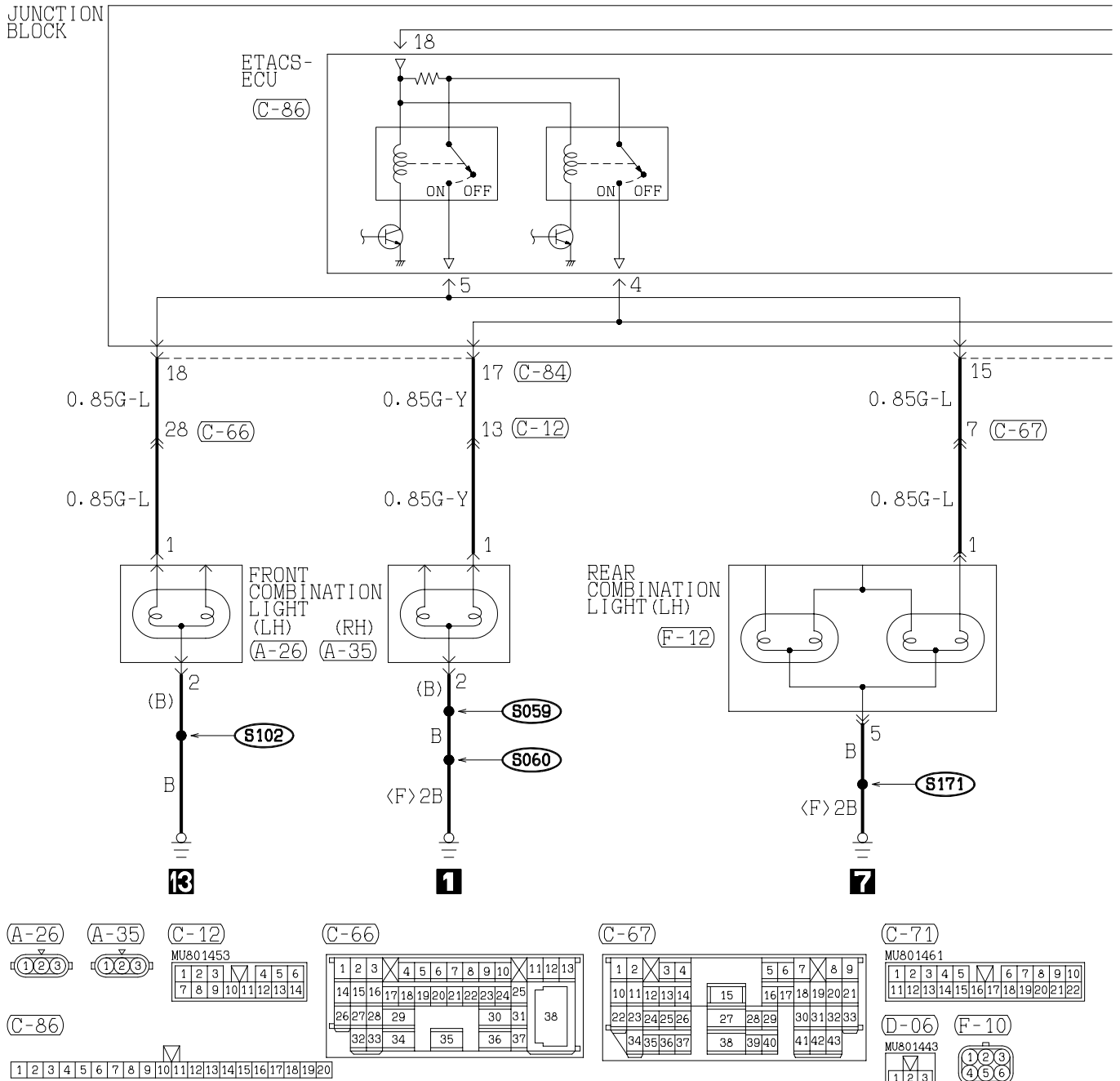

H1S11M03DA

TSB Revision

8

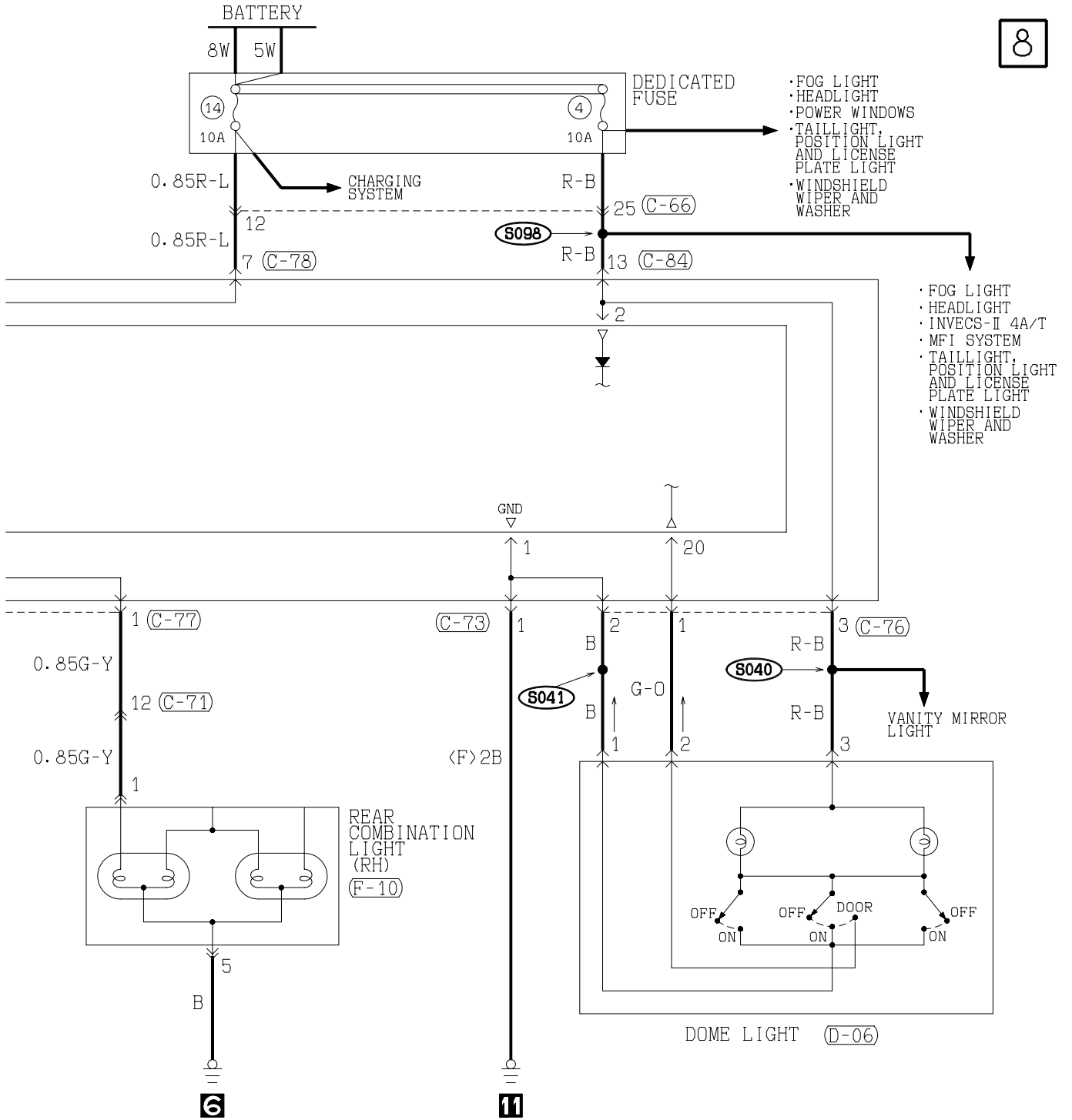

(C-73)
MU801331

1		2
3	4	5

(C-76)
MU801447

1	M	2
3	4	5

(C-77)
MU801457

1	2	3	4	5	M	6	7	8	9	10	
11	12	13	14	15	16	17	18	19	20	21	22

(C-78)
MU801457

1	2	3	4	M	5	6	7	8	9	
10	11	12	13	14	15	16	17	18	19	20

(C-84)

1	2	3	4	M	5	6	7	8	
9	10	11	12	13	14	15	16	17	18

(F-12)

1	2	3
4	5	6

WIRE COLOR CODE
 B : BLACK BR : BROWN G : GREEN GR : GRAY L : BLUE LG : LIGHT GREEN O : ORANGE
 P : PINK R : RED SB : SKY BLUE V : VIOLET W : WHITE Y : YELLOW

H1S11M03DB

TSB Revision

CENTRAL DOOR LOCKING SYSTEM (CONTINUED)

<VEHICLES WITHOUT THEFT-ALARM SYSTEM>

9

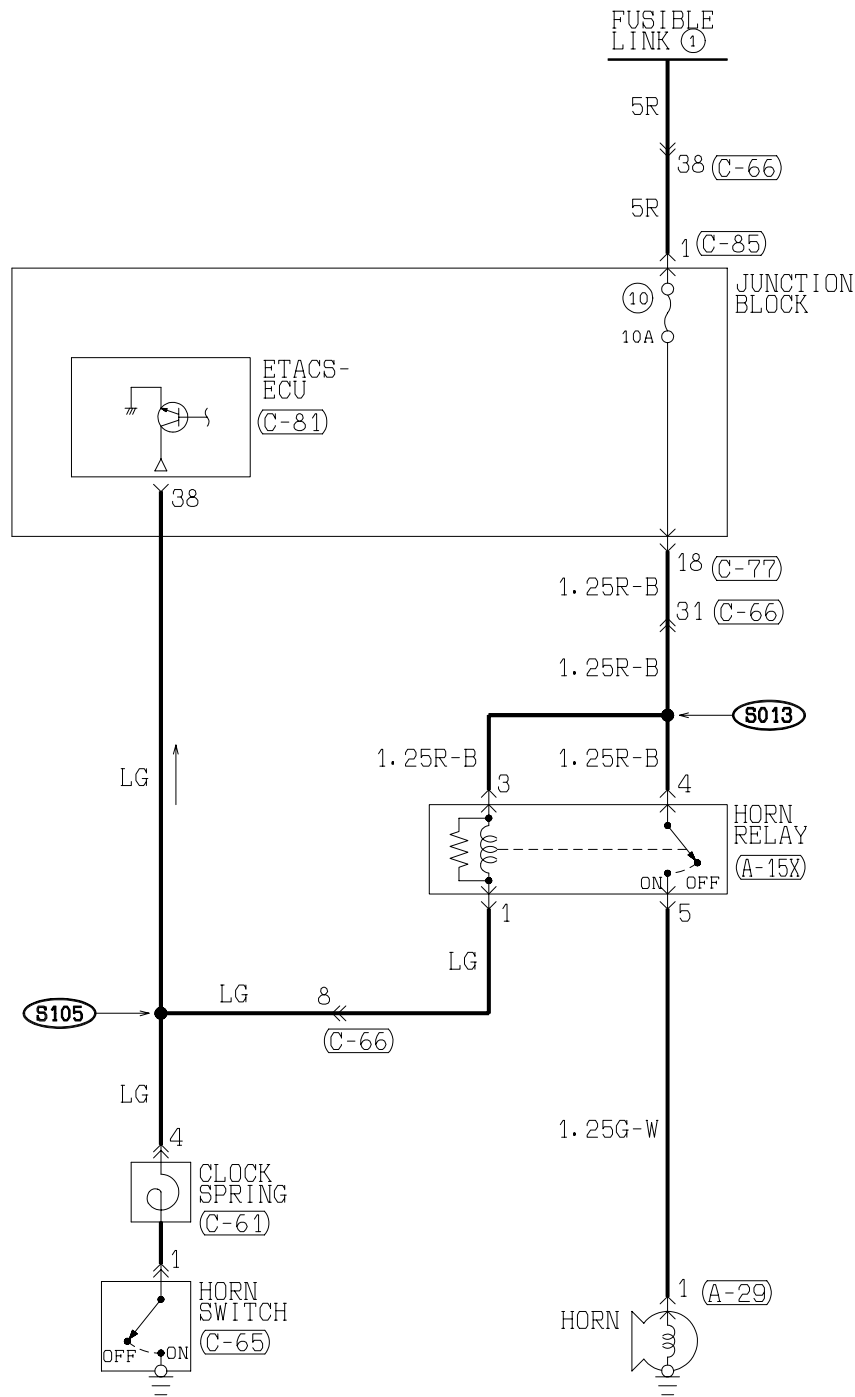

(A-11X)

(A-15X)

(A-23)

(A-29)

(C-61)

(C-65)

(C-66)

(C-77)

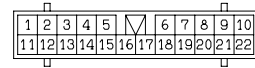
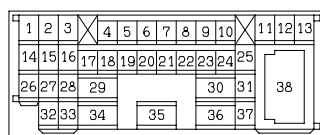

TSB Revision

<VEHICLES WITH THEFT-ALARM SYSTEM>

10

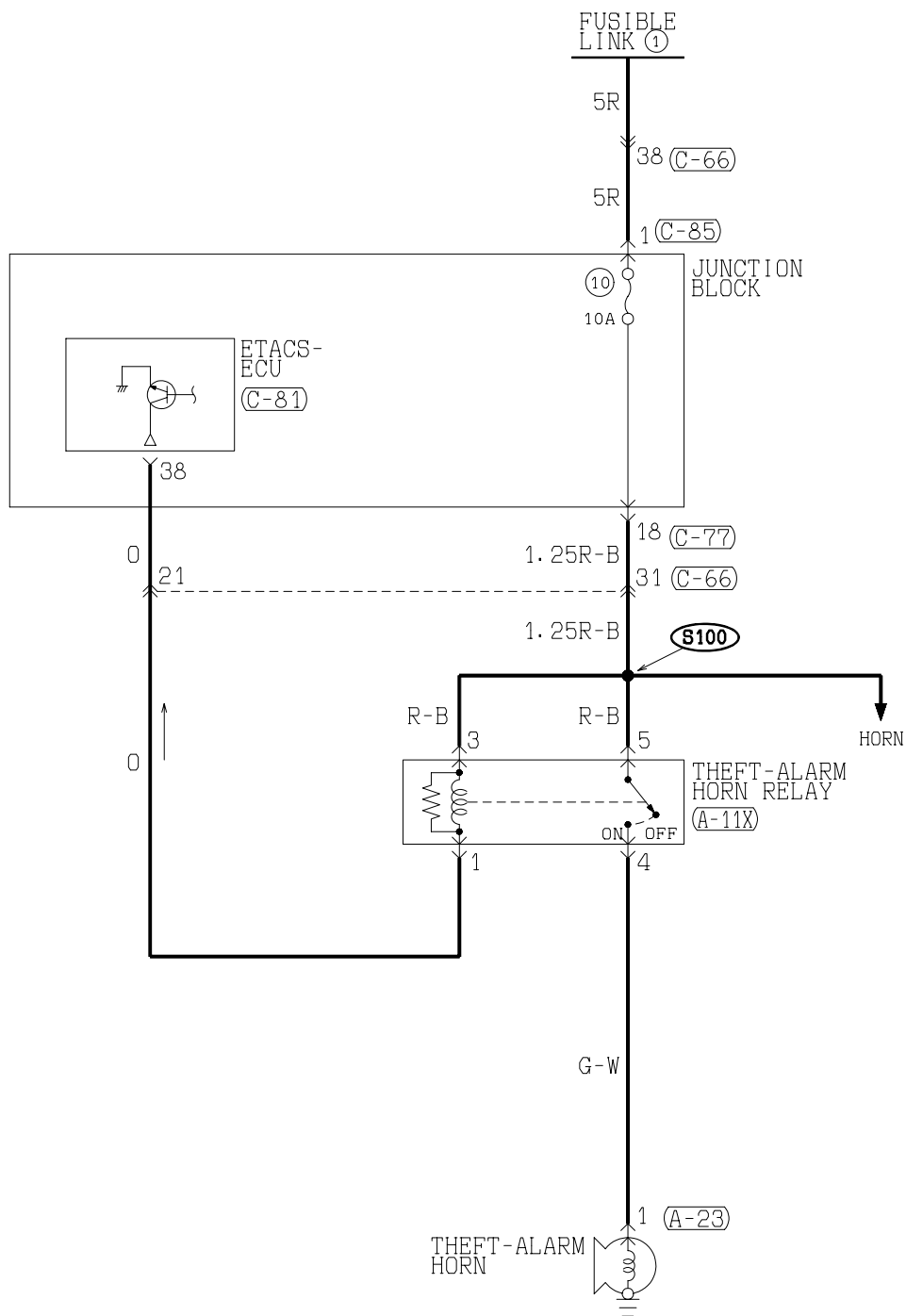

(C-81) (MU801585)

(C-85)

21	22	23	24	25	26	27	28	29	30
31	32	33	34	35	36	37	38	39	40



Wire color	code	G :Green	L :Blue	W :White	Y :Yellow	SB:Sky blue
B :Black	LG:Light green	GR:Gray	R :Red	P :Pink	V :Violet	
BR:Brown	O :Orange					

H1S11M03EB

TSB Revision

HEATER

1

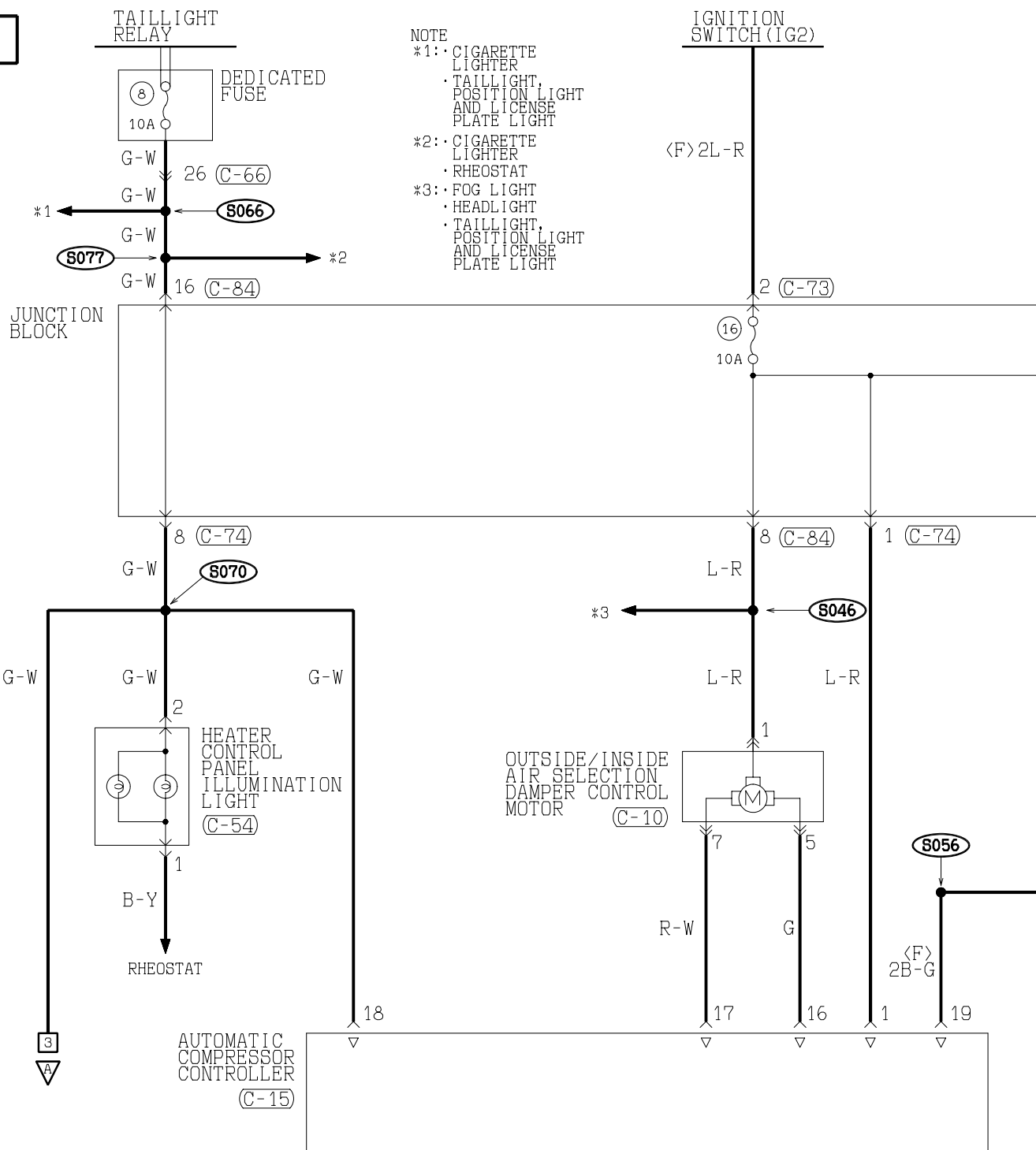

(C-10)

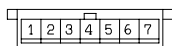

(C-11)



(C-14)



(C-15) (MU801585)

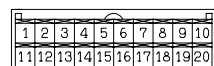

(C-53)



(C-54)



(C-66)

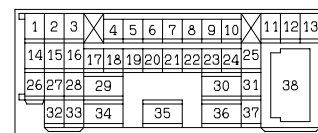

(C-73)



TSB Revision

2

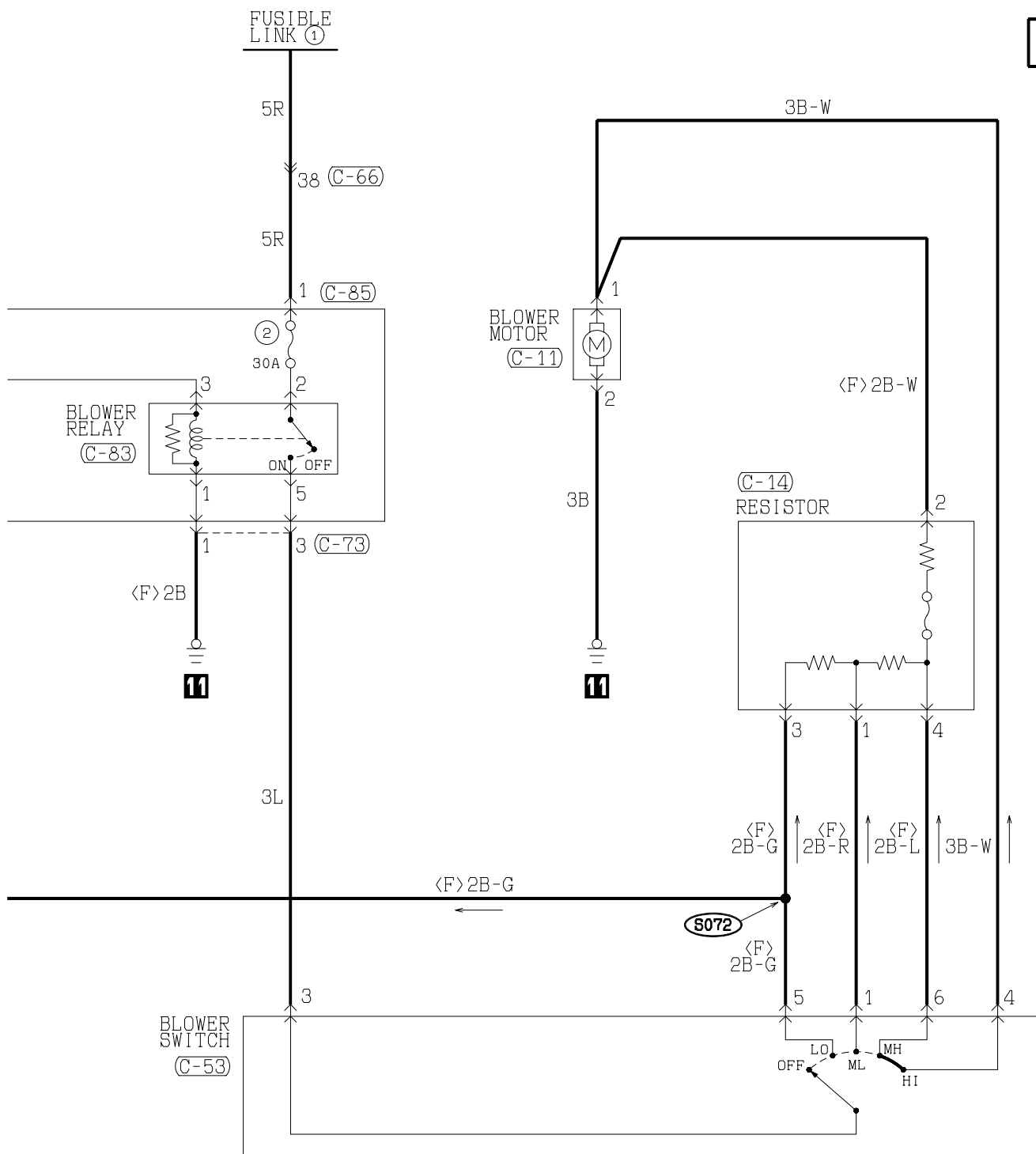

(C-74)

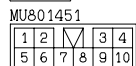

(C-83)



(C-84)

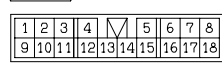

(C-85)



WIRE COLOR CODE

B : BLACK BR : BROWN G : GREEN GR : GRAY L : BLUE LG : LIGHT GREEN O : ORANGE
P : PINK R : RED SB : SKY BLUE V : VIOLET W : WHITE Y : YELLOW

H1S12M03AB

TSB Revision

HEATER (CONTINUED)

3

AUTOMATIC COMPRESSOR CONTROLLER (C-15)

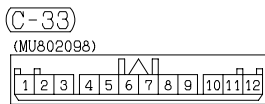
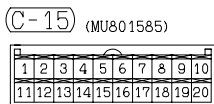
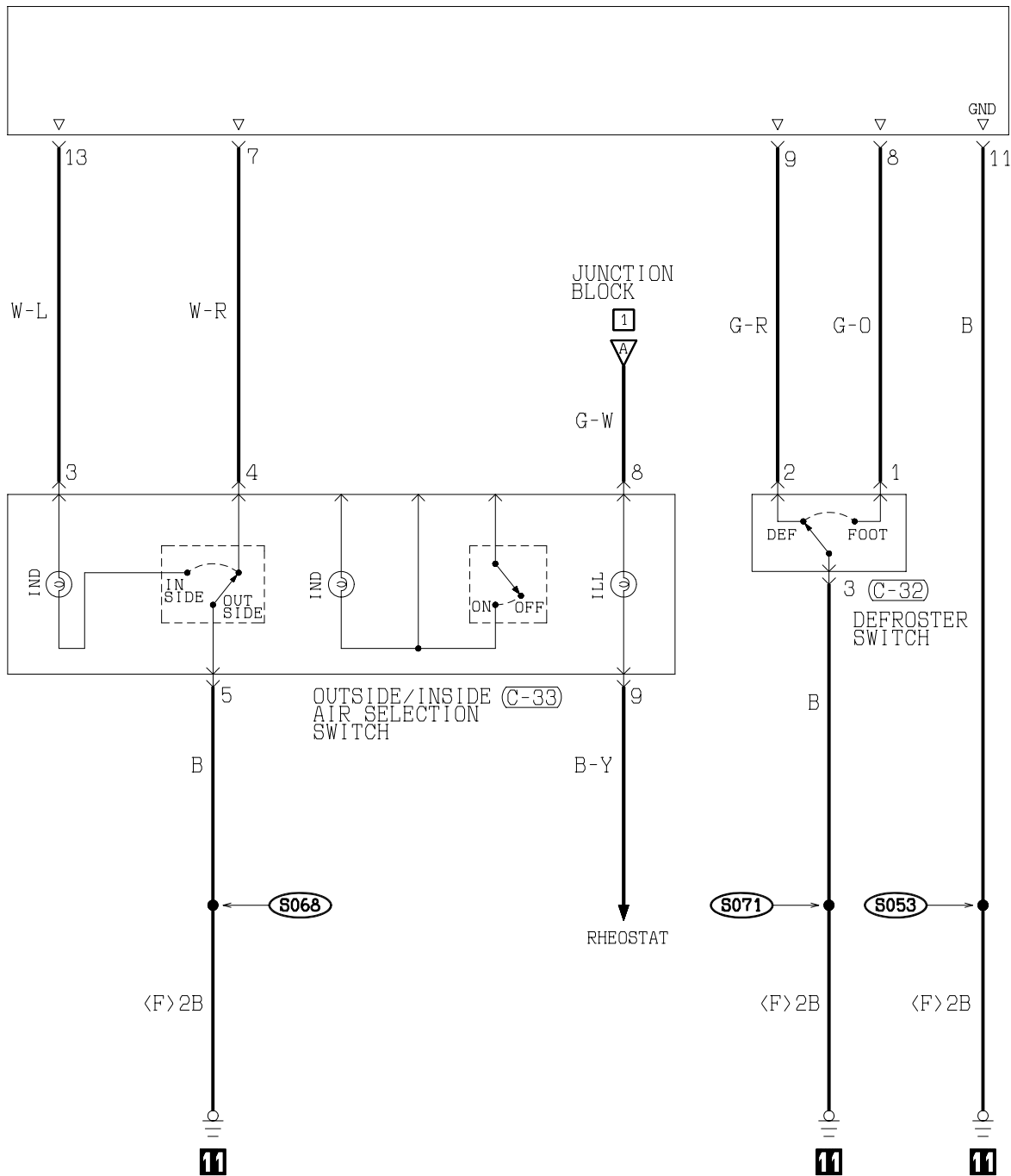

WIRE COLOR CODE
 B : BLACK BR : BROWN G : GREEN GR : GRAY L : BLUE LG : LIGHT GREEN O : ORANGE
 P : PINK R : RED SB : SKY BLUE V : VIOLET W : WHITE Y : YELLOW

H1S12M03BA

TSB Revision

NOTES

TSB Revision

AIR CONDITIONING SYSTEM <2.4L ENGINE>

M1901005500138

1

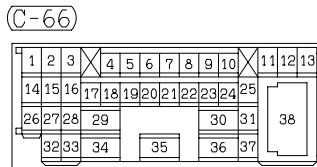
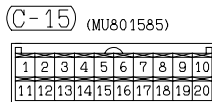
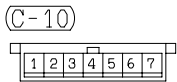
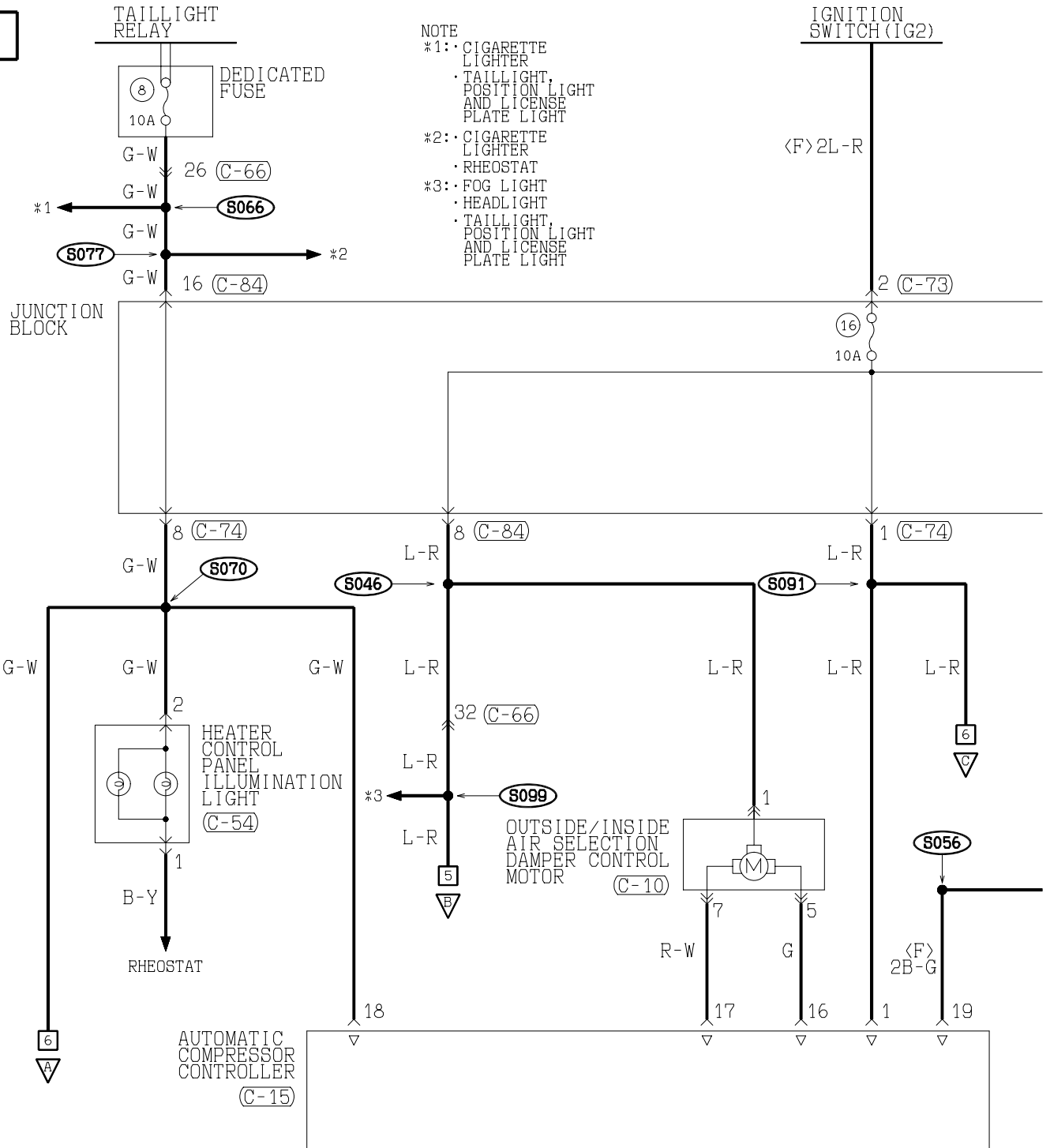

H1S12M04AA

TSB Revision

2

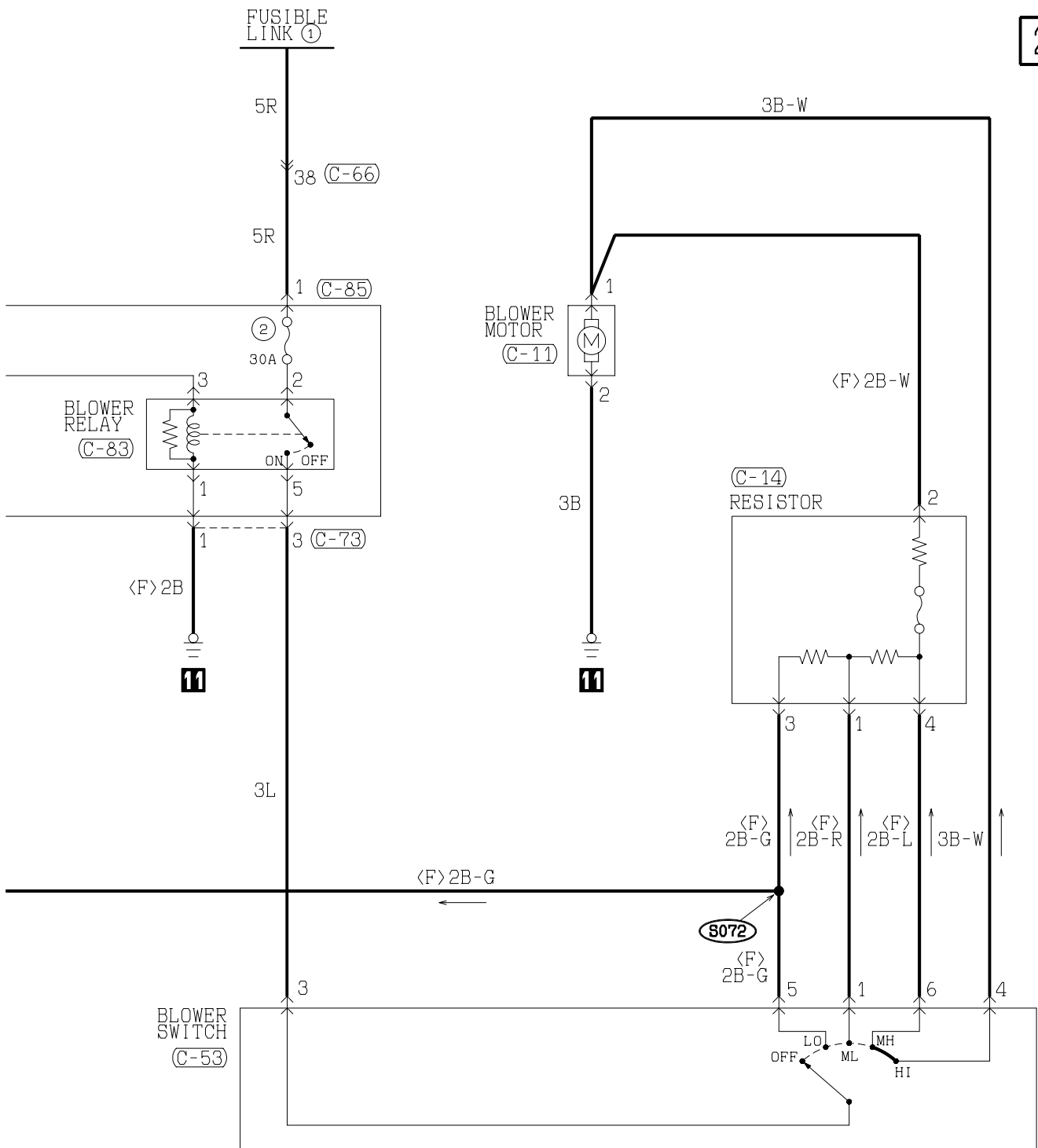

(C-74)

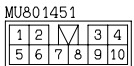

(C-83)



(C-84)

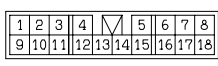

(C-85)



WIRE COLOR CODE

B : BLACK
P : PINK

BR : BROWN
R : RED

G : GREEN
SB : SKY BLUE

GR : GRAY
V : VIOLET

L : BLUE
W : WHITE

LG : LIGHT GREEN
Y : YELLOW

O : ORANGE

H1S12M04AB

TSB Revision

AIR CONDITIONING SYSTEM <2.4L ENGINE> (CONTINUED)

3

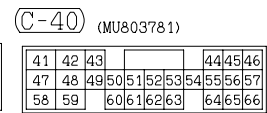
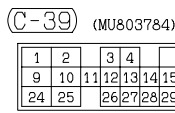
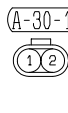
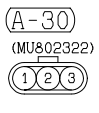
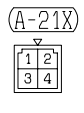
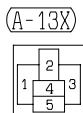
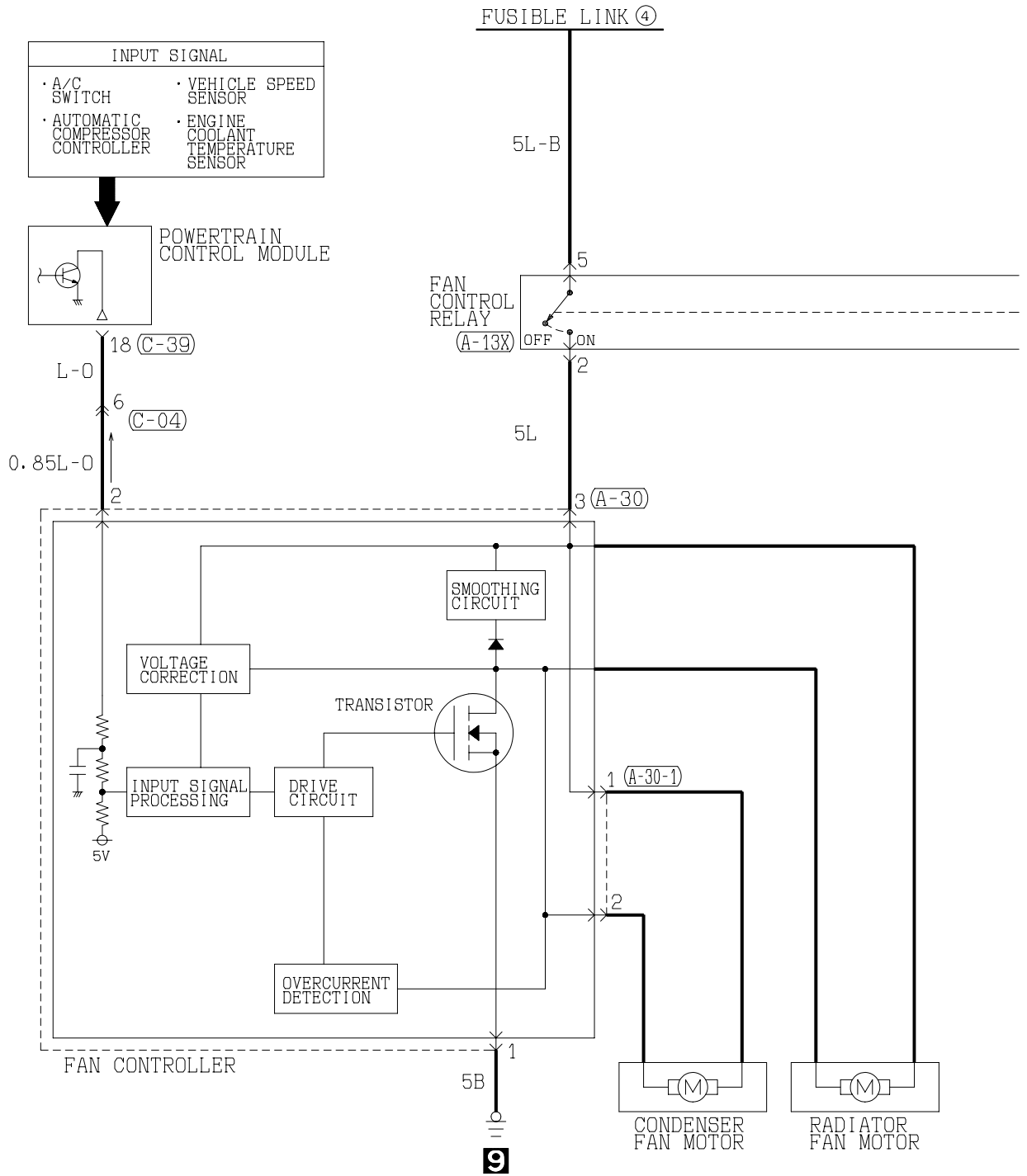

4

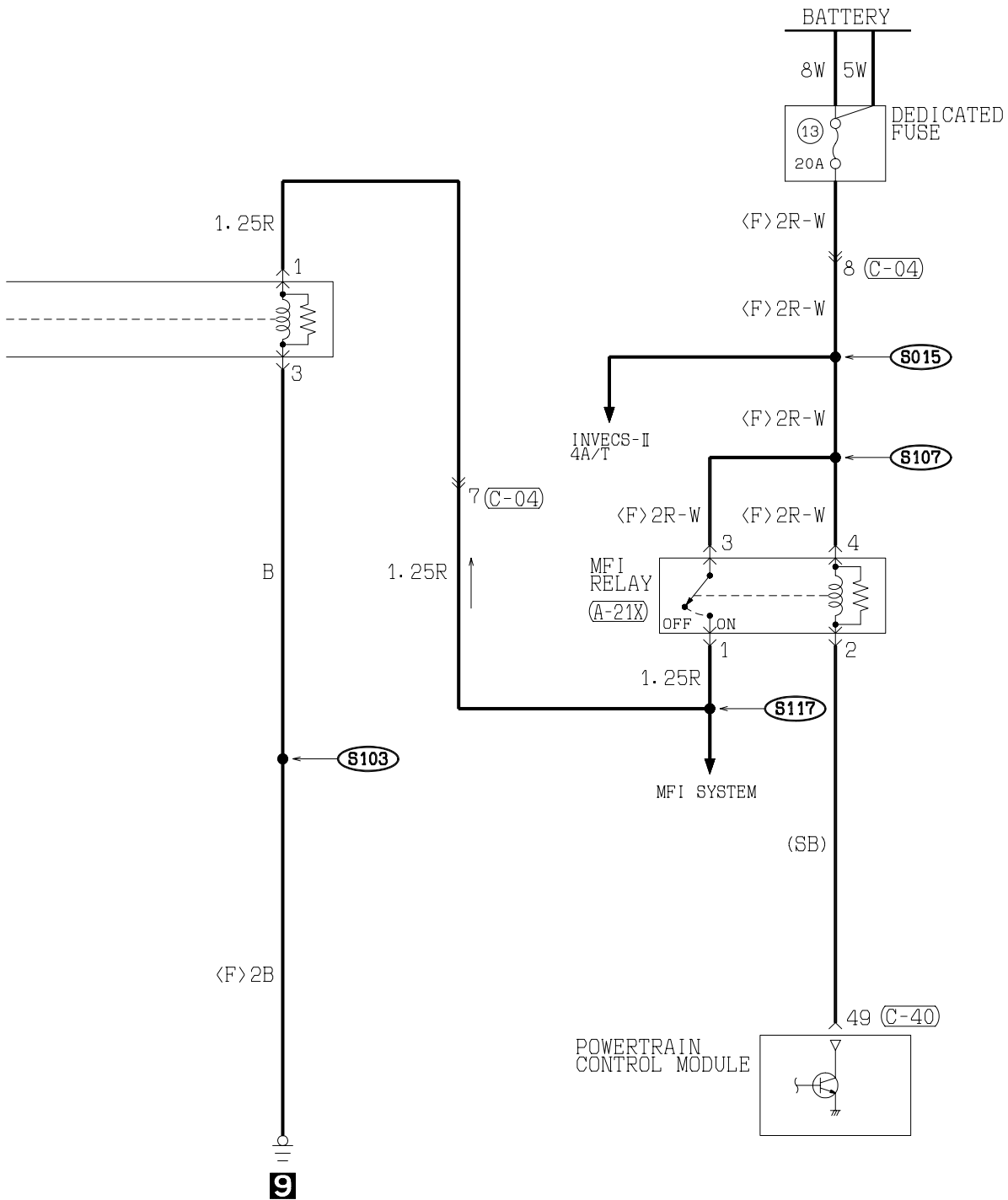

WIRE COLOR CODE
 B : BLACK BR : BROWN G : GREEN GR : GRAY L : BLUE LG : LIGHT GREEN O : ORANGE
 P : PINK R : RED SB : SKY BLUE V : VIOLET W : WHITE Y : YELLOW

H1S12M04BB

TSB Revision

AIR CONDITIONING SYSTEM <2.4L ENGINE> (CONTINUED)

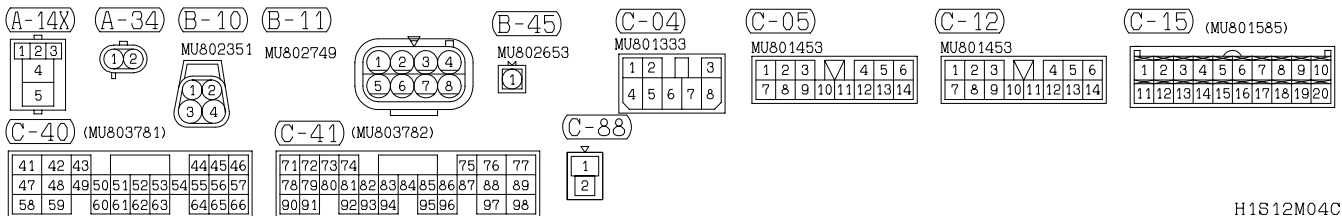
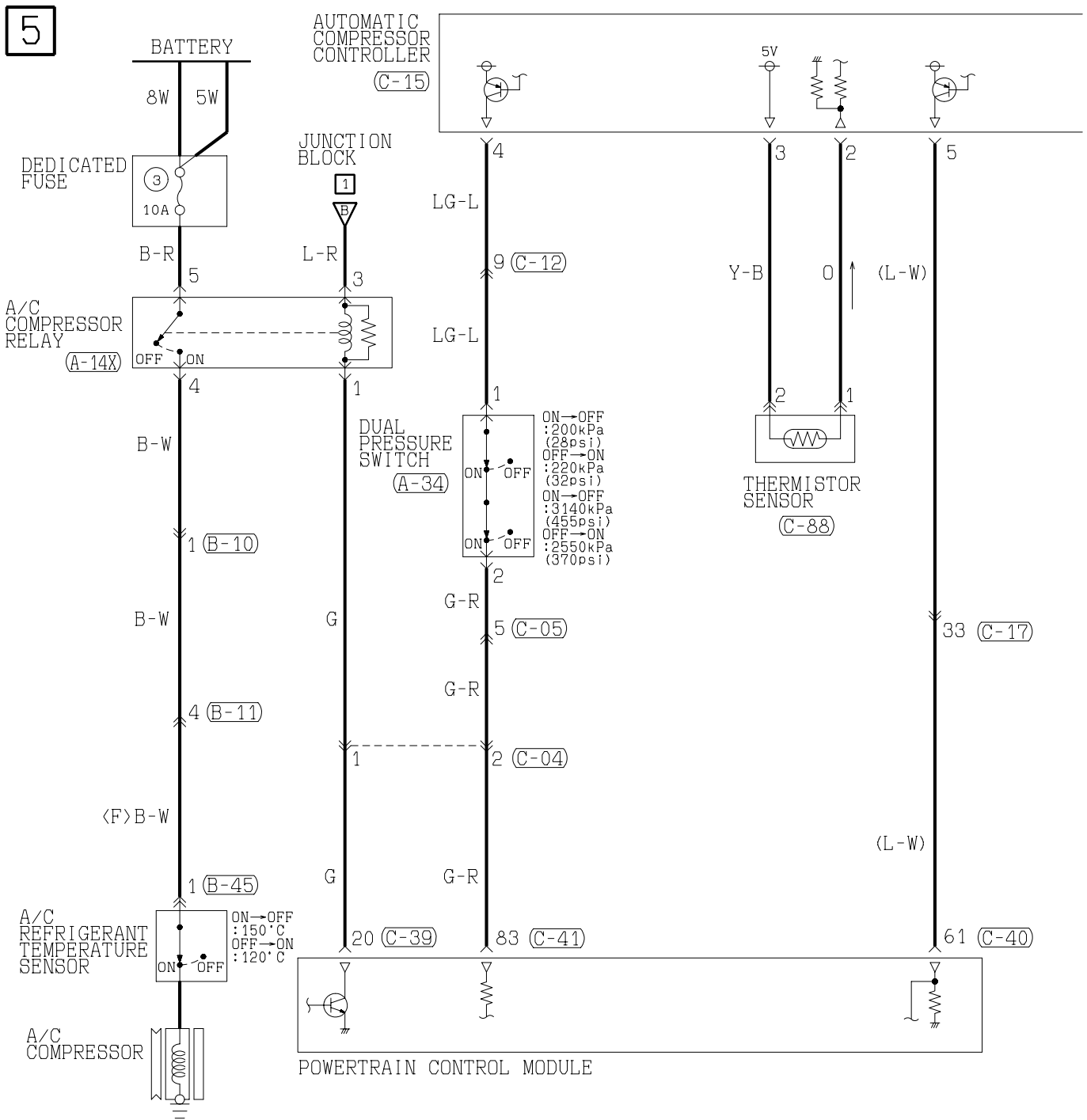

H1S12M04CA

6

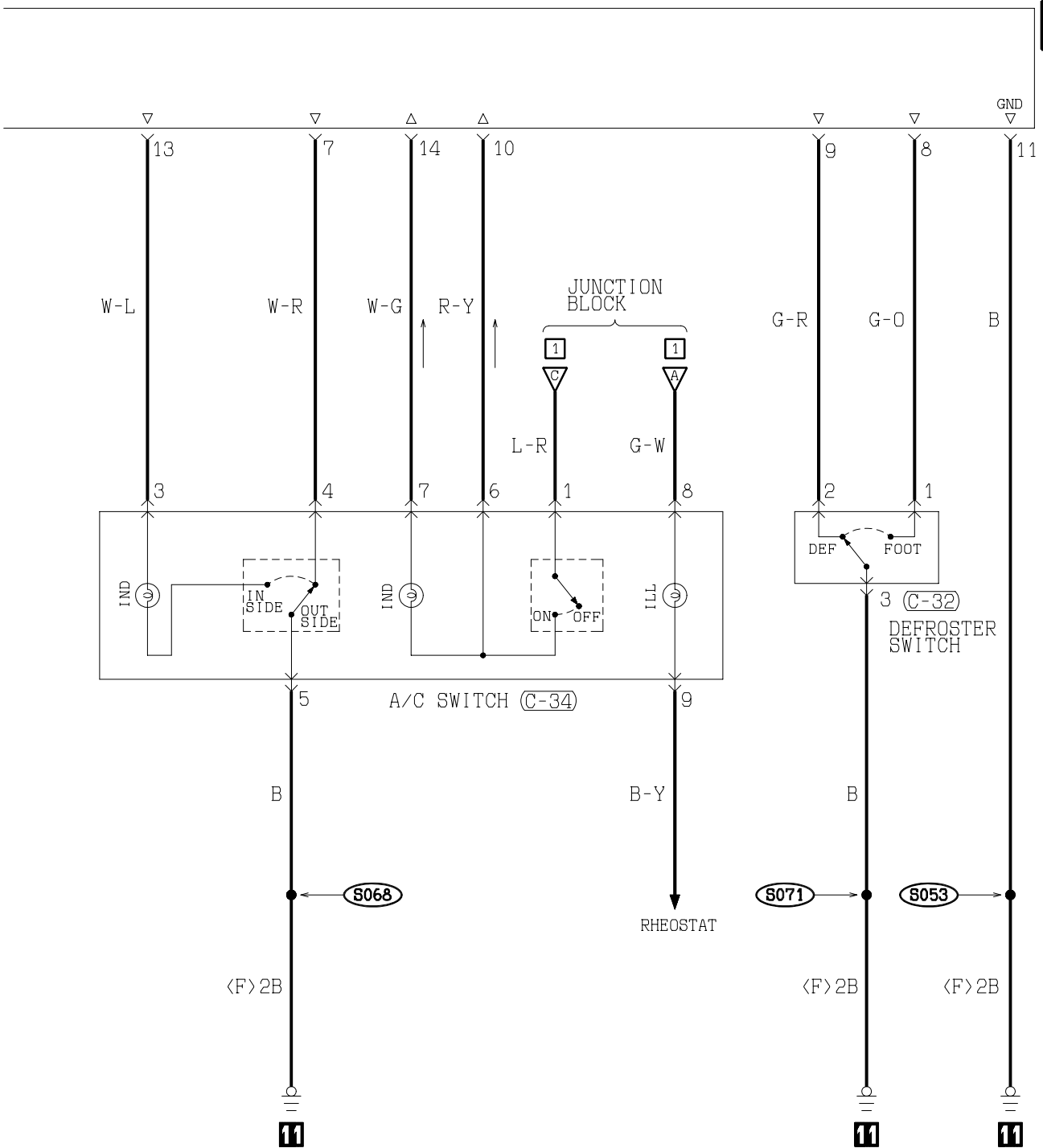

(C-17)

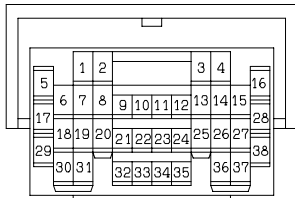

(C-32)



(C-34)

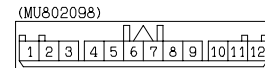

(C-39)

(MU803784)

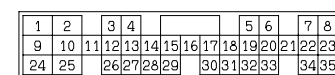

WIRE COLOR CODE

- B : BLACK
- L : BLUE
- R : RED
- Y : YELLOW
- BR : BROWN
- LG : LIGHT GREEN
- SB : SKY BLUE
- G : GREEN
- O : ORANGE
- V : VIOLET
- GR : GRAY
- P : PINK
- W : WHITE

H1S12M04CB

TSB Revision

AIR CONDITIONING SYSTEM <3.0L ENGINE>

M1901005500149

1

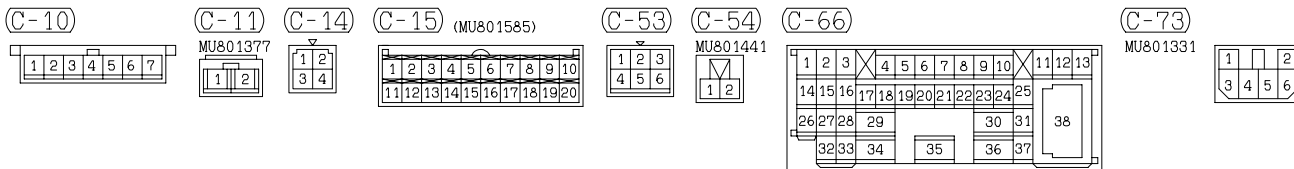
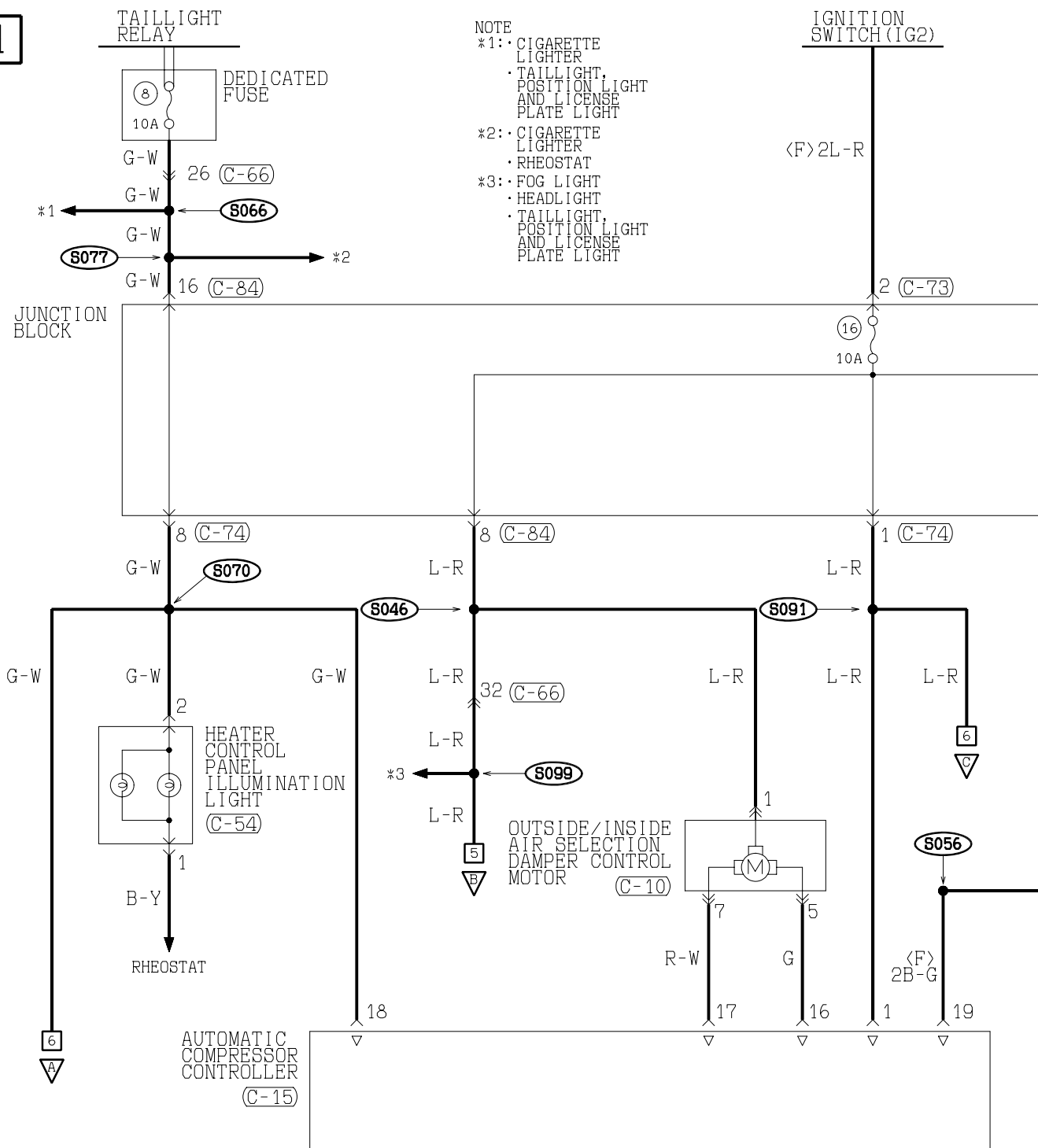

H1S12M05AA

TSB Revision

2

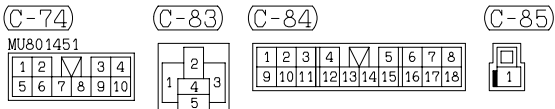
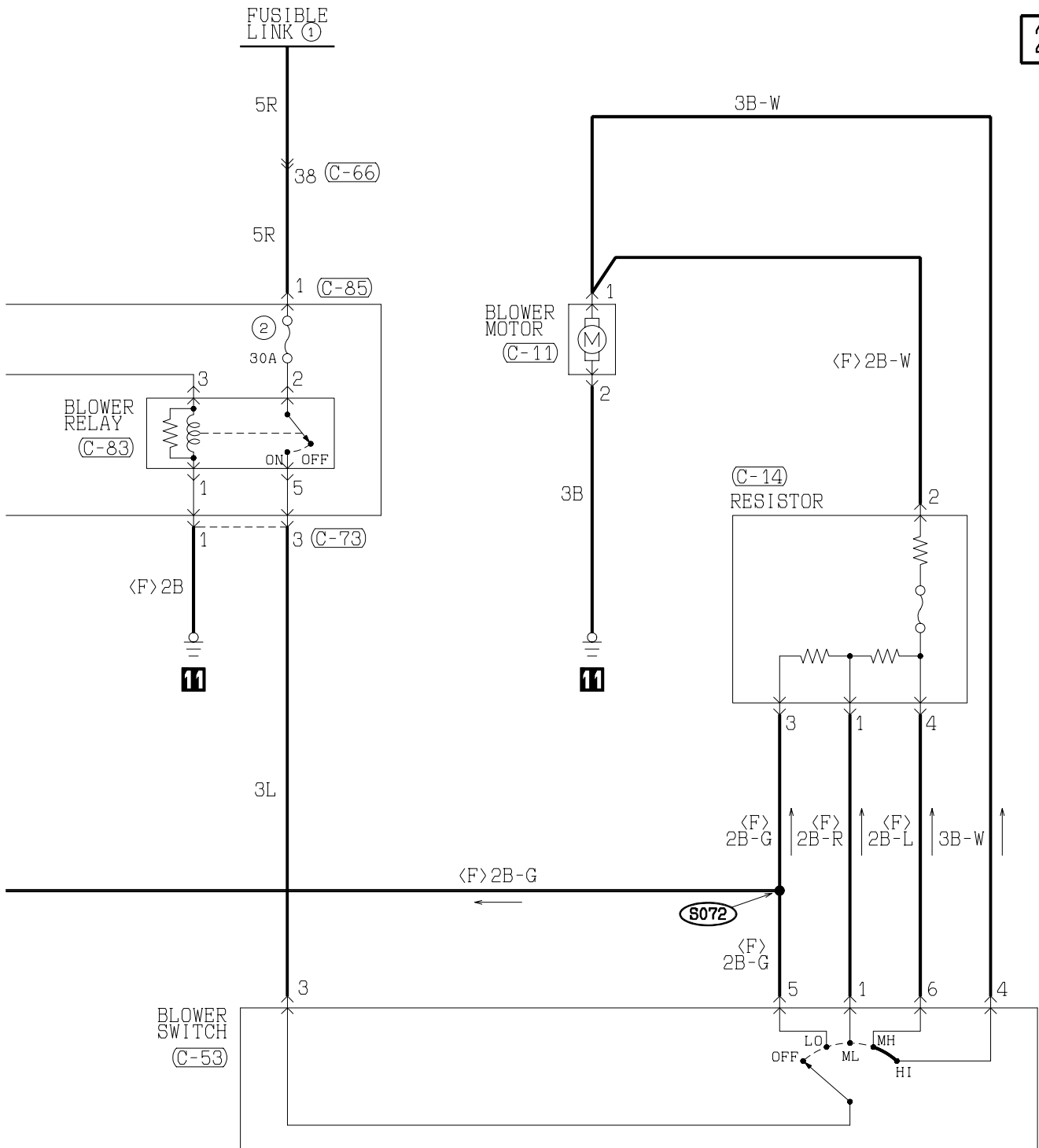

WIRE COLOR CODE
 B : BLACK BR : BROWN G : GREEN GR : GRAY L : BLUE LG : LIGHT GREEN O : ORANGE
 P : PINK R : RED SB : SKY BLUE V : VIOLET W : WHITE Y : YELLOW

H1S12M05AB

TSB Revision

AIR CONDITIONING SYSTEM <3.0L ENGINE> (CONTINUED)

3

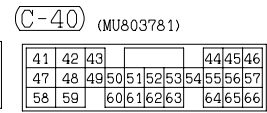
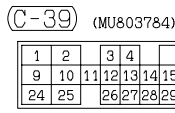
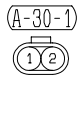
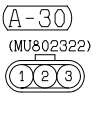
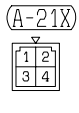
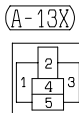
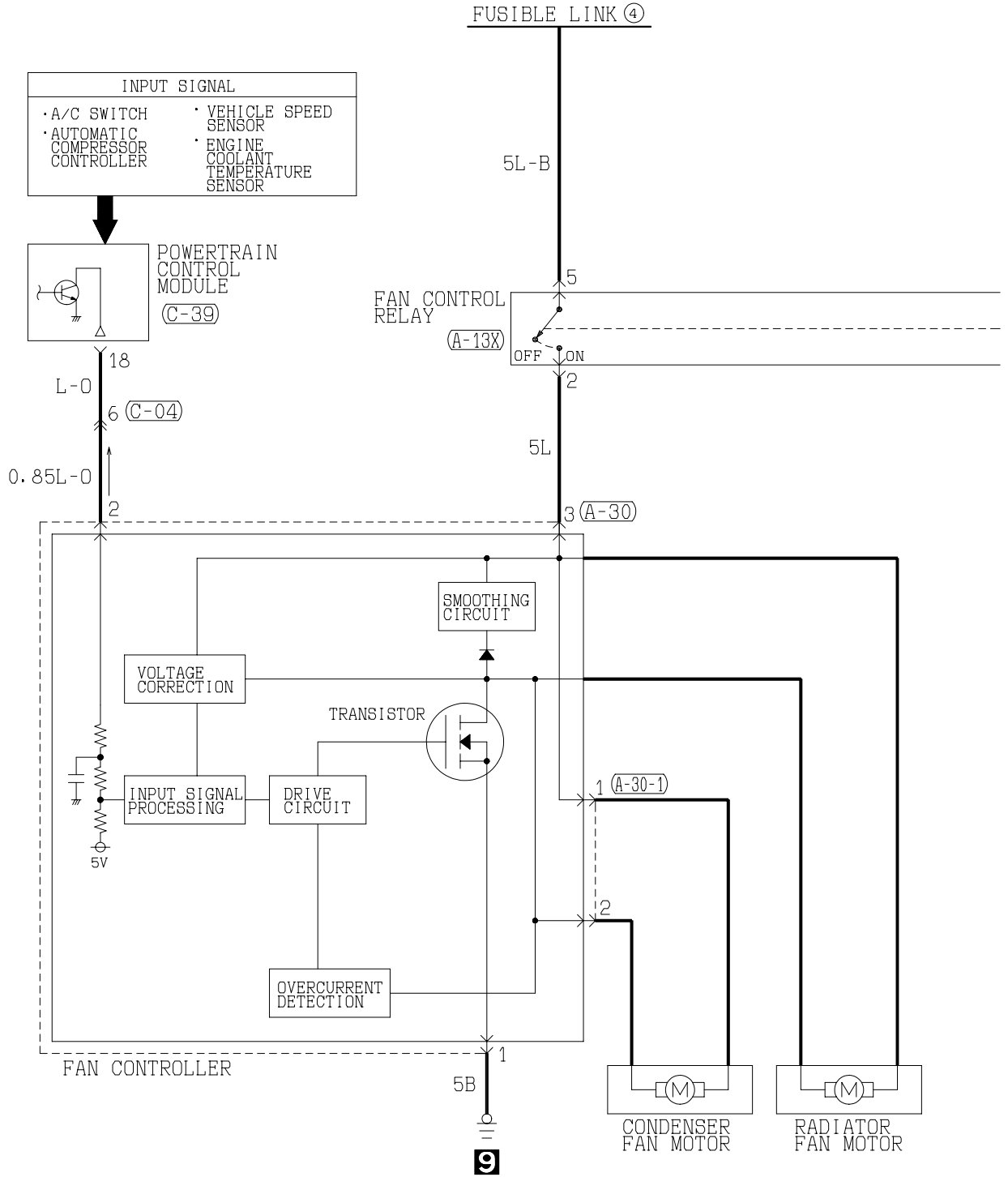

4

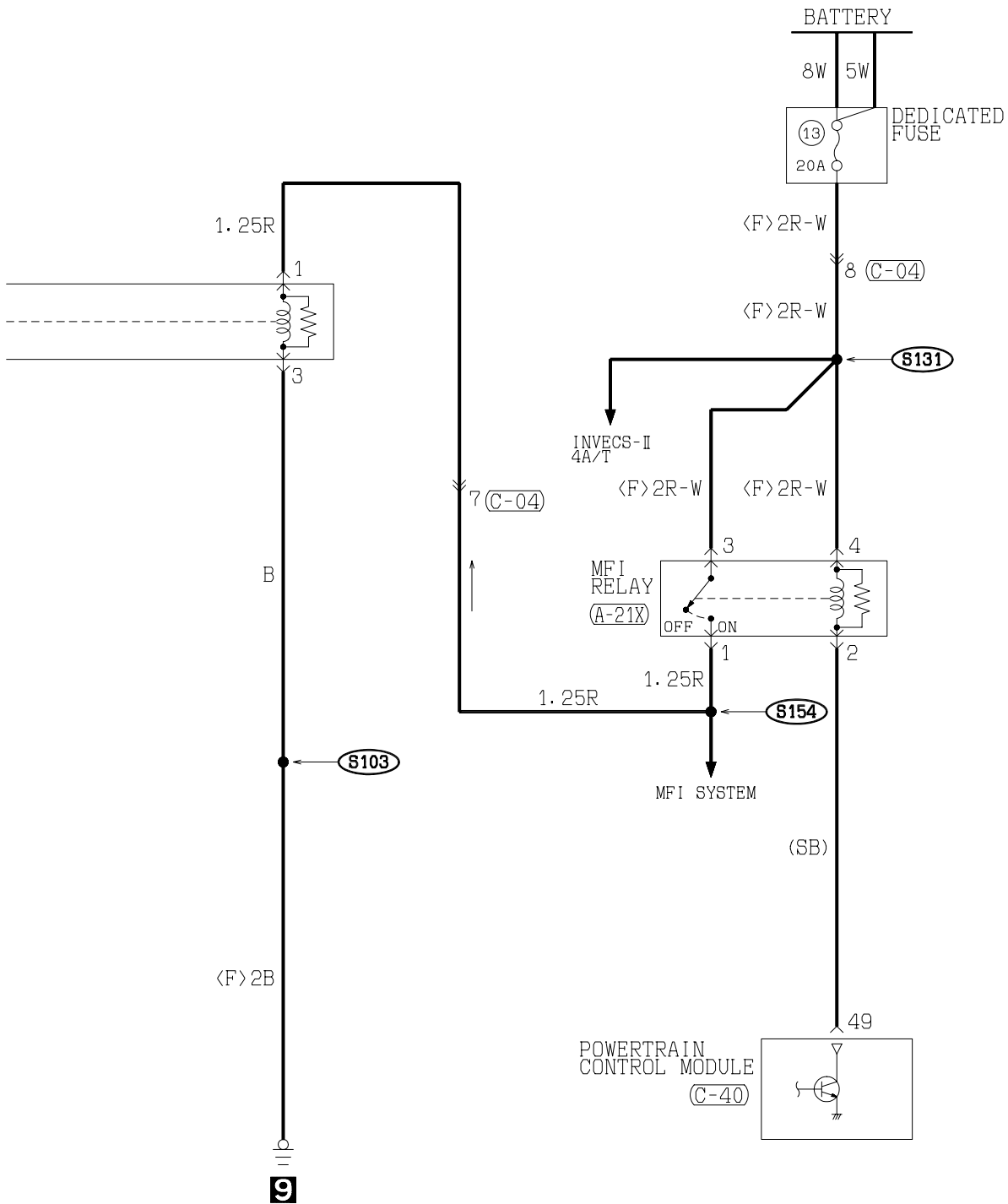

WIRE COLOR CODE
 B :BLACK BR:BROWN G :GREEN GR:GRAY L :BLUE LG:LIGHT GREEN O :ORANGE
 P :PINK R :RED SB:SKY BLUE V :VIOLET W :WHITE Y :YELLOW

H1S12M05BB

TSB Revision

AIR CONDITIONING SYSTEM <3.0L ENGINE> (CONTINUED)

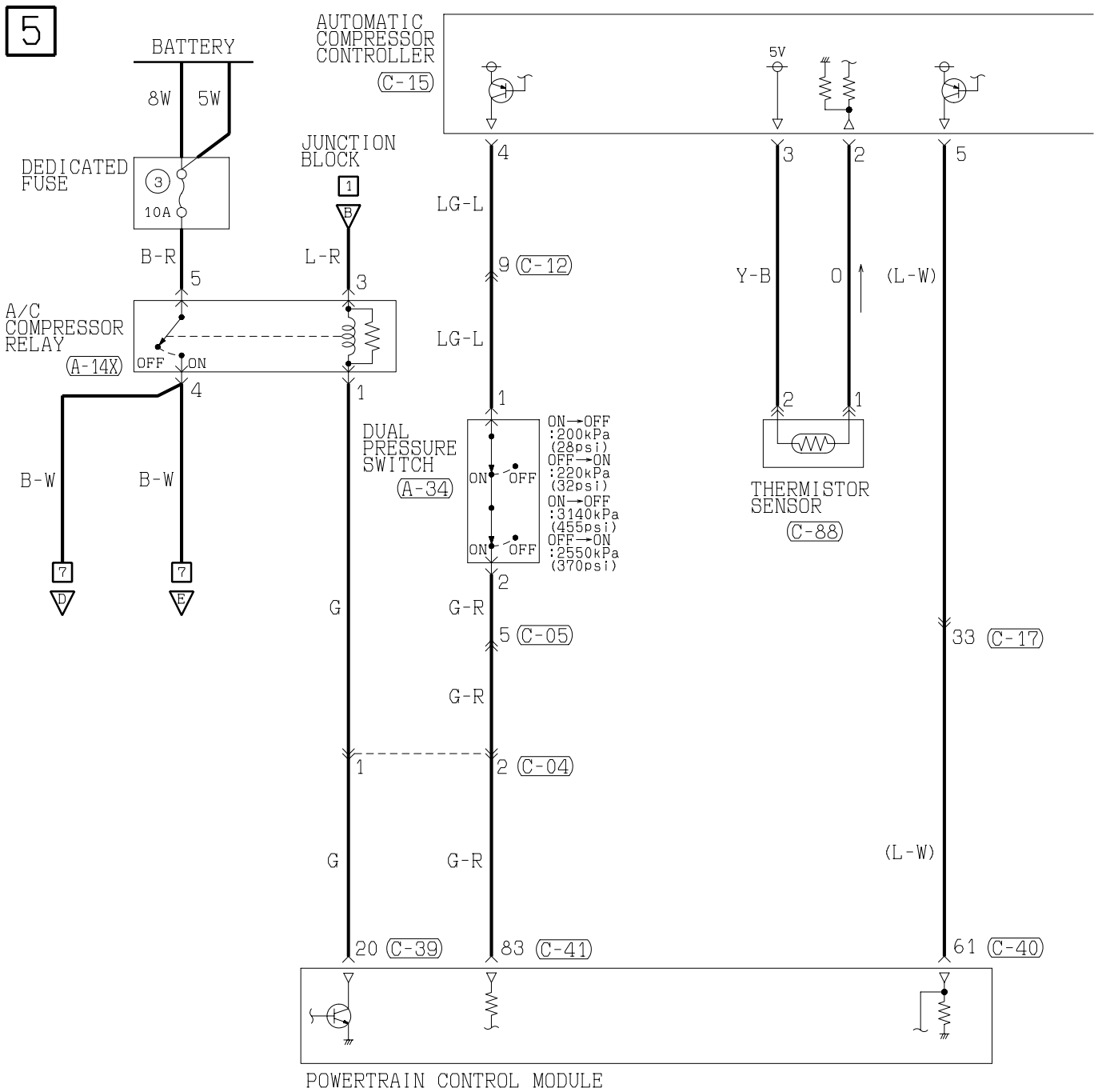

(A-14X)

(A-34)

(C-04)

(C-05)

(C-12)

(C-15) (MU801585)

1	2	3
4		
5		

MU801333

1	2		3
4	5	6	7
8			

1	2	3	4	5	6
7	8	9	10	11	12
13	14				

1	2	3	4	5	6
7	8	9	10	11	12
13	14				

1	2	3	4	5	6	7	8	9	10
11	12	13	14	15	16	17	18	19	20

(C-40) (MU803781)

41	42	43		44	45	46
47	48	49	50	51	52	53
54	55	56	57			
58	59	60	61	62	63	64
65	66					

(C-41) (MU803782)

71	72	73	74		75	76	77
78	79	80	81	82	83	84	85
86	87	88	89				
90	91	92	93	94	95	96	97
98							

(C-88)

1
2

6

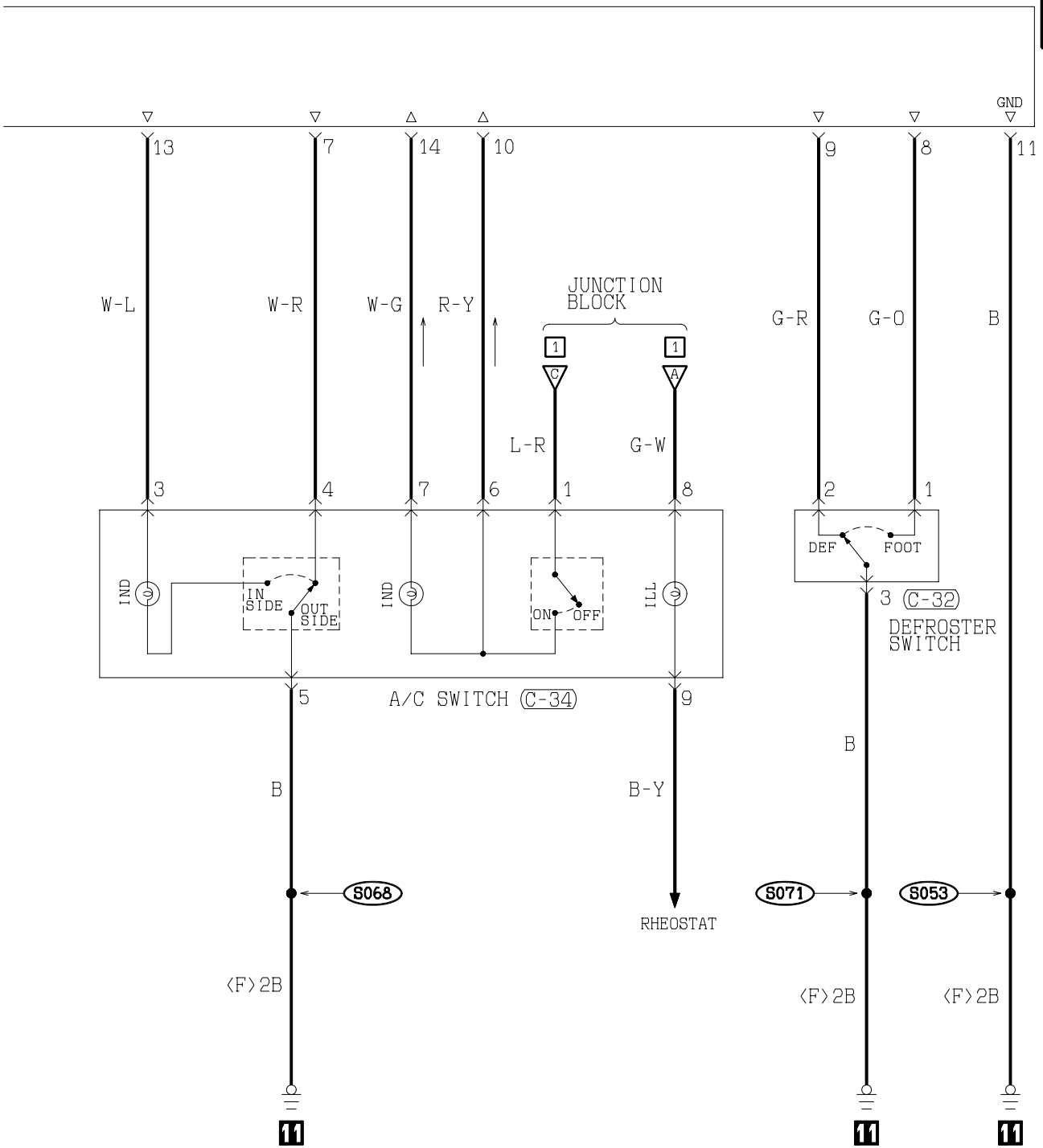

(C-17)

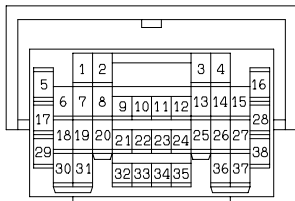

(C-32)



(C-34)



(C-39)

(MU803784)

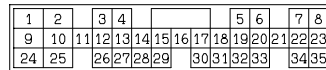

TSB Revision

AIR CONDITIONING SYSTEM <3.0L ENGINE> (CONTINUED)

7

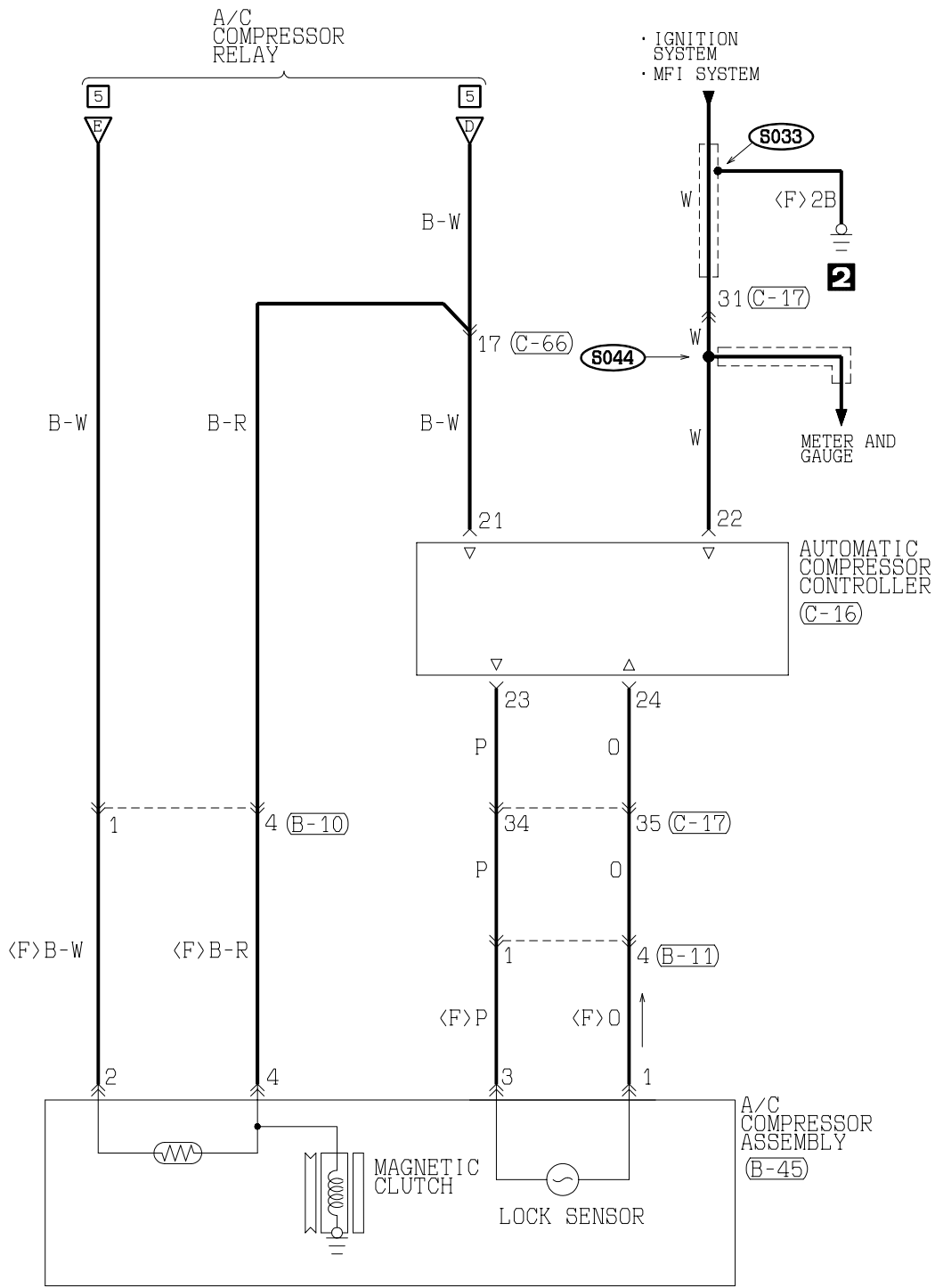

(B-10)
MU802351



(B-11)
MU802749

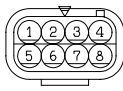

(B-45)
MU802605



(C-16)
(MU801582)



(C-17)

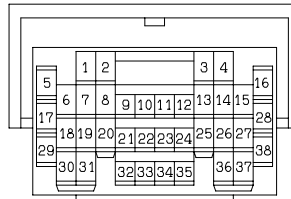

(C-66)

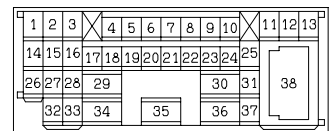

H1S12M05DA

TSB Revision

NOTES

TSB Revision

WINDSHIELD WIPER AND WASHER

M1901006100058

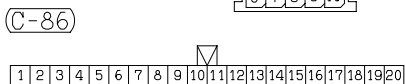
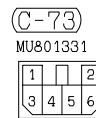
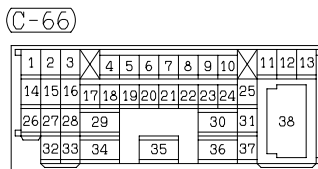
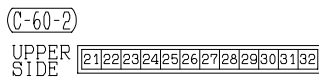
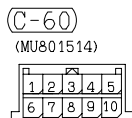
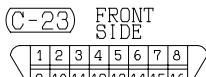
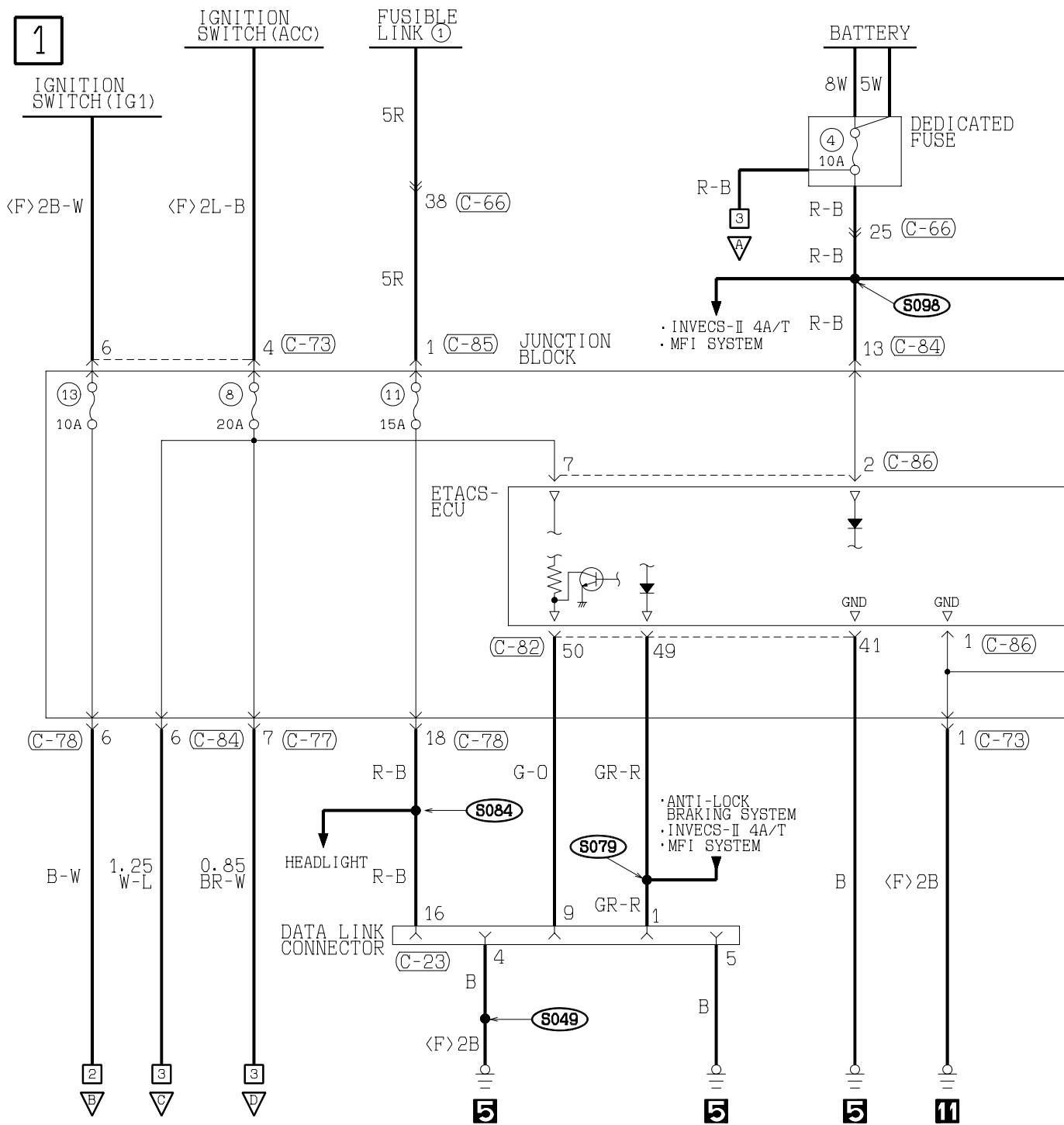

H1S13M03AA

TSB Revision

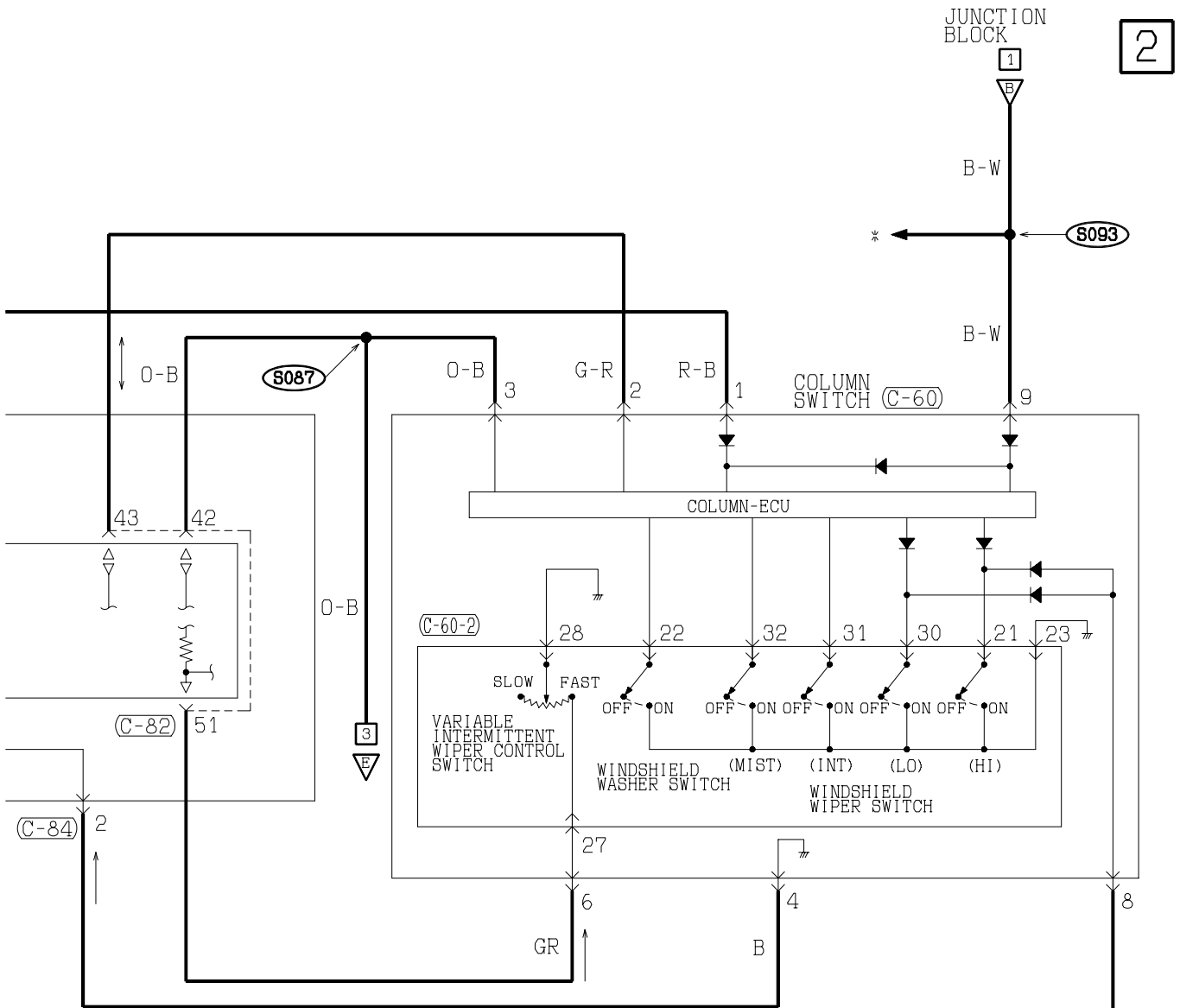

NOTE

- *: ANTI-LOCK BRAKING SYSTEM
- AUTO-CRUISE CONTROL SYSTEM
- BRAKE WARNING LIGHT
- CHARGING SYSTEM
- FUEL WARNING LIGHT
- METER AND GAUGE
- MFI SYSTEM
- OIL PRESSURE WARNING LIGHT
- SEAT BELT TONE ALARM
- SUPPLEMENTAL RESTRAINT SYSTEM

(C-77)

1	2	3	4	5	6	7	8	9	10
11	12	13	14	15	16	17	18	19	20
21	22								

(C-78)

MU801457

1	2	3	4	5	6	7	8	9
10	11	12	13	14	15	16	17	18
19	20							

(C-82) (MU801584)

41	42	43	44	45	46	47	48
49	50	51	52	53	54	55	56

(C-84)

1	2	3	4	5	6	7	8
9	10	11	12	13	14	15	16
17	18						

(C-85)

1

WIRE COLOR CODE
B : BLACK BR : BROWN
P : PINK R : RED

G : GREEN SB : SKY BLUE

GR : GRAY V : VIOLET

L : BLUE W : WHITE

LG : LIGHT GREEN Y : YELLOW

O : ORANGE

WINDSHIELD WIPER AND WASHER (CONTINUED)

3

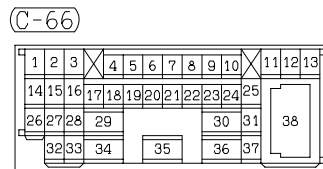
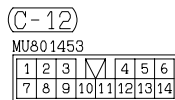
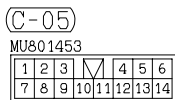
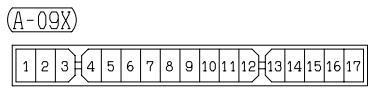
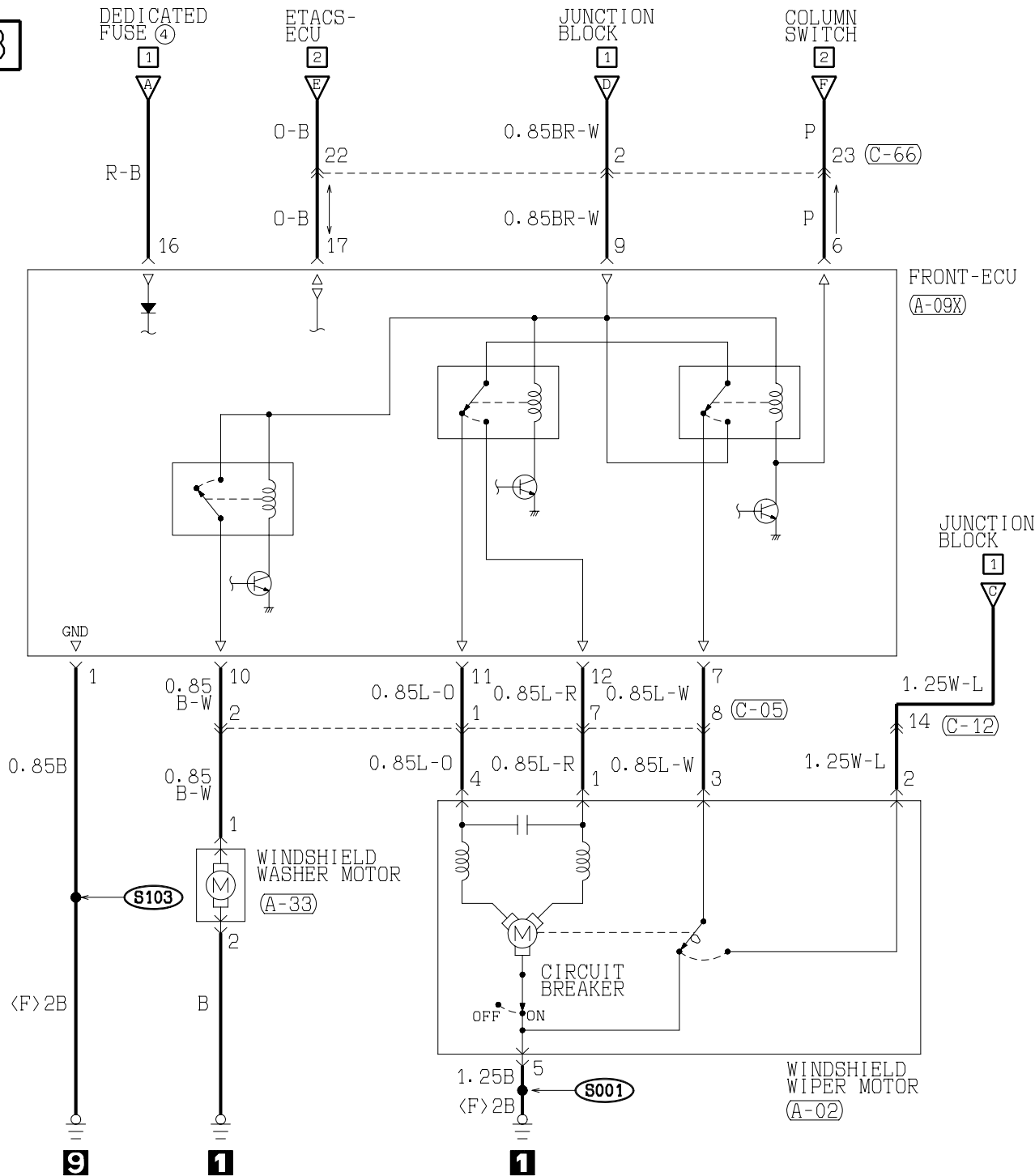

WIRE COLOR CODE

- B : BLACK BR: BROWN G : GREEN GR: GRAY
- L : BLUE LG: LIGHT GREEN O : ORANGE P : PINK
- R : RED SB: SKY BLUE V : VIOLET W : WHITE
- Y : YELLOW

H1S13M03BA

TSB Revision

NOTES

TSB Revision

DEFOGGER AND DOOR MIRROR HEATER

M1901013500070

1

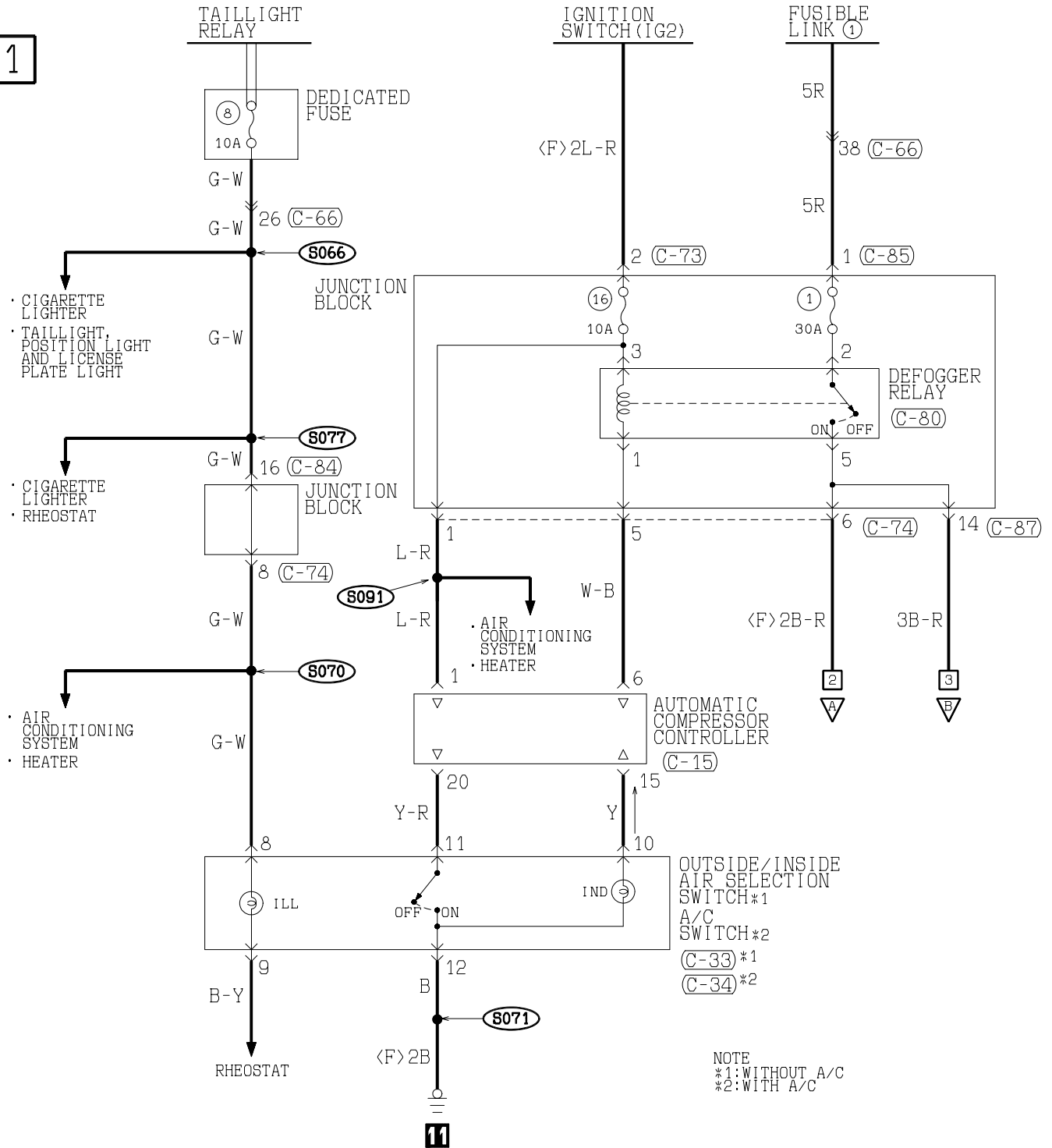

NOTE
*1: WITHOUT A/C
*2: WITH A/C

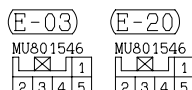
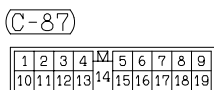
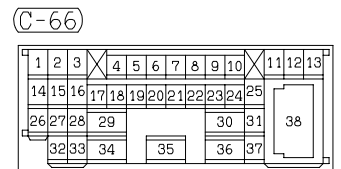
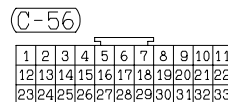
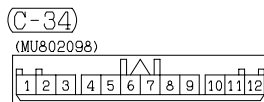
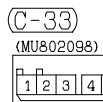
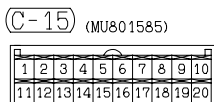

H1S13M04AA

TSB Revision

2

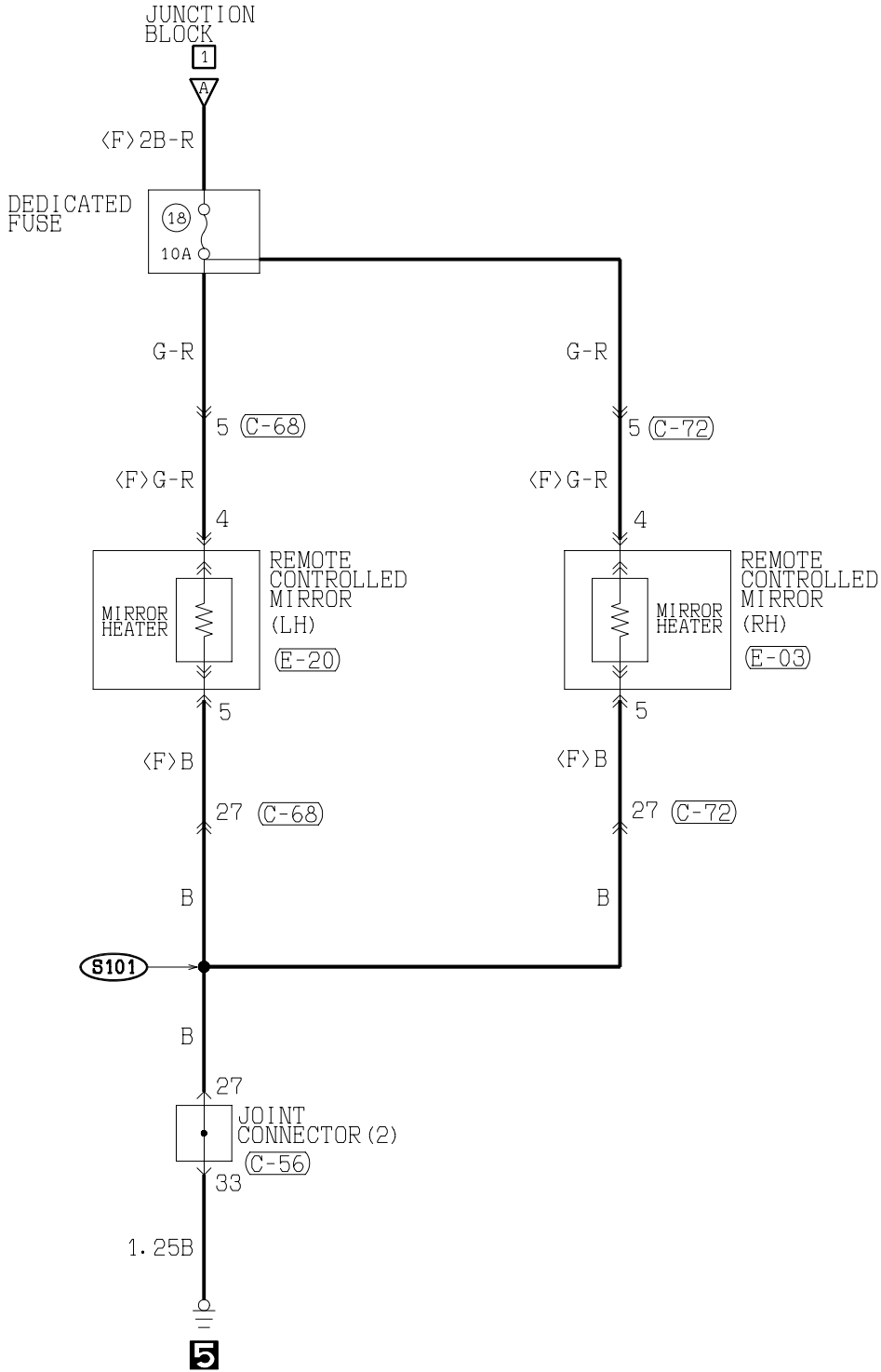

(C-68)

1	2	3	4	5	6	7	8	9
10	11	12	13	14	15	16	17	18
19	20	21	22	23	24	25	26	27
28	29	30	31	32				

(C-72)

1	2	3	4	5	6	7	8	9
10	11	12	13	14	15	16	17	18
19	20	21	22	23	24	25	26	27
28	29	30	31	32				

(C-73)

MU801331

1	2	
3	4	5
6		

(C-74)

MU801451

1	2	3	4
5	6	7	8
9	10		

(C-80)

2	
1	3
4	5

(C-84)

1	2	3	4	5	6	7	8
9	10	11	12	13	14	15	16
17	18						

(C-85)

1

WIRE COLOR CODE

B : BLACK BR : BROWN G : GREEN GR : GRAY L : BLUE LG : LIGHT GREEN O : ORANGE
P : PINK R : RED SB : SKY BLUE V : VIOLET W : WHITE Y : YELLOW

H1S13M04AB

TSB Revision

DEFOGGER AND DOOR MIRROR HEATER (CONTINUED)

3

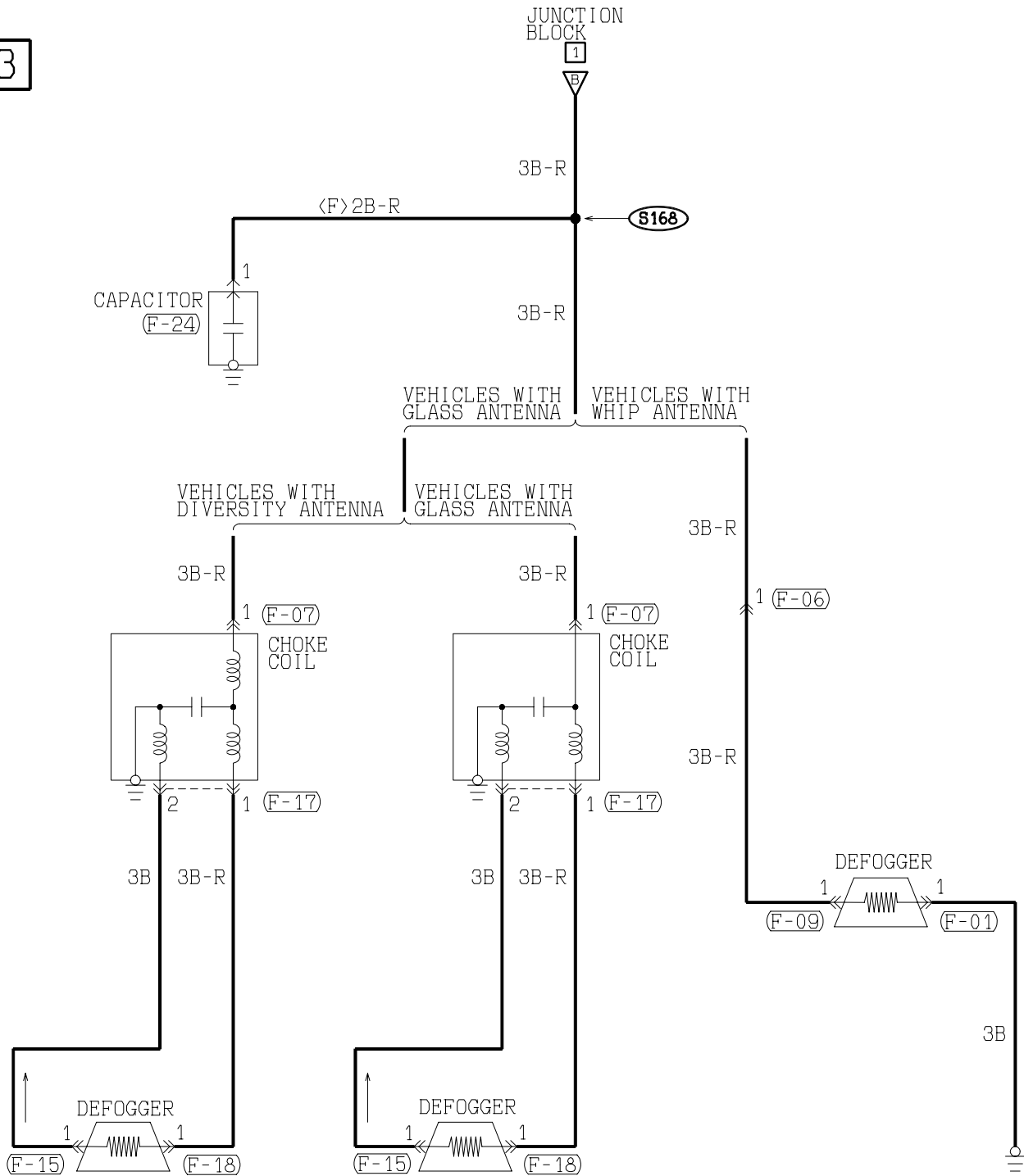

- (F-01)
- (F-06)
- (F-07)
- (F-09)
- (F-15)
- (F-17)
- (F-18)
- (F-24) (MU801211)

WIRE COLOR CODE
 B :BLACK BR: BROWN G :GREEN GR:GRAY L :BLUE LG:LIGHT GREEN O :ORANGE
 P :PINK R :RED SB:SKY BLUE V :VIOLET W :WHITE Y :YELLOW

H1S13M04BA

TSB Revision

M1901006500056

REMOTE CONTROLLED MIRROR

1

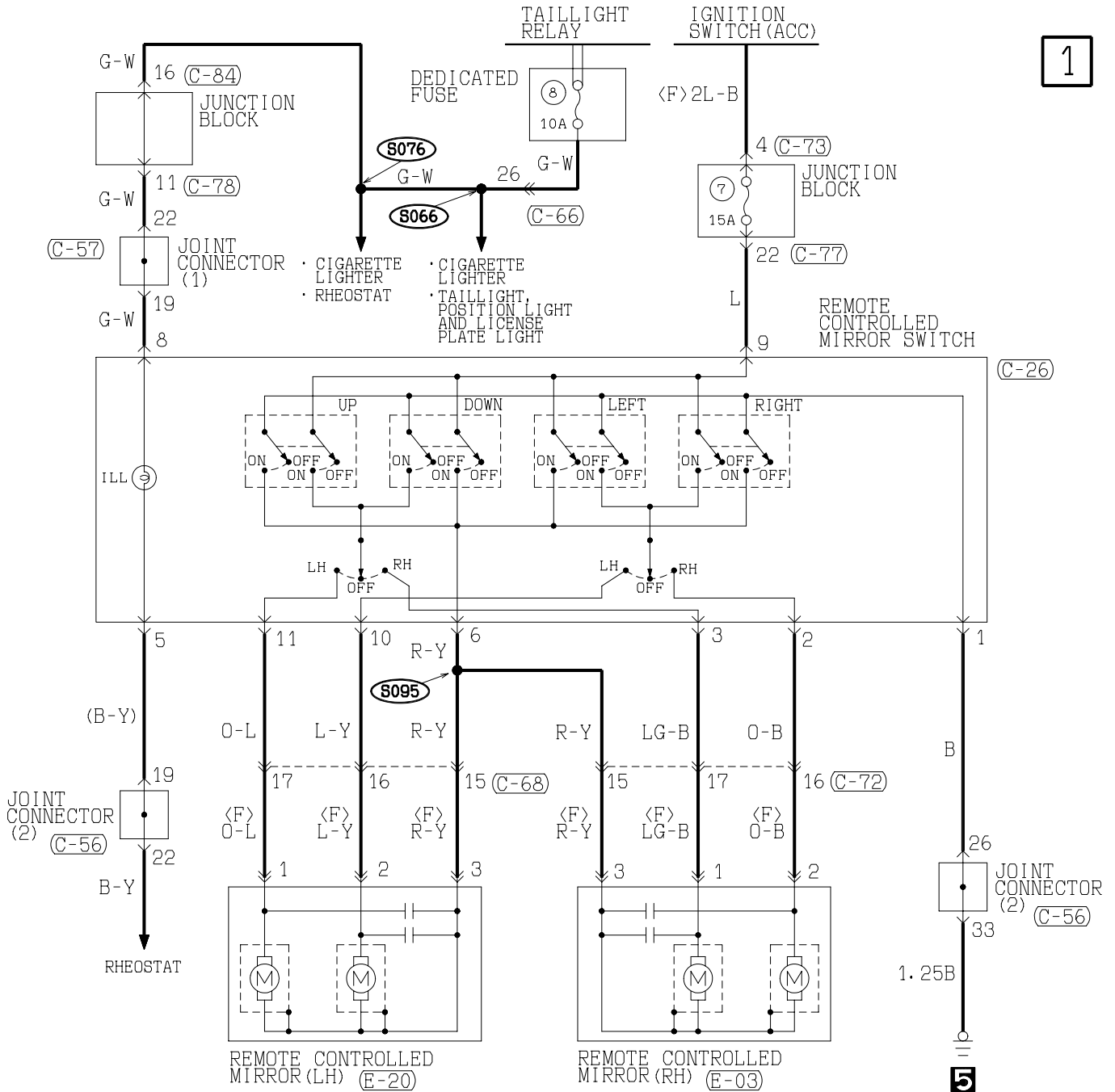

(C-26)

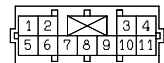

(C-56)



(C-57)



(C-66)

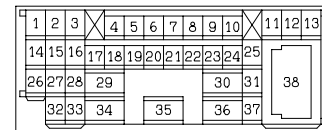

(C-68)

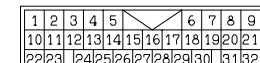

(C-72)

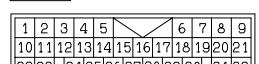

(C-73)

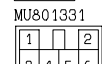

(C-77)

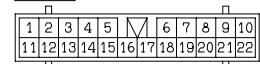

(C-78)

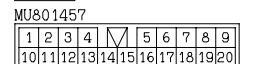

(C-84)

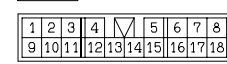

(E-03)

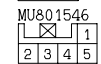

(E-20)

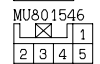

H1S13M05AA

RADIO AND TAPE PLAYER <4-SPEAKER SYSTEM>

M1901007200047

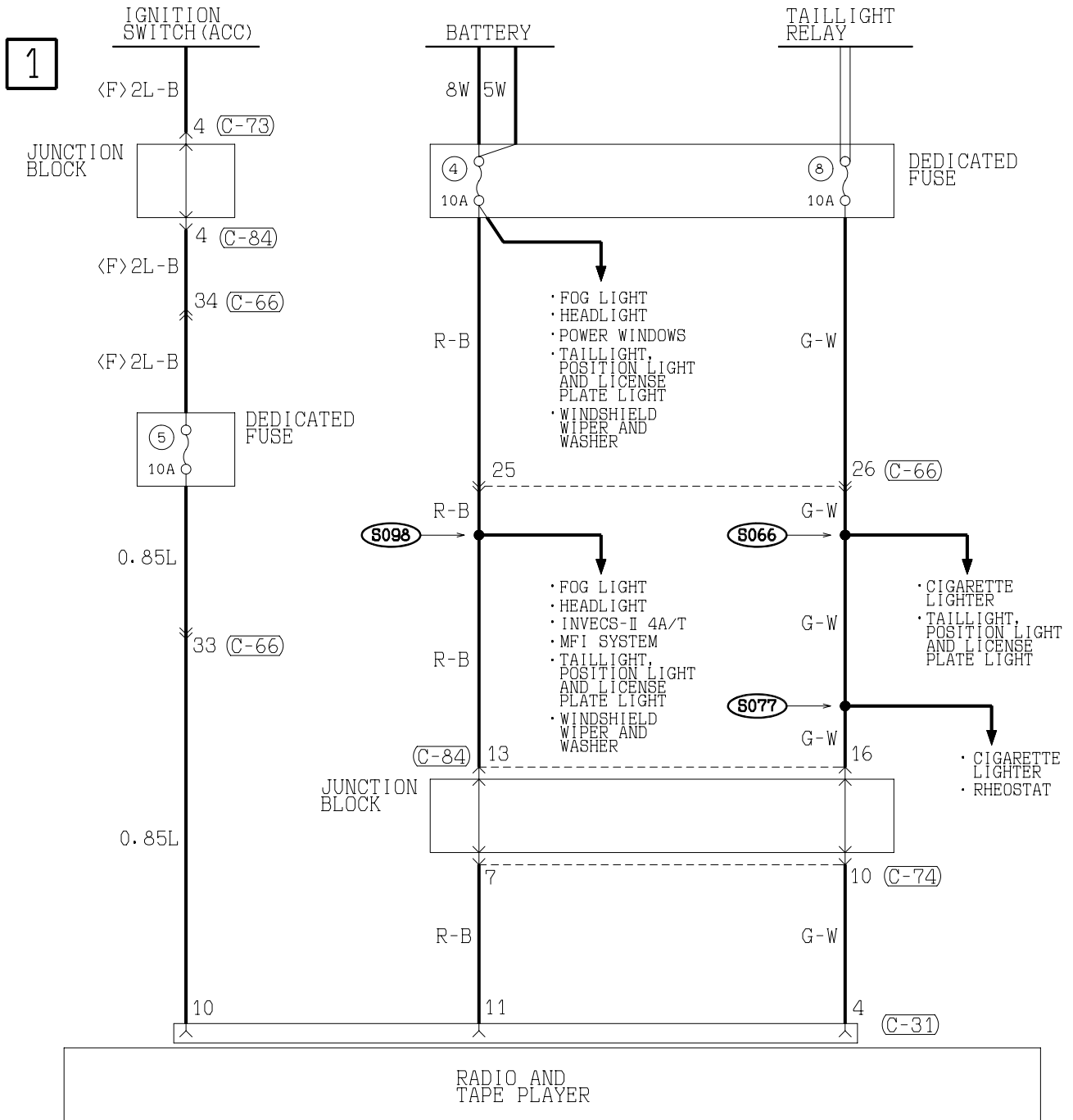

NOTE
 *1: 2.4L ENGINE
 *2: 3.0L ENGINE

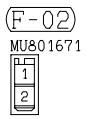
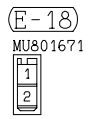
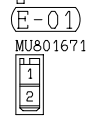
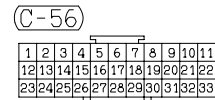
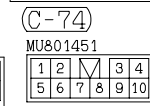
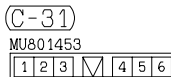
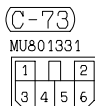
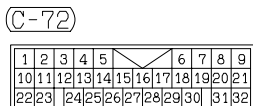
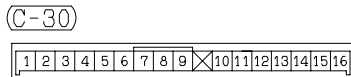
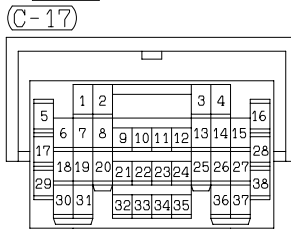
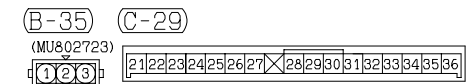

H1S14M05AA

TSB Revision

2

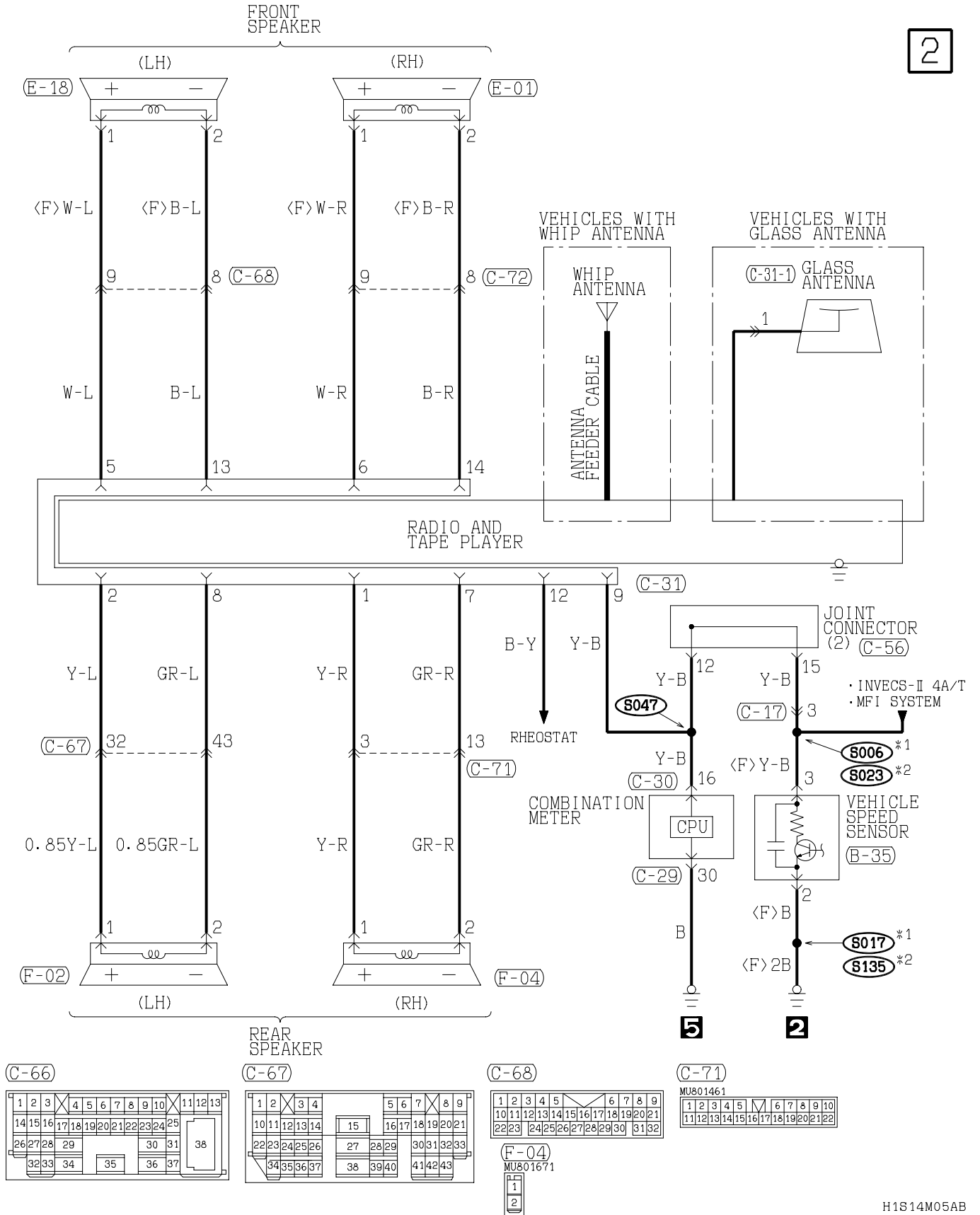

TSB Revision

RADIO AND TAPE PLAYER <7-SPEAKER SYSTEM>

M1901007200058

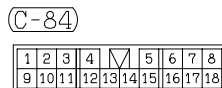
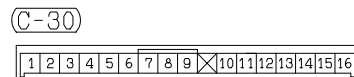
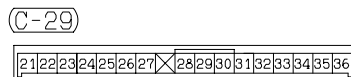
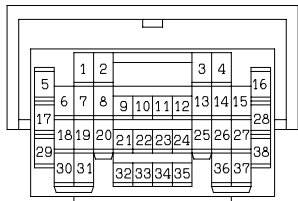
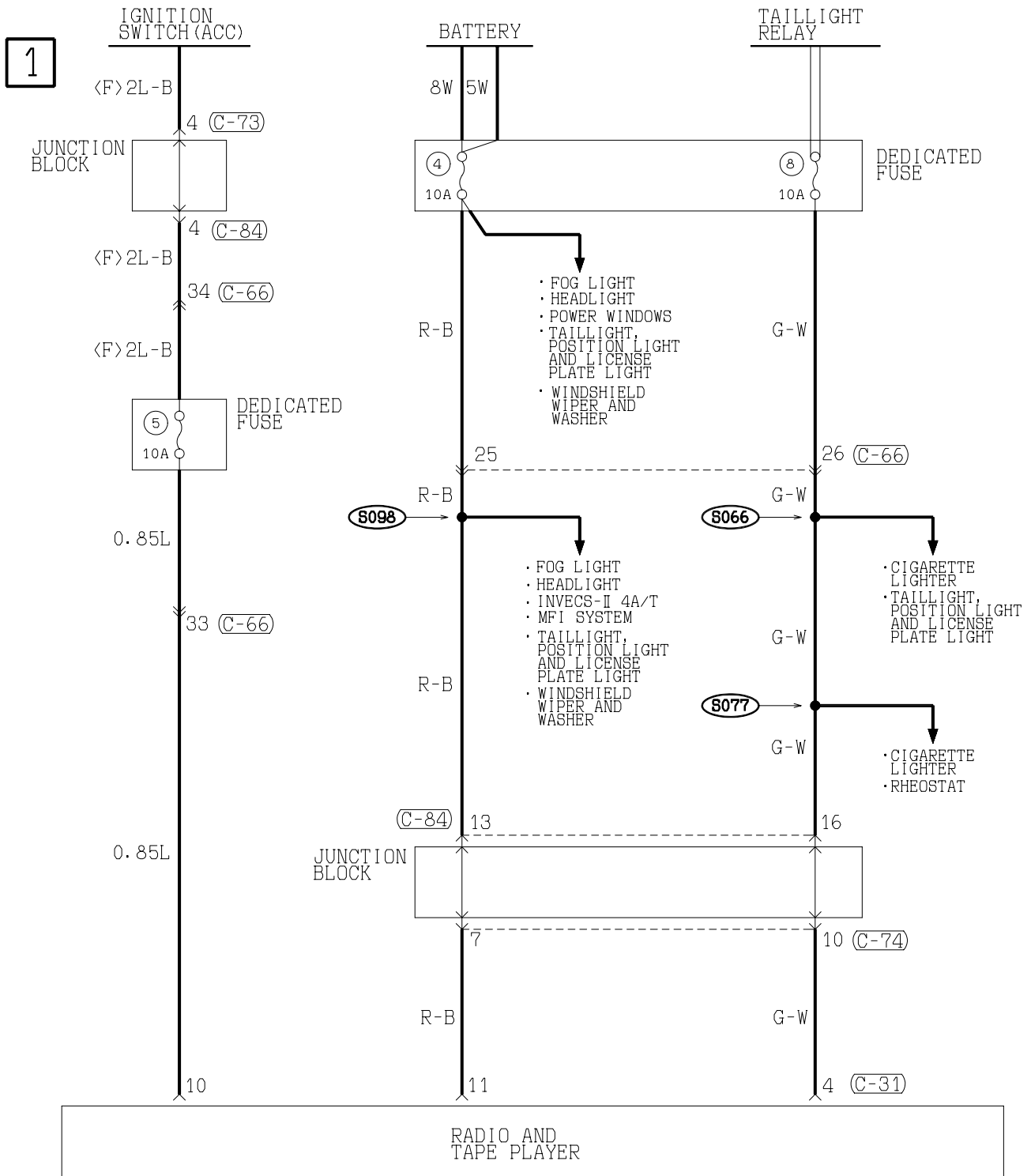

H1S14M06AA

2

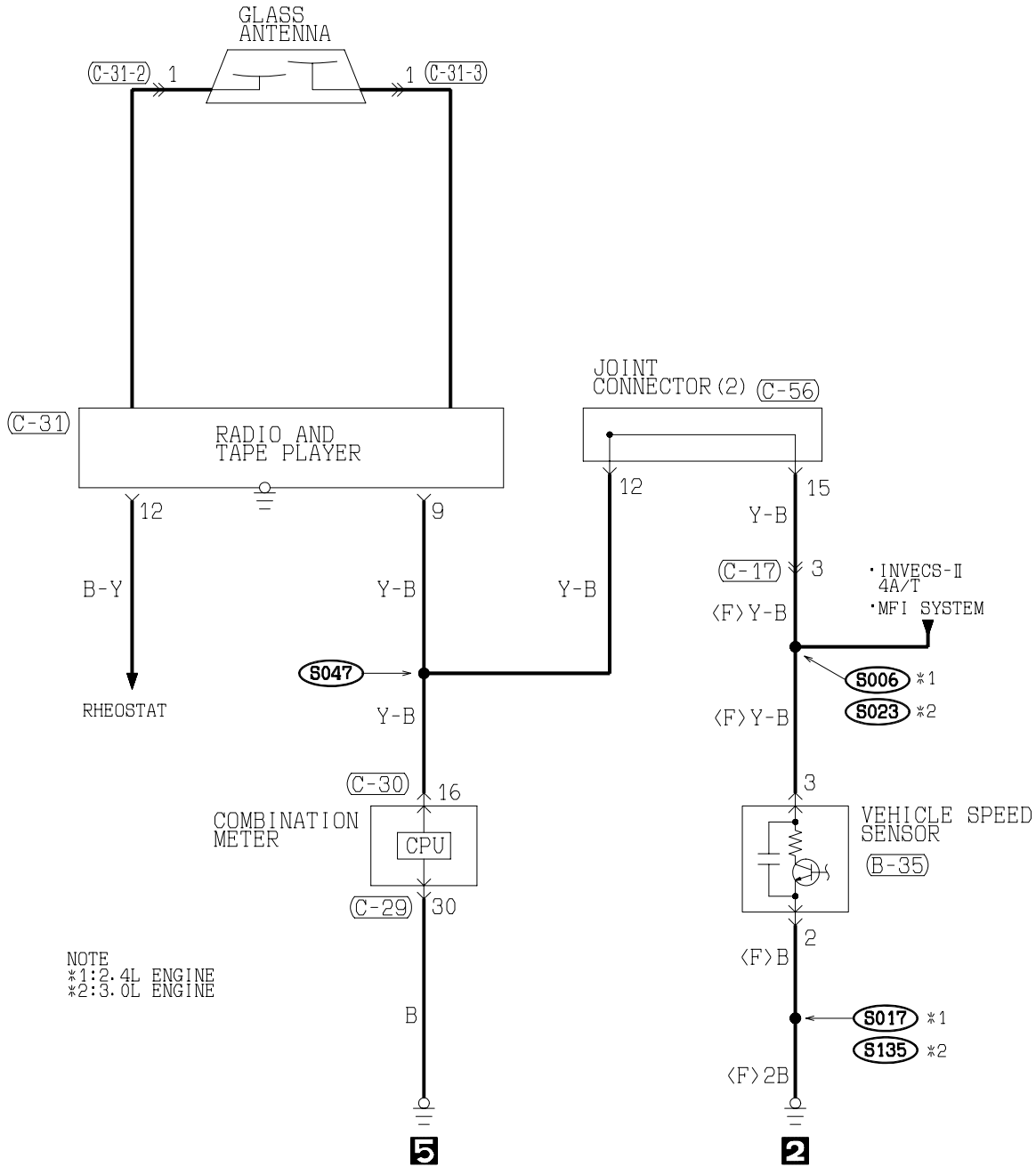

NOTE
 *1:2.4L ENGINE
 *2:3.0L ENGINE

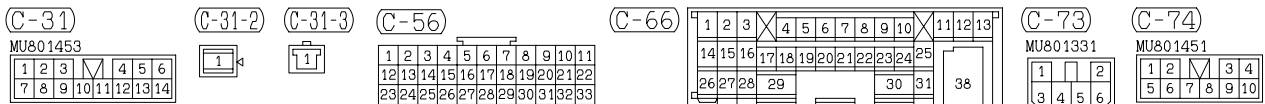

WIRE COLOR CODE
 B : BLACK LG : LIGHT GREEN G : GREEN L : BLUE
 BR : BROWN O : ORANGE GR : GRAY R : RED
 W : WHITE SB : SKY BLUE P : PINK Y : YELLOW
 V : VIOLET

H1S14M06AB

TSB Revision

RADIO AND TAPE PLAYER <7-SPEAKER SYSTEM> (CONTINUED)

3

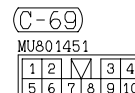
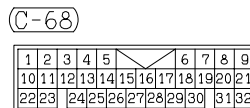
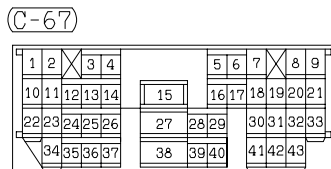
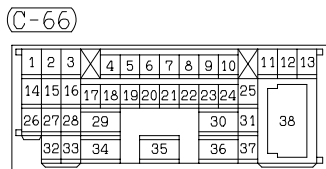
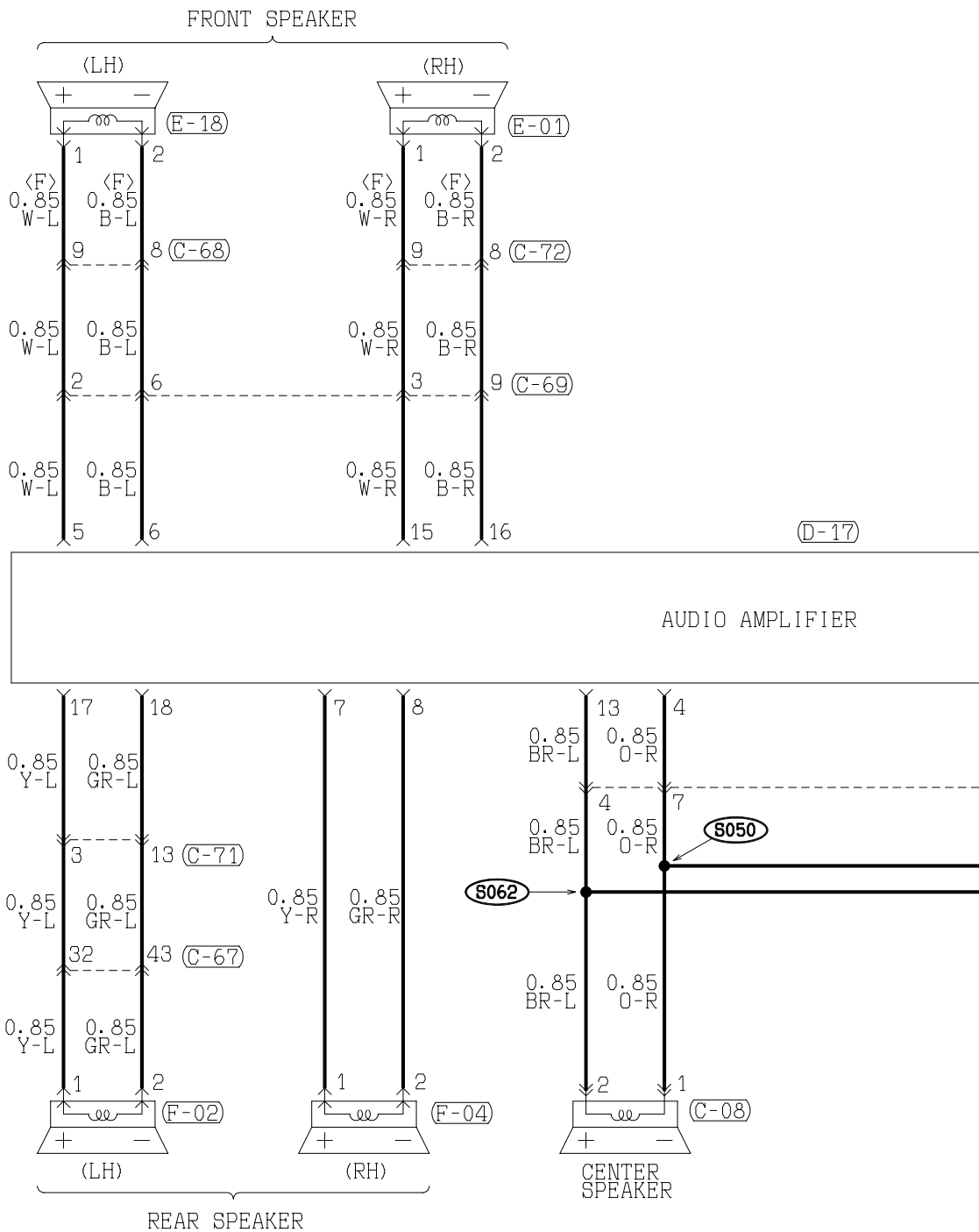

4

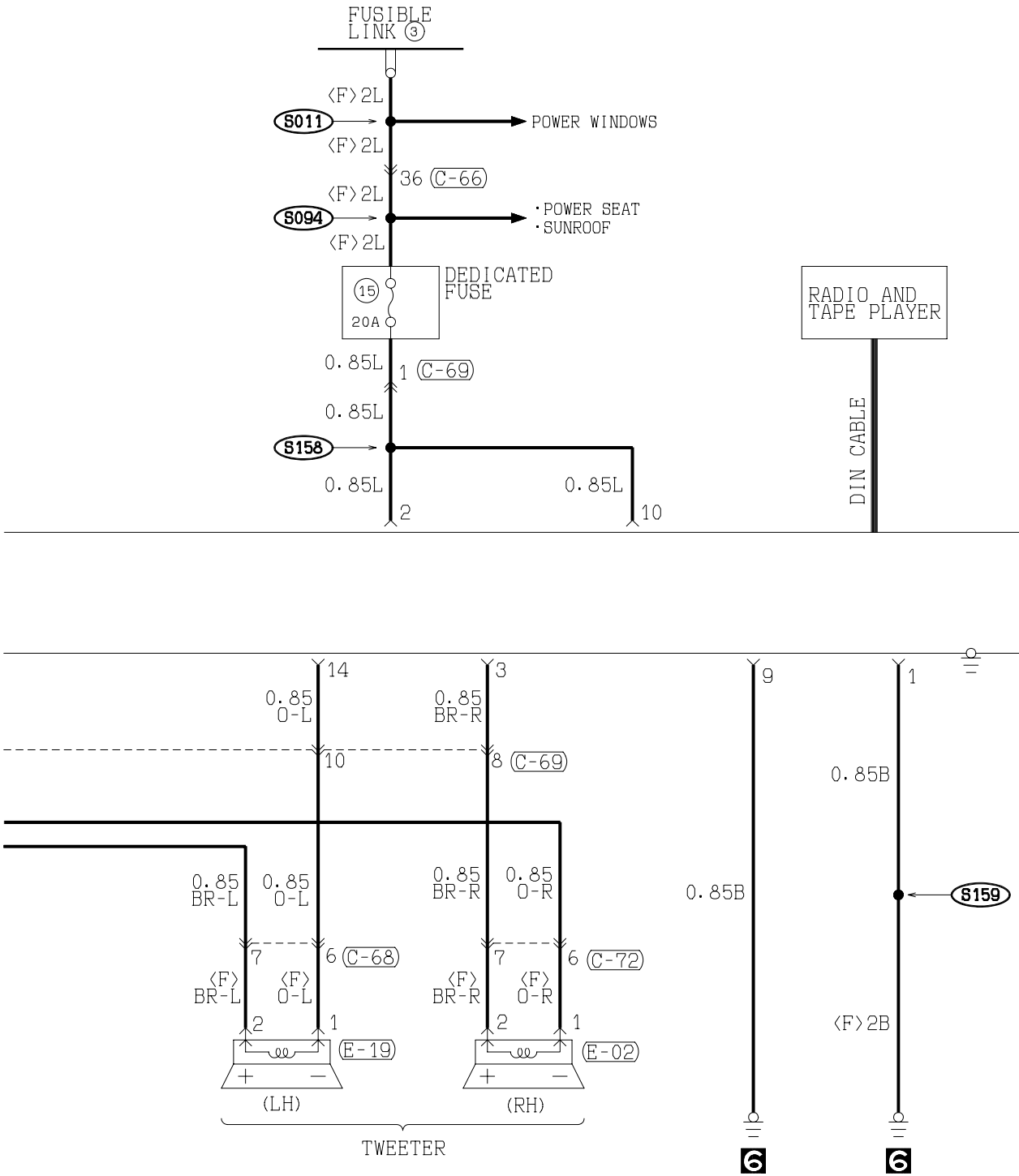

(C-71)
MU801461

1	2	3	4	5	6	7	8	9	10
11	12	13	14	15	16	17	18	19	20
21	22	23	24	25	26	27	28	29	30
31	32								

(C-72)

1	2	3	4	5	6	7	8	9
10	11	12	13	14	15	16	17	18
19	20	21	22	23	24	25	26	27
28	29	30	31	32				

(D-17)
(MU803726)

1	2	3	4	5	6	7	8
9	10	11	12	13	14	15	16
17	18						

(E-01)
MU801671

1
2

(E-02)

1	2
---	---

(E-18)
MU801671

1
2

(E-19)

1	2
---	---

(F-02)
MU801671

1
2

(F-04)
MU801671

1
2

WIRE COLOR CODE
 B : BLACK BR : BROWN G : GREEN GR : GRAY L : BLUE LG : LIGHT GREEN O : ORANGE
 P : PINK R : RED SB : SKY BLUE V : VIOLET W : WHITE Y : YELLOW

H1S14M06BB

TSB Revision

CIGARETTE LIGHTER

1

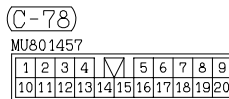
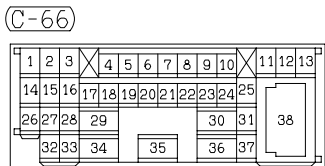
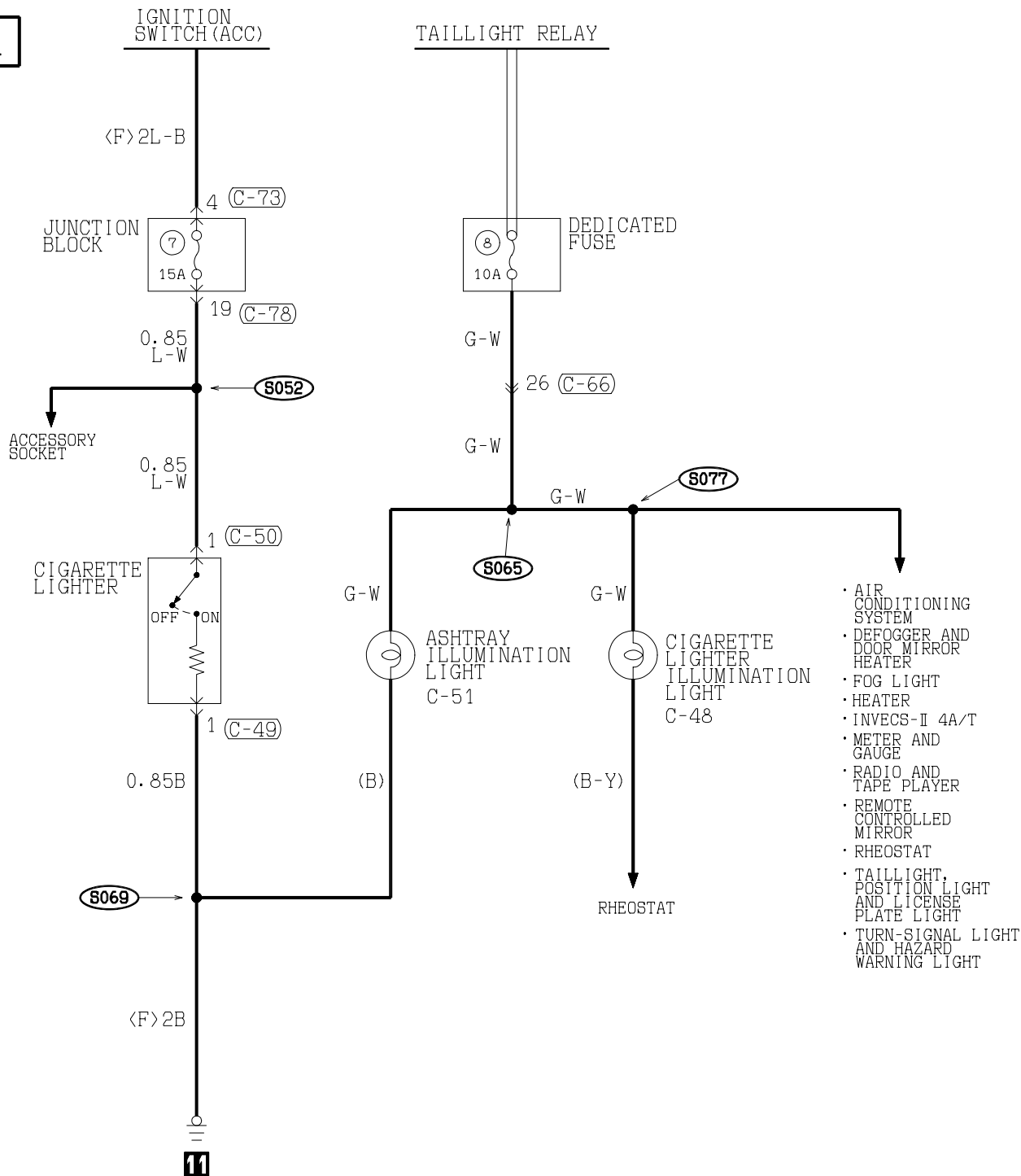

WIRE COLOR CODE

B : BLACK BR : BROWN
 L : BLUE LG : LIGHT GREEN
 R : RED SB : SKY BLUE
 Y : YELLOW

G : GREEN GR : GRAY
 O : ORANGE P : PINK
 V : VIOLET W : WHITE

H1S14M07AA

TSB Revision

ACCESSORY SOCKET

M1901007900057

1

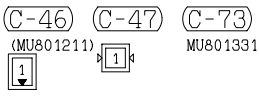
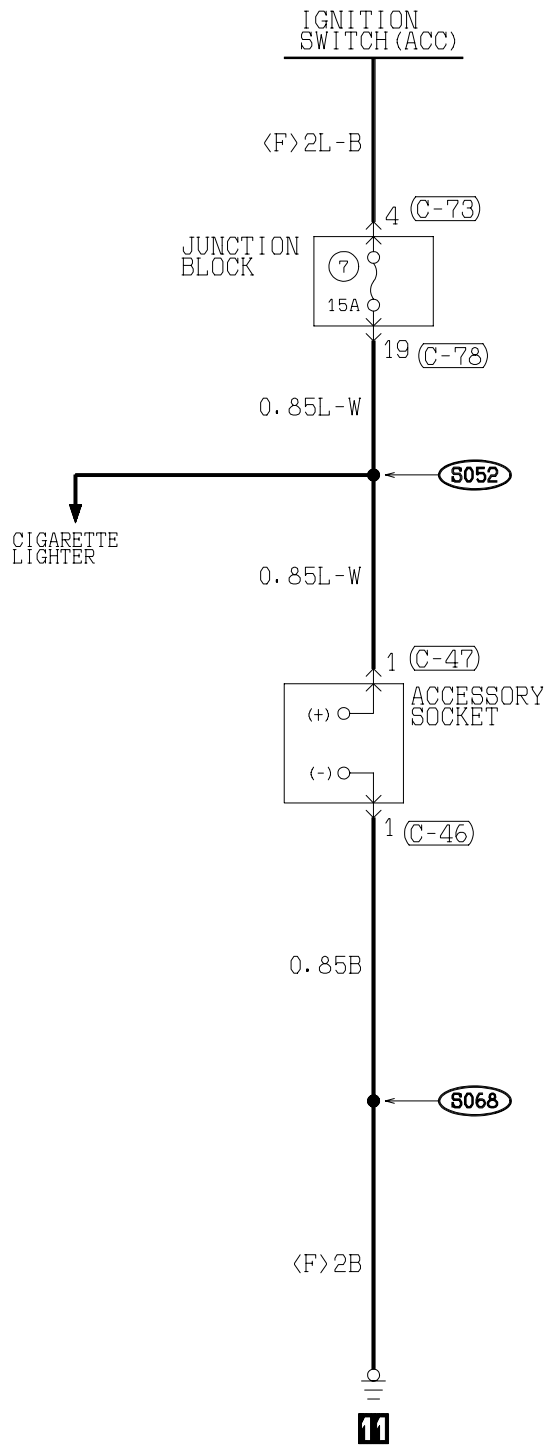

WIRE COLOR CODE
 B : BLACK BR: BROWN G : GREEN GR: GRAY L : BLUE LG: LIGHT GREEN O : ORANGE
 P : PINK R : RED SB: SKY BLUE V : VIOLET W : WHITE Y : YELLOW

H1S14M08AA

TSB Revision

SUNROOF

1

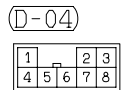
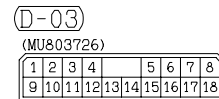
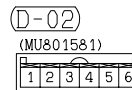
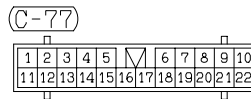
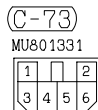
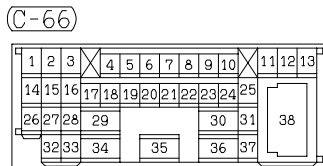
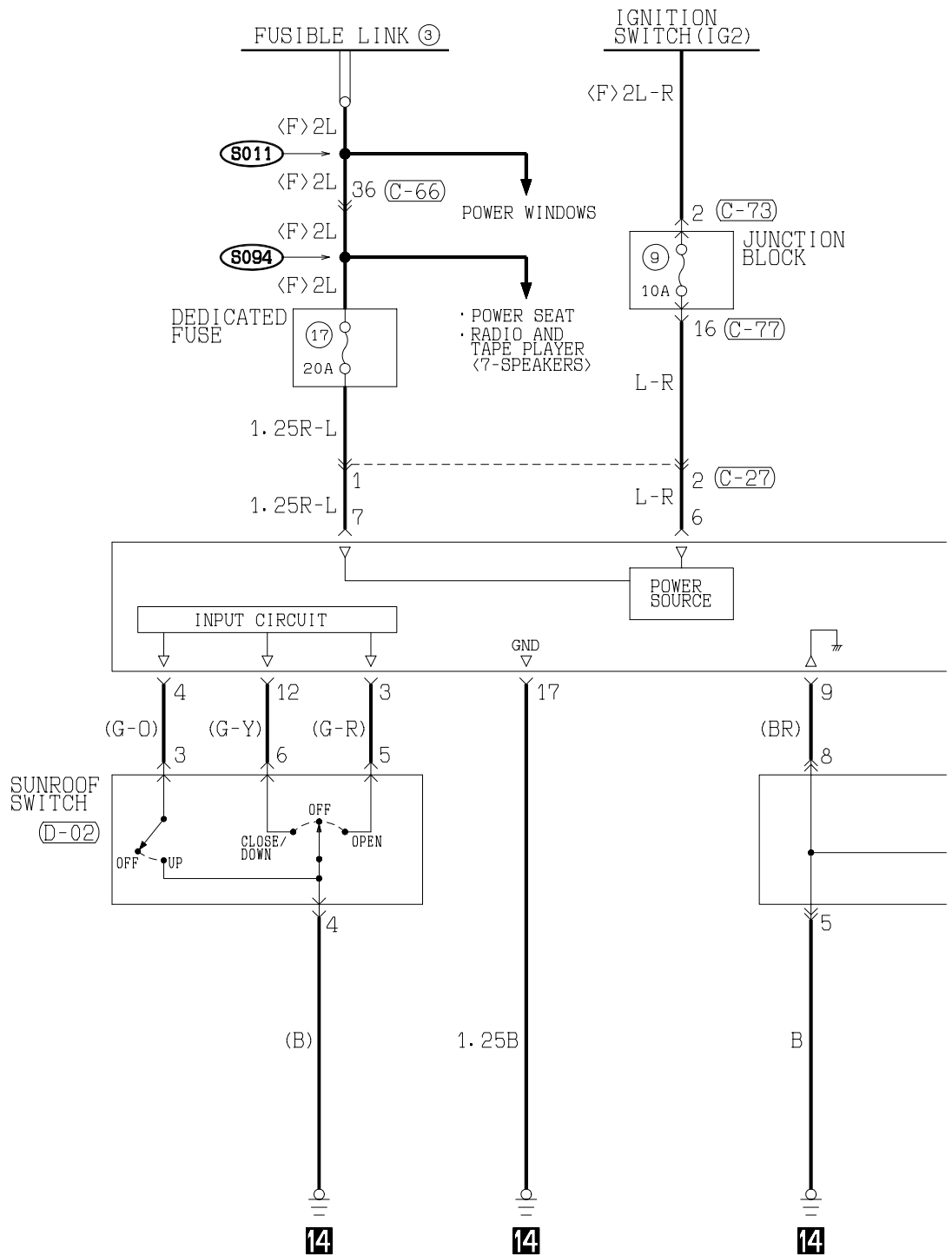

2

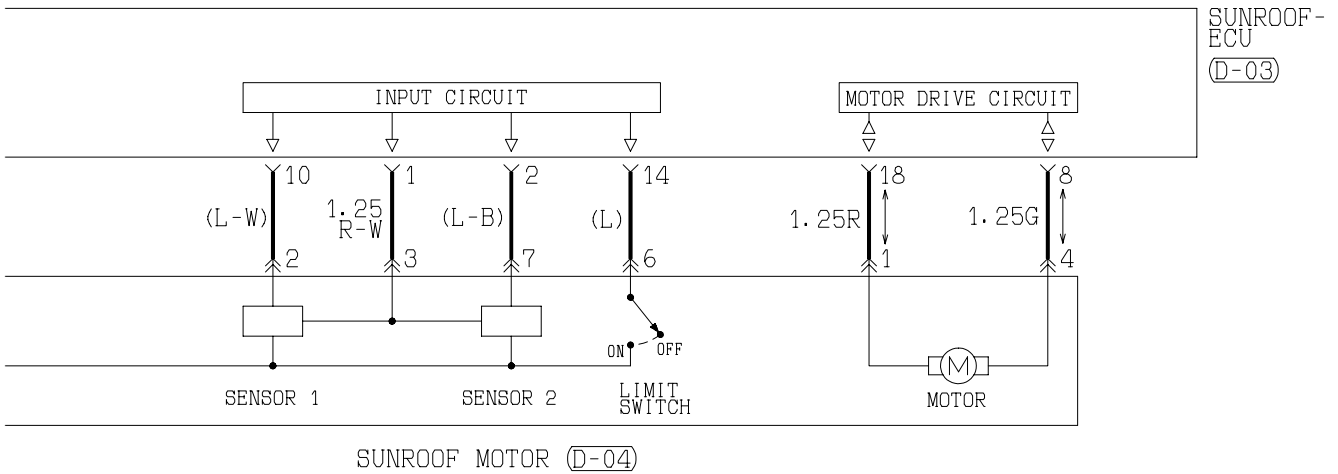

WIRE COLOR CODE
 B :BLACK BR:BROWN G :GREEN GR:GRAY L :BLUE LG:LIGHT GREEN O :ORANGE
 P :PINK R :RED SB:SKY BLUE V :VIOLET W :WHITE Y :YELLOW

H1S15M21AB

TSB Revision

LIGHTING MONITOR TONE ALARM

M1901011400044

1

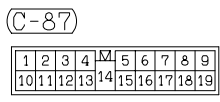
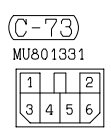
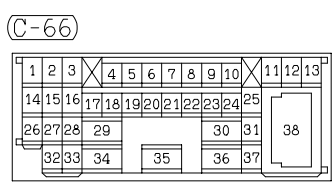
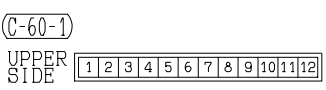
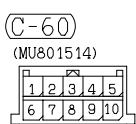
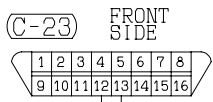
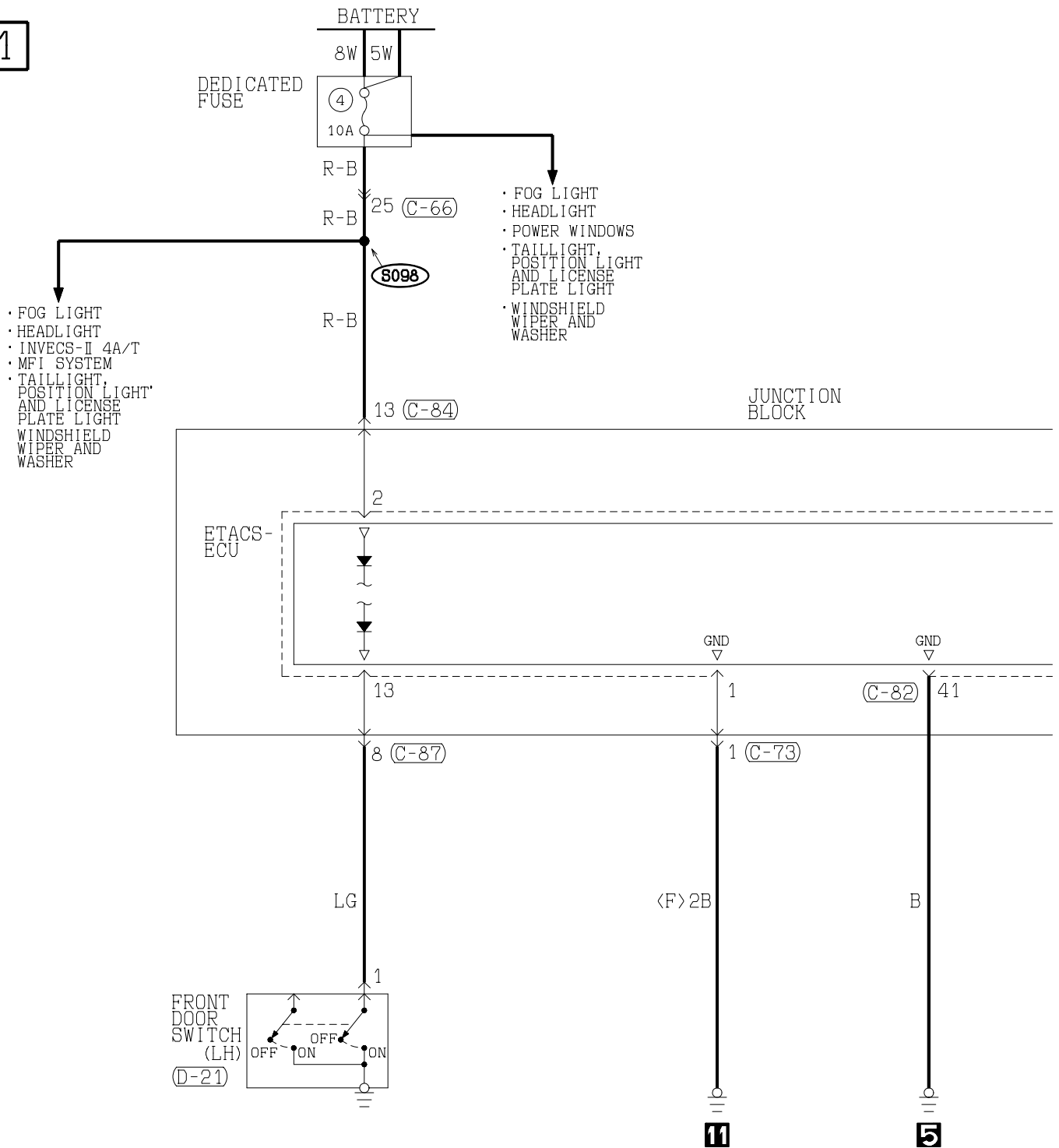

H1S15M22AA

TSB Revision

2

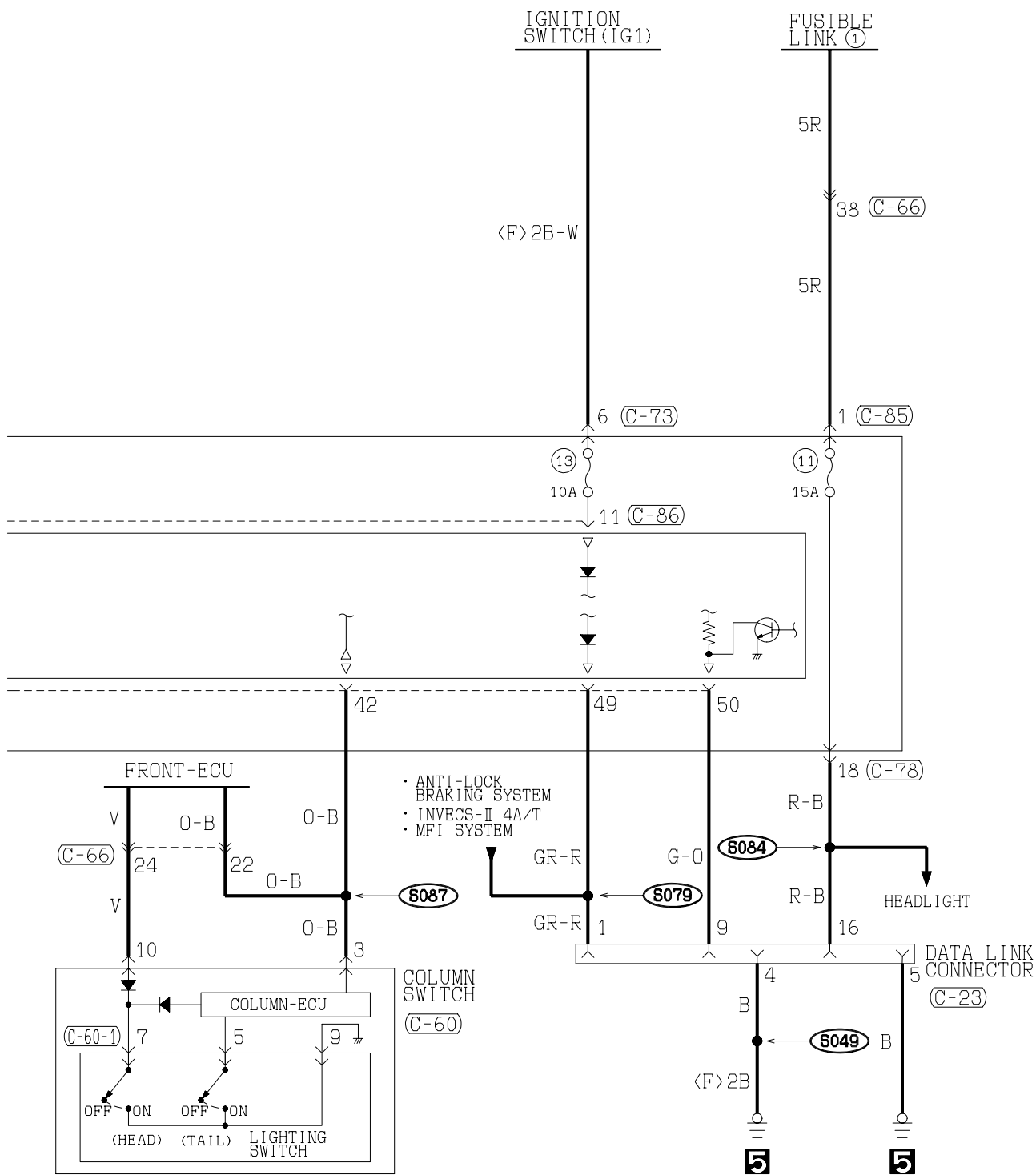

(C-78) MU801457

1	2	3	4	5	6	7	8	9
10	11	12	13	14	15	16	17	18
19	20							

(C-82) (MU801584)

41	42	43	44	45	46	47	48
49	50	51	52	53	54	55	56

(C-84)

1	2	3	4	5	6	7	8
9	10	11	12	13	14	15	16
17	18						

(C-85)

1

(C-86)

1	2	3	4	5	6	7	8	9	10	11	12	13	14	15	16	17	18	19	20
---	---	---	---	---	---	---	---	---	----	----	----	----	----	----	----	----	----	----	----

WIRE COLOR CODE
 B : BLACK BR : BROWN G : GREEN GR : GRAY L : BLUE LG : LIGHT GREEN O : ORANGE
 P : PINK R : RED SB : SKY BLUE V : VIOLET W : WHITE Y : YELLOW

H1S15M22AB

TSB Revision

KEY REMINDER TONE ALARM

M1901011300047

1

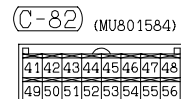
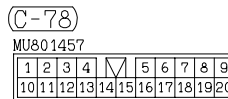
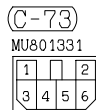
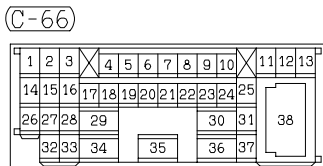
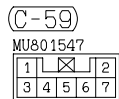
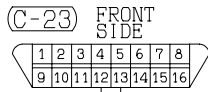
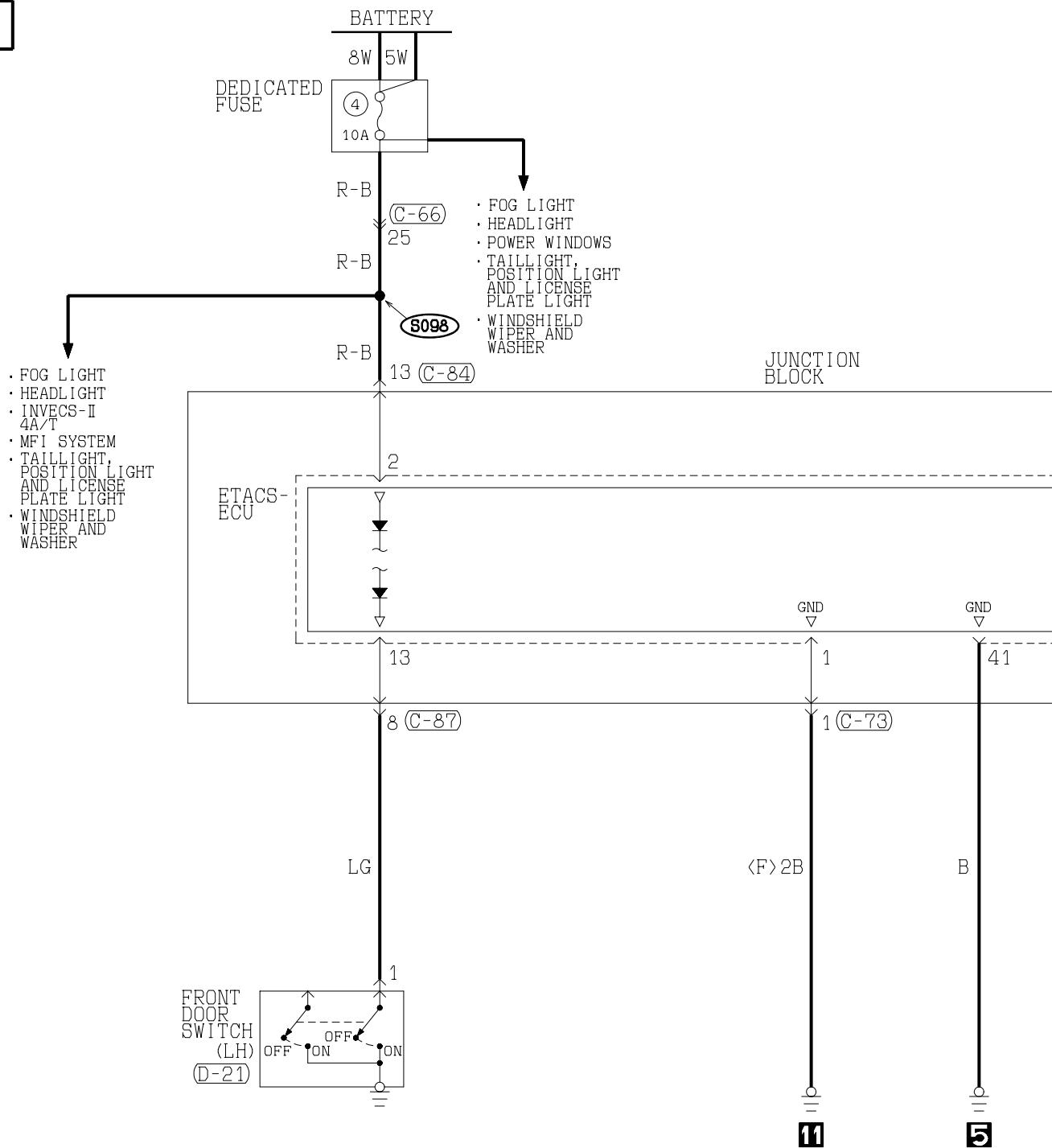

H1S15M23AA

TSB Revision

2

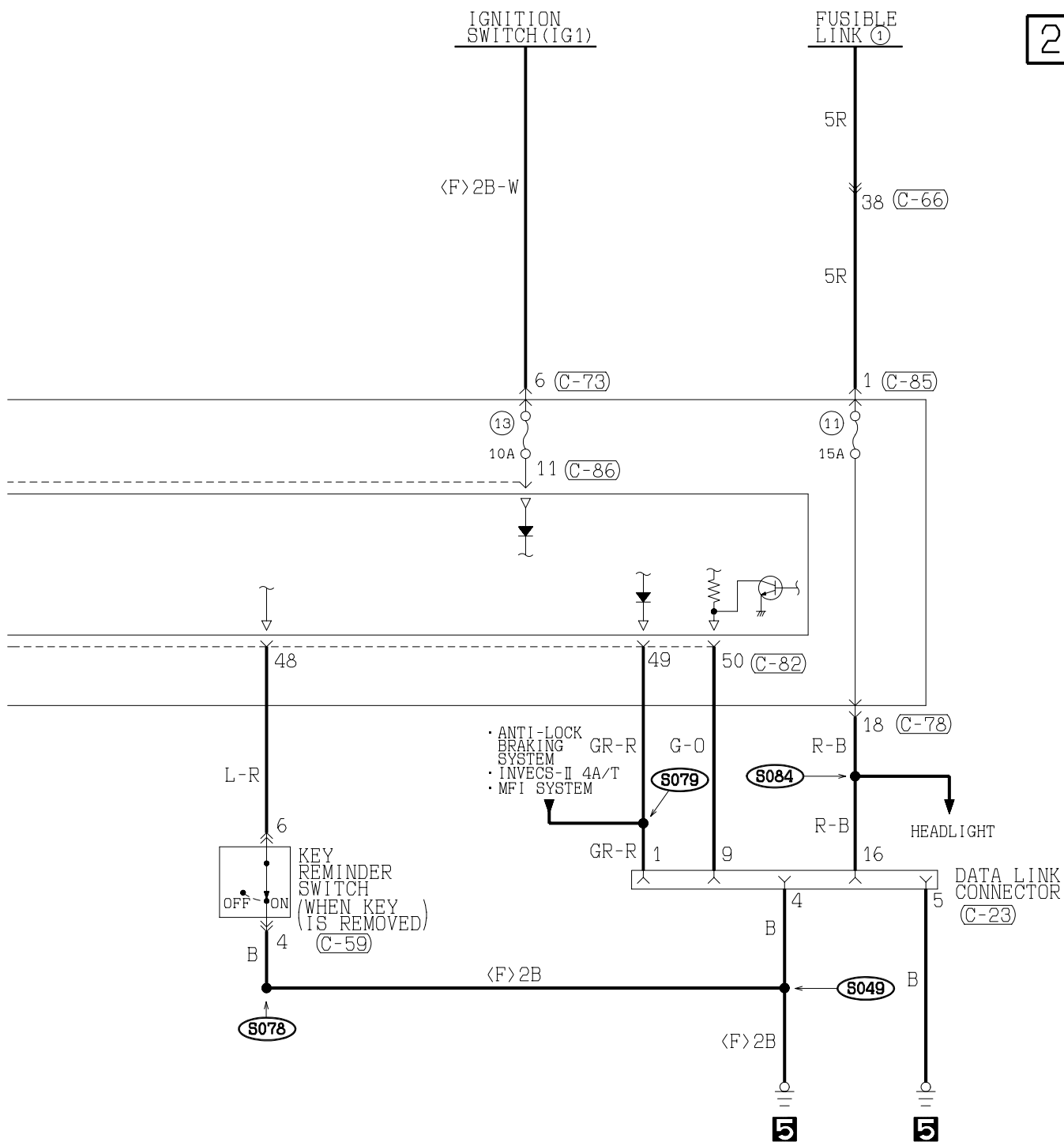

(C-84)

1	2	3	4	5	6	7	8		
9	10	11	12	13	14	15	16	17	18

(C-85)

1

(C-86)

1	2	3	4	5	6	7	8	9	10	11	12	13	14	15	16	17	18	19	20
---	---	---	---	---	---	---	---	---	----	----	----	----	----	----	----	----	----	----	----

(C-87)

1	2	3	4	5	6	7	8	9	
10	11	12	13	14	15	16	17	18	19

(D-21)

1	2	3
---	---	---

WIRE COLOR CODE

B : BLACK BR : BROWN G : GREEN GR : GRAY L : BLUE LG : LIGHT GREEN O : ORANGE
P : PINK R : RED SB : SKY BLUE V : VIOLET W : WHITE Y : YELLOW

H1S15M23AB

TSB Revision

SEAT BELT TONE ALARM

1

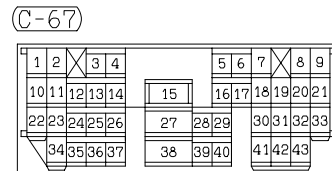
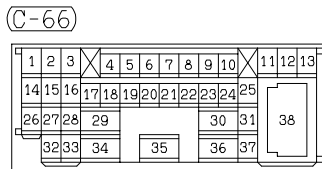
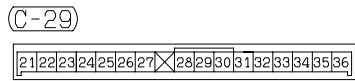
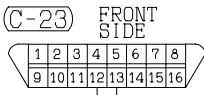
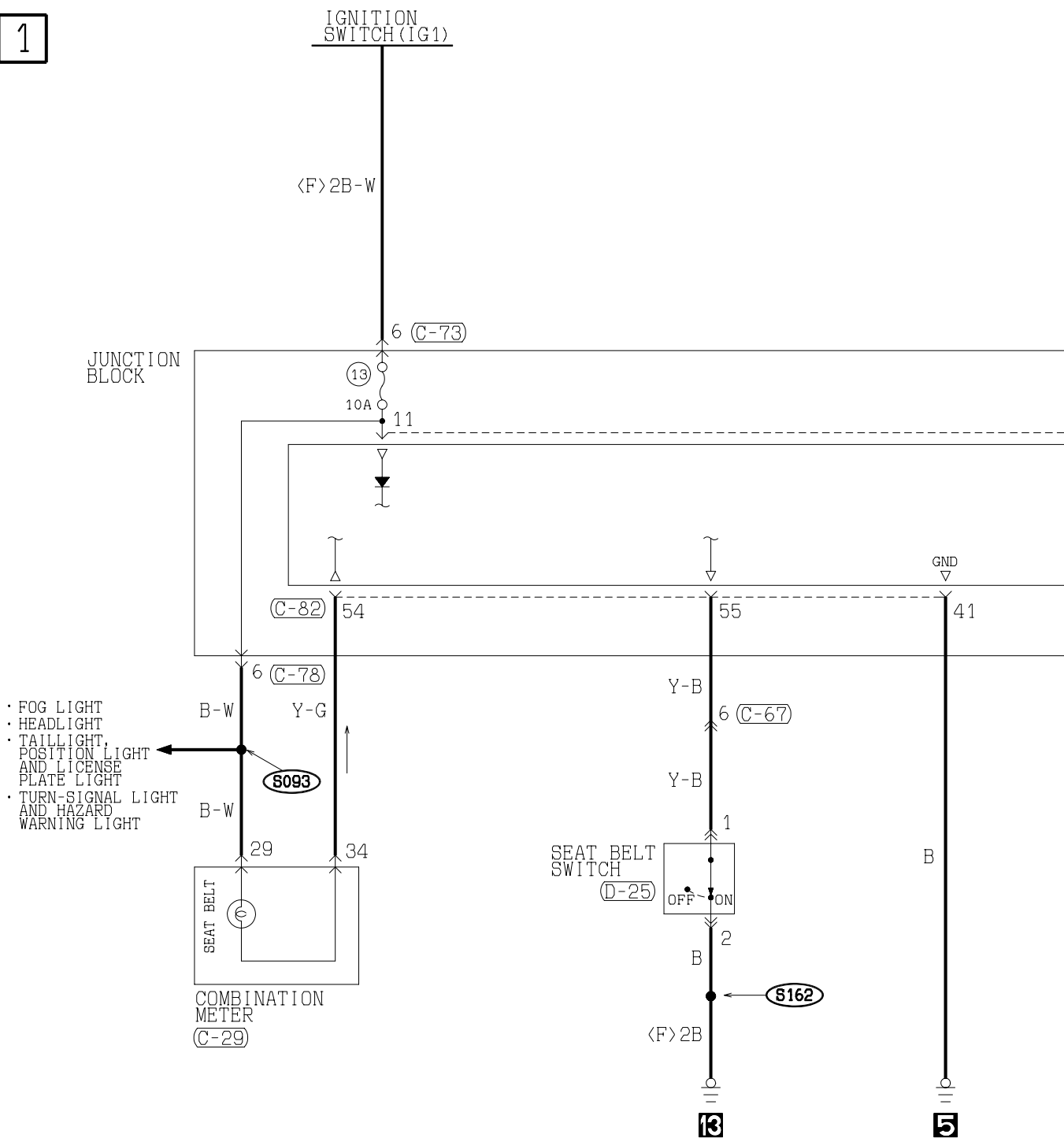

TSB Revision

2

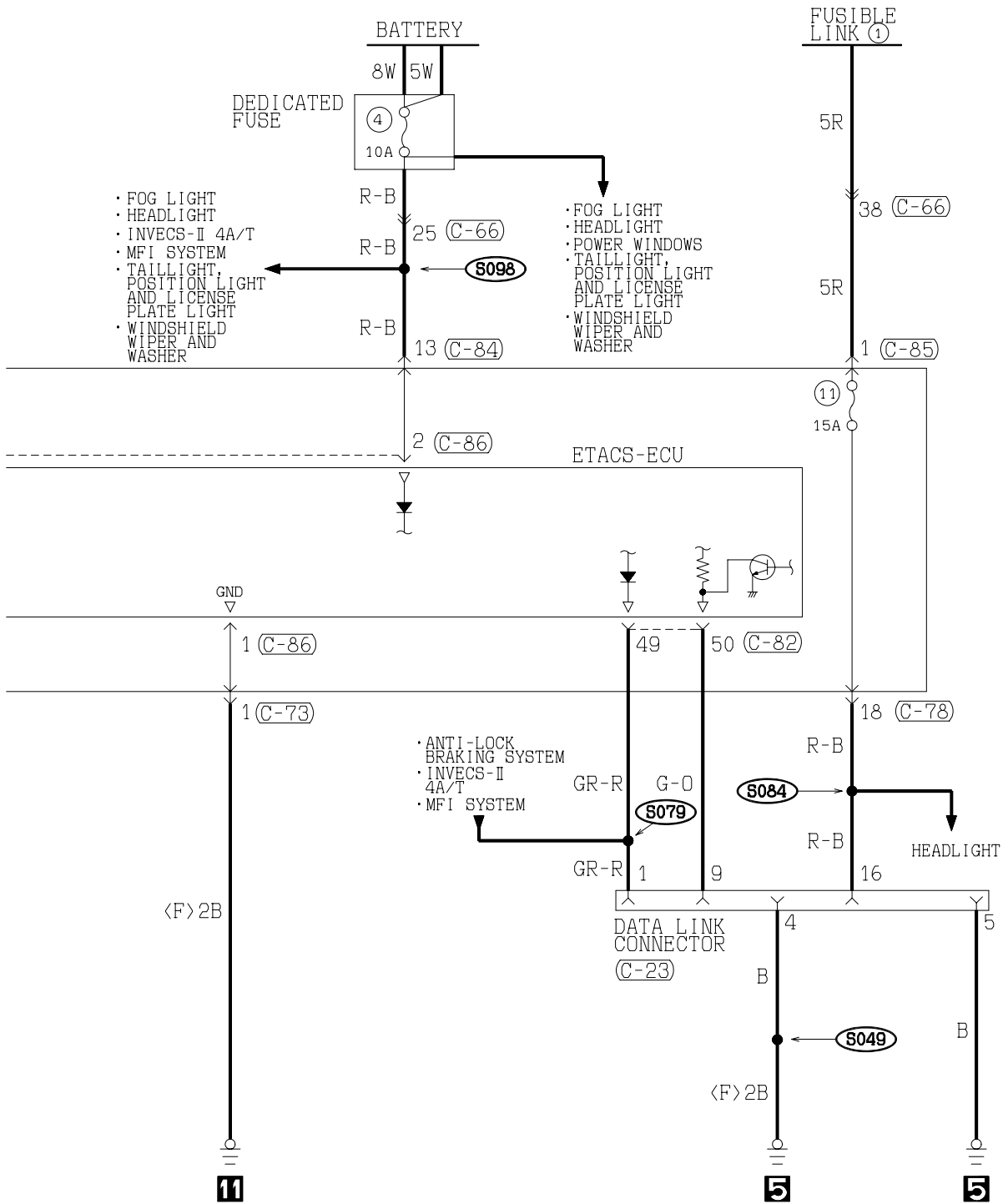

(C-73) MU801331

1	2
3	4
5	6

(C-78) MU801457

1	2	3	4	5	6	7	8	9
10	11	12	13	14	15	16	17	18
19	20							

(C-82) (MU801584)

41	42	43	44	45	46	47	48
49	50	51	52	53	54	55	56

(C-84)

1	2	3	4	5	6	7	8
9	10	11	12	13	14	15	16
17	18						

(C-85)

1

(C-86)

1	2	3	4	5	6	7	8	9	10	11	12	13	14	15	16	17	18	19	20
---	---	---	---	---	---	---	---	---	----	----	----	----	----	----	----	----	----	----	----

WIRE COLOR CODE
 B : BLACK BR : BROWN G : GREEN GR : GRAY L : BLUE LG : LIGHT GREEN O : ORANGE
 P : PINK R : RED SB : SKY BLUE V : VIOLET W : WHITE Y : YELLOW

H1S15M24AB

TSB Revision

AUTO-CRUISE CONTROL SYSTEM

M1901009300084

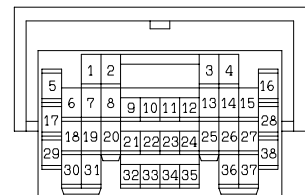
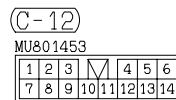
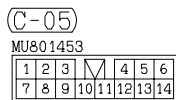
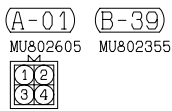
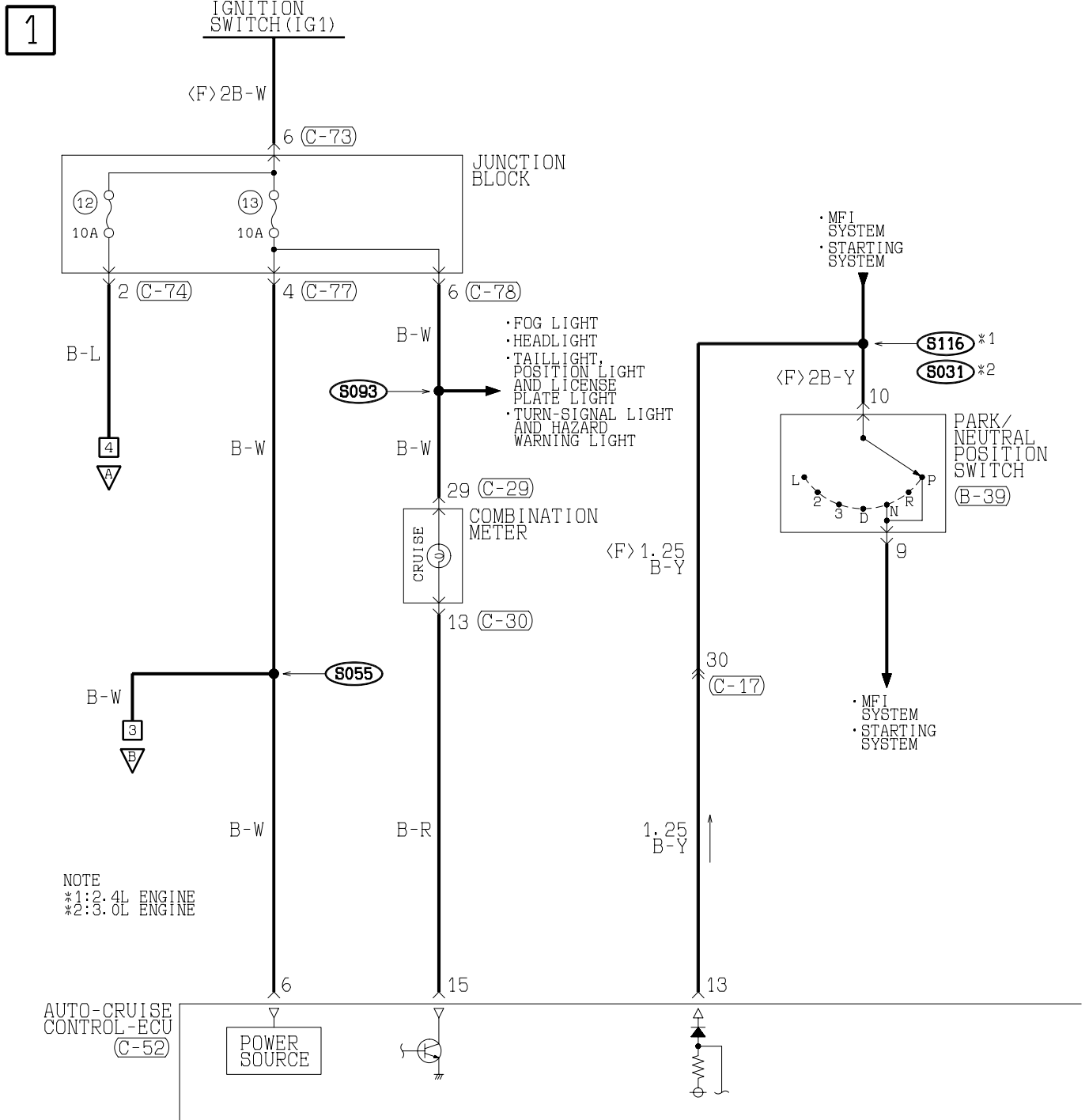

H1S15M25AA

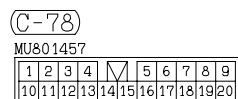
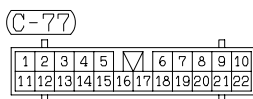
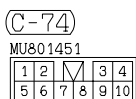

TSB Revision

2

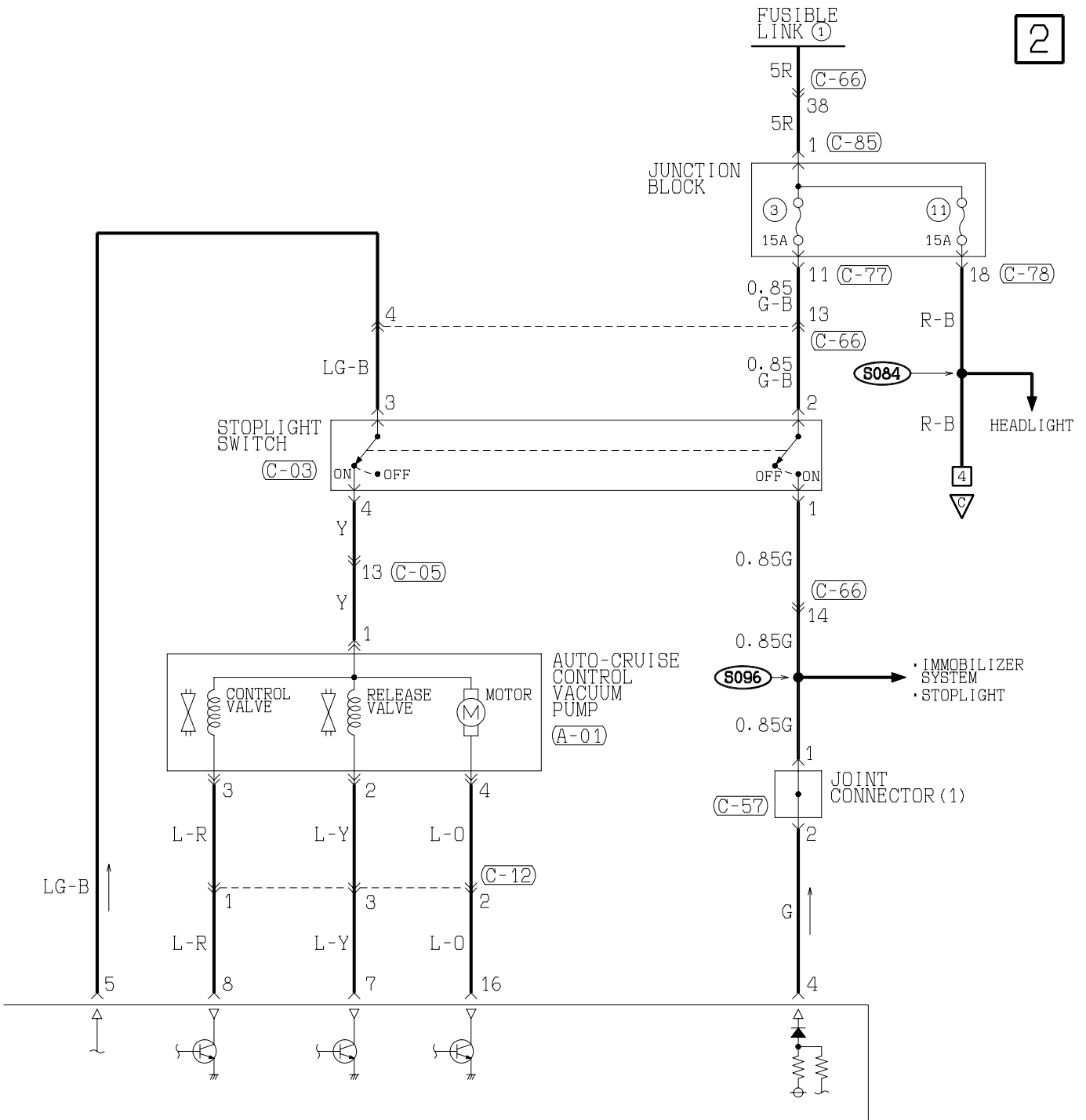

(C-29)

21	22	23	24	25	26	27	28	29	30	31	32	33	34	35	36
----	----	----	----	----	----	----	----	----	----	----	----	----	----	----	----

(C-30)

1	2	3	4	5	6	7	8	9	10	11	12	13	14	15	16
---	---	---	---	---	---	---	---	---	----	----	----	----	----	----	----

(C-52) (MU801584)

1	2	3	4	5	6	7	8
9	10	11	12	13	14	15	16

(C-57)

1	2	3	4	5	6	7	8	9	10	11
12	13	14	15	16	17	18	19	20	21	22
23	24	25	26	27	28	29	30	31	32	33

(C-66)

1	2	3	4	5	6	7	8	9	10	11	12	13
14	15	16	17	18	19	20	21	22	23	24	25	
26	27	28	29					30	31			
32	33	34						35	36	37		
											38	

(C-73) MU801331

1	2
3	4
5	6

WIRE COLOR CODE

B : BLACK BR : BROWN
 L : BLUE LG : LIGHT GREEN
 R : RED SB : SKY BLUE
 Y : YELLOW

G : GREEN GR : GRAY
 O : ORANGE P : PINK
 V : VIOLET W : WHITE

H1S15M25AB

TSB Revision

AUTO-CRUISE CONTROL SYSTEM (CONTINUED)

3

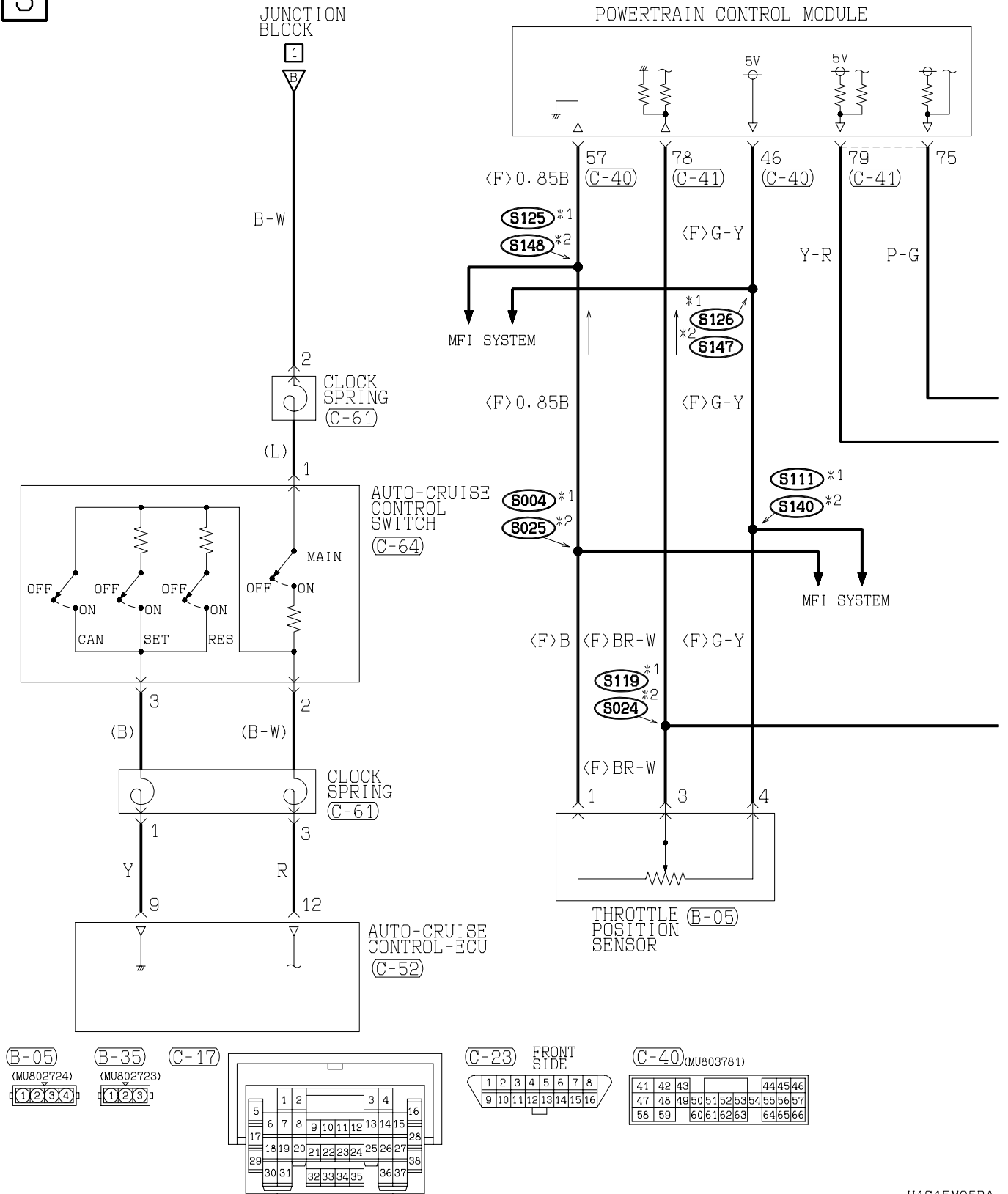

H1S15M25BA

TSB Revision

4

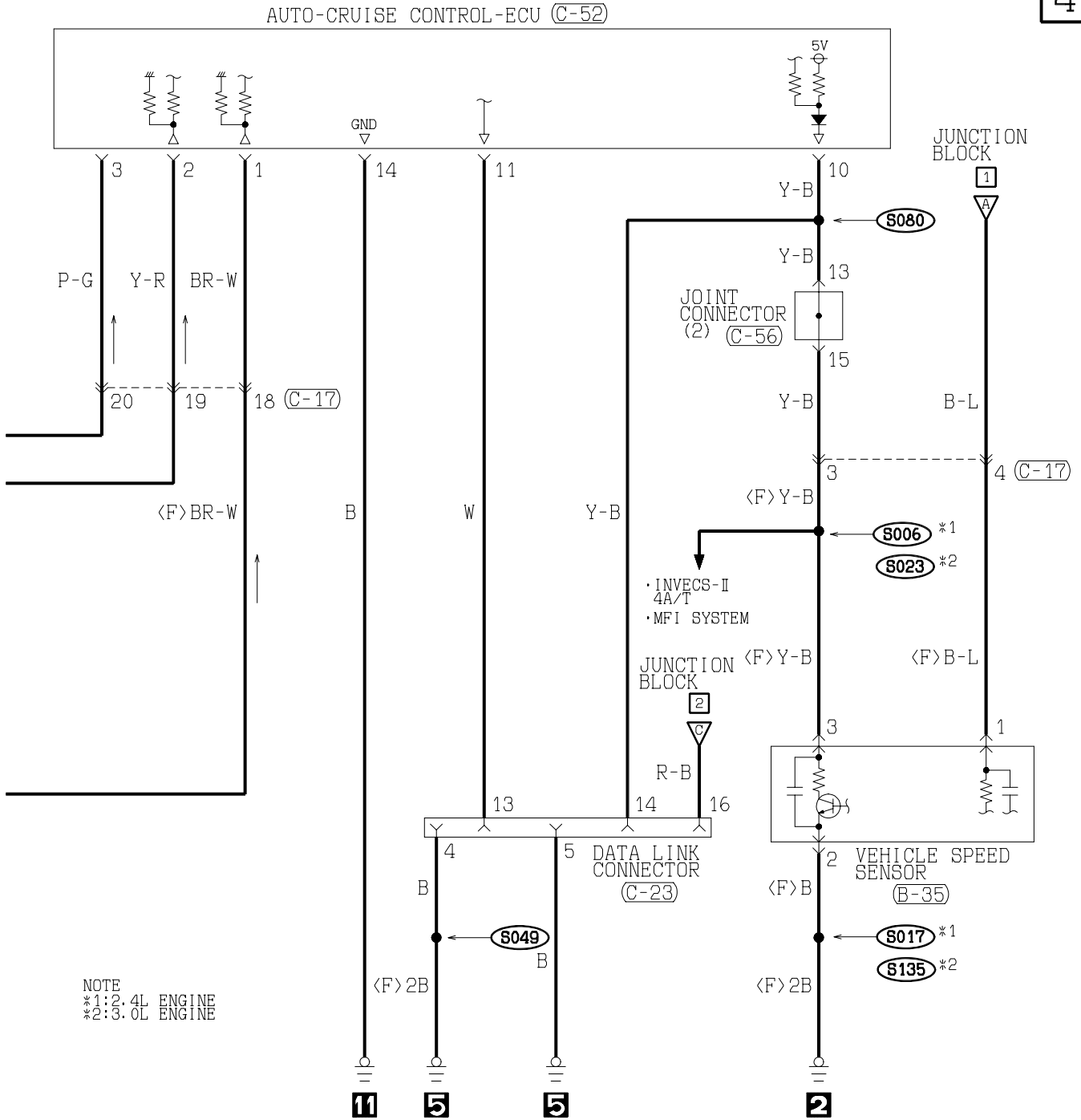

(C-41) (MU803783)

71	72	73	74	75	76	77
78	79	80	81	82	83	84
85	86	87	88	89	90	
91	92	93	94	95	96	97
98	99	100				

(C-52) (MU801584)

1	2	3	4	5	6	7	8
9	10	11	12	13	14	15	16

(C-56)

1	2	3	4	5	6	7	8	9	10	11
12	13	14	15	16	17	18	19	20	21	22
23	24	25	26	27	28	29	30	31	32	33

(C-61) (MU801691)

1	2	3	4
---	---	---	---

(C-64)

1	2	3
---	---	---

WIRE COLOR CODE
 B : BLACK BR: BROWN G : GREEN GR: GRAY L : BLUE LG: LIGHT GREEN O : ORANGE
 P : PINK R : RED SB: SKY BLUE V : VIOLET W : WHITE Y : YELLOW

H1S15M25BB

TSB Revision

ANTI-LOCK BRAKING SYSTEM (ABS) <VEHICLES WITHOUT TCL>

M1901008400066

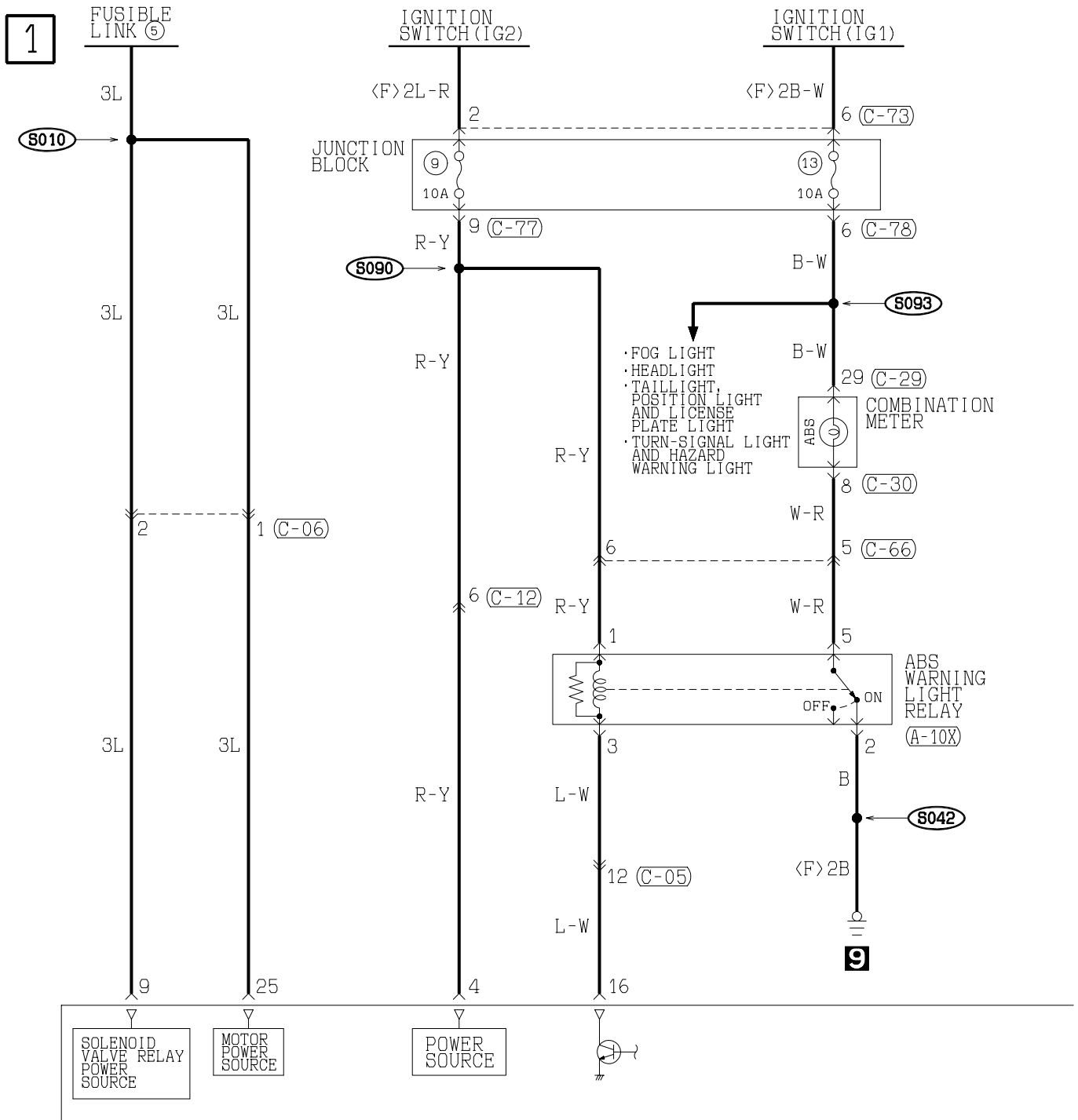

(A-03)

1	2	3	4	5	6	7	8	9
10	11	12	13	14	15	16	24	25
17	18	19	20	21	22	23		

(A-10X)

1	2	3
4		
5		

(C-03)

1	2
3	4

(C-05)

1	2	3	M	4	5	6	
7	8	9	10	11	12	13	14

(C-06)

1
2

(C-12)

1	2	3	M	4	5	6	
7	8	9	10	11	12	13	14

(C-13)

1	M	2	3	
4	5	6	7	8

(C-71)

1	2	3	4	5	M	6	7	8	9	10	
11	12	13	14	15	16	17	18	19	20	21	22

(C-73)

1	2		
3	4	5	6

(C-77)

1	2	3	4	5	M	6	7	8	9	10	
11	12	13	14	15	16	17	18	19	20	21	22

(C-78)

1	2	3	4	M	5	6	7	8	9	
10	11	12	13	14	15	16	17	18	19	20

(C-85)

1

H1S15M26AA

TSB Revision

2

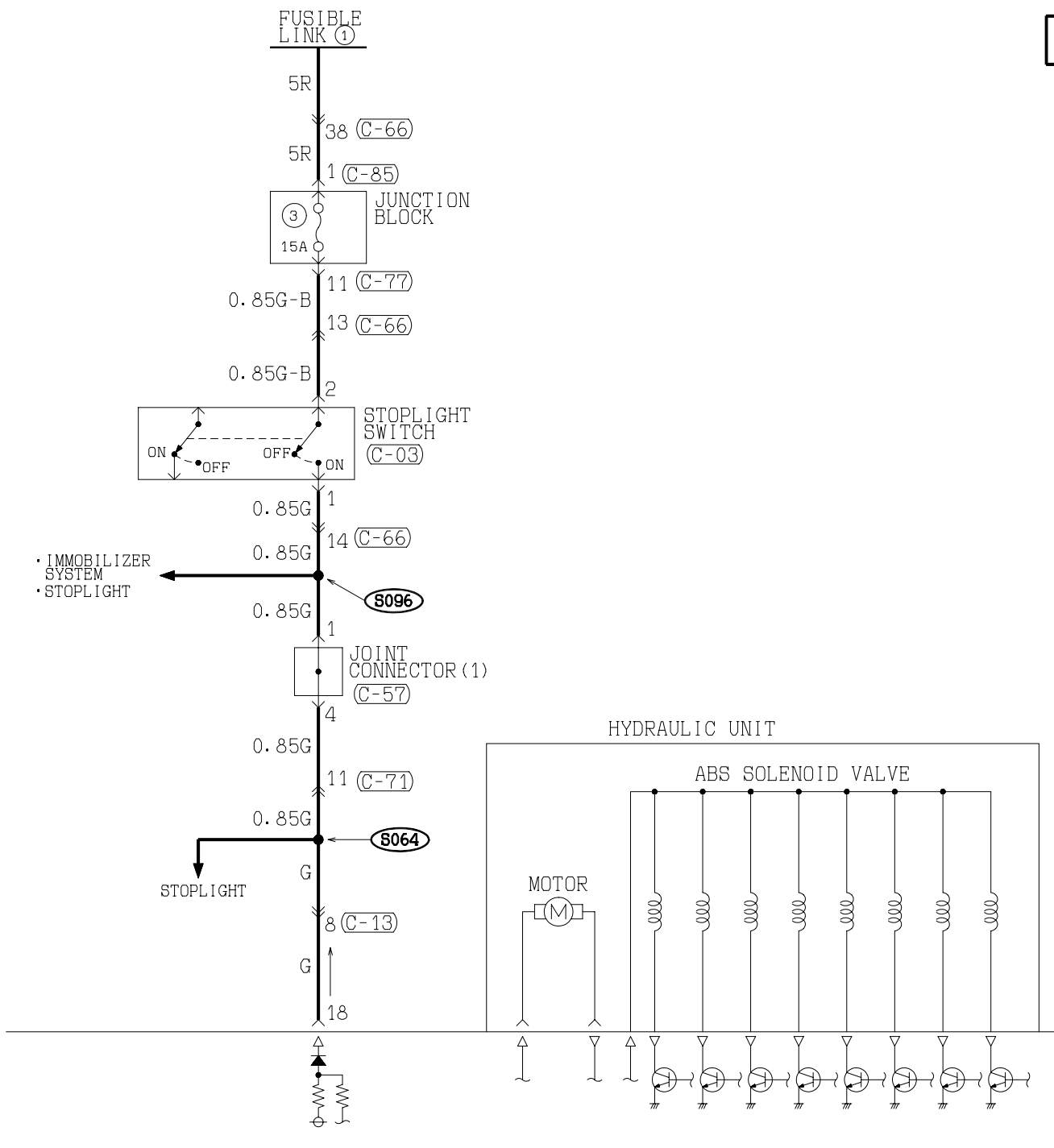

(C-29)

2	1	2	2	3	2	4	2	5	2	6	2	7	X	2	8	2	9	3	0	3	1	3	2	3	3	4	3	5	3	6
---	---	---	---	---	---	---	---	---	---	---	---	---	---	---	---	---	---	---	---	---	---	---	---	---	---	---	---	---	---	---

(C-30)

1	2	3	4	5	6	7	8	9	X	10	11	12	13	14	15	16
---	---	---	---	---	---	---	---	---	---	----	----	----	----	----	----	----

(C-57)

1	2	3	4	5	6	7	8	9	10	11
12	13	14	15	16	17	18	19	20	21	22
23	24	25	26	27	28	29	30	31	32	33

(C-66)

1	2	3	X	4	5	6	7	8	9	10	X	11	12	13
14	15	16	17	18	19	20	21	22	23	24	25	38		
26	27	28	29			30	31							
32	33	34	35	36	37									

WIRE COLOR CODE
 B : BLACK BR : BROWN
 P : PINK R : RED

G : GREEN GR : GRAY
 SB : SKY BLUE V : VIOLET

L : BLUE LG : LIGHT GREEN
 Y : YELLOW

O : ORANGE

H1S15M26AB

TSB Revision

ANTI-LOCK BRAKING SYSTEM (ABS) <VEHICLES WITHOUT TCL> (CONTINUED)

3

WHEEL SPEED SENSOR

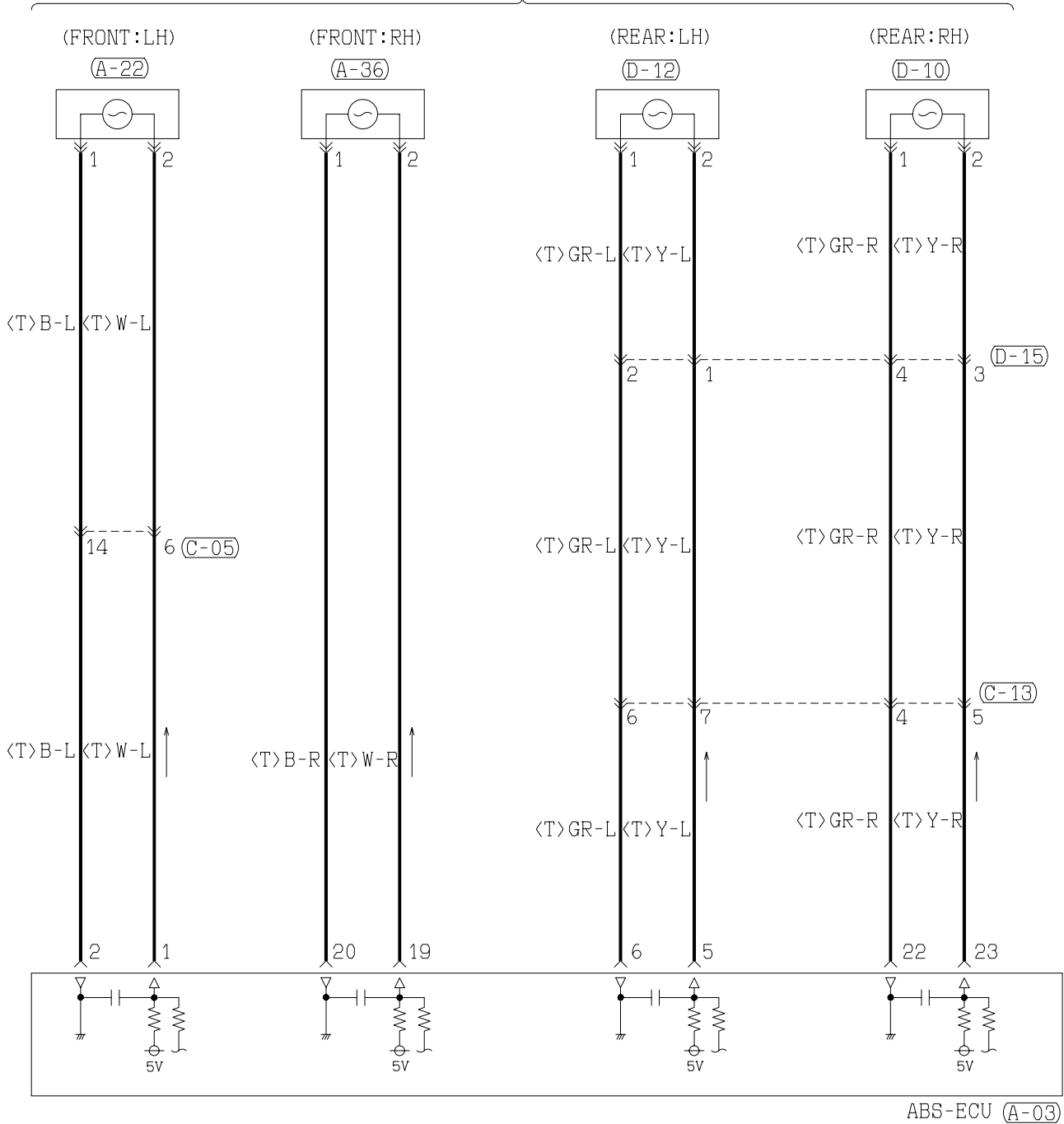

(A-03)

1	2	3	4	5	6	7	8	9
10	11	12	13	14	15	16		
17	18	19	20	21	22	23	24	25

(A-22)

1	2
---	---

(A-36)

1	2
---	---

(C-05)

1	2	3	4	5	6
7	8	9	10	11	12

(C-12)

1	2	3	4	5	6
7	8	9	10	11	12

(C-13)

1	2	3
4	5	6

(C-23)

1	2	3	4	5	6	7	8
9	10	11	12	13	14	15	16

TSB Revision

4

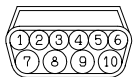
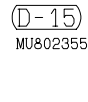
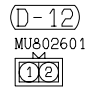
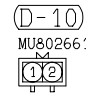
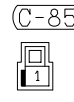
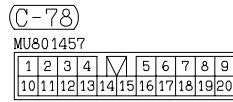
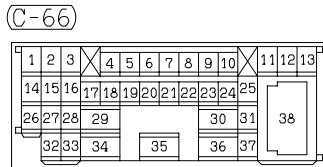
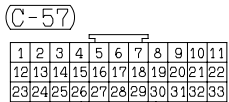
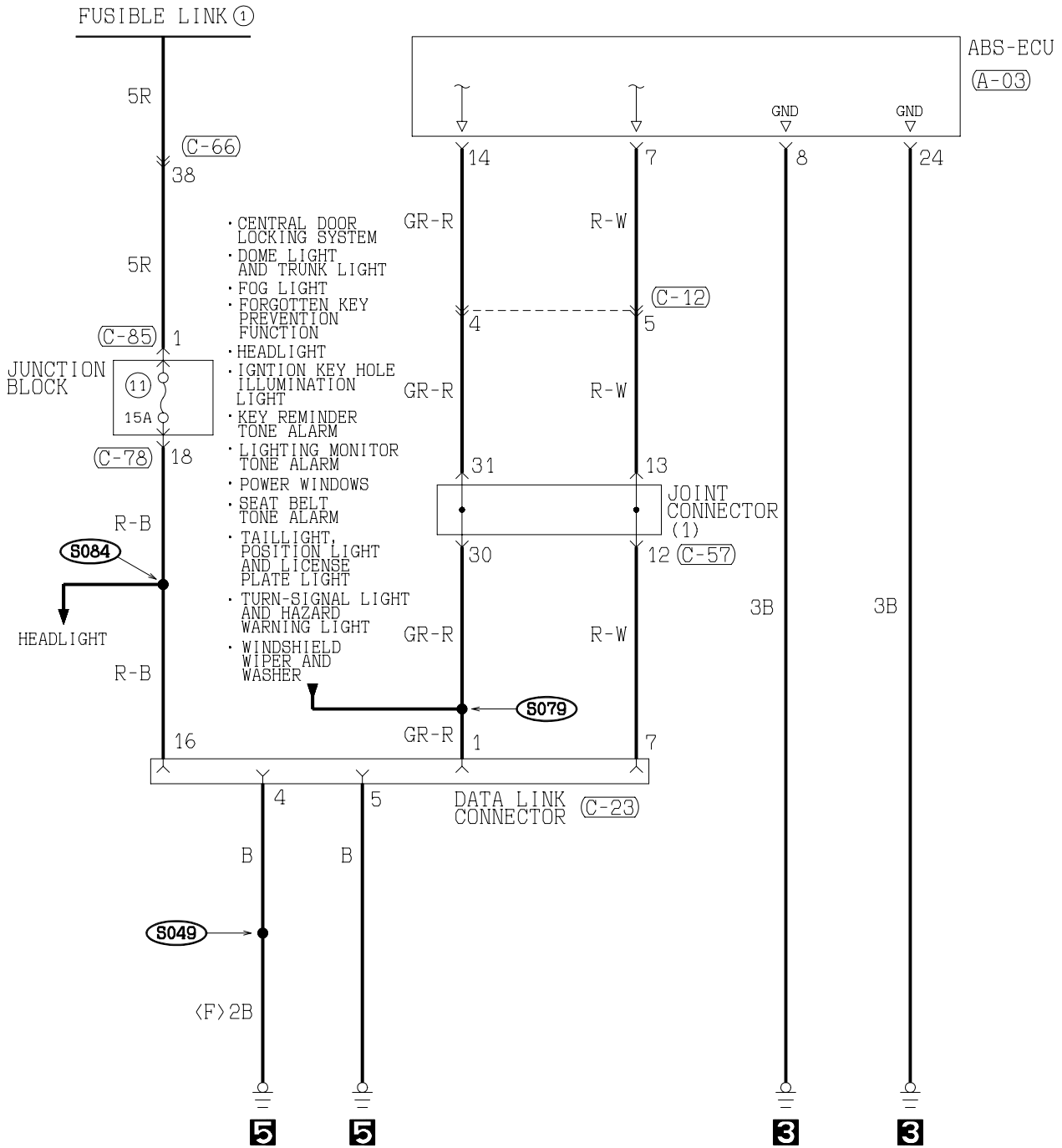

WIRE COLOR CODE
 B : BLACK BR : BROWN G : GREEN GR : GRAY L : BLUE LG : LIGHT GREEN O : ORANGE
 P : PINK R : RED SB : SKY BLUE V : VIOLET W : WHITE Y : YELLOW

H1S15M26BB

TSB Revision

ANTI-LOCK BRAKING SYSTEM (ABS) <VEHICLES WITH TCL>

M1901008400077

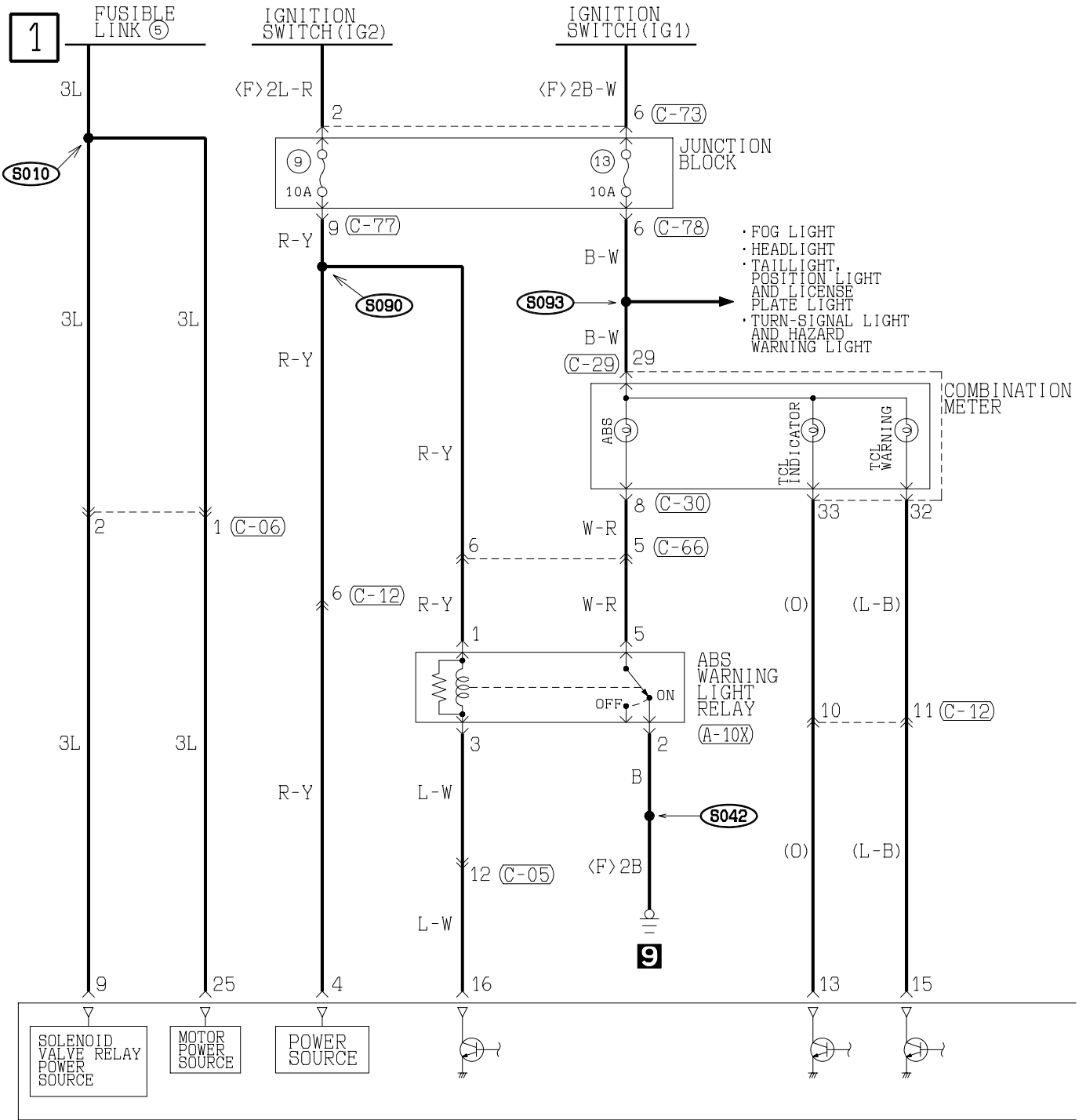

(A-03)

1	2	3	4	5	6	7	8	9
10	11	12	13	14	15	16	24	25
17	18	19	20	21	22	23		

(A-10X)

1	2	3
4		
5		

(C-03)

1	2
3	4

(C-05)

1	2	3	4	5	6
7	8	9	10	11	12
13	14				

(C-06)

1
2

(C-12)

1	2	3	4	5	6
7	8	9	10	11	12
13	14				

(C-13)

1	2	3
4	5	6
7	8	

(C-71)

1	2	3	4	5	6	7	8	9	10
11	12	13	14	15	16	17	18	19	20
21	22								

(C-73)

1	2
3	4
5	6

(C-77)

1	2	3	4	5	6	7	8	9	10
11	12	13	14	15	16	17	18	19	20
21	22								

(C-78)

1	2	3	4	5	6	7	8	9
10	11	12	13	14	15	16	17	18
19	20							

(C-85)

1

H1S15M27AA

TSB Revision

2

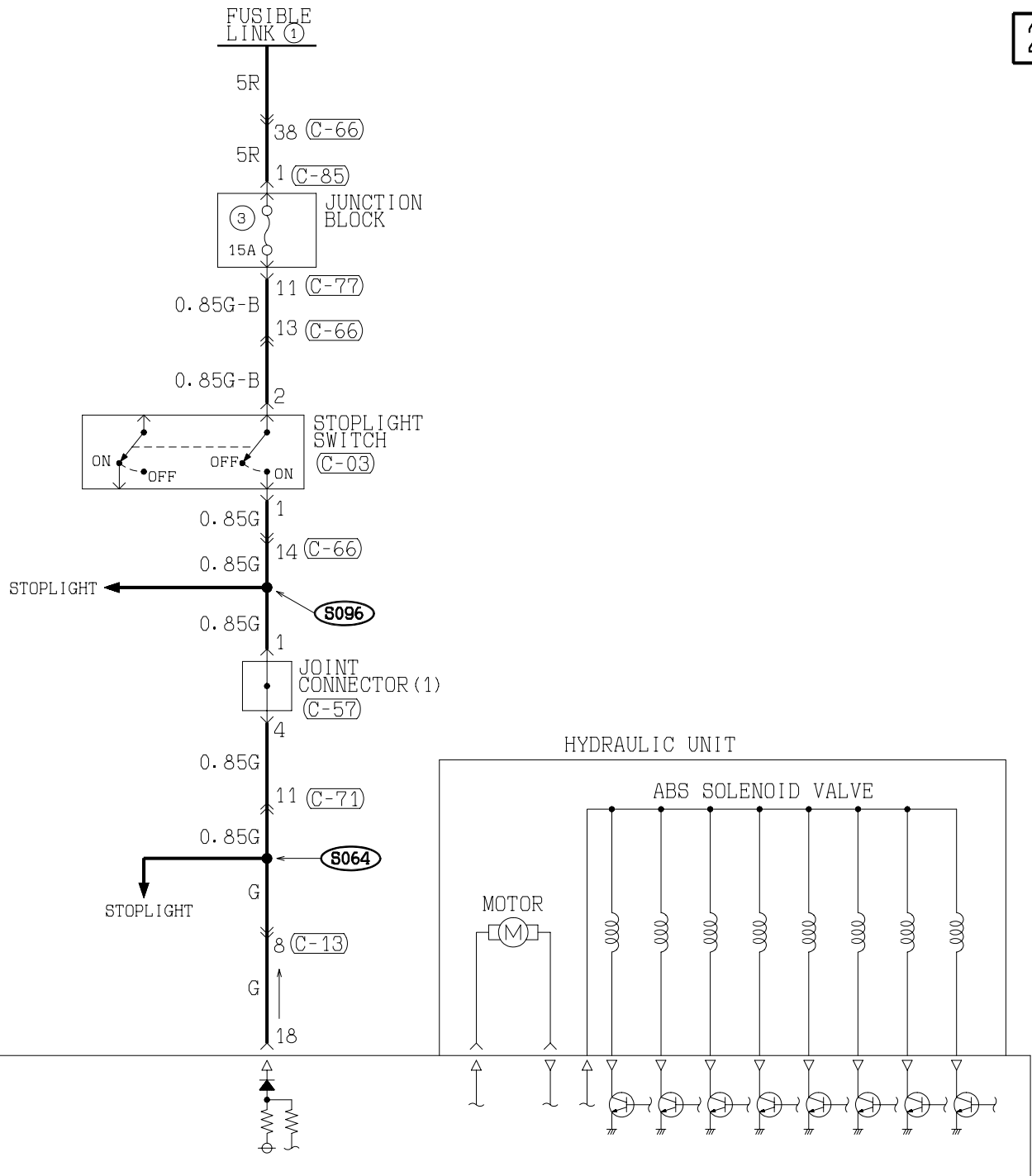

(C-29)

21	22	23	24	25	26	27	28	29	30	31	32	33	34	35	36
----	----	----	----	----	----	----	----	----	----	----	----	----	----	----	----

(C-30)

1	2	3	4	5	6	7	8	9	10	11	12	13	14	15	16
---	---	---	---	---	---	---	---	---	----	----	----	----	----	----	----

(C-57)

1	2	3	4	5	6	7	8	9	10	11
12	13	14	15	16	17	18	19	20	21	22
23	24	25	26	27	28	29	30	31	32	33

(C-66)

1	2	3	4	5	6	7	8	9	10	11	12	13
14	15	16	17	18	19	20	21	22	23	24	25	38
26	27	28	29	30	31	32	33	34	35	36	37	38

WIRE COLOR CODE
 B : BLACK BR : BROWN G : GREEN GR : GRAY L : BLUE LG : LIGHT GREEN O : ORANGE
 P : PINK R : RED SB : SKY BLUE V : VIOLET W : WHITE Y : YELLOW

H1S15M27AB

TSB Revision

ANTI-LOCK BRAKING SYSTEM <VEHICLES WITH TCL> (CONTINUED)

3

WHEEL SPEED SENSOR

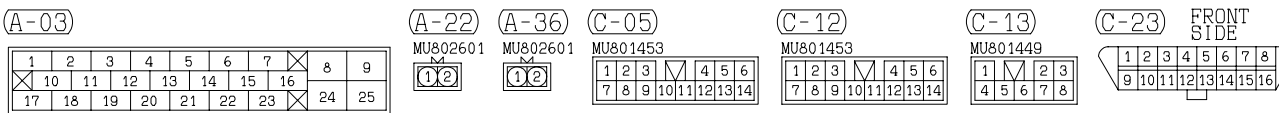
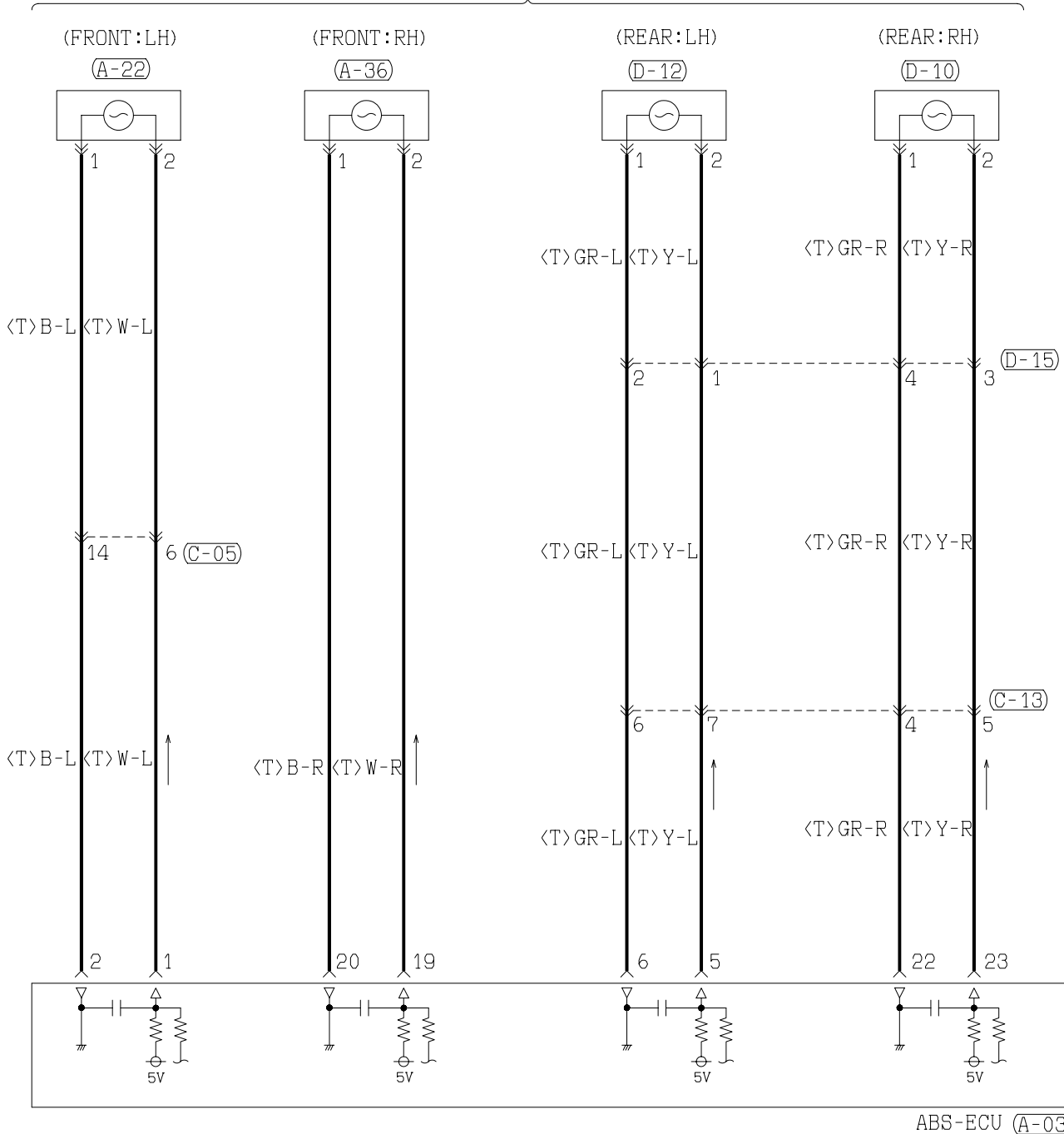

TSB Revision

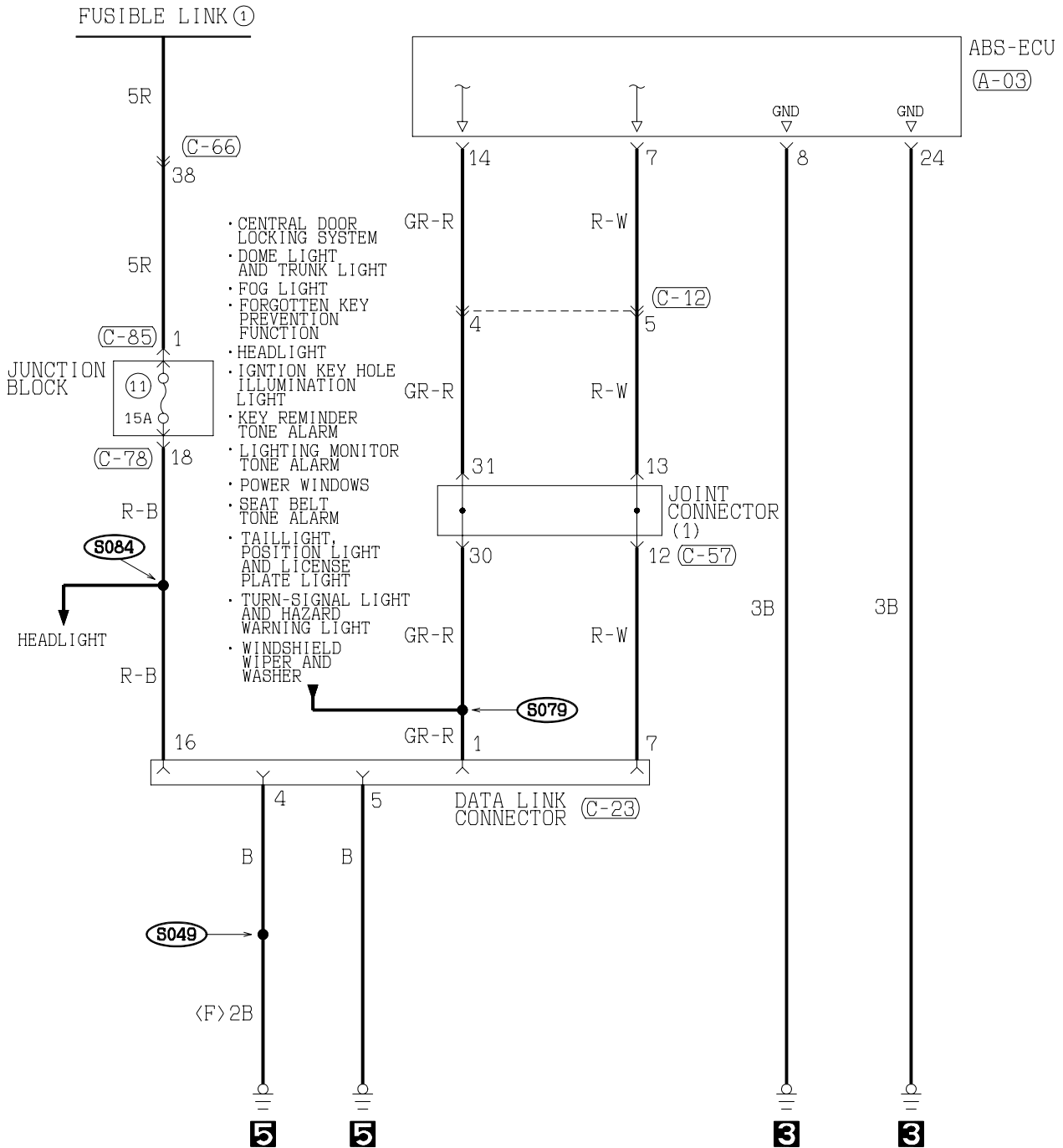

(C-57)

1	2	3	4	5	6	7	8	9	10	11
12	13	14	15	16	17	18	19	20	21	22
23	24	25	26	27	28	29	30	31	32	33

(C-66)

1	2	3	4	5	6	7	8	9	10	11	12	13
14	15	16	17	18	19	20	21	22	23	24	25	
26	27	28	29			30	31			38		
32	33	34				35	36	37				

(C-78)

1	2	3	4	5	6	7	8	9		
10	11	12	13	14	15	16	17	18	19	20

(C-85)



(D-10)



(D-12)



(D-15)



WIRE COLOR CODE
 B : BLACK
 P : PINK

BR : BROWN
 R : RED

G : GREEN
 SB : SKY BLUE

GR : GRAY
 V : VIOLET

L : BLUE
 W : WHITE

LG : LIGHT GREEN
 Y : YELLOW

O : ORANGE

H1S15M27BB

SUPPLEMENTAL RESTRAINT SYSTEM (SRS) <VEHICLES WITHOUT SIDE AIR BAG>

M1901009700059

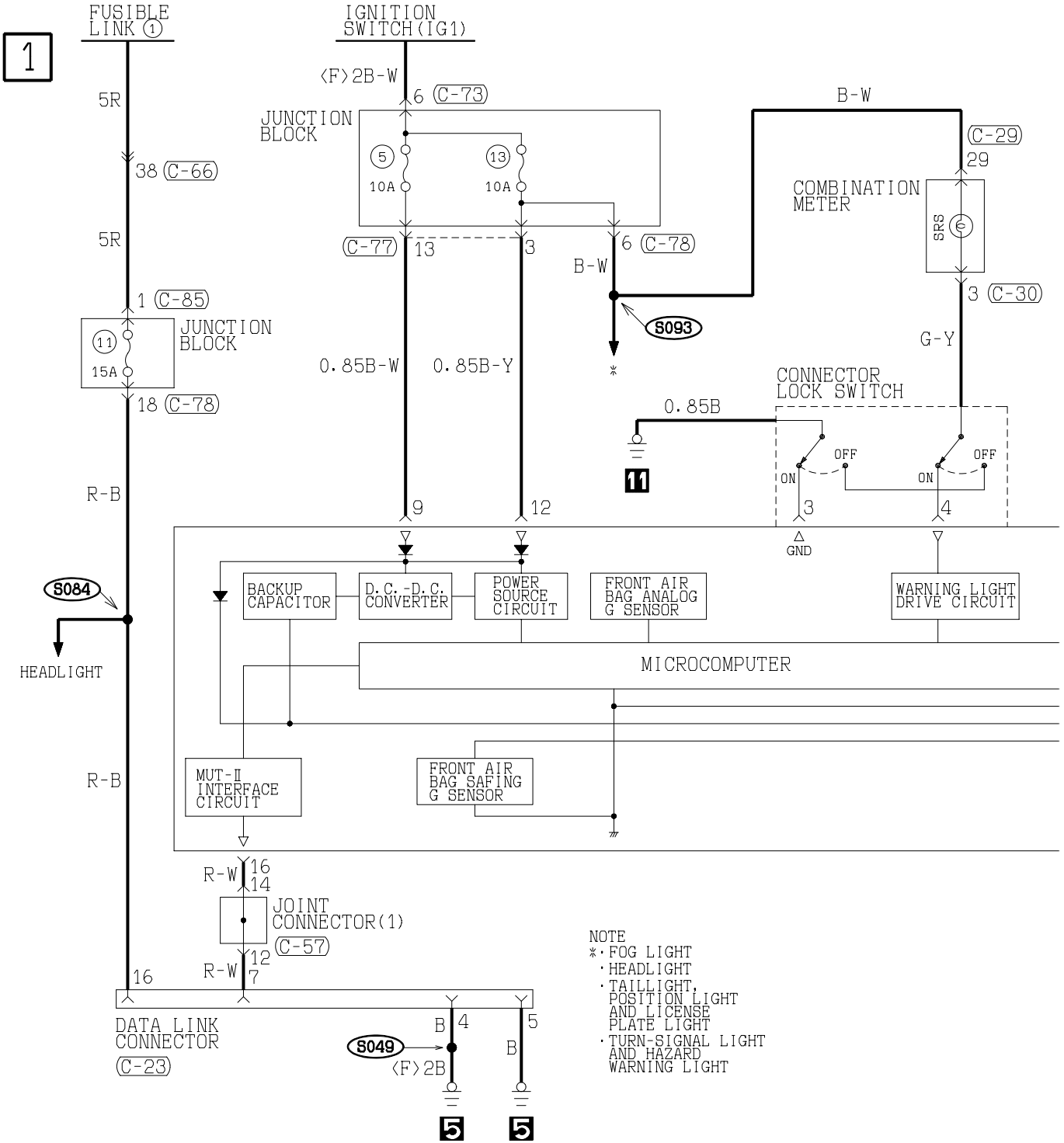

(C-09)



(C-23) FRONT SIDE

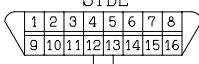

(C-29)

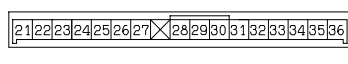

(C-30)

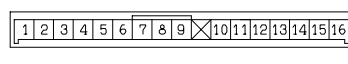

(C-44)

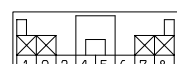

(C-78)

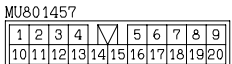

(C-85)



H1S15M28AA

2

(CONNECTOR COUPLED: ON
 CONNECTOR UNCOUPLED: OFF)
 CONNECTOR LOCK SWITCH

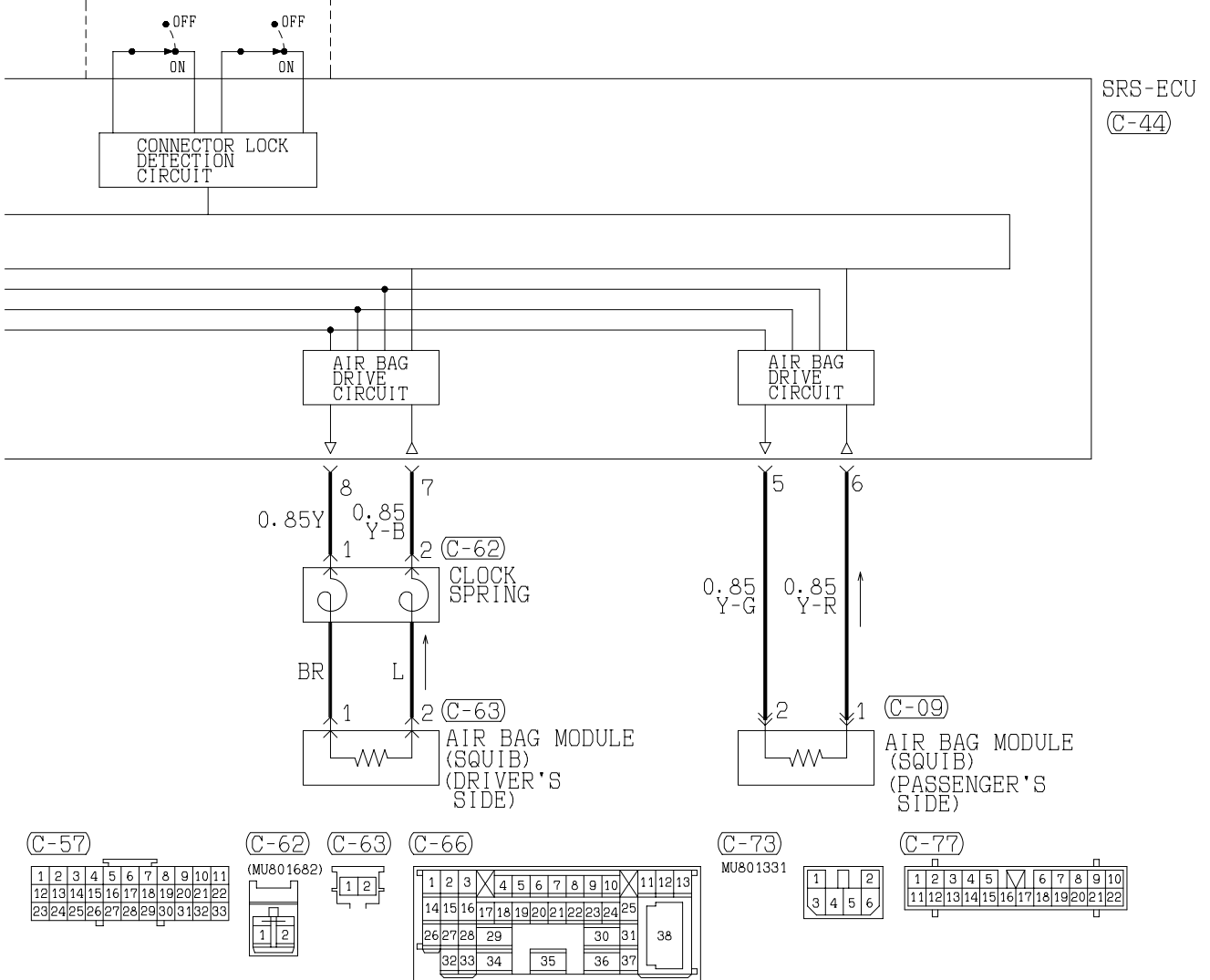

TSB Revision

SUPPLEMENTAL RESTRAINT SYSTEM (SRS) <VEHICLES WITH SIDE AIR BAG>

M1901009700060

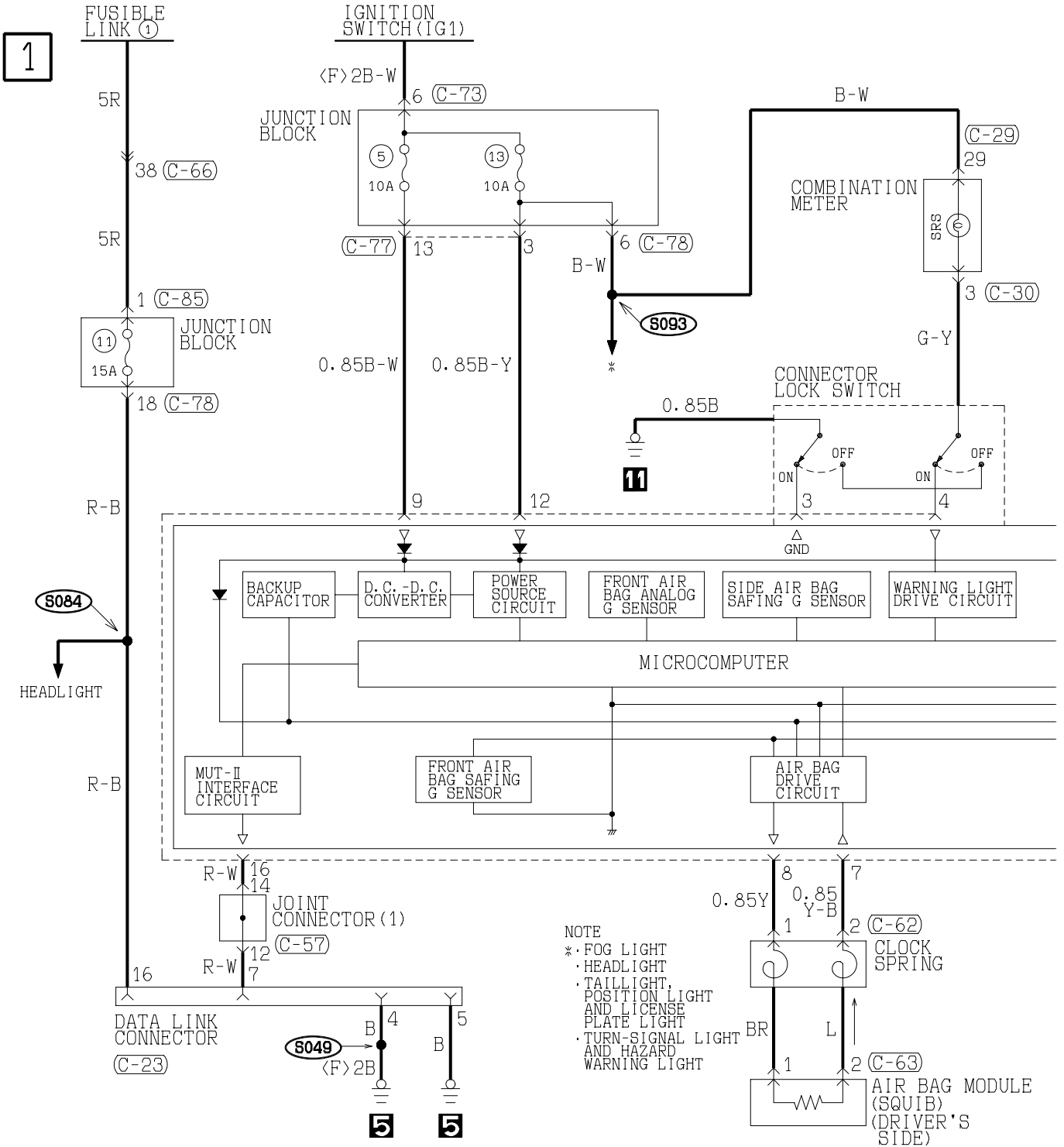

NOTE
 * FOG LIGHT
 * HEADLIGHT
 * TAILLIGHT,
 POSITION LIGHT
 AND LICENSE
 PLATE LIGHT
 * TURN-SIGNAL LIGHT
 AND HAZARD
 WARNING LIGHT

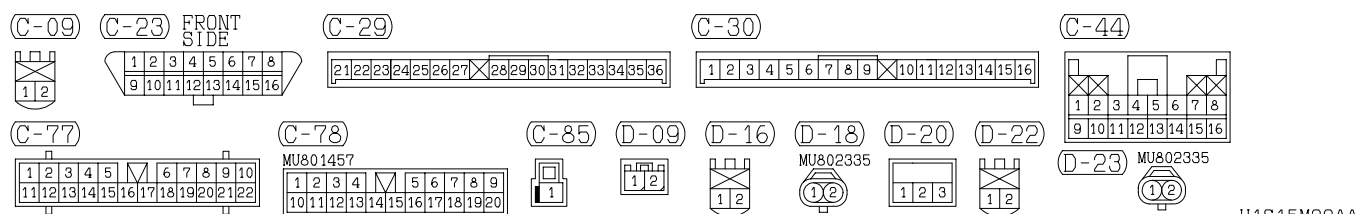

H1S15M29AA

2

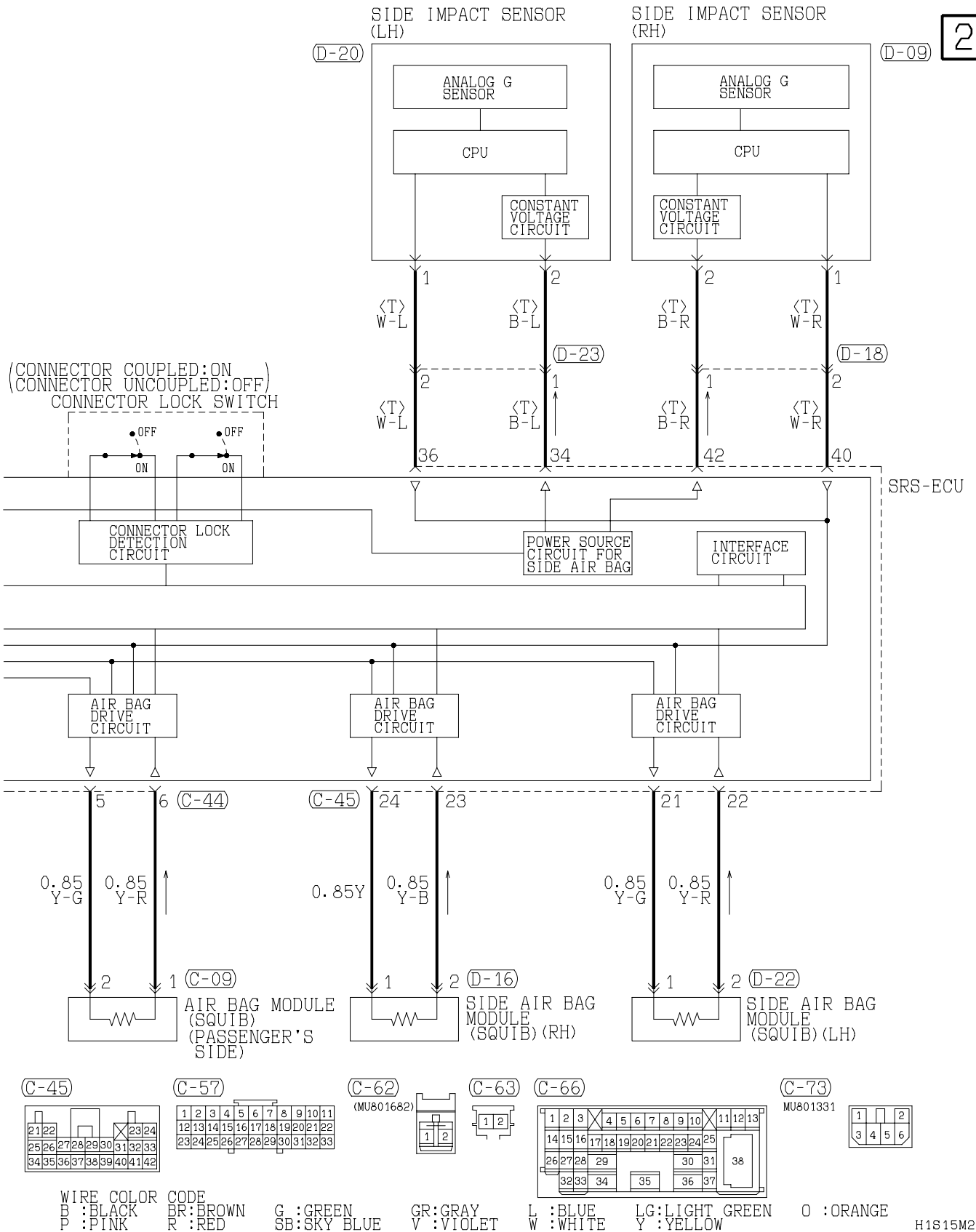

TSB Revision

POWER SEAT

1

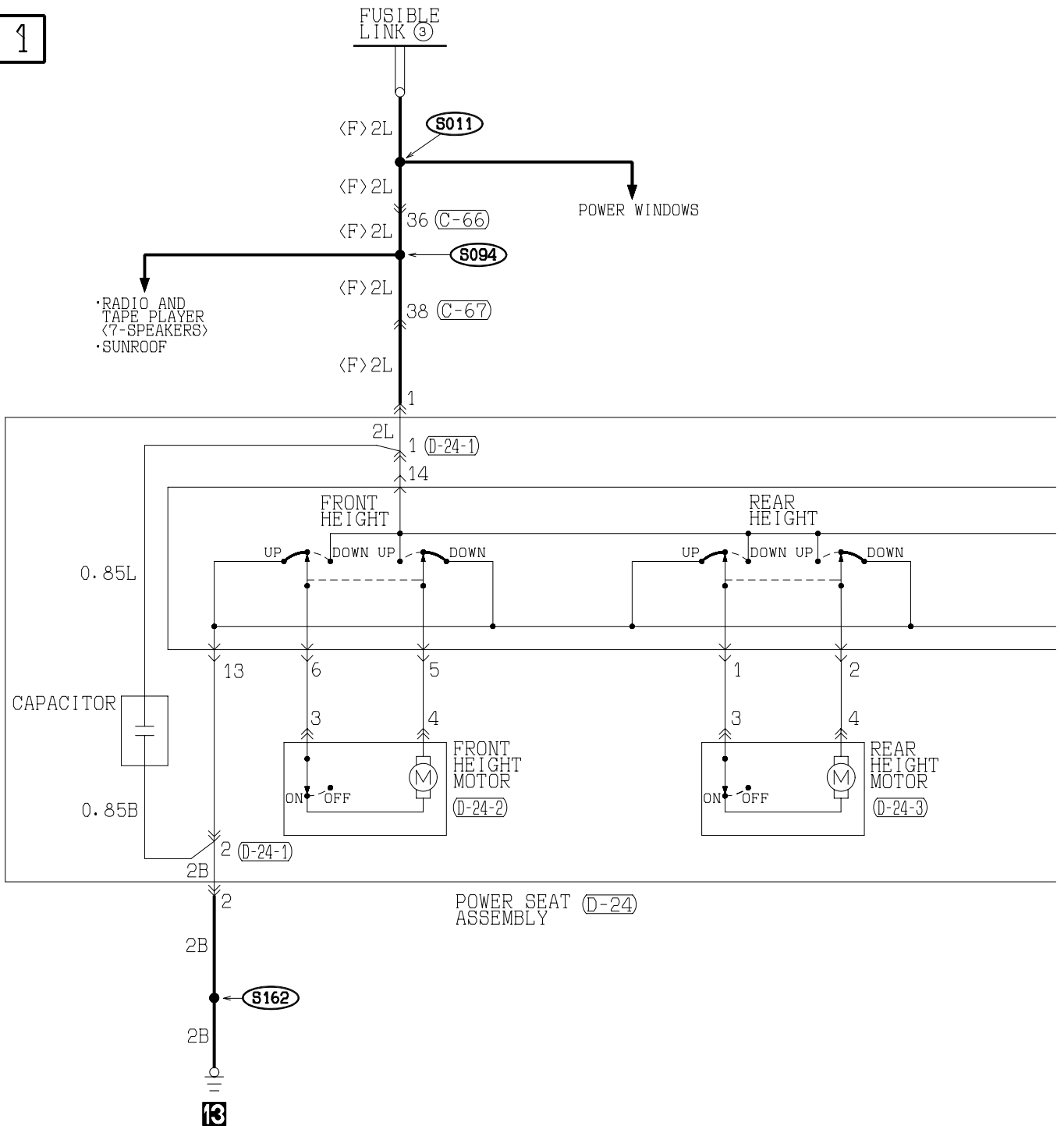

(C-66)

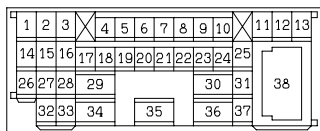

(C-67)

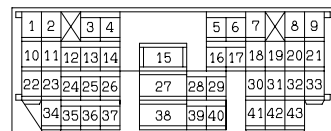

(D-24)



(D-24-1)



(D-24-2)



(D-24-3)



(D-24-4)



(D-24-5)



TSB Revision

2

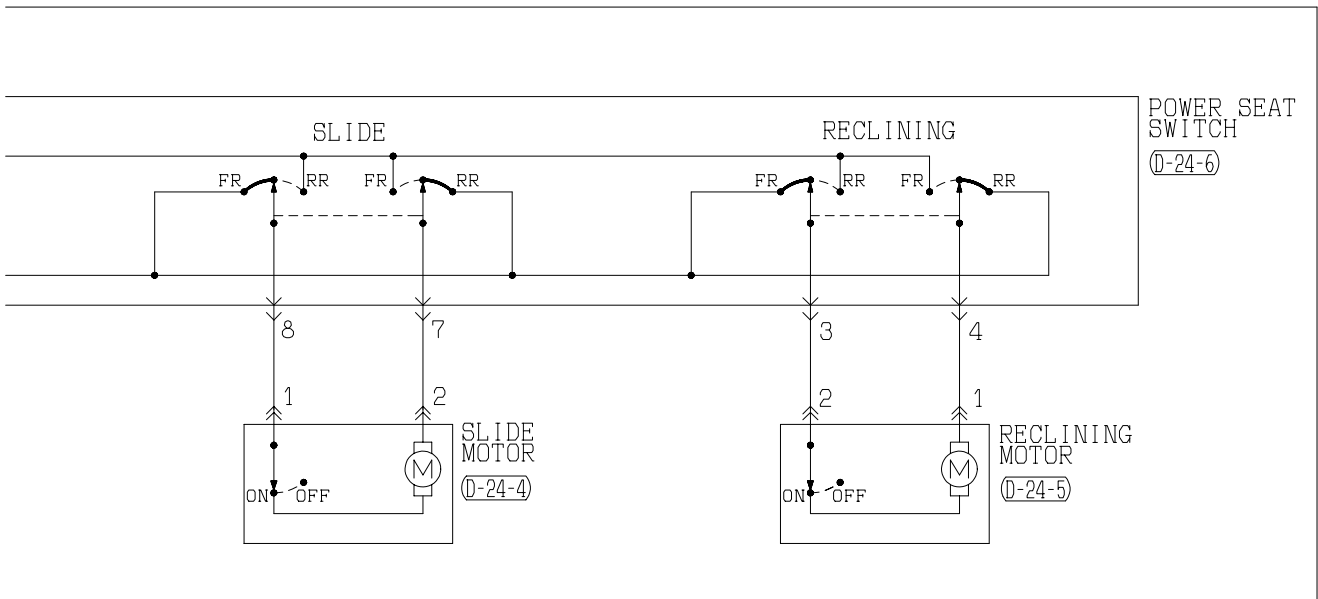

(D-24-6)

MU801453

1	2	3	4	5	6
7	8	9	10	11	12
13	14				

WIRE COLOR CODE
 B : BLACK BR : BROWN G : GREEN GR : GRAY L : BLUE LG : LIGHT GREEN O : ORANGE
 P : PINK R : RED SB : SKY BLUE V : VIOLET W : WHITE Y : YELLOW

H1S15M30AB

TSB Revision

THEFT-ALARM SYSTEM

1

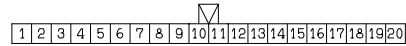
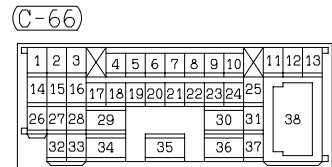
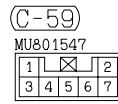
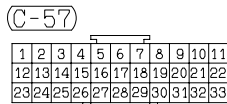
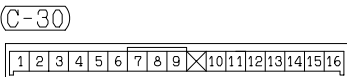
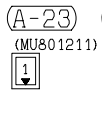
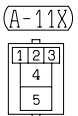
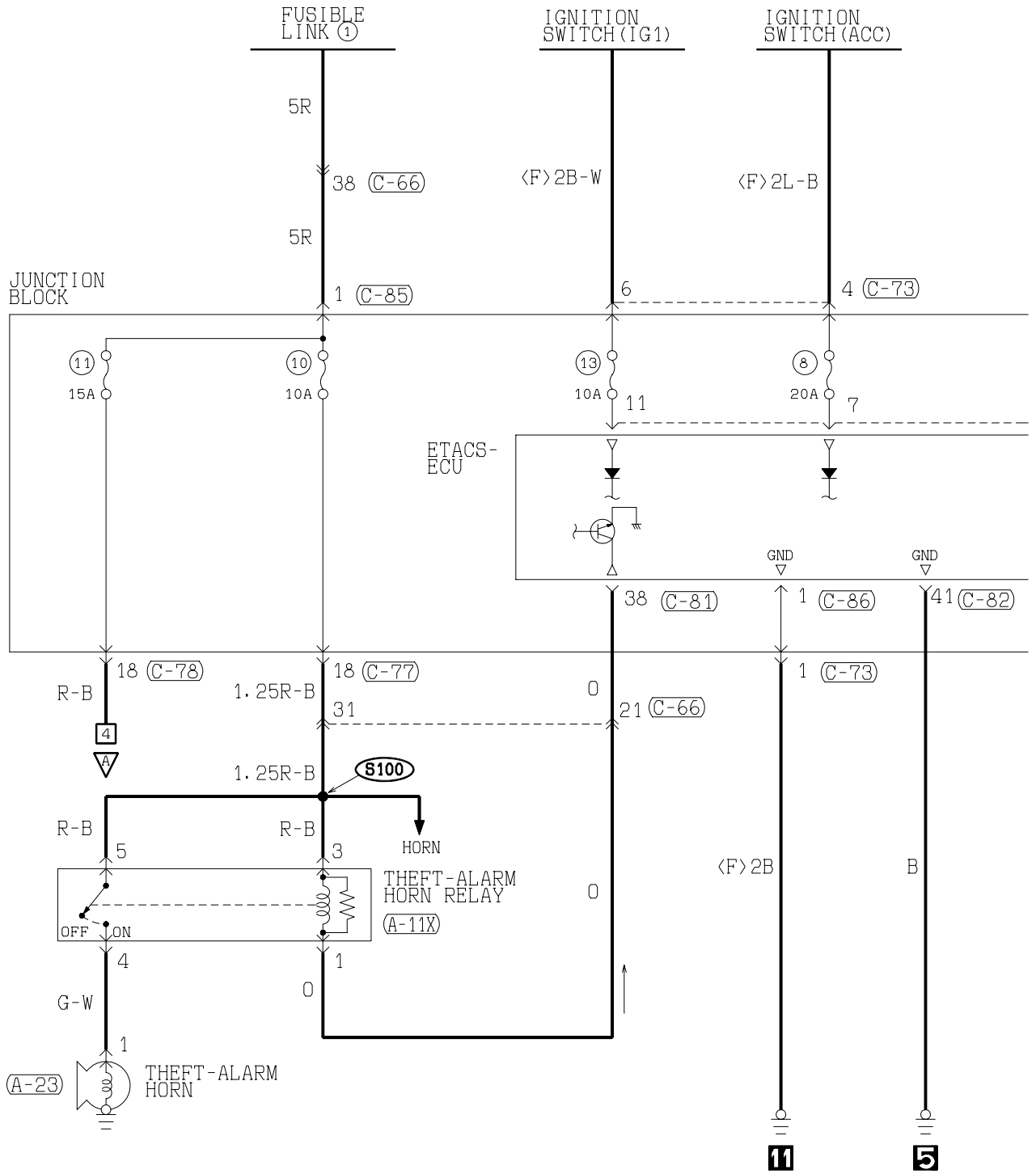

TSB Revision

2

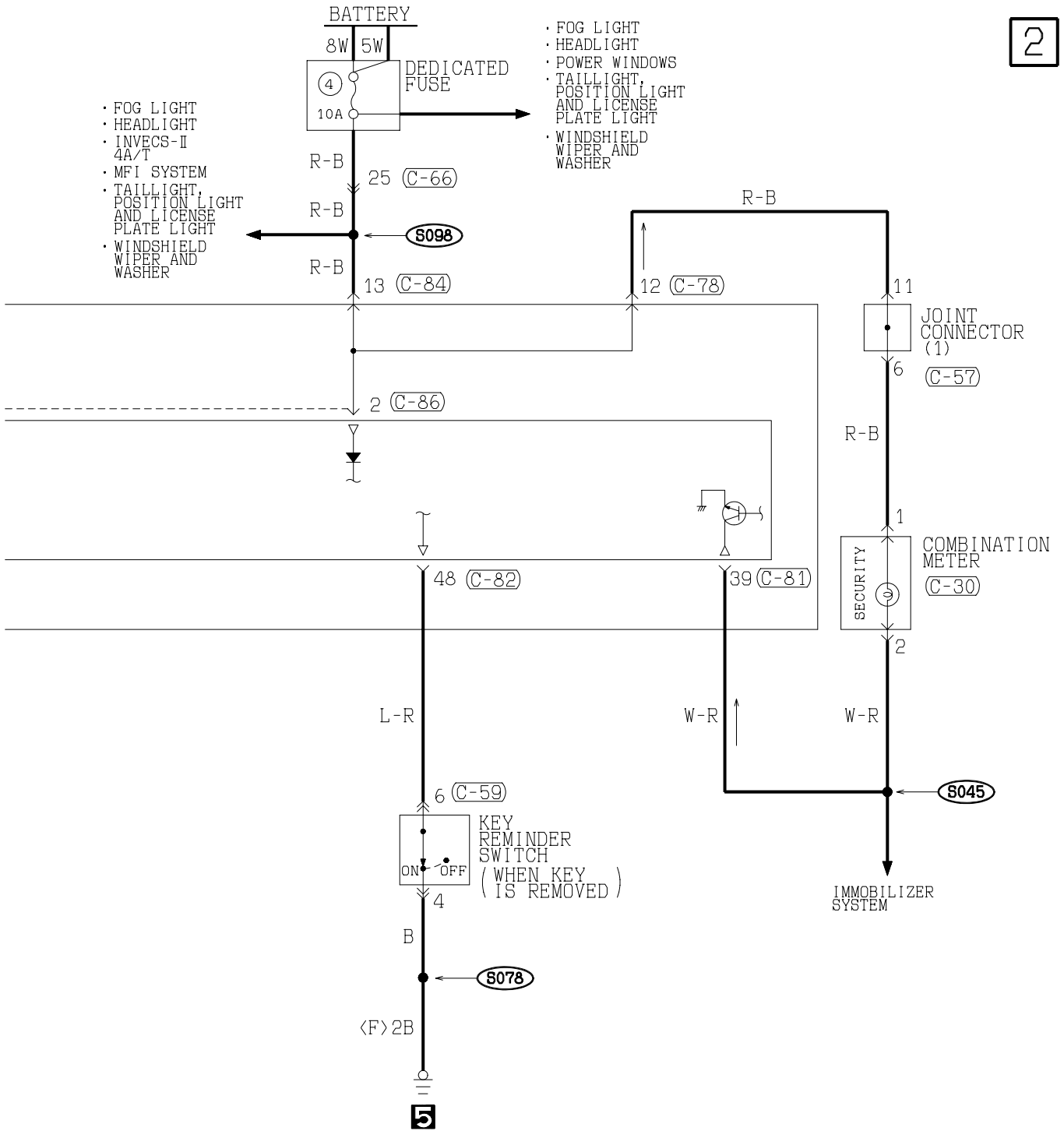

(C-73) MU801331



(C-77)

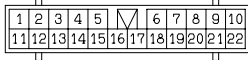

(C-78) MU801457

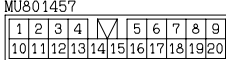

(C-81) (MU801585)



(C-82) (MU801584)

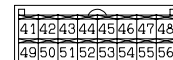

(C-84)

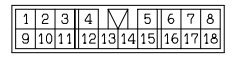

WIRE COLOR CODE

B : BLACK LG: LIGHT GREEN G : GREEN L : BLUE W : WHITE Y : YELLOW SB: SKY BLUE
BR: BROWN O : ORANGE GR: GRAY R : RED P : PINK V : VIOLET

H1S15M31AB

TSB Revision

THEFT-ALARM SYSTEM (CONTINUED)

3

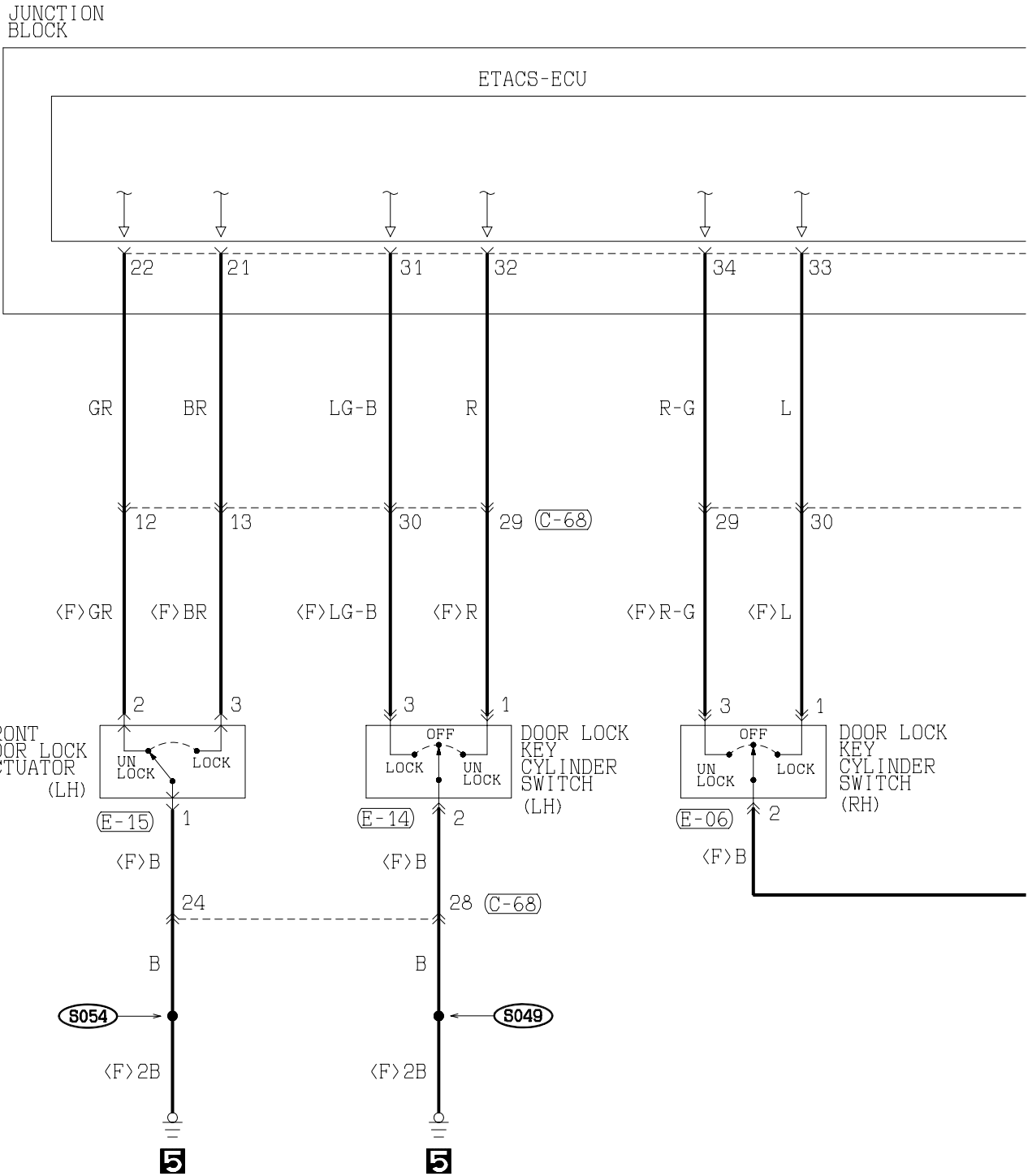

(C-23) FRONT SIDE

1	2	3	4	5	6	7	8
9	10	11	12	13	14	15	16

(C-68)

1	2	3	4	5	6	7	8	9
10	11	12	13	14	15	16	17	18
19	20	21	22	23	24	25	26	27
28	29	30	31	32				

(C-72)

1	2	3	4	5	6	7	8	9
10	11	12	13	14	15	16	17	18
19	20	21	22	23	24	25	26	27
28	29	30	31	32				

(C-81) (MU801585)

21	22	23	24	25	26	27	28	29	30
31	32	33	34	35	36	37	38	39	40

(C-82) (MU801584)

41	42	43	44	45	46	47	48
49	50	51	52	53	54	55	56



TSB Revision

4

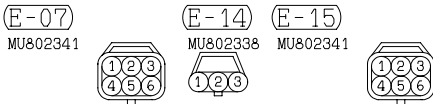
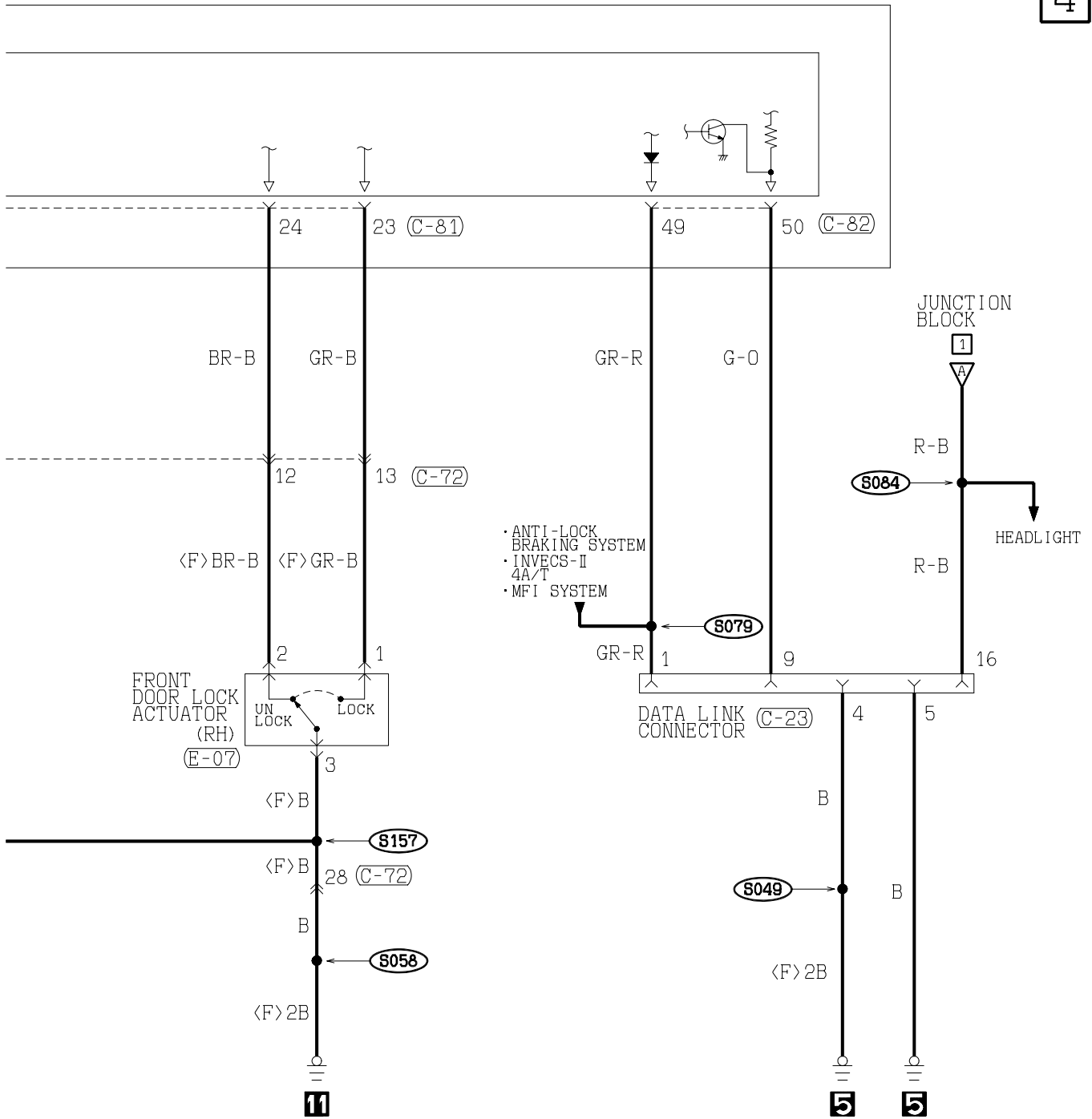

WIRE COLOR CODE
 B : BLACK BR : BROWN G : GREEN GR : GRAY L : BLUE LG : LIGHT GREEN O : ORANGE
 P : PINK R : RED SB : SKY BLUE V : VIOLET W : WHITE Y : YELLOW

H1S15M31BB

TSB Revision

THEFT-ALARM SYSTEM (CONTINUED)

5

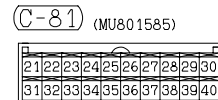
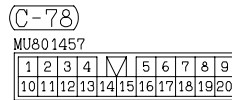
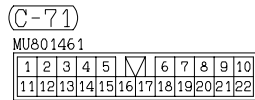
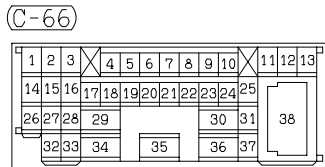
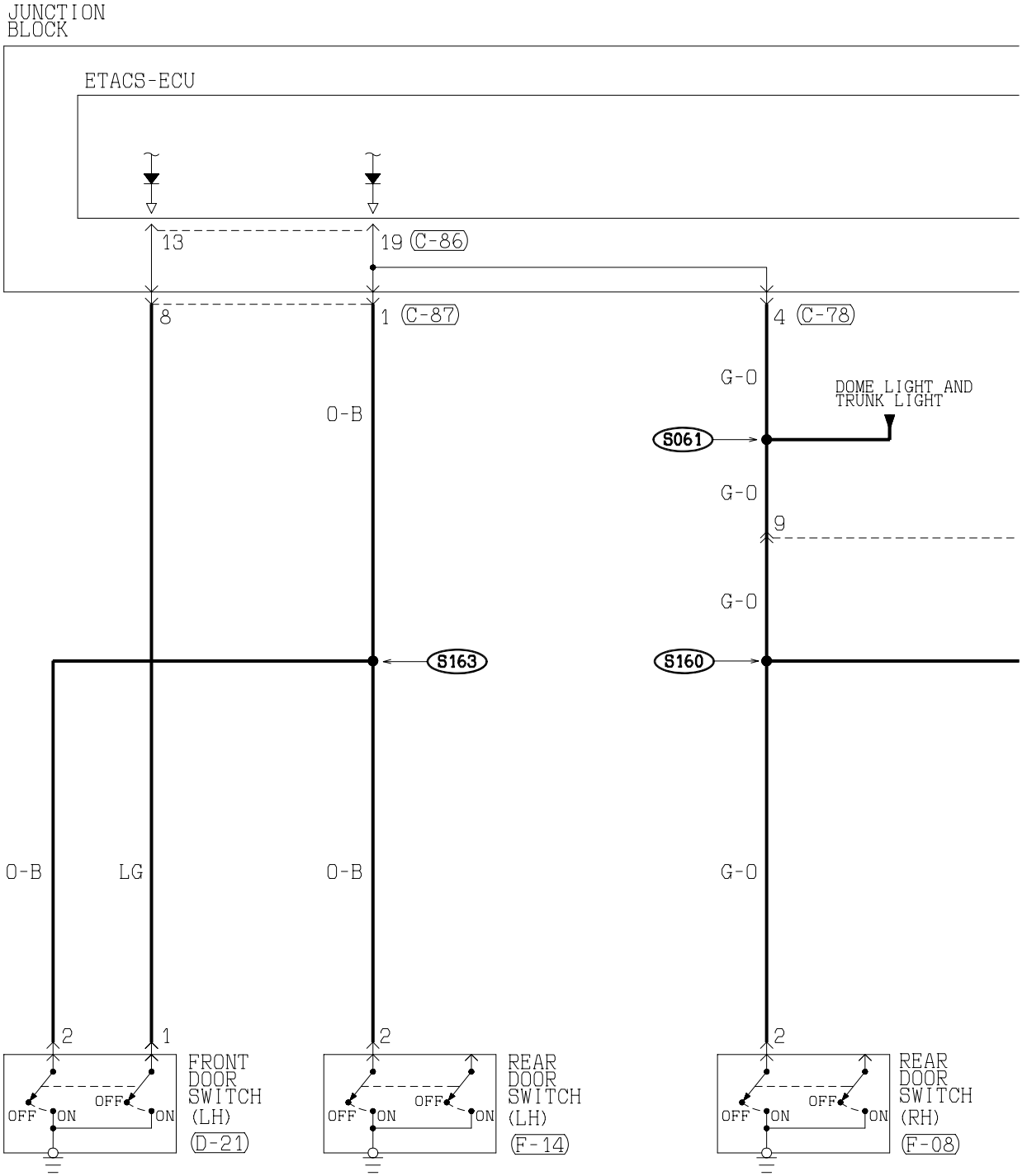

6

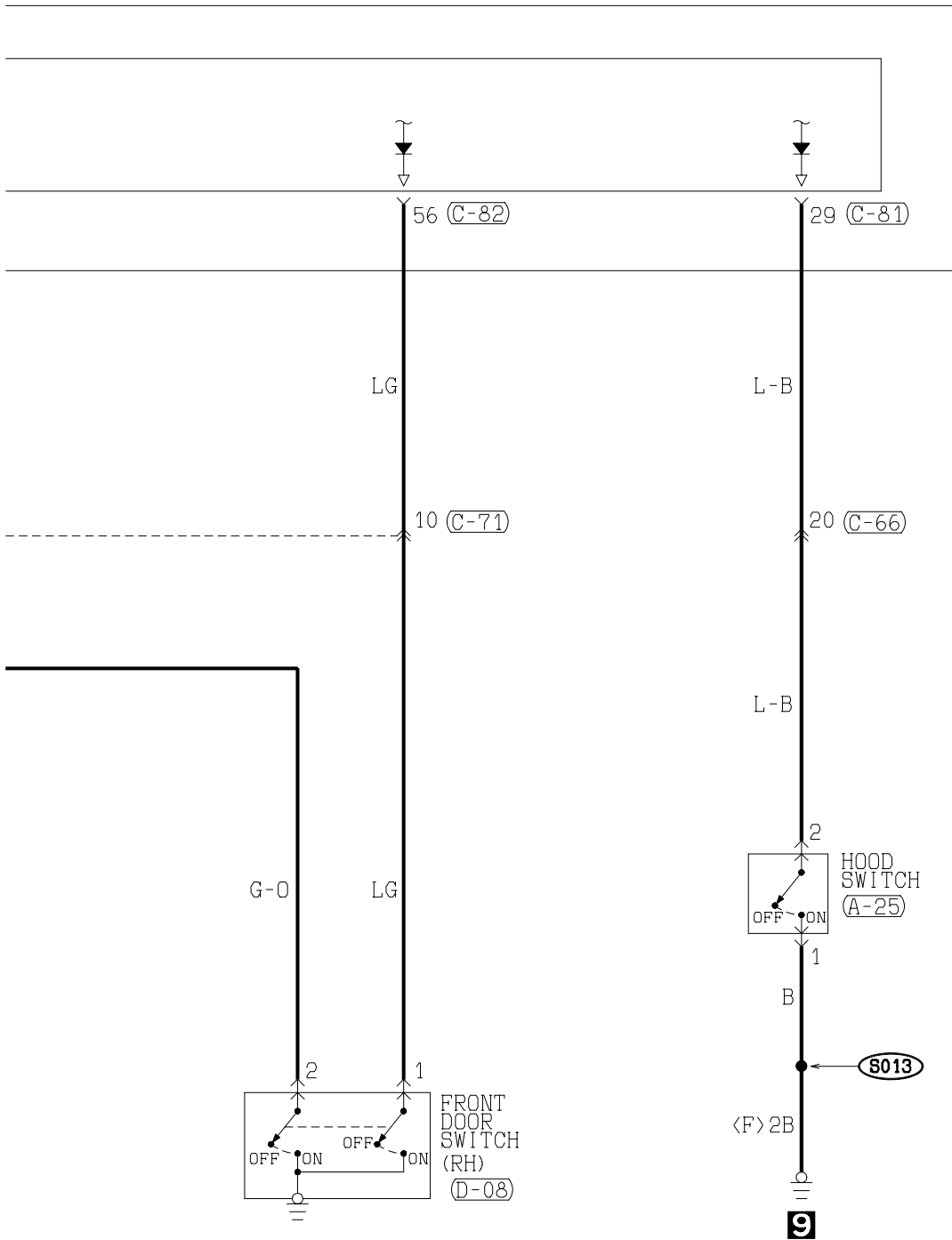

(C-82) (MU801584)

(C-86)

(C-87)

(D-08)

(D-21)

(F-08)

(F-14)

41	42	43	44	45	46	47	48
49	50	51	52	53	54	55	56

1	2	3	4	5	6	7	8	9	10	11	12	13	14	15	16	17	18	19	20
---	---	---	---	---	---	---	---	---	----	----	----	----	----	----	----	----	----	----	----

1	2	3	4	5	6	7	8	9	
10	11	12	13	14	15	16	17	18	19

1	2	3
---	---	---

1	2	3
---	---	---

1	2	3
---	---	---

1	2	3
---	---	---

WIRE COLOR CODE

B : BLACK BR: BROWN G : GREEN GR: GRAY L : BLUE LG: LIGHT GREEN O : ORANGE
P : PINK R : RED SB: SKY BLUE V : VIOLET W : WHITE Y : YELLOW

H1S15M31CB

TSB Revision

THEFT-ALARM SYSTEM (CONTINUED)

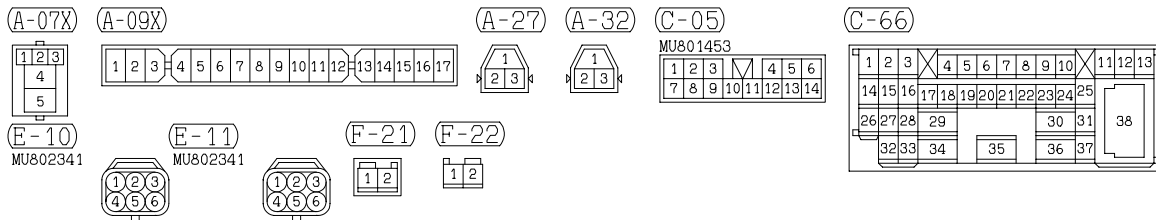
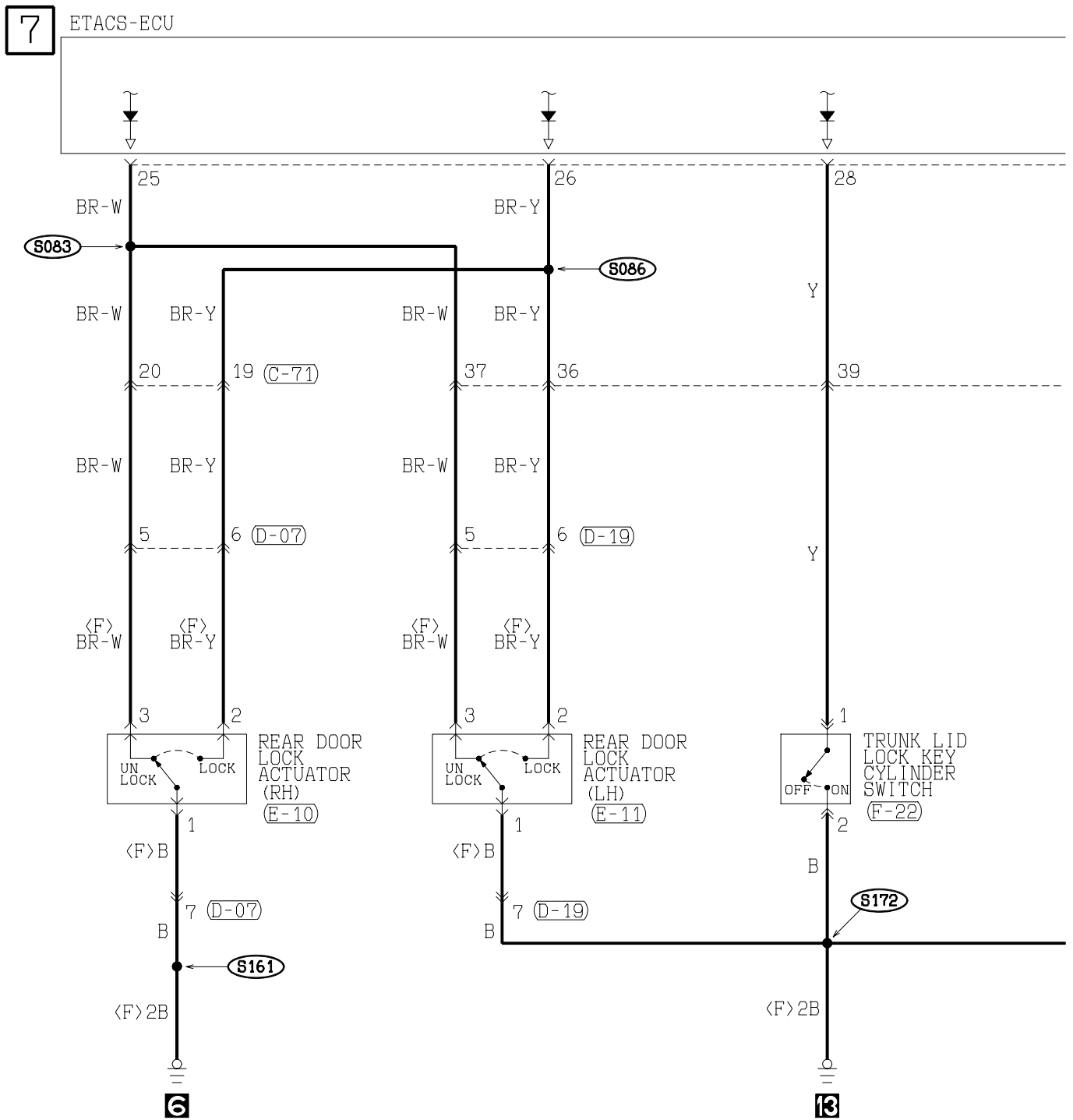

TSB Revision

FORGOTTEN KEY PREVENTION FUNCTION

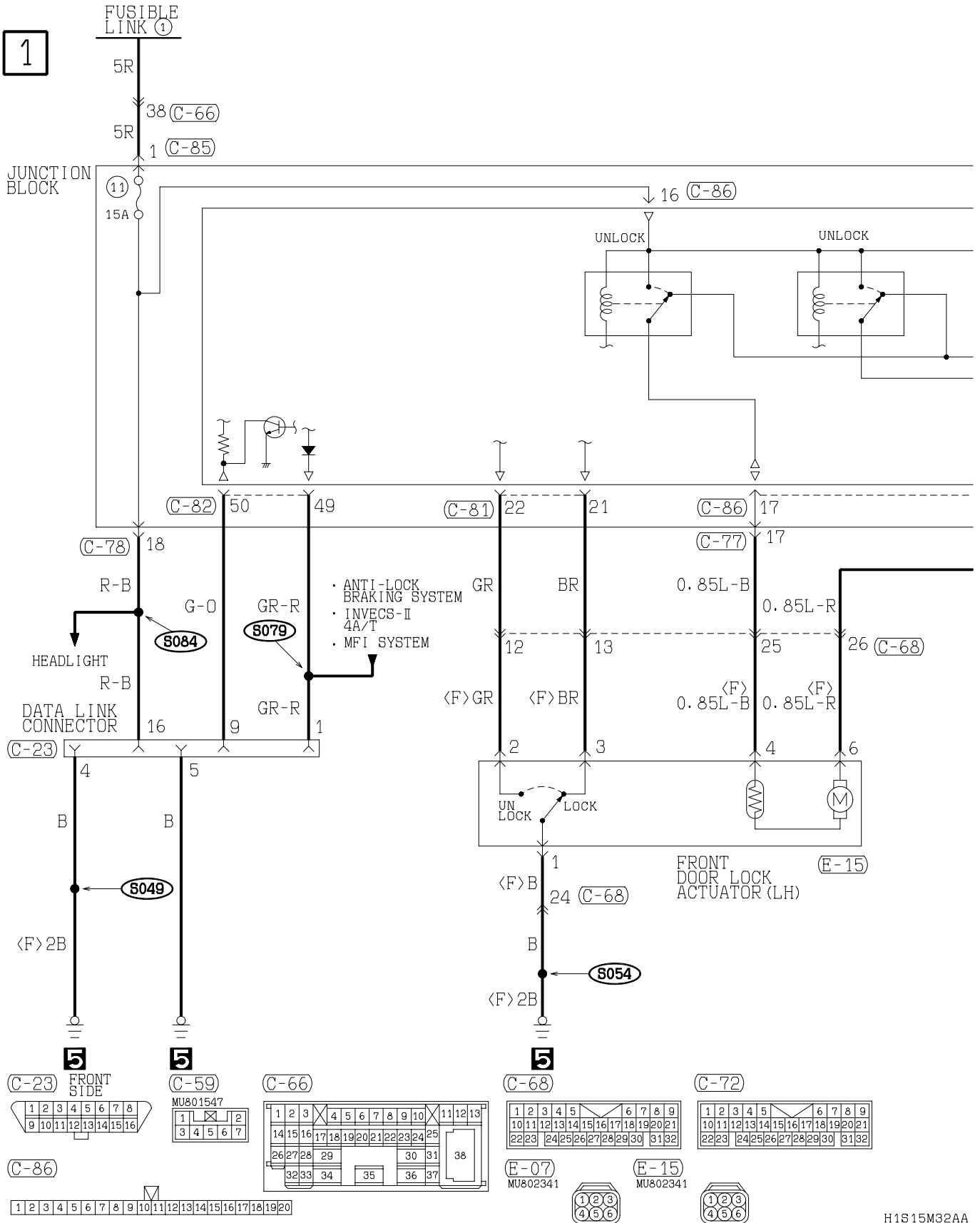

TSB Revision

2

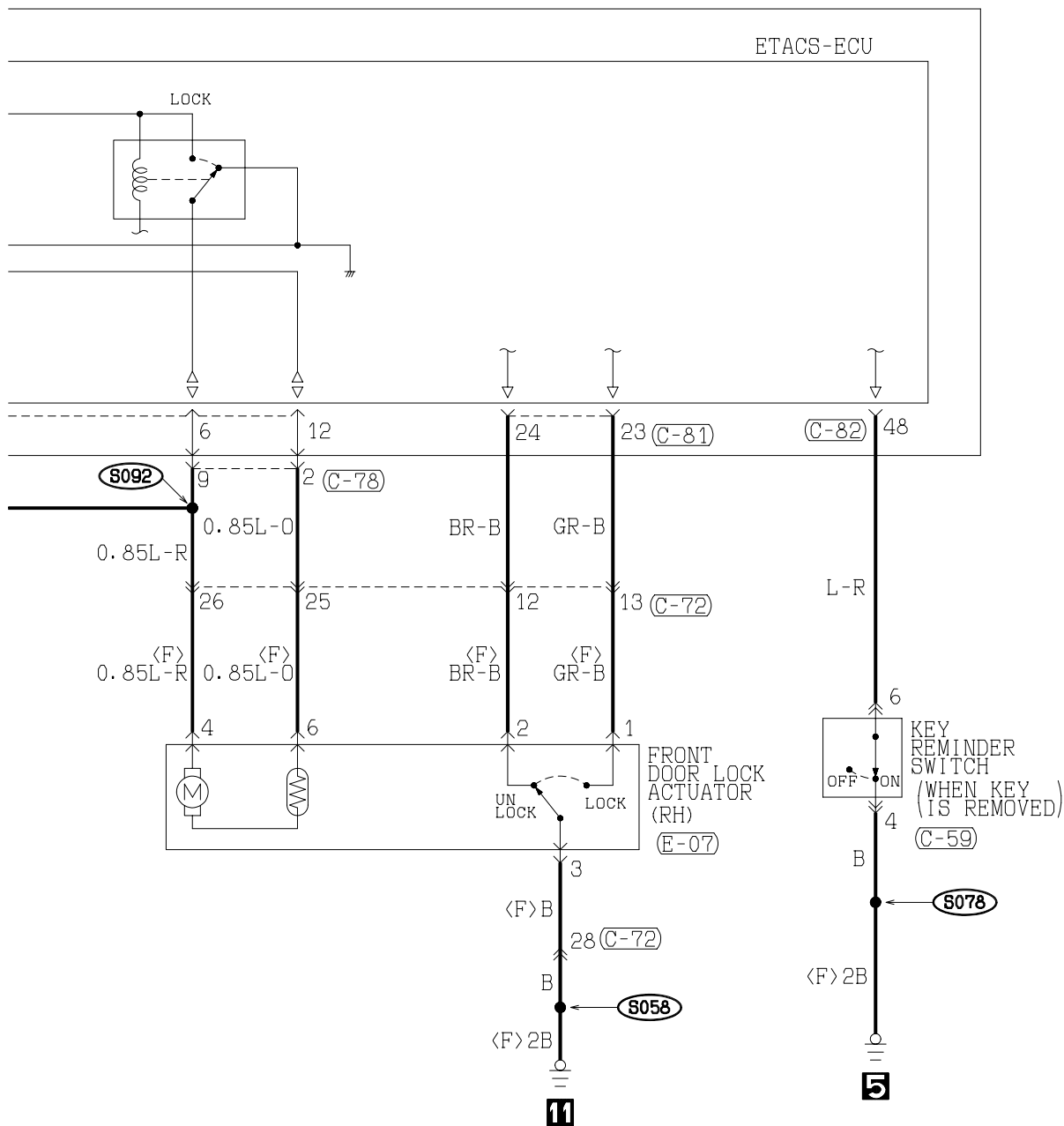

(C-77)

1	2	3	4	5	6	7	8	9	10
11	12	13	14	15	16	17	18	19	20
21	22	23	24	25	26	27	28	29	30
31	32	33	34	35	36	37	38	39	40

(C-78)

1	2	3	4	5	6	7	8	9
10	11	12	13	14	15	16	17	18
19	20							

(C-81) (MU801585)

21	22	23	24	25	26	27	28	29	30
31	32	33	34	35	36	37	38	39	40

(C-82) (MU801584)

41	42	43	44	45	46	47	48
49	50	51	52	53	54	55	56

(C-85)

1

WIRE COLOR CODE

B : BLACK BR : BROWN
P : PINK R : RED

G : GREEN SB : SKY BLUE

GR : GRAY V : VIOLET

L : BLUE W : WHITE

LG : LIGHT GREEN Y : YELLOW

O : ORANGE

FORGOTTEN KEY PREVENTION FUNCTION (CONTINUED)

3

JUNCTION BLOCK

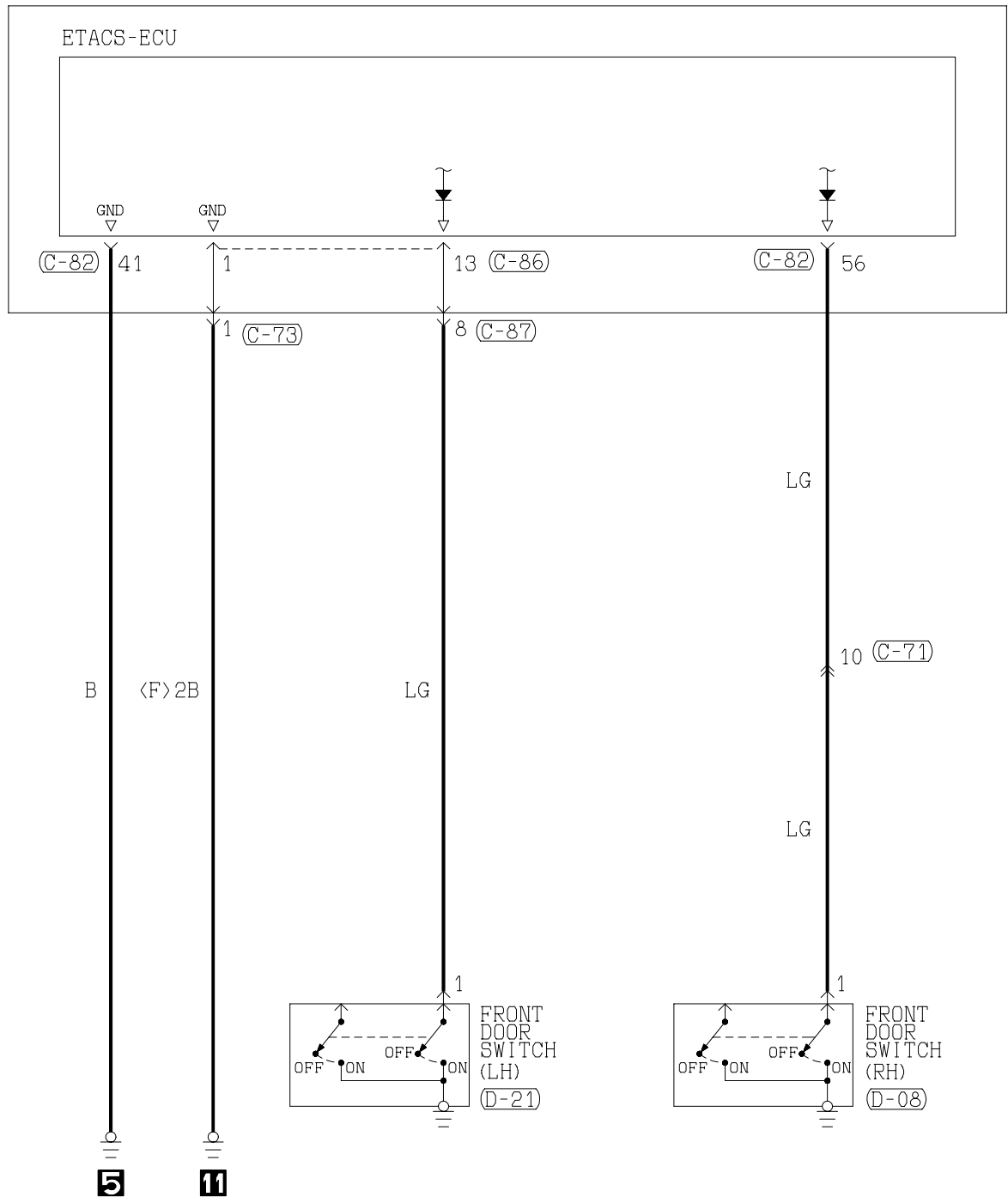

(C-71)

MU801461

1	2	3	4	5	M	6	7	8	9	10	
11	12	13	14	15	16	17	18	19	20	21	22

(C-73)

MU801331

1	2
3	4
5	6

(C-82) (MU801584)

41	42	43	44	45	46	47	48
49	50	51	52	53	54	55	56

(C-86)

1	2	3	4	5	6	7	8	9	10	M	12	13	14	15	16	17	18	19	20
---	---	---	---	---	---	---	---	---	----	---	----	----	----	----	----	----	----	----	----

(C-87)

1	2	3	4	M	5	6	7	8	9
10	11	12	13	14	15	16	17	18	19

(D-08)

1	2	3
---	---	---

(D-21)

1	2	3
---	---	---

WIRE COLOR CODE
 B : BLACK BR: BROWN G : GREEN GR: GRAY L : BLUE LG: LIGHT GREEN O : ORANGE
 P : PINK R : RED SB: SKY BLUE V : VIOLET W : WHITE Y : YELLOW

H1S15M32BA

TSB Revision

RHEOSTAT

1

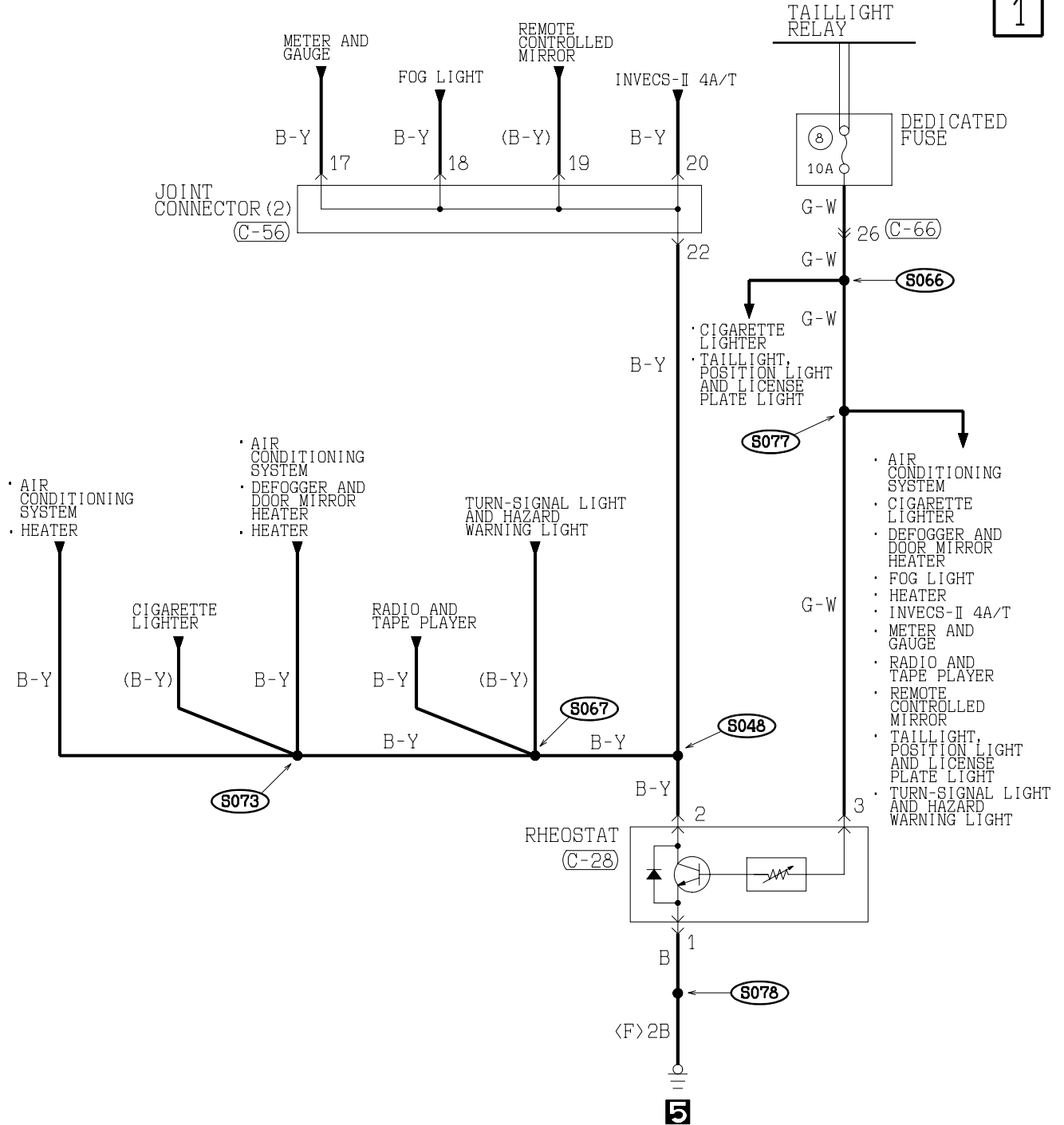

(C-28)

MU801443	1	2	3
1	2	3	

(C-56)

1	2	3	4	5	6	7	8	9	10	11
12	13	14	15	16	17	18	19	20	21	22
23	24	25	26	27	28	29	30	31	32	33

(C-66)

1	2	3	4	5	6	7	8	9	10	11	12	13
14	15	16	17	18	19	20	21	22	23	24	25	
26	27	28	29					30	31		38	
32	33	34		35		36	37					

WIRE COLOR CODE
B : BLACK BR : BROWN
P : PINK R : RED

G : GREEN GR : GRAY L : BLUE
SB : SKY BLUE V : VIOLET W : WHITE

LG : LIGHT GREEN O : ORANGE
Y : YELLOW

H1S15M33AA

TSB Revision

IMMOBILIZER SYSTEM

1

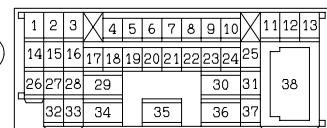
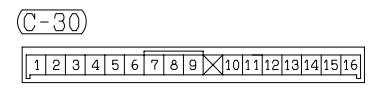
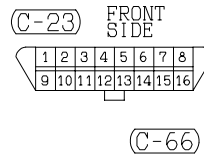
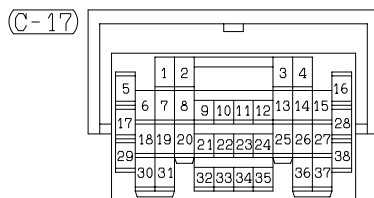
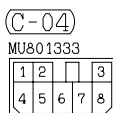
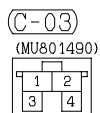
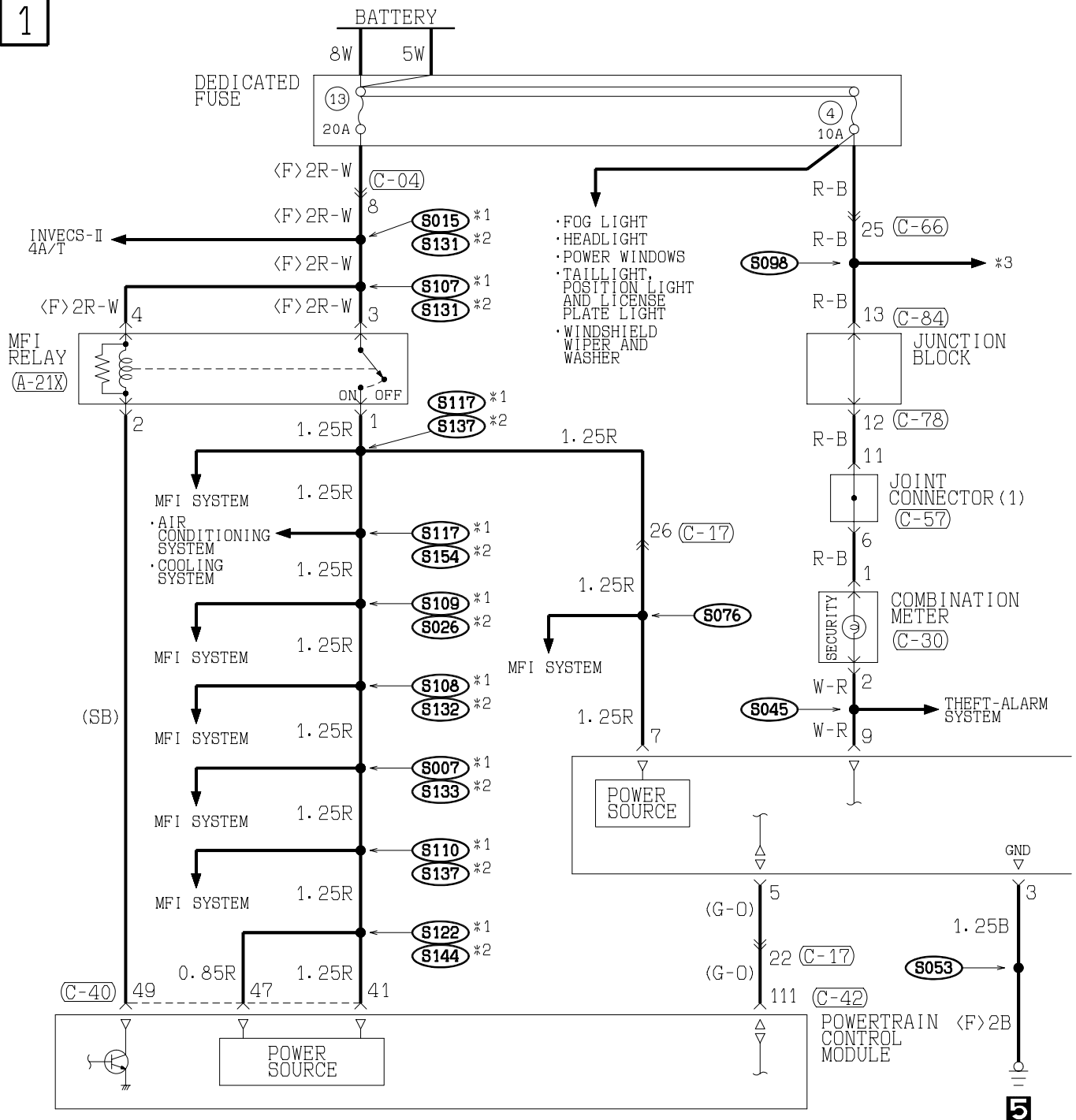

H1S15M34AA

TSB Revision

2

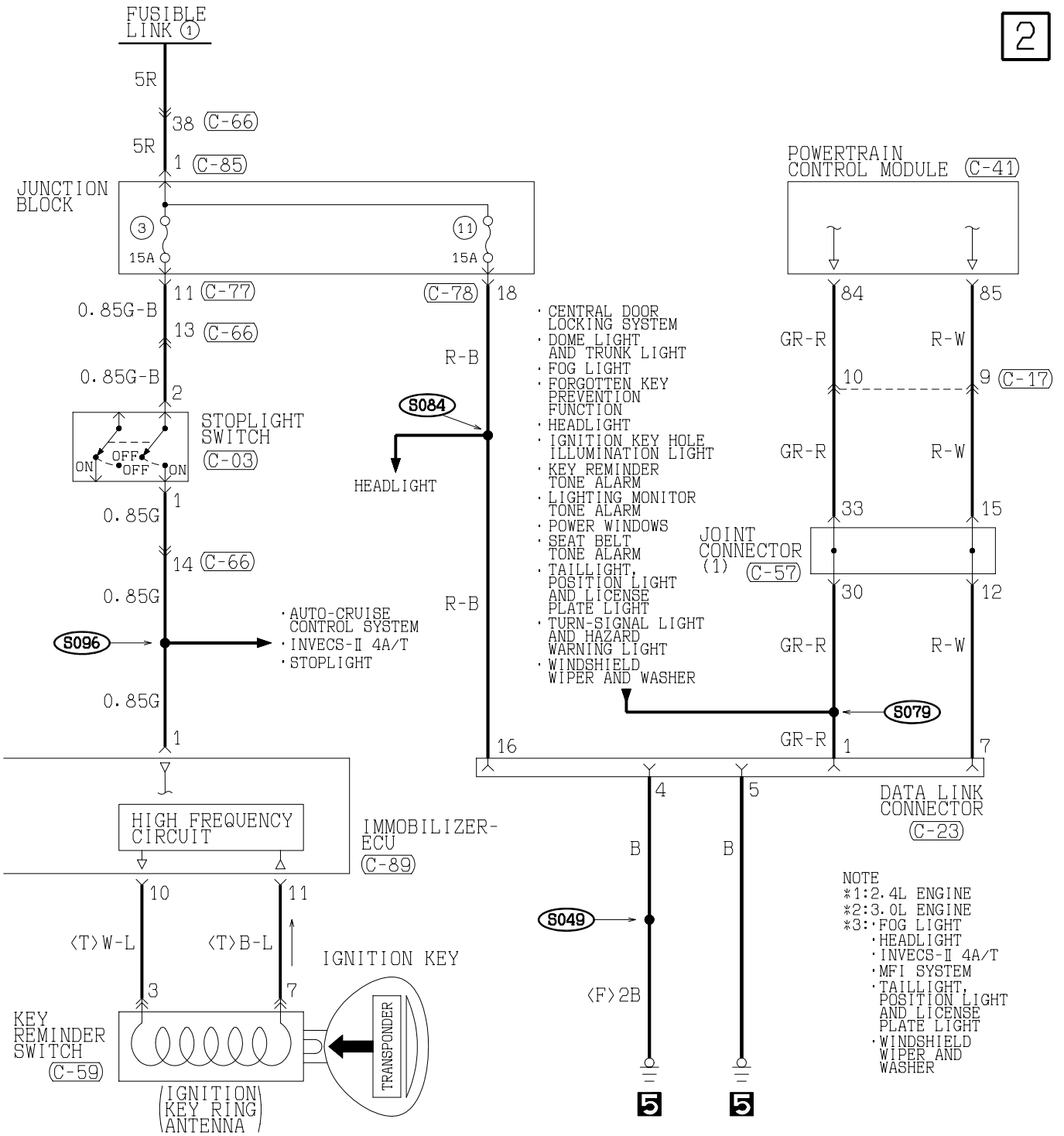

- CENTRAL DOOR LOCKING SYSTEM
- DOME LIGHT AND TRUNK LIGHT
- FOG LIGHT
- FORGOTTEN KEY PREVENTION FUNCTION
- HEADLIGHT
- IGNITION KEY HOLE ILLUMINATION LIGHT
- KEY REMINDER TONE ALARM
- LIGHTING MONITOR TONE ALARM
- POWER WINDOWS
- SEAT BELT TONE ALARM
- TAILLIGHT, POSITION LIGHT AND LICENSE PLATE LIGHT
- TURN-SIGNAL LIGHT AND HAZARD WARNING LIGHT
- WINDSHIELD WIPER AND WASHER

NOTE
 *1: 2.4L ENGINE
 *2: 3.0L ENGINE
 *3: FOG LIGHT
 • HEADLIGHT
 • INVECS-II 4A/T
 • MFI SYSTEM
 • TAILLIGHT, POSITION LIGHT AND LICENSE PLATE LIGHT
 • WINDSHIELD WIPER AND WASHER

(C-40) (MU803781)

41	42	43		44	45	46
47	48	49	50	51	52	53
54	55	56	57	58	59	60
61	62	63	64	65	66	

(C-41) (MU803782)

71	72	73	74		75	76	77
78	79	80	81	82	83	84	85
86	87	88	89	90	91	92	93
94	95	96	97	98			

(C-42) (MU803783)

101	102	103	104		105	106	107
108	109	110	111	112	113	114	115
116	117	118	119	120	121	122	123
124	125	126	127	128	129	130	

(C-57)

1	2	3	4	5	6	7	8	9	10	11
12	13	14	15	16	17	18	19	20	21	22
23	24	25	26	27	28	29	30	31	32	33

(C-59) MU801547

1	2	3	4	5	6	7
8	9	10	11	12	13	14

(C-77)

1	2	3	4	5	M	6	7	8	9	10
11	12	13	14	15	16	17	18	19	20	21
22										

(C-78) MU801457

1	2	3	4	M	5	6	7	8	9
10	11	12	13	14	15	16	17	18	19
20									

(C-84)

1	2	3	4	M	5	6	7	8
9	10	11	12	13	14	15	16	17
18								

(C-85)

1

(C-89) (MU801468)

1	2	3	4	5
6	7	8	9	10
11	12			

TSB Revision

NOTES