

Service Manual

MONTERO

1989 : Volume 2

FOREWORD

This Service Manual has been prepared with the latest service information available at the time of publication. It is subdivided into various group categories and each section contains diagnosis, disassembly, repair, and installation procedures along with complete specifications and tightening references. Use of this manual will aid in properly performing any servicing necessary to maintain or restore the high levels of performance and reliability designed into these outstanding vehicles.



Mitsubishi Motors corporation reserves the right to make changes in design or to make additions to or improvements in its products without imposing any obligations upon itself to install them on its products previously manufactured.

GROUP/SECTION INDEX N00AA-B

Introduction	
Electrical	8
Electrical System Parts	
Location	
Relays, Control Units, Sensors, Fuses, Groundings	
Inspection of Harness	
Connector	
Wiring Harness	
Charging System	
Starting System	
Ignition System	
Meters and Gauges	
Lighting System	
Wiper and Washer System	
Horn	
Accessory	
Audio System	
Back Door Window Defogger	
Automatic Free-wheeling Hub	
Indicator System	

NOTE
For Engine, Chassis & Body, refer to
... Volume-1
"Engine, Chassis & Body"

HOW TO USE THIS MANUAL

NO0BAAR

CONTENTS

The preceding page contains the GROUP INDEX which lists the group title and group number.

PAGE NUMBERS

All page numbers consist of two sets of digits separated by a dash. The digits preceding the dash identify the number of the group. The digits following the dash represent the consecutive page number within the group. The page numbers can be found on the top left or right of each page.

TEXT

Unless otherwise specified, each service procedure covers all models. Procedures covering specific models are identified by the model codes, or similar designation (engine type, transmission type, etc.). A description of these designations is covered in this unit under "VEHICLE IDENTIFICATION".

TROUBLESHOOTING

Troubleshootings are classified into master troubleshooting and group troubleshooting and located as follows:

The master troubleshooting is prepared when the trouble symptom relates to two or more groups and given in MASTER TROUBLESHOOTING.

The group troubleshooting guide is prepared for causes of problems related to that individual group only; a troubleshooting guide is prepared for each appropriate group.

SERVICE PROCEDURES

The service steps are arranged in numerical order and attentions to be paid in performing vehicle service are described in detail in SERVICE POINTS.

DEFINITION OF TERMS

STANDARD VALUE

Indicates the value used as the standard for judging the quality of a part or assembly on inspection or the value to which the part or assembly is corrected and adjusted. It is given by tolerance.

LIMIT

Shows the standard for judging the quality of a part or assembly on inspection and means the maximum or minimum value within which the part or assembly must be kept functionally or in strength. It is a value established outside the range of standard value.

Indicates incidental operation to be performed before removal or after installation

Removal steps : The numbers before part names correspond to numbers in the illustration and indicate the order of removal.

Disassembly steps : The numbers before part names correspond to numbers in the illustration, and indicate the order of disassembly.

Installation steps : This is provided if installation cannot be made in the reverse order of "Removal steps"; omitted if installation in the reverse order of "Removal steps" is possible.

Reassembly steps : This is provided if reassembly cannot be made in the reverse order of "Disassembly steps"; omitted if reassembly in the reverse order of "Disassembly steps" is possible.

Classification of SERVICE POINTS

◀▶ : Removal
 ▶▶ : Installation
 ▶▶ : Disassembly
 ▶▶ : Reassembly

MODEL INDICATIONS

The following abbreviations are used in this manual for classification of model types.

M/T : Indicates the manual transmission, or models equipped with the manual transmission.
 A/T : Indicates the automatic transmission, or models equipped with the automatic transmission.
 F.B.C. : Indicates the feed back carburetor, or engines equipped with the feed back carburetor.
 M.P.I. : Indicates the multi-point injection, or engines equipped with the multi-point injection.
 2.6 L Engine : Indicates the 2.6 liters (155.9 cu.in.) engine, or a model equipped with such an engine.
 3.0 L Engine : Indicates the 3.0 liters (181.4 cu.in.) engine, or a model equipped with such an engine.

Page number

Group title

Section title

7-10

COOLING - Thermostat

**THERMOSTAT
REMOVAL AND INSTALLATION**

- Pre-removal Operation**
- Draining of the Coolant (Refer to GROUP 0 LUBRICATION AND MAINTENANCE - Maintenance Service.)
- Post-installation Operation**
- Supplying of the Coolant (Refer to GROUP 0 LUBRICATION AND MAINTENANCE - Maintenance Service.)

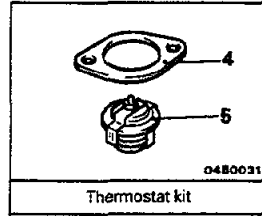
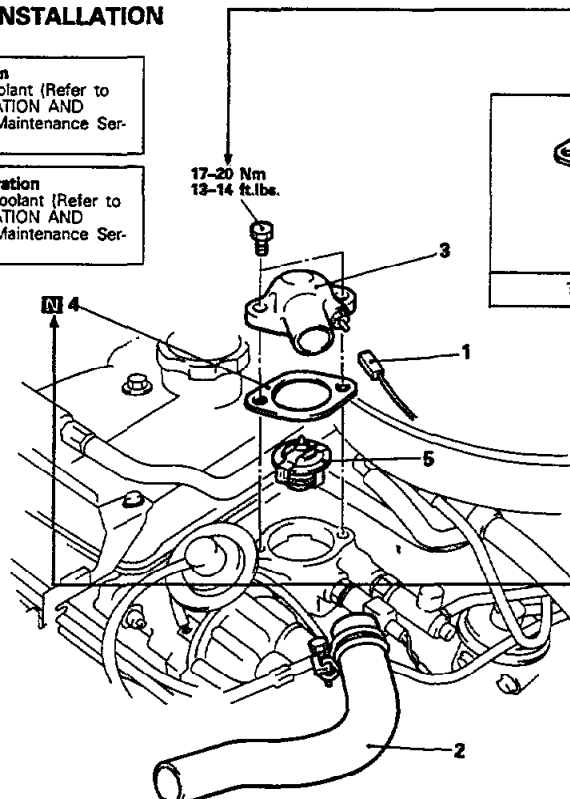

Indicates tightening torque

Repair kit or set parts are shown. (Only very frequently used parts are shown.)

Indicates non-reusable part.

This number corresponds to the number in "Removal steps", "Disassembly steps", "Installation steps" or "Reassembly steps".

- Removal steps**
1. Connection of engine coolant temperature switch connector (Vehicles with an air conditioner)
 2. Connection of radiator upper hose
 3. Water outlet fitting
 4. Water outlet fitting gasket
 5. Thermostat

NOTE
 (1) Reverse the removal procedures to reinstall.
 (2) ●●● : Refer to "Service Points of Installation"
 (3) [N] : Non-reusable parts

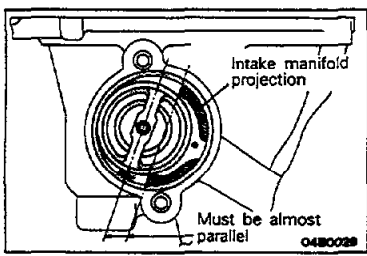

SERVICE POINTS OF INSTALLATION

5. **INSTALLATION OF THERMOSTAT**
 Install the thermostat to the intake manifold as illustrated.

Caution
 The thermostat flange fits over the manifold seat; ensure that the thermostat is not installed at an angle.

An explanation of procedures, notes, etc. regarding removal, installation, disassembly and reassembly.

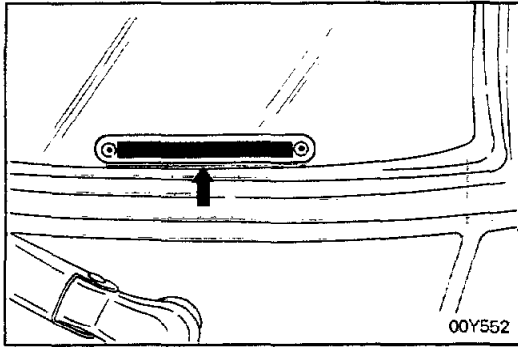

VEHICLE IDENTIFICATION

VEHICLE IDENTIFICATION NUMBER LOCATION

N00CA--

The vehicle identification number (V.I.N.) is located on a plate attached to the left top side of the instrument panel.

VEHICLE IDENTIFICATION CODE CHART PLATE

N00CB--

All vehicle identification numbers contain 17 digits. The vehicle number is a code which tells country, make, vehicle type, etc.

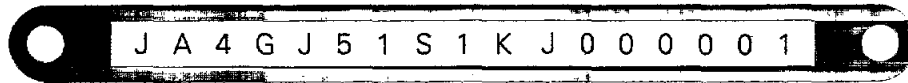

1st digit	2nd digit	3rd digit	4th digit	5th digit	6th digit	7th digit	8th digit	9th digit	10th digit	11th digit	12th thru 17th digit
Country	Make	Vehicle type	Others	Line	Price class	Body	Engine	Check digit	Model year	Plant	Serial number
J- Japan	A- Mitsu-bishi	4- Multi-purpose vehicle (MPV) 7- Truck	F- 4001-5000 lbs. and with hydraulic brakes G- 5001-6000 lbs. and with hydraulic brakes	J- MON-TERO	4- High 5- Pre-mium	1- 5-door wagon 3- 3-door metal-top or van	E- 2.6 liters (155.9 cu.in.) S- 3.0 liters (181.4 cu.in.)	0 1 2 3 . . 9 X	K- 1989 year	J- Nagoya -3	000001 to 999999

NOTE
 ***Check digit** means a single number or letter X used to verify the accuracy of transcription of vehicle identification number.

VEHICLE IDENTIFICATION NUMBER LIST

FEDERAL

N00CC-

VIN (except sequence number)	Brand	Engine displacement	Model code
JA7FJ43E □ KJ	MITSUBISHI MONTERO	2.555 liters (155.9 cu.in.)	L042GTNJLF
JA7FJ43S □ KJ JA7FJ43S □ KJ JA7FJ53S □ KJ JA4GJ41S □ KJ JA4GJ41S □ KJ JA4GJ51S □ KJ		2.972 liters (181.4 cu.in.)	L141GTNJLF L141GTRJLF L141GTRULF L146GVMNJLF L146GVMRJLF L146GWMRULF

CALIFORNIA (Can also be sold in Federal states.)

VIN (except sequence number)	Brand	Engine displacement	Model code
JA7FJ43E □ KJ	MITSUBISHI MONTERO	2.555 liters (155.9 cu.in.)	L042GTNJLH
JA7FJ43S □ KJ JA7FJ43S □ KJ JA7FJ53S □ KJ JA4GJ41S □ KJ JA4GJ41S □ KJ JA4GJ51S □ KJ		2.972 liters (181.4 cu.in.)	L141GTNJLH L141GTRJLH L141GTRULH L146GVMNJLH L146GVMRJLH L146GWMRULH

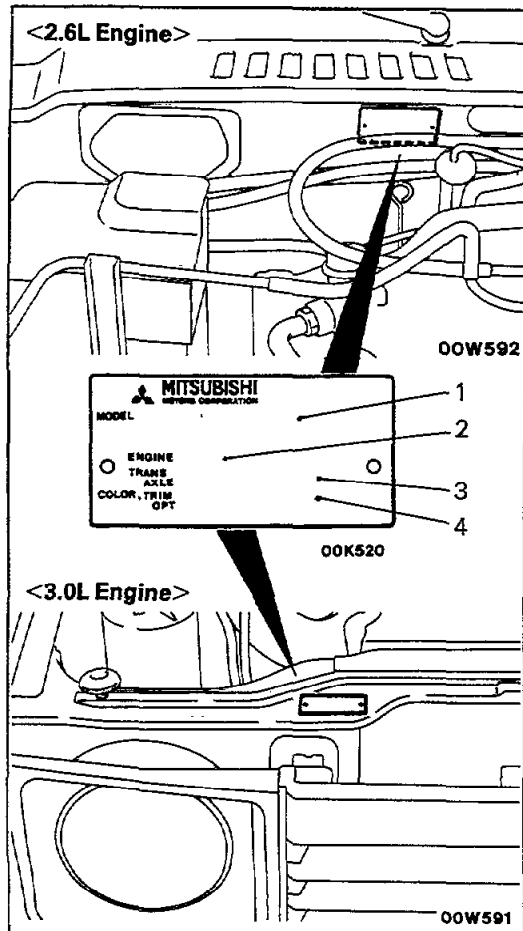

VEHICLE INFORMATION CODE PLATE

N00CD-

Vehicle information code plate is riveted on the cowl top outer panel (2.6L Engine) or front end upper bar (3.0L Engine) in the engine compartment.

The plate shows model code, engine model, transmission model, and body color code.

- 1. MODEL **L146G VMNJLF**
 - Model series
 - Vehicle model
 - 2. ENGINE **6G72**
 - Engine model
 - 3. TRANS AXLE **V5MT1**
 - Transmission model
 - 4. COLOR, TRIM OPT **H84**
 - Monotone exterior color code
 - H1XH84X85**
 - Two-tone color code
 - Exterior code
- Two-tone exterior is shown by the exterior code followed by the two color codes.

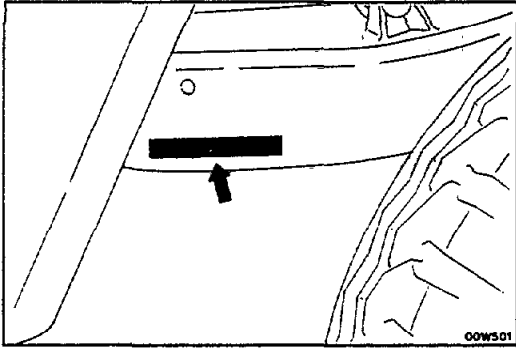

CHASSIS NUMBER STAMPING LOCATION

N00CE-

The chassis number is stamped on the side of the frame near the right rear wheel.

CHASSIS NUMBER CODE CHART

L141 V KJ000001

Vehicle line	Body type	Refer to 10th thru 17th digits of V.I.N. plate
L042, L141 or L146-MONTERO	V-metal-top	

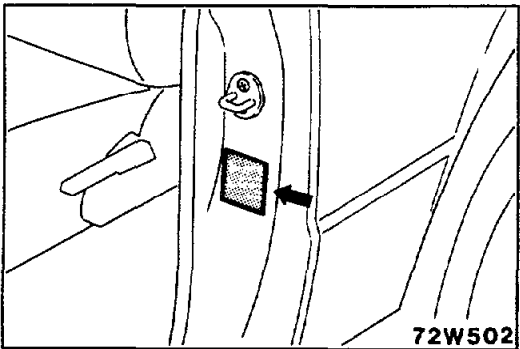

VEHICLE SAFETY CERTIFICATION LABEL

N00CF-

The vehicle safety certification label is attached to face of left door pillar.

This label indicates the month and year of manufacture, Gross Vehicle Weight Rating (G.V.W.R.), front and rear Gross Axle Weight Rating (G.A.W.R.), and Vehicle Identification Number (V.I.N.).

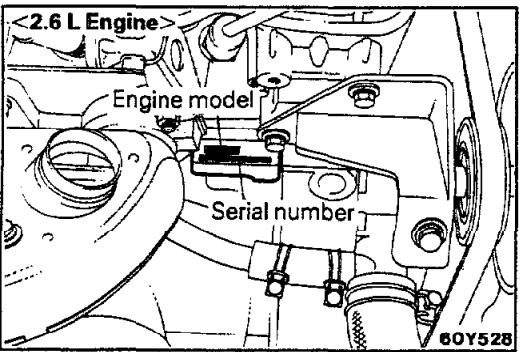

ENGINE MODEL STAMPING

N00CG-

The engine model is stamped on the right front side on the top edge of the cylinder block (for 2.6-liter engines). For 3.0-liter engines, it is stamped at the right rear of the top of the cylinder block.

These engine model numbers are as shown in the following.

Engine model	Engine displacement
G54B	2.555 liters (155.9 cu.in.)
6G72	2.972 liters (181.4 cu.in.)

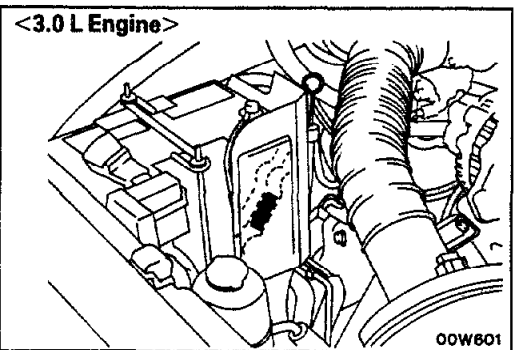

The engine serial number is stamped near the engine model number, and the serial number cycles, as shown below.

Engine serial number	Number cycling
AA0201 to YY9999	AA0201 ----> AA9999
	AB0001 ----> AY9999
	BA0001 ----> YY9999

BODY COLOR CODE

N00CH-

Exterior code	Body color
Monotone C46 H84 R82 S55 T86 W09 R48 X15	Brown (M) Silver (M) Red Beige (M) Blue (M) White Red (M) Black
Two-tone C1XC46X85 H1XH84X85 R2XR82X85 S1XS55X85 T6HT86H84 W6XW09X85 X2HX15H84	Brown (M)/ Black Silver (M)/ Black Red/ Black Beige (M)/ Black Blue (M)/ Silver (M) White/ Black Black/ Silver (M)

(M) : Metallic paint

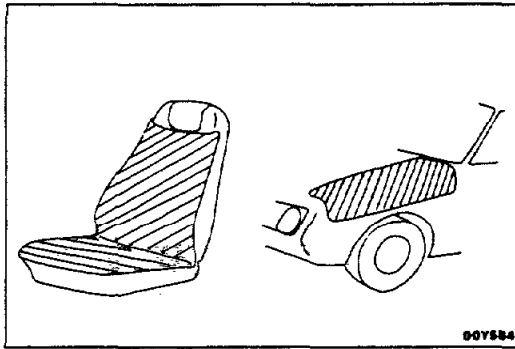

00Y584

PRECAUTIONS BEFORE SERVICE

PROTECTING THE VEHICLE

N000AAK

If there is a likelihood of damaging painted or interior parts during service operations, protect them with suitable covers (such as seat covers, fender covers, etc.).

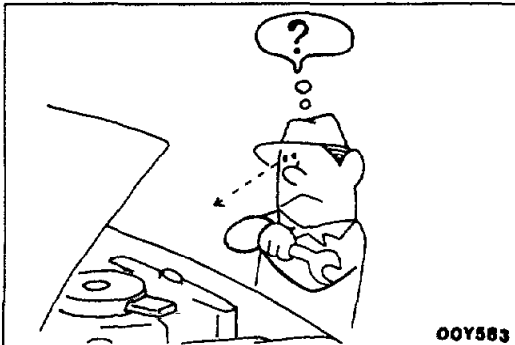

00Y583

REMOVAL AND DISASSEMBLY

When checking a malfunction, find the cause of the problem. If it is determined that removal and/or disassembly is necessary, perform the work by following the procedures contained in this Workshop Manual.

If punch marks or mating marks are made to avoid error in assembly and facilitate the assembly work, be sure to make them in locations which will have no detrimental effect on performance and/or appearances.

If an area having many parts, similar parts, and/or parts which are symmetrical right and left is disassembled, be sure to arrange the parts so that they do not become mixed during the assembly process.

1. Arrange the parts removed in the proper order.
2. Determine which parts are to be reused and which are to be replaced.
3. If bolts, nuts, etc., are to be replaced, be sure to use only the exact size specified.

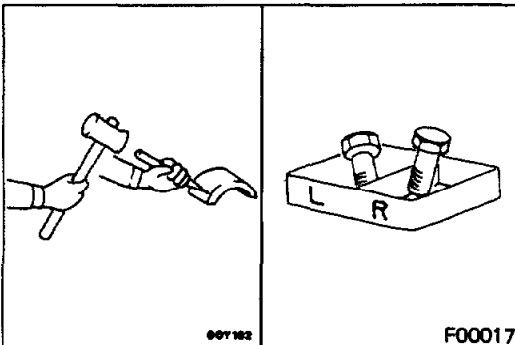

00Y182

F00017

SPECIAL TOOLS

If other tools are substituted for the special tools to do service or repair work, there is the danger that vehicle parts might be damaged, or the mechanic might be injured; therefore, be sure to use the special tool whenever doing any work for which the use of one is specified.

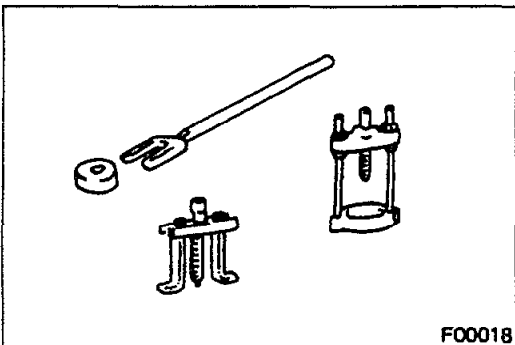

F00018

PARTS TO BE REPLACED

If any of the following parts are removed, they must be replaced with new parts.

1. Oil seals
2. Gaskets (except rocker cover gasket)
3. Packings
4. O-rings
5. Lock washers
6. Cotter pins
7. Self-locking nuts

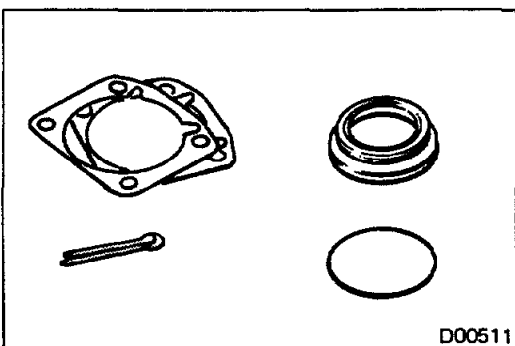

D00511

PARTS

When replacing parts, use MITSUBISHI genuine parts.

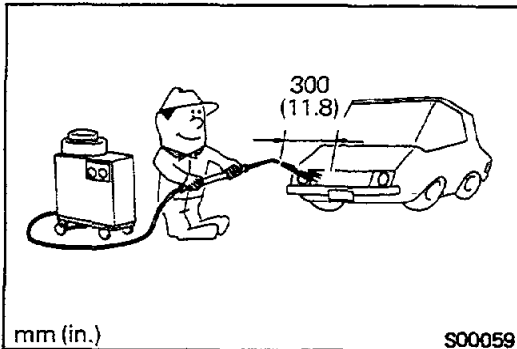

VEHICLE WASHING

If high-pressure car-washing equipment or steam car-washing equipment is used to wash the vehicle, be sure to maintain the spray nozzle at a distance of at least 300 mm (11.8 in.) from any plastic parts and all opening parts (doors, luggage compartment, etc.).

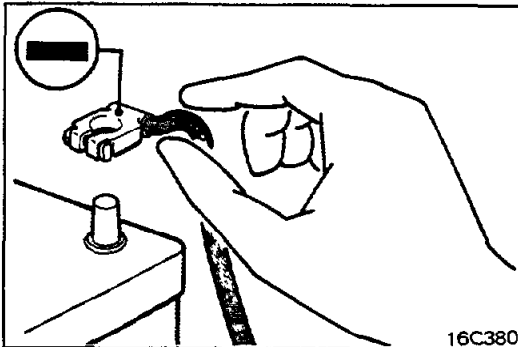

SERVICING ELECTRICAL SYSTEM

1. Note the following before proceeding with work on the electrical system.

Note that the following must never be done:

Unauthorized modifications of any electrical device or wiring, because such modifications might lead to a vehicle malfunction, over-capacity or short-circuit that could result in a fire in the vehicle.

2. When servicing the electrical system, disconnect the negative cable terminal from the battery.

Caution

1. **Before connecting or disconnecting the negative cable, be sure to turn off the ignition switch and the lighting switch.**

(If this is not done, there is the possibility of semiconductor parts being damaged.)

2. **After completion of the work steps [when the battery's negative (-) terminal is connected], warm up the engine and allow it to idle for approximately five minutes under the conditions described below, in order to stabilize engine control conditions, and then check to be sure that the idling is satisfactory. For 3.0L Engine models: If the engine rpm is high, switch OFF the ignition switch, and then, after switching it ON again, let the engine idle for 2 or 3 minutes.**

This will cause the engine rpm to decrease about 100 rpm, so repeat this procedure until the prescribed idling speed is reached.

Engine coolant temperature : 85°–95°C (185–203°F)

Lights, accessories : OFF

Transmission : neutral position

(Automatic transmission models: "N" or "P")

Steering wheel : neutral (center) position

WIRING HARNESSSES

1. Secure the wiring harnesses by using clamps. However, for any harness which passes to the engine or other vibrating parts of the vehicle, allow some slack within a range that does not allow the engine vibrations to cause the harness to come into contact with any of the surrounding parts. Then secure the harness by using a clamp. In addition, if a mounting indication mark (yellow tape) is on a harness, secure the indication mark in the specified location.

2. If any section of a wiring harness contacts the edge of a part, or a corner, wrap the section of the harness with tape or something similar in order to protect it from damage.

3. When disconnecting a connector, be sure to pull only the connector, not the harness.

4. Disconnect connectors which have catches by pressing in the direction indicated by the arrows in the illustration.

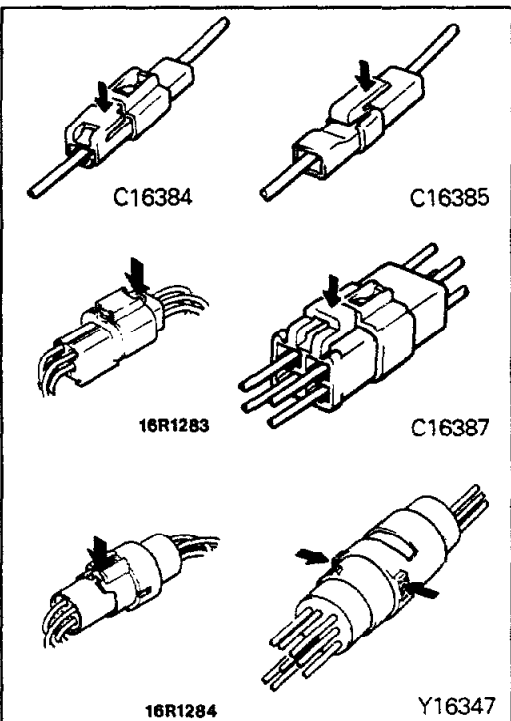
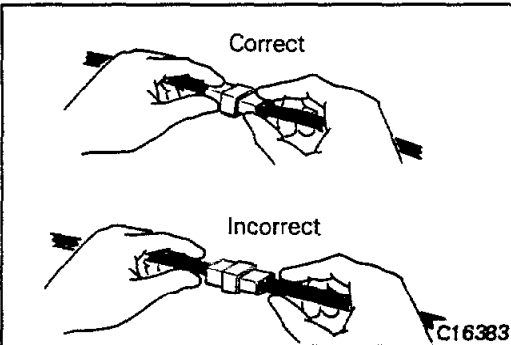
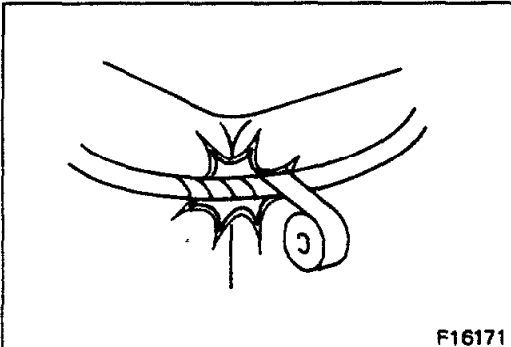
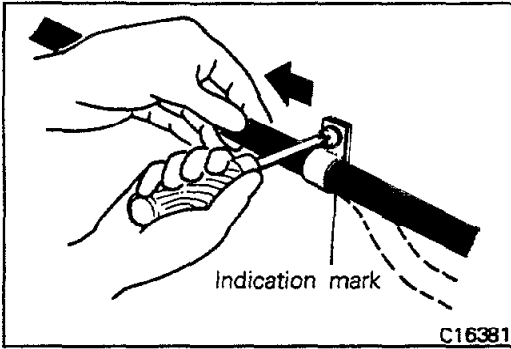

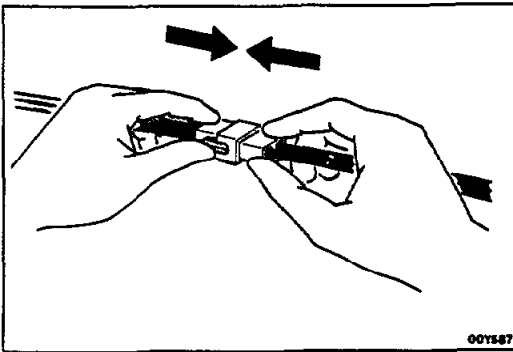

00Y587

5. Connect connectors which have catches by inserting the connectors until they snap.

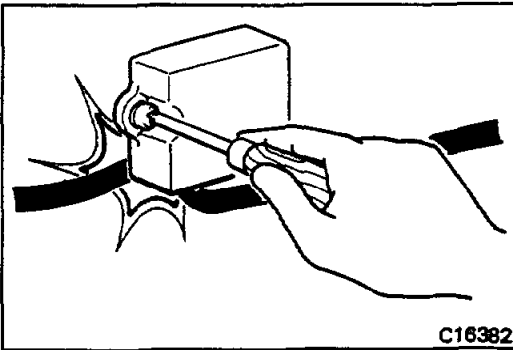

C16382

ELECTRICAL COMPONENTS

1. When installing any of the vehicle parts, be careful not to pinch or damage any of the wiring harnesses.

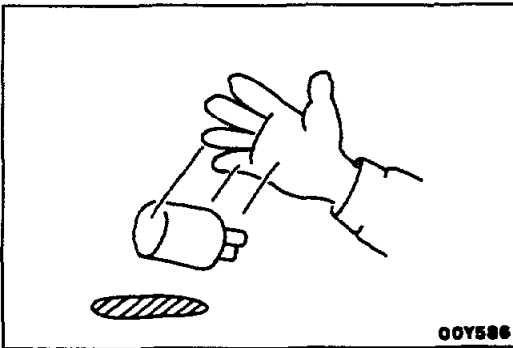

00Y586

2. Sensors, relays, etc., are sensitive to strong impacts. Handle them with care so that they are not dropped or mishandled.

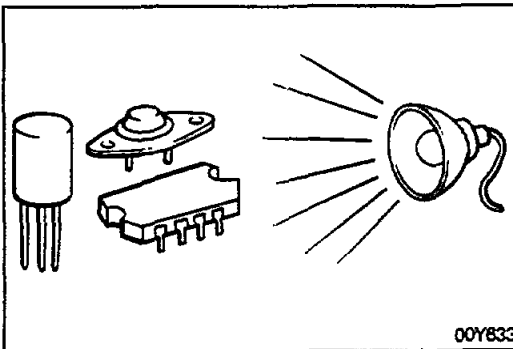

00Y633

3. The electronic parts used for relays, etc., are sensitive to heat. If any service which causes a temperature of 80°C (176°F) or more is performed, remove the part or parts in question before carrying out the service.

FUSES AND FUSIBLE LINKS

1. If a blown-out fuse is to be replaced, be sure to use only a fuse of the specified capacity. If a fuse of a capacity larger than that specified is used, parts may be damaged and the circuit may not be protected adequately.

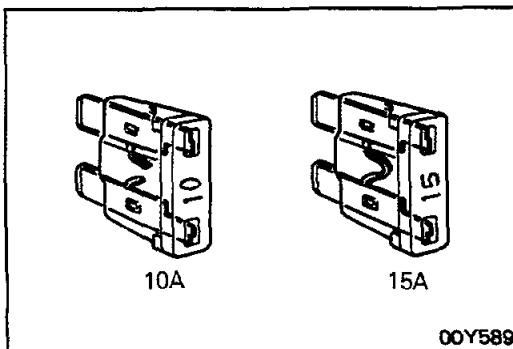

00Y589

Caution

1. If a fuse is blown-out, be sure to eliminate the cause of the problem before installing a new fuse.
2. Check the condition of fuse holders. If rust or dirt is found, clean metal parts with a fine-grained sandpaper until proper metal-to-metal contact is made. Poor contact of any fuse holder will often lead to voltage drop or heating in the circuit and could result in improper circuit operation.

Nominal size	SAE gauge No.	Permissible current	
		In engine compartment	Other areas
0.3 mm ²	AWG 22	–	5A
0.5 mm ²	AWG 20	7A	13A
0.85 mm ²	AWG 18	9A	17A
1.25 mm ²	AWG 16	12A	22A
2.0 mm ²	AWG 14	16A	30A
3.0 mm ²	AWG 12	21A	40A
5.0 mm ²	AWG 10	31A	54A

2. If additional optional equipment is to be installed in the vehicle, follow the procedure listed in the appropriate instruction manual; however, be sure to pay careful attention to the following points:

- (1) In order to avoid overloading the wiring, take the electrical current load of the optional equipment into consideration, and determine the appropriate wire size.
- (2) Where possible, route the wiring through the existing harnesses.
- (3) If an ammeter or similar instrument is to be connected to a live-wire circuit, use tape to protect the wire, use a clamp to secure the wire, and make sure that there is no contact with any other parts.
- (4) Be sure to provide a fuse for the load circuit of the optional equipment.

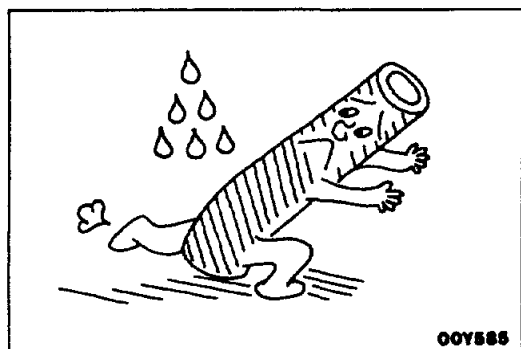

TUBES AND OTHER RUBBER PARTS

Be careful to avoid spilling any gasoline, oil, etc., or rubber parts, they might be adversely affected.

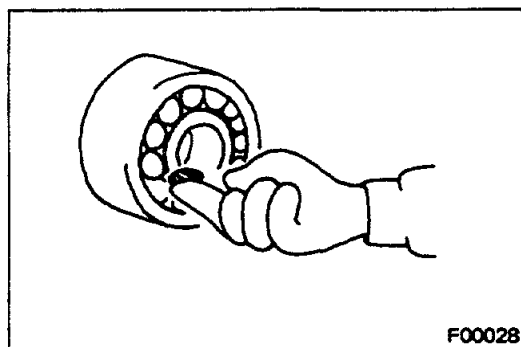

LUBRICANTS

In accordance with the instructions in this Service Manual, apply the specified lubricants in the specified locations during assembly and installation.

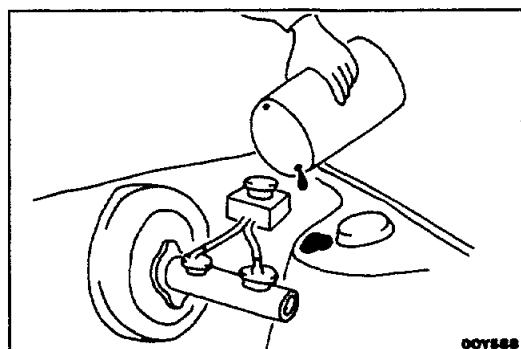

BRAKE FLUID

Be careful to avoid spilling any brake fluid on painted surfaces, because the paint coat might be discolored or damaged.

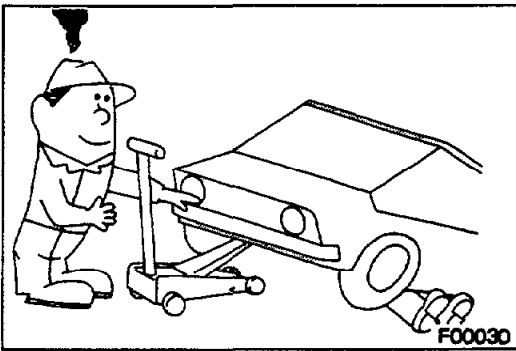

DOING SERVICE WORK IN GROUPS OF TWO OR MORE TECHNICIANS

If the service work is to be done by two or more technicians working together, extra caution must be taken.

NOTE ON INSTALLATION OF RADIO EQUIPMENT

The computers of the electronic control system has been designed so that external radio waves will not interfere with their operation.

However, if antenna or cable of amateur transceiver etc. is routed near the computers, it may affect the operation of the computers, even if the output of the transceiver is no more than 25W.

To protect each of the computers from interference by transmitter (hum, transceiver, etc.), the following should be observed.

1. Install the antenna on the roof or rear bumper.
2. Because radio waves are emitted from the coaxial cable of the antenna, keep it 200 mm (8 in.) away from the computers and the wiring harness. If the cable must cross the wiring harness, route it so that it runs at right angles to the wiring harness.
3. The antenna and the cable should be well matched, and the standing-wave ratio* should be kept low.
4. A transmitter having a large output should not be installed in the vehicle.
5. After installation of transmitter, run the engine at idle, emit radio waves from the transmitter and make sure that the engine is not affected.

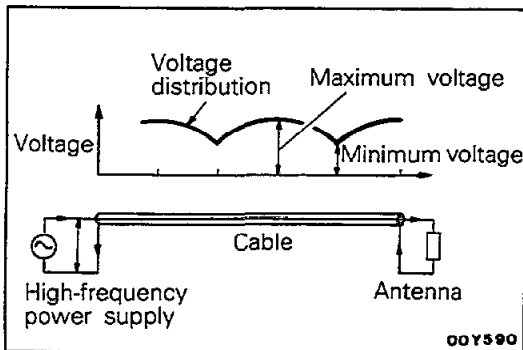

*STANDING-WAVE RATIO

If an antenna and a cable having different impedances are connected, the input impedance Z_i will vary in accordance with the length of the cable and the frequency of the transmitter, and the voltage distribution will also vary in accordance with the location.

The ratio between this maximum voltage and minimum voltage is called the standing-wave ratio. It can also be represented by the ratio between the impedances of the antenna and the cable.

The amount of radio waves emitted from the cable increases as the standing-wave ratio increases, and this increases the possibility of the electronic components being adversely affected.

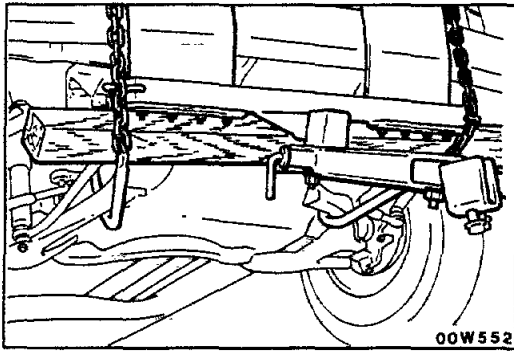

TOWING AND HOISTING

N00GA--

This vehicle can only be towed from the front with conventional sling-type equipment and tow chain with grab hooks.

If a vehicle is towed from the rear, use a tow dolly.

A lumber spacer (4" x 4" x 55" wood beam) should be placed forward of under guard and under towing hook/shipping tie down hook.

Then, attach J-hook to the lower arm.

A safety chain system must be used. This system must be completely independent of the primary lifting and towing attachment. Care must be taken in the installation of safety chains to insure they do not cause damage to bumper, painted surfaces or lights.

LIFTING-GROUND CLEARANCE

Towed vehicle should be raised until wheels are a minimum of 10 cm (4 in.) from the ground. Be sure there is adequate ground clearance at the opposite end of the vehicle, especially when towing over rough terrain or when crossing sharp rises such as curbs. If necessary, ground clearance can be increased by removing the wheels from the lifted end of the disabled vehicle and carrying the lifted end closer to the ground. A 20 cm (8 in.) ground clearance must be maintained between brake drums and ground.

FRONT TOWING PICKUP

The vehicle may be towed on its rear wheels for extended distances, provided the parking brake is released.

Make certain the transmission remains in "NEUTRAL".

SAFETY PRECAUTIONS

The following precautions should be taken when towing the vehicle.

1. Remove exhaust tips and any other optional equipment, that interface with the towing sling. Padding (heavy shop towel or carpeting) should be placed between the towing sling cross bar and any painted surfaces, and bumper surfaces.
2. A safety chain system completely independent of the primary lifting and towing attachment must be used.
3. Any loose or protruding parts of damaged vehicle such as hoods, doors, fenders, trim, etc., should be secured prior to moving the vehicle.
4. Operator should refrain from going under a vehicle unless the vehicle is adequately supported by safety stands.
5. Never allow passengers to ride in a towed vehicle.
6. State and local rules and regulations must be followed when towing a vehicle.

HOISTING

POST TYPE

Special care should be taken when raising the vehicle on a frame contact type hoist. The hoist must be equipped with the proper adapters in order to support the vehicle at the proper locations. (Shown in the illustration)

Conventional hydraulic hoists may be used after determining that the adapter plates will make firm contact with the side frame.

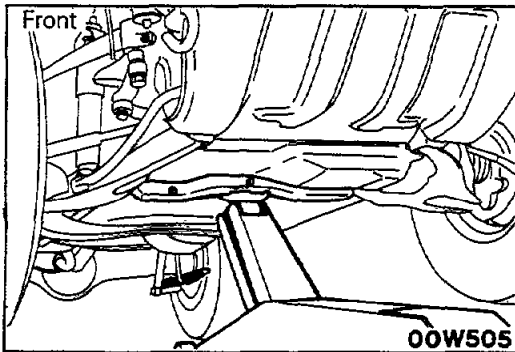

FLOOR JACK

A regular floor jack may be used under the front crossmember or rear axle housing.

Caution

1. A floor jack must never be used on any part of the underbody.
2. Do not attempt to raise one entire side of the vehicle by placing a jack midway between front and rear wheels. This practice may result in permanent damage to the body.

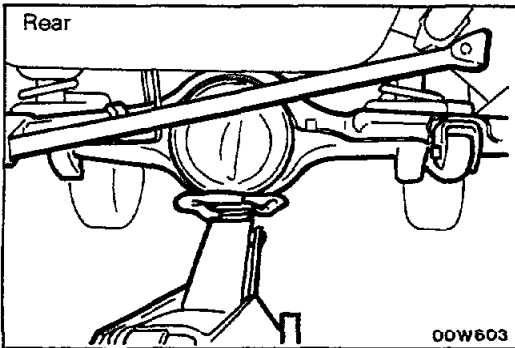

EMERGENCY JACKING

Jack receptacles are located at the No. 2 crossmember and rear axle housing to accept the jack supplied with the vehicle for emergency road service. Always block the opposite wheels and jack only on a level surface.

FRAME CONTACT SUPPORT LOCATIONS

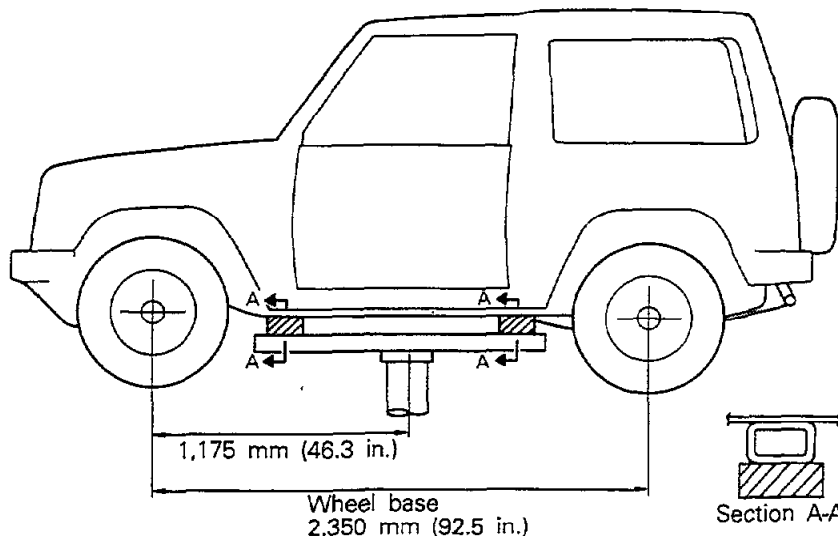

NOTE

The locations of the support point shown as Section A-A are the same as those of the twin post hoist shown in the next page.

LIFTING AND JACKING SUPPORT LOCATIONS

<2.6L Engine>

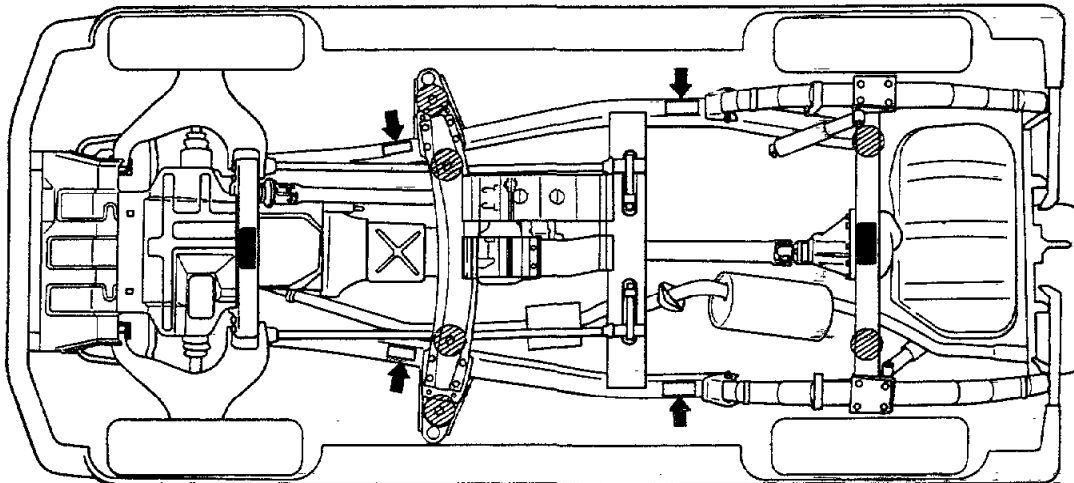

<3.0L Engine>

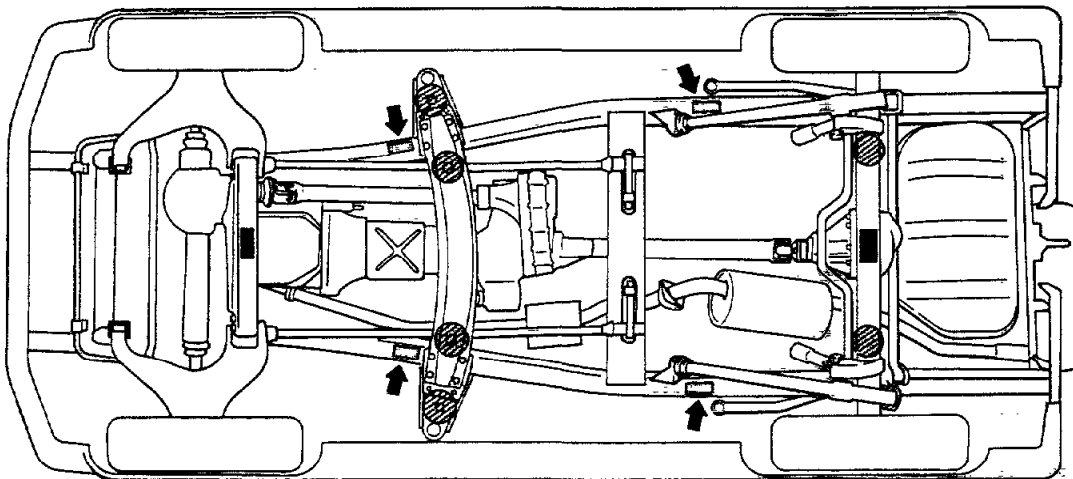

00W588

00W605

- ← Twin post hoist
- Floor jack
- Emergency jacking (jack supplied with the vehicle)

GENERAL DATA AND SPECIFICATIONS

N00HA--

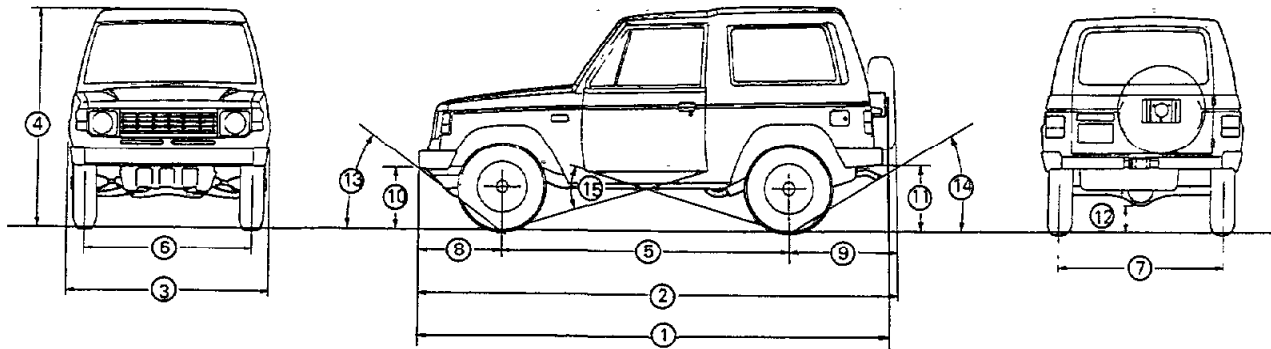

00W606

<2-door vehicles>

Description	Models	L042G		L141G	
		TNSL F/H	TNJL F/H	TRJL F/H	TRUL F/H
Vehicle dimensions	mm (in.)				
Overall length					
Without spare tire	①	3,900 (153.5)	3,905 (153.7)	3,905 (153.7)	3,905 (153.7)
With spare tire	②	3,935 (154.9)	3,940 (155.1)	3,940 (155.1)	3,940 (155.1)
Overall width	③	1,680 (66.1)	1,680 (66.1)	1,680 (66.1)	1,680 (66.1)
Overall height	④	1,840 (72.4)	1,850 (72.8)	1,850 (72.8)	1,850 (72.8)
Wheelbase	⑤	2,350 (92.5)	2,350 (92.5)	2,350 (92.5)	2,350 (92.5)
Tread	Front	⑥	1,400 (55.1)	1,400 (55.1)	1,400 (55.1)
	Rear	⑦	1,375 (54.1)	1,415 (55.7)	1,415 (55.7)
Overhang	Front	⑧	685 (27.0)	685 (27.0)	685 (27.0)
	Rear	⑨	900 (35.4)	905 (35.6)	905 (35.6)
Height at curb weight	(wt.)				
Front bumper to ground	⑩	480 (18.9)	490 (19.3)	490 (19.3)	490 (19.3)
Rear bumper to ground	⑪	440 (17.3)	450 (17.7)	450 (17.7)	450 (17.7)
Minimum running ground clearance	⑫	210 (8.3)	215 (8.5)	215 (8.5)	215 (8.5)
Angle of approach	⑬	38°	38°	38°	38°
Angle of departure	⑭	28°	28°	28°	28°
Ramp breakover angle	⑮	21°	21°	21°	21°
Vehicle weights	kg (lbs.)				
Curb weight		1,455 (3,207)	1,585 (3,494)	1,600 (3,527)	1,605 (3,538)
Gross vehicle weight rating		1,910 (4,210)	2,200 (4,850)	2,200 (4,850)	2,200 (4,850)
Gross axle weight rating	Front	1,100 (2,425)	1,100 (2,425)	1,100 (2,425)	1,100 (2,425)
	Rear	1,450 (3,197)	1,600 (3,527)	1,600 (3,527)	1,600 (3,527)
Seating capacity		2	2	2	2

Description	Models		L042G		L141G	
			TNSL F/H	TNJL F/H	TRJL F/H	TRUL F/H
Engine						
Model No.			G54B	6G72	6G72	6G72
Type			In-line OHC	V-type, OHC	V-type, OHC	V-type, OHC
Number of cylinders			4	6	6	6
Bore			91.1 mm (3.59 in.)	91.1 mm (3.59 in.)	91.1 mm (3.59 in.)	91.1 mm (3.59 in.)
Stroke			98.0 mm (3.86 in.)	76.0 mm (2.99 in.)	76.0 mm (2.99 in.)	76.0 mm (2.99 in.)
Piston displacement			2,555 cm ³ (155.9 cu.in.)	2,972 cm ³ (181.4 cu.in.)	2,972 cm ³ (181.4 cu.in.)	2,972 cm ³ (181.4 cu.in.)
Compression ratio			8.7	8.9	8.9	8.9
Firing order			1-3-4-2	1-2-3-4-5-6	1-2-3-4-5-6	1-2-3-4-5-6
Basic ignition timing			7°BTDC ± 2°	5°BTDC ± 2°	5°BTDC ± 2°	5°BTDC ± 2°
Transmission & transfer case						
Model No.			KM145	V5MT1	KM148	KM148
Type			5-speed manual	5-speed manual	4-speed automatic	4-speed automatic
Gear ratio						
Transmission	1st		3.967	3.918	2.826	2.826
	2nd		2.136	2.261	1.493	1.493
	3rd		1.360	1.395	1.000	1.000
	4th		1.000	1.000	0.688	0.688
	5th		0.856	0.829	-	-
	Reverse		3.587	3.925	2.703	2.703
Transfer case	High		1.000	1.000	1.000	1.000
	Low		1.944	1.925	1.925	1.925
Final ring gear ratio			4.625	4.625	4.625	4.625
Clutch						
Type			Dry single disc & diaphragm spring	Dry single disc & diaphragm spring	-	-
Chassis						
Tire size			P225/75R15	P235/75R15		
Front suspension						
Type			Independent double-wishbone	Independent double-wishbone		
Rear suspension						
Type			Rigid axle	Rigid axle		
Brakes						
Type	Front		Disc	Disc		
	Rear		Drum (Leading and trailing)	Drum (Leading and trailing)		
Power steering						
Gear type			Integral type (Recirculating ball nut)	Integral type (Recirculating ball nut)		
Gear ratio			16.4	16.4		
Fuel tank capacity	liters (gals.)		60 (15.9)	75 (19.8)		



<4-door vehicles>

Description		Models	L146G		
			VMNJL F/H	VMRJL F/H	WMRUL F/H
Vehicle dimensions mm (in.)					
Overall length					
Without spare tire	①	4,570 (179.9)	4,570 (179.9)	4,570 (179.9)	
With spare tire	②	4,605 (181.3)	4,605 (181.3)	4,605 (181.3)	
Overall width	③	1,680 (66.1)	1,680 (66.1)	1,680 (66.1)	
Overall height	④	1,890 (74.4)	1,890 (74.4)	1,890 (74.4)	
Wheelbase	⑤	2,695 (106.1)	2,695 (106.1)	2,695 (106.1)	
Tread	Front	⑥	1,400 (55.1)	1,400 (55.1)	1,400 (55.1)
	Rear	⑦	1,415 (55.7)	1,415 (55.7)	1,415 (55.7)
Overhang	Front	⑧	745 (29.3)	745 (29.3)	745 (29.3)
	Rear	⑨	1,165 (45.9)	1,165 (45.9)	1,165 (45.9)
Height at curb weight (wt.)					
Front bumper to ground	⑩	490 (19.3)	490 (19.3)	490 (19.3)	
Rear bumper to ground	⑪	450 (17.7)	450 (17.7)	450 (17.7)	
Minimum running ground clearance	⑫	215 (8.5)	215 (8.5)	215 (8.5)	
Angle of approach	⑬	38°	38°	38°	
Angle of departure	⑭	28°	28°	28°	
Ramp breakover angle	⑮	18°	18°	18°	
Vehicle weights kg (lbs.)					
Curb weight		1,780 (3,924)	1,795 (3,957)	1,805 (3,979)	
Gross vehicle weight rating		2,400 (5,291)	2,400 (5,291)	2,400 (5,291)	
Gross axle weight rating	Front	1,100 (2,425)	1,100 (2,425)	1,100 (2,425)	
	Rear	1,600 (3,527)	1,600 (3,527)	1,600 (3,527)	
Seating capacity		5	5	5	
Engine					
Model No.		6G72	6G72	6G72	
Type		V-type, OHC	V-type, OHC	V-type, OHC	
Number of cylinders		6	6	6	
Bore		91.1 mm (3.59 in.)	91.1 mm (3.59 in.)	91.1 mm (3.59 in.)	
Stroke		76.0 mm (2.99 in.)	76.0 mm (2.99 in.)	76.0 mm (2.99 in.)	
Piston displacement		2,972 cm ³ (181.4 cu.in.)	2,972 cm ³ (181.4 cu.in.)	2,972 cm ³ (181.4 cu.in.)	
Compression ratio		8.9	8.9	8.9	
Firing order		1-2-3-4-5-6	1-2-3-4-5-6	1-2-3-4-5-6	
Basic ignition timing		5°BTDC ±2°	5°BTDC ±2°	5°BTDC ±2°	

Description		Models	L146G		
		VMNJL F/H	VMRJL F/H	WMRUL F/H	
Transmission & transfer case					
Model No.		V5MT1	KM148	KM148	
Type		5-speed manual	4-speed automatic	4-speed automatic	
Gear ratio					
Transmission					
1st		3.918	2.826	2.826	
2nd		2.261	1.493	1.493	
3rd		1.395	1.000	1.000	
4th		1.000	0.688	0.688	
5th		0.829	-	-	
Reverse		3.925	2.703	2.703	
Transfer case					
High		1.000	1.000	1.000	
Low		1.925	1.925	1.925	
Final ring gear ratio		4.625	4.625	4.625	
Clutch					
Type		Dry single disc & diaphragm spring	-	-	
Chassis					
Tire size		P235/75 R15			
Front suspension					
Type		Independent double-wishbone			
Rear suspension					
Type		Rigid axle			
Brakes					
Type		Front	Disc		
		Rear	Drum (Leading and trailing)		
Power steering					
Gear type		Integral type (Recirculating ball nut)			
Gear ratio		16.4			
Fuel tank capacity		liter (gal.)	92 (24.3)		

TIGHTENING TORQUE

N00JA-

Description	Head mark 		Head mark 	
	Nm	ft.lbs.	Nm	ft.lbs.
Thread for general purposes (size x pitch) mm				
6 x 1.0	3.0–3.9	2.2–2.9	4.9–7.8	3.6–5.8
8 x 1.25	7.9–12	5.8–8.7	13–19	9.4–14
10 x 1.25	16–23	12–17	27–39	20–29
12 x 1.25	29–43	21–32	47–72	35–53
14 x 1.5	48–70	35–52	77–110	57–85
16 x 1.5	67–100	51–77	130–160	90–120
18 x 1.5	100–150	74–110	180–230	130–170
20 x 1.5	150–190	110–140	160–320	190–240
22 x 1.5	200–260	150–190	340–430	250–320
24 x 1.5	260–320	190–240	420–550	310–410

Description	Nm	ft.lbs.	Remarks
Taper thread for pipes (size)			
PT 1/8	7.9–12 16–19	5.8–8.7 12–14	Internal thread: Aluminum Internal thread: Cast iron
PT 1/4	19–30 34–45	14–22 25–33	Internal thread: Aluminum Internal thread: Cast iron
PT 3/8	39–54 58–73	29–40 43–54	Internal thread: Aluminum Internal thread: Cast iron
Taper thread for dry sealed pipes (size)			
NPTF 1/16	4.9–7.8 7.9–12	3.6–5.8 5.8–8.7	Internal thread: Aluminum Internal thread: Cast iron
NPTF 1/8	7.9–12 16–19	5.8–8.7 12–14	Internal thread: Aluminum Internal thread: Cast iron
NPTF 1/4	19–13 34–45	14–22 25–33	Internal thread: Aluminum Internal thread: Cast iron

NOTE