

ELECTRICAL

CONTENTS

NO8AA--

ACCESSORY	224	Inspection Terminal	17
Cigarette Lighter	226	Relay and Control Unit	3
Clock	226	Sensor <2.6L Engine>	6
Troubleshooting	225	Sensor <3.0L Engine>	8
AUDIO SYSTEM	227	HORN	222
Antenna	256	Troubleshooting	223
Front Speaker	255	IGNITION SYSTEM	143
Radio and Tape Player	254	Distributor <2.6L Engine>	158
Rear Speaker	255	Distributor <3.0L Engine>	160
Troubleshooting	228	Ignition Switch	162
AUTOMATIC FREE-WHEELING HUB		Ignition System <2.6L Engine>	151
INDICATOR SYSTEM	261	Ignition System <3.0L Engine>	155
Automatic Free-wheeling Hub	264	Service Adjustment Procedures	147
Pulse Generator	263	Centrifugal Timing Control Device	
Troubleshooting	262	Inspection <2.6L Engine only>	149
BACK DOOR WINDOW DEFOGGER	257	High Tension Cable Spark Test	150
Defogger switch	259	Ignition Timing Adjustment	
Printed Heater Lines	260	<2.6L Engine>	147
Troubleshooting	258	Ignition Timing Adjustment	
CHARGING SYSTEM	116	<3.0L Engine>	148
Alternator	126	Spark Plug Cable Test	150
Service Adjustment Procedures	122	Spark Plug Test	150
Battery Charging	126	Vacuum Timing Control Device	
Battery Inspection	125	Inspection <2.6L Engine only>	149
Charging System Inspection	122	Troubleshooting	145
Troubleshooting	118	INSPECTION OF HARNESS CONNECTOR	18
ELECTRICAL SYSTEM PARTS LOCATION	3	Check for Improper Engagement of	
Diode	16	Terminal	18
Fusible Link and Fuse	10	Continuity and Voltage Test for Connector	18
Grounding <2.6L Engine>	12	Engaging and Disengaging of Connector	
Ground <3.0L Engine>	14	Terminal	18

LIGHTING SYSTEM	179	Back Door Lock Circuit	111
Column Switch	200	Buzzer Circuit	84
Dimmer Control Switch	202	Central Locking System Circuit	100
Hazard Warning Switch	201	Cigarette Lighter/Clock Circuit	94
Headlight	199	Charging Circuit	51
Service Adjustment Procedures	198	Defogger Circuit	95
Headlight Aiming	198	Dome Light Circuit	78
Troubleshooting	180	Dual Air Conditioner Circuit	108
METERS AND GAUGES	163	Feed Back Carburetor Circuit	52
3-meter Unit	175	Headlight Circuit	64
Combination Meter	173	Heater Circuit	102
Indicators and Warning Lights	177	Horn Circuit	112
Service Adjustment Procedures	170	Ignition Circuit	49
Engine coolant Temperature Gauge		Instrument Panel Illumination Circuit	76
Simple Test	172	Meter Circuit	80
Engine coolant Temperature Gauge Unit		M.P.I. Circuit	56
Inspection	172	Overdrive Control System Circuit	60
Fuel Gauge Simple Test	171	Power Window Circuit	96
Fuel Gauge Unit Inspection	171	Radio/Cassette Deck Circuit	90
Oil Pressure Gauge Simple Test	172	Single Air Conditioner Circuit	104
Oil Pressure Gauge Unit Current Check	173	Starting Circuit	47
Speedometer Inspection	170	Stop Light Circuit	74
Tachometer Inspection <2.6L Engine>	170	Sunroof Circuit	113
Tachometer Inspection <3.0L Engine>	170	Tail Light, Position Light, Rear Side	
Voltage Meter Simple Test	173	Marker Light, License Plate Light and	
Troubleshooting	165	Back-up Light Circuit	66
STARTING SYSTEM	133	Turn-Signal and Hazard Light Circuit	70
Starter Motor	136	Wiper and Washer Circuit	86
WIPER AND WASHER SYSTEM	203	How to Read Wiring Diagrams	29
Column Switch	219	Overall Wiring Diagram	36
Headlight Washer	218	Engine Compartment <2.6L Engine>	38
Rear Washer	217	Engine Compartment <3.0L Engine>	40
Rear Wiper	215	Instrument Panel	42
Rear Wiper and Washer Switch	220	Interior and Frame <4-door vehicles>	44
Troubleshooting	206	Interior and Frame <2-door vehicles>	46
Windshield Washer	216	AUTO-CRUISE CONTROL	
Windshield Wipers	212	SYSTEM	REFER TO GROUP 14
WIRING HARNESS	21	BACK DOOR LOCK	REFER TO GROUP 23
Centralized Junction	114	BUZZER	REFER TO GROUP 23
Circuit Diagram	47	CENTRAL DOOR LOCKING	
Auto-Cruise Control System Circuit	62	SYSTEM	REFER TO GROUP 23
Automatic Free-Wheeling Hub Indicator		POWER WINDOW	REFER TO GROUP 23
System Circuit	85	SUNROOF	REFER TO GROUP 23

ELECTRICAL SYSTEM PARTS LOCATION

RELAY AND CONTROL UNIT

N08BA--

Name	Symbol	Name	Symbol
Air conditioner relay A, B	G	Heater relay	F
Automatic free-wheeling hub indicator control unit	H	Intermittent wiper relay	E
Auto choke relay <2.6L Engine>	A	Intermittent rear wiper relay	H
Automatic speed control unit	J	Light control relay	C
Choke relay <3.0L Engine>	C	M.P.I. control relay <3.0L Engine>	J
Condenser blower motor relay <2.6L Engine>	B	M.P.I. control unit <3.0L Engine>	I
Condenser blower motor relay <3.0L Engine>	D	Over drive relay <Vehicles with an automatic transmission>	H
Defogger timer unit	H	Power window power relay	E
Feed back carburetor control unit <2.6L Engine>	I	Seat belt warning timer	E
Hazard warning flasher unit	E	Turn-signal flasher unit	E
Headlight washer relay	E		

<2.6L Engine>

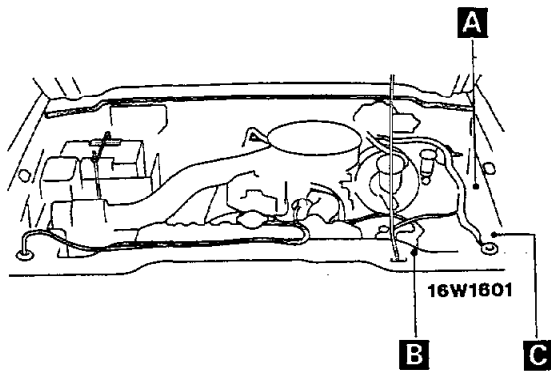

<3.0L Engine>

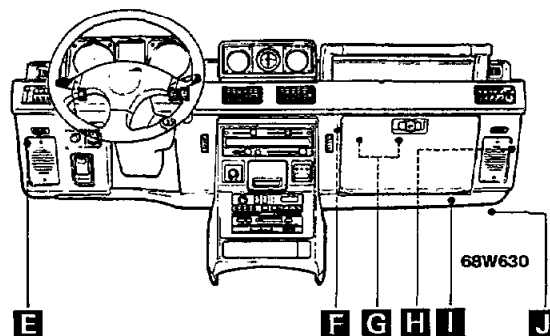
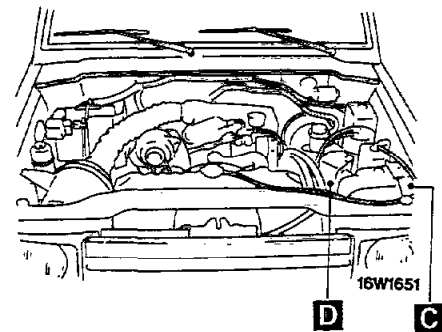

TSB Revision

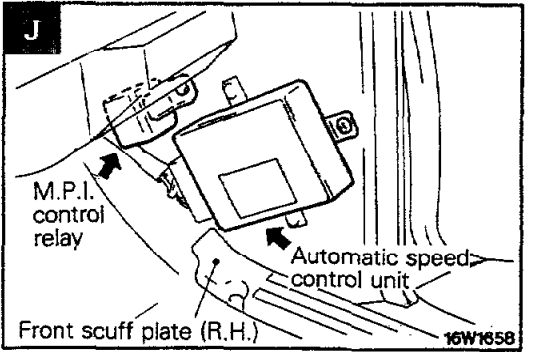
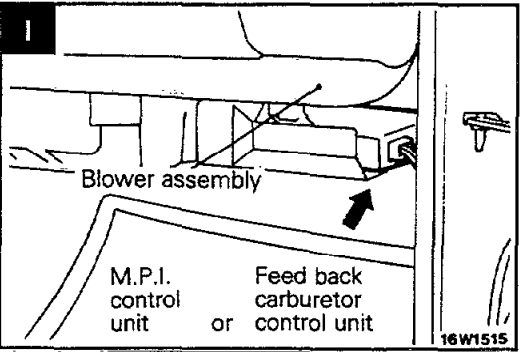
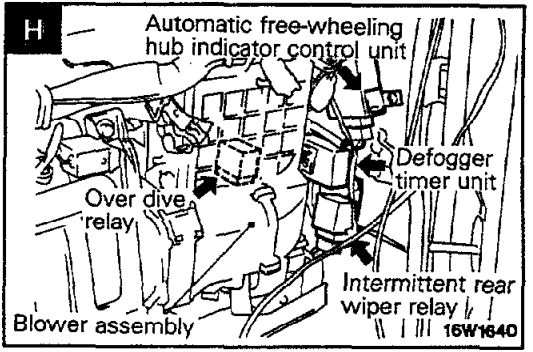
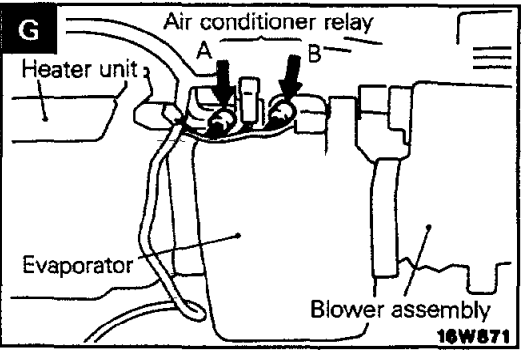
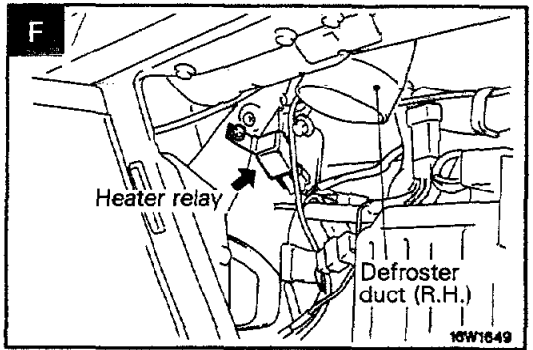
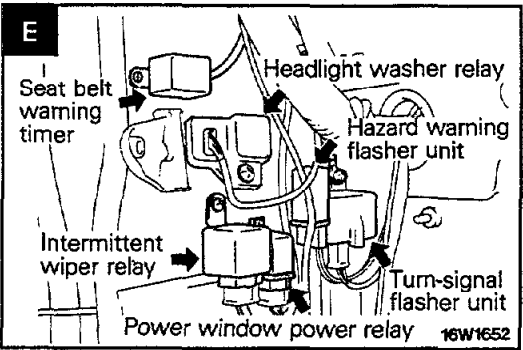
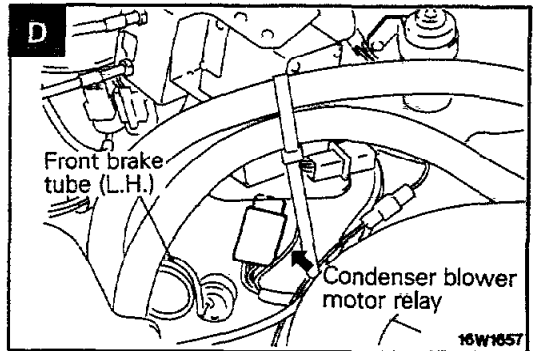
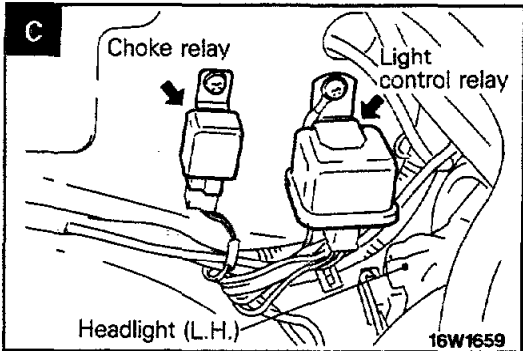
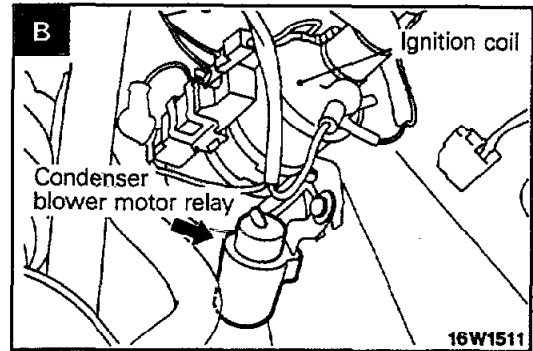
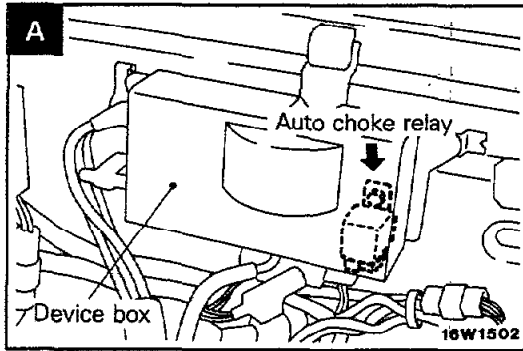

Name	Symbol	Name	Symbol
Air conditioner relay D, E <Vehicles with dual air conditioner>	M	Power window control relay	K
Door lock control unit	L	Sunroof control relay	N
Door lock power relay	L	Sunroof power relay	N

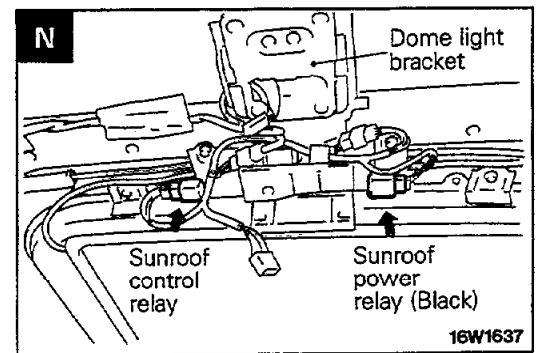
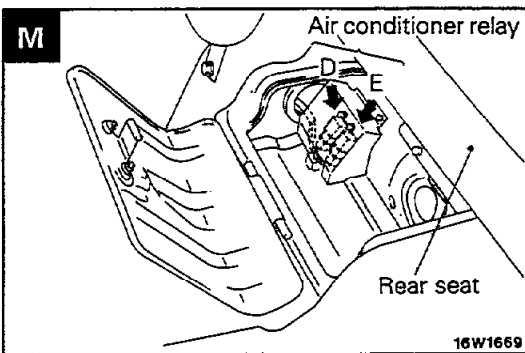
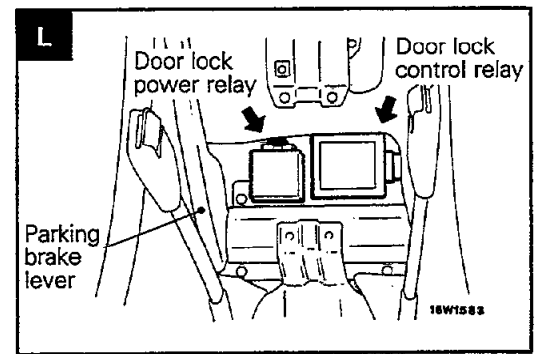
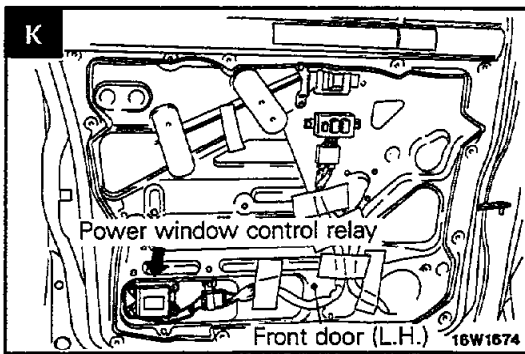
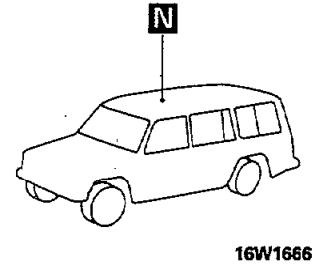
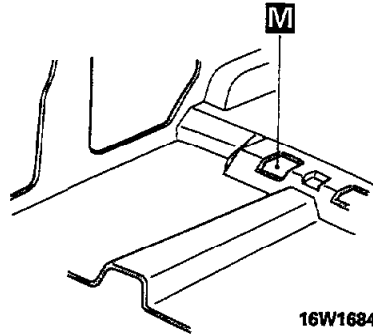
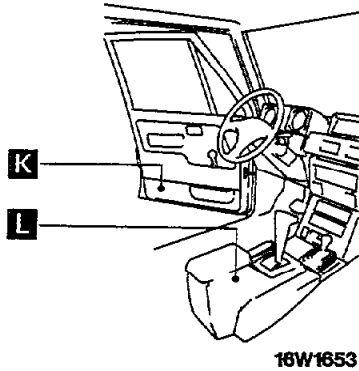

8-6 ELECTRICAL SYSTEM PARTS LOCATION – Sensor <2.6L Engine>

SENSOR <2.6L Engine>

Items	Symbol	Items	Symbol
Brake fluid level sensor	C	Oil pressure gauge unit	D
Engine coolant temperature gauge unit	A	Oxygen sensor	E
Engine coolant temperature sensor	A	Pulse generator	G
Fuel gauge unit	H	Throttle position sensor	B
		Vehicle-speed sensor	F

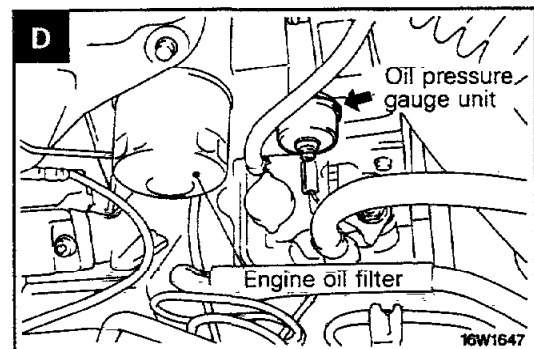
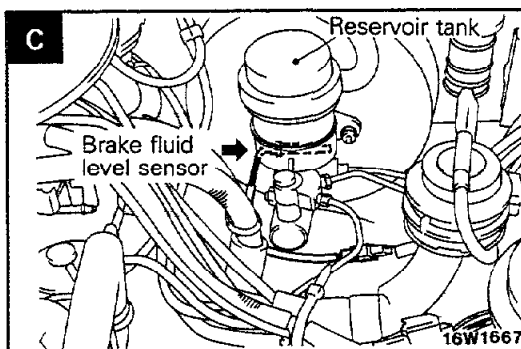
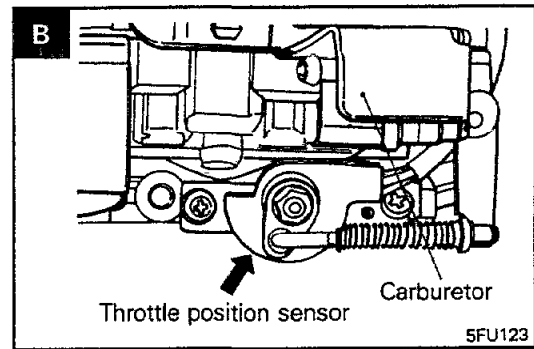
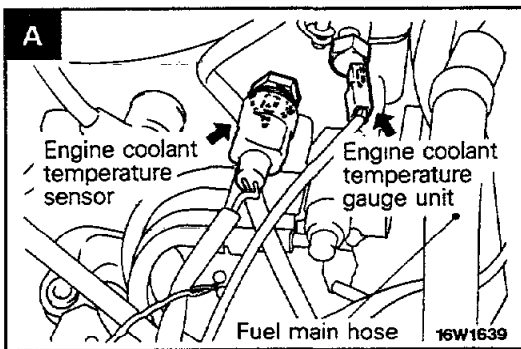
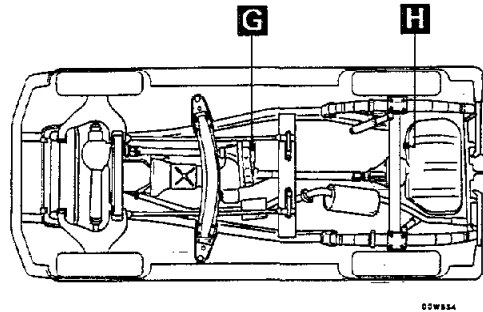
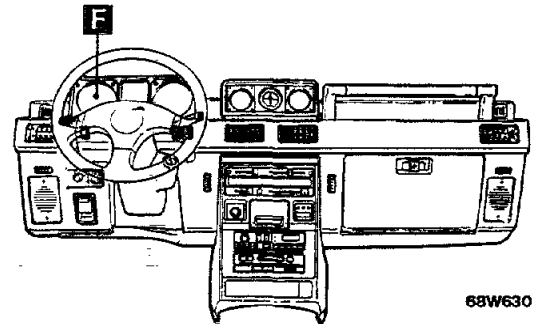
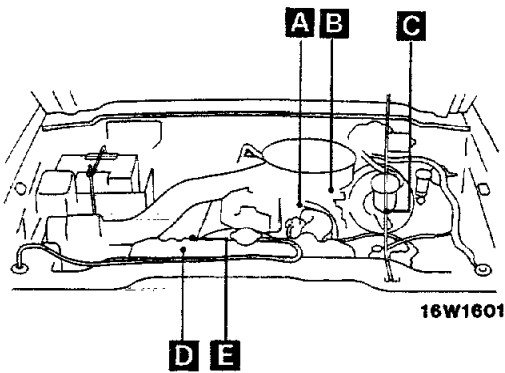

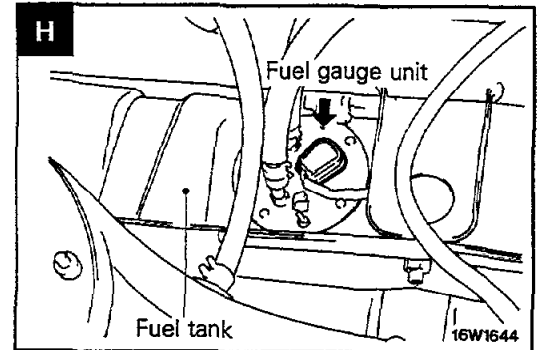
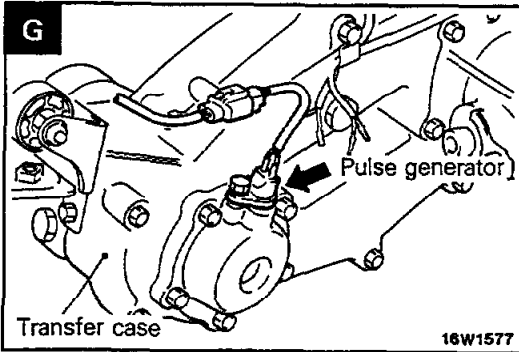
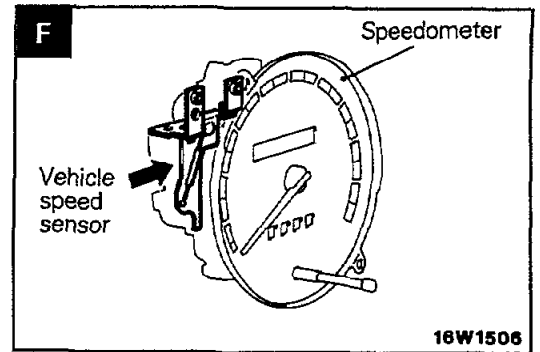
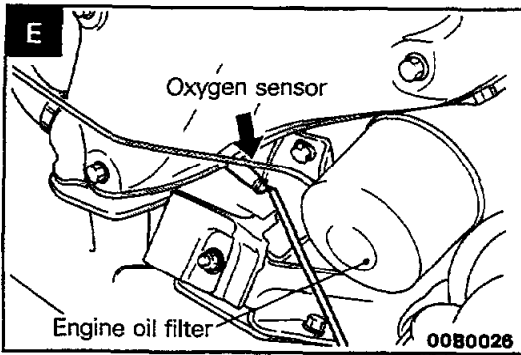

8-8 ELECTRICAL SYSTEM PARTS LOCATION – Sensor <3.0L Engine>

SENSOR <3.0L Engine>

Name	Symbol	Name	Symbol
Air-flow sensor	A	Fuel gauge unit	I
Automatic transmission oil temperature switch	J	Oil pressure gauge unit	E
Brake fluid level sensor	D	Oxygen sensor	G
Engine coolant temperature gauge unit	C	Pulse generator	H
Engine coolant temperature sensor	C	Throttle position sensor	B
Engine coolant temperature switch <Vehicles with an automatic transmission>	C	Vehicle-speed sensor	F

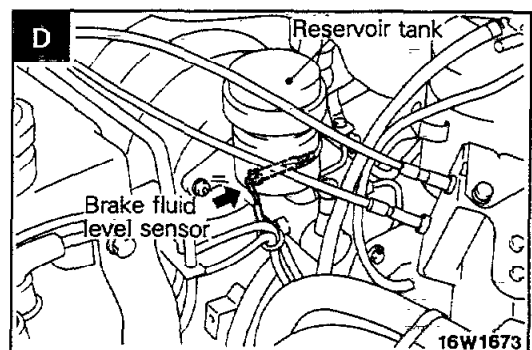
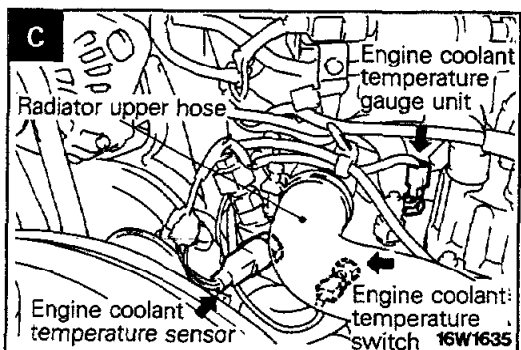
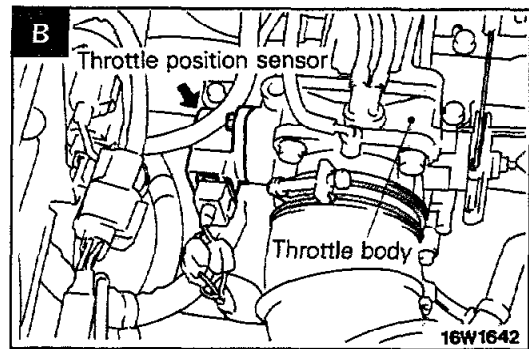
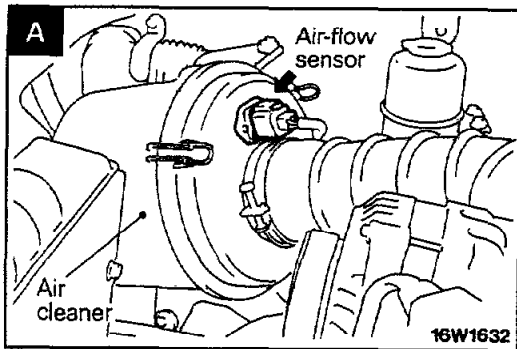
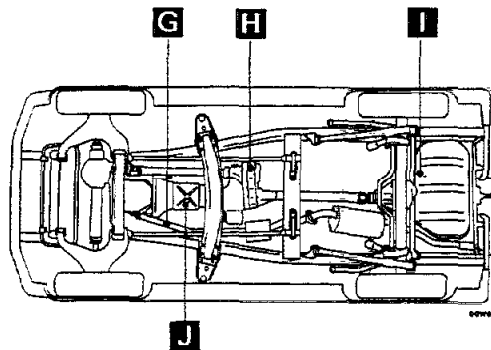
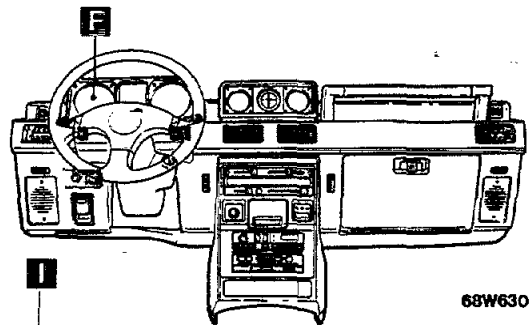
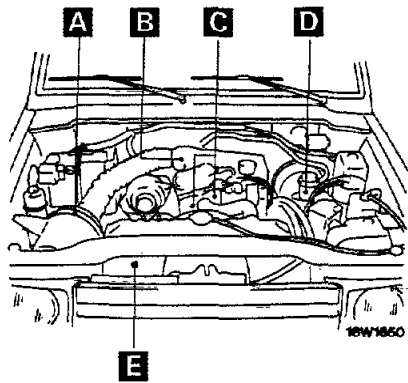

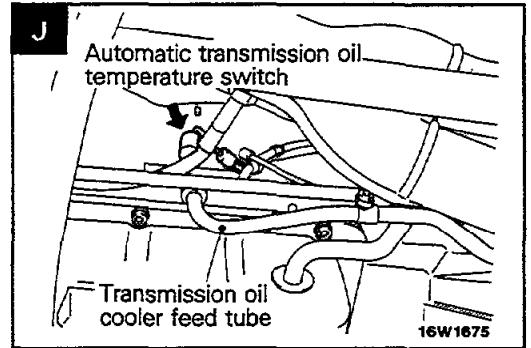
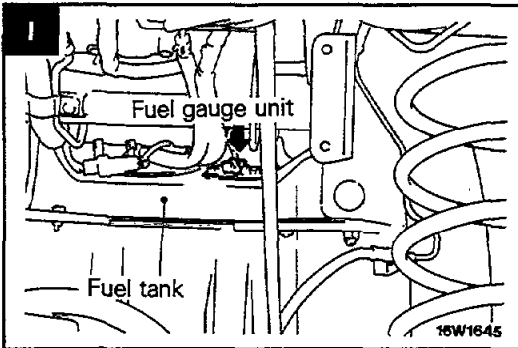
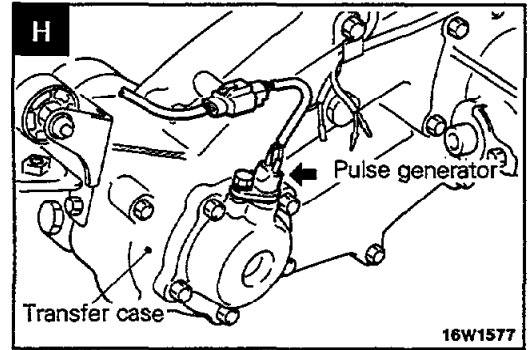
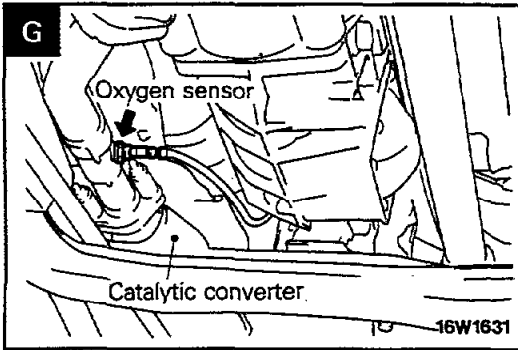
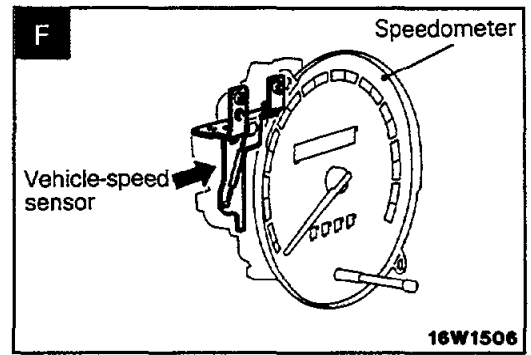
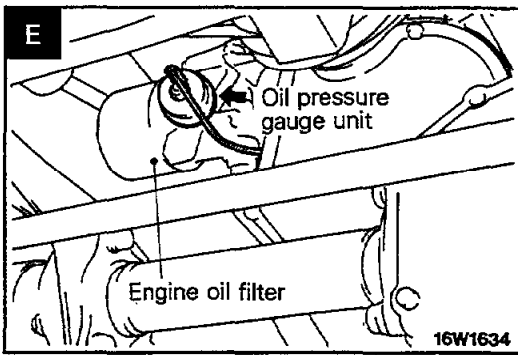

FUSIBLE LINK AND FUSE

Name	Symbol	Name	Symbol
Dedicated fuse (for air conditioner circuit)	H	Dedicated fusible link (for F.B.C. circuit)	A
Dedicated fuse (for center door locking circuit)	F	Main fusible link <2.6L Engine>	A
Dedicated fuse (for headlight circuit)	C	Main fusible link <3.0L Engine>	D
Dedicated fuse (for rear air conditioner circuit)	J	Multipurpose fuse	G
Dedicated fuse (for sunroof circuit)	I	Sub fusible link <2.6L Engine>	B
Dedicated fusible link (for defogger circuit) <2.6L Engine>	B	Sub fusible link <3.0L Engine>	D
Dedicated fusible link (for defogger circuit) <3.0L Engine>	E		

NOTE

For detailed information concerning the fusible links and fuses, refer to the section regarding CENTRALIZED JUNCTION (P.8-114)

<2.6L Engine>

<3.0L Engine>

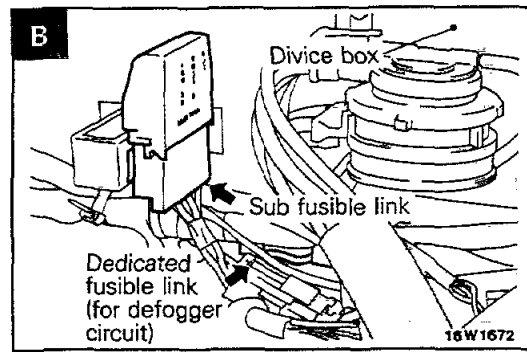
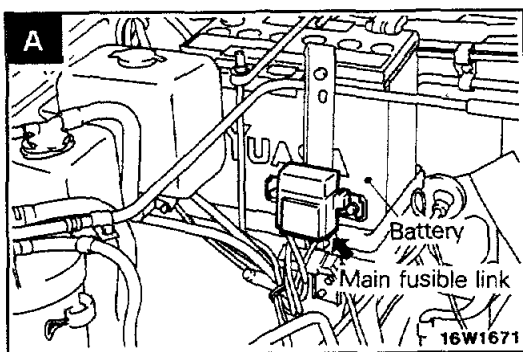
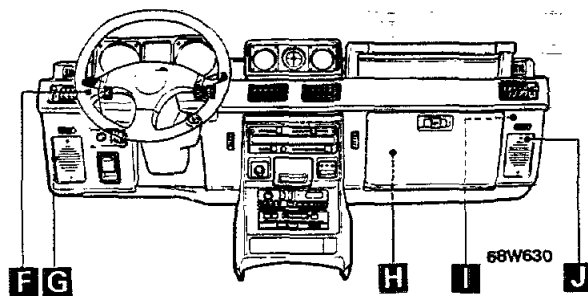
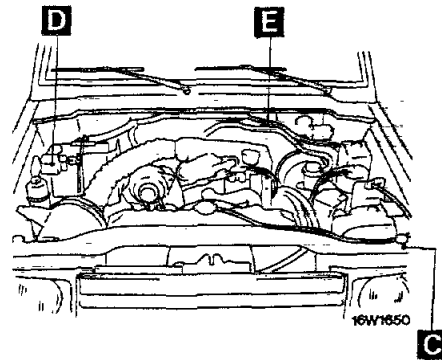
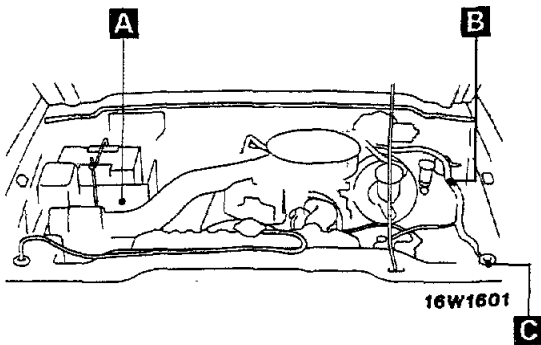

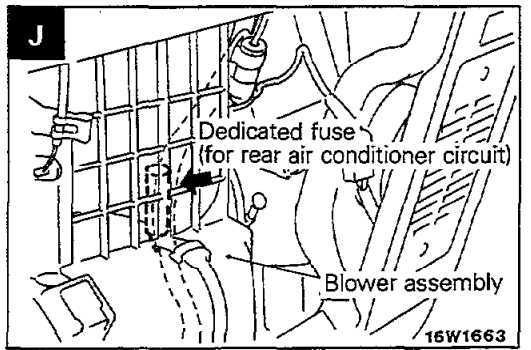
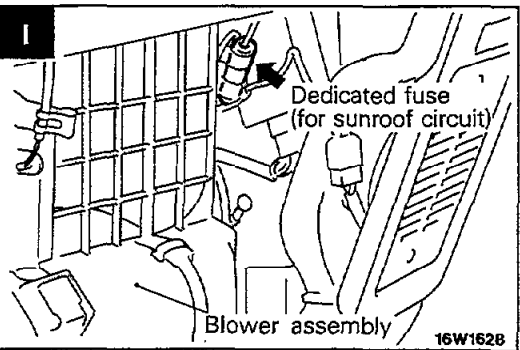
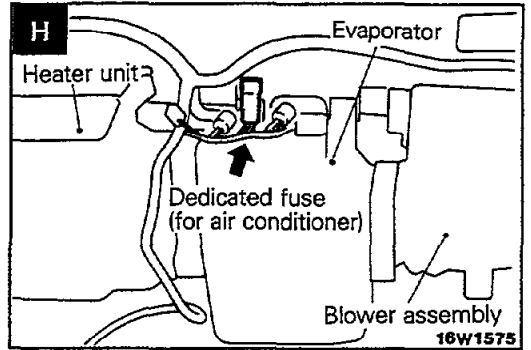
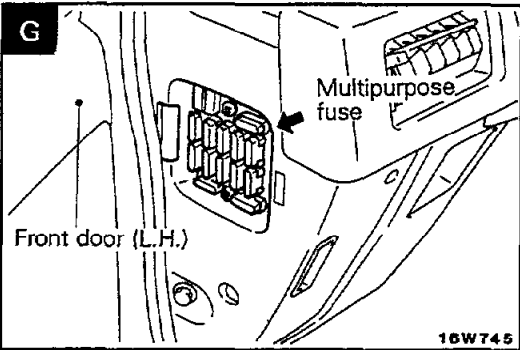
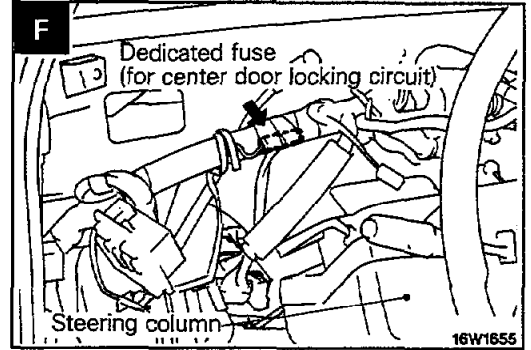
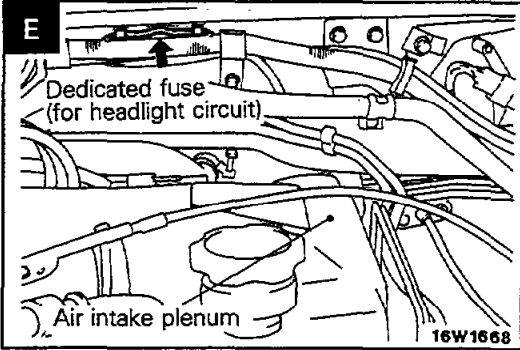
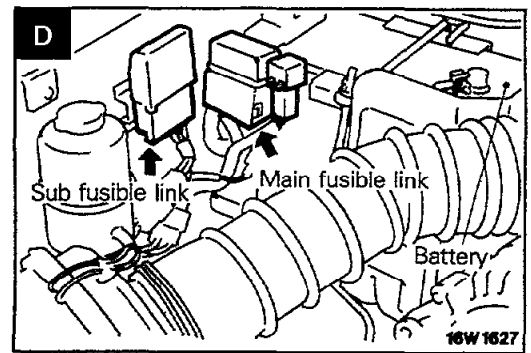
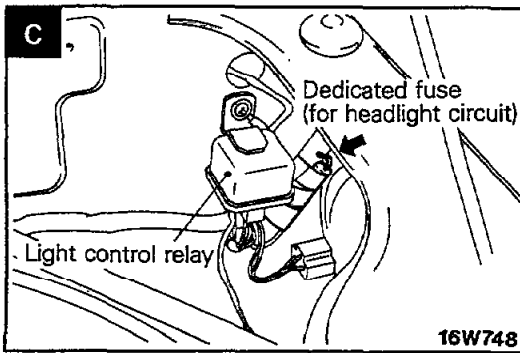

8-12 ELECTRICAL SYSTEM PARTS LOCATION – Grounding <2.6L Engine>

GROUNDING <2.6L Engine>

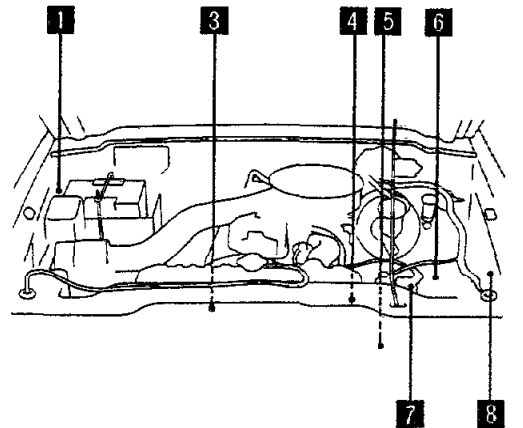

16W1601

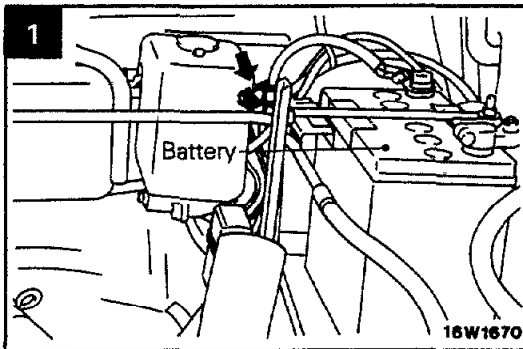

16W1670

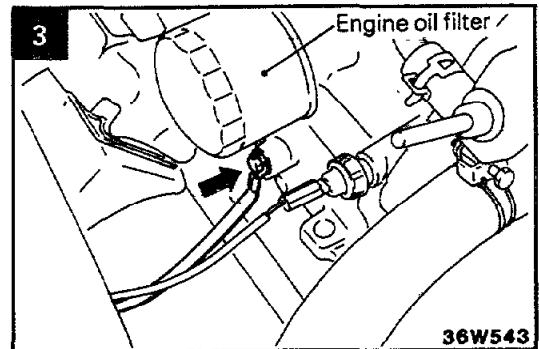

36W543

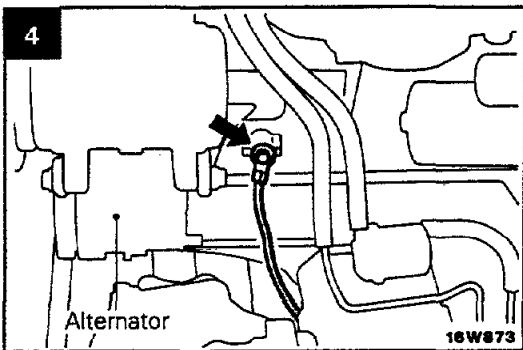

16W873

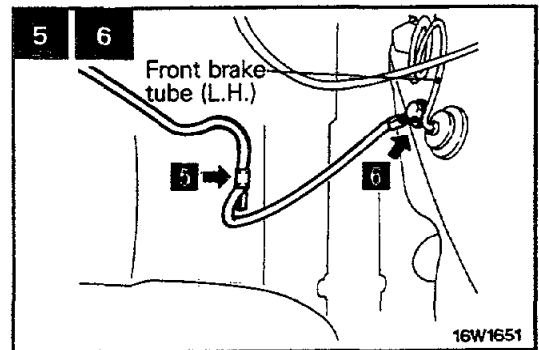

16W1651

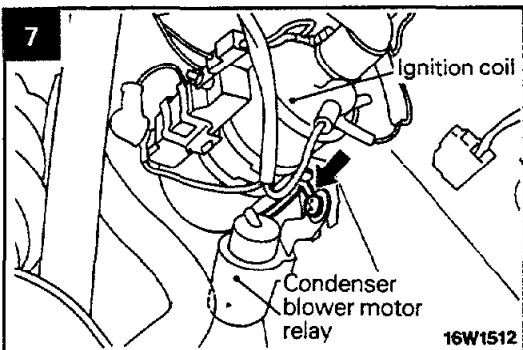

16W1512

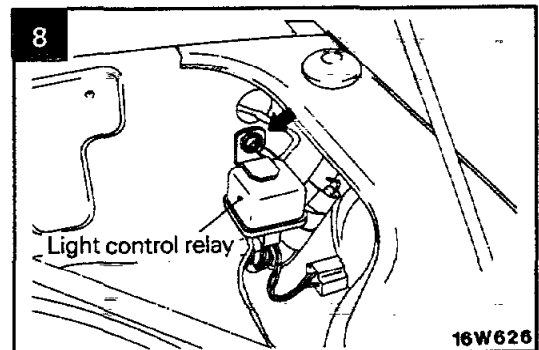

16W626

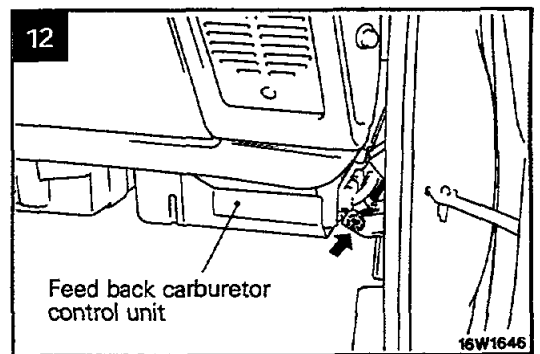
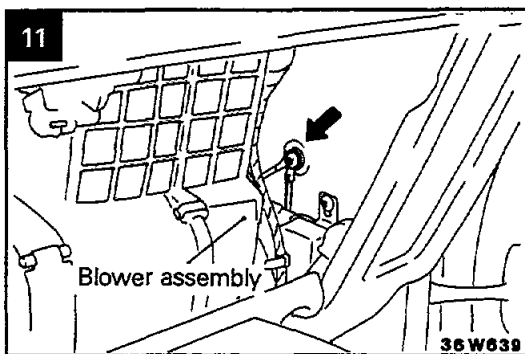
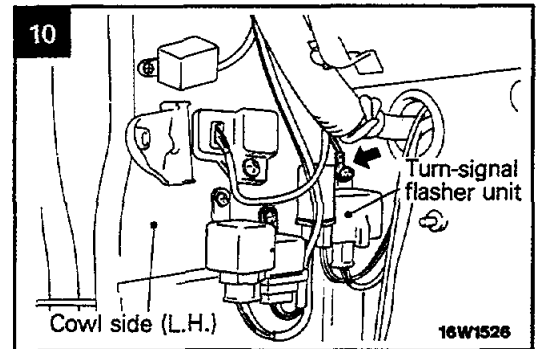
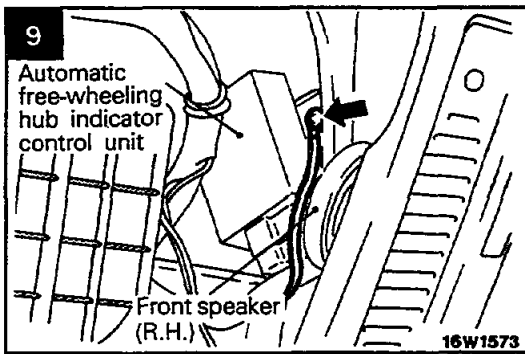
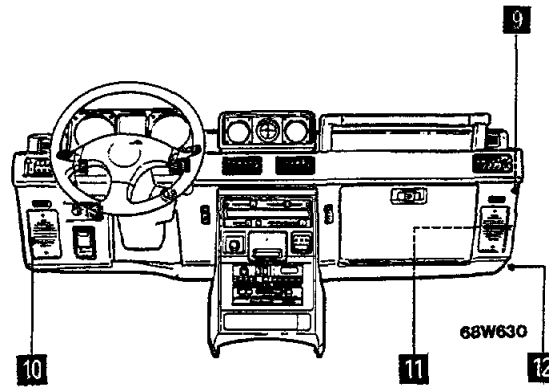

8-14 ELECTRICAL SYSTEM PARTS LOCATION – Grounding <3.0L Engine>

GROUNDING <3.0L Engine>

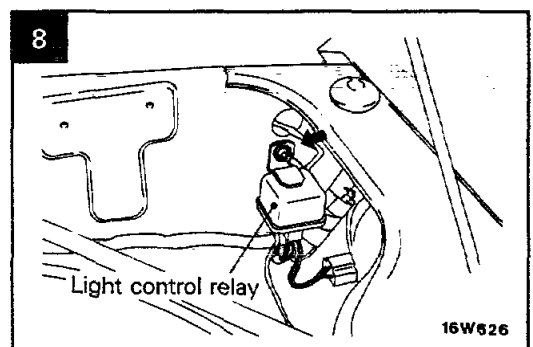
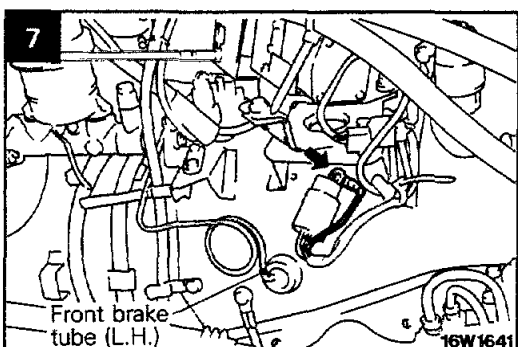
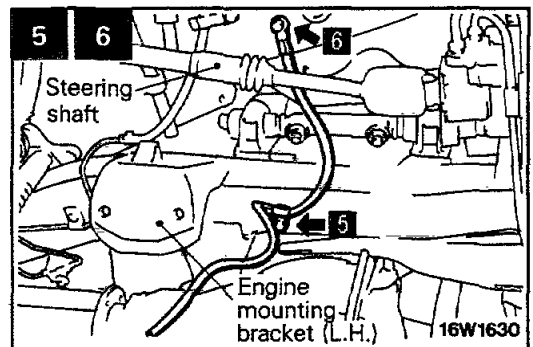
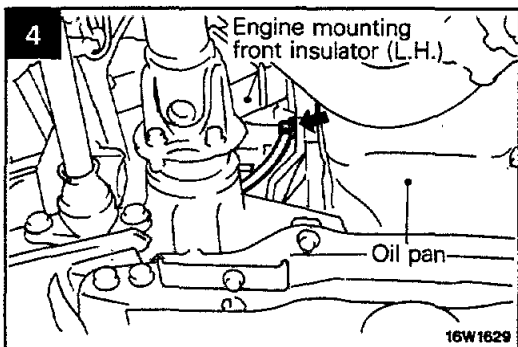
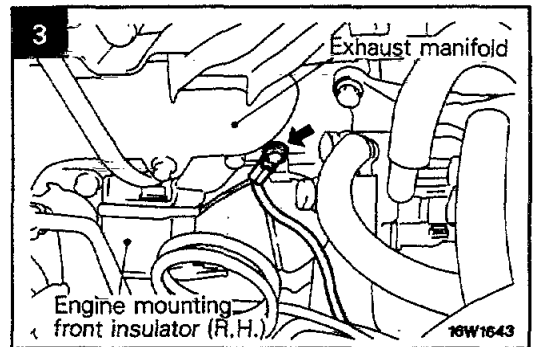
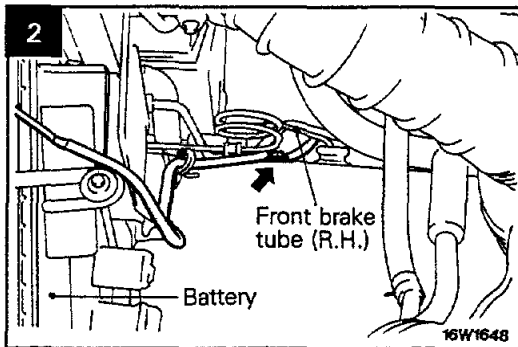
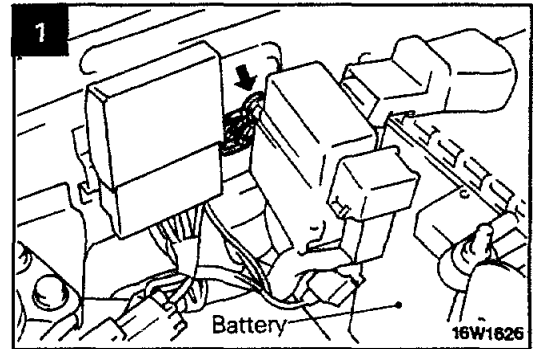
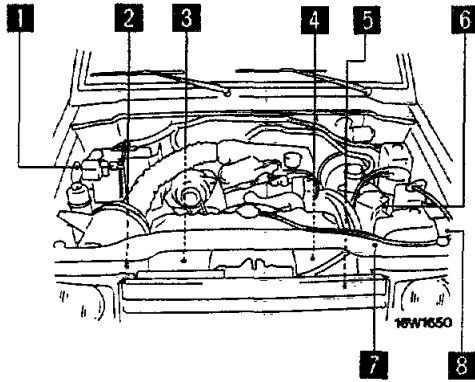

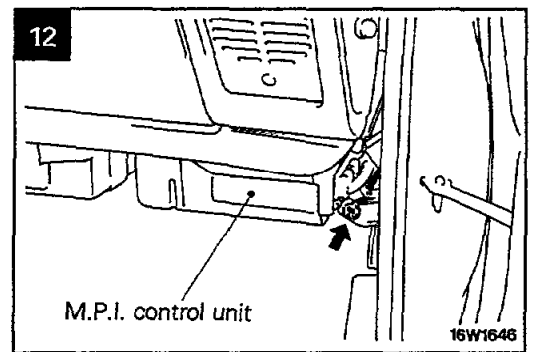
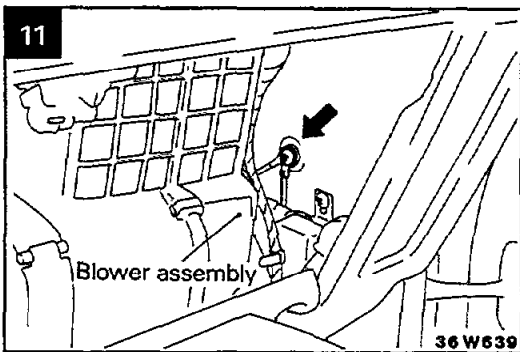
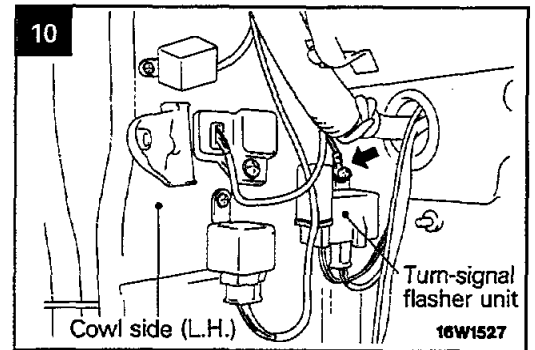
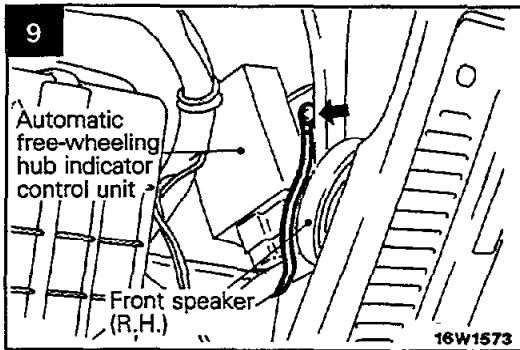
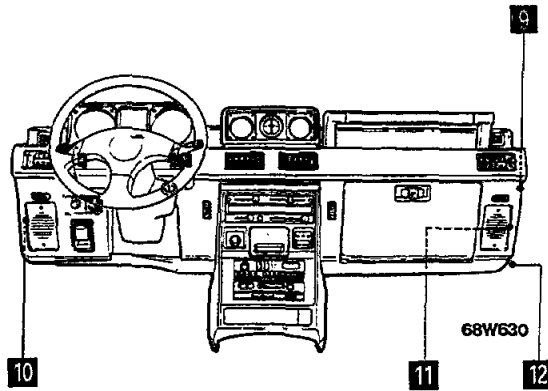

DIODE

Items	Symbol	Items	Symbol
Diode (for automatic transmission oil temperature warning light)	A	Diode (for maintenance required warning light)	B

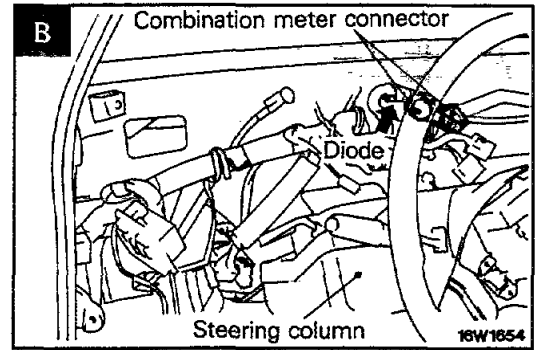
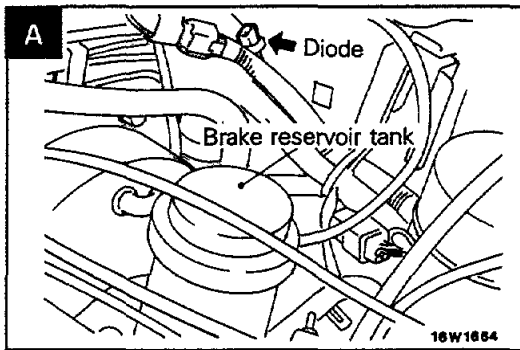
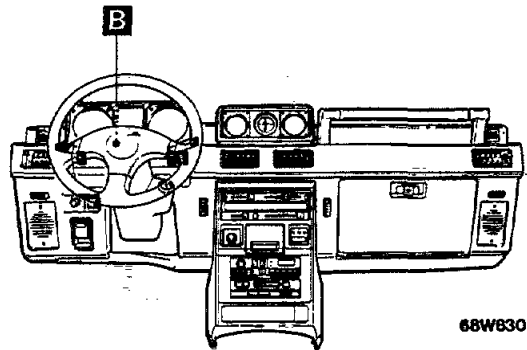
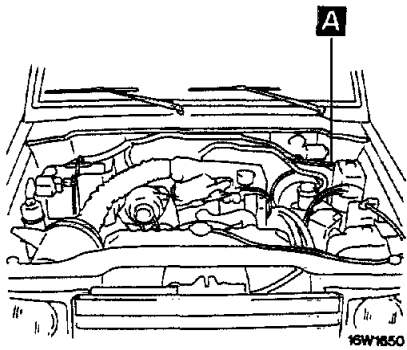

INSPECTION TERMINAL

Items	Symbol
Checker connector	C
Fuel pump drive terminal <3.0L Engine>	B
Self-diagnosis check connector	A
Spark timing adjuster connector	D

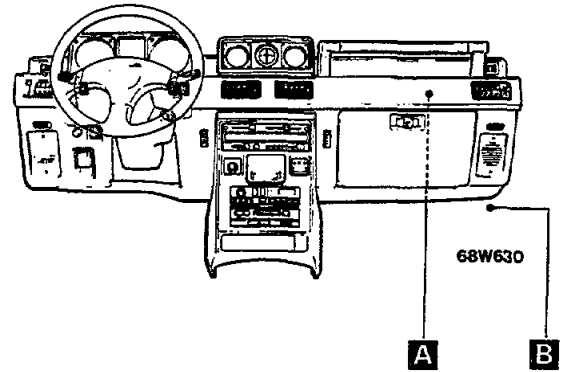

<2.6L Engine>

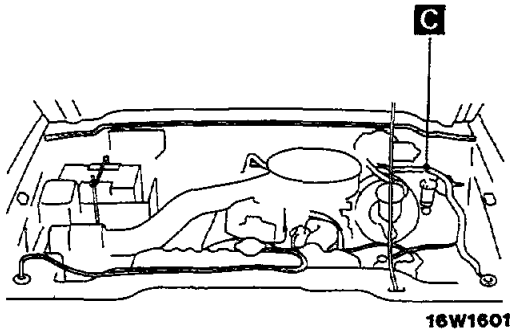

<3.0L Engine>

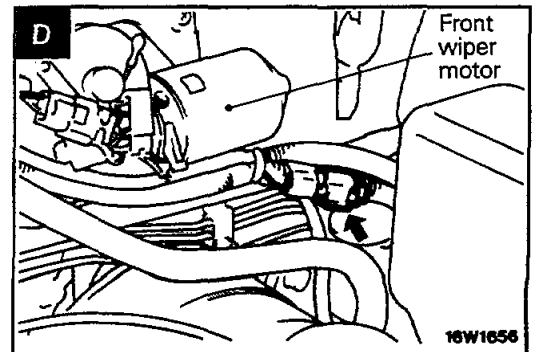
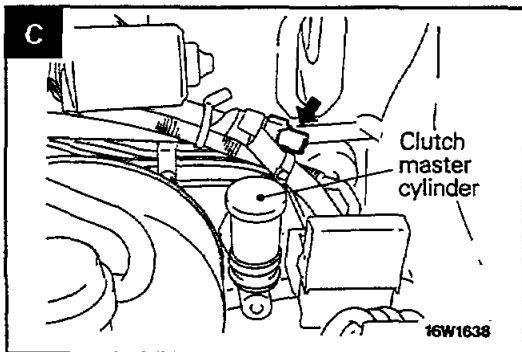
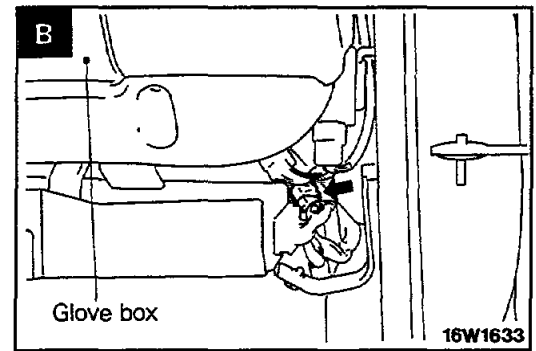
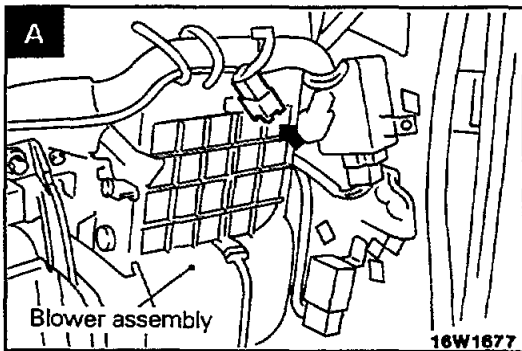
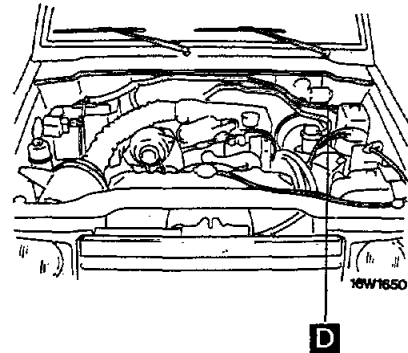

8-18 INSPECTION OF HARNESS CONNECTOR – Inspection of Harness Connector

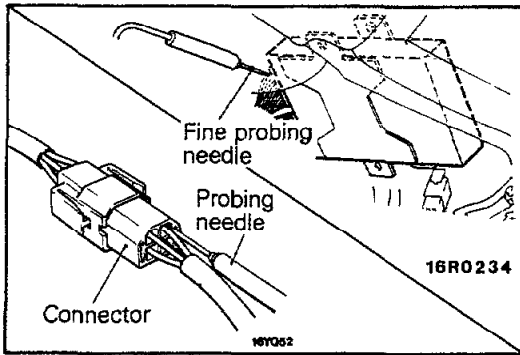

INSPECTION OF HARNESS CONNECTOR

N08CAAA

CONTINUITY AND VOLTAGE TEST FOR CONNECTOR

Following procedures shall be followed for testing continuity and voltage at connector in order to prevent improper contact and deterioration of waterproof in connector.

CONVENTIONAL (NON-WATERPROOF) CONNECTOR

Check shall be done by inserting a probing needle from harness side.

WATER PROOF CONNECTOR

Caution

Do not insert probing needle from harness side as it will deteriorates waterproof and cause for rusting. To inspect the energized circuit, use the ECI checker.

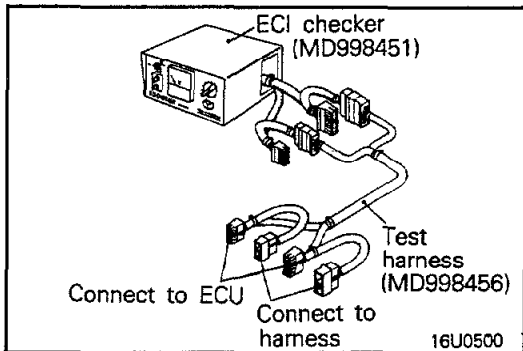

CHECK FOR IMPROPER ENGAGEMENT OF TERMINAL

When terminal stopper of connector is out of order, engagement of male and female terminals becomes improper even when connector itself is engaged perfectly and terminal sometimes slips out to rear side of connector. Ascertain, therefore, that each terminal does not come off connector by pulling each harness wire.

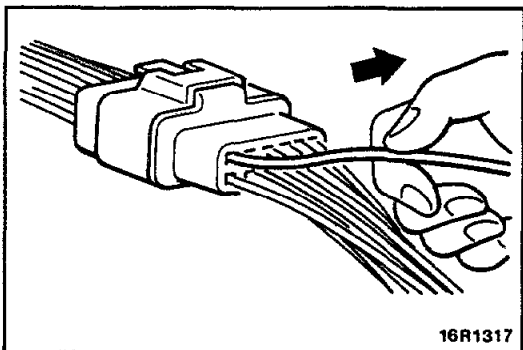

ENGAGING AND DISENGAGING OF CONNECTOR TERMINAL

Connector which gives loose engagement shall be rectified by removing female terminal from connector housing and raise its lance to establish securer engagement. Removal of connector housing and raise its lance to establish securer engagement. Removal of connector terminal used for ECI and ELC 4 A/T control circuit shall be done in the following manner.

COMPUTER CONNECTOR

- (1) Insert screwdriver [1.4 mm (.06 in.) width] as shown in the figure, disengage front holder and remove it.
- (2) Insert harness of terminal to be rectified deep into connector from harness side and hold it there.

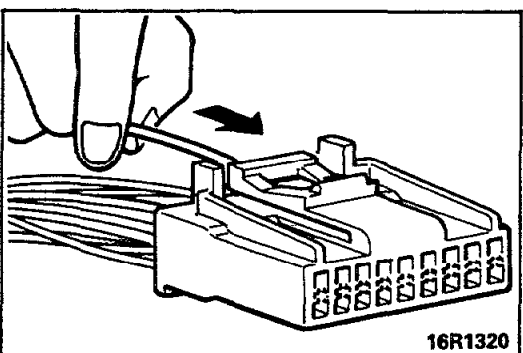
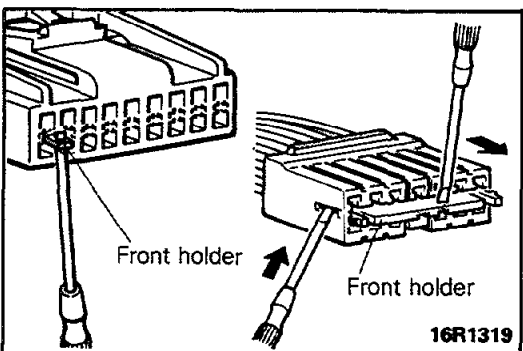

INSPECTION OF HARNESS CONNECTOR – Inspection of Harness Connector 8-19

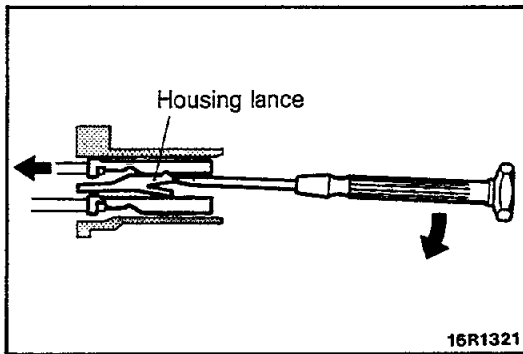

- (3) Insert tip of screwdriver [1.4 mm (.06 in.) width] into connector in a manner as shown in the figure, raise housing lance slightly with it and pull out harness.

NOTE

Tool No. 753787-1 supplied by AMP can be used instead of screwdriver.

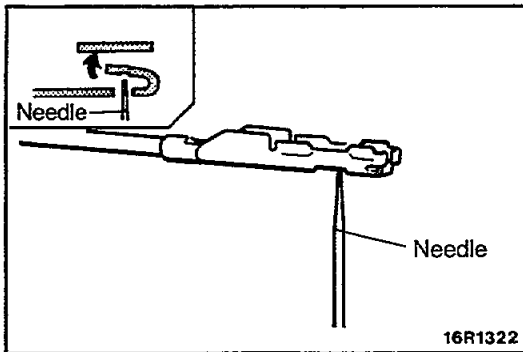

- (4) Insert needle through a hole provided on terminal and raise contact point of male terminal.

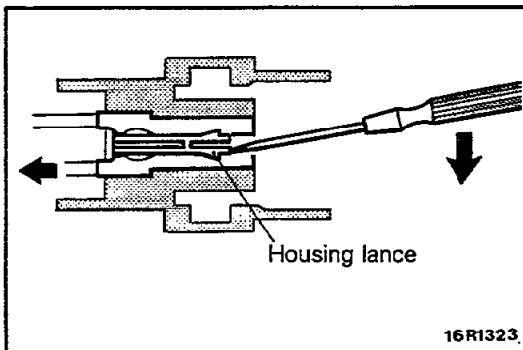

ROUND WATERPROOF CONNECTOR

- (1) Remove waterproof cap by using a screwdriver.
- (2) Insert tip of screwdriver [1.4 mm (.06 in.) or 2.0 mm (.08 in.) width] into connector in a manner as shown in the figure, raise housing lance slightly with it and pull out harness.

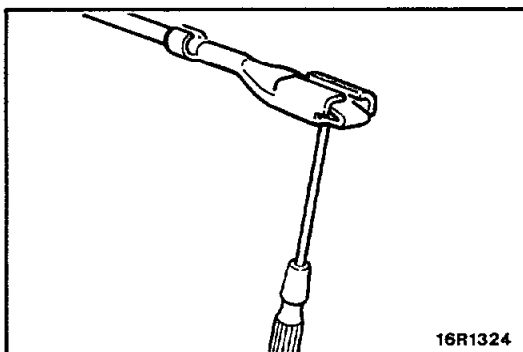

- (3) Insert screwdriver through a hole provided on terminal and raise contact point of male terminal.

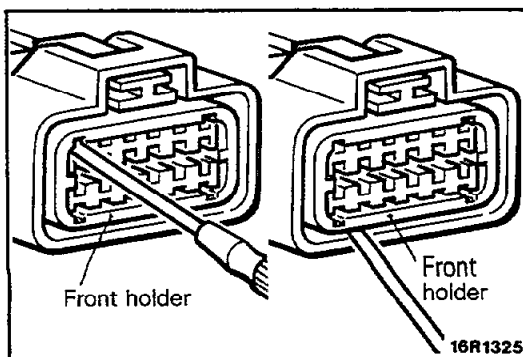

RECTANGULAR WATERPROOF CONNECTOR

- (1) Disengage front holder by using a screwdriver and remove it.

8-20 INSPECTION OF HARNESS CONNECTOR – Inspection of Harness Connector

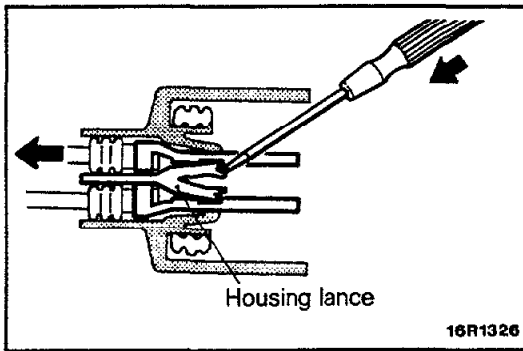

- (2) Insert tip of screwdriver [*0.8 mm (.03 in.) width] into connector in a manner as shown in the figure, push it lightly to raise housing lance and pull out harness.
*If right size screwdriver is not available, convert a conventional driver to suit the size.

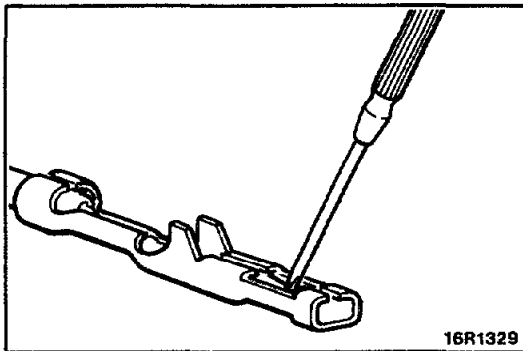

- (3) Press contact point of male terminal down by holding a screwdriver [1.4 mm (.06 in.) width] in a manner as shown in the figure.

INJECTOR CONNECTOR

- (1) Remove waterproof cap.

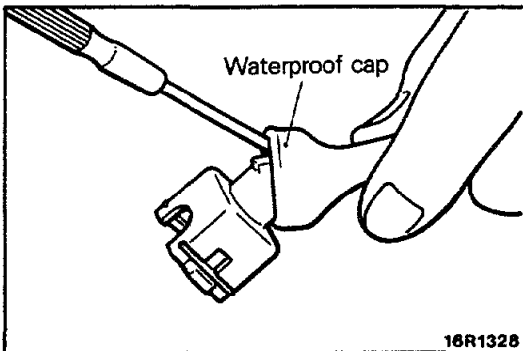

- (2) Insert tip of screwdriver [1.4 mm (.06 in.) width] into connector in a manner as shown in the figure, press in terminal lance and pull out harness.

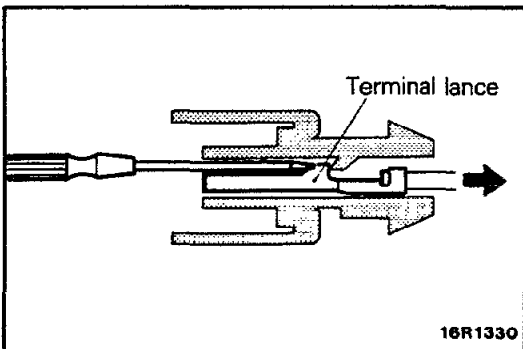

- (3) Press contact point of male terminal down by holding a screwdriver [1.4 mm (.06 in.) width] in a manner as shown in the figure.

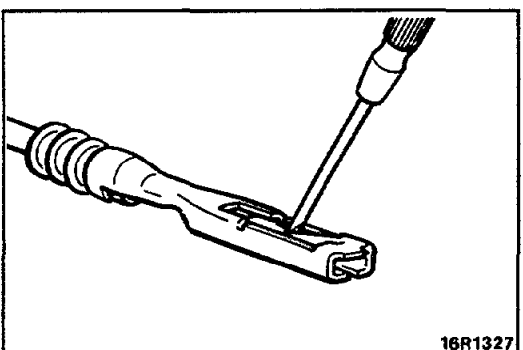

Caution

Correct lance to be in proper condition before terminal is inserted into connector.