

FUEL SYSTEM

CONTENTS

N14AA-

AUTO-CRUISE CONTROL SYSTEM	106	SPECIFICATIONS	2
AUTO-CRUISE CONTROL	134	General Specifications	2
SERVICE ADJUSTMENT PROCEDURES	125	Service Specifications	3
Accelerator Cables Inspection and Adjustment	127	Torque Specifications	4
Auto-cruise Control System Inspection	125	TROUBLESHOOTING	5
Individual Parts Inspection	128	Circuit Diagrams	9
SPECIAL TOOLS	106	Control Functions Table	8
SPECIFICATIONS	106	Fuel Tank and Fuel Line	7
General Specifications	106	MPI SYSTEM	54
Service Specifications	106	FUEL LINE AND VAPOR LINE	99
Torque Specification	106	FUEL TANK	96
TROUBLESHOOTING	107	INJECTOR	90
Auto-cruise Control Components Location	123	MPI SYSTEM INSPECTION	71
Auto-cruise Control Related Harnesses	122	Air Conditioner Switch	86
Check Chart	111	Air Conditioner Power Relay	89
Input Check	121	Components Location	71
Self-diagnosis Check	119	Control Relay	88
Troubleshooting Quick-reference Chart	107	EGR Control Solenoid Valve (M/T models only)	89
ENGINE CONTROL	102	EGR Temperature Sensor (California only)	86
ACCELERATOR CABLE AND PEDAL	104	Engine Coolant Temperature Sensor	84
SERVICE ADJUSTMENT PROCEDURES	102	Idle Position Switch	85
Accelerator Cable Free Play Adjustment	102	Idle Speed Control Servo (Stepper Motor)	87
SPECIFICATION	102	Inhibitor Switch	86
Service Specification	102	Injectors	86
Torque Specifications	102	Intake Air Temperature Sensor	84
TROUBLESHOOTING	102	Malfunction Indicator Light	74
FBC SYSTEM	2	Oxygen Sensor	86
CARBURETOR	34	Power Steering Oil Pressure Switch	86
FBC SYSTEM INSPECTION	25	Power Transistor	89
Components Location	25	Purge Control Solenoid Valve	89
Electric Choke Relay	33	Self-diagnosis	75
Engine Coolant Temperature Sensor	30	Throttle Position Sensor	85
Engine Speed Sensor	31	Vehicle Speed Sensor	86
Feedback Solenoid Valve	32	SERVICE ADJUSTMENT PROCEDURES	62
Oxygen Sensor	31	Basic Idle Speed Adjustment	63
Slow Cut Solenoid Valve	32	Curb Idle Speed Inspection	62
Throttle Opener Control Solenoid Valve for	32	EGR Valve Control Vacuum Check	70
Air Conditioner	32	Fixed SAS Adjustment	66
Throttle Position Sensor	30	Fuel Filter Replacement	67
Vacuum Switch	31	Fuel Gauge Unit Replacement	67
FUEL LINE AND VAPOR LINE	52	Fuel Pressure Measurement	68
FUEL PUMP	48	Fuel Pump Connector Disconnection	
FUEL TANK	50	(How to Reduce the Fuel Line Internal Pressure)	67
SERVICE ADJUSTMENT PROCEDURES	11	Fuel Pump Operation Check	68
Carburetor Appearance	11	Idle Position Switch and Throttle Position Sensor	
Carburetor Inspection	15	Adjustment	65
Dash Pot Adjustment	15	Overfill Limiter (Two-way Valve) Replacement	67
Fuel Filter Replacement	24	Purge Port Vacuum Check	70
Fuel Gauge Unit and Pipe Assembly Replacement	24	Throttle Body (Throttle Valve Area) Cleaning	65
Idle Speed Adjustment	11	SPECIAL TOOLS	56
Idle Speed and Mixture Adjustment	11	SPECIFICATIONS	54
Idle Speed Check Procedure	11	General Specifications	54
Overfill Limiter (Two-way Valve) Replacement	24	Service Specifications	55
Throttle Opener Adjustment for Air Conditioner	13	Torque Specifications	55
Throttle Position Sensor Adjustment	13	THROTTLE BODY	93
SPECIAL TOOLS	4	TROUBLESHOOTING	56
		Circuit Diagrams	60
		Control Functions	59
		Fuel Tank and Fuel Line	62

SPECIFICATIONS

GENERAL SPECIFICATIONS

N14CA-A

Items	Specifications
Fuel	
Fuel tank capacity lit. (gal.)	60 (15.9)
Fuel return system	Provided
Fuel filter	Cartridge type
Fuel pump	
Type	Mechanical diaphragm type
Drive by	Camshaft
Discharge pressure kPa (psi)	19.6-29.4 (2.8-4.2)-2500 rpm
Carburetor	
Type	Down-draft, 2-barrel feedback type
Choke type	Automatic (electric type)
Heater	PTC heater
Identification model No.	
for Federal/California	32-35 DIDEF-431
for California	32-35 DIDEF-441
Throttle bore-primary mm (in.)	32 (1.26)
secondary mm (in.)	35 (1.38)
Feedback solenoid valve	Duty cycle solenoid
Slow cut solenoid valve	Duty cycle solenoid
Throttle opener	Diaphragm type
Dash pot	Conventional type
Throttle position sensor	Variable resistor type
Bowl vent valve	Vacuum type
Mixture control valve	Vacuum type
Engine control unit	
Identification model No.	E2T55071
Input sensors	
Engine coolant temperature sensor	Thermistor type
Oxygen sensor	Zirconia sensor
Vacuum switch	Control-type switch
Output actuators	
Secondary air control solenoid valve	ON-OFF Solenoid valve
Throttle opener control solenoid valve	ON-OFF Solenoid valve

SERVICE SPECIFICATIONS

N14CB-A

Items	Specifications
Standard value	
Engine adjustments	
Basic ignition timing	7° ± 2° BTDC at curb idle
Actual ignition timing at high altitude-Federal/California and high altitude vehicles for Federal	Approx. 12° BTDC
Curb idle speed rpm	
For the first 500 km (300 miles)	725 ⁺¹⁵⁰ ₋₁₀₀
After 500 km (300 miles)	800 ± 100
Throttle opener adjustment	
Rpm for air conditioner load rpm (when air conditioner ON)	900–950
Dash pot touch rpm rpm	2000
Throttle-position sensor	
Adjustment voltage (throttle valve completely closed) V	0.250
Carburetor	
Main jet – primary	# 107.5
secondary	# 190
Pilot jet – primary	# 55
secondary	# 70
Enrichment jet	# 65
Automatic choke heater	Continuity-approx. 6 Ω [at 20°C (68°F)]
Choke breaker opening mm (in.)	
1st stage	2.3–2.5 (.091–0.98)
2nd stage	3.0–3.2 (.118–.126)
First idle rpm	Approx. 2,350
Feedback solenoid valve coil resistance Ω	54–66 [at 20°C (68°F)]
Slow cut-off solenoid valve coil resistance Ω	48–60 [at 20°C (68°F)]
Throttle-position sensor resistance kΩ	3.5–6.5
Input sensor	
Engine coolant temperature sensor resistance kΩ	
20°C (68°F)	2.5
80°C (176°F)	0.3
Oxygen sensor output voltage V	Approx. 1
Vacuum switch	ON more than 40 kPa (5.8 psi) OFF less than 26 kPa (3.9 psi)
Output actuator	
Secondary air solenoid valve resistance Ω	36–44 [at 20°C (68°F)]
Throttle opener control solenoid valve resistance Ω	40–48 [at 20°C (68°F)]

TORQUE SPECIFICATIONS

N14CC-A

Items	Nm	ft.lbs.
Carburetor installation bolt	15-20	11-14
Engine coolant temperature sensor	20-40	14-29
Oxygen sensor	40-50	29-36
Throttle-position sensor installation screw	2.5-4.5	1.8-3.2
Thermo valve (2 nipples)	20-35	14-25
Drain plug	15-20	11-14
Fuel tank to body	25-30	18-22
Fuel gauge unit	1	7
Air cleaner to rocker cover	16-19	12-14



SEALANTS

N14CE-A

Items	Specified sealant and adhesive	Quantity
Thermo valve threads	3M Adhesive Nut Locking No.4171 or equivalent	As required
Engine coolant temperature sensor threads	3M Adhesive Nut Locking No.4171 or equivalent	As required

SPECIAL TOOLS

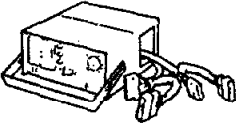
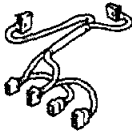
N14DA-A

Tool	Number	Name	Use
	MD998406	ECI checker	Diagnosis and inspection for FBC system
	MD998438	Test harness for FBC	Inspection for FBC system Use with MD998406
	MD998474	Test harness (8-pin, square)	Adjustment of throttle position sensor

TROUBLESHOOTING

When checking and correcting engine troubles, it is important to start with inspection of the basic systems. In case you have such troubles as (1) engine start failure, (2) unstable idling or (3) poor acceleration, therefore, you should first check the following basic systems.

- (1) Power supply
 - Battery
 - Fusible link
 - Fuse
- (2) Body ground
- (3) Fuel supply
 - Fuel line
 - Fuel filter
 - Fuel pump

- (4) Ignition system
 - Spark plug
 - High-tension cable
 - Distributor
 - Ignition coil
- (5) Emission control system
 - PCV system
 - EGR system
 - Vacuum leak
- (6) Others
 - Ignition timing
 - Idle speed

Troubles with the FBC system are often caused by poor contact of harness connector. It is, therefore, important to check harness connector contact.

Symptom	Probable cause	Remedy
Engine will not start or start too hard (cranks OK)	Carburetor Choke valve remains open—cold engine	Clean choke bore and link
	Improper choke breaker operation	Check and adjust choke breaker
	Electric choke malfunction	Check electric choke body and choke valve operation
	Needle valve sticking or clogged	Repair and replace
	FBC system Engine coolant temperature sensor malfunction	Check by using checker (MD998406) (Check component and replace if faulty)
	Vacuum hose disconnected or damaged	Repair or replace
	Slow-cut solenoid valve malfunction	Check component
	Feedback solenoid valve malfunction	Check component
	Vacuum switch malfunction—cold engine	Check component
	Faulty Engine Control Unit	Replace
	Harness broken/short circuited or connector not connected securely	Repair or replace
Rough idle or engine stalls	Carburetor Choke valve malfunction	Clean choke bore and link
	Improper fast idle—cold engine	Adjust fast idle speed
	Improper idle adjustment	Adjust idle speed
	Electric choke malfunction	Check choke body and choke valve operation
	Primary pilot jet clogged	Clean up or replace
	Dash pot malfunction	Adjust
	FBC system Slow-cut solenoid valve malfunction	Check drive signal by using checker (MD998406) Check component

Symptom	Probable cause	Remedy
Rough idle or engine stalls	Engine coolant temperature sensor malfunction	Check by using checker (MD998406) (Check component and replace if faulty)
	Vacuum hose disconnected or damaged	Repair or replace
	Throttle position sensor malfunction	Check component and adjust
	Engine speed sensor malfunction	Check by using checker (MD998406) Check harnesses for continuity
	Throttle opener control system malfunction	Check system. If faulty, check components
	Harness broken/short-circuited or connector not connected securely	Repair or replace
Engine hesitates or poor acceleration	Carburetor Acceleration pump malfunction	Check pump discharge rate
	Choke valve remains open-cold engine	Clean choke bore and link
	Choke valve remains closed-hot engine	Check choke valve operation
	Enrichment valve faulty	Repair or replace
	Main jet clogged	Clean up
	Enrichment jet clogged	Clean up
	Secondary valve operation abnormal	Check valve operation
	Auxiliary acceleration pump malfunction -cold engine	Check pump discharge rate
	FBC system Feedback solenoid valve malfunction	Check drive signal by using checker (MD998406) Check component
	Vacuum switch malfunction	Check by using checker (MD998406) (Check component and replace if faulty)
	Engine coolant temperature sensor malfunction	Check by using checker (MD998406) (Check component and replace if faulty)
	Throttle position sensor malfunction	Check component and adjust
	Engine speed sensor malfunction	Check by using checker (MD998406) Check harnesses for continuity
	Harness broken/short-circuited or connector not connected properly	Repair or replace
Engine dieseling (runs after ignition switch is turned off)	Carburetor Engine idle speed too high	Adjust idle speed
	FBC system Slow cut solenoid valve malfunction	Check component
Poor fuel mileage	Carburetor Choke valve operation abnormal	Check valve operation
	Engine idle speed too high	Adjust idle speed
	Electric choke malfunction	Check choke body and valve operation

Symptom	Probable cause	Remedy
Poor fuel mileage	Enrichment valve kept open	Repair or replace
	Auxiliary acceleration pump is in operation–hot engine	Repair or replace
	FBC system Engine coolant temperature sensor malfunction	Check by using checker (MD998406) (Check component and replace if faulty)
	Oxygen sensor malfunction	Check by using checker (MD998406) (Check component and replace if faulty)
	Feedback solenoid valve malfunction	Check drive signal by using checker (MD998406) Check component
	Slow-cut solenoid valve malfunction	Check drive signal by using checker (MD998406) Check components
	Throttle position sensor malfunction	Check component and adjust
	Engine speed sensor malfunction	Check by using checker (MD998406) check harnesses for continuity
	Harness broken/short circuited or connector not connected properly	Repair or replace

FUEL TANK AND FUEL LINE

N14EAAA1

Symptom	Probable cause	Remedy
Engine malfunctions due to insufficient fuel supply	Bent or kinked fuel pipe or hose	Repair or replace
	Clogged fuel pipe or hose	Clean or replace
	Clogged fuel filter or in-tank fuel filter	Replace
	Water in fuel filter	Replace the fuel filter or clean the fuel tank and fuel line
	Dirty or rusted fuel tank interior	Clean or replace
	Malfunctioning fuel pump (Clogged filter in the pump)	Replace
Evaporative emission control system malfunctions (When tank cap is removed, pressure releasing noise is heard)	Misrouting of vapor line	Correct
	Disconnect vapor line piping joint	Correct
	Folded, bent, cracked or clogged vapor line	Replace
	Faulty fuel tank cap	Replace
	Malfunctioning overfill limiter (two-way valve)	Replace

CONTROL FUNCTIONS TABLE

Related components		Function	Air/fuel mixture ratio control (*FBC)	Throttle opener control	Electric choke relay control	Secondary air control
Input	Power supply (ignition switch interlock)		x	x	x	x
	Power supply (battery back-up)		x	x	x	x
	Engine coolant temperature sensor		x		x	x
	Throttle-position sensor		x			
	Engine-speed sensor		x	x	x	x
	Oxygen sensor		x			
	Vacuum switch		x			x
	Air conditioner switch			* x		
Output	Feedback solenoid valve		x			
	Slow-cut solenoid valve		x			
	Throttle opener control solenoid valve (for air conditioner load)			x		
	Electric choke relay				x	
	Secondary air control solenoid valve					x

NOTE

The * symbol indicates no direct relation to the control unit's control functions.

CIRCUIT DIAGRAMS

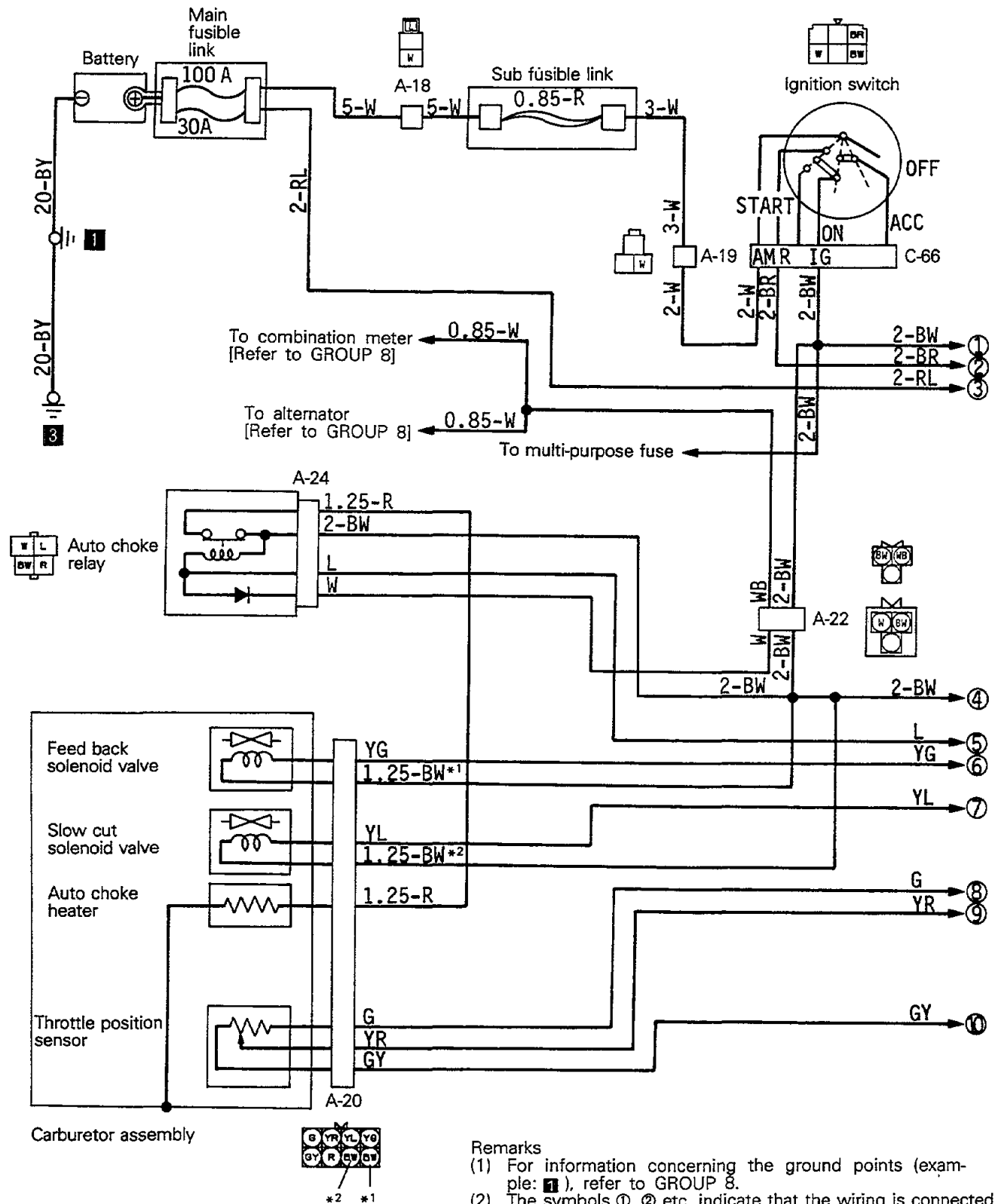

- Remarks
- (1) For information concerning the ground points (example: ①), refer to GROUP 8.
 - (2) The symbols ①, ② etc. indicate that the wiring is connected (using the same numerical symbol) to the following.

Color code for wiring

B : Black	Br : Brown	G : Green	Gr : Gray	L : Blue	Lg : Light green
LI : Light blue	O : Orange	P : Pink	R : Red	Y : Yellow	W : White

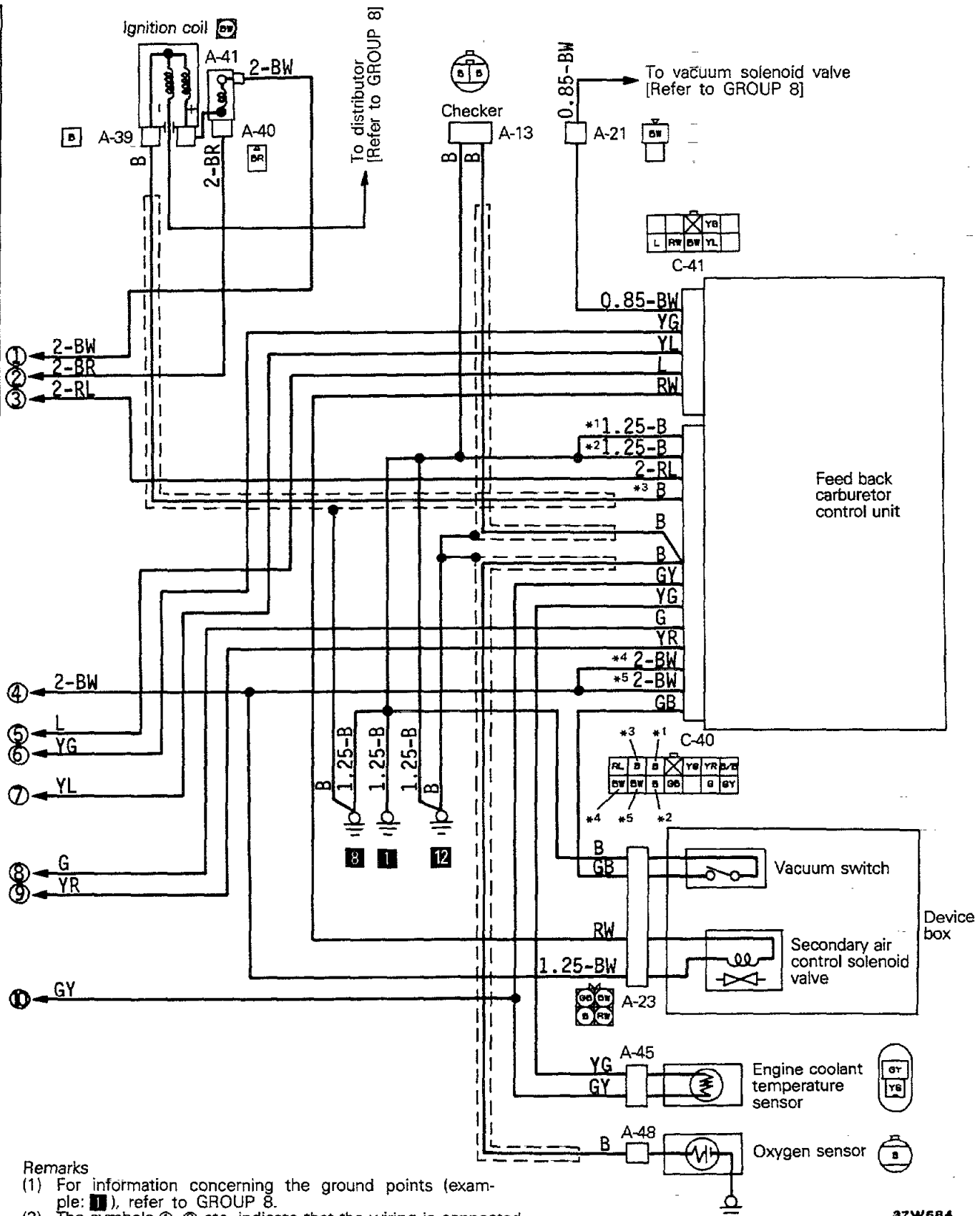

Remarks

- (1) For information concerning the ground points (example: ■), refer to GROUP 8.
- (2) The symbols ①, ② etc. indicate that the wiring is connected (using the same numerical symbol) to the previous page.

Color code for wiring

B : Black	Br : Brown	G : Green	Gr : Gray	L : Blue	Lg : Light green
LI : Light blue	O : Orange	P : Pink	R : Red	Y : Yellow	W : White

SERVICE ADJUSTMENT PROCEDURES

CARBURETOR APPEARANCE

N14FJ-

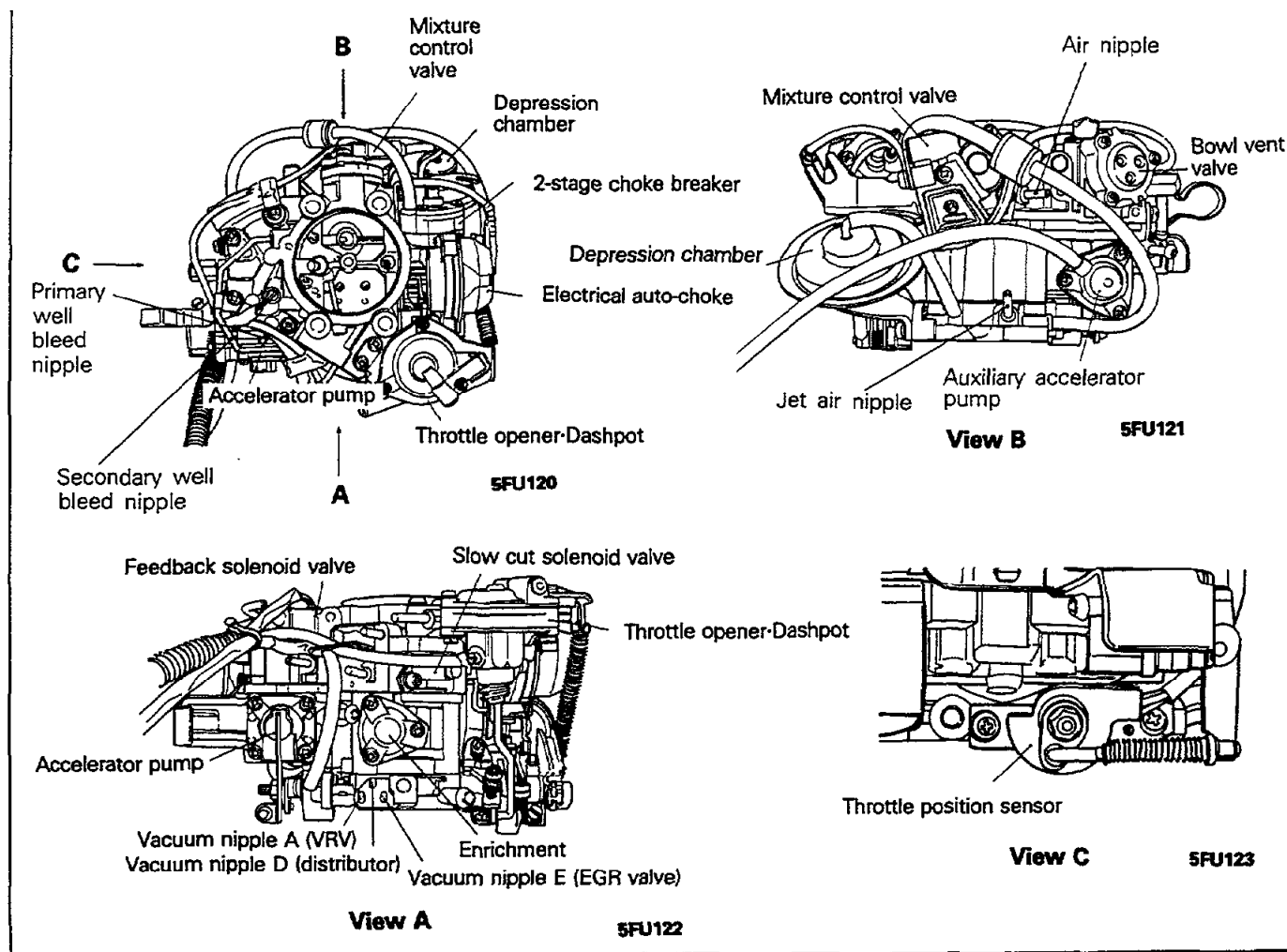

IDLE SPEED CHECK PROCEDURE

N14FHAAa

Refer to GROUP 0 – Checking and adjustment of the idling rpm

IDLE SPEED ADJUSTMENT

N14FHBAa

Refer to GROUP 0 – Idle Speed Inspection and Adjustment.

IDLE SPEED AND MIXTURE ADJUSTMENT (For Unscheduled Maintenance Only)

N14FHCF

- (1) Remove carburetor from engine (Refer to P.14-34.)
- (2) Clamp carburetor in a vice with idle mixture adjusting screw facing up (protect gasket surface from vice jaws.)
- (3) Drill a 2 mm (5/64 inch) pilot hole in the casting surrounding the idle mixture adjusting screw then redrill the hole to 3 mm (1/8 inch).
- (4) Insert a blunt punch into the hole and drive out plug.
- (5) Reinstall carburetor on engine.
- (6) Run the cold engine at fast idle until the cooling water temperature is raised to 85 to 95°C (185 to 205°F)

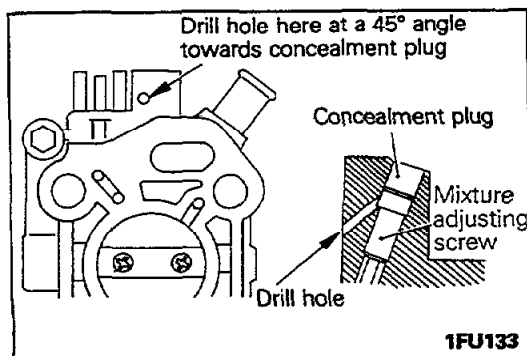

Inspection Conditions

- Engine coolant temperature: 85 – 95°C (185 – 205°F)
 - Light and accessory operation : off
 - Transmission : neutral
 - Steering wheel : center position (power steering equipped vehicles)
- (7) Prepare a timing light and tachometer.
 - (8) Depress accelerator pedal once to release the fast idle.
 - (9) Check the cycle of the timing light. Adjust if necessary.

Timing light cycle : 7°BTDC ± 2°

NOTE

Refer to GROUP 8 – Ignition System, for the timing cycle inspection and adjustment procedures.

- (10) Turn off the ignition key.
- (11) Disconnect the cable from the negative terminal of the battery for about 5 seconds. And then reconnect the cable to the original terminal.
- (12) Disconnect the connector of the exhaust oxygen sensor.
- (13) Run the engine for more than 5 seconds at the engine speed of 2,000 to 3,000 rpm.
- (14) Run the engine at idle for 2 minutes.
- (15) Set the CO-HC tester.

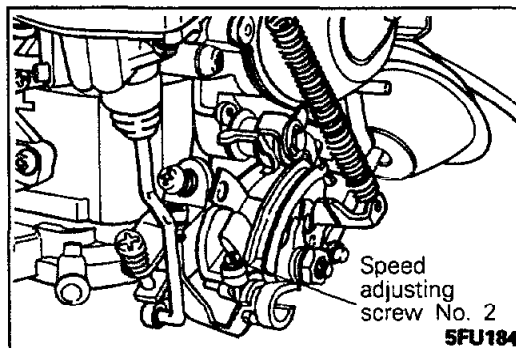
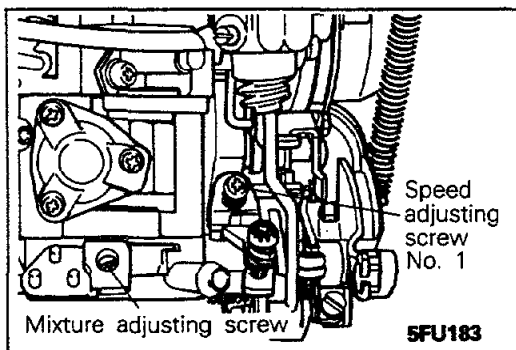
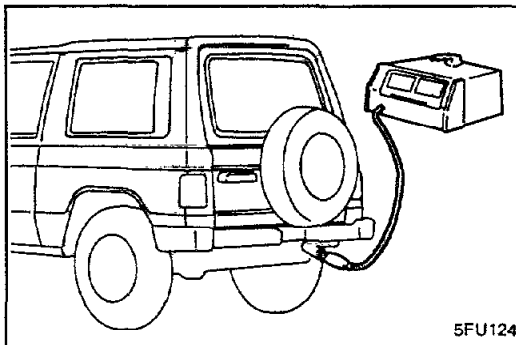

- (16) Set the idle CO and the engine speed to the specified value by adjusting the idle speed adjusting screw No. 1 and the idle mixture adjusting screw.

Idle CO : 0.1 to 0.3% at nominal curb idle speed
Curb idle speed :

$$*1725 \begin{matrix} + 150 \\ - 100 \end{matrix} \text{ rpm} / *2800 \pm 100 \text{ rpm}$$

NOTE

1. *1: For the first 500 km (300 miles)
2. *2: After 500 km (300 miles)
3. If the idle CO adjustment fails, suction of secondary air is likely. Plug the secondary air hose and try again.

Caution

DO NOT TOUCH the idle speed adjusting screw No. 2. The idle speed adjusting screw No. 2 is the preset screw that determines the relationship between the throttle valve and free lever, and has been accurately set at the factory. If this setting is disturbed, throttle opener adjustment and dash pot adjustment cannot be done accurately.

- (17) Turn off the ignition switch.
- (18) Connect the oxygen sensor connector.
- (19) Install the concealment plug into the hole to seal the idle mixture adjusting screw.

THROTTLE OPENER ADJUSTMENT FOR AIR CONDITIONER

N14FKBC

The throttle opener (idle-up actuator) described here controls the idle speed when the air conditioning is applied.

NOTE

Check the ignition timing and idle speed before performing this adjustment.

Inspection Conditions

- Engine coolant temperature : 85 – 95°C (185 – 205°F)
- Lights and accessories : Set to OFF
- Transmission : Neutral
- Steering wheel : Straightforward (vehicles with a power-steering)

- (1) Start the engine.
- (2) Set the tachometer.
- (3) Turn on the air conditioner switch.

NOTE

The solenoid valve will open and the intake manifold vacuum will act on the throttle opener to fully actuate it.

- (4) Check the engine speed during this operation.

Standard value : 900–950 rpm

If the engine speed is out of specification, adjust using the throttle opener (for air conditioner) adjusting screw.

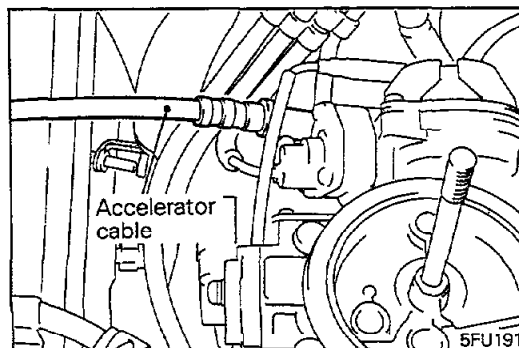
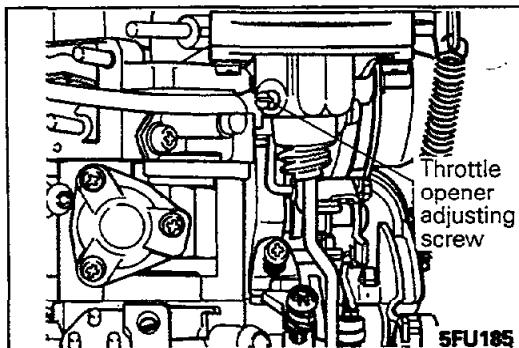

THROTTLE POSITION SENSOR ADJUSTMENT

N14FIBG

- (1) Loosen the accelerator cable enough.

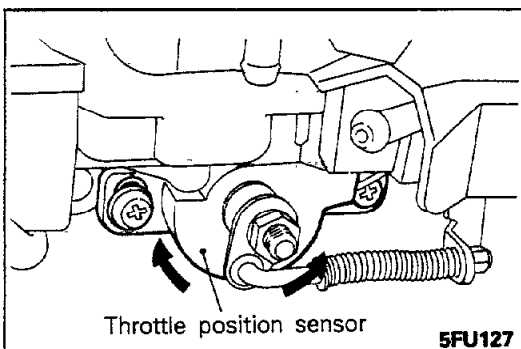
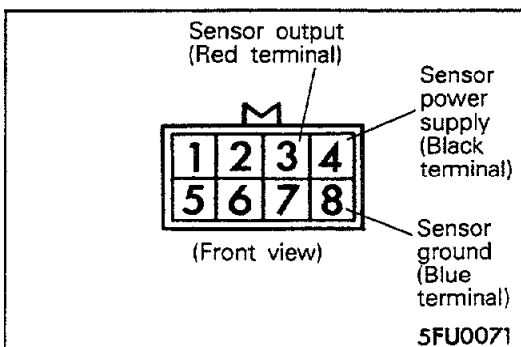
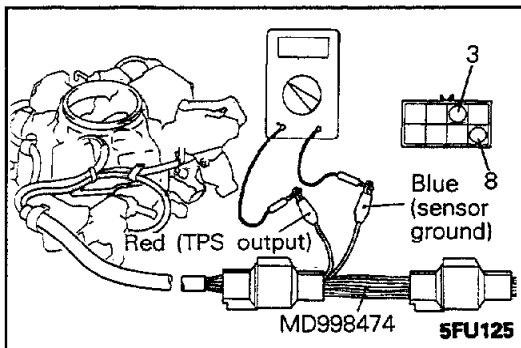
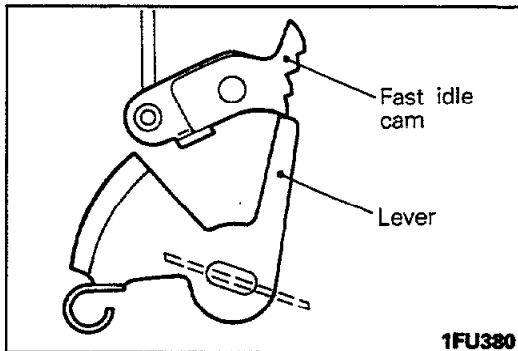
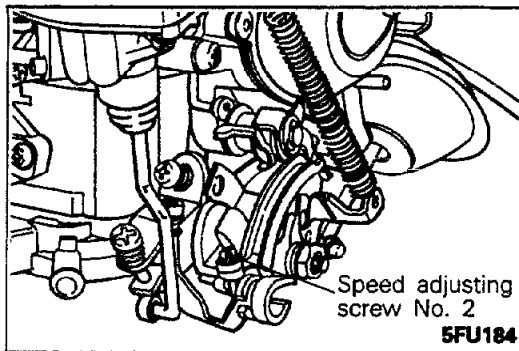

- (2) Loosen the speed adjusting screw No. 1 and No. 2 sufficiently to close the throttle valve completely. Record the number of turns loosened.

NOTE

1. Turning the screw counterclockwise closes the valve.

2. At this time, the fast idle control should have been released (the lever not resting on the fast idle cam).

- (3) Disconnect the carburetor connectors.

- (4) Connect the special tool (test harness) between the disconnected connectors.

- (5) Connect a voltmeter between terminal ③ (red: sensor output) and ④ (blue: sensor ground) of the carburetor's connectors.

Caution

Use a good, finely calibrated digital type voltmeter.

NOTE

Connection of FBC connector and special tool's terminal is as follows:

FBC connector	Special tool
Terminal ③ (sensor output) and Terminal Red	Terminal 3
Terminal ④ (sensor ground) and Terminal Blue	Terminal 8

- (6) Turn the ignition switch to ON (Don't start the engine).
- (7) Measure the voltage of the throttle position sensor output.

Standard value : 0.250 V

- (8) If it is out of specification, loosen the throttle position sensor attaching screw and adjust by turning the throttle position sensor to the standard value.

NOTE

Turning the throttle position sensor clockwise increase the output voltage.

- (9) Turn the ignition switch to OFF.
- (10) Tighten the SAS1 and SAS2 for the amount recorded in step (2). (Return to the original position.)
- (11) Remove the voltmeter and the special tool and connect the carburetor's connectors.

- (12) Adjust play of the accelerator cable. (See P.14-102).
- (13) Start the engine and check that the idle speed is as specified.

Standard value :
Curb idle speed

For the first 500 km (300 miles) : $725 \begin{matrix} +150 \\ -100 \end{matrix}$ rpm
After 500 km (300 miles) : 800 ± 100 rpm

DASH POT ADJUSTMENT

N14FMABa

NOTE

Curb idle speed adjustment must be properly adjusted before inspecting dashpot.

Inspection Conditions

Engine coolant temperature : 85 – 95°C (185 – 205°F)
 Lights and accessories : Set to OFF
 Transmission : Neutral
 Steering wheel : Straightforward (vehicles with a power steering)

- (1) Start the engine and run at idle.
- (2) Open the throttle valve for full stroke of the rod until the free lever contact SAS3.
- (3) Close the throttle valve until SAS2 contacts the free lever and check the engine speed at that moment.

Standard value : 2,000 rpm

- (4) If engine speed is not as specified, adjust dashpot RPM by turning SAS-3.
- (5) Release the free lever and verify that the engine returns to idle speed slowly.

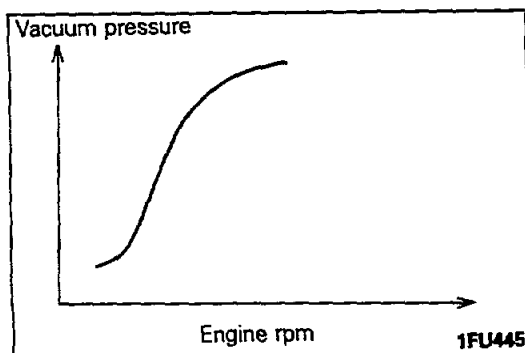
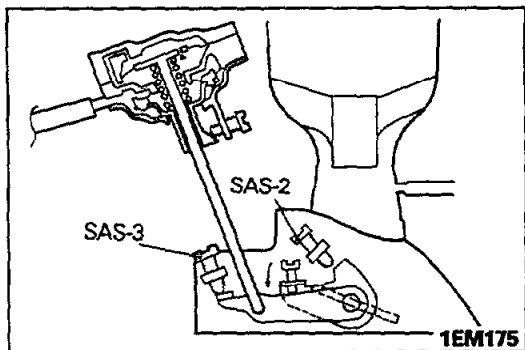
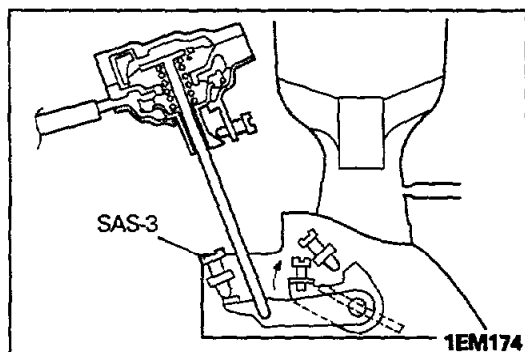
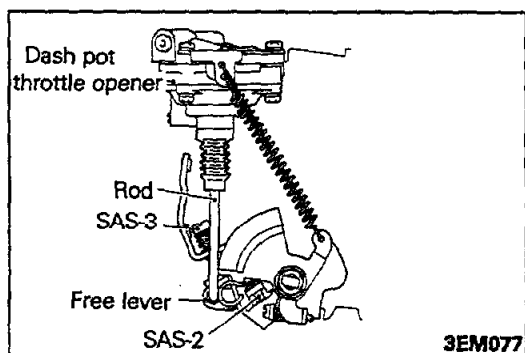

CARBURETOR INSPECTION

DISTRIBUTOR ADVANCE CONTROL VACUUM (D VACUUM)

N14FUAAa

Inspection Condition

Engine coolant temperature: 85 – 95°C (185 – 205°F)

- (1) Disconnect the vacuum hose from the carburetor D vacuum nipple and connect a hand vacuum pump to the nipple.

NOTE

For the location of the nipple, refer to the Carburetor Appearance (P.14-11.)

- (2) Start and race the engine to make sure that D vacuum increases with the engine speed.

NOTE

If abnormality is found in change of vacuum, blocked carburetor D port is suspected. Therefore, clean the port as necessary.

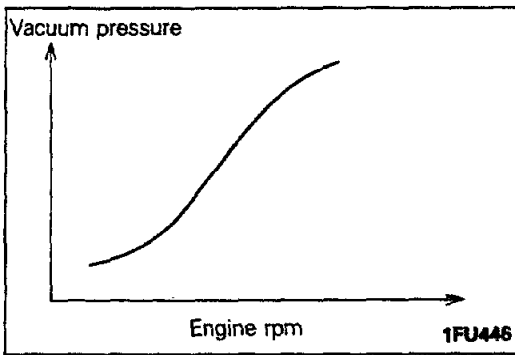
**EGR VALVE CONTROL VACUUM (E VACUUM)**

N14FVAAa

Inspection Condition

- Engine coolant temperature : 85 – 95°C (185 – 205°F)
- (1) Disconnect the vacuum hose from the carburetor E vacuum nipple and connect a hand vacuum pump to the nipple.

NOTE

For the location of the nipple, refer to Carburetor Appearance (P.14-11).

- (2) Start and race the engine to make sure that E vacuum increases with the engine speed.

NOTE

If abnormality is found in change of vacuum, blocked carburetor E port is suspected. Therefore, clean the port as necessary.

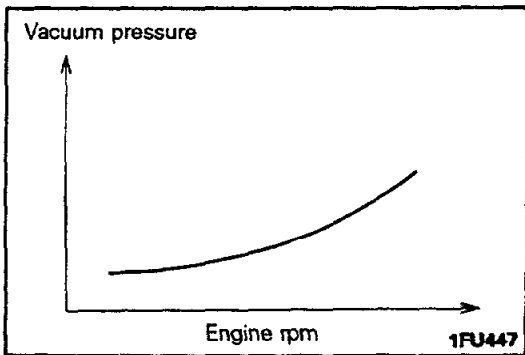
**VRV CONTROL VACUUM (A VACUUM)**

N14FLAAa

Inspection Condition

Engine coolant temperature : 85–95°C (185– 205°F)

- (1) Disconnect the vacuum hose from the carburetor A vacuum nipple and connect a hand vacuum pump to the nipple.

NOTE

For the location of the nipple, refer to Carburetor Appearance (P.14-11).

- (2) Start and race the engine to make sure that A vacuum increases gradually with the engine speed.

NOTE

If abnormality is found in change of vacuum, blocked carburetor A port is suspected. Therefore, clean the port as necessary.

VACUUM SWITCH CONTROL VACUUM (F VACUUM)

N14FWAAa

Inspection Condition

Engine coolant temperature : 85–95°C (185– 205°F)

- (1) Disconnect the vacuum hose from the carburetor vacuum nipple and connect a hand vacuum pump to the nipple.

NOTE

For the location of the nipple, refer to Carburetor Appearance (P.14-11).

- (2) Start and race the engine to make sure that F vacuum drops rapidly.

NOTE

If abnormality is found in change of the vacuum, blocked carburetor F port and vacuum passage. Therefore, disassemble and check the carburetor.

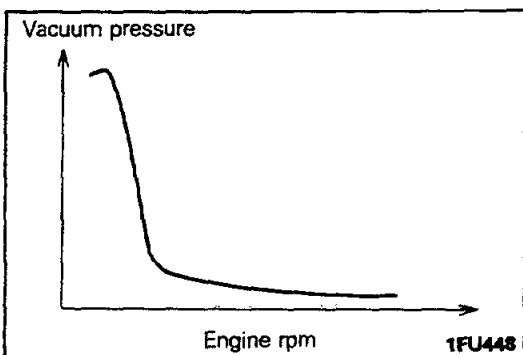

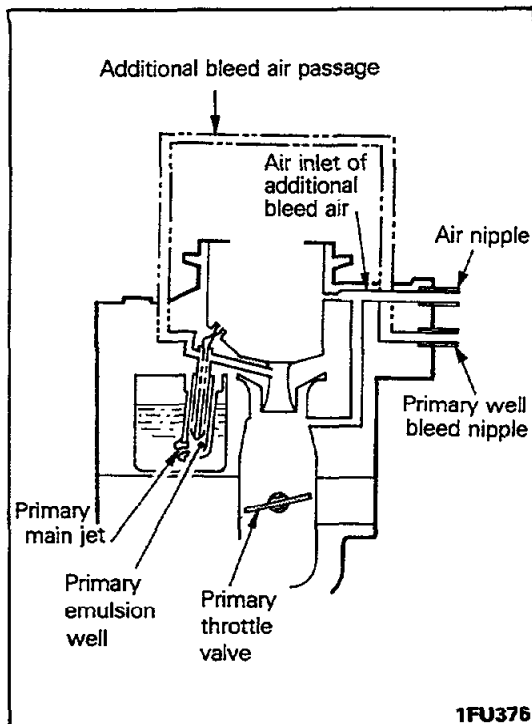

CARBURETOR BLEED AIR PASSAGE (CARBURETOR HIGH ALTITUDE COMPENSATION SYSTEM)
N14FRABa

PRIMARY WELL BLEED NIPPLE
Federal/California and High-altitude vehicles for Federal

NOTE
 For the nipple position, refer to Carburetor Appearance (P.14-11).

- (1) Disconnect the vacuum hoses from the air nipple and connect a hand vacuum pump to the nipple.
- (2) Apply vacuum to see that it leaks and does not build up inside the carburetor.
- (3) Disconnect the vacuum hose from the primary well bleed nipple and connect a hand vacuum pump.
- (4) Apply vacuum to see that it leaks and does not build up inside the carburetor.
- (5) If vacuum builds up, disassemble and check the carburetor. (Refer to P.14-35.)

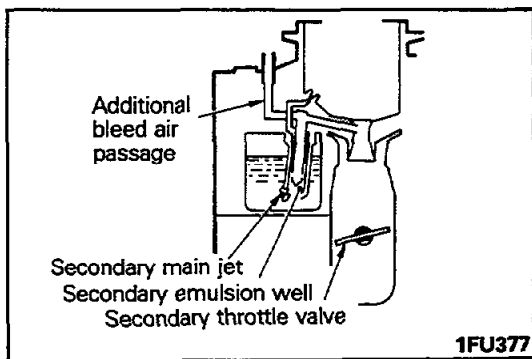

SECONDARY WELL BLEED NIPPLE
High-altitude vehicles for-Federal
N14FRBBa

NOTE
 For the nipple position, refer to Carburetor Appearance (P.14-11.)

- (1) Disconnect the vacuum hose from the bleed nipple and connect a hand vacuum pump to the nipple.
- (2) Apply vacuum to see that it leaks and does not build up inside carburetor.
- (3) If vacuum builds up, disassemble and check the carburetor. (Refer to P.14-35.)

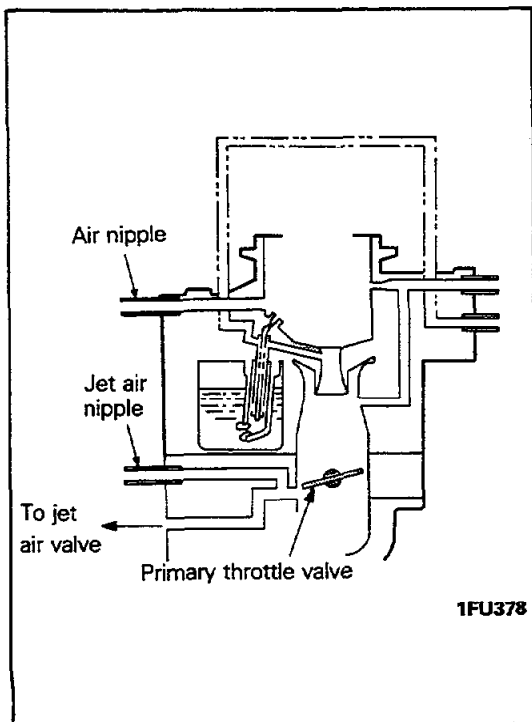

JET AIR NIPPLE
High-altitude vehicles for Federal
N14FRCAa

NOTE
 For the nipple position, refer to Carburetor Appearance (P.14-11.)

- (1) Disconnect the vacuum hoses from both air nipple and jet air nipple and connect a hand vacuum pump to the nipples.
- (2) Apply vacuum to see that it leaks and does not build up inside carburetor.
- (3) If vacuum builds up, disassemble and check the carburetor. (Refer to P.14-35.)

CARBURETOR SECONDARY VALVE OPERATION N14FOAAa

(1) Remove the air cleaner assembly.

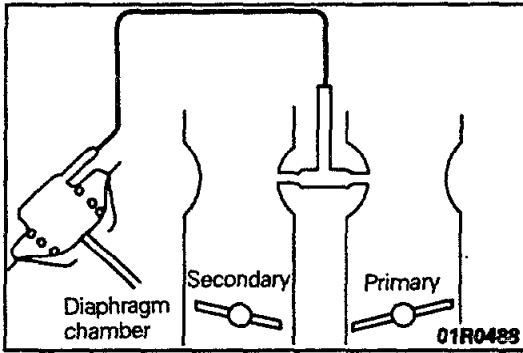

(2) Disconnect the secondary valve vacuum hose from the carburetor throttle body and connect a hand vacuum pump to the disconnected end of hose.

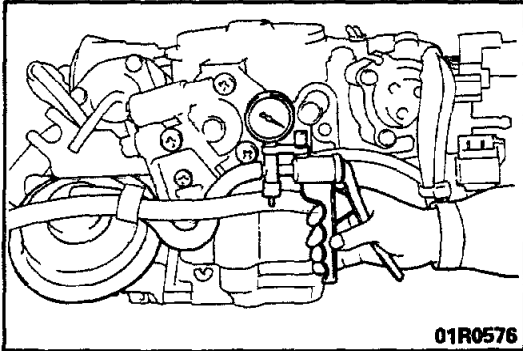

(3) With a vacuum of 13.3 kPa (1.9 psi) applied by the vacuum pump, fully open the primary throttle valve and check that the secondary throttle valve also opens fully.

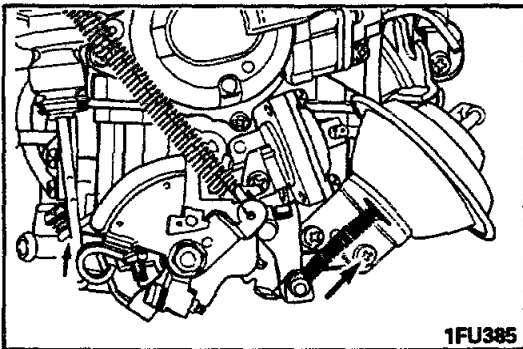

Vacuum is not held in depression chamber (vacuum leaks)	Replace depression chamber
Vacuum is held but secondary valve does not operate	Clean secondary throttle valve and related parts

CARBURETOR ACCELERATION PUMP

N14FPAAa

(1) Remove the air cleaner assembly cover.

(2) While opening the choke valve, open the throttle valve and check that fuel is injected from the pump nozzle. If fuel is not injected, clean the carburetor fuel passage.

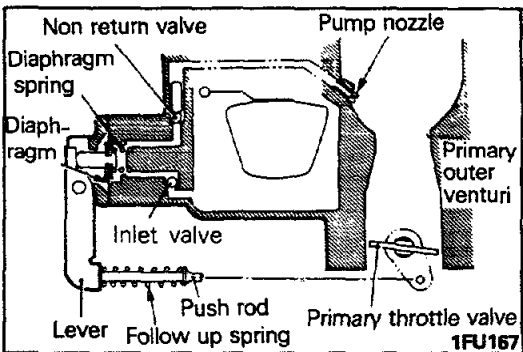

CHOKE VALVE

N14FQAAa

Refer to GROUP 0 – Maintenance Service.

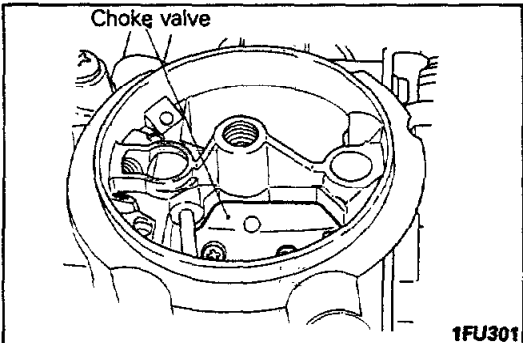

N14FQBC

ELECTRIC CHOKE

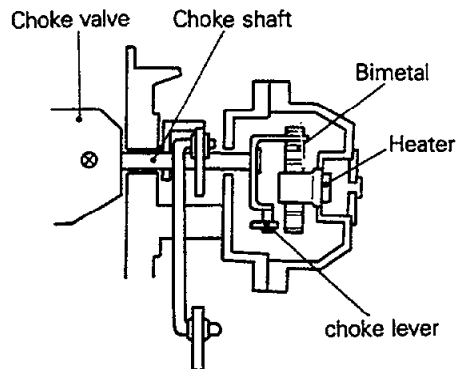
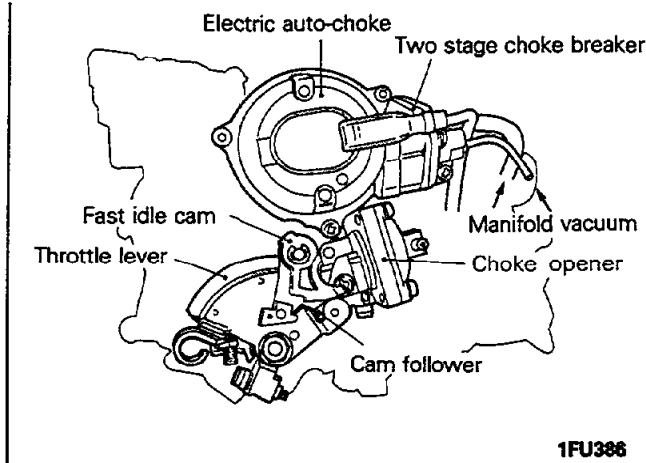

Caution

All carburetors have a tamper-proof choke. The choke-related parts are factory adjusted. The choke adjustment is not required during service, except when major carburetor overhaul or choke carburetor related parts adjustments are needed by state or local inspections.

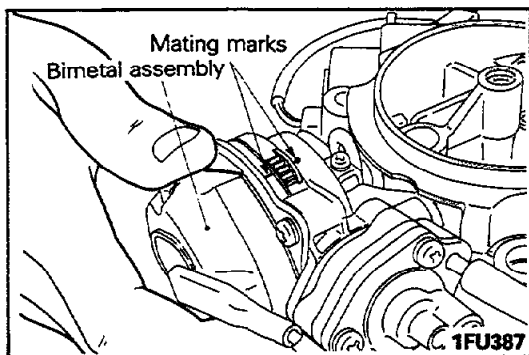

- (1) Check that the alignment marks on the electric choke and bimetal assembly are lined up. If not, align the marks.

NOTE

1. For removal of the bimetal assembly, refer to DISASSEMBLY AND REASSEMBLY (P.14-35). –for the Federal/California.
2. Misalignment and resultant symptom.

Misalignment	Symptom
Clockwise deviation	Better startability but plugs more likely to be sooty
Counterclockwise deviation	Poorer startability and more likely to stall

- (2) Check that engine coolant temperature is below 10°C (50°F).
- (3) Start the engine and check operation of the choke valve and fast idle cam, with hand on the electric choke body.

Electric choke body	Gets gradually hotter after engine start
Choke valve	Opens as bimetal temperature rises
Fast idle cam	Fast idle control is released as engine coolant temperature rises and fast idle breaker operates

- (4) If the electric choke body remains cool even after the engine is started, check the electric choke.

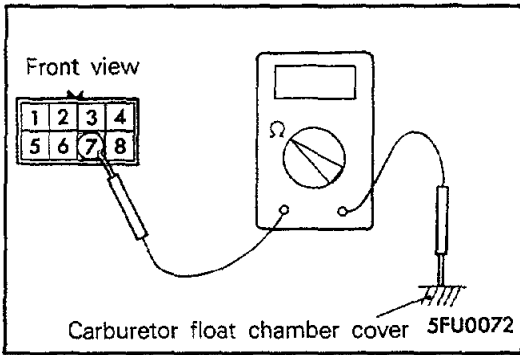

ELECTRIC CHOKE HEATER

N14FQCAb

- (1) Disconnect the carburetor connector and check continuity of the heater.

Normal state : Should be conductive [approx. 6 Ω at 20°C (68°F)]

- (2) If the heater is not conductive, replace the electric choke body (bimetal assembly).

NOTE

For replacement procedures, refer to DISASSEMBLY AND REASSEMBLY (P.14-35.)

CHOKE BREAKER SYSTEM

N14FQECb

At less than 18°C (65°F) (1st stage)

At 180°C (65°F) or higher (2nd stage)

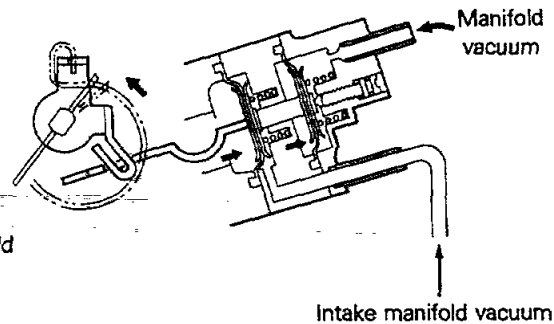
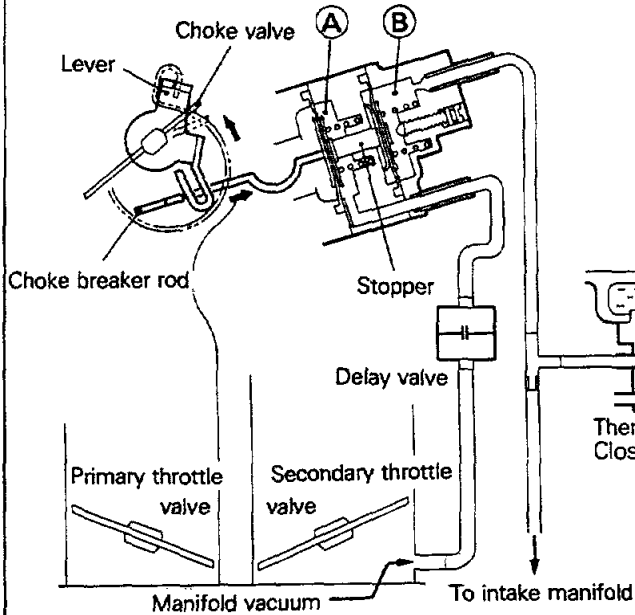

1FU391

1FU392

- (1) Remove the air cleaner.
- (2) Check conditions of the choke valve according to the procedures given in the table below.

NOTE

For information concerning the checking of the thermo valve, refer to GROUP 25 – Exhaust Gas Emission Control System.

Step	Engine coolant temperature	Check conditions	Choke valve when normal	Presumed cause when abnormal
1	10°C (50°F) or lower	Before starting engine	Fully closed	Malfunction of bimetal assembly Malfunction of link
2	10°C (50°F) or lower	Engine idling after start (Start after first fully depressing accelerator pedal one time.)	Slowly open slightly immediately after starting [Clearance: 2.3–2.5 mm (.091–.098 in.)]	Delay valve clogged Diaphragm damaged (chamber A)
3	10°C (50°F) or lower	Disconnect the vacuum hose (yellow stripe) from the choke breaker during idling.	No movement	Malfunction of thermo valve
4	25°C (77°F) or higher	Connect the vacuum hose (yellow stripe) and let the engine idle.	When the choke valve is lightly closed by a finger, stops at a position open more than step 2. [Clearance: approx. 3 mm (.12 in.)]	Malfunction of thermo valve Diaphragm damaged (chamber B)

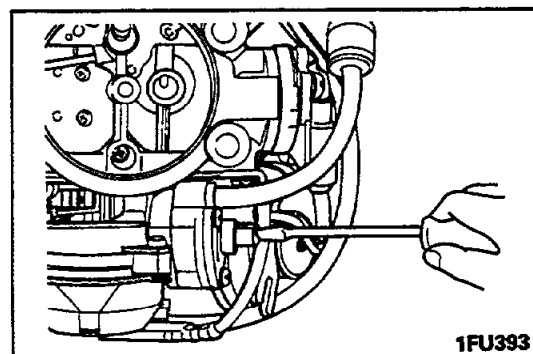
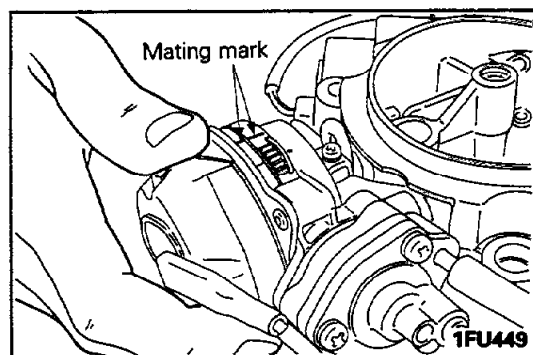
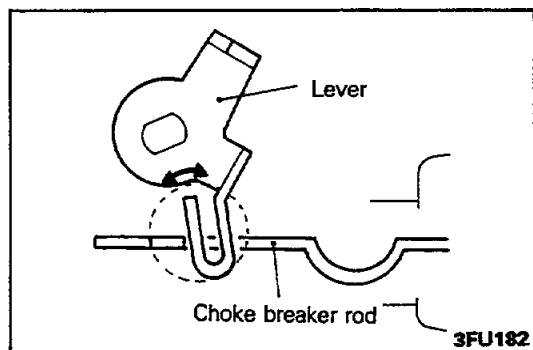
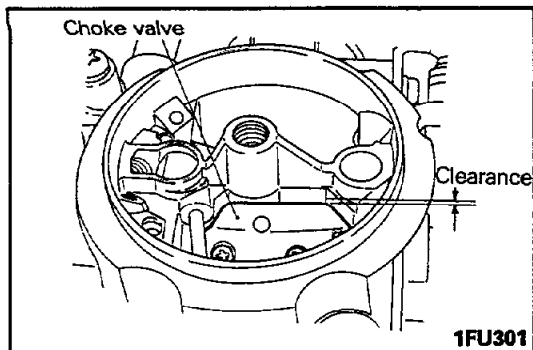

CHOKE BREAKER OPENING

N14FQFC6

- (1) After inspection of the choke breaker system, disconnect the vacuum hose (yellow stripe) from the choke breaker and make the following check.
- (2) With the engine idling, close the choke valve lightly with a finger until the choke valve stops. Then, measure the choke valve to choke bore clearance.

Standard value : 2.3–2.5 mm (.091–.098 in.)

- (3) If the clearance is not as specified, stop the engine, remove the bimetal assembly and adjust the rod end opening for standard clearance.

NOTE

For removal of the bimetal assembly, refer to DISASSEMBLY AND REASSEMBLY (P.14-35).

When removing the bimetal assembly, put a mark on the electric choke body.

NOTE

Rod end opening	Valve clearance	Expected result
Large	Large	Poorer startability and stall more likely
Small	Small	Plug likely to get sooty

- (4) Reconnect the removed yellow stripe vacuum hose and measure the choke valve to choke bore clearance as in step (2).

Standard value : 3.0–3.2 mm (.118–.126 in.)

- (5) If the clearance is out of specification, adjust by the adjusting screw.

NOTE

Adjusting screw turning direction	Valve clearance	Expected result
Clockwise	Small	Better startability but plug more likely to get sooty
Counter clockwise	Large	Poor startability and stall more likely

FAST IDLE

N14FOGC

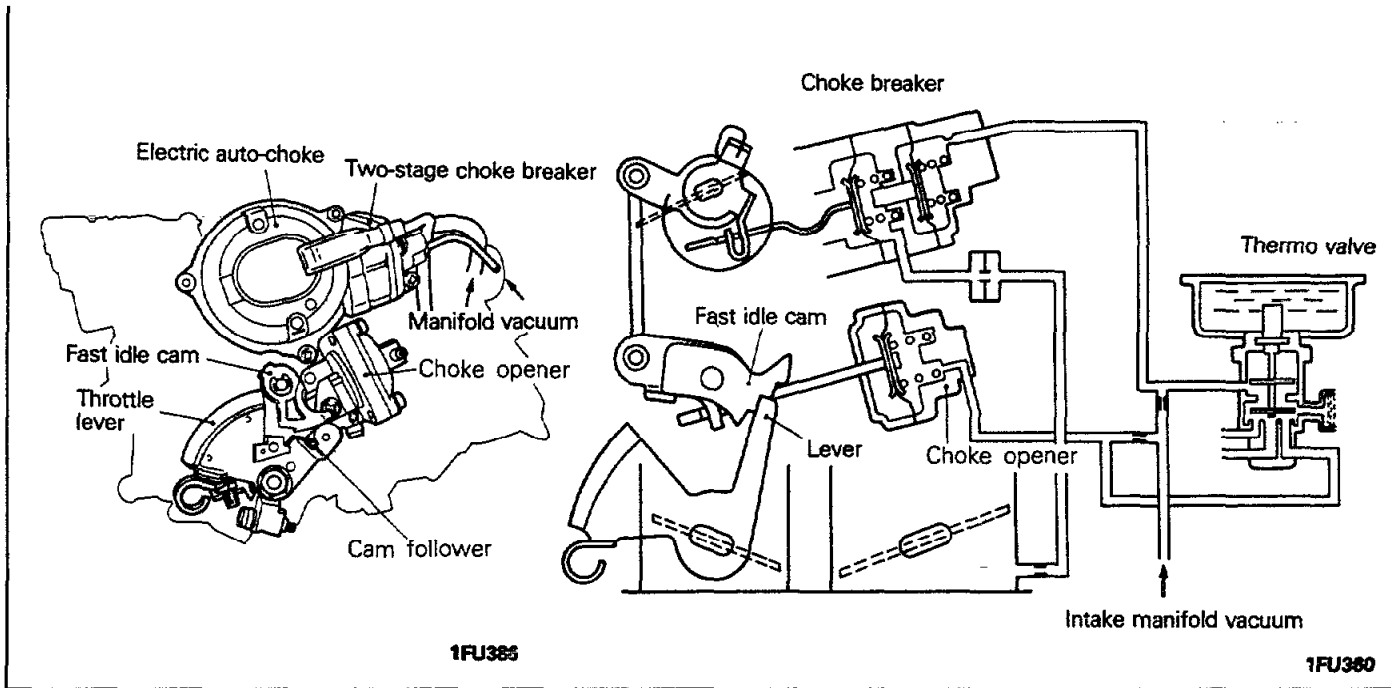

1FU385

1FU386

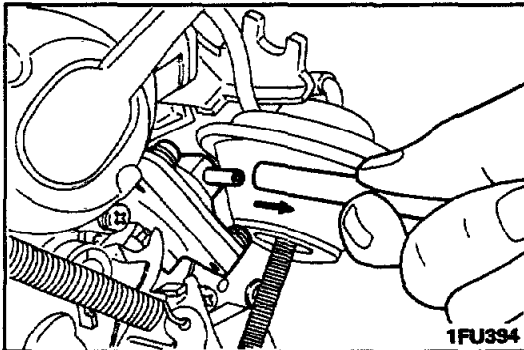

1FU394

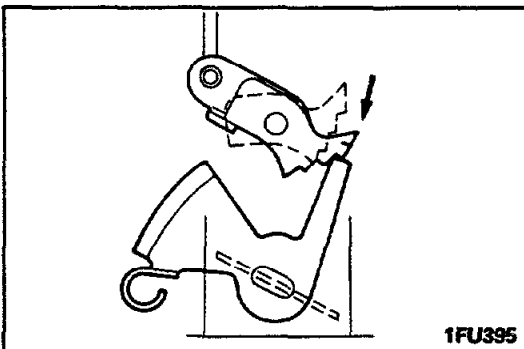

1FU395

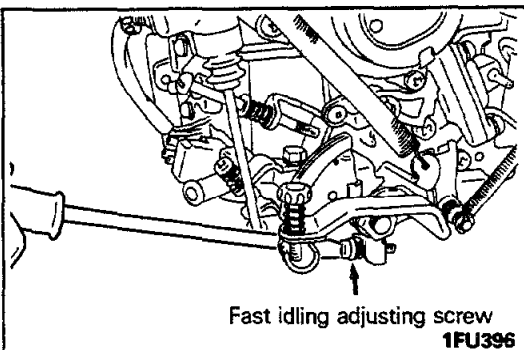

Fast idling adjusting screw

1FU396

Inspection Conditions

- Engine coolant temperature: 85 - 95°C (185 - 205°F)
- Lights and accessories: Set to OFF.
- Transmission: Neutral
- Steering wheel: Straightforward (vehicles with a power steering)

- (1) Remove the air cleaner.
- (2) Install the tachometer.

- (3) Disconnect the vacuum hose (white stripe) from the choke opener.
- (4) Set the lever on the second highest detent of fast idle cam.

- (5) Start the engine and check the fast idle speed.

Standard value : 2350 rpm

- (6) If the fast idle speed is out of specification, adjust with the fast idle adjusting screw.

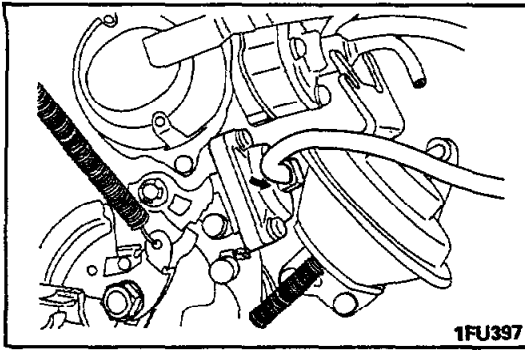

NOTE

Rotation direction of adjusting screw and fast idle speed

Adjusting screw direction	Valve opening	Fast idle speed
Clockwise	Large	Increases
Counter-clockwise	Small	Decreases

- Connect the vacuum hose removed in step (3) to the choke opener and check that the choke opener cancels fast idle.

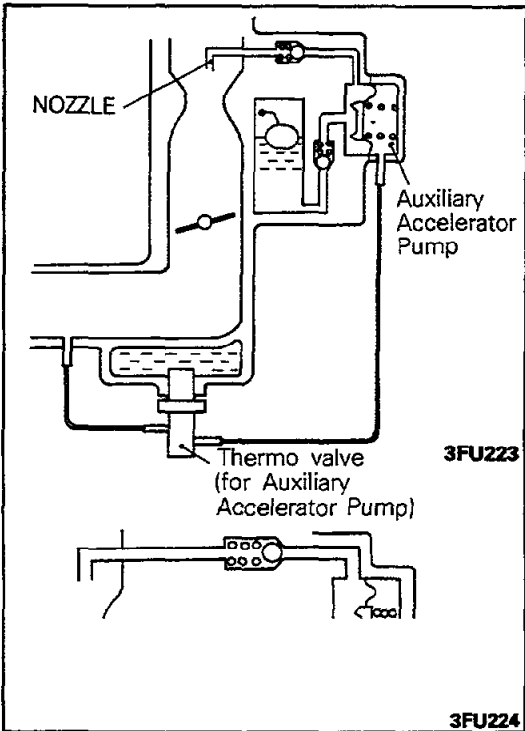

AUXILIARY ACCELERATION PUMP

N14FYAAb

- Remove the air cleaner cover.
- Check to be sure that the engine coolant temperature is 30°C (86°F) or lower, and then check according to the steps in the table below.

Step	Check conditions	Vacuum hose Vacuum	Pump nozzle
1	With the engine idling, disconnect the black vacuum hose from the carburetor Auxiliary Accelerator Pump.	Vacuum is felt when the hose end is covered by a finger.	Fuel is sprayed from the nozzle when the hose is disconnected.
2	Warm-up the engine until the temperature of the engine coolant reaches 50°C (122°F) or higher.	Vacuum cannot be felt by the finger.	–

- If the change of the vacuum is incorrect, check the thermo valve for the Auxiliary Accelerator Pump. If vacuum is normal but fuel is not sprayed from the nozzle, clean the carburetor's fuel passage.

THERMO VALVE (FOR AUXILIARY ACCELERATOR PUMP CONTROL)

N14FZAAb

- Disconnect the vacuum hose (black) from the thermo valve and connect a manual vacuum pump to the thermo valve.
- Apply a vacuum of 66 kPa (10.0 psi) to the thermo valve.

When engine is cold [coolant temperature 30°C (86°F) or lower]	Vacuum is not applied (leakage).
After engine warm-up [coolant temperature 50°C (122°F) or higher]	Vacuum is applied (no leakage).

- If incorrect, replace the thermo valve.

Caution

- Do not use a wrench or similar tool at the resin part when removing or installing the thermo valve.
- When installing, apply a coating of an anaerobic sealant to the threaded part, and then tighten at a torque of 20–35 Nm (14–25 ft.lbs.).

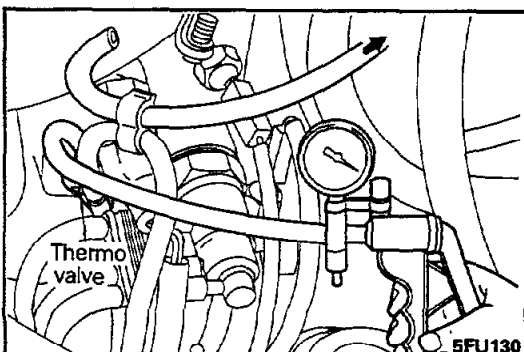

THROTTLE OPENER CONTROL SYSTEM FOR AIR CONDITIONER LOAD

N14PGBBb

Inspection Condition

Engine coolant temperature : 85 – 95°C (185 – 205°F)

- (1) Disconnect the vacuum hose (yellow stripe) from the throttle opener installed on the carburetor and connect a hand vacuum pump to the nipple.
- (2) Check that the throttle opener rod is pulled up when vacuum is applied.
- (3) Apply 67 kPa (10.0 psi) vacuum and check air tightness.
- (4) Start the engine and close the vacuum hose (yellow stripe) end with a finger to check vacuum when the air conditioner switch is turned on and off.

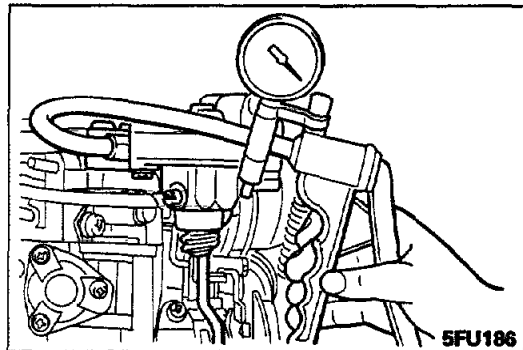

Air conditioner switch	Engine speed	Hose end vacuum
OFF	Idle	Absent
ON		Present
		1,200 rpm or more

FUEL FILTER REPLACEMENT

N14FCABb

refer to GROUP 0 – Fuel Filter (Replace)

OVERFILL LIMITER (TWO-WAY VALVE) REPLACEMENT

N14FEAG1

- (1) Remove the fuel filter hose protector.
- (2) Disconnect the vapor hoses, and then remove the overfill limiter.

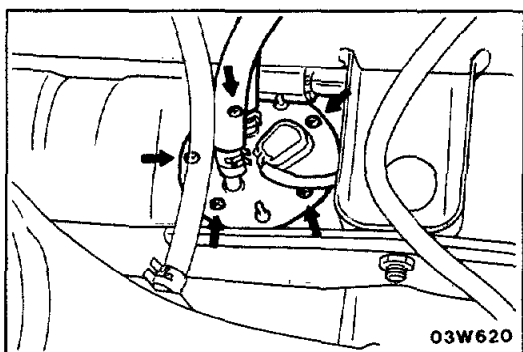
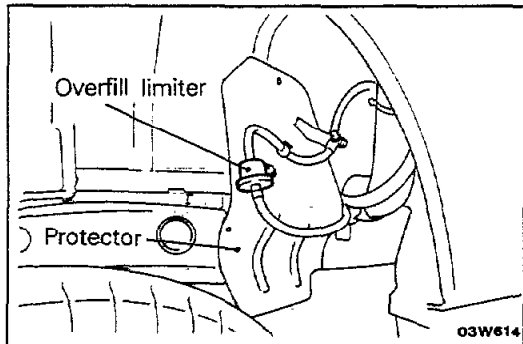
**FUEL GAUGE UNIT AND PIPE ASSEMBLY REPLACEMENT**

N14FFAJ

- (1) Remove the fuel tank cap and lower the fuel tank's internal pressure.
- (2) Disconnect the harness connector from the fuel gauge unit.
- (3) Remove the fuel gauge unit installation screws, and then remove the fuel gauge unit and pipe assembly from the fuel tank.

**FBC SYSTEM INSPECTION
COMPONENTS LOCATION**

N14ED-

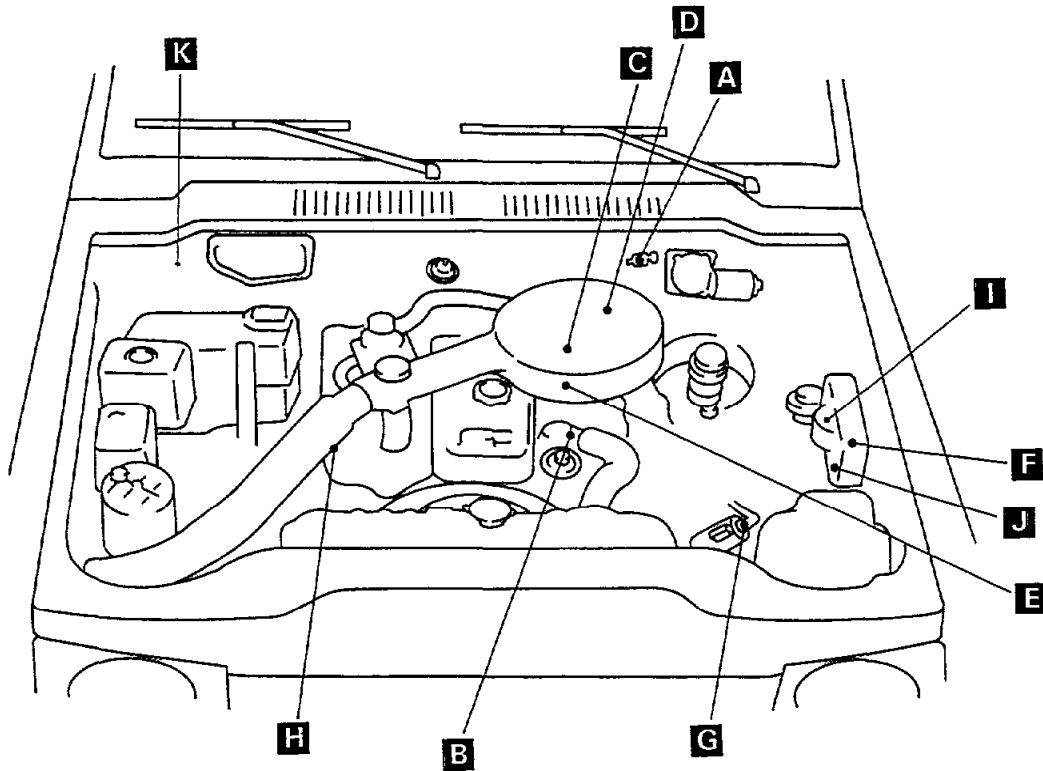

5FU131

Name	Symbol	Name	Symbol
Throttle opener control solenoid valve (for air conditioner)	A	Engine-speed sensor (ignition coil ⊖)	G
Engine coolant temperature sensor	B	Oxygen sensor	H
Feedback solenoid valve	C	Secondary air control solenoid valve	I
Slow-cut solenoid valve	D	Electric choke relay	J
Throttle-position sensor	E	Engine control unit	K
Vacuum switch	F	—	—

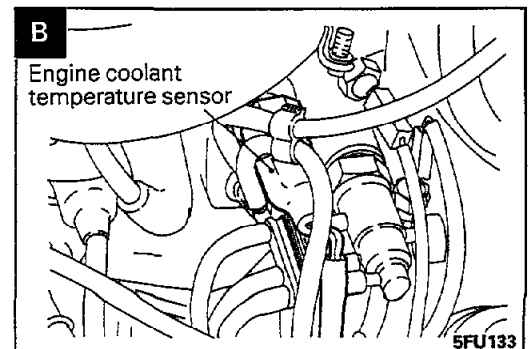
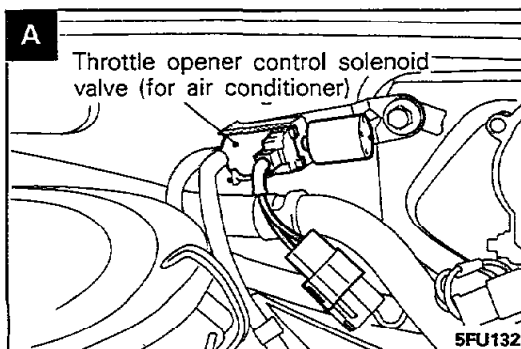

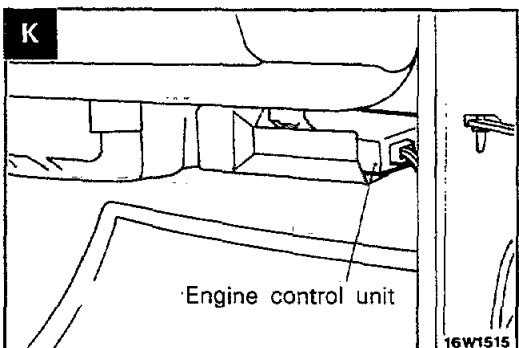
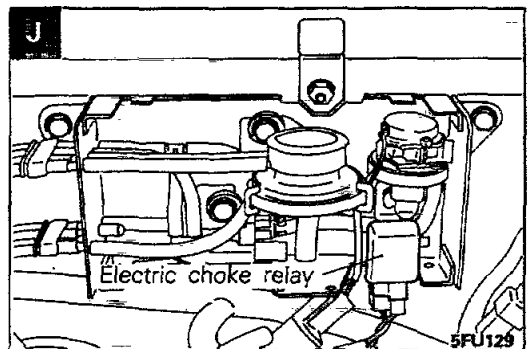
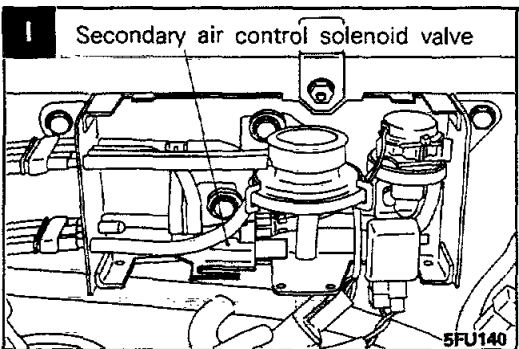
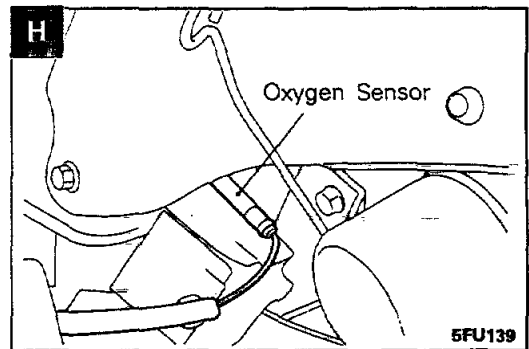
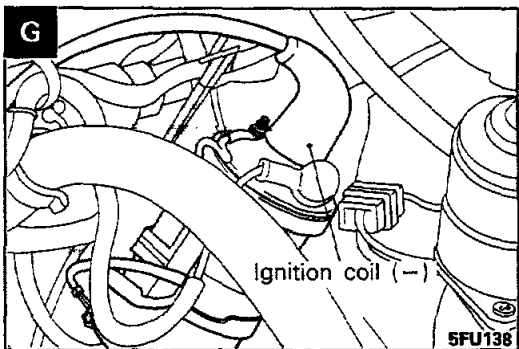
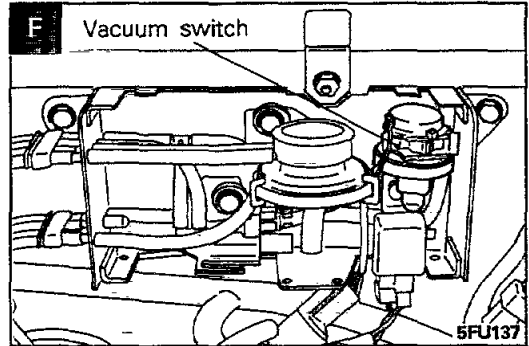
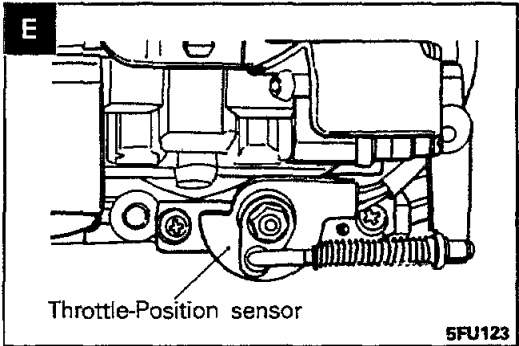
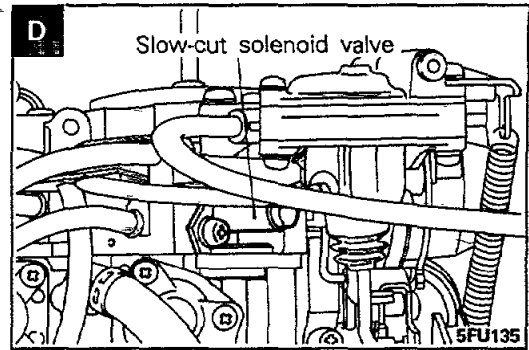
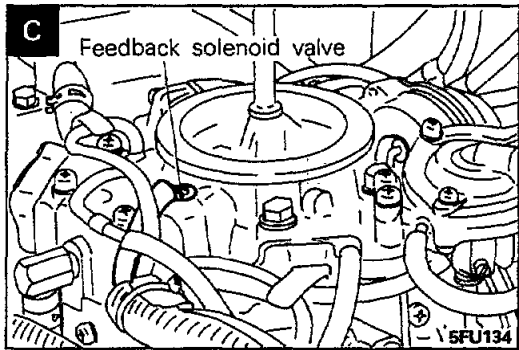

1. Before removing or installing a part, disconnect the battery – terminal.
2. Before disconnecting battery terminals, turn off the ignition switch. Removal or connection of battery terminals during engine operation or with the ignition switch ON could cause erroneous operation of the Engine control unit or damage to semiconductors.
3. The control harnesses between Engine control unit and ignition coil [– terminal] and between Engine control unit and oxygen sensor are shielded wires with shield grounded to the vehicle body in order to prevent ignition noises and radio interference. When the shielded wire is faulty, therefore, the control harness must be replaced.
4. When ECI checker is handled, pay attention to the following points.
 - Avoid rough operation of switches.
 - Do not subject ECI checker to shock and other external forces, heat, etc.
 - Keep away water and oil.
 - Store ECI checker in a moisture- and dust-free place and take steps to protect the checker from heat and vibration.

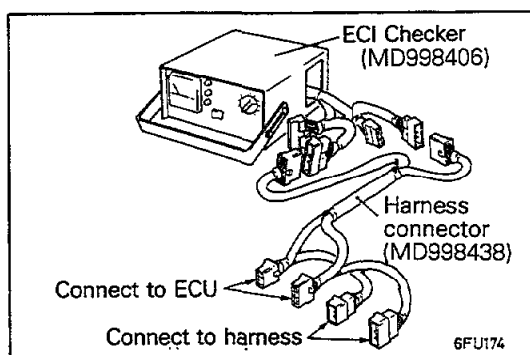

FBC SYSTEM INSPECTION (USE ECI CHECKER)

N14PDAG

Inspection and maintenance of electric system in the FBC system can be made quickly by inspecting the Engine control unit input and output electric signals with the ECI checker and then by inspecting the component whose signal is abnormal and the harness between the component and the Engine control unit.

Using the special tools (FBC Test Harness and ECI Checker), check the FBC system by the following procedure.

Inspection Procedure:

- (1) Turn ignition switch to "LOCK".
- (2) Remove the ECI cover.
- (3) Disconnect the Large harness connector and Small harness connector from the Engine control unit.
- (4) Set check switch of the ECI checker to OFF.
- (5) Set select switch of the ECI checker to A.
- (6) Connect the FBC Test Harness to the connectors of the ECI checker, and then connect the FBC Test Harness to the Engine control unit and harness connectors.
- (7) Perform checks according to the FBC System Check Procedure chart.
- (8) If checker shows any variance from specifications, check the corresponding sensor and related electrical wiring then repair or replacement.
- (9) After repair or replacement, recheck with the ECI checker to confirm that the repair has corrected the problem.
- (10) Set check switch of the ECI checker to OFF.
- (11) Set ignition switch to "Lock".
- (12) Disconnect connectors of the ECI checker and the FBC Test Harness from the Engine control unit and the body side harness connectors.
- (13) Connect the body side harness connectors to the Engine control unit.
- (14) After completion of the above test make certain that the trouble has been eliminated on the road test.

FBC SYSTEM CHECK PROCEDURE CHART (Use FBC Test Harness MD998438)

ECI Checker Operation		Check Item	Engine control unit Terminal No. Checked	Condition		Test Specification
Select Switch	Check Switch					
Set to "A"	1	Power supply	12	Ignition switch "LOCK→ON"		SV
	2	Ignition pulse	5	Ignition switch "LOCK→START"		2V to 8V
	3	Throttle position sensor	2	Ignition switch "LOCK→ON"	Accelerator fully closed	0.4V to 0.7V
					Accelerator fully opened	4.5V to 5.5V
	4	Engine coolant temperature sensor	3	Ignition switch "LOCK→ON"	0°C (32°F)	3.4V to 3.6V
					20°C (68°F)	2.4V to 2.7V
					40°C (104°F)	1.5V to 1.8V
					80°C (176°F)	0.5V to 0.7V
	5	Power supply for sensor	8	Ignition switch "LOCK→ON"		4.5V to 5.5V
	6					
	7	Vacuum switch for idle position	10	Ignition switch "LOCK→ON"		9V to 13V
				Idling (warm engine)		0V to 0.6V
8						
9	Feed back solenoid valve	52	Ignition switch "LOCK→ON"		SV	
			Idling (warm engine)		2V to 12V	
10	Slow cut-off solenoid valve	56	Idling		0V to 0.6V	
			Quick deceleration from above 4000 rpm to idling with "N" position		Momentarily SV	
11						
12						

NOTE
SV = System Voltage

FBC SYSTEM CHECK PROCEDURE CHART (Use FBC Test Harness MD998438)

ECI Checker Operation		Check Item	Engine control unit Terminal No. Checked	Condition		Test Specification
Select Switch	Check Switch			Test Result		
Set to "B"	1	Idle up control solenoid valve	57	Idling	A/C switch ON*1	0V to 0.6V
				2000 rpm		9V to 15V
	2	A/C cut-off relay	54	Ignition switch "LOCK→ON" and A/C switch "ON"*1	Accelerator fully closed	0V to 0.6V
					Accelerator fully opened	0V to 0.6V
	3					
	4	Secondary air control solenoid valve	58	Idling 70 seconds after start of warm engine		0V to 0.6V then SV
				Quick deceleration from above 2000 rpm to idling with "N"		Momentarily drop
	5					
	6	Electric choke relay	59	Ignition switch "LOCK→ON"		0V to 0.6V
				Idling		13V to 15V
	7					
	8	Oxygen sensor	1	Hold rpm constant above 1300 rpm, after 70 seconds from start of warm engine		0V to 1V ↑ (pulsates) ↓ *2V to 3V
9						
10						
11						
12						

NOTE

*1 ON means compressor clutch engaged.

*2 Failure of parts other than the oxygen sensor can also cause deviation from the specifications. Also check other parts related to air-fuel ratio control, which are listed on page 14-8.

SV = System voltage

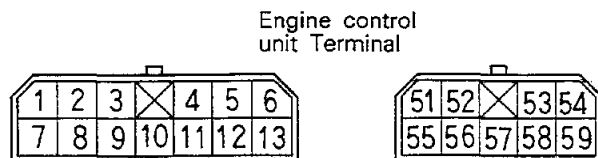

View from front as installed in Engine control unit

03P0089

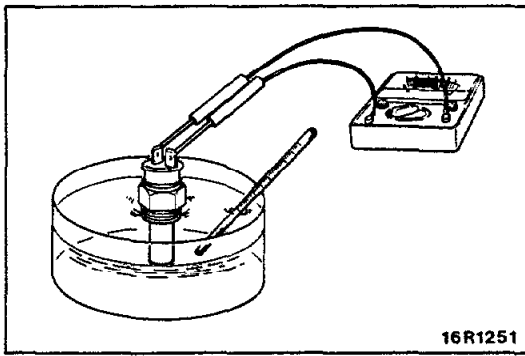

16R1251

ENGINE COOLANT TEMPERATURE SENSOR N140AAA

INSPECTION

- (1) Remove engine coolant temperature sensor from the intake manifold.
- (2) With temperature sensing portion of engine coolant temperature sensor immersed in hot water, check electrical resistance. The sensor should be held with its housing 3 mm (.12 in.) away from the surface of the hot water.

Temperature °C (°F)	Resistance (kΩ)
0 (32)	5.9
20 (68)	2.5
40 (104)	1.1
80 (176)	0.3

- (3) If the resistance deviates greatly from the standard value, replace the engine coolant temperature sensor.

INSTALLATION

- (1) Apply anaerobic sealant to threaded portion.
- (2) Install engine coolant temperature sensor and tighten it to specified torque.

Sensor tightening torque : 20 – 40 Nm (14 – 29 ft. lbs.)

- (3) Fasten harness connectors securely.

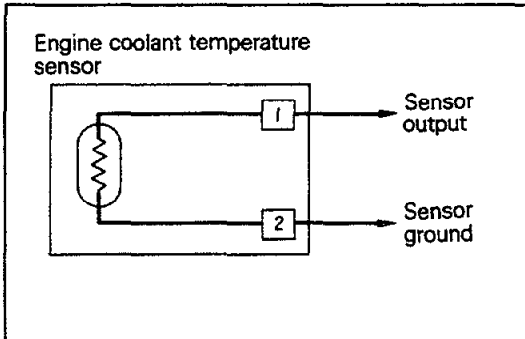

01R0129

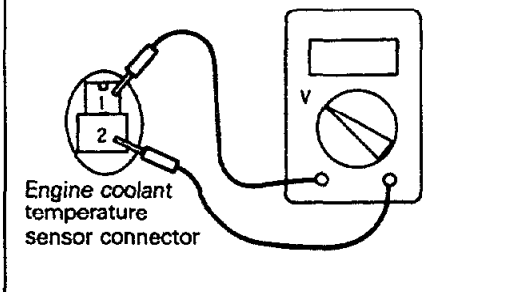

01R0133

THROTTLE POSITION SENSOR N14QBAC

INSPECTION

- (1) Disconnect the carburetor connector.
- (2) Measure resistance between terminal 4 (sensor power) and terminal 8 (sensor ground).

Standard value : 3.5 – 6.5 KΩ

- (3) Connect an ohmmeter (pointer type) between terminal 8 (sensor ground) and terminal 3 (sensor output).
- (4) Operate the throttle valve slowly from idle position to the full open position and check that the resistance makes a smooth change proportionally with the throttle valve opening.

NOTE

The resistance changes within the range from approx.0.5 kΩ to the value measured at step (2).

- (5) If the resistance is out of specification or fails to change smoothly, replace the throttle position sensor.

TPS installation torque : 2.5 – 4.5 Nm (1.8 – 3.3 ft. lbs.)

NOTE

Refer to P.14-13 for the throttle position sensor adjusting procedure.

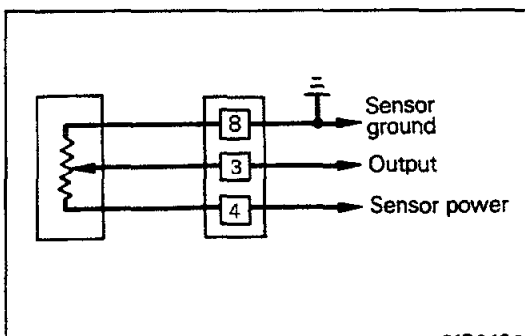

01R0490

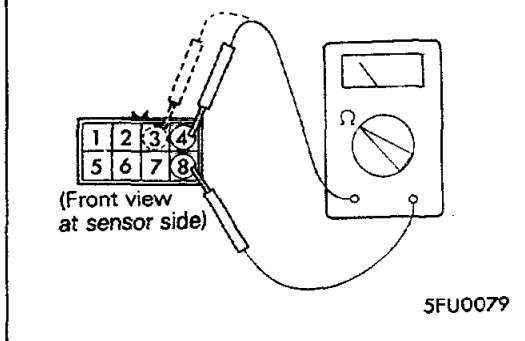

5FU0079

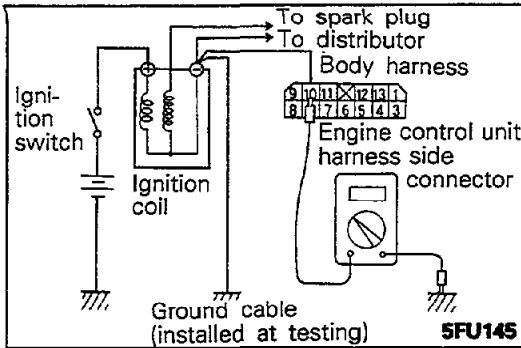

ENGINE SPEED SENSOR (IGNITION COIL TERMINAL)

N14QCAB5

INSPECTION

Check that there is continuity between the ignition coil – terminal and the electronic control unit terminal 10.

NOTE

Shake the harness connector to check for lurking open circuit.

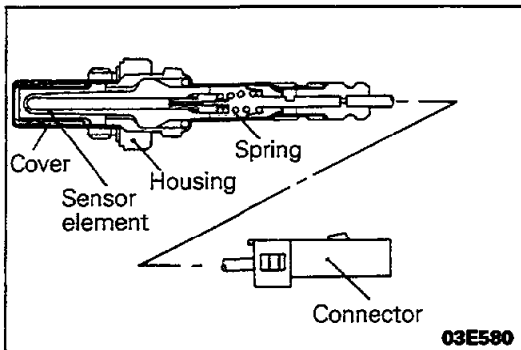

OXYGEN SENSOR

N14QDAAB

INSPECTION

Caution

1. Before checking, warm up the engine until engine coolant temperature reaches 85 to 95° (185 to 205°F).
2. Use an accurate digital voltmeter.

- (1) Disconnect the oxygen sensor connector and connect a voltmeter to the oxygen sensor connector.
- (2) While repeating engine racing, measure the oxygen sensor output voltage.

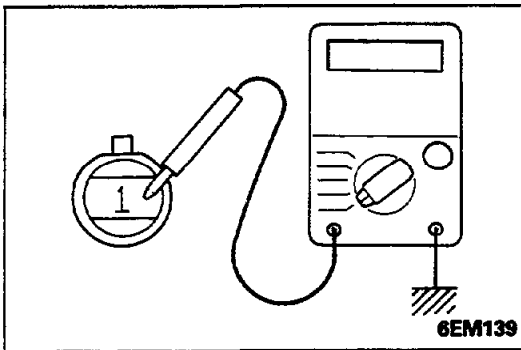

Engine	Oxygen sensor output voltage	Remarks
Racing	Approx. 1 V	Make air-fuel mixture richer by accelerator operation

NOTE

For removal and installation of the oxygen sensor, refer to GROUP 11 – Exhaust Manifold.

Oxygen sensor installation torque : 40 – 50 Nm (30 – 36 ft. lbs.)

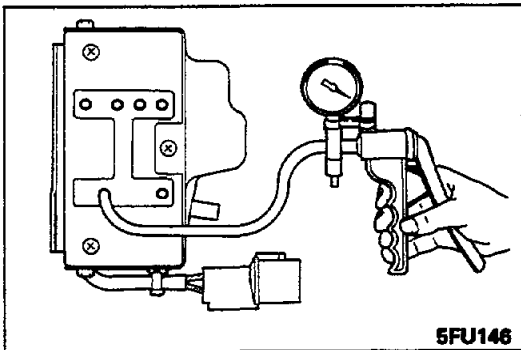

VACUUM SWITCH

N14QIAB

INSPECTION

- (1) Disconnect the vacuum hose (green stripe) from the device box, and connect a manual vacuum pump to the device box nipple.
- (2) Disconnect the vacuum switch connector
- (3) Apply negative pressure (vacuum) and check whether or not there is continuity between the switch terminals.

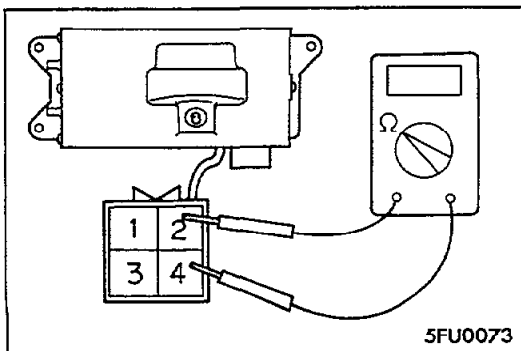

Vacuum gauge	Measured terminals	Continuity
26 kPa (3.9 psi) or lower	②-④	No ($\infty \Omega$)
40 kPa (5.8 psi) or higher	②-④	Yes (0 Ω)

- (4) If there is a problem, remove the device box cover, and replace the vacuum switch assembly.

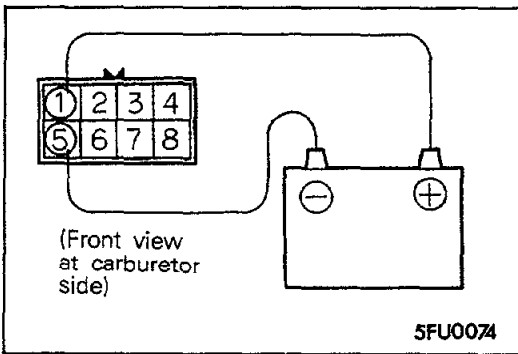

FEEDBACK SOLENOID VALVE INSPECTION

N14Q0ABb

- (1) Disconnect the carburetor connector.
- (2) Apply battery voltage (approx. 12V) between the solenoid valve terminals and check that the solenoid valve operates with a click.
If no click is heard, replace the solenoid valve.

NOTE

For the feedback solenoid valve removal and inspection procedures, refer to CARBURETOR DISASSEMBLY AND REASSEMBLY, P.14-35.

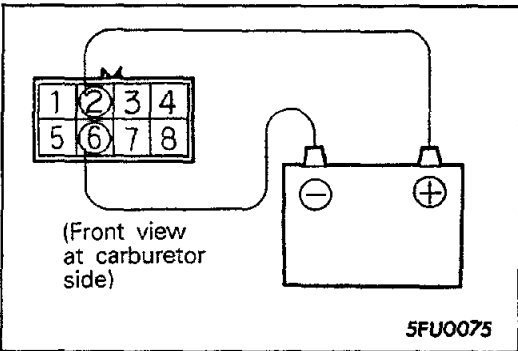

SLOW CUT SOLENOID VALVE INSPECTION

N14QPABb

- (1) Disconnect the carburetor connector.
- (2) Apply battery voltage (approx. 12V) between the solenoid valve terminals and check that the solenoid valve operates with a click.
If no click is heard, replace the solenoid valve.

NOTE

For the slow cut solenoid valve removal and inspection procedures, refer to CARBURETOR DISASSEMBLY AND REASSEMBLY, P.14-35.

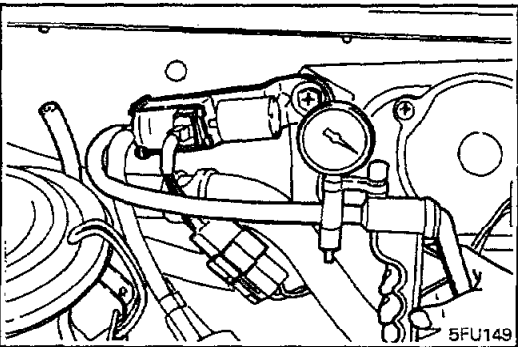

THROTTLE OPENER CONTROL SOLENOID VALVE FOR AIR CONDITIONER

N14QXBAa

INSPECTION

NOTE

When disconnecting the vacuum hoses from the solenoid valve, put marks on the hoses for correct installation.

- (1) Disconnect the vacuum hoses (white stripe, yellow stripe) from the solenoid valve.
- (2) Disconnect the harness connector.
- (3) Connect a hand vacuum pump to the nipple to which the white stripe vacuum hose been connected.
- (4) Apply vacuum and check air tightness for both when battery voltage is directly applied to the solenoid valve terminal and when no voltage is applied.

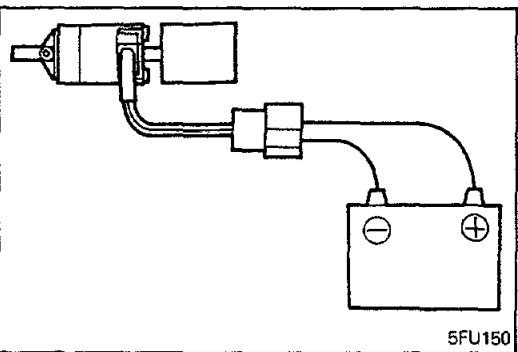

Battery voltage	The other nipple of solenoid valve	Normal state
Applied	Open	Vacuum leaks
	Closed with finger	Vacuum is held
Not applied	Open	Vacuum is held

- (5) Measure the solenoid coil resistance.

Standard value : 40 – 48Ω [at 20°C (68°F)]

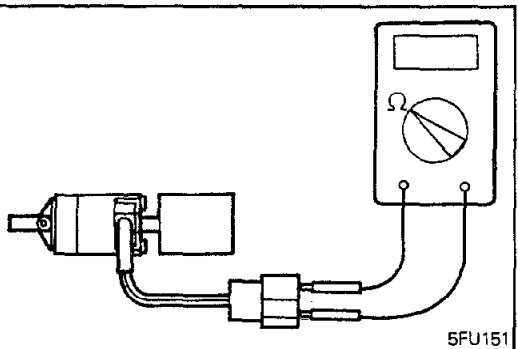

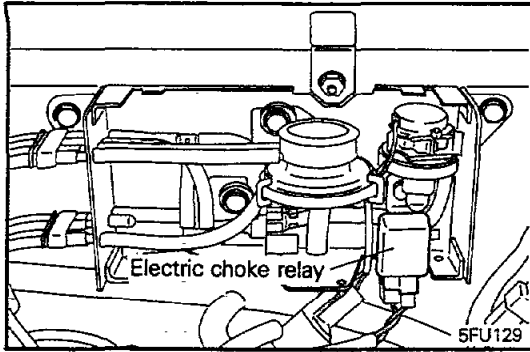

ELECTRIC CHOKE RELAY

N14FQDB

INSPECTION

- (1) Remove the cover of the device box and remove the electric choke relay.
- (2) Check for continuity between terminals when there is and is not current flow to the relay coil.

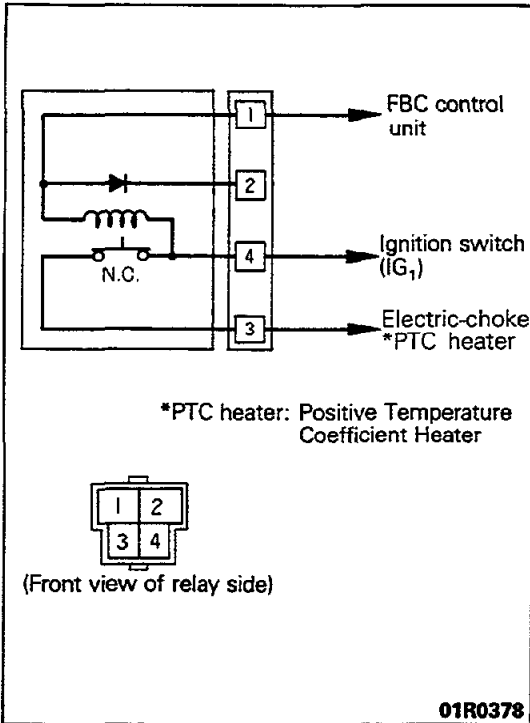

Item	Measured terminals	Continuity
No power flow	Between terminals ① → ②	Yes (0Ω)
	Between terminals ① → ③	No (∞Ω)
	Between terminals ① → ④	Yes (approx. 100Ω)
	Between terminals ③ → ④	Yes (0Ω)
Power flow	Between terminals ③ → ④	No (∞Ω)

NOTE

1. → indicates the current flow direction.
2. Inspect after checking the infinity of tester.
3. To energize the relay coil, apply battery voltage directly to terminals ①-④.
4. Use care as application of battery voltage to incorrect terminals can cause damage to the relay.

- (3) If the continuity test fails, replace the electric choke relay.

NOTE

If the electric choke body remains cool after engine start although the electric choke heater (PTC heater) and electric choke relay are normal, check the vehicle body harness circuit.

CARBURETOR

REMOVAL AND INSTALLATION

N14MA-

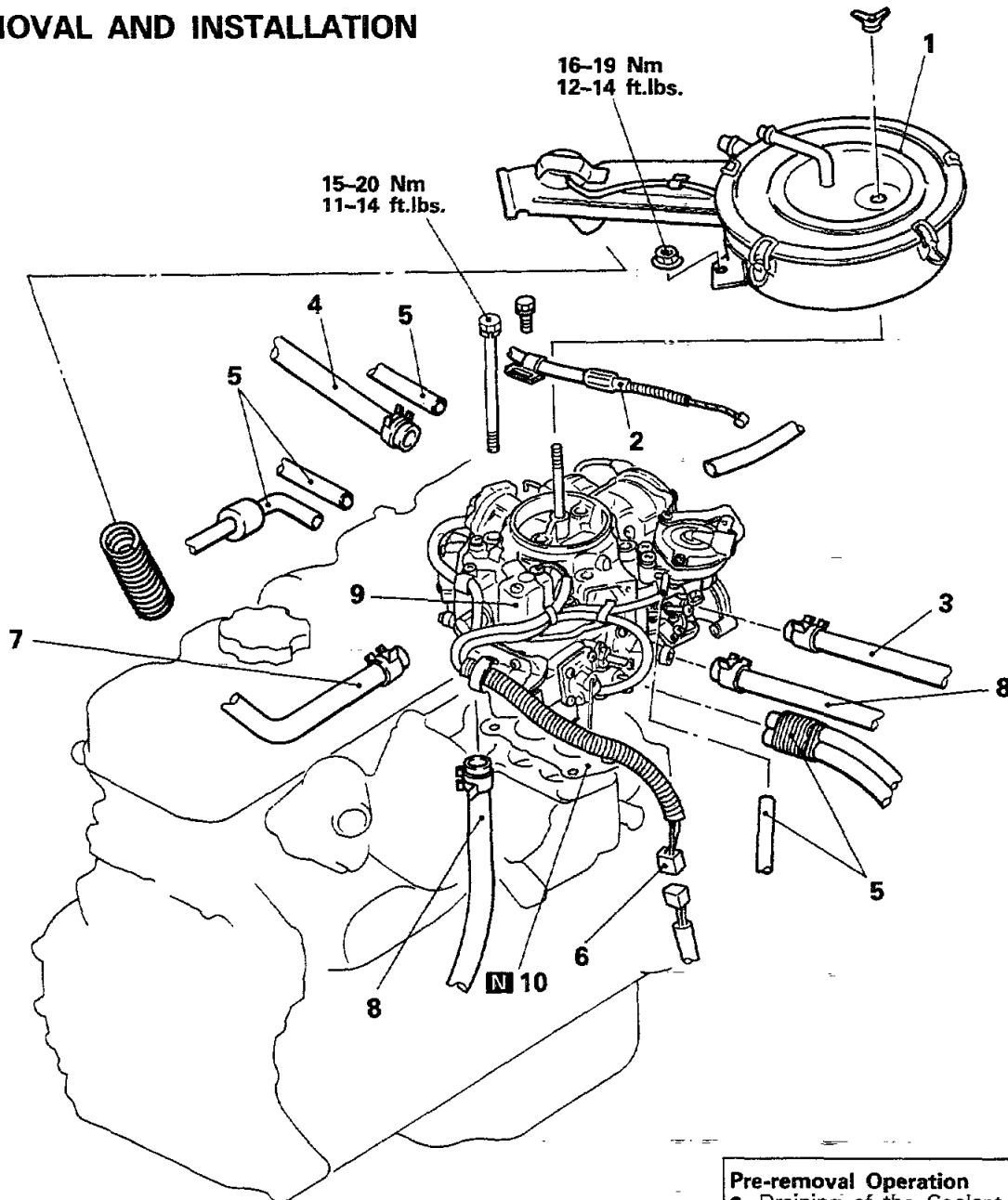

Removal steps

- ◄◄ ►► 1. Air cleaner
- Adjustment of accelerator cable
- 2. Connection for accelerator cable
- 3. Connection for water hose
- 4. Connection for fuel vapor hose
- 5. Connection for vacuum hoses
- 6. Connection for control harness connector
- ◄◄ 7. Connection for main hose
- ◄◄ 8. Connection for return hose
- ◄◄ 9. Carburetor
- 10. Gasket

Pre-removal Operation

- Draining of the Coolant (Refer to GROUP 0 - Coolant Replacement.)

Post-installation Operation

- Supplying of Coolant (Refer to GROUP 0 - Coolant Replacement.)
- Checking and Adjustment of the Idling rpm (Refer to GROUP 0 - Checking and Adjustment of the Idling rpm.)

NOTE

- (1) Reverse the removal procedures to reinstall.
- (2) ◄◄ : Refer to "Service Points of Removal".
- (3) ►► : Refer to "Service Points of Installation".
- (4) N : Non-reusable parts

03W552

SERVICE POINTS OF REMOVAL

N14MBACb

1. REMOVAL OF AIR CLEANER

Refer to GROUP 11 – Air cleaner.

7. DISCONNECTION OF MAIN HOSE/8. RETURN HOSE

- (1) Before disconnection of the fuel hose, remove the fuel tank cap to lower the pressure in the fuel tank.
- (2) With the receiver placed under the fuel inlet fitting to receive fuel left in the hose, remove fuel hose from the carburetor inlet nipple.

9. REMOVAL OF CARBURETOR

NOTE

When the carburetor is removed, keep it horizontally so as not to spill fuel from the carburetor.

SERVICE POINTS OF INSTALLATION

N14MDAC

• ADJUSTMENT OF ACCELERATOR CABLE FREE PLAY

Refer to P.14-102.

1. INSTALLATION OF AIR FILTER

Refer to GROUP 11 – Air cleaner.

DISASSEMBLY AND REASSEMBLY

N14ME-

Disassembly steps

1. Throttle-return spring
2. Damper spring
3. Throttle-return spring bracket
4. Throttle opener/Dash pot

NOTE

- (1) Reverse the disassembly procedures to reassemble.
- (2) ⇄ : Refer to "Service Points of Disassembly".
- (3) ⇄ : Refer to "Service Points of Reassembly".
- (4) [N] : Non-reusable parts

Carburetor assembly and gasket kit

03W556

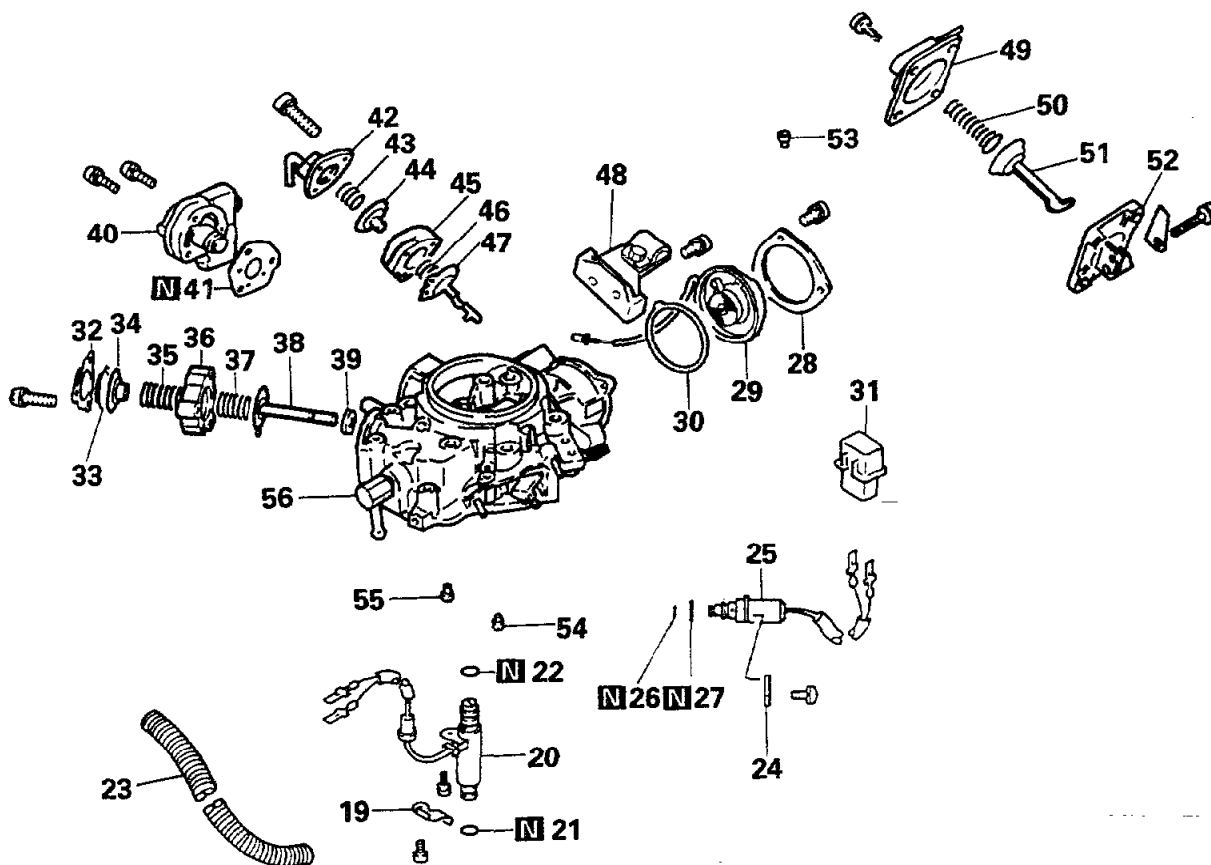
**Disassembly steps**

- 13. Pin
- ◄◄ 14. Float
- ◄◄ 15. Needle valve
- ◄◄ 16. Needle valve seat
- 17. O-ring
- 18. Packing
- 19. Retainer
- ◄◄ ◄◄ 20. Feedback solenoid valve
- 21. O-ring
- 22. O-ring
- 23. Tube
- 24. Retainer
- ◄◄ ◄◄ 25. Slow-cut solenoid valve
- 26. O-ring
- 27. O-ring
- 28. Plate
- ◄◄ ◄◄ 29. Bimetal assembly
- 30. Packing
- 31. Connector
- 32. Cover
- 33. Diaphragm
- 34. Spring seat
- 35. Spring
- 36. Body

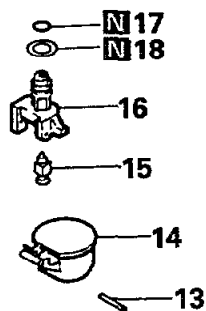

- 37. Spring
- 38. Diaphragm
- 39. Valve
- 40. Mixture control valve assembly
- 41. Gasket
- 42. Cover
- 43. Spring
- 44. Diaphragm
- 45. Body
- 46. Spring
- 47. Diaphragm
- 48. Bracket
- 49. Cover
- 50. Spring
- 51. Diaphragm
- 52. Body
- ◄◄ ◄◄ 53. Main air jet (primary)
- ◄◄ ◄◄ 54. Pilot jet (primary)
- ◄◄ ◄◄ 55. Pilot jet (secondary)
- 56. Float chamber cover

NOTE

- (1) Reverse the disassembly procedures to reassemble.
- (2) ◄◄ : Refer to "Service Points of Disassembly".
- (3) ◄◄ ◄◄ : Refer to "Service Points of Reassembly".
- (4) N : Non-reusable parts

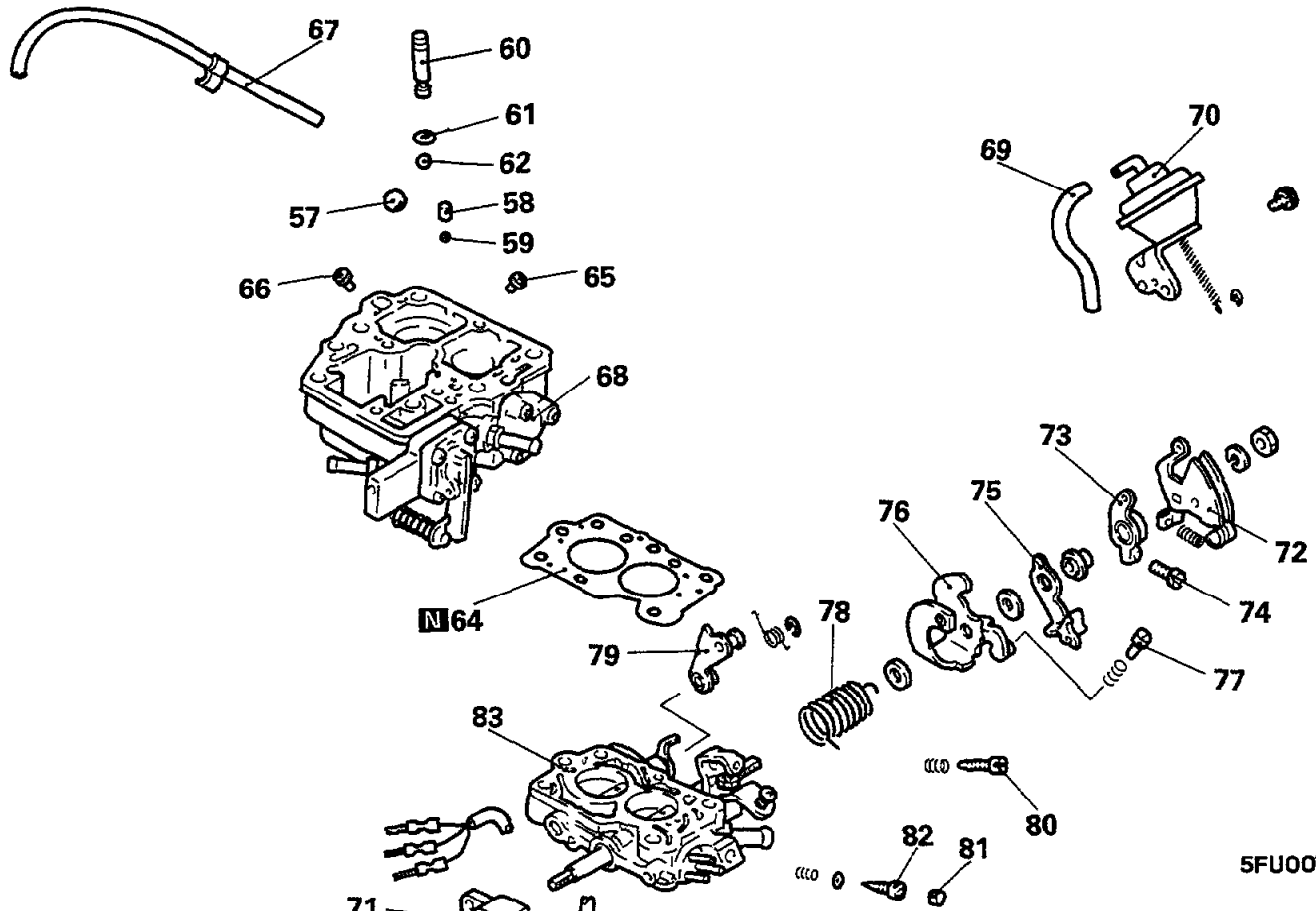

5FU0070

Disassembly steps

- ◆◆ 57. Steel ball
- ◆◆ 58. Weight
- ◆◆ 59. Ball
- ◆◆ 60. Plug
- ◆◆ 61. O-ring
- ◆◆ 62. Ball
- ◆◆ 63. Screw
- ◆◆ 64. Gasket
- ◆◆◆◆ 65. Main jet (primary)
- ◆◆◆◆ 66. Main jet (secondary)
- 67. Hose
- 68. Mixing body
- 69. Vacuum hose
- 70. Depression chamber
- 71. Throttle-position sensor

2.5-4.5 Nm
1.8-3.2 ft.lbs.

- 72. Throttle lever
- 73. Cam follower
- 74. Fast-idle adjustment screw
- 75. Free lever
- 76. Apartment plate
- 77. Idle-speed adjustment screw (SAS-2)
- 78. Spring
- 79. Secondary lever
- 80. Idle-speed adjustment screw (SAS-1)
- 81. Concealment plug
- 82. Mixture-adjustment screw
- 83. Throttle body

NOTE

- (1) Reverse the disassembly procedures to reassemble.
- (2) ◆◆ : Refer to "Service Points of Disassembly".
- (3) ◆◆◆◆ : Refer to "Service Points of Reassembly".
- (4) N : Non-reusable parts

SERVICE POINTS OF DISASSEMBLY

N14MFAE

Caution

1. Do not disassemble the following components at the time of disassembly.
 - (1) Choke valve, choke shaft and automatic choke device
 - (2) Inner venturi
 - (3) Throttle valve and throttle shaft
 - (4) Fuel inlet nipple
2. When loosening a Philips screw which has been firmly tightened, use a Philips screwdriver that is an exact fit for the screw.

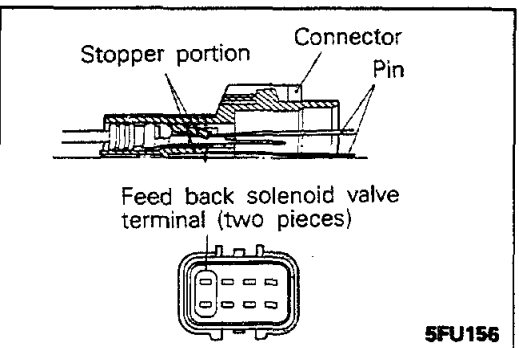
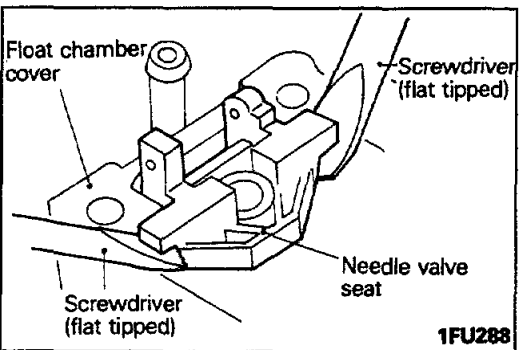
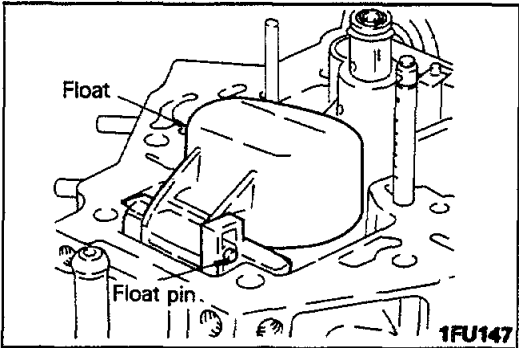
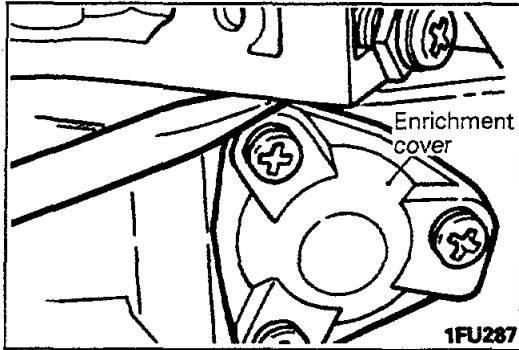
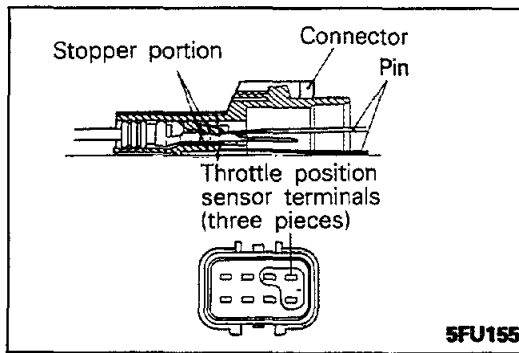

10. REMOVAL OF FLOAT CHAMBER COVER ASSEMBLY

Caution

Ensure that the terminal is not bent during removal of the connector.

- (1) With a pin or the like push the stopper portion to remove each of the three Throttle position sensor terminals from the rear of the connectors.

- (2) Do not attempt to remove the cover at a time as it is held in position firmly by gasket. Insert a screwdriver blade between the enrichment cover and the float chamber cover as illustrated and lightly pry and lift up lightly.

Caution

Do not apply excessive force.

14. REMOVAL OF FLOAT/15. NEEDLE VALVE

Remove the pin and then remove the float and needle valve.

Caution

1. Do not let the float drop or apply collapsing load.
2. Use care not to damage the end of the needle valve.

16. REMOVAL OF NEEDLE VALVE SEAT

Using flat blade screwdrivers, pry up the needle valve seat at both edges to remove.

Caution

Use care not to damage the float chamber cover when pushing up the needle valve seat.

20. REMOVAL OF FEEDBACK SOLENOID VALVE

Using a screwdriver or other tool with a thin flat end, push the stopper portion and remove the two terminals from behind the connector.

Caution

Ensure that the terminal is not bent during removal of the connector.

NOTE

Unless the terminals are removed from the connector, the feedback solenoid valve cannot be removed from the float chamber cover.

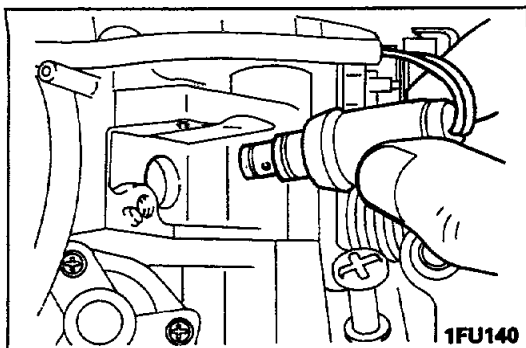

25. REMOVAL OF SLOW CUT SOLENOID VALVE

- (1) Remove the retainer and pull out the slow cut solenoid valve.

Caution
When removing the valve, do not hold the leads but hold the body.

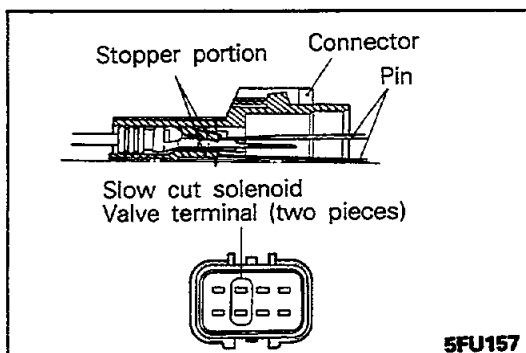

- (2) Using a screwdriver or other tool with a thin flat end, push the stopper section and remove the two terminals from behind the connector.

Caution
Ensure that the terminal is not bent during removal of the connector.

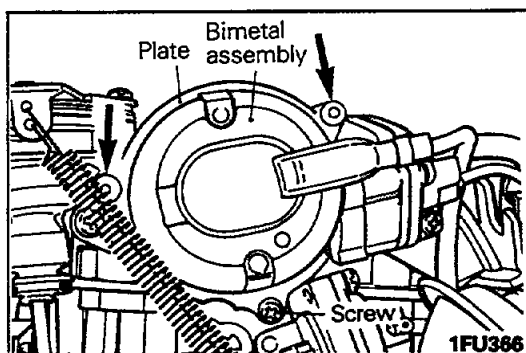

29. REMOVAL OF BIMETAL ASSEMBLY

- (1) Grind away the head of the two rivets of the bimetal assembly using an hand grinder or other tool. remove the screw.
- (2) Remove the plate, the bimetal assembly and the packing.
- (3) Remove the remaining rivet bodies using a pin punch etc..

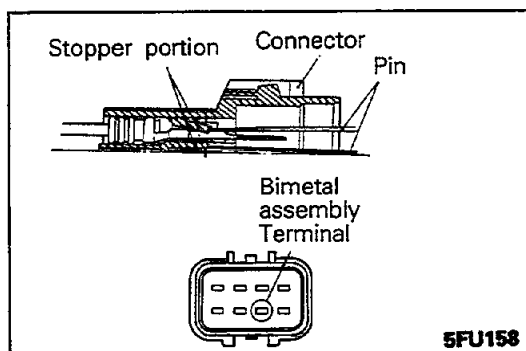

- (4) Using a screwdriver or other tool with a thin flat end, push the stopper section and remove the terminal from behind the connector.

Caution
Ensure that the terminal is not bent during removal of the connector.

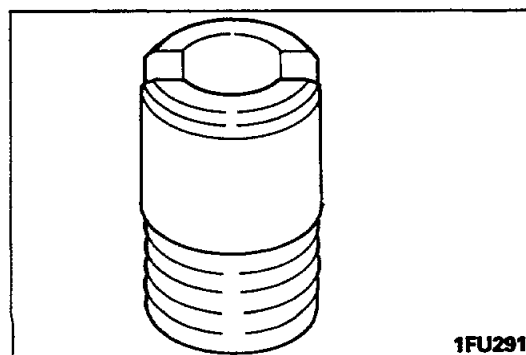

53. REMOVAL OF MAIN AIR JET (PRIMARY)/54. PILOT JET (PRIMARY)/55. PILOT JET (SECONDARY)

- (1) When removing the jets, use a screwdriver that is an exact fit for their slot and work carefully to prevent damage.

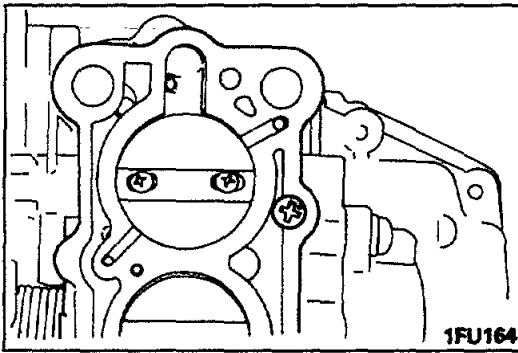
**63. REMOVAL OF SCREW**

- (1) Use a Phillips screwdriver that is an exact fit and work carefully to prevent damage.

Caution

Do not cause burrs to the recess in screw head as they could produce gap between throttle body and the manifold surface.

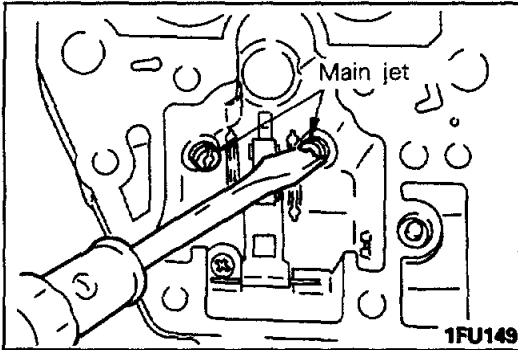
**65. REMOVAL OF MAIN JET (PRIMARY)/66. MAIN JET (SECONDARY)**

When removing the jets, use a screwdriver that is an exact fit and work carefully to prevent damage.

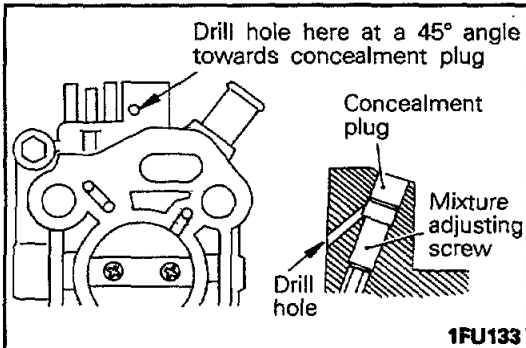
**81. REMOVAL OF CONCEALMENT PLUG**

- (1) Clamp carburetor in a vice with idle mixture adjusting screw facing up (protect gasket surface from vice jaws).
- (2) Drill a 2 mm (5/64 in.) pilot hole in the casting surrounding the idle mixture adjusting screw then redrill the hole to 3 mm (1/8 in.).
- (3) Insert a blunt punch into the hole and drive out plug.

INSPECTION

N14MGAA

GENERAL INSPECTION

Check the following and repair or replace parts if necessary.

- (1) Check the fuel paths (jets) and air paths (jets or orifices) for clogging. If clogged, wash thoroughly with cleaning solvent or detergent and blow by compressed air. Do not use metal wire or other metal pieces.
- (2) Check the diaphragms for damage and cracks.
- (3) Check that the needle valve operates lightly. If the valve is hard to slide or is binding, repair or replace. If there is overflow, poor valve to seat contact is suspected. Check thoroughly.
- (4) Check the fuel inlet filter (located above the needle valve) for clogging and damage.
- (5) Check the float operation. Check the float and lever for deformation and damage and replace if necessary.
- (6) Check operation of the throttle valve, choke valve and link. If they do not operate lightly, wash well and apply engine oil sparingly to their shaft.
- (7) Check the float chamber and main body for damage and cracks.

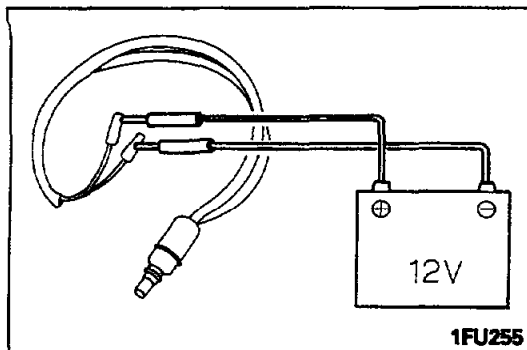

SLOW CUT SOLENOID VALVE OPERATION CHECK N14MG8Ab

- (1) Apply battery voltage directly to the slow cut solenoid valve terminals.
- (2) Check that the valve operates with a click.

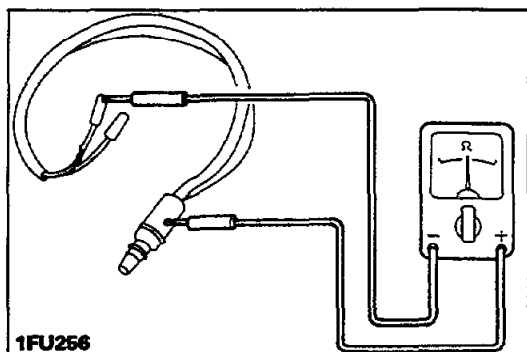

SLOW CUT SOLENOID VALVE RESISTANCE MEASUREMENT N14MGCAb

- (1) Using a circuit tester, check that there is no continuity between the solenoid valve body and terminals.

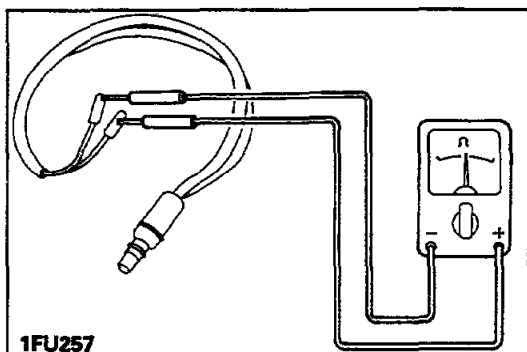

- (2) Measure resistance between the terminals.

Standard value : 48 – 60Ω [at 20°C (68°F)]

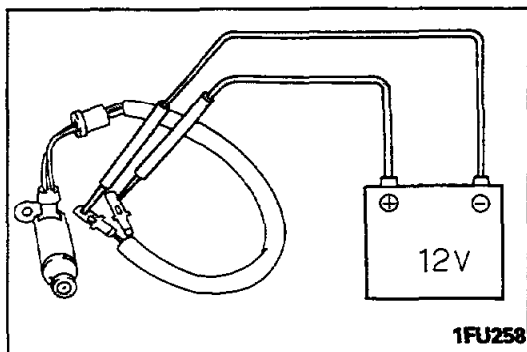

FEEDBACK SOLENOID VALVE OPERATION CHECK N14MGDAb

- (1) Apply battery voltage directly to the feedback solenoid valve terminals.
- (2) Check that the valve operates with a click.

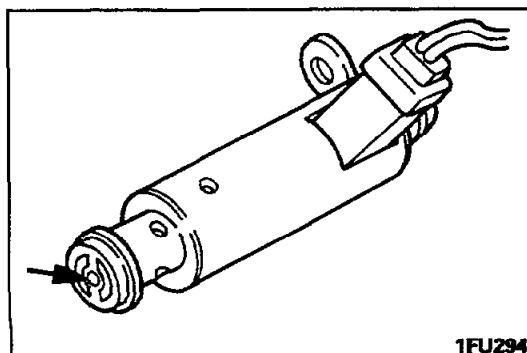

- (3) Check that the jet is free from clogging.

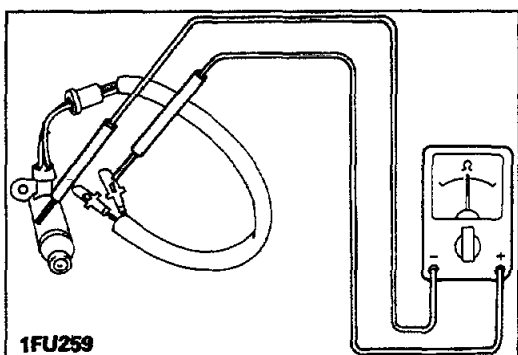

1FU259

FEEDBACK SOLENOID VALVE RESISTANCE MEASUREMENT

N14MGEAa

- (1) Using a circuit tester, check that there is no continuity between the solenoid valve body and terminals.

- (2) Measure resistance between the terminals.

Standard value : 54 - 66Ω [at 20°C (68°F)]

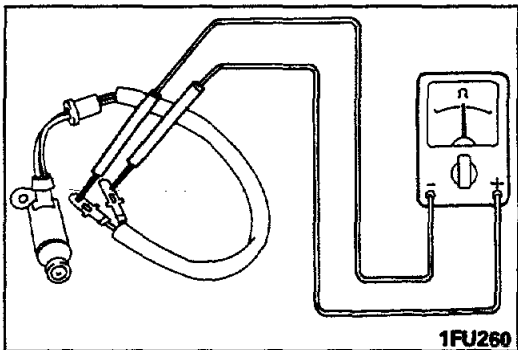

1FU260

BIMETAL ASSEMBLY RESISTANCE MEASUREMENT

N14MGFAa

Using a circuit tester, measure resistance between the terminal and body.

Standard value : Approx. 6Ω [at 20°C(68°F)]

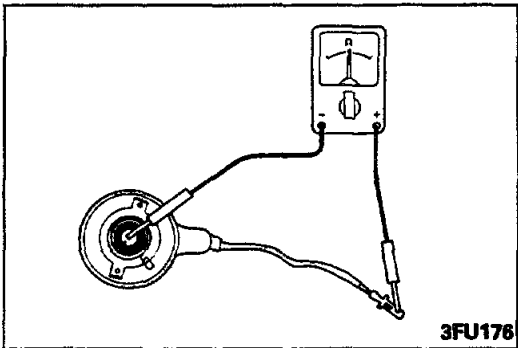

3FU176

DASH POT INSPECTION

N14MGGAa

Check that the dash pot operates normally. Resistance must be felt when the dash pot rod is pulled. When the rod is released, it must return quickly to the original position. If no resistance is felt when it is pulled, the diaphragm or the check valve is broken. If the rod returns slowly, the check valve is binding. In either case, replace the dash pot.

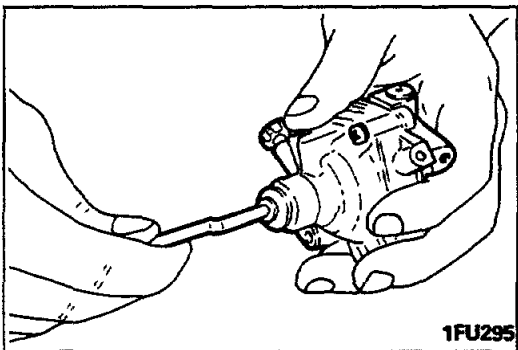

1FU295

DEPRESSION CHAMBER INSPECTION

N14MGHAa

Check the depression chamber diaphragm for damage. First, push up the rod fully and closing tightly the nipple with a finger, release the rod. The diaphragm is intact if the rod does not return to the initial position while the nipple is held closed with a finger. If the rod returns, the diaphragm is broken. Replace the depression chamber.

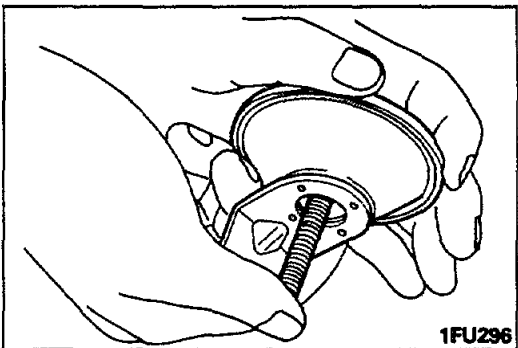

1FU296

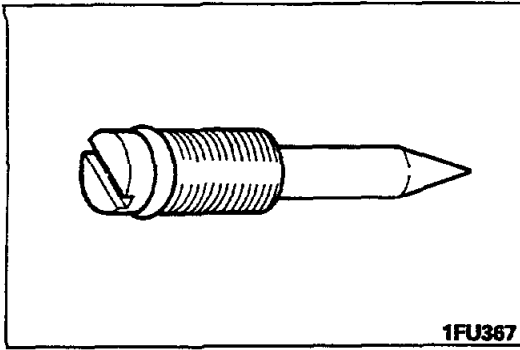

MIXTURE ADJUSTING SCREW INSPECTION

N14MGIAb

Check the mixture adjusting screw for damage caused to its taper end by overtightening etc..

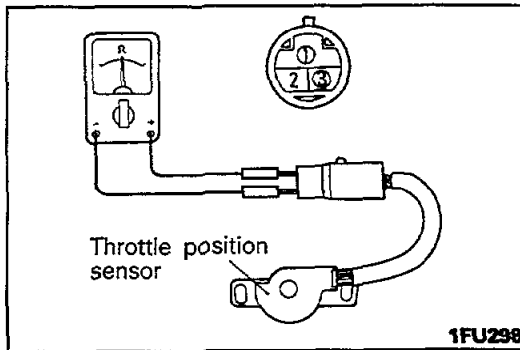

THROTTLE POSITION SENSOR INSPECTION

N14MGJAb

1. Measure resistance between terminals 1 and 3 of the throttle position sensor.

Standard value : 3.5 – 6.5 kΩ

2. Check the body for crack and damage.

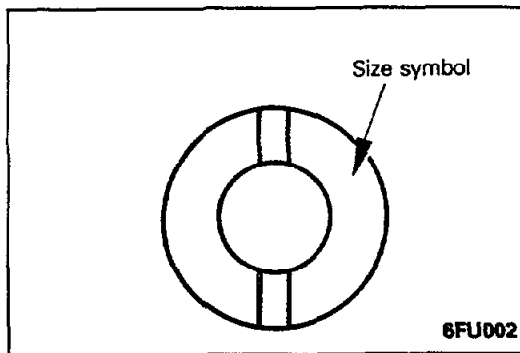

SERVICE POINTS OF REASSEMBLY

N14MHAD

66./65. IDENTIFICATION OF MAIN JETS

Make sure that correct jets are installed at correct positions.
Note the size symbol stamped on each jet for identification.

Primary : #107.5
Secondary : #190

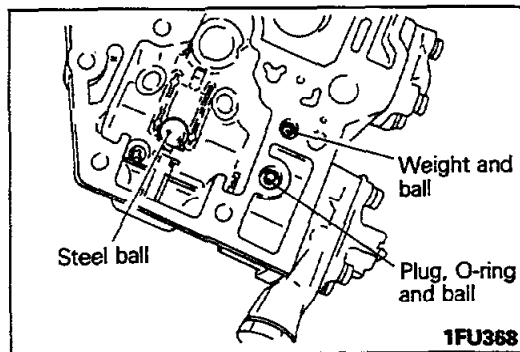

62. INSTALLATION OF BALL/61. O-RING/60.PLUG/59. BALL/58. WEIGHT/57. STEEL BALL

Install in correct sequence and at correct positions.

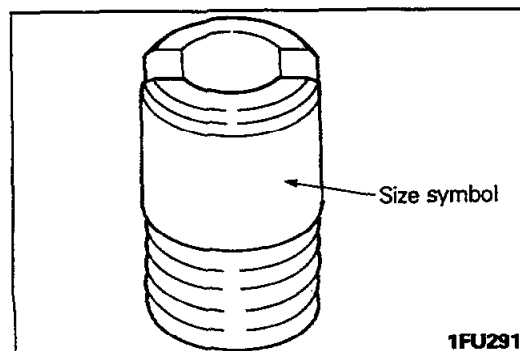

55. INSTALLATION OF PILOT JET (SECONDARY)/54. PILOT JET (PRIMARY)/53. MAIN AIR JET (PRIMARY)

Make sure that correct jets are installed at correct positions. Note the size symbol stamped on each jet for identification.

Main air jet (primary) : #70
Pilot jet (primary) : #55
Pilot jet (secondary) : #70

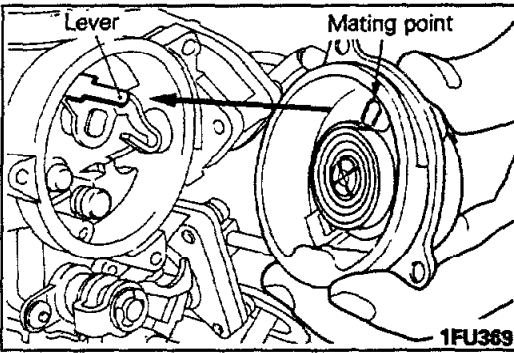
**29. INSTALLATION OF BIMETAL ASSEMBLY**

(1) Fit the bimetal end over the choke valve lever.

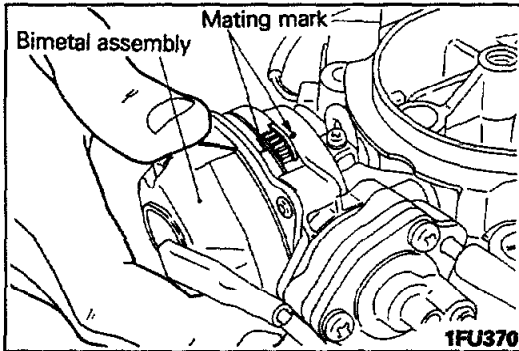

(2) Install the plate and temporarily tighten the screw.
 (3) Align the mating marks.

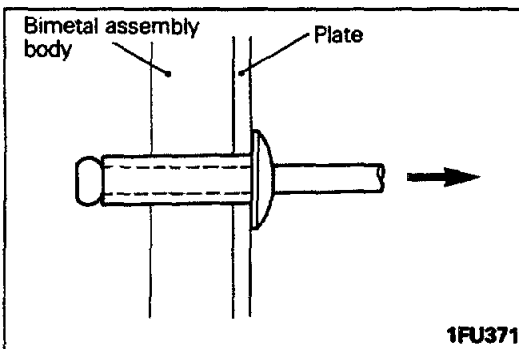

(4) Set the rivet as illustrated.

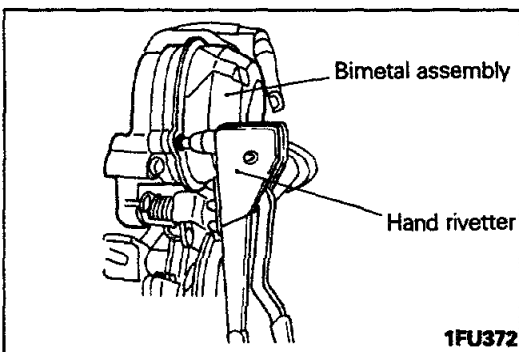

(5) Install the bimetal assembly using a hand rivetter or similar tool with the mating marks aligned correctly.
 (6) Tighten the screw.

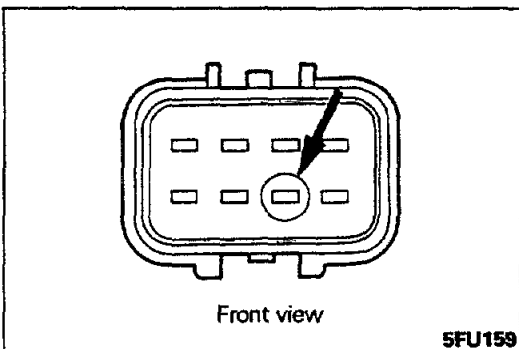

(7) Install terminal to the connector at correct position.

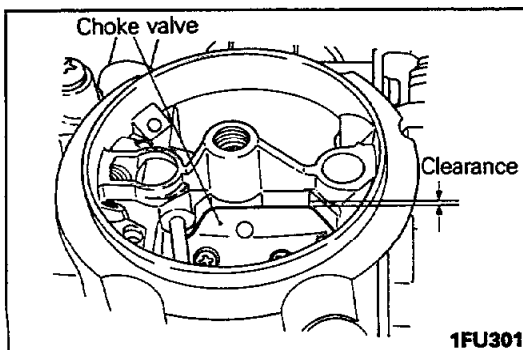
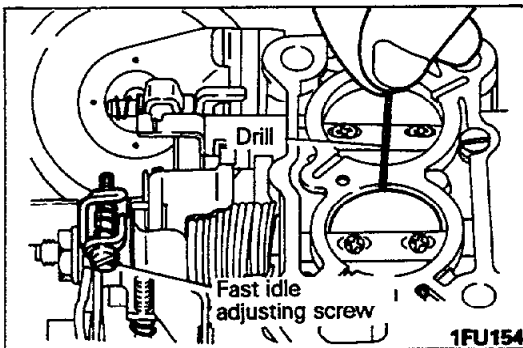
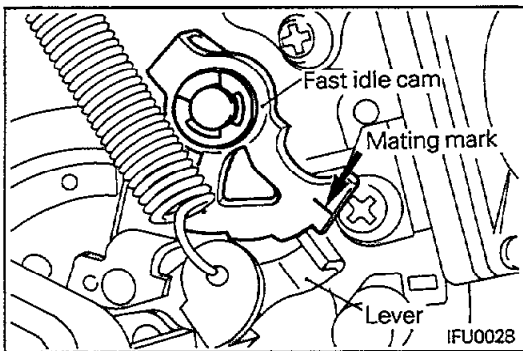
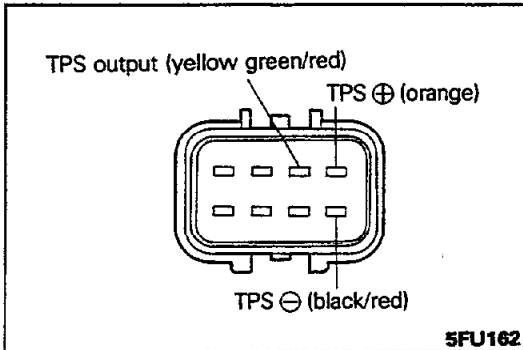
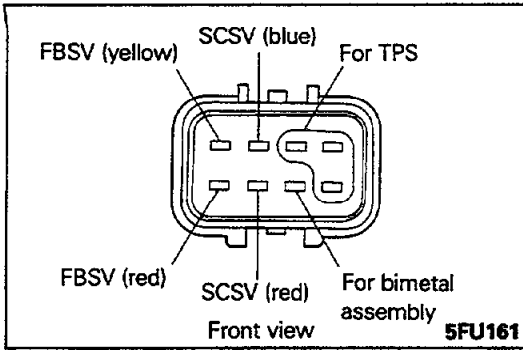

25. INSTALLATION OF SLOW CUT SOLENOID VALVE/20.FEEDBACK SOLENOID VALVE

Install terminals to the connector at correct positions.

10. INSTALLATION OF FLOAT CHAMBER COVER ASSEMBLY

- (1) After installing the float chamber cover, install the throttle position sensor terminals (3) to the connector, paying close attention to their positions.

INSPECTION AND ADJUSTMENT AFTER ASSEMBLY

N14MIABb

FAST IDLE OPENING

- (1) Set lever on the second highest cam of the fast idle cam.
- (2) Measure the primary valve to throttle bore clearance.

Standard value : 0.80 mm (.031 in.)

- (3) If the clearance is out of specification, adjust using the fast idle adjusting screw for the standard value.

NOTE

Adjusting screw direction of rotation vs. idle rpm

Adjusting screw	Valve opening	Fast idle rpm
Clockwise	Larger	Increases
Counter clockwise	Smaller	Decreases

UNLOADER OPENING

N14MIBA

- (1) Lightly press the choke valve with a finger to fully close it.
- (2) In this state, fully open the throttle valve and measure the choke valve to choke bore clearance.

Standard value : 1.9-2.1 mm (.075-.083 in.)

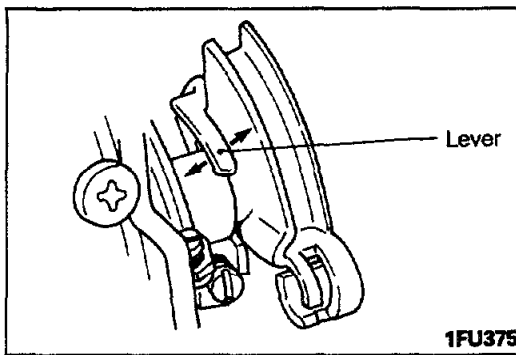

(3) If the clearance is out of specification, bend the throttle lever at illustrated portion to adjust the clearance to the standard value.

NOTE

Lever bending direction	Clearance	Remarks
Up	Larger	Poor response
Down	Smaller	Lower output Plug likely to get sooty

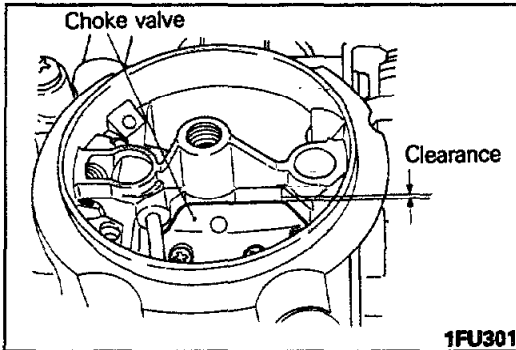

CHOKE BREAKER

N14MICB

Caution

Check and adjust with the bimetal assembly removed.

- (1) Lightly press the choke valve with a finger to fully close it.
- (2) Push the choke breaker rod toward the diaphragm and measure the choke valve to choke bore clearance.

Standard value :

1st stage : 2.3-2.5 mm (.091-.098 in.)

2st stage : 3.0-3.2 mm (.118 -.126 in.)

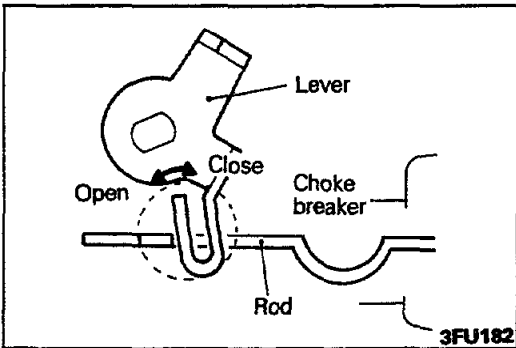

(3) If the clearance is out of specification, adjust by bending the choke lever at illustrated portion.

NOTE

Lever bending direction	Clearance	Remarks
Open	Larger	Poorer startability, more likely to stall
Close	Smaller	Plug likely to get sooty

CHOKE VALVE OPERATION

N14MIDA

- (1) Operate the choke valve with a finger and check for play, incorrect operation and binding.
- (2) If the choke fails to operate smoothly and lightly, wash around the choke valve.
- (3) If the play is excessively large, replace the float chamber cover.

SECONDARY THROTTLE VALVE OPERATION

N14MIEA

- (1) Fully open the throttle valve and operate the secondary throttle valve lever with a finger to check for play, incorrect operation and binding.
- (2) If it fails to operate smoothly and lightly, wash and apply thin coat of engine oil to the shaft.
- (3) If the play is excessively large, replace the throttle body.

PORTS

N14MIFA

- (1) Connect a hand vacuum pump to each port and check for clogging of the passage.
- (2) If there is clogging, clean the port and then blow compressed air into the port.

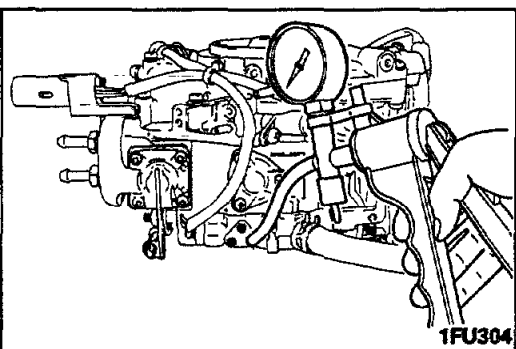

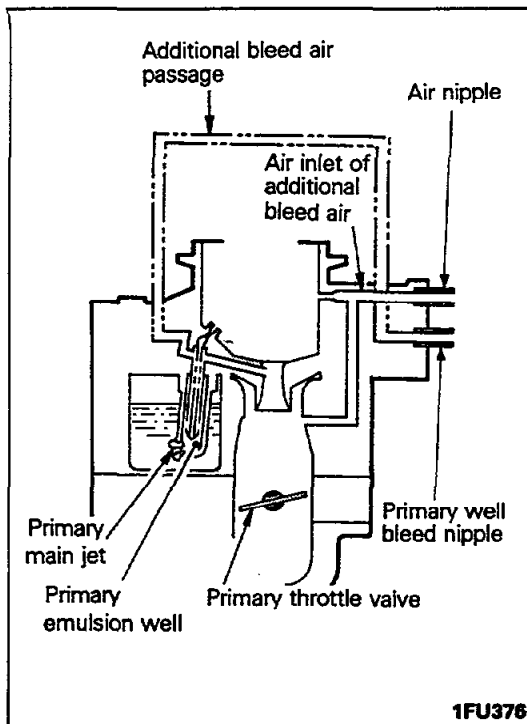

INSPECTION OF HAC BLEED AIR PASSAGE

N14MIGBa

Inspection for Clogging of Primary Well Bleed Nipple – Federal/California and High-altitude vehicles for Federal

- (1) Connect a hand vacuum pump to the nipple.
- (2) Apply vacuum to see that vacuum leaks and does not build up.
- (3) If vacuum builds up, disassemble and check the carburetor as incorrect installation of gasket etc. is suspected.

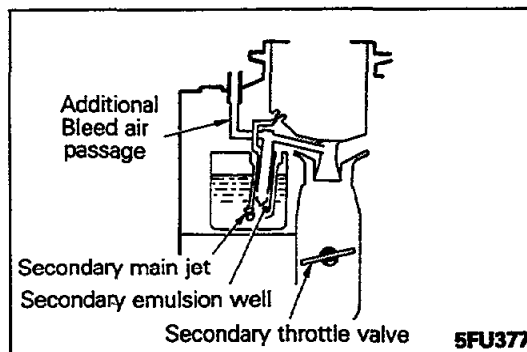

Inspection for Clogging of Secondary Well Bleed Nipple – High-altitude vehicles for Federal

N14MIIBa

- (1) Connect a hand vacuum pump to the nipple.
- (2) Apply vacuum to see that vacuum leaks and does not build up.
- (3) If vacuum builds up, disassemble and check the carburetor as incorrect installation of gasket etc. is suspected.

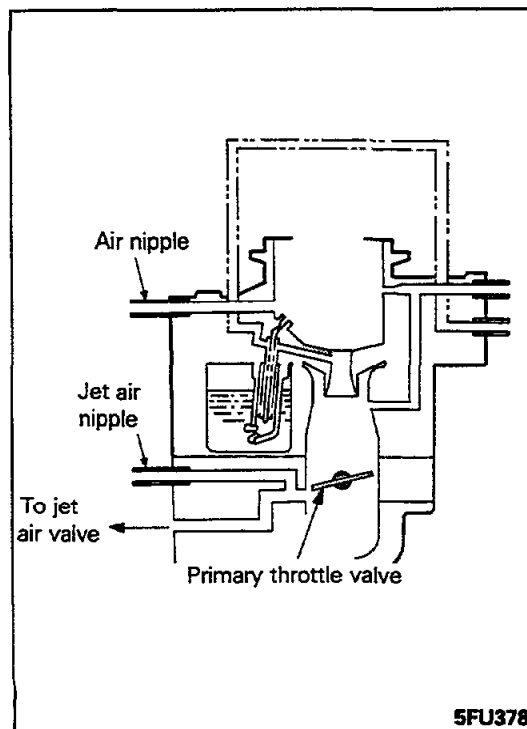

Inspection for Clogging of Jet Air Nipple – High-altitude vehicles for Federal

N14MIIBa

- (1) Connect a hand vacuum pump to the nipple.
- (2) Apply vacuum to see that vacuum leaks and does not build up.
- (3) If vacuum builds up, disassemble and check the carburetor as incorrect installation of gasket etc. is suspected.

FUEL PUMP

N14HA-

REMOVAL AND INSTALLATION

Removal steps

- ◄►►► 1. Air cleaner
- ◄► 2. Connection for the main hose
- ◄► 3. Connection for the return hose
- ◄►►► 4. Fuel pump
- 5. Gasket
- 6. Insulator

- (1) Reverse the removal procedures to reinstall.
- (2) ◄► : Refer to "Service Points of Removal".
- (3) ►► : Refer to "Service Points of Installation".
- (4) **N** : Non-reusable parts.

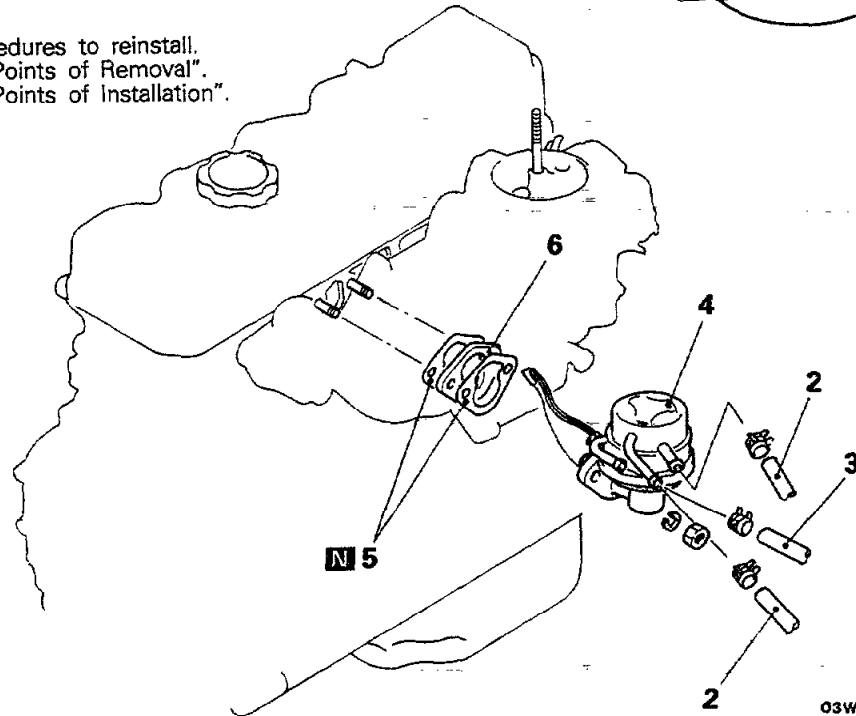
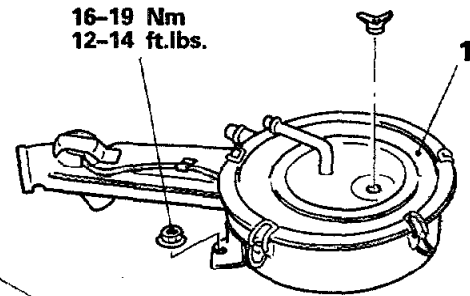

03W551

SERVICE POINTS OF REMOVAL

N14HBACb

1. REMOVAL OF AIR CLEANER

Refer to GROUP11 – Air_cleaner.

2. DISCONNECTION OF MAIN HOSE/3. RETURN HOSE

Before disconnection of the fuel hose, remove the fuel tank cap to lower the pressure in the fuel tank.

4. REMOVAL OF FUEL PUMP

- (1) Turn the crankshaft to place No. 1 cylinder at top dead center on compression stroke.

NOTE

The above operation places the lift of fuel pump stroke at the minimum position, resulting in ease of fuel pump removal.

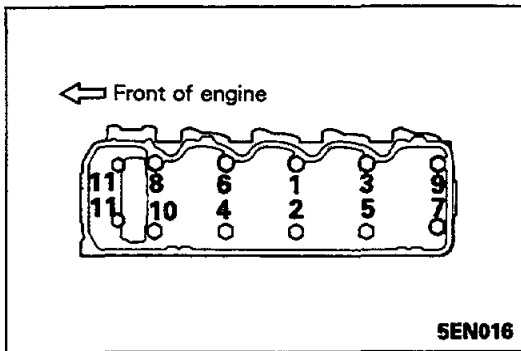
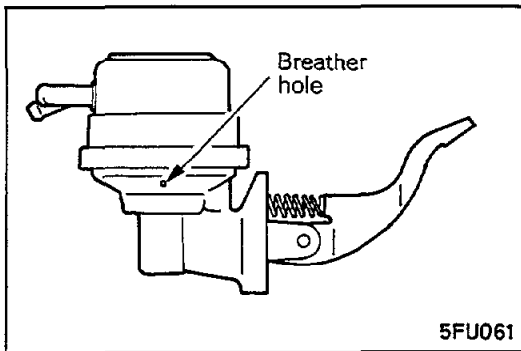
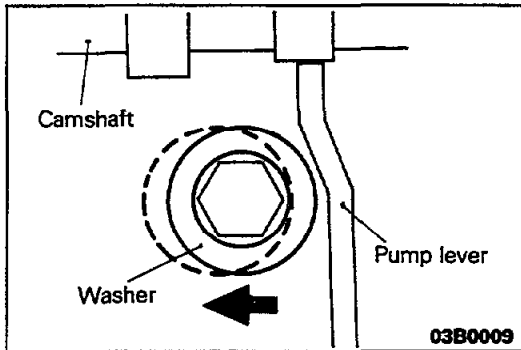
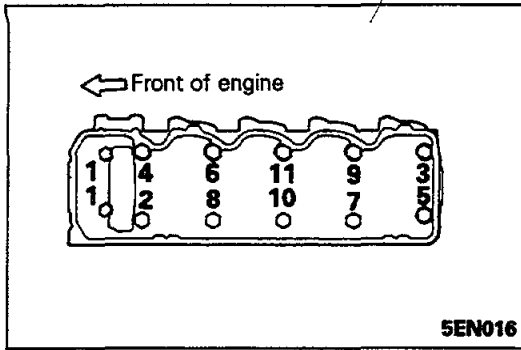

(2) If interference of pump lever occurs in the cylinder head, the washer on the cylinder head bolt may be interfering with the pump lever. Therefore, proceed as follows:

- ① Remove the rocker cover.
- ② Loosen cylinder head bolts in the sequence shown in the illustration.
- ③ Move the washer interfering with the pump lever in the direction shown in the illustration and remove the fuel pump.

INSPECTION

N14HCAC

FUEL PUMP

Make the following checks and replace as necessary. Note that the fuel pump is non-maintainable assembly and must be replaced as an assembly.

- Oil or fuel leaks from breather hole
- Damage, cracks on parts
- Rocker arm for wear

SERVICE POINTS OF INSTALLATION

N14HDACa

4. INSTALLATION OF FUEL PUMP

- (1) Make sure that piston in No. 1 cylinder is in the top dead center on compression stroke.
- (2) If the washer is moved after loosening of cylinder head bolt, proceed to the following items.
 - ① Reinstall the washer in position.
 - ② Tighten the cylinder head bolts to specified torque in the sequence shown in the illustration.
 - ③ Install the rocker cover.

1. INSTALLATION OF AIR CLEANER

Refer to GROUP 11 – Air cleaner.

FUEL TANK

REMOVAL AND INSTALLATION

N14GA-A

Pre-removal Operation

- Draining of the Fuel.

Post-installation Operation

- Supplying of the Fuel.

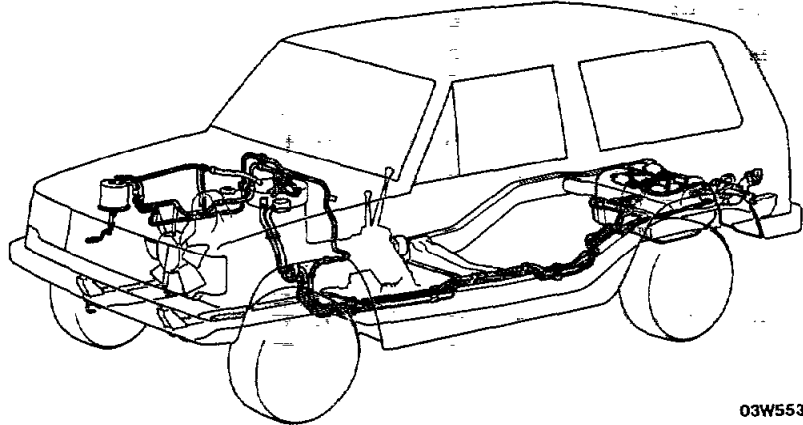

03W553

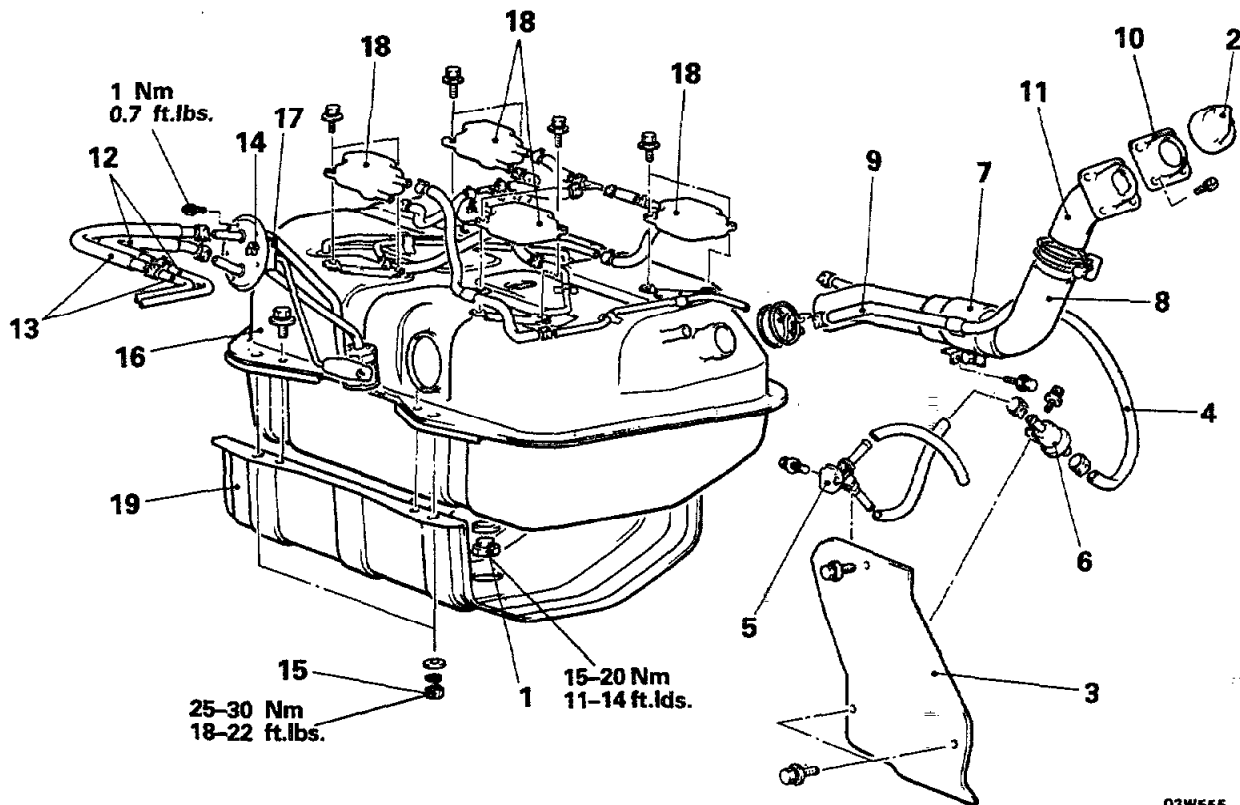

03W555

Removal steps

1. Drain plug
2. Fuel filler cap
3. Fuel filler hose protector
- ◆◆ 4. Vapor hose
- ◆◆ 5. Check valve
6. Overfill limiter (Two-way valve)
7. Clamp assembly
- ◆◆ 8. Fuel filler hose
- ◆◆ 9. Breather hose
10. Packing
11. Fuel filler neck
- ◆◆ 12. Main hose
- ◆◆ 13. Return hose
14. Fuel gauge unit connector connection
15. Fuel tank assembly mounting nuts
16. Fuel tank
17. Pipe assembly
18. Separator tanks
19. Fuel tank protector

NOTE

- (1) Reverse the removal procedures to reinstall.
- (2) ◆◆ : Refer to "Service Points of Installation".

INSPECTION

N14GCAG1

- Check the hoses and the pipes for crack or damage.
- Check the fuel tank cap for malfunction.
- Check the fuel tank for deformation, corrosion or crack.
- Check the fuel tank for dust or foreign material.

NOTE

If the inside of the fuel tank is to be cleaned, use any one of the following:

- (1) Kerosene
- (2) Trichloroethylene
- (3) A neutral emulsion type detergent

- Check the in-tank fuel filter for damage or clogging.
- Check the check valve for malfunction.

CHECKING OVERFILL LIMITER (TWO-WAY VALVE)

A simple way of inspection, however, may be adopted in which the overfill limiter is removed and then air is lightly blown into either the inlet or outlet. If the air passes after a slight resistance, overfill limiter is in good condition.

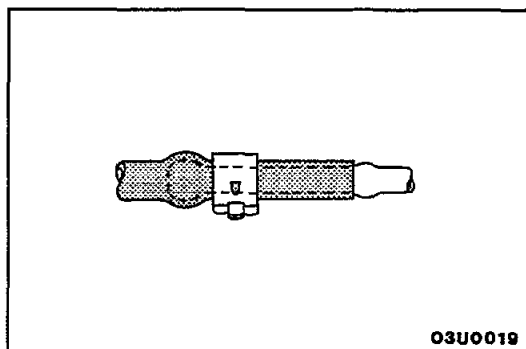
**SERVICE POINTS OF INSTALLATION**

N14GDAE

13. INSTALLATION OF RETURN HOSE/12. MAIN HOSE/4. VAPOR HOSE

When attaching the hoses to the pipes, be sure that the hose is attached until its end comes in touch with the bulge of the pipe as shown in the illustration.

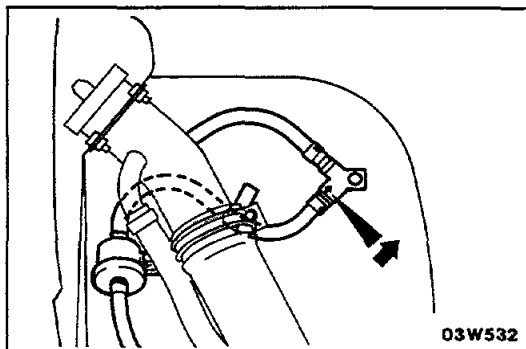
**9. INSTALLATION OF BREATHER HOSE/8. FUEL FILLER HOSE**

Insert the hoses until their ends contact the fuel tank.

5. INSTALLATION OF CHECK VALVE

Install the check valve to the fuel filler hose protector so that the check valve's arrow faces as shown in the figure.

**FUEL LINE AND VAPOR LINE
REMOVAL AND INSTALLATION**

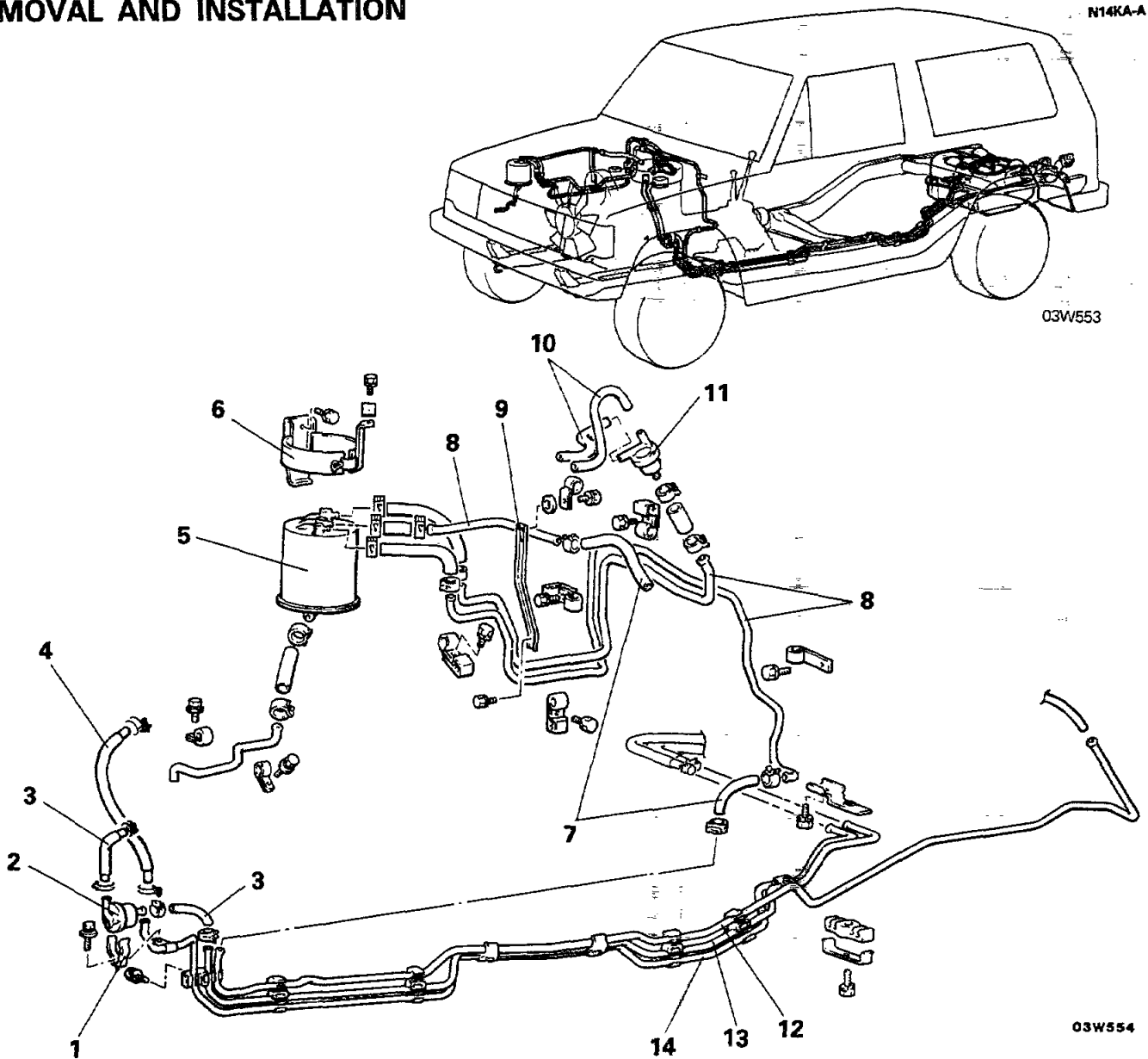

- | | |
|----------------------|-------------------------|
| 1. Fuel filter clamp | 10. Fuel purge hose |
| 2. Fuel filter | 11. Purge control valve |
| ◆◆ 3. Main hose | 12. Fuel vapor pipe |
| ◆◆ 4. Return hose | 13. Fuel main pipe |
| 5. Canister | 14. Fuel return pipe |
| 6. Canister holder | |
| ◆◆ 7. Vapor hose | |
| 8. Fuel vapor pipe | |
| 9. Stay | |

NOTE

◆◆ : Refer to "Service Points of Installation".

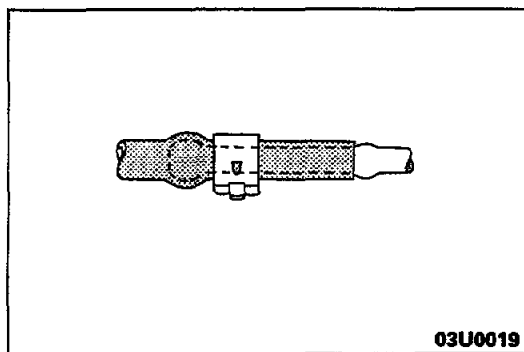
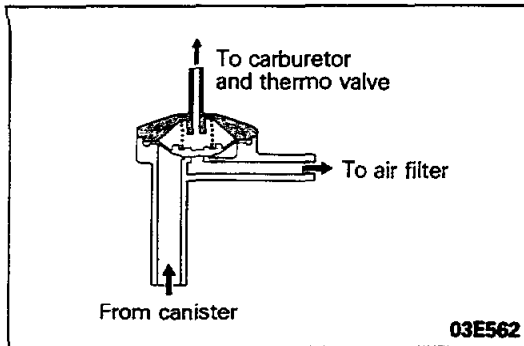

INSPECTION

N14KCABa

- Check the fuel hoses and pipes for cracks, bends, deformation, deterioration or clogging.
- Check the fuel filter for clogging or damage.
- Check the canister for clogging or damage.

CHECKING PURGE CONTROL VALVE

- (1) Make sure that the cooling water is at a temperature between 80 and 90°C (180 and 190°F).
- (2) Disconnect the purge control hose from the air cleaner and blow into the purge hose. If the valve is not open, its operation is normal. Then start the engine and increase the engine speed to 1,500 to 2,000 rpm and blow into the purge hose. If the valve is not open, check for clogged or broken vacuum hose, or malfunctioning thermo valve.

SERVICE POINTS OF INSTALLATION

N14KDAD

7. INSTALLATION OF VAPOR HOSE/4. RETURN HOSE/3. MAIN HOSE

When attaching the hose to the pipes, be sure that the hose is attached until its end comes in touch with the bulge of the pipe as shown in the illustration.