

Remarks

- (1) The broken lines are applicable to models equipped with an automatic transmission.
- (2) For information concerning the ground points (example: ) refer to P.8-14.
- (3) The symbols ①, ② etc. indicate that the wiring is connected (using the same numerical symbol) to the facing page.  
(In other words, ① on the right page is connected to ① on the left page.)

37W681

**BACKUP LIGHTS**

**OPERATION**

- When the gearshift lever is moved to "R" position, with the ignition switch turned to "ON", the backup light switch (manual transmission vehicles) or inhibitor switch (automatic transmission vehicles) is closed, allowing current to flow through fuse No. 4 (manual transmission vehicles), 3 (automatic transmission vehicles), backup light switch or inhibitor switch, backup lights, and ground. This causes the backup lights to go on.

**TROUBLESHOOTING HINTS**

- Only one backup light does not go on
  - Check bulb
- Backup light fail to go off
  - Check backup light switch. – Manual transmission vehicles.
  - Check inhibitor switch. – Automatic transmission vehicles.

## INSTRUMENT PANEL ILLUMINATION

## CIRCUIT DIAGRAM

&lt;2.6L Engine&gt;

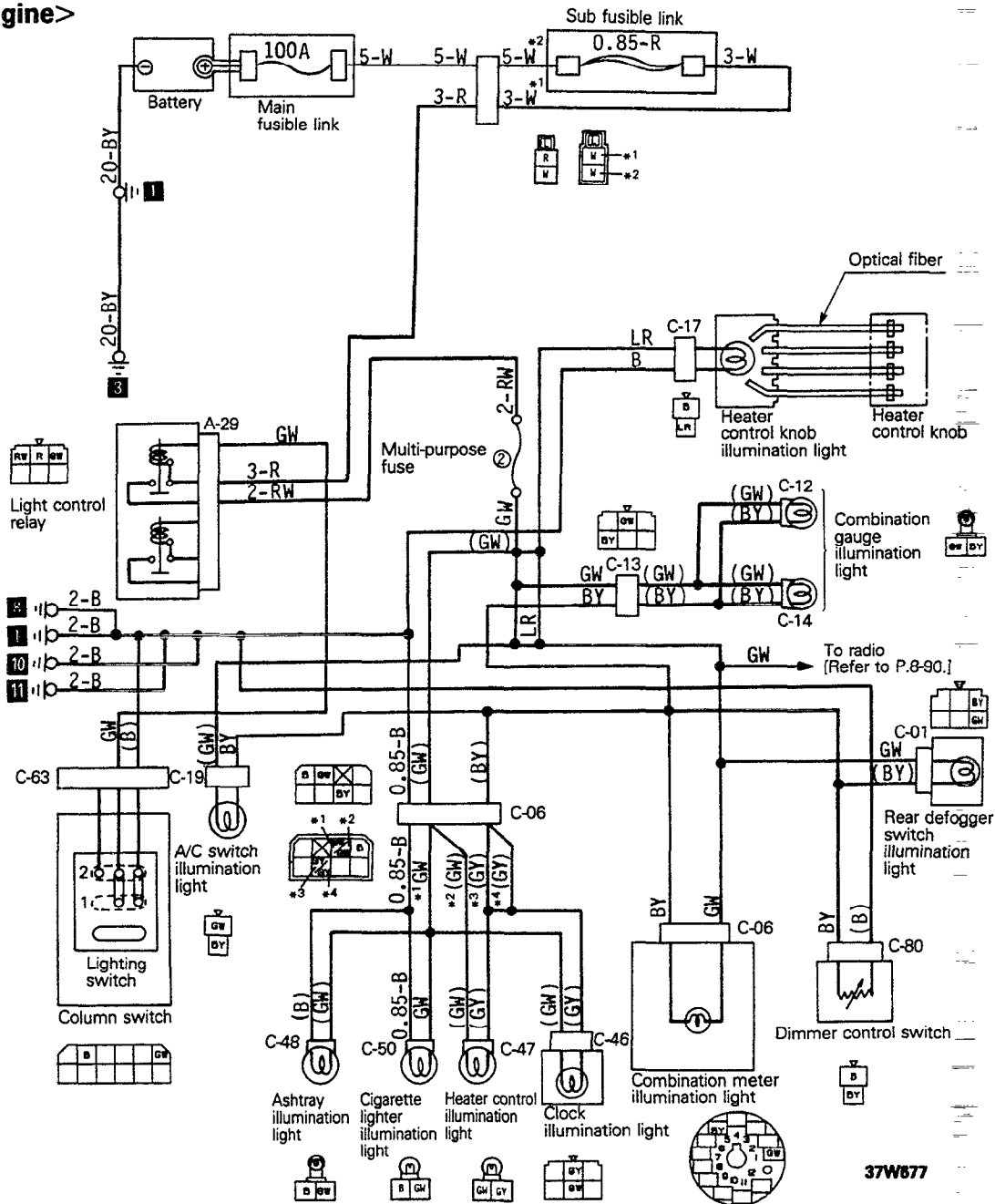

## Remarks

- (1) The broken lines are applicable to models equipped with an automatic transmission.
- (2) For information concerning the ground points (example: ■), refer to P.8-12, 14.

## OPERATION

- Battery voltage is always applied, through the light-control relay, to the lighting switch.
- When the lighting switch is at "1" or "2" position, current flows through light control relay (contacts) fuse No. 2, each illumination light, dimmer control switch (partial circuit), and ground, causing the illumination lights to go on.

## TROUBLESHOOTING HINTS

1. Only one light does not come on.
  - Check bulb.
2. Lights cannot be dimmed.
  - Check dimmer control switch.

37W677

<3.0L Engine>

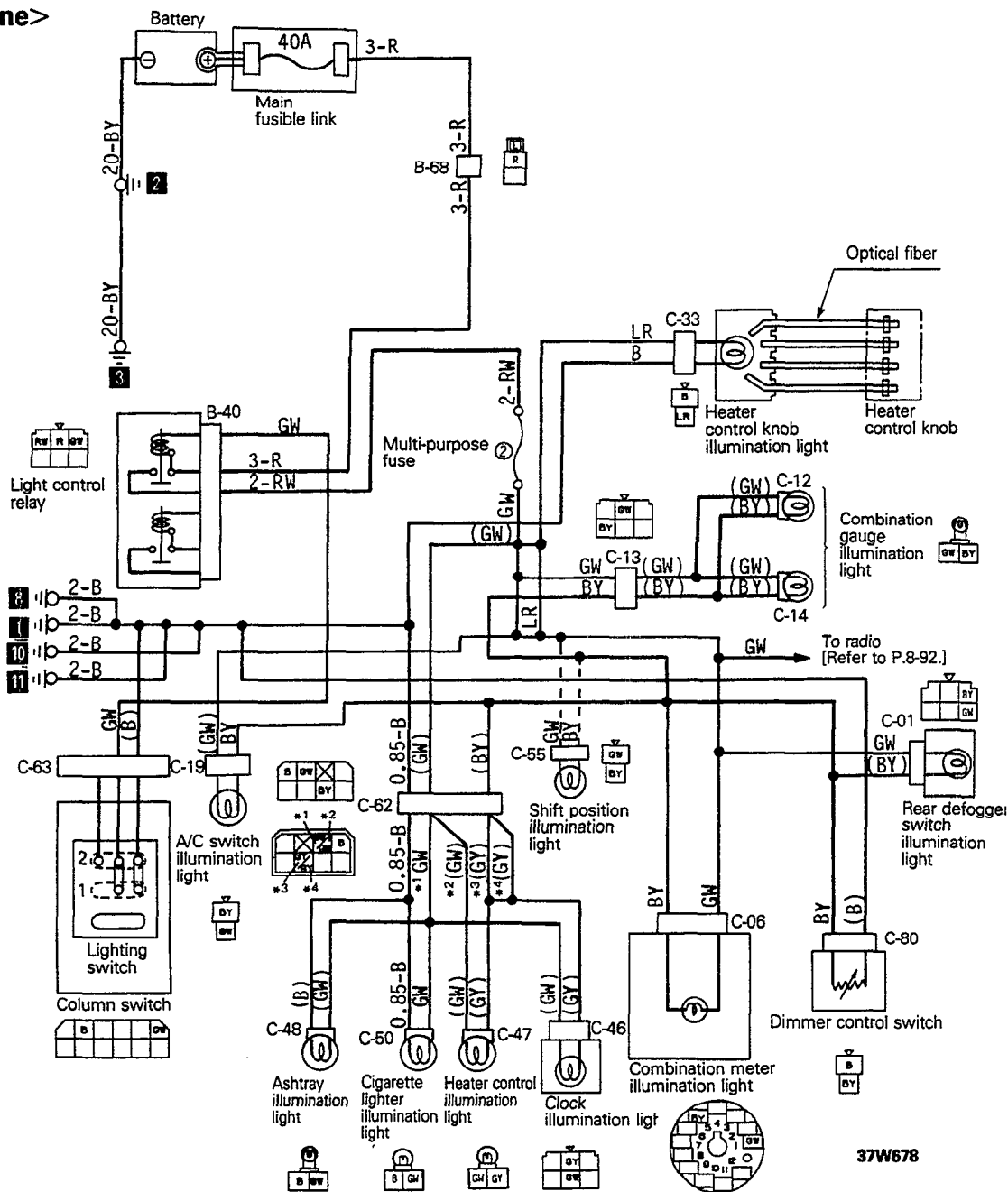

37W678

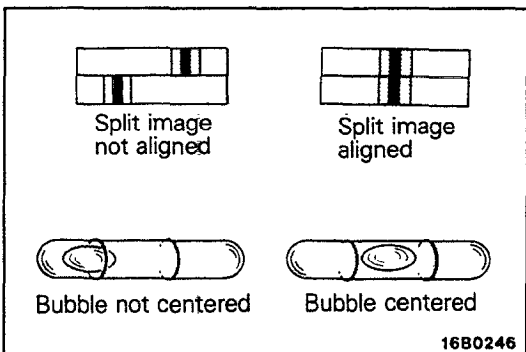
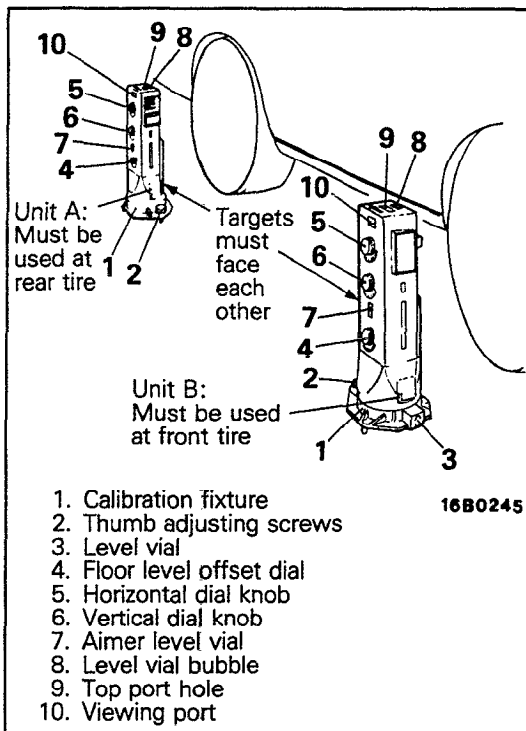

## SERVICE ADJUSTMENT PROCEDURES

### HEADLIGHT AIMING

NO81LAD

#### PRE-AIMING INSTRUCTIONS

1. Test dimmer switch operation.
2. Observe operation of high beam indicator light mounted in instrument cluster.
3. Inspect for badly rusted or faulty headlight assemblies. These conditions must be corrected before a satisfactory adjustment can be made.
4. Place vehicle on a level floor.
5. Jounce front suspension through three (3) oscillations by applying body weight to hood or bumper.
6. Inspect tire inflation.
7. Rock vehicle sideways to allow vehicle to assume its normal position.
8. If fuel tank is not full, place a weight in trunk of vehicle to simulate weight of a full tank [3 kg (6.5 lbs.) per gallon].
9. There should be no other load in the vehicle other than driver or substituted weight of approximately 70 kg (150 lbs.) placed in driver's position.
10. Thoroughly clean headlight lenses.
11. Adjust headlights by following the instructions for the headlight tester manufacturer.

#### LUMINOUS INTENSITY MEASUREMENT

Measure the luminous intensity of headlights with a photometer in accordance with the instruction manual prepared by the manufacturer of the photometer and make sure that the luminous intensity is within the following limit.

Luminous intensity at the center of high intensity zone for high beam.

**Limit: 20,000 cd or more**

#### NOTE

1. When measuring the luminous intensity of headlight, keep the engine at 2,000 rpm and have the battery charged.
2. If there are specific regulations for luminous intensity of headlights in the region where the vehicle is operated, make sure that the intensity conforms to the requirements of such regulations.

# HEADLIGHT

## REMOVAL AND INSTALLATION

N08LIAE

**Post-installation operating**  
 • Adjustment of Headlight Aiming  
 (Refer to P. 8-198.)

### Removal steps

1. Radiator grille
2. Front combination light
3. Headlight bezel
4. Retaining ring
5. Headlight

**NOTE**  
 Reverse the removal procedure to reinstall.

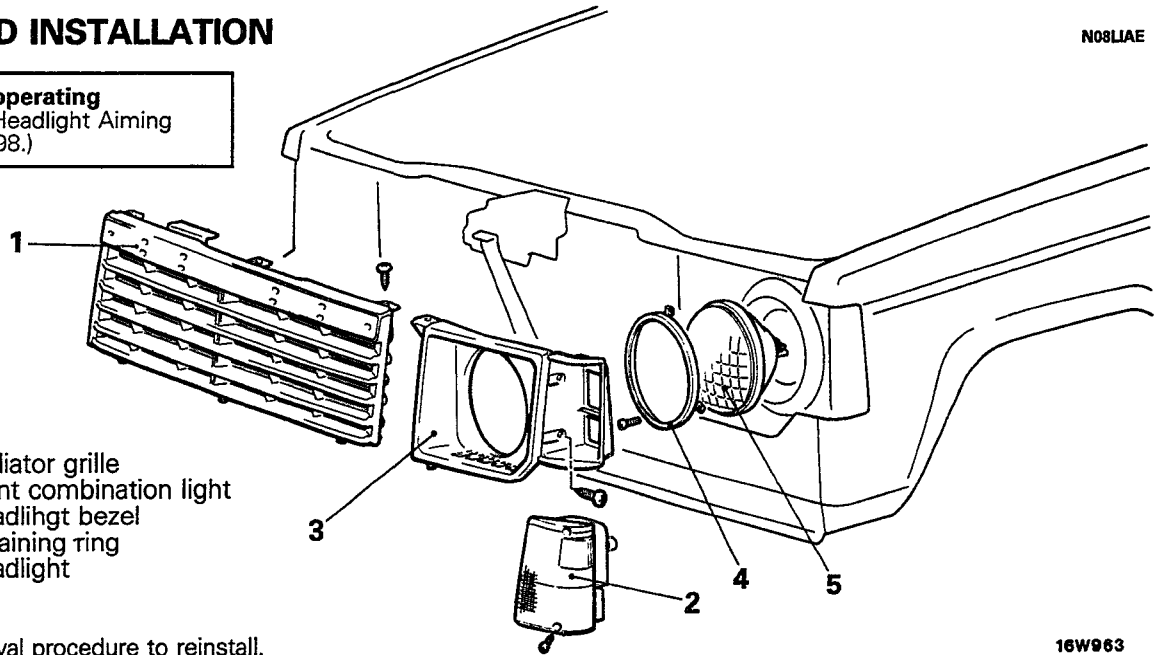

16W963

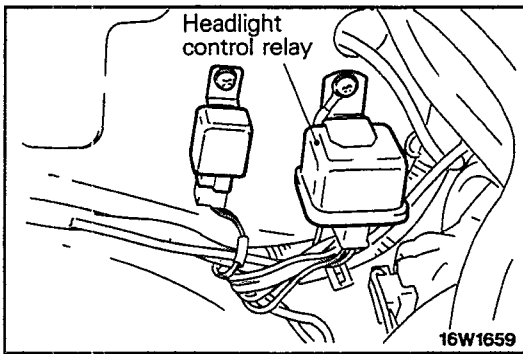

16W1659

## INSPECTION

### HEADLIGHT CONTROL RELAY

Remove the headlight control relay from the inner side of the left fender shield.  
 For models equipped with headlight washers, remove the headlight washer tank, and then remove the headlight control relay.

Check for continuity between the terminals while power is being supplied and while it is not.

Terminal	1	2	3	4	5	6	7
Battery voltage not applied	○—○					○—○	
Battery voltage applied	⊖—⊕	○—○		○—○		⊖—⊕	

**NOTE**

- (1) ○—○ indicates that there is continuity between the terminals.
- (2) ⊖—⊕ indicates the connection with the power supply.

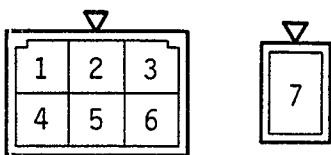

16W896

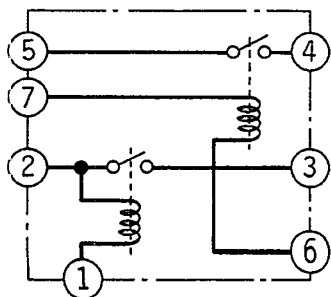

16W897

TSB Revision

right

**COLUMN SWITCH**

**REMOVAL AND INSTALLATION**

N08PAGa

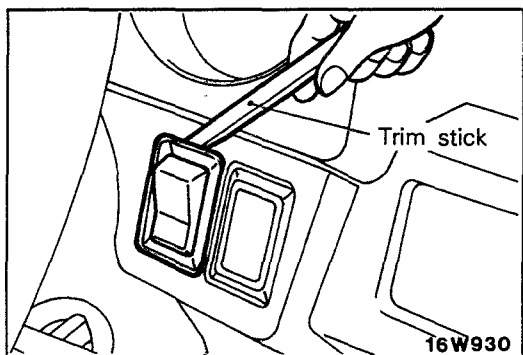
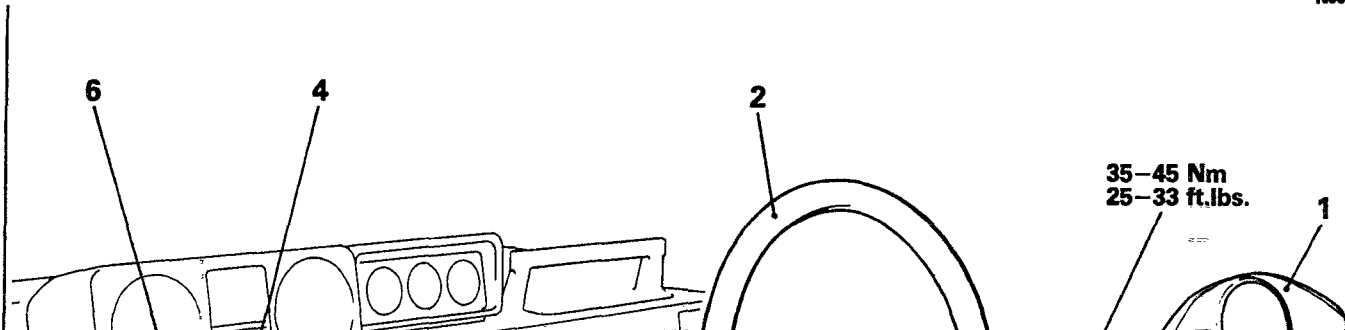

**SERVICE POINTS OF REMOVAL**

**1. HAZARD WARNING SWITCH**

Insert the trim stick into the switch and pry the switch to remove it from the instrument panel.

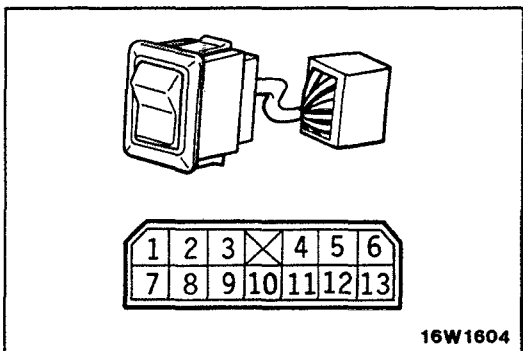

**INSPECTION**

Operate the switch and check the continuity between the terminals.

Terminal Switch position	10	11	4	3	9	12	5	2	8	6	Indicator light	13
OFF			○	○							○	○
ON	○					○	○	○	○	○	○	○

**NOTE**

○—○ Indicates that there is continuity between the terminals.

**DIMMER CONTROL SWITCH**

**REMOVAL AND INSTALLATION**

N08IRAB

**Removal steps**

1. Knob
2. Ring nut
3. Dimmer control switch

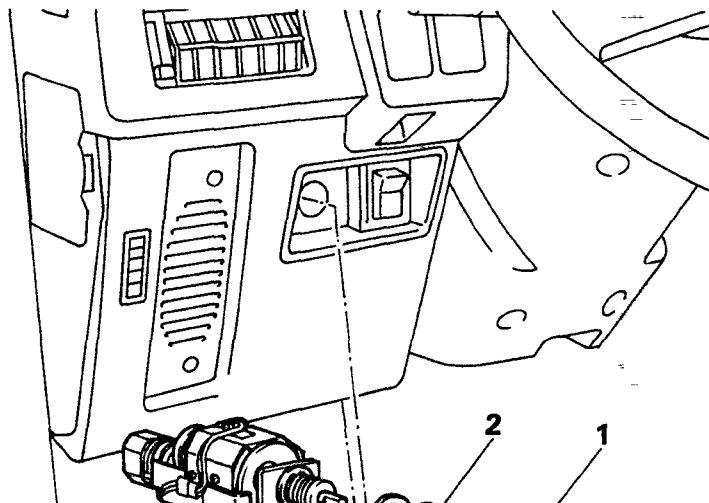

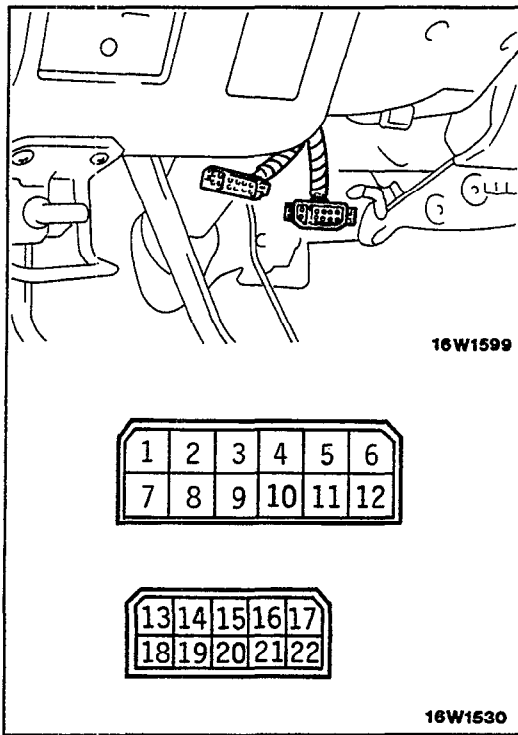

**INSPECTION**

Remove the steering lower column cover, and then detach the connector of the column switch from the wiring harness. Operate the switch and check the continuity between the terminals.

**LIGHTING SWITCH**

Switch position	Terminal	1	7	5
OFF				
☞☛		○—○		○—○
☞☛		○—○	○—○	○—○

**NOTE**

○—○ Indicates that there is continuity between the terminals.

**DIMMER-PASSING SWITCH**

Switch position	Terminal	14	4	10	7
D <sub>1</sub>		○—○			
D <sub>2</sub>		○—○		○—○	
P <sub>1</sub>		○—○	○—○	○—○	○—○
P <sub>2</sub>		○—○	○—○	○—○	○—○

**NOTE**

○—○ Indicates that there is continuity between the terminals.

**TURN SIGNAL SWITCH**

Switch position	Terminal	2	22	21	16
Left		○—○		○—○	○—○
Neutral			○—○	○—○	○—○
Right		○—○		○—○	○—○

**NOTE**

○—○ Indicates that there is continuity between the terminals.

**HAZARD WARNING SWITCH  
REMOVAL AND INSTALLATION**

↔ 1. Hazard warning switch

**NOTE:**

↔ : Refer to "Service Points of Removal".

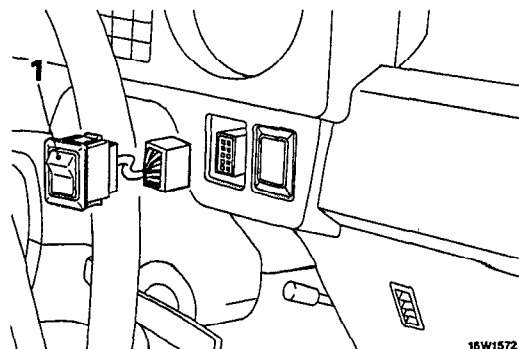

N08CAC

16W1572

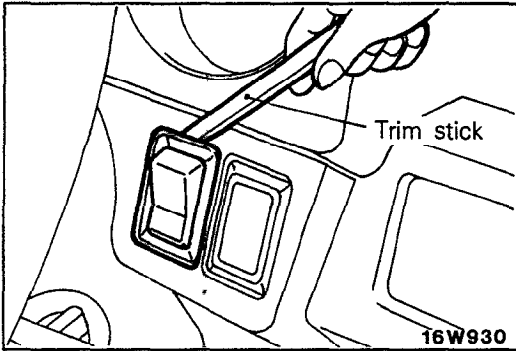

**SERVICE POINTS OF REMOVAL**

**1. HAZARD WARNING SWITCH**

Insert the trim stick into the switch and pry the switch to remove it from the instrument panel.

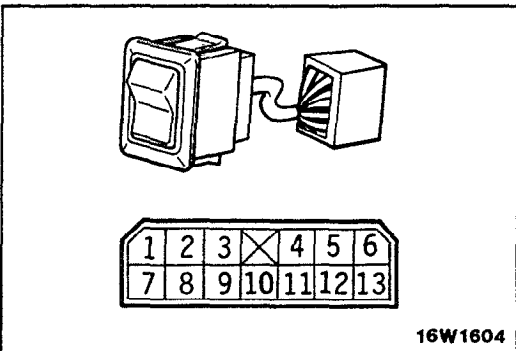

**INSPECTION**

Operate the switch and check the continuity between the terminals.

Terminal Switch position	10	11	4	3	9	12	5	2	8	6	Indi- cator light	13
OFF			○	○							○	○
ON	○					○	○	○	○	○	○	○

**NOTE**

○—○ Indicates that there is continuity between the terminals.

**DIMMER CONTROL SWITCH**

**REMOVAL AND INSTALLATION**

NO81RAB

**Removal steps**

1. Knob
2. Ring nut
3. Dimmer control switch

**NOTE**

Reverse the removal procedures to reinstall.

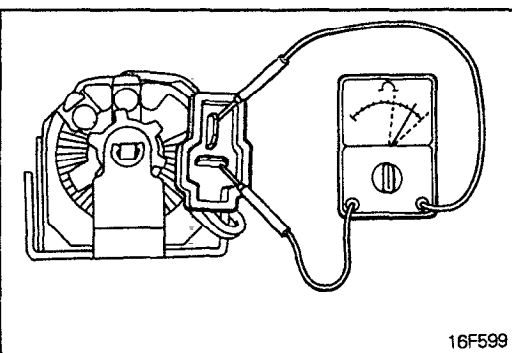
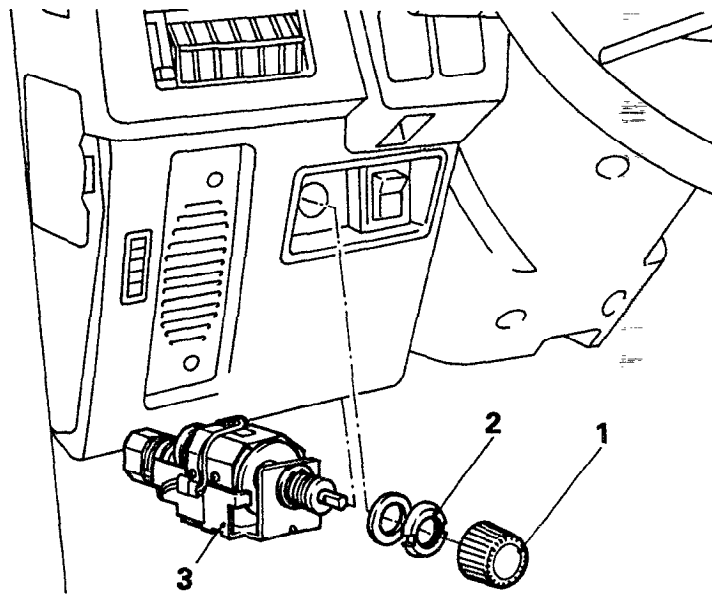

**INSPECTION**

- (1) Measure the continuity between the dimmer control switch terminals with an ohmmeter.
- (2) If the resistance value varies smoothly between 0 and 10Ω throughout the entire operation range, the dimmer control switch is functioning properly.