

METERS AND GAUGES

SPECIFICATIONS

GENERAL SPECIFICATIONS

METERS AND GAUGES

N08HB-

Items	Specifications
Speedometer	
Type	Electromagnetic type
Tachometer	
Type	Pulse type
Detection source	Ignition coil
Fuel gauge	
Type	Bimetal type (voltage limiter incorporated for 7V)
Fuel gauge unit	
Type	Variable resistance type
Engine coolant temperature gauge	
Type	Bimetal type (7V operation)
Engine coolant temperature gauge unit	
Type	Thermistor type
Oil pressure gauge	
Type	Bimetal type
Oil pressure gauge unit	
Type	Bimetal type
Inclinometer	
Type	Gravity type
Damping system	Oil-filled system
Voltage meter	
Type	Bimetal type

INDICATOR AND WARNING LIGHTS

Items	Specifications
Turn signal indicator lights W	1.4 (74)
High beam indicator light W	1.4 (74)
Door-ajar warning light W	1.4 (74)
Fasten seat belt indicator W	1.4 (74)
Brake warning light W	1.4 (74)
Charging warning light W	1.4 (74)
4WD indicator light W	1.4 (74)
Maintenance required warning light W	1.4 (74)
Check engine warning light W	3.4 (158)
A/T oil temperature warning light W	1.4 (74)
Overdrive indicator light W	1.4 (74)
Free-wheeling hub light W	1.4 (74)

NOTE

The values parentheses denote SAE grade numbers.

BUZZER

Items	Specifications
Range of voltage used V	10–16
While buzzing (Terminal voltage at 13V)	
Sound pressure dB	53±7
Fundamental frequency Hz	900±150

SERVICE SPECIFICATIONS

N08HC-

Items	Specifications
Standard values	
Speedometer indication error mph	
20	+2 -1
40	+4 -2
60	+6 -3
80	+8 -4
100	+10 -6
Tachometer indication error rpm	
1,000 rpm	±100
3,000 rpm	±150
5,000 rpm	±250
Fuel gauge resistance value Ω	
Between terminals 1 (power supply) and 2 (fuel gauge unit)	55
Between terminals 2 (fuel gauge unit) and 3 (ground)	165
Between terminals 1 (power supply) and 3 (ground)	110
Fuel gauge unit resistance value Ω	
Float point "F"	1–5
Float point "E"	103–117
Fuel gauge unit float position mm (in.)	
2.6L Engine	
Float point "F"	11–13 (.43–.51)
Float point "E"	180–182 (7.09–7.17)
3.0L Engine (2-door vehicles)	
Float point "F"	9–11 (.35–.43)
Float point "E"	229–231 (9.02–9.09)
3.0L Engine (4-door vehicles)	
Float point "F"	15–17 (.59–.67)
Float point "E"	224–226 (8.82–8.90)
Engine coolant temperature gauge resistance value Ω	
Between terminals 1 (power supply) and 2 (water temperature gauge unit)	55
Oil pressure gauge resistance value Ω	Approx. 50
Voltage meter resistance value Ω	380–460
Voltage meter indication V	
10V	±0.5
16V	±0.5

TROUBLESHOOTING

METER CIRCUIT

N08HHAB

OPERATION

Fuel Gauge

- When the ignition switch is turned to "ON", current flows through fuse No. 3 fuel gauge, fuel gauge unit and ground, in turn operating the fuel gauge.
- When fuel level is high, the fuel gauge unit internal resistance is small so that the current passing through the circuit is relatively large. This causes the gauge pointer to swing towards "F".
- When fuel level becomes low, the unit internal resistance is increased, so only a small current flows the circuit and the gauge pointer swings towards "E".
- Inside the fuel gauge, there is a voltage limiter which functions to maintain a constant output voltage (at 7V) to the gauge units (fuel gauge unit and engine coolant temperature gauge unit).

Engine Coolant Temperature Gauge

- When the ignition switch is turned to "ON", current flows through fuse No. 3, engine coolant temperature gauge, engine coolant temperature gauge unit, and ground, in turn, operating the engine coolant temperature gauge.
- When coolant temperature is high, the gauge unit internal resistance is small so that the current passing through the circuit is relatively large. This causes the gauge pointer to swing towards "H".
- When coolant temperature is low, the unit internal resistance is increased so a small current flows in the circuit, and the gauge pointer swings towards "C".

Oil-pressure gauge

- With the ignition key at the "ON" position, current flows to fuse No. 3, oil-pressure gauge, the Oil-pressure gauge unit, and ground, and the oil-pressure gauge is activated.
- When the oil pressure is high, the contacts (within the unit) close for a long time, with the result that the amount of current flowing through the circuit is great, and the gauge's indicator indicates at the high-pressure area.
- With the oil pressure is low, the contacts (within the unit) open for a short time, with the result that the amount of current flowing through the circuit is low, and the gauge's indicator indicates at the low-pressure area.

Brake Warning Light

- When the ignition switch is turned to "ON" and before the engine starts, current flows through fuse No. 3, brake warning light, alternator and ground. The brake warning light goes on and stays on until the engine starts. The light goes off once the engine starts. Burnt-out bulb check.
- If the brake fluid level falls below the preset level or the parking brake is applied, the brake fluid level sensor switch or the parking brake switch contacts close. This causes current to flow through the brake warning light and brake fluid level sensor or parking brake switch to ground, causing the warning light to go on.

Wiring color code

B: Black Br: Brown G: Green
 Ll: Light blue O: Orange P: Pink

Gr: Gray L: Blue Lg: Light green
 R: Red Y: Yellow W: White

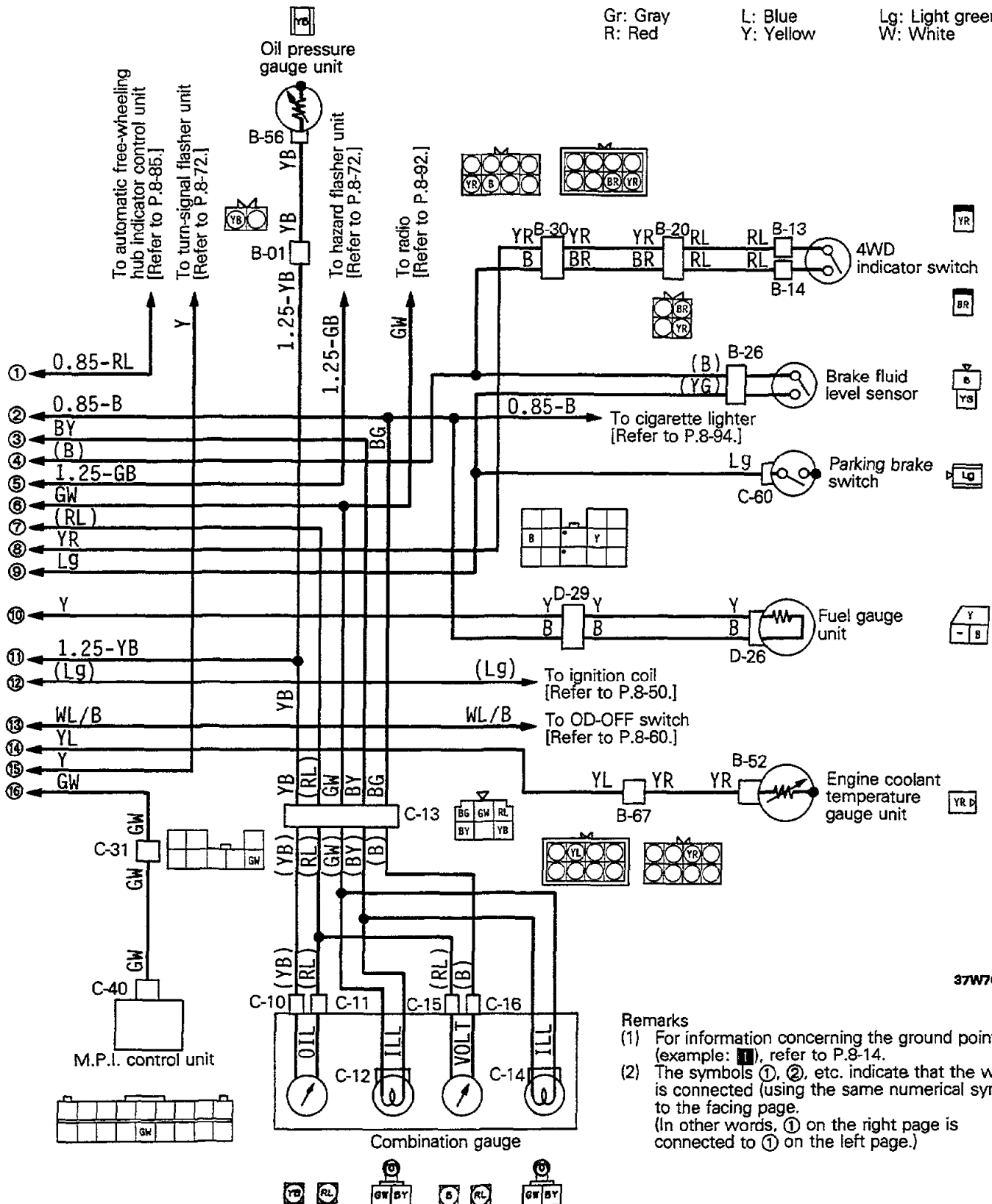

Remarks

- For information concerning the ground points (example: ) refer to P.8-14.
- The symbols ①, ②, etc. indicate that the wiring is connected (using the same numerical symbol) to the facing page. (In other words, ① on the right page is connected to ① on the left page.)

37W700

SERVICE ADJUSTMENT PROCEDURES

SPEEDOMETER INSPECTION

NOSH1LAFa

NOTE

if there is a special regulation for speedometer indicator difference in the area where the vehicle is operated, be sure to meet the requirement of the regulation.

- (1) Adjust tire inflation pressure to the standard value. (Refer to GROUP 22 – General Specifications.)
- (2) Use speedometer tester to check indicator difference.

Caution

When checking with speedometer tester, block nonoperating wheels to prevent vehicle moving.

TACHOMETER INSPECTION <2.6L Engine>

NOSHIBAa

Connect a tach-dwell meter, and then compare the meter readings at various engine speeds with the values indicated on the tachometer.

Standard value:

1,000 rpm	±100 rpm
3,000 rpm	±150 rpm
5,000 rpm	±250 rpm

Caution

The tachometer is the negative-ground type, and therefore should not be connected in reverse polarity to the battery. If the tachometer is connected in reverse polarity, the transistors and diodes will be damaged.

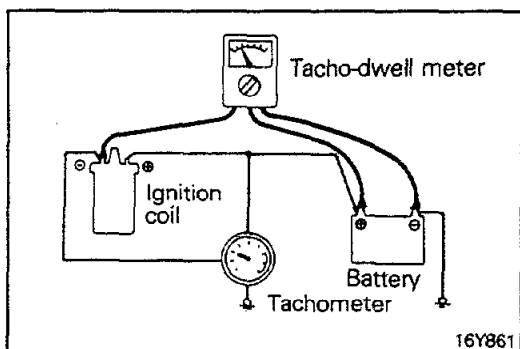

16Y861

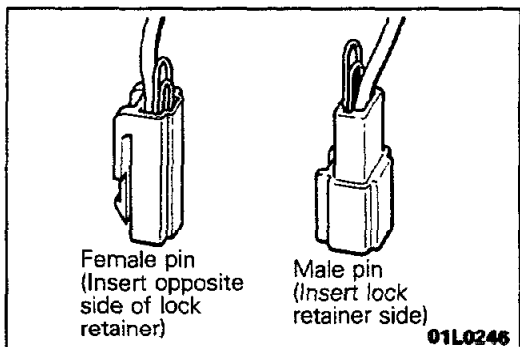

01L0246

TACHOMETER INSPECTION <3.0L Engine>

NOSHIBL

- (1) Insert paper clip on 1 pin connector (from harness side) located between the ignition coil (primary side) and LC filter.

Caution

Insert paper clip along terminal wall as illustrated.

- (2) Connect a tach-dwell meter to paper clip. Compare the tach-dwell meter reading with the tachometer reading at each engine speed and check that the error is within the standard value.

Standard value:

1,000 rpm	±100 rpm
3,000 rpm	±150 rpm
5,000 rpm	±250 rpm

Caution

The tachometer is the negative-ground type, and therefore should not be connected in reverse to the battery. If the tachometer is connected in reverse, transistors and diodes will be damaged.

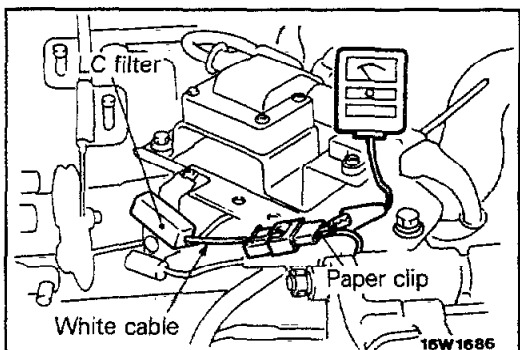

16W1686

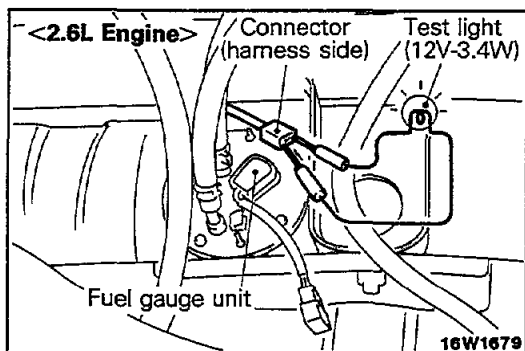

FUEL GAUGE SIMPLE TEST

N08HICK

- (1) Remove connector from fuel gauge unit in fuel tank.
 - (2) Connect test light between yellow and black wires on connector.
 - (3) Turn ON ignition key.
 - (4) Assure test light flashes and gauge needle moves.
 - (5) If test light flashes but gauge needle does not move, replace fuel gauge.
- If test light does not flash (and gauge needle does not move), check fuse for broken wire, or resistance between gauge terminals (see pages 8-174.), or break in harness.

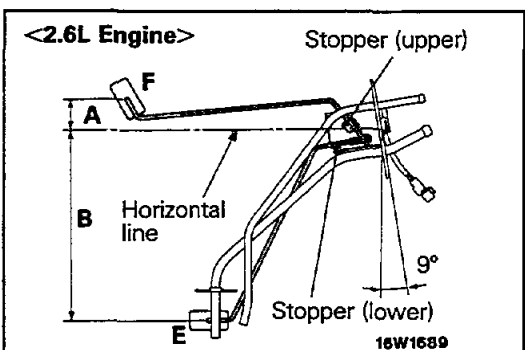
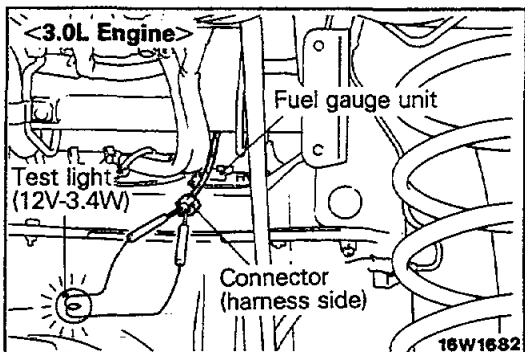

FUEL GAUGE UNIT INSPECTION

N08HIG

To check the fuel gauge unit, remove the unit from the fuel tank. (Refer to GROUP 14 – Fuel Tank.)

FUEL GAUGE UNIT FLOAT POSITION CHECK

Move the float and measure the float position at points “F” and “E” when the float arm contacts the stopper.

Standard value:

- <2.6L Engine>
A 11–13 mm (.43–.51 in.)
B 180–182 mm (7.09–7.17 in.)
- <3.0L Engine (2-door vehicles)>
A 9–11 mm (.35–.43 in.)
B 229–231 mm (9.02–9.09 in.)
- <3.0L Engine (4-door vehicles)>
A 15–17 mm (.59–.67 in.)
B 224–226 mm (8.82–8.90 in.)

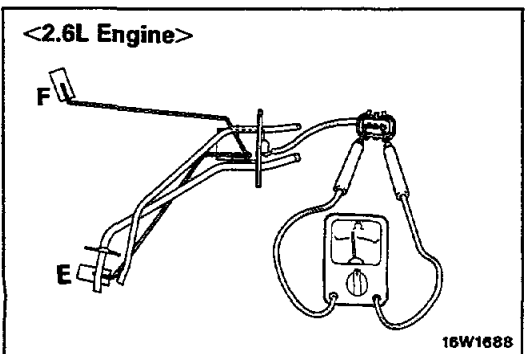
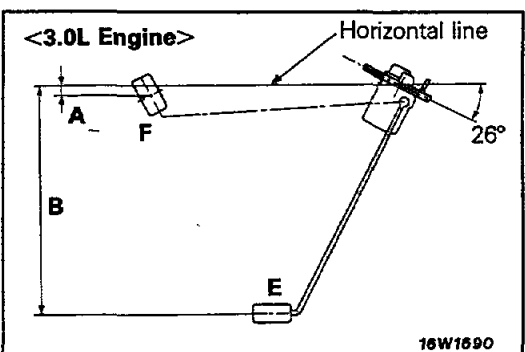

FUEL GAUGE UNIT RESISTANCE CHECK

- (1) Check that the resistance between terminals is within the standard value when the fuel gauge unit float is between positions “F” and “E”.

Standard value:

- Point F 1–5 Ω
Point E 103–117 Ω

- (2) Also check that the resistance changes smoothly when the float is moved to “F” and “E”.

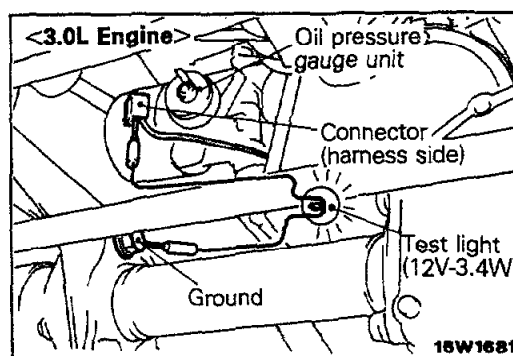
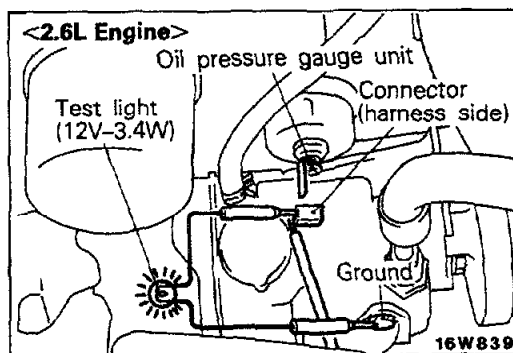
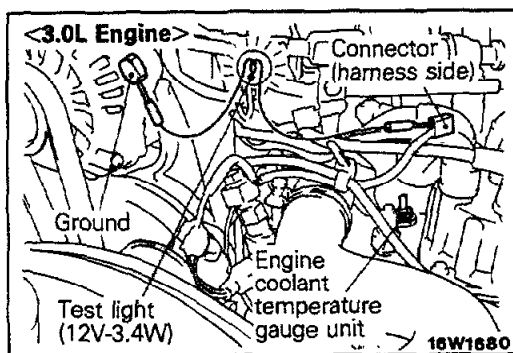
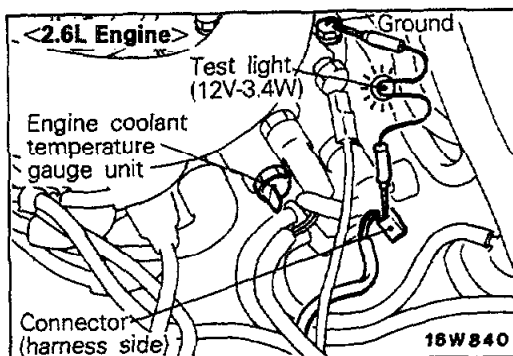
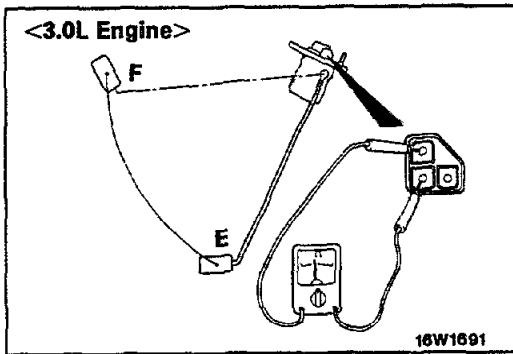

ENGINE COOLANT TEMPERATURE GAUGE SIMPLE TEST

NOSHIDA

- (1) Remove connector from engine coolant temperature gauge unit in engine compartment.
 - (2) Ground harness side connector via test light.
 - (3) Turn ON ignition key.
 - (4) Check that test light flashes and gauge needle moves.
 - (5) If test light flashes but the gauge needle does not move, replace engine coolant temperature gauge.
- If test light does not flash (and gauge needle does not move), check fuse for broken wire, or resistance between gauge terminals (see pages 8-174.), or break in harness.

ENGINE COOLANT TEMPERATURE GAUGE UNIT INSPECTION

NOSHICO

Refer to GROUP 7 – Engine Coolant Temperature Gauge Unit.

OIL PRESSURE GAUGE SIMPLE TEST

NOSHIFA

- (1) Disconnect the wiring connector from the oil pressure gauge unit inside the engine compartment.
 - (2) Ground the connector at the harness through a test light.
 - (3) Turn the ignition key to the ON position.
 - (4) Check to be sure that the test light illuminates steadily and the indicator of the oil pressure gauge moves.
- (5) If both the test light and gauge operate, the circuit to the gauge unit is normal and the gauge unit itself is faulty. If the test light flashes but the gauge does not operate, the gauge is faulty. If neither the test light nor the gauge operates, the oil pressure gauge circuit is faulty.

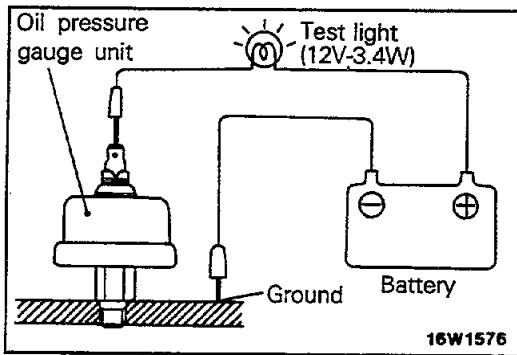

OIL PRESSURE GAUGE UNIT CURRENT CHECK N08H1E

- (1) Disconnect the wiring connector from the oil pressure gauge unit inside the engine compartment.
- (2) Apply battery voltage (through the test light) to the gauge unit side terminal.
- (3) Check to be sure that the test light switches OFF when the engine is stopped, and that it flashes while the engine is running.

VOLTAGE METER SIMPLE TEST N08H1G

- (1) Connect a voltmeter for testing.
- (2) Turn the ignition key to the ON position.
- (3) Compare the readings of the voltmeter for testing and of the vehicle's voltage meter.

Standard value:

10V	±0.5V
16V	±0.5V

**COMBINATION METER
REMOVAL AND INSTALLATION**

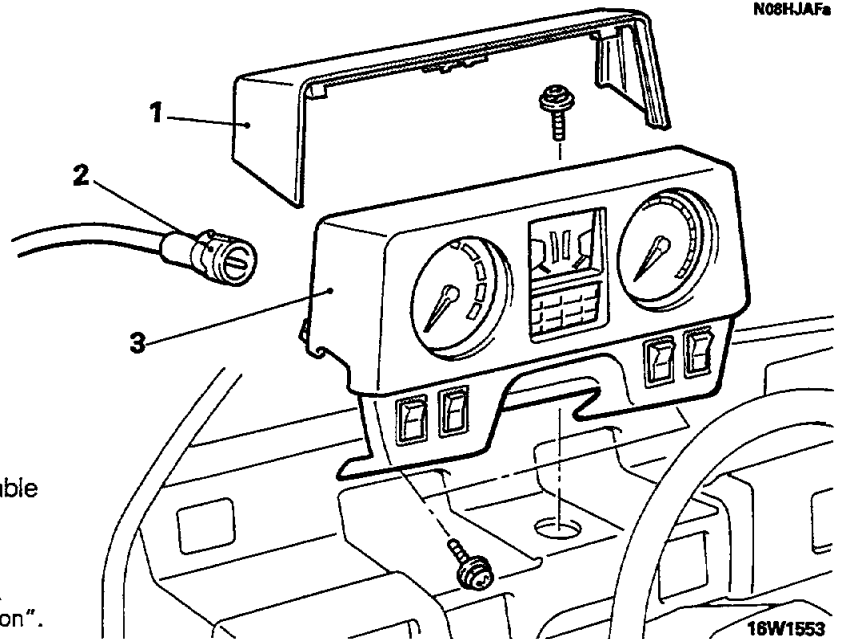

Removal steps

1. Meter cover
2. Connection of speedometer cable
3. Meter assembly

NOTE

- (1) Reverse the removal procedures to reinstall.
- (2) : Refer to "Service Points of Installation".

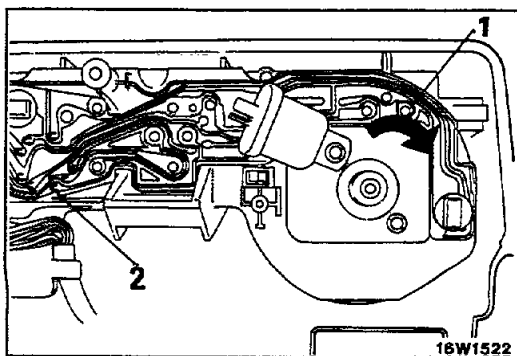

**INSPECTION
REED SWITCH**

Using an ohmmeter, check that continuity and discontinuity alternate between terminals 1 and 2 four times at every rotation of the shaft of the speedometer cable connection.

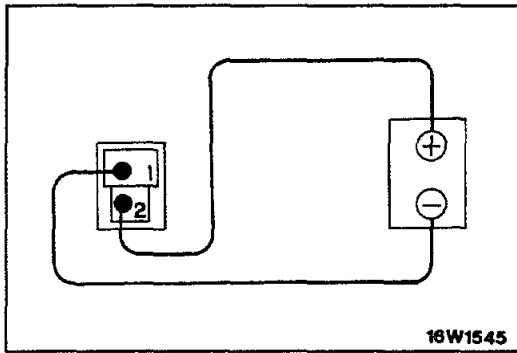
**BUZZER**

Check to be sure that buzzer sounds when the battery's positive (+) terminal is connected to terminal 2 and the battery's negative (-) terminal is connected to terminal 1.

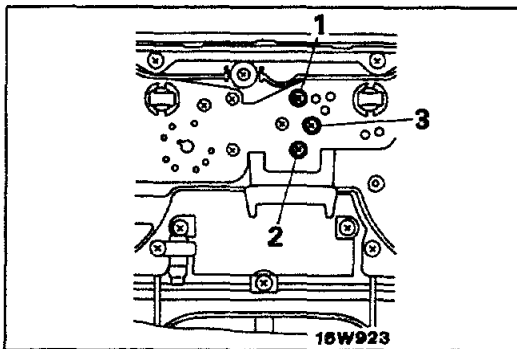
**FUEL GAUGE**

Measure the resistance value between the terminals by using an ohmmeter.

Standard value:

1-2 terminals: 55 Ω

2-3 terminals: 165 Ω

1-3 terminals: 110 Ω

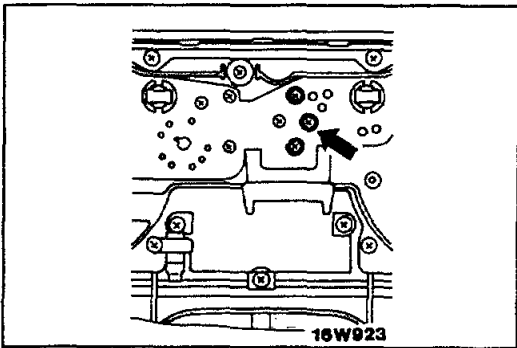
**Caution**

If there is a malfunction of the ground contact of the voltage regulator even once during vehicle operation, the excessive current flowing through the heat coil of the engine coolant temperature gauge and the fuel gauge will cause permanent distortion of the bimetal, resulting in the indications being consistently lower than the actual value.

For this reason, therefore, be sure to make the earth contact securely.

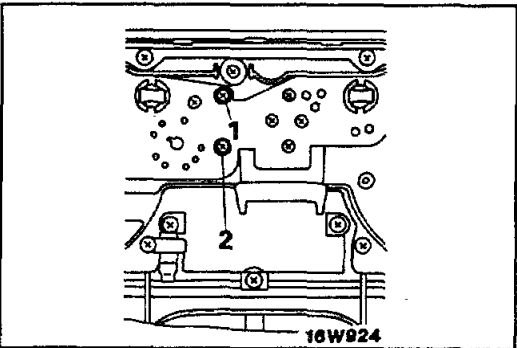
**ENGINE COOLANT TEMPERATURE GAUGE**

Measure the resistance value between the terminals by using an ohmmeter.

Standard value:

Bimetal type

1-2 terminals: 55 Ω

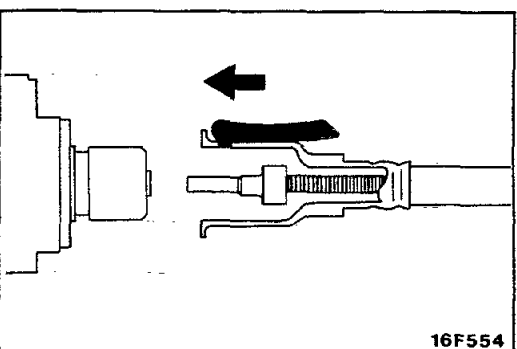
**SERVICE POINTS OF INSTALLATION****2. INSTALLATION OF SPEEDOMETER CABLE**

Insert the cable until its stopper properly fits to the speedometer groove.

Caution

Poor installation of the cable may cause a fluctuating meter pointer, or noise and a damaged harness inside the instrument panel.

DISASSEMBLY AND REASSEMBLY

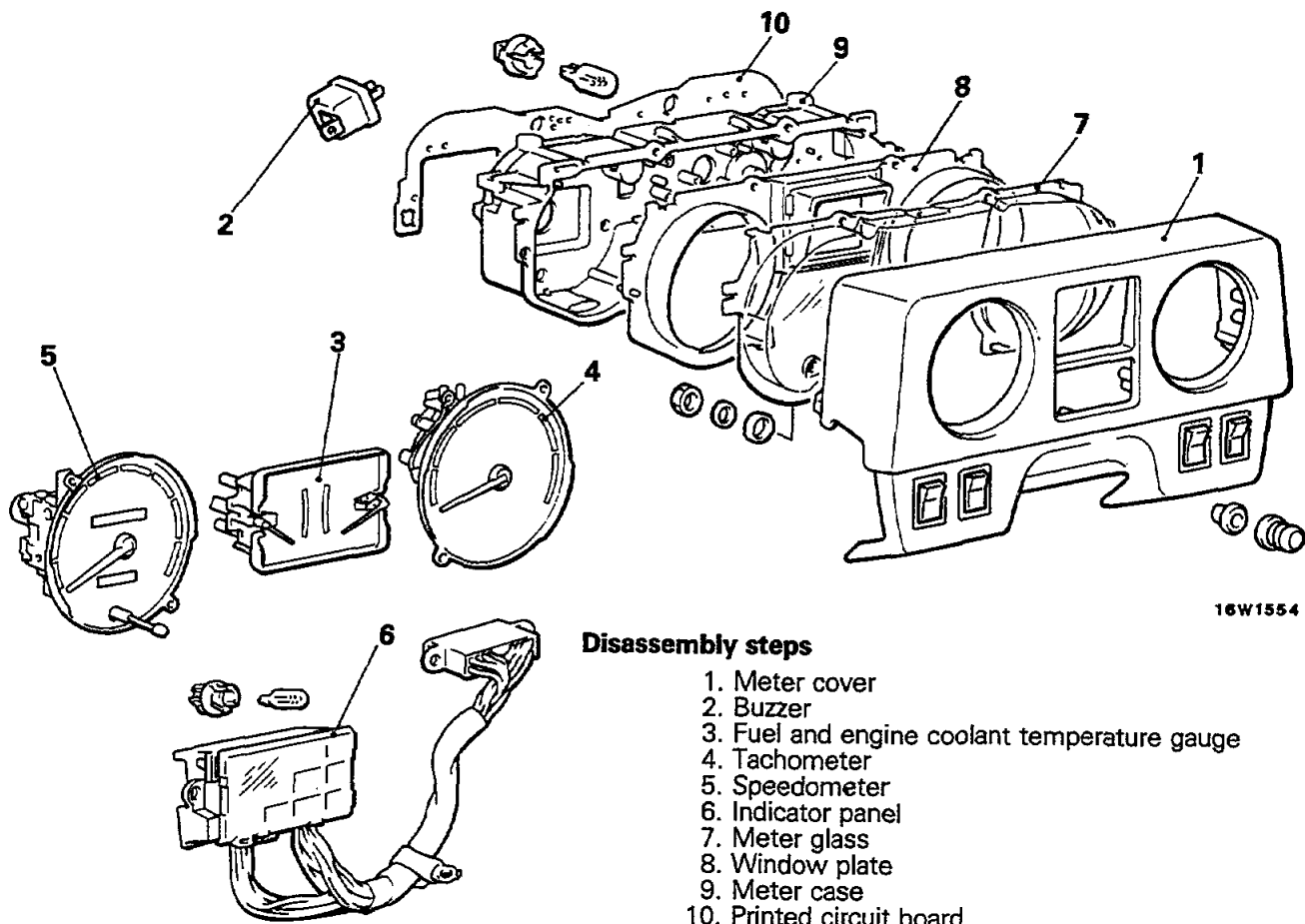

16W1554

Disassembly steps

1. Meter cover
2. Buzzer
3. Fuel and engine coolant temperature gauge
4. Tachometer
5. Speedometer
6. Indicator panel
7. Meter glass
8. Window plate
9. Meter case
10. Printed circuit board

NOTE

Reverse the disassembly procedures to reassemble.

3-METER UNIT

REMOVAL AND INSTALLATION

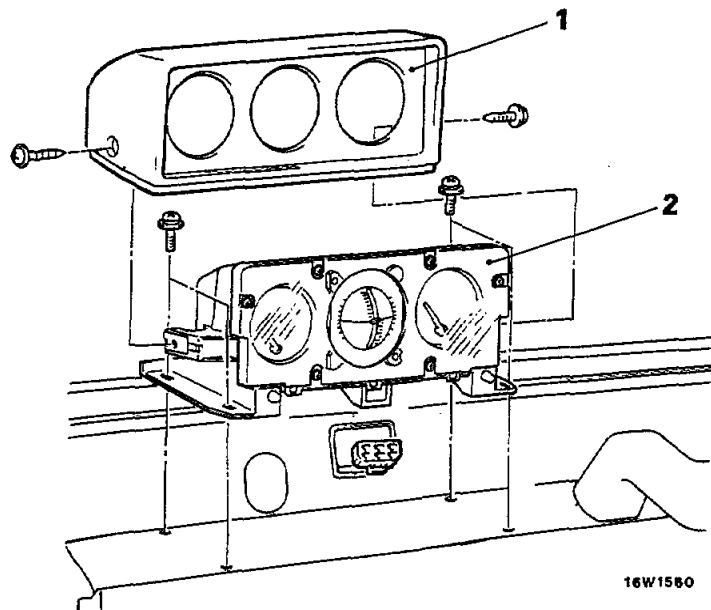

Removal steps

1. Meter pad
2. Gauge assembly

NOTE

Reverse the removal procedures to reinstall.

16W1560

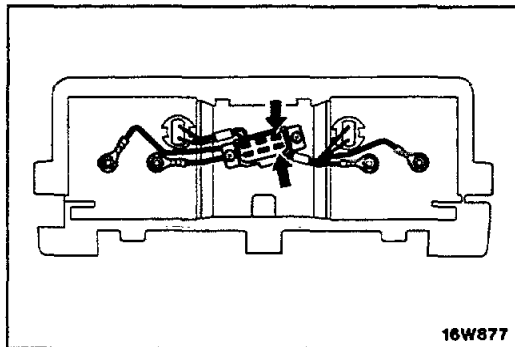
**INSPECTION****OIL PRESSURE GAUGE**

Measure the resistance value between the terminals with an ohmmeter.

Standard value: Approx. 50 Ω

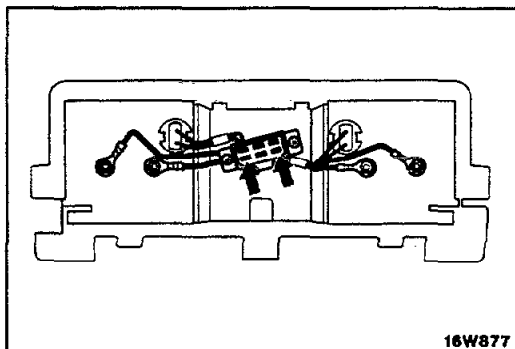
**VOLTAGE METER**

Measure the resistance value between the terminals with an ohmmeter.

Standard value: 380–460 Ω

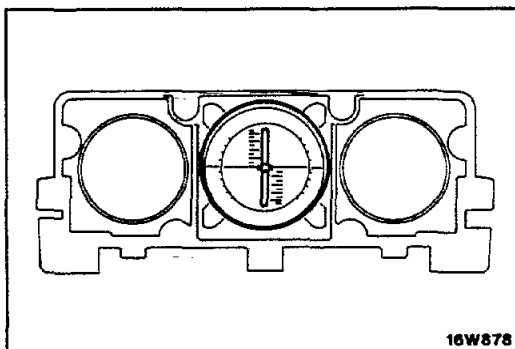
**INCLINOMETER**

- (1) Check to be sure that operation is smooth when the inclinometer is tilted up/down and to the left and right.
- (2) The inclinometer can be considered to be in good condition if the pointer indicates the spherical dial horizontal center line when the meter case is placed on a level surface.

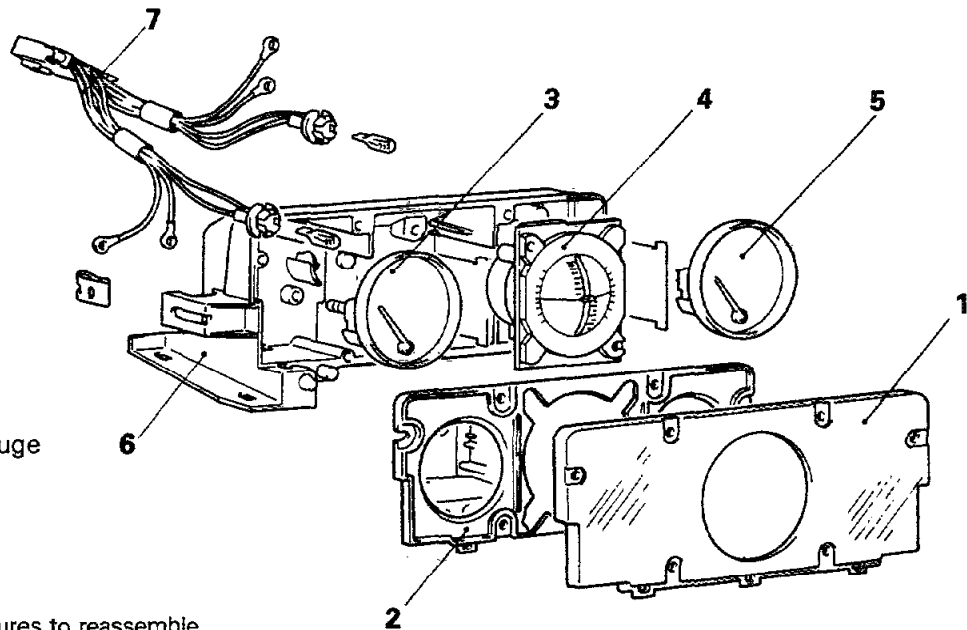





DISASSEMBLY AND REASSEMBLY**Disassembly steps**

1. Meter glass
2. Window plate
3. Oil pressure gauge
4. Inclinometer
5. Voltage meter
6. Meter case
7. Meter harness

NOTE
Reverse the disassembly procedures to reassemble.

INDICATORS AND WARNING LIGHTS

N08HKAO

Symbol		Operation
	Turn signal indicator	This indicator flashes, as do the same side of turn-signal light flashes. If the turn-signal light is burnt out, the blinking of indicator slows down. This indicator is common with hazard light.
	High beam indicator	This indicator illuminates when the headlights are on high beam.
	Door-ajar warning light	This warning light comes on when the door is either open or not completely closed.
	Fasten seat belt indicator	This indicator goes on for four to eight seconds when the ignition key is in "ON" position, even if the driver has fastened his seat belt.
BRAKE	Brake warning light	This warning light comes on when the ignition key is in "ON" position, and goes off after the engine has started. This warning light comes on when the parking brake is applied or brake fluid level falls less than the specific level.
	Charging warning light	This warning light comes on when the ignition key is in "ON" position, and goes off after the engine has started. This warning light comes on when the drive belt breaks or the trouble occurs in the charging system.
OD OFF 68R0133	Overdrive indicator	This indicator will illuminates when the overdrive control switch is switched to the "OFF" position.
A/T TEMP 68W068	A/T fluid temperature warning light	This A/T fluid temperature warning light comes on when automatic transmission fluid temperature becomes abnormally high.
WHEEL LOCK 68W080	Free-wheeling hub indicator	This indicator comes on when the automatic free-wheeling hubs are locked.
	4WD indicator	This indicator will light up when the transfer case shift lever is shifted to the four wheel driving position (either the "4H" or the "4L" position) and the ignition key is in the "ON" position.
MAINT REQD	Maintenance required warning light	This light comes on when the ignition key is in "ON" position, and goes off after the engine has started. (Lights up after every 50,000 miles, 80,000 miles, 100,000 miles and 120,000 miles travelled.)
CHECK ENGINE	Engine warning light	This light illuminates when the ignition key is turned to the "ON" position, but should go out in a few seconds. If the light illuminates while the vehicle is moving, there is a malfunction of a component related to exhaust gases.

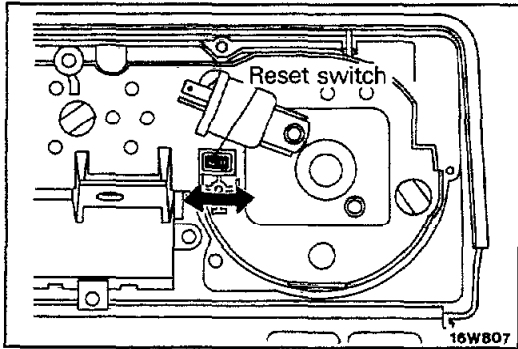

MAINTENANCE REQUIRED SYSTEM

RESET SWITCH

After checking is completed, use the reset switch (located at the rear of the combination meter) to switch OFF the warning light.

Note that the warning lights bulb should be removed after the 120,000 mileage.

NOTE

If the speedometer is to be replaced, set the new odometer to the same reading as the odometer being removed.